

MORE POWER FOR THE DOLLAR

Price vs Value
A Technical Guide

NAVSO P-3641A
(Replaces NAVMAT P-4855-1A)
October 1999

Office of the Assistant Secretary
of the Navy (RD&A)
Acquisition and Business Management



The focus of the ASN(RD&A) strategic plan is to reduce total ownership costs of our systems, supplies and services. We can achieve this goal by applying modern business practices and relying on commercial vendors to take advantage of new or emerging technologies and advancements to improve system performance while reducing cost. We believe that sharing information with industry and communicating with our stakeholders will enable us to achieve this goal.

This guide represents an initiative to improve power system management within the Department of the Navy. Developed by senior Navy professionals and the power system industry, this guide provides a useful and substantive reference for a hierarchy of information pertaining to all aspects of power supply management—Program Management, Systems Engineering, Low Voltage DC and High Voltage DC Power Supplies, and AC Power Supplies. I encourage everyone to become familiar with this guide and to apply the concepts and techniques presented to meet our power supply objectives.



G. H. Jenkins, Jr.
Rear Admiral, SC US Navy
Deputy for Acquisition &
Business Management

TABLE OF CONTENTS

PREFACE	iii
TABLE OF CONTENTS	v
INTRODUCTION	ix
ACKNOWLEDGEMENTS	xi
Section 1 Program Management	1
1.0 OBJECTIVE	1
1.1 COTS/NDI, MODIFIED COTS/NDI, AND CUSTOM POWER SUPPLIES	2
1.1.1 COTS/NDI.....	2
1.1.2 Modified COTS/NDI.....	2
1.1.3 Custom	3
1.2 POWER SYSTEM DEVELOPMENT.....	3
1.2.1 Top-Level System Requirements and Specification Development.....	4
1.2.2 Trade Studies.....	6
1.2.3 Modeling and Simulation.....	8
1.2.4 Design Reviews.....	8
1.2.5 Power System Integration and Test.....	9
1.2.6 System Design and Impact on Power System Components	9
1.3 POWER SUPPLY PERFORMANCE SPECIFICATION	9
1.4 MARKET RESEARCH	10
1.4.1 Power Supply Acquisition/Development Time.....	11
1.4.2 Power Supply Selection/Development Man-Hours	11
1.5 POWER SUPPLY TRADE-OFFs/ SELECTION	13
1.5.1 Total Ownership Cost.....	13
1.5.2 Power Supply Reliability	14
1.6 TEAMING	17
1.7 RISK MANAGEMENT	18
1.8 WATCH OUT FORs.....	18
Section 2 Power System Considerations	21
2.0 OBJECTIVE	21
2.1 POWER SYSTEM ARCHITECTURE.....	22
2.2 PRIME POWER SOURCE	26
2.3 ELECTROMAGNETIC COMPATIBILITY	27
2.4 MONITORING AND CONTROL	28
2.5 ENVIRONMENTAL ISSUES	28
2.6 SPECIFYING LOAD POWER	29
2.7 PROTECTION.....	29

2.8 TESTING.....	30
Section 3 Low Voltage Power Supplies.....	31
3.0 OBJECTIVE.....	31
3.1 DESIGN GUIDELINES	32
3.1.1 <i>Circuit Design Topology</i>	32
3.1.2 <i>Component Selection</i>	32
3.1.3 <i>Reliability</i>	34
3.2 DESIGN ANALYSES/VERIFICATION.....	37
3.2.1 <i>Analyses</i>	37
3.2.2 <i>Prototype Evaluation</i>	38
3.2.3 <i>Design Reviews</i>	38
3.2.4 <i>Design Qualification Testing</i>	40
3.3 MANUFACTURING CONSIDERATIONS	41
3.3.1 <i>Manufacturing Process Considerations</i>	41
3.3.2 <i>Environmental Stress Screening</i>	44
3.3.3 <i>Acceptance Testing</i>	47
3.4 STANDARD PRACTICES	48
Section 4 High Voltage Power Supplies.....	51
4.0 OBJECTIVE.....	51
4.1 DESIGN GUIDELINES	52
4.1.1 <i>Corona</i>	52
4.1.2 <i>Component Considerations</i>	53
4.1.3 <i>Other Design Considerations</i>	54
4.2 DESIGN ANALYSES/VERIFICATION.....	57
4.2.1 <i>Reference Performance Data</i>	58
4.2.2 <i>Components</i>	58
4.2.3 <i>High Voltage Power Supply Tests</i>	58
4.2.4 <i>Design Review Checklist</i>	61
4.3 MANUFACTURING CONSIDERATIONS	61
4.3.1 <i>Dedicated Facilities</i>	61
4.3.2 <i>Receiving Test and Inspection</i>	62
4.3.3 <i>Detailed Procedures</i>	63
4.3.4 <i>Environmental Stress Screening</i>	64
4.3.5 <i>Personnel Training</i>	64
4.4 STANDARD PRACTICES	64
4.4.1 <i>Insulation Systems/Encapsulation</i>	64
4.4.2 <i>Circuit Partitioning</i>	67
4.4.3 <i>Shorted or Open Outputs</i>	67
Section 5 AC Output Power Supplies - Inverters, Frequency Changers and Uninterruptible Power Supplies.....	69
5.0 OBJECTIVE.....	69
5.1 DESIGN GUIDELINES	70
5.1.1 <i>AC Output Considerations</i>	70
5.1.2 <i>AC Bus Frequencies</i>	71

5.2 DESIGN ANALYSES/VERIFICATION.....	71
5.3 MANUFACTURING CONSIDERATIONS	71
5.4 STANDARD PRACTICES	71
5.4.1 <i>Common Practice for Inverters and Frequency Changers</i>	72
5.4.2 <i>Common Practice for UPS</i>	74
APPENDIX A Sample Power Supply Performance Specification Checklist.....	A-1
DC POWER SUPPLY PERFORMANCE SPECIFICATION	A-3
SUPPLEMENTAL PERFORMANCE SPECIFICATION CHECKLIST FOR AC OUTPUT POWER SUPPLIES	A-10
APPENDIX B Design Review Checklists for Power Systems and Power Supplies	B-1
SAMPLE DESIGN REVIEW CHECKLIST FOR POWER SYSTEMS	B-3
SAMPLE DESIGN REVIEW CHECKLIST FOR POWER SUPPLIES	B-7
APPENDIX C Modified COTS/NDI and Custom Power Supply Supplier Evaluation	C-1
APPENDIX D Platform Power Characteristics	C-1
<i>Shipboard</i>	<i>D-3</i>
<i>Aircraft</i>	<i>D-5</i>
<i>Trade-Offs</i>	<i>D-6</i>
APPENDIX E Parts Derating Tables	E-1
APPENDIX F Glossary	F-1

INTRODUCTION

In 1982, the Navy published its first power supply guideline document entitled “Navy Power Supply Reliability,” NAVMAT P-4855-1. That document primarily addressed reliability concerns with low voltage power supplies. In 1989, the Navy published the first update to the original document by adding a section on high voltage design and manufacturing guidelines. This 1999 publication replaces NAVMAT P-4855-1A and is focused on specifying, selecting and fielding power supplies in an acquisition reform and commercial practices environment.

As a useful reference tool, this guide will assist Navy managers, weapon system contractors and power supply vendors in identifying and understanding the alternatives and options available in selecting best power supply value. Particular attention has been given to emphasizing best value for each of three categories of power supplies: Commercial-Off-The-Shelf/Non-Developmental Items (COTS/NDI), Modified COTS/NDI, and Custom. In addition, a technique is provided for measuring Total Ownership Costs.

This document is divided into five sections. Section 1 is written for program managers and provides basic but critical points to consider in acquiring power supplies. Section 2 addresses Power System Considerations and their impact on power supply design, selection, and application. Sections 3, 4 and 5 provide guidance in the design, test and manufacturing of Low Voltage DC Power Supplies, High Voltage DC Power Supplies, and AC Power Supplies, i.e., Inverters, Frequency Changers, and Uninterruptible Power Supplies.

The appendices contain a variety of checklists, platform power characteristics, derating criteria and a glossary of specialized terms.

ACKNOWLEDGEMENTS

The Office of the Assistant Secretary of the Navy (Research, Development and Acquisition) Acquisition and Business Management wishes to acknowledge the team of experts responsible for developing this document and to express appreciation for their extensive contributions.

Program Sponsors

RADM G. H. Jenkins Jr.
Ed Callaway

Director, ASN(RD&A)ABM
Director, ASN(RD&A)ABM-PR

Executive Committee

Don Hornbeck, Chairman
Eric Grothues, Co-chairman
Doug Patterson
Mick Finn
Tosh Oishi
Ed Smith

RANTEC Power Systems/Beck Associates
ASN(RD&A)ABM
Consultant, PATCON
EG&G Technical Services, Inc.
IIT Research Institute
EG&G Technical Services, Inc.

Technical Contributors

Dick Blake
John Carroll
Patrick Casey
Don Hornbeck
Rick Lapp
Dwight Monteith
Tosh Oishi
Dave Prestel
Alex Rokhvarg
Bill Singleton
Tim Spotts
Toby Stecklein
Carlos Urdiales
Evan Vogel
Jack Wright

Transistor Devices, Inc.
Transistor Devices, Inc.
Southwest Research Institute
RANTEC/Beck Associates
American Avionic Technologies Corp
DOM Engineering Services, Inc.
IIT Research Institute
Northrop Grumman
Transistor Devices, Inc.
Lockheed Martin Corporation
Transistor Devices, Inc.
Southwest Research Institute
Southwest Research Institute
Transistor Devices, Inc.
Berkshire Associates

The Navy and contributing committee members dedicate this Power Supply guide to the late Willis J. Willoughby, Jr., who was the Director of Product Integrity, Office of the Assistant Secretary of the Navy (Research, Development and Acquisition), prior to his retirement in 1995. The spirit of his foresight, leadership and commitment to technical discipline and power supply excellence were guiding factors in the development of this document.

Section 1

Program Management

1.0 OBJECTIVE

The operational effectiveness of most military electronic/avionics weapon systems is dependent to a significant degree upon the effectiveness and suitability of the power supply selected to deliver the required power to the host weapon system when needed. It is vitally important that program managers understand that, at the heart of their weapon systems, power supplies are a complex combination of multiple design considerations dedicated to the unique requirements of the system they serve. As such, this section is intended to provide program managers greater insight into the acquisition and technical risk issues, with the emphasis on technical risk, affecting their selection of the right power supply to meet their needs. This higher level insight will reduce not only the potential for power supply failures and their impact on more serious mission failures, but also the Total Ownership Cost (TOC) of the weapon system itself.

This section provides fundamental information to enable the program manager to provide the necessary leadership and direction. Included in these fundamentals is a compilation of information, not normally found in the public domain, which was collected during the development of this document from the invaluable experiences of our committee members representing the power supply industry. This section covers the following topics:

- 1.1 COTS/NDI, Modified COTS/NDI, and Custom Power Supplies
- 1.2 Power System Development
- 1.3 Performance Specification
- 1.4 Market Research
- 1.5 Trade-Offs/Selection
- 1.6 Teaming
- 1.7 Risk Management
- 1.8 Watch Out For...

1.1 COTS/NDI, MODIFIED COTS/NDI, and CUSTOM POWER SUPPLIES

Military power supplies can be divided into three categories, Commercial-Off-The-Shelf/Non-Developmental-Items (COTS/NDI), Modified COTS/NDI, and Custom. The choice of the particular category should be directly related to the intended power system application and environment. Program risks often originate from early management decisions regarding the performance specification requirements and trade-offs leading to the procurement or development of any one of the power supply categories.

1.1.1 COTS/NDI

COTS power supplies are basically those previously developed for non-military applications, such as those used in telecommunications equipment or air traffic control systems. COTS power supplies generally perform to their published specification, which usually applies to a benign environment. However, their performance would be detrimentally affected when subjected to harsh environmental conditions, such as non-sheltered, extended temperature range of -55 to +85 degrees C or greater, and shock and vibration. If the COTS power supply requires protection from severe system environments, it may be placed in a protective enclosure. COTS power supply documentation should be obtained to ensure that the power supply will be compliant with the intended application and environment. If such documentation is not available, consideration should be given to additional testing.

NDI power supplies are basically those previously developed exclusively for government use which can include the harsh environmental conditions associated with DoD military applications. An NDI previously developed for a specific military application may not meet other proposed application and environmental conditions without design changes or environmental protection, a situation that is also true for COTS previously developed for commercial use.

1.1.2 Modified COTS/NDI

Modified COTS/NDI power supplies are those previously developed, but require modifications to accommodate a particular application. Examples of such modifications include an additional output voltage(s), a change to the existing output voltage(s) or current capability, a change to the Built-In-Test (BIT) requirements, or changes to accommodate environmental capability. The availability of a modified commercial power supply depends on the extent of modifications required. As with the COTS power supply, the Modified COTS/NDI power supply should be subjected to and successfully demonstrate compliance with the power system application and environment.

1.1.3 Custom

This category of power supplies requires a full development program with the requirements tailored to the specific power system. The power supply may have unique capabilities, such as digital input/output control, reporting of specific functions, TEMPEST management and/or nuclear circumvention.

1.2 POWER SYSTEM DEVELOPMENT

The following are addressed for successful development of a power system:

- 1.2.1 Top-Level System Requirements and Specification Development
- 1.2.2 Trade Studies
- 1.2.3 Modeling and Simulation
- 1.2.4 Design Reviews
- 1.2.5 Integration and Test
- 1.2.6 System Design and Impact on Components

The development of power supplies for power systems has often been performed improperly. Inadequate specification of power system requirements and integration can result in operational incompatibility between equipment and subsystems and cause premature power supply failures. Failures can be induced electrically, mechanically, and/or thermally by operating conditions that are defined incorrectly or insufficiently. Power supply failures can affect system readiness and program costs associated with such issues as spares, repairs, reports, redesign (if necessary), and system checkout.

Power supplies are expected to convert variable transient-laden external power sources into regulated, noise-free usable power, while simultaneously isolating the power source and distribution system from load generated noise, distortion and transients. Power supplies are traditionally allocated the lowest priority and the smallest possible physical volume. Hence, power supplies are often improperly specified for their operating environment and overstressed. The key to achieving system performance and reliability is proper integration of power supplies into the weapon system.

Overall power system performance risk, supportability and TOC can be managed with a thorough power system design process from which power supply performance specifications can be developed. This process must be repeated for upgrades and other forms of power system modifications. The following paragraphs describe elements of the system engineering process in a sequential fashion, leading to definition of the power supply interface requirements and power supply performance specification (see Appendix A, Sample Power Supply Performance Specification Checklist).

SECTION 1

1.2.1 Top-Level System Requirements and Specification Development

A complete review of the top-level requirements is necessary to understand the overall requirements for the weapon system and the primary functionality of the power system. The weapon system functional requirements are the basis for performing trade-off studies between various candidate power system architectures.

After the individual requirements are defined, they must be partitioned to each component within the power system. This partitioning forms the basis for specification development for these components. Interfaces between each component must be defined to ensure interconnectivity and interoperability between the individual components and overall system functionality. The interface specification precludes, to a high degree, improper/incompatible operation and provides the basis for development of the power supply performance specification.

The following eight topics must be addressed for successful power system design and integration:

- **Power Source Distribution and Protection** - Determine the prime power source impedance and select the distribution protection devices capable of interrupting the applicable worst case short circuit current. Turn-on-off sequencing of the individual loads can be accomplished via the distribution protection device holding coils. If the power system is vulnerable to a lightning strike or a nuclear imposed Electro Magnetic Pulse, surge arrestors should be considered at the external prime power interface. Remote monitoring and control should be addressed as applicable. In a three phase system, loss of phase or improper phase rotation should inhibit the use of circuit protective devices. A utility outlet should be provided at the power distribution center for maintenance purposes.
- **Power Supply to Source Interface** - Define (1) the expected characteristics and quality of the power source from which the power supply must operate, and (2) the constraints on the load presented by the power supply to the power source.
- **Power Supply to Load Interface** - Define (1) the expected characteristics and quality of the power supply's output, and (2) the characteristics of the load presented to the power supply. Tolerances and limits must be established realistically to maximize the number of potentially usable power supplies.
- **Remote Control and Monitor Interface** - Define the power supply functions to be remotely controlled. To maximize the possibility of using a COTS/NDI power supply without modifications, the specific details of the control signal format should be left open. Maintaining the flexibility to adapt the weapon system's interface circuitry to what the COTS/NDI power supply provides will maximize the number of candidate products. Define the measured data and status items to be reported by the power supply. To maximize the possibility of using a COTS/NDI power supply without modifications, the specific details of the signal formats should also be left open. Note that this approach may add cost to other parts of the system to keep the original power supply procurement

cost low. Program managers should review this interface carefully to ensure that cost is not being moved from one place to another.

The interfaces discussed above are shown in Figure 1.2-1, System Interfaces.

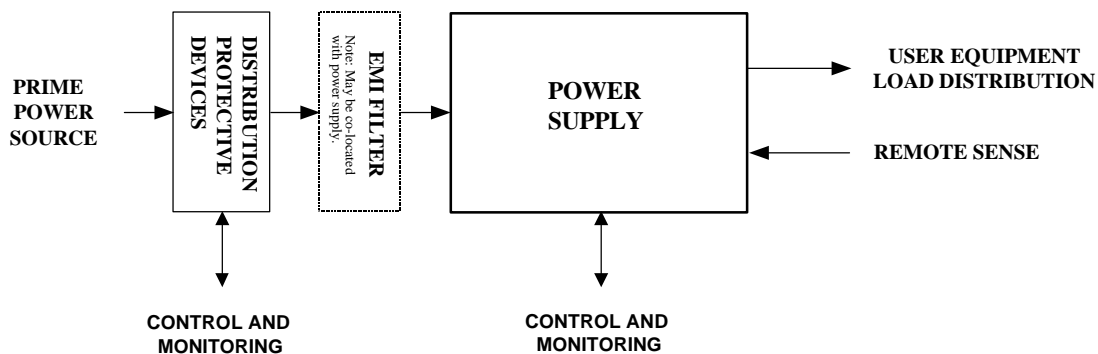

Figure 1.2-1. System Interfaces

Once a candidate supply has been selected, the interface must be defined in terms of signal levels and formats, data dictionaries, and other required parameters as follows:

- **Operating and Storage Environment** - The environment to which the power supply is to be exposed must be defined. The power system requirements should be derived from the weapon system mission profile. Since COTS power supplies normally are not designed to work in a military environment, it may be necessary to consider means of ameliorating the environment to enable their cost-effective use. Examples include use of compliant shock mounts and sealed or ruggedized power supply enclosures. The cost of providing a ruggedized mounting may well be less than that of redesigning the power supply to pass qualification tests.
- **EMI/EMC and Acoustic Noise Requirements** - Modern, high density power supplies employ switching circuit topologies that may both generate and be susceptible to noise. The use of a switching topology and the presence of cooling fans may also become sources of air-borne and structure-borne acoustic noise. Define the acceptable levels of radiated and conducted electromagnetic and acoustic noise that the supply may generate and the electromagnetic noise environment in which the power supply must function. Electromagnetic limits are typically specified in terms of MIL-STD-461, while acoustic noise limits are defined by MIL-STD-740. Care must be taken to avoid over-constraining allowable noise levels coming from the power supply, as the cost of meeting the requirements may be substantial, in terms of both dollars and the amount of additional hardware required. The source of weapon system noise to which the power supply is sensitive should be explicitly identified. The use of external shielding or filtering should be considered if it allows use of an otherwise acceptable COTS/NDI power supply. If a filter is added, the impact on operational stability and TOC should be understood.

SECTION 1

- **Allocated Weight and Volume Requirements** - Define the physical envelope in which the power supply must be contained and the allocated weight constraints. The envelope drawing should identify the required mounting surface and orientation, direction of available air flow and exhaust, location of cable interconnections, and the nature and type of all immediately adjacent components and subassemblies. Ideally, details of the specific mounting interface should be left undefined to permit adaptation to the power supply that is finally chosen.
- **System Verification Tests** - Define the system analyses and tests, by which the design and performance suitability of a candidate power supply will be verified. Successful system verification and prompt resolution of issues during testing require the support and cooperation of both the prime contractor and the power supply vendor.

In defining power supply requirements, especially for COTS/NDI, it is important that:

- The prime contractor clearly defines to the power supply vendor(s) what is really needed from the power supply and provides a clear description of the mission functional and environmental profiles to which the power supply is to be exposed.
- The power supply vendor can identify which standard products (if any) are suitable to the application, or can identify the modifications to a standard product that are required for the application. If neither of these options can be accomplished, a custom design can be identified.
- The effect on TOC, including recurring production costs, should be assessed.

Development of detailed specifications for each equipment or software must include necessary requirements, e.g., acceptance and system-level integration tests. These specifications guide the development of new hardware, the procurement of COTS/NDI equipment, and/or the modification of power supplies to meet the system level requirements.

1.2.2 Trade Studies

Trade studies are performed to consider options for designing the power system to meet the top-level requirements and to compare the attributes and cost of each option. Based on the trade-off analyses, a power system architecture emerges which forms the basis for defining the specific requirements of the power equipment. Requirements can still be assigned to different components of the power system. For example, locating the EMI filter in the front end of a power supply versus in a separate equipment, or managing the inrush current at a system level versus in the front end of the power supply, are just two of the considerations. It is often cost effective to utilize COTS/NDI high density power modules as well as AC power supplies in combination with power-conditioning equipment to satisfy the power system requirements. As the options are considered, trade-offs are made and the requirements for each component within the power system are defined.

Trade studies aimed at defining power system architecture can be illustrated by two examples. One relates to high density DC power requirements and the other to AC output power supplies. These two examples are discussed below.

- **Developing Power Systems Utilizing High Density DC/DC Modules** - Reliable power supply designs with high output power density are generally achievable using standard switching power supply components and topologies widely available in industry today. To minimize cost and the time to develop a power system, existing high density DC/DC modules are often incorporated into the design. High density modules are available that provide electromagnetic compatibility, thermal management, prime power rectification, input voltage multiplication, power factor correction and non-isolated and isolated user output voltage conversion.

The design approach to incorporate these modules, however, is not as simple as may be indicated by many of the manufacturers' literature. The advertised power densities of DC/DC converter modules should not be considered as the total allotted power system packaging volume. It is not uncommon to see advertised power densities in excess of 70 watts/cubic inch. However, a review of the manufacturer's data would reveal that the advertised power density is only accomplished at moderately low temperatures and at a specific input and output voltage. Moreover, these power density figures are often a calculation of only a DC/DC converter module without other components that must be added in order to meet the complete power system specification. These added components may include:

1. EMI filtering,
2. input AC/DC rectification with filtering/bulk input hold-up capacitance,
3. supplemental output filtering,
4. auxiliary function circuitry (sequencing, synchronization, BIT, on/off control etc.),
5. cooling, and
6. physical packaging.

Selection of DC/DC converter modules should take into consideration the manufacturer's reputation in supplying reliable products for applications consistent with weapon system requirements. Once viable vendors have been identified, a detailed examination should be conducted for each electrical and physical parameter applicable to the power system requirements. A power system consists not only of DC/DC high density converters, but often includes EMC management, thermal management, prime power conditioning/protection, monitoring and control as well as common mode and differential filtering. When all of the above is taken into consideration, it is not uncommon to achieve an overall power system power density of between 10 and 15 watts per cubic inch, well below the advertised 70 watts/cubic inch. Detail considerations are discussed in Section 3 of this document.

- **Developing Power Systems Utilizing AC Power Supplies (DC-AC Inverters, Frequency Changers, Voltage Conditioners, and AC UPS Systems)**
The military platform power DC or 400 Hz AC, is often not compatible with COTS equipment. However, regulated AC power supplies can electronically convert the platform DC power bus into a standard AC bus that provides commercial voltages,

SECTION 1

enabling greater use of COTS/NDI equipment (computers, monitors, etc.) in the weapon system. The resulting power architecture with its universal power grid allows flexibility in supporting weapon system re-configuration without costly power supply and equipment redesign.

AC power conversion architecture should always be considered in trade studies. With power supplies often constituting less than 10% of the total system cost, it often proves cost effective to convert the platform power to a commercial-standard AC bus. The standard power allows the use of COTS end-user equipment, thus affording the opportunity to utilize standard computers, monitors, printers, and related equipment. As a result, NDI utilization is expanded to the major portion of the system.

The corollary benefit of commercial-standard AC bus utilization is system flexibility. Availability of COTS end-user equipment allows simple system re-configuration or redesign. Unlike customized end-user equipment, change of vendors or sequential system alterations will not require extensive engineering and qualification effort.

Bulk power conversion (not limited to AC only) creates a potential single-point of failure. A failure of the bulk power supply may result in total system shutdown if power is not effectively distributed. When addressing mission-critical applications, provisions for safety bypass or redundancy should also be evaluated.

1.2.3 Modeling and Simulation

System level modeling and simulation supports the allocation of requirements component by component. The performance of each component is simulated to investigate proper operation of the power system, e.g., meeting the requirements, determining compatibility among all components, and determining compatibility between each component and the power system. A thorough consideration of the interface design margins can minimize tolerance problems that may arise later in the power supply design phase or the system test and integration phase. Simulations can provide support for design review and analysis, interface characteristics, systems integration, power supply requirements, and the facilitation of system trade offs.

1.2.4 Design Reviews

An important part of the systems engineering process is the periodic review of power system development. These reviews are necessary to verify power supply compliance with the power system interface requirements (see Appendix B, Design Review Checklist for Power Systems and Power Supplies).

1.2.5 Power System Integration and Test

System integration and testing are performed to verify that all components within the power system and the related interfaces are compatible. This testing should include all of the operational requirements and be based on the most stressful operating conditions.

1.2.6 System Design and Impact on Power System Components

Power system interfaces that are poorly defined and tested often result in unacceptable system performance and reduced MTBF. Even when a system functions within performance parameters, there is still a reasonable amount of risk that reliability will suffer since power system components may be stressed to levels far above those for which they were designed. Lack of coordination among multiple users of a single power source adds further stress and increases the risk of system instability.

1.3 POWER SUPPLY PERFORMANCE SPECIFICATION

Since current DoD policy emphasizes greater use of performance and commercial specifications and standards, Navy programs are able to gain greater access to commercial, state-of-the-art technology. Performance specifications translate operational requirements into more technical language that tells the power supply manufacturer: 1) what is considered an acceptable power supply, and 2) how it will be determined whether the power supply is acceptable. It should be clearly understood that problems may arise if specifications tell how to make the product. This section and Appendix A are intended to cover several basic considerations for program managers pertaining to the preparation of a power supply performance specification. The Appendix A checklist contains details for the following major headings:

1. Input Parameters
2. Output Voltages(s)
3. Output Current(s)
4. Regulation
5. Periodic and Random Deviation
6. Transient Response
7. Temperature
8. Stability
9. Environmental Conditions (Operating)
10. Electromagnetic Interference
11. Reliability
12. Maintainability
13. Built-in-Test
14. Control
15. Protective Devices
16. Local Status Indication
17. Electrical Interface
18. Physical Requirements
19. Prohibited Materials
20. Cooling Requirements
21. Qualification Tests
22. Production Acceptance Tests

SECTION 1

In addition to the general guidance cited above, AC output power supplies (Inverters, Frequency Changers, UPSs) are subject to unique requirements that should be addressed in the performance specification. These unique requirements are addressed in Section 5 of this document. To aid in the development of a performance specification, Appendix A also includes a sample Supplemental Performance Specification Checklist for DC-AC Inverters, Frequency Changers, and UPSs.

Features and tolerances should be specified only to the levels needed by the system to achieve acceptable system performance. If a power supply fails to meet a non-critical requirement, and is otherwise acceptable, sensitivity analyses should be used to determine the impact of performance trade offs.

DoD Performance Specification Guide, SD-15, should also be reviewed for additional information applicable to all types of material, including power supplies.

1.4 MARKET RESEARCH

Market research is an iterative process for gathering data on suppliers' capabilities, the characteristics of their products, and their standard business practices. This research is necessary to obtain information on candidate COTS/NDI products that may meet the draft power supply performance specification and support requirements (see Appendix A). When performed early in the Concept Exploration phase, market research can also help in decisions regarding the power system design and support concept to be implemented.

The market research data is analyzed to determine with confidence whether:

- the program's requirements can be met by available COTS/NDI power supplies,
- the suppliers are able to modify their COTS/NDI power supplies, or
- a custom development effort must be conducted.

The potential suppliers are assessed through various means, such as manufacturing surveys/evaluations (see Appendix C, Modified COTS/NDI and Custom Power Supply Supplier Evaluation), past performance, design and test data, cost information. Should the information to conduct such assessments not be available or inadequate to determine whether or not the COTS/NDI products can meet the expected weapon system application and environmental requirements, additional analyses and testing may be required. The market research data and trade study findings (see Subsection 1.5, Trade-Offs/Selection) may result in modification of the power supply performance specification and related support requirements.

The cost and schedule to modify a COTS/NDI power supply or develop a Custom power supply can vary significantly depending on the specific application requirements. The following three subsections provide insight, for comparison purposes, that may aid program managers in making the right decision regarding the category of power supply selected.

1.4.1 Power Supply Acquisition/Development Time

Power supplies for the military environment which fall into any one of the three power supply categories can also have a wide spectrum of configurations. The associated design and manufacturing effort can vary from simple to complex, with cost affected accordingly. For purpose of comparison, a rough estimate of the acquisition and development time for each power supply category is shown in Table 1.4-1.

Table 1.4-1. Power Supply Categories

Category	Description	Acquisition Time (for “production-ready” power supplies)
COTS/NDI	Use of existing COTS/NDI products	Less than 6 months
Modified COTS/NDI	Use of existing techniques or circuit functions with modifications or ruggedized/modified COTS/NDI	Less than 9 months
Custom	New development, extensive design, may require some invention	Greater than 9 months

1.4.2 Power Supply Selection/Development Man-Hours

In order to understand the cost to acquire, or develop, and integrate a power supply into the weapon system, typical personnel requirements in man-hours for each power supply category are provided in Tables 1.4-2, 1.4-3, 1.4-4a and 1.4-4b.

Table 1.4-2. Typical Prime Contractor Labor Requirements for Integrating a COTS/NDI Power Supply

	Man-Hours		Man-Hours
Systems Engineer	220	Integration and Qualification Support	120
Engineering Technician	80	Thermal Analyst	20
Mechanical Engineer-Interface/Environment	160	Interface Documentation	160
Reliability Engineer	80	Source Selection/Vendor Interface	120
		Total man-hours	960

Note 1: Subcontractor/vendor costs must be added

SECTION 1

Table 1.4-3. Typical Prime Contractor Labor Requirements for Integrating a Modified COTS/NDI Power Supply

	Man-Hours		Man-Hours
Systems Engineer	260	Vendor Interface	160
Engineering Technician	120	Thermal Analyst	80
Mechanical Engineer- Interface/Environment	240	Interface Documentation	120
Reliability Engineer	160	Source Selection	120
Components Engineer	160	Integration & Qualification Support	160
Total man-hours			1,580

Note 1: Subcontractor/vendor costs must be added

Table 1.4-4a. Typical Prime Contractor Labor Requirements for the Development of a Custom Power Supply

	Man-Hours		Man-Hours
Systems Engineer	320	Source Selection	160
Engineering Technician	160	Vendor Interface	280
Mechanical Engineer	280	Thermal Analyst	80
Reliability Engineer	240	Interface Documentation	120
Components Engineer	240	Integration & Qualification Support	200
Stability Analyst	50	Total man-hours	
			2,080

Note 1: Additional man-hours may be required on high voltage designs.

Table 1.4-4b. Typical Vendor Labor Requirements for the Development of a Custom Power Supply

	Man-Hours		Man-Hours
Electronics Engineer	1,200	Manufacturing Engineer	400
Engineering Technician	600	Drafting (full documentation)	1,200
Mechanical Engineer	450	Assembly	300
Designer	600	Quality Assurance Inspection	100
Reliability Engineer	200	Qualification Testing	500
Components Engineer	300	Special Test Equipment	200
Stability Analyst	50	Project Engineer	400
Thermal Analyst	100	Total man-hours	
			6,600

Note 1: Material costs must be added to the man-hour costs.

Note 2: Additional man-hours may be required on high voltage designs.

Custom Power Supply Development Cost as a Percent of Weapon System Cost

System contractors who both manufacture and purchase power supplies estimate the power supply development cost at 5% to 10% of the total weapon system development cost, excluding

software. The development cost is estimated based on anticipated man-hours plus material, which often includes subcontracted environmental and electromagnetic interference/compatibility (EMI/EMC) testing. The development cost must be modified upward for a state-of-the-art design. Recurring power supply cost may be estimated as 2.5 to 5 times the Bill of Material plus additional costs imposed as a result of production environmental stress screening (ESS). This ESS typically amounts to 5% to 10% of the total recurring power supply production cost.

1.5 POWER SUPPLY TRADE-OFFs/ SELECTION

Analysis of the information obtained through the market research may result in a determination that COTS/NDI power supplies will not meet the draft performance specification and support requirements, but may be acceptable through modification of either the COTS/NDI design or the requirements. Trade-offs in the decision-making process to enable use of a COTS/NDI power supply may be feasible based on changes in performance and support requirements within the allowable min/max trade space. The trade-offs affect both the power supply and user system, and could vary depending on program constraints. These trade-offs may include:

- adding additional environmental protection in the user environment,
- changes in the maintenance concept, logistics support concept, EMI filtering concept, or technology insertion, and
- adjusting requirements related to reliability, quality, performance requirements, BIT requirements, technology insertion concept, design reference mission profile, TOC, and/or other considerations. Such adjustments should not be at the expense of operational effectiveness or suitability.

1.5.1 Total Ownership Cost

Total Ownership Cost includes the initial acquisition costs, cost of spares for maintenance-repair-replacement, operating costs, plus the secondary costs of failure such as downtime, loss of revenue, functional degradation of the system/mission, and others. Value added features of the power subsystem may add value to the primary system. These features may include:

- on/off and fault protection
- current sharing
- EMI filtering
- Redundancy
- overload, overvoltage and thermal protection
- input/output power distribution
- cooling
- Modularity
- alarm/signal monitoring
- efficiency

SECTION 1

The cost of failure, as measured by downtime and/or functional degradation of the system/mission, may dwarf the initial acquisition cost. The acquisition cost of the power system is often estimated as 5% of the system cost, but 25% of the system downtime may be caused by power system or power source failure. A reliable power source and system will often yield major TOC savings.

1.5.2 Power Supply Reliability

More reliable power systems typically increase initial acquisition costs and add complexity to the power system, but often reduce the TOC of the system. Solutions that increase the size or weight of the power system may necessitate additional evaluation and trade-off analyses. Several actions can be taken to enhance the reliability of a specific system for a specific application. Such enhancements may modestly increase power supply acquisition cost with a corresponding decrease in system TOC. The following hypothetical example indicates the effect of these enhancements on reliability:

Reliability Enhancement Example

- ◆ Assume a basic power supply design with an inherent MTBF in excess of several hundred thousand hours.
- ◆ Utilizing common commercial design and manufacturing practices, this power supply may have a typical MTBF of 50,000 hours in an operating environment.
- ◆ The same basic power supply design, using the design, analysis/verification and manufacturing guidelines contained in this document (e.g., derating, HALT, and ESS) and a field feedback and corrective action system, may achieve an MTBF incrementally approaching several hundred thousand hours after several years of field experience.

Total Ownership Cost Comparisons

The Table 1.5-1 example considers the total ownership cost comparison of three power supplies, for the same application, that vary in cost and reliability. Assumptions include:

- (PS-1) is a COTS/NDI unit with lower cost commercial design and derating practices. The MTBF is 50,000 hours when the power supply is operating within 75% of its wearout time. The power supply wear-out time is 50,000 hours. The maintenance policy is to replace all power supplies in the field when they reach 37,500 hours.
- (PS-2) is a modified COTS/NDI designed using the NAVSO P-3641A design and derating guidelines and has a higher MTBF of 100,000 hours and a wear-out time of 70,000 hours. Since 75% of wearout time is greater than the system life expectancy, no preventive maintenance (replacement) is scheduled.
- (PS-3) is a custom power supply utilizing commercial components designed, tested and qualified for performance and reliability in the system environment with environmental stress screening of all production to detect and correct production or component defects before going to the field. The MTBF is 300,000 hours and the wearout time is 70,000 hours.
- The number of systems/sites to be placed in the field is 50. To assure minimum time to repair at each site, a spare will be at each site (the initial quantity of power supplies

SECTION 1

purchased will be 100). As they are used for failure replacement or wearout, they will be recycled to the factory depot for repair/refurbishment to maintain one spare per site.

- Wearout time (in hours) is the time at which certain power supply components (e.g., fan bearings, capacitors, etc) begin to fail, through normal use. Preventative maintenance policies should include replacing all power supplies in the field prior to an increase in failures due to wearout.

Table 1.5-1. Power Supply TOC Comparisons

Power Supply (PS) Performance & Purchase Data	<i>PS-1</i> <i>COTS/NDI</i>	<i>PS-2</i> <i>Modified COTS/NDI</i>	<i>PS-3</i> <i>Custom</i>
A. Initial Quantity Purchased	50 Units	50 Units	50 Units
B. # of Spare PSs Purchased	50 Units	50 Units	50 Units
C. Total Purchase Quantity (A+B)	100 Units	100 Units	100 Units
D. Power Supply Unit Price	\$1,000	\$1,500	\$2,500
E. Extended Price (@ 100 units) (C*D)	\$100,000	\$150,000	\$250,000
F. Systems Engineering & Qualification (Prime Contractor)	960 Hours	1580 Hours	2080 Hours
G. Engineering Overhead Cost (Prime Contractor)	\$150/Hour	\$150/Hour	\$150/Hour
H. Total Systems Engineering & Qualification (Prime Contractor) (F*G)	\$144,000	\$237,000	\$312,000
I. Other Nonrecurring Engineering Development Cost	\$0	\$40,000	\$75,000
J. Total Acquisition Cost (I+H+E)	\$244,000	\$427,000	\$637,000
K. System Life Expectancy	50,000 Hours	50,000 Hours	50,000 Hours
L. Power Supply MTBF	50,000 Hours	100,000 Hours	300,000 Hours
M. Average Wearout Time	50,000 Hours	70,000 Hours	70,000 Hours
N. # of Failures/System Life Expectancy (K/L)	1 Unit	0.5 Units	0.166 Units
O. Replacement Downtime (due to Wearout Planned Maintenance)	1 Hour	1 Hour	1 Hour
P. # of PS Replaced If (N<1, then 0.0, else (N*A))	50 Units	0 Units	0 Units
Q. Downtime to Detect/Fix Failure	10 Hours	10 Hours	10 Hours
R. Total System Downtime $Q*(A*N) + (P*O)$	550 Hours	250 Hours	83 Hours
S. Cost of System Downtime/Hr.	\$1000/Hour	\$1000/Hour	\$1000/Hour
T. Total Cost of System Downtime (R*S)	\$550,000	\$250,000	\$83,000
U. Total Ownership Cost (T+J)	\$794,000	\$677,000	\$720,000

SECTION 1

Calculation of TOC for comparison purposes, as was done above, may be simplified by completing the spreadsheet (Table 1.5-2). Although the example above compares three types of power supplies, this spreadsheet works equally well for other comparisons.

Table 1.5-2: Power Supply TOC Comparisons – Spreadsheet

	Power Supply (PS) Performance & Purchase Data	PS-1	PS-2	PS-3	PS-4	Quantity Type
A.	Initial Quantity Purchased					Units
B.	# of Spare PS					Units
C.	Total Purchase Quantity (A+B)					Units
D.	Power Supply Unit Price					\$
E.	Extended Unit Price (C*D)					\$
F.	Systems Engineering & Qualification (Prime Contractor)					Hours
G.	Engineering Overhead Cost (Prime Contractor)					\$
H.	Total Systems Engineering & Qual Cost (Prime Contractor) (F*G)					\$
I.	Other Nonrecurring Engineering Development Costs					\$
J.	Total Acquisition Cost (I+H+E)					\$
K.	System Life Expectancy					Hours
L.	Power Supply MTBF					Hours
M.	Average Wearout Time					Hours
N.	# of Failures/System Life Expectancy (K/L)					Units
O.	Replacement Downtime (due to Wearout Planned Maintenance)					Hours
P.	# of Power Supplies Replaced for Wearout Maintenance (If N<1, then 0.0, else (N*A))					Units
Q.	Downtime to Detect/Fix Failure					Hours
R.	Total System Downtime (Q*(A*N) + (P*O))					Hours
S.	Cost of System Downtime/Hr					\$
T.	Total Cost of System Downtime (R*S)					\$
U.	Total Ownership Cost (T+J)					\$

1.6 TEAMING

Teaming is a “win-win” relationship based upon understanding the responsibilities and capabilities of each of the partners. This relationship is especially important when the government and prime contractor’s power supply design expertise has declined with downsizing and outsourcing. To prevent the decline of this expertise requires active practice and keeping abreast of power supply related design and manufacturing state-of-the-art advancements. This is not possible on a part-time/sharing basis, and as a result, power supply technical expertise currently resides predominately at quality power supply vendors that have design capabilities.

Without early teaming between the prime contractor and power supply vendor, the power system specification requirements will often result in an inefficient power system architecture and power supply design. Power supply expertise is a required input for system level trade offs that lead to an efficient power system specification. These trade offs, including the appropriate sharing of program risks, should continue between the prime contractor and power supply vendor throughout the detail power system design leading to the development of the power supply interface requirements and specification.

The teaming arrangement should include the technical participation of the customer, prime contractor and power supply vendors at key power systems and power supply decision points/phases during the program life cycle. Feedback and corrective action is more effective when members regularly review their contribution to the team. Table 1.6-1 displays, according to phase, a suggested schedule of meetings and technical personnel who should attend.

Table 1.6-1. Team Meetings and Required Team Members by Phase

Phase	Pre/Post Proposal		Design		Production		Operations
	Face-Face	Telecon	Face-Face	Telecon	Face-Face	Telecon	Telecon
Meeting Schedule	Initial Mtg.	1 Time minimum	Initial Mtg.	Monthly	Initial Mtg.	Monthly	Monthly
Navy	PM Tech POC	PM Tech POC	PM Tech POC	Tech POC	PM Tech POC	Tech POC	Tech POC
System Contractor	PM Engineering	Engineering	All Project Members	Engineering Logistics	All Project Members	Engineering Logistics	Logistics
Power Supply Manufacturer	PM Engineering	Engineering	All Project Members	Engineering Qual/Rel Test Environmental	All Project Members	Engineering Qual/Rel Test Environmental	Engineering Qual/Rel

SECTION 1

1.7 RISK MANAGEMENT

Technical risk management has become increasingly important as a critical tool for assuring program success. Although managing risk for all aspects of a program is necessary, technical risk is perhaps the most important area of risk management because the degree to which technical processes can be controlled is a significant driver of all other program risks.

For power supply acquisition, it is critical that a risk management strategy be established as soon as possible and become an integral part of the procurement effort, irrespective of the category of power supply, i.e., COTS/NDI, Modified COTS/NDI, or Custom. All groups involved in power supply procurement, from the Navy program office to the prime contractor and suppliers, should use the same strategy. There are key steps or tools one can use to ensure technical risk is controlled during power supply development. These are detailed in the eleven chapters of NAVSO P-3686, “Top Eleven Ways to Manage Technical Risk,” available from ASN(RD&A)ABM on CD-ROM or by downloading at www.abm.rda.hq.navy.mil. These chapters are:

1. Choose an Approach
2. Assign Accountability
3. Put Risk Management in the Contract
4. Mandate Training
5. Practice Engineering Fundamentals
6. Understand COTS/NDI Applications
7. Establish Key Software Measures
8. Assess, Mitigate, Report
9. Use Independent Assessors
10. Stay Current on Risk Management Initiatives
11. Evaluate New Acquisition Policies

1.8 WATCH OUT FORs

The following is a list of cautions or “Watch Out Fors” pertaining to specific issues that could affect power system or power supply performance if overlooked.

Power Systems – Watch Out For...
<ul style="list-style-type: none">• The untailed pass-down of the system environmental requirements• Unproven COTS/NDI hardware• Hardware with limited logistics availability• COTS/NDI equipment tested only for FCC compliance• Power interface specifications that do not reflect the operating environment• An EMI specification requiring full MIL-STD-461 compliance at the power supply level• COTS/NDI metal case power supplies which are not bonded to ground• COTS/NDI power supplies not utilizing an isolation transformer for shipboard applications• Inappropriate shifting of remote control and monitor interface costs between the power supply and the power system• Overconstraining power supply noise levels - may increase cost and hardware requirements

Low Voltage Power Supplies – Watch Out For...

- Inflated power density claims of greater than 60 watts/cubic inch
- Junction temperatures above 110°C
- New and unverified circuits required to provide power supply functions
- Power supplies with claimed reliability based only on MIL-HDBK- 217 predictions
- Use of unvalidated software analysis programs
- COTS/NDI power supplies lacking qualification data
- Spares and repairs that have not been subjected to the same manufacturing, inspection, and test processes as the original equipment
- Not testing to failure

High Voltage Power Supplies – Watch Out For...

- Vendors who lack experience designing, producing, testing and screening high voltage rectifiers, capacitors and resistors
- Hand-mixing of insulation compounds
- A high voltage power section in close proximity to a low voltage area
- Thermal measurements requiring thermocouples in the high voltage field
- Components with incompatible temperature coefficients
- Validity of corona inception voltage measurement equipment
- An increase in the corona level after temperature cycling

AC Output Power Supplies – Watch Out For...

- Load incompatibility with an AC squarewave source
- High DC content on AC output which may lead to power transformer overload
- Crest Factor capability below 2.5
- Reactive Load capability and Inrush rating if powering motors or filters
- Resonance with external filters
- A UPS holdup time not specified over the full environmental range
- Excessive recharge time requirements
- Transfer time in excess of 10 milliseconds on stand-by UPS

Section 2

Power System Considerations

2.0 OBJECTIVE

This section addresses power system considerations and their impact on power supplies in sufficient detail to:

- assist managers involved in the specification, development and acquisition process, and
- provide engineers specifying, designing, and/or integrating power supplies with factors which should be considered.

Power supplies are the critical interface between the input power source (e.g., ship, aircraft or shore power) and the user equipment, and therefore must be designed to deliver the required outputs with maximum efficiency while:

- limiting the inrush turn-on current and the turn-off voltage transients,
- surviving the hostile transients and momentary power interruptions of the power source, while maintaining the integrated system requirements,
- managing Electromagnetic Compatibility (EMC),
- preventing connected load transients from affecting the power source and distribution nodes,
- limiting line current harmonics, e.g., to the constraints of the platform requirements,
- assuring stable operation, and
- providing monitoring, control and interface protection.

The system engineer, in translating weapon system requirements to a power system architecture, establishes the reliability, cost, and performance of the ensuing power supply design. He must select a power system architecture that can provide the needed load power quality, while not over-penalizing weight, reliability and cost. The power system architecture and power supply design requirements include the following:

- 2.1 Power System Architecture
- 2.2 Prime Power Source
- 2.3 Electromagnetic Compatibility

SECTION 2

- 2.4 Monitoring and Control
- 2.5 Environmental Issues
- 2.6 Specifying Load Power
- 2.7 Protection
- 2.8 Testing

2.1 POWER SYSTEM ARCHITECTURE

Power system architecture reflects the partitioning of the system power conversion, power distribution, protection and control/monitoring features. Power system architecture selection should be performed concurrently with system partitioning to meet overall weapon system requirements. Power conversion hardware includes EMI filtering, power line conditioning (rectification, power factor correction, regulation, and harmonic distortion control), and voltage conversion. Power distribution includes interconnections from the system power interface to the power conversion stages, and from the power conversion stages to the system loads.

Various power system architectures are available to meet system requirements. Three common architectures for a user system cabinet (or other enclosure) containing various electronic loads are Centralized, Decentralized and Distributed, as shown in Figures 2.1-1, 2.1-2 and 2.1-3. In addition, a representative Fault Tolerant System is shown in Figure 2.1-4.

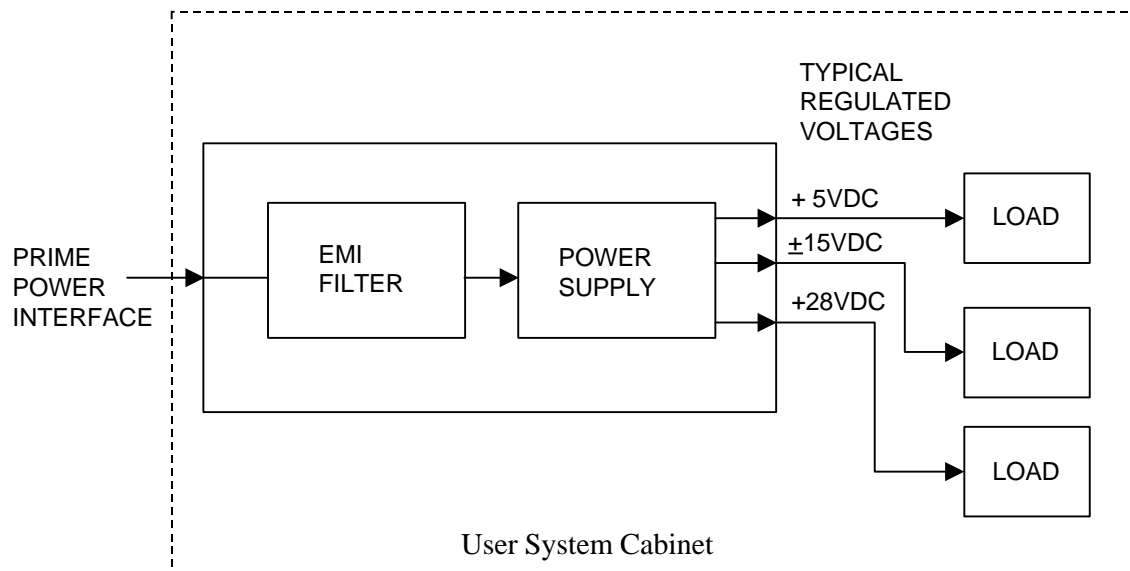

Figure 2.1-1. Centralized Power System

Figure 2.1-1 is one example of a power system architecture that shows a single power supply with multiple output voltages. Each of the voltages is distributed on a separate bus structure within the cabinet. This architecture can take forms other than that shown here, depending on the system, subsystem and component partitioning employed by the user.

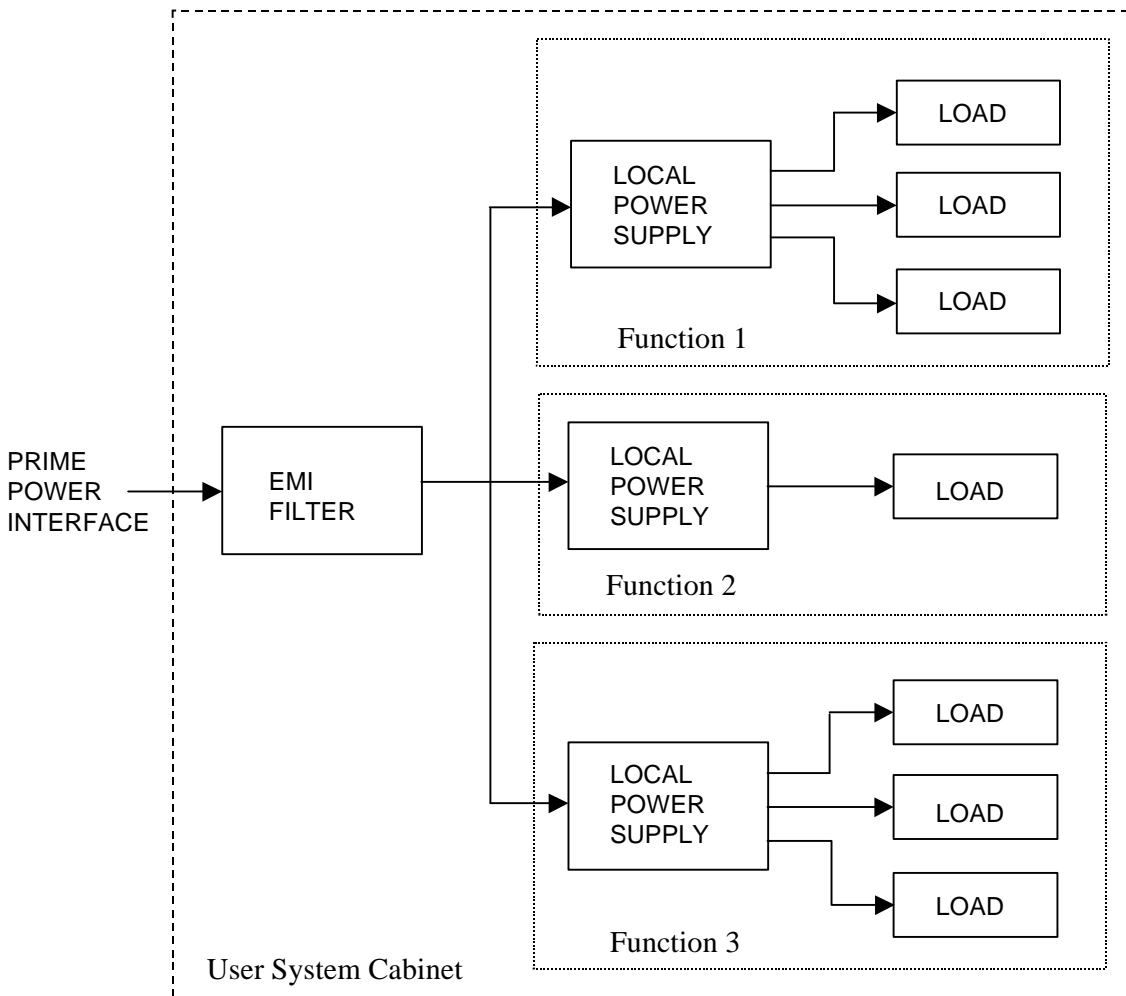

Figure 2.1-2. Decentralized Power System

Figure 2.1-2 is another example of power system architecture that may be integrated within a weapon system cabinet. Each function may have a dedicated power supply(s). An EMI filter at the cabinet level is provided. An alternative approach, resulting in greater flexibility, establishes local EMC management within each power supply (not illustrated). Other forms of this architecture can also be applied depending on user partitioning.

SECTION 2

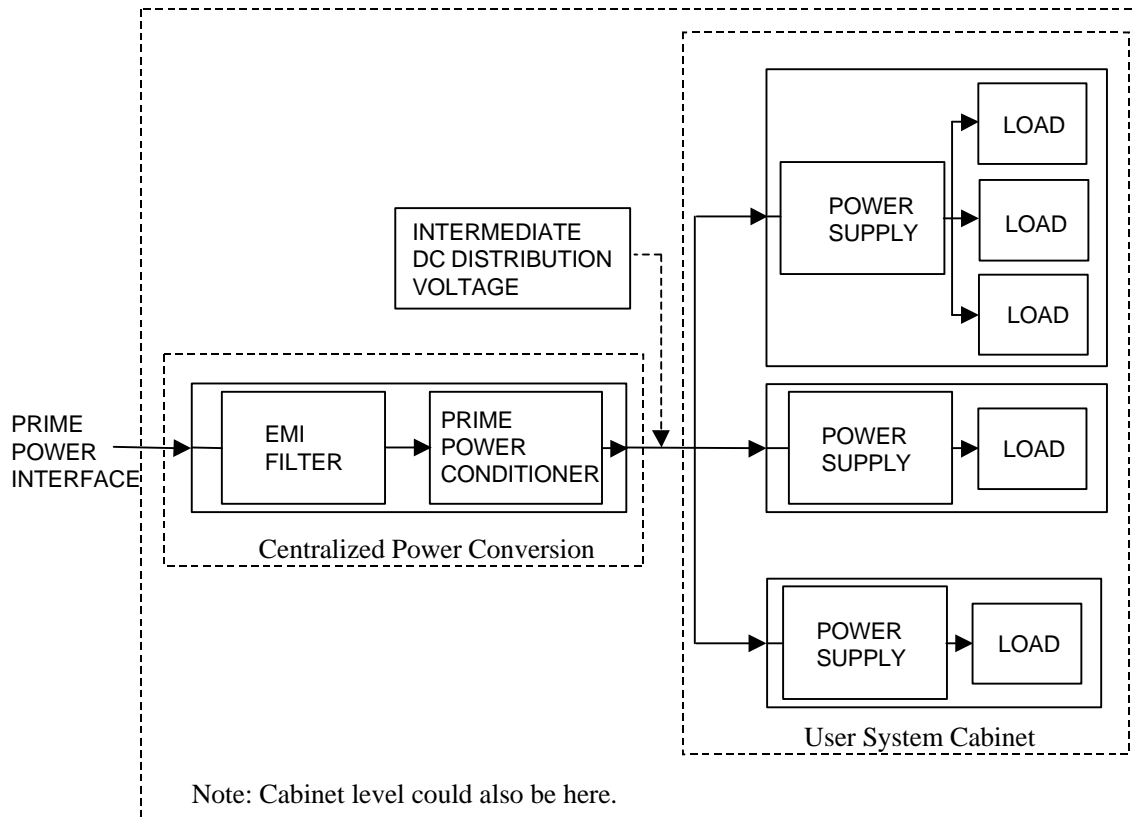

Figure 2.1-3. Distributed Power System

Figure 2.1-3 is a third example of a power system architecture. Power conversion, distribution and regulation are separated into cascaded stages. The centralized power conversion to an intermediate bus may be provided by the platform builder or by the system user. The intermediate bus is usually DC. Internal to a user system cabinet, this architecture is much like the Decentralized Power System. The major difference is that DC/DC power supplies are employed in the user system cabinet. An advantage of this architecture is that the DC/DC power supplies will run more efficiently due to an input bus whose regulation is reasonably tight. Other forms of this architecture are possible based on the system partitioning done by the weapon system contractor working in conjunction with the platform manufacturer.

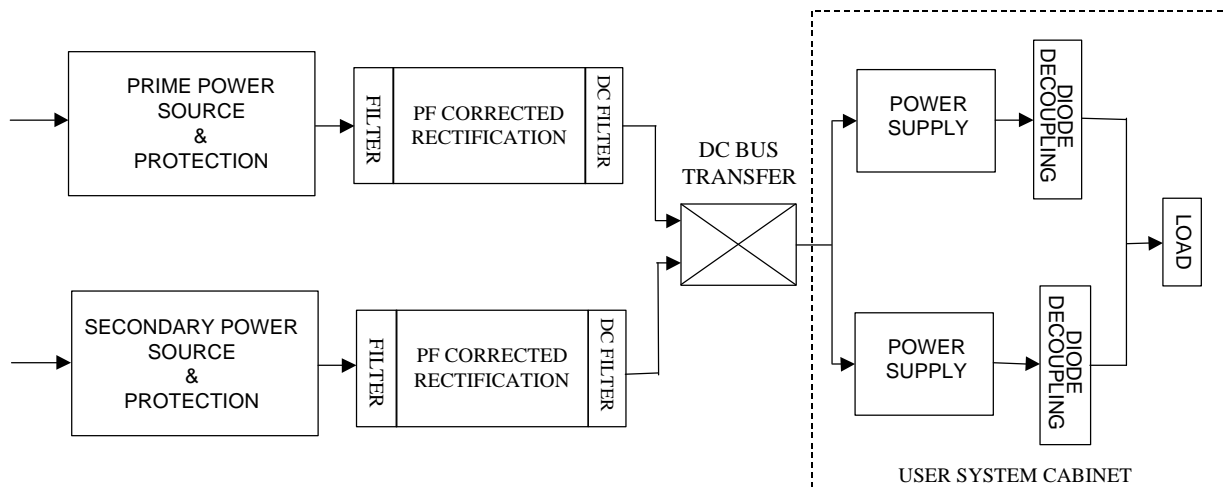

Figure 2.1-4. Fault Tolerant Power System

Figure 2.1-4 illustrates one potential form of a fault tolerant system wherein the prime and secondary power sources are AC. Each of the AC sources drives a regulated power factor correction rectification unit having the necessary input and output filters. Both DC outputs are connected to a DC bus-transfer switch. The DC bus-transfer switch can be made to operate fast enough such that only minimal hold-up energy is required in the individual power supplies. Within the user system cabinet, either power supply can fail and the other will pick up the total load. Another form of fault tolerant system could have a user system cabinet with power supplied by dual AC or DC inputs running in parallel, with an automatic transfer switch to choose between AC inputs or decoupling diodes to choose between DC inputs.

In selecting the appropriate architecture to meet power system requirements, the following performance aspects should also be considered:

- Overvoltage - Ensure that an overvoltage in one power supply does not appear as an overvoltage in a parallel power supply.
- Capture Range - If the capture range is too narrow, field adjustment of the power supplies may be difficult. If the capture range is too broad, the parallel power supplies may follow a failed power supply into overvoltage shutdown.
- Output Voltage Adjustment - The output voltages of the parallel power supplies of each parallel power supply should be identical. Special technology is required to simplify output voltage bus adjustment in the field.
- Load Sharing - Care must be taken in the load sharing circuit to assure that the load sharing continues even if one of the power supplies fails. In most cases the load sharing communications interface is susceptible to external noise and should be carefully filtered.
- Remote Sensing - Remote sensing (after the steering diode) may be used for improved regulation. However, remote sensing may cause load sharing problems and false alarms. For example, if one power supply is adjusted to an output voltage higher than the parallel power

SECTION 2

supply, the power supply set to the higher voltage will assume all or most of the load. The parallel power supply will think the output voltage is too high and may "shut down."

Shutdown may generate a false alarm and a serious delay in the power transfer if a redundant power supply fails. Keep alive circuits are generally required to supplement remote sensing circuits.

- Broken Sense Line Protection - There must always be a requirement for resistive termination internal to the power supply on the remote sense lines to prevent output voltage problems in the event of a broken remote sense line or similar problem including a missing remote sense connection.
- Green Wire Ground - Green wire ground is referred to in the National Electrical Code (NEC) as being the means for providing a safety ground which is normally bonded to a water pipe in a building. For 120 Vrms 60 Hz convenience outlets in ship applications, the "green wire" is bonded to the hull at the distribution center. The 120 Vrms is derived using a single-phase transformer powered from the ship's 440 Vrms service. In these cases, the white wire is also bonded to the hull at the distribution center. For many items, such as test equipment and personal computers, the green wire is provided within the rubber pigtail cord that is plugged into a duplex convenience outlet usually found on a bulkhead. Except in the case of a fault, the green wire does not carry current. The green wire can also be bare copper and satisfy NEC requirements.

Potential problems arise when COTS/NDI power supplies with a single-phase input are connected to one phase of a delta, three-phase, 120 Vrms, 60 Hz source. Metal case power supplies require a safety ground. The voltage difference between the white-wire return and the green-wire ground can then be in the range of 58 to 90 Vrms excluding transients. This potential can damage components, such as filter capacitors, within the power supply that are not rated for this type of application. Furthermore, such an application can potentially cause unbalance in the three-phase system and also result in significant common mode hull current that impacts EMI/EMC. These currents may also cause ground fault alarms. This type of application should require the use of a transformer so that the white-wire return and the green-wire safety ground can be common at one point. System designers and shipyard personnel should work together to ensure a system that performs to the requirements, is safe and does not cause false ground-fault alarms.

2.2 PRIME POWER SOURCE

The procuring agency must establish prime power requirements that are consistent with the constraints of the weapon system. It must be recognized that, in the case of a ship or an aircraft, there may be several sources of prime power and there must be power system compatibility at the interfaces. Universal input power supplies with an input voltage range of 92 - 264 VAC and an input frequency range of 40 - 440 Hz may find application if the remaining parameters are system compatible. The trade-off considerations involved with prime power are discussed in Appendix D, Platform Power Characteristics.

Table 2.2-1 shows some of the common specifications and their typical applications. These are general specifications and the Procuring Agency should tailor these to match unique platform requirements.

Table 2.2-1. Common Military Power Specifications

Power Specification	Power Type	Typical Application
MIL-STD-704	28VDC, 270 VDC 115 VAC 400 Hz, 230 VAC 400Hz	Aircraft, Spacecraft
MIL-STD-1399 Section 300	440, 115 or 115/200Vrms 60 Hz 440 or 115 Vrms 400Hz 440 or 115V or 115/200Vrms 400Hz	Shipboard, Type 1 Shipboard, Type 2 Shipboard limited use-Type 3
MIL-STD-1399 Section 390	155 VDC	Submarine
MIL-STD-1275	28 VDC	Vehicle

2.3 ELECTROMAGNETIC COMPATIBILITY

Electromagnetic compatibility must be accomplished throughout the weapon system by controlling EMI at each power conversion node. EMI requirements and performance are critical to proper system operation, and are specified in MIL-STD-461. A common mistake is to impose full compliance with these requirements at the power supply level, whereas the power supply is only one of the system components contributing to EMI.

Overall weapon system performance may be affected by the introduction of EMI filters external to the individual power supplies. Voltage excursions as seen by the actual power conditioning circuitry can be vastly different with the introduction of filters, particularly under dynamic load conditions. Power system specifications must clearly define the input power characteristics at the power supply such that the interface can be established, including the effect of isolation transformers, additional power supplies or a common EMI filter.

COTS/NDI equipment is often tested for FCC compliance. The user should not assume that the FCC compliance implies MIL-STD-461 compliance. Currently, FCC requirements are not consistent with MIL-STD-461. For instance, in contrast to the MIL-STD-461 CE101 spectrum that starts at 10 kHz, the conducted spectrum in the FCC specification starts at 450 kHz. The switching frequency of most power supplies is below the range controlled by the FCC. Similarly, the FCC radiated limits begin at 30 MHz while the military limits start at 10 kHz.

The complex interactions between EMI filters and power supplies are often discovered during system integration, when the resolution can be difficult to achieve, time consuming and costly. Wherever possible, simulation techniques should be employed to avert this situation. The simulation must include the source, distribution, and power supply load characteristics, as well as elements of resistance and parasitic reactance.

SECTION 2

Poor grounding and bonding design practices often degrade an adequate filter design. Consequently, power supplies can have adequate differential mode suppression but exhibit excessive common-mode noise.

2.4 MONITORING AND CONTROL

Monitoring and control requirements for power supplies vary widely from system to system. It is common to encounter interactive requirements between the system and the power supply for monitoring operational status and for controlling various functions, either independently or as a function of monitor status. A balance should be maintained between the degree of monitoring and control at both the power supply and system levels to avoid unnecessary power supply complexity.

Interfaces between the user, the system, and the power supply may be mechanical, visual, or electrical. Interface requirements address the receiving or sending of signals between the system and the power supply. Voltage levels, impedance and timing must be specified for each interface. Grounding and common-mode noise must be controlled.

Monitoring requirements may include information provided by the power supply to indicate status of:

- Input power availability
- Output status
- Load conditions
- ON/OFF commands
- Sequencing or independent control of multiple outputs
- Switching frequency synchronization
- Control functions related to power supply or environmental status
- Voltage and current programming
- Load sharing
- Battle Short
- Input power failure alert

2.5 ENVIRONMENTAL ISSUES

It may not be sufficient or realistic to flow down the environmental requirements of a system directly to the power supply specification. This can result in a power supply that is over-specified for some environments and under-specified for others.

To avoid surprises and maintain potential for the lowest practical TOC, it is essential that the power supply interface requirements reflect the conditions of the power supply in the operating environment. This requires the system designer to determine how the power supply environmental conditions are influenced by the presence of the other elements of the system. This can be done by analysis and/or verified empirically.

2.6 SPECIFYING LOAD POWER

The power supply load requirements are derived from the system load analysis. System load power requirements are derived from an appropriate methodology using accurate load estimates. It is important that the margin, as related to load current, is only included at one point and not compounded by each level of design activity. This will result in an optimum power supply design for the system load. An over-specified power supply will result in an inefficient use of system volume, weight and power resources at increased cost.

The following are considerations used to approximate system loading.

- Parameters - Average, minimum, peak, and dynamic loading needs to be accurately specified. The specification of these parameters must include the load characteristics, such as passive, reactive, and regenerative loads.
- Interactions - System loads are often specified without placing a requirement on the effect of cross regulation. Specifying the allowable degree of cross regulation for the individual system loads becomes an influencing factor with regard to the overall power supply implementation.

2.7 PROTECTION

Power source faults can cause failures in a power supply. Conditions such as loss of phase, under and over voltage, reverse polarity (DC input), and incorrect phase sequence should be identified in the power supply specification and addressed during the design phase.

Power supply faults can damage the power distribution system. When one of the power supply components fails, fault currents may flow through distribution wiring and input filter components. Input wiring should be properly protected with a coordinated set of protection devices. More than one set of current interrupt devices may be required between the power source and system because current carrying capacity drops as the power is distributed. This is especially true of higher power equipment. Components, wiring and circuit traces within the power supply that may have to conduct fault currents should also be designed to survive. Additionally, voltage transients, generated when the circuit protective devices interrupt, should be considered in the design.

SECTION 2

Components in the power supply control circuits can fail creating over-voltage or incorrectly sequenced output voltages. These could damage the load. Also, failures in interface circuits may allow undesirable or dangerous system operating modes. The design should be reviewed for single point failures or sneak paths. Redundancy and fail-safe operation in these circuits should be evaluated.

Since switching power supplies present a constant power load to the power source, the source current will increase with a reduced source voltage. The worst case current should be considered as part of the overall protection approach.

2.8 TESTING

The power system should be tested under the prime power constraints to verify performance and EMI/EMC compliance. The power system and power supply performance is dependent upon the connected load characteristics. Proper power system verification includes the distribution system, connector interfaces, and reactive and other active elements.

EMI testing is performed along with environmental testing to show that the equipment is capable of providing satisfactory performance aboard a particular platform where sources of electromagnetic emissions are present. System level interactions can result in unstable operating modes, degraded performance, and in the extreme, catastrophic failure of system components.

Transient testing is conducted to determine the ability of the power system to operate and survive voltage and frequency transients encountered while operating under platform power. Both AC and DC power systems are subjected to Steady State, Normal and Abnormal Transient Tests. In addition, AC power systems are also subjected to frequency transients. The power supply performance requirements during system level fault and other abnormal operating conditions must be detailed in the system level test plan and power supply specification.

Section 3

Low Voltage Power Supplies

3.0 Objective

This section provides guidelines for designing, verifying and manufacturing Modified COTS/NDI and Custom low voltage power supplies. The focus of this section is directed toward understanding the relationship between selecting the topology, developing hardware and manufacturing power supplies compliant with the power system architecture. This understanding is necessary to determine best value, i.e., lowest price versus maximum performance. The development of low voltage power supplies to provide various power conversion functions has evolved from utilization of discrete components to high density modules. This section addresses both discrete component and modular topologies. Key disciplines required to develop and manufacture a cost effective power supply are illustrated in Figure 3.0-1.

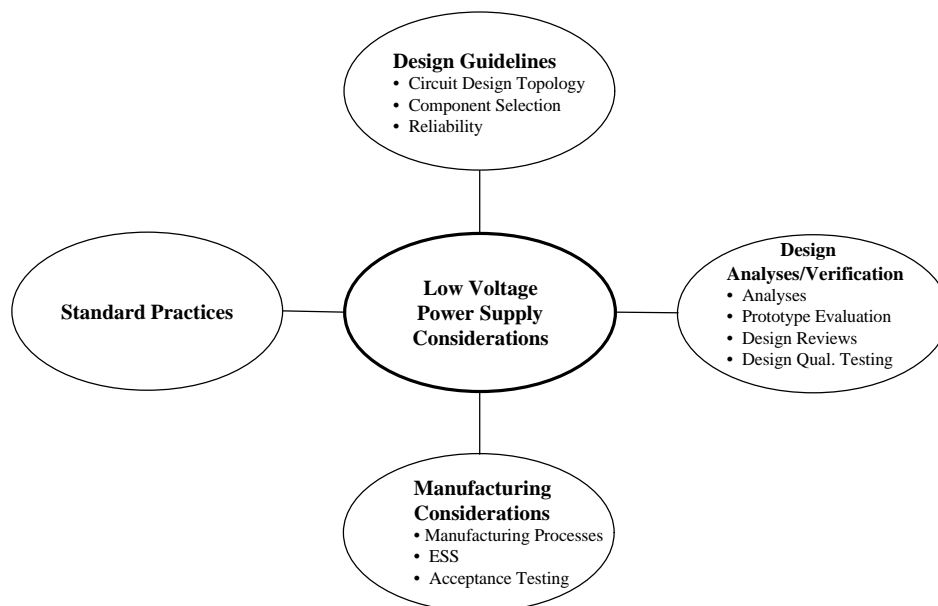

Figure 3.0-1. Factors in the Development of a Cost Effective Low Voltage Power Supply

3.1 Design Guidelines

Power supply design begins with an understanding of the performance, environmental, interface and system requirements. After the requirements are understood, the guidelines contained in the following subsections should be implemented:

- 3.1.1 Circuit Design Topology
- 3.1.2 Component Selection
- 3.1.3 Reliability

3.1.1 Circuit Design Topology

At onset of the initial design, the development activity should examine candidate topologies consistent with the required power level. Considerations that should be continuously addressed during this phase of the low voltage power supply development include the imposed electrical steady state and transient component stress as well as operational environments. Although a power supply circuit may be fully compliant at the breadboard stage, parasitic reactive components may contribute to unexpected common mode noise after the circuits are physically packaged. This is particularly apparent at switching frequencies in excess of 200 kHz. A weapon system inherently susceptible to narrow band noise can be improved by fixed frequency, synchronized power conversion. The power supply design should incorporate fault tolerant features so that the power supply will continue to operate, with degraded system performance, even though the external synchronization clock fails.

Other design factors that should be considered are component and functional redundancy. If the power supply developing activity has selected a module topology, redundancy is easily implemented through the application of identical, decoupled, fault tolerant modules with fail-safe failure modes.

In addition to traditional environmental qualification testing to verify power supply designs, this document addresses the use of Highly Accelerated Life Testing (HALT) as a cost effective means for discovering failure modes caused by inadequate design and component performance margins.

3.1.2 Component Selection

The development and availability of state-of-the-art active and passive components offer consistent improvements in cost and reliability of low voltage power supplies. The application of these components must remain consistent with the environmental constraints of the weapon system. There are a number of issues to consider in the selection of components for low voltage power supplies, as follows.

Component Derating

Component derating is a proven method for improving reliability and operational life by reducing operating stresses below the manufacturer's recommended maximum ratings. Depending upon the specific component type, construction and materials used, stress may include voltage, current, temperature and power dissipation, as well as other stresses imposed in the local environment.

Voltage and power derating are separate and independent considerations. Voltage derating is applied to reduce failures caused by electrical breakdown, whereas power derating is accomplished to reduce thermal stress.

The operating voltage of active components, such as semiconductors, is dependent upon the breakdown characteristics of the physical properties. The conservative voltage derating of passive components prevents breakdown, flashover and corona effects at the atmospheric pressure (altitude) to which the components are exposed. These effects are dependent upon voltage gradients, configuration of terminals and the nature of the dielectric path.

The degree of heat transfer from a heat-dissipating component and the local environment surrounding the component will determine the surface temperature, junction temperature, core temperature or hot-spot temperature at a particular power level. For optimum life, junction temperatures should not exceed $+110^{\circ}\text{C}$ under worst-case operating conditions. The maximum operating temperature for each component in a power supply should be determined analytically and verified empirically. In addition, semiconductor and integrated circuit peak junction temperatures, and magnetic components and capacitor peak core temperatures must be accurately determined. Appendix E, Parts Derating Tables, presents guidelines for component stress derating recommended for the design of reliable power supplies.

Component Packaging

A high density design, using innovative packaging techniques can result in improved reliability compared to older technology. There are several components used in power supplies that require special design and manufacturing considerations to assure adequate reliability and minimize failure modes in a cost effective manner.

Plastic Encapsulated Devices - The successful application of Plastic Encapsulated Devices (PEDs) requires that the imposed actual environments and available PEDs specifications are well matched throughout the product life cycle. Currently, PEDs are not recommended for some applications, e.g., critical applications such as man-rated, space, radiation hardened and long term dormant storage. Currently, there are no validated models for making long-term dormant storage PED predictions.

Power Semiconductor Isolation and Thermal Conditions - Since power semiconductors typically do not have isolated junctions, it becomes necessary for the power supply manufacturer to provide a reliable method of mounting these devices with low thermal resistance while establishing high electrical isolation. Various materials and techniques have been used, each with their unique problems. Thinner materials, such as mica and mylar film are subject to

SECTION 3

damage by burrs and sharp edges. High thermal conductivity ceramic insulators require thermal grease and, because of their brittleness, are easily broken. The use of thermal grease should be avoided as it is difficult to control, attracts contaminants and affects reliability and maintainability.

Special Procurement Procedures - All components should be capable of withstanding worst-case electrical, mechanical and thermal stress conditions. Nonstandard components are obtained through strict procedures maintained by power supply manufacturers in their procurement specifications. Modified standard components are similarly controlled but only for selected items and/or parameters. Common procedures used by most power supply manufacturers include:

- vendor evaluation based on prior performance and history,
- test to acceptable quality levels or 100% test,
- sample Destructive Physical Analysis (DPA) and periodic inspection, including construction and electrical performance to determine component strengths and weaknesses, and
- documentation of component problem histories to restrict future usage of known problem items.

3.1.3 Reliability

Reliability of the power supply is determined by the design process. Increased reliability can be achieved by several techniques, including:

- proven circuit designs,
- quality assured components,
- electrical, mechanical and thermal component stress derating,
- minimizing junction/hot-spot temperatures,
- redundant components and circuit functions,
- automated assembly processes which require a minimum of hand assembly and minimum of point-to-point wiring,
- HALT as part of the design process, and
- design verification testing.

Design for reliability requires examination of failure mechanisms during the design process. This examination should include a consideration of component failure rates, the use of component selection and stress reduction to minimize failure rates, and the effects of component parameter variation. Most high reliability power supplies exhibit a capability for component tolerance variations much greater than the selected component's design specifications.

MIL-HDBK-217, Bellcore TR-332, and other reliability prediction/data sources may be useful in making trade-offs during the design and/or evaluation of power supplies. Component stress analysis should address transient conditions, such as transistor load line variations and various

peak power, voltage, and current surges as well as steady state conditions. Maximum semiconductor junction temperatures and maximum magnetic and capacitor core temperatures must be below those recommended in Appendix E.

Power supplies designed and manufactured under the guidelines presented herein should be capable of reliably meeting the performance requirements in the environments for which they are designed.

Design Techniques

Design techniques which should be considered include:

Metal-Clad Wiring Boards - The application of metal-clad PWBs should be carefully examined. Although the metal-clad PWB offers a very low thermal impedance for the power dissipating semiconductors, it also is a means of externally coupling the common mode switching noise. This noise is capacitively coupled to the system conductive cooling surfaces. Discrete, common mode attenuation capacitors should be provided between the module electrical interfaces and system ground.

Surface Mount Technology - The use of surface mount technology should be considered in the development of both modified COTS/NDI and Custom power supplies. Surface mount components have a much lower effective series resistance. The application of other passive surface mount components minimizes the effective thermal resistance to the dissipating interfaces.

Electrical Interface - The external electrical interfaces of high density modules should take into consideration the possibility of corrosion. Since the modules ultimately will be plugged into the system interconnect board for a long period of time, the interface will not have the advantage of self cleaning through a wiping action, as compared to the action of switch contacts. Therefore, mating surfaces of module pins and accompanying sockets should be gold plated.

Physical Design - Conduction cooling to a system heat exchanger is the preferred method for module heat dissipation. The footprint or baseplate area should be maximized to provide a low impedance path from the internal dissipating components to an external system surface. The thermal dissipating components should be distributed proportionally over the module's baseplate to preclude hot spots. If the module is encapsulated, the encapsulant should be made with a thermally conductive material to distribute the thermal dissipation of those components that do not directly interface to the module baseplate.

Electromagnetic Interference Management - Although management of EMI/EMC is always important, the allowable levels depend upon the application and overall system requirements. Levying a requirement for "full MIL-STD-461 compliance" at the power supply level imposes a significant burden on the power supply designer due to the internal volume that must be set aside for filtering. To avoid unnecessary costs and volume allocation, the following areas should be addressed:

SECTION 3

- The EMI specification should be tailored to actual subsystem requirements. Specific bands of frequencies that are critical to system operation, and, hence where EMI suppression is critical, should be clearly identified. Allowable EMI/EMC levels should reflect real system needs.
- Allocation of EMI/EMC filtering must balance the needs of interference suppression with the potential for introduction of undesirable interaction between individual power supplies. When multiple supplies are fed from a single filter, the series impedance of the filter can cause load current fluctuations and input current harmonic energy from one supply to modulate the common supply bus, degrading the performance of other supplies. Filters should only be used with power supplies that have been demonstrated to generate, or be susceptible to, EMI in the system. Where space permits, individual filters should be used for each such supply. If other constraints demand that multiple supplies share a common filter, the filter must be designed taking all of the supplies and their characteristics into account.
- The physical layout of the housing and cabling within the power supply should be designed to provide adequate shielding to prevent EMI radiating from individual power supplies from escaping the cabinet and from coupling onto system cabling, where it could leave the cabinet as conducted EMI.
- In those cases where a common input filter is shared among several power supplies, a worst case stability analysis must be conducted. This analysis must examine whether the interface between the filter and the supplies satisfies the negative impedance criteria for stability. This criteria is based on ensuring the source impedance magnitude of the source is less than the combined worst case load impedance magnitude to the highest crossover frequency of any of the power supplies.

Other Design Considerations

Some systems, particularly those containing signal-processing memories, require an electrical warning signal in advance of an output power failure. This warning signal is usually generated at the time prime power degrades below a predetermined level, whereas the output power continues for a period dependent upon the energy stored within the power supply. Energy storage requires volume, so it is advantageous from the standpoint of power density and reliability to specify the minimum hold-up time required. To minimize stored energy, a desirable technique is to partition system power into critical (requiring hold-up) and noncritical outputs. Other considerations include:

Performance Monitoring/Fault Localization (PM/FL) Built-In-Test-Equipment (BITE) – PM/FL and BITE circuitry can increase component count, complexity and development time. The need for PM/FL and BITE within or external to the power supply should be carefully weighed against the resultant increase in circuit complexity and component packaging density.

Crowbar Overvoltage Protection - Retain overvoltage protection, but eliminate the crowbar requirement for isolated switching supplies. Modifying or terminating the switching action may provide positive protection for most requirements. By terminating the switching action, relative to overvoltage protection, automatic operational reset of the power supply is provided. If a crowbar is removed, adequacy of load protection should be reassessed (e.g., FMECA/SCA).

Isolated Multiple Outputs - Allow all outputs to be connected to a common return point within the power supply. Some systems require isolation to eliminate a ground-loop, with the output returns ultimately connected at remote points. In these systems, specify the maximum voltage difference between electrical returns. This will minimize the number of internal auxiliary power supplies needed for post regulation circuitry.

Source and Load Compatibility - The negative input impedance characteristic of switching power supplies can cause system instability if not correctly matched with the associated source impedance. This source impedance is that impedance seen by the power supply input terminals. Also, the real power source characteristics can vary significantly from the specified power source as a result of EMI filtering, the power distribution system, generators, power monitor and control devices, and other electronic equipment installed on the same power bus. An adequate characterization of the source impedance is required to reduce risk at system installation.

3.2 Design Analyses/Verification

Design analyses are essential to the achievement of early design maturity and should be completed prior to the power supply Critical Design Review. Verification of design maturity is accomplished by appropriate testing. Guidelines on the foregoing are presented in the following subsections:

- 3.2.1 Analyses
- 3.2.2 Prototype Evaluation
- 3.2.3 Design Reviews
- 3.2.4 Design Qualification Testing

3.2.1 Analyses

Analyses performed to achieve early design maturity include, but are not limited to, stress and stress/strength, worst case tolerance, sneak circuit, failure modes and effects, and thermal analysis. Additional details may be found in NAVSO P-3686, related Government publications, and corporate design policies.

One example of the type of details that should be pursued is represented by worst case analysis. Worst-case parametric variations on regulator control loops must be identified and characterized. Parametric sensitivities of critical components must be identified. Thermal analyses should be performed for worst-case environmental conditions.

Worst Case Analysis (WCA) is a powerful tool for minimizing the degradation of system performance. When properly done, WCA minimizes system failures due to variation in component parameters caused by factors such as environmental effects and aging. A WCA is a rigorous analytical evaluation of a circuit's performance, considering the simultaneous existence of worst case conditions for all components. WCA requires a detailed database for all

SECTION 3

component parameter variations which could affect circuit or system functions. The analysis is necessary to achieve high-reliability circuit design.

Another consideration pertaining to design analysis is the use of computer aided design and analysis tools to facilitate the analysis process. In this regard, the following should be considered:

- Circuit simulations are useful for design and verification and must include circuit performance and component stress analyses relative to all large signals (e.g., voltage and current step). Small signal analysis is useful but only valid for the selected static operating points. Both switch frequency simulations and averaged models should be used to support the analyses. Circuit simulations should be validated by empirically measured data. Once validated, circuit simulation can be used to investigate both steady-state and transient stresses which are extremely difficult to obtain by direct measurement on power conditioning components. Furthermore, component parameters can be varied to facilitate design trade-offs. Although validated power supply circuit simulations require significant engineering effort, the simulations are significantly more versatile for evaluating design and component changes compared to the use of circuit breadboards.
- Finite element analysis during the design process is useful for evaluating mechanical, structural, and thermal performance. To validate the analyses, at least two element resolutions must be used to establish the rate of convergence of the solution.

3.2.2 Prototype Evaluation

Bench testing should be performed to characterize the power supply for operating conditions and test scenarios that are difficult to analyze. Critical component stress conditions identified through analyses should be characterized. In addition, noise, ringing voltage and current effects on the principal power conditioning components and control circuits should be identified and characterized. The following tests should be performed for each modified COTS/NDI or Custom power supply:

- Electrical performance
- Thermal and vibration surveys
- Limited environmental testing

3.2.3 Design Reviews

Design reviews are a powerful tool that can be used to help manage technical risk. These reviews allow program managers to maintain visibility of the status and progress of the power supply development activity in meeting the requirements and to initiate corrective action if warranted. For COTS/NDI, an understanding of the power supply vendor's development processes provides insight into the design and its technical acceptability. Appendix C, Modified

COTS/NDI and Custom Power Supply Supplier Evaluation, provides a means of evaluating a potential power supply vendor.

For Modified COTS/NDI and Custom power supplies, design reviewers should consider the Design Review Checklists for Power Systems and Power Supplies contained in Appendix B. The following best practices should be followed for effective design reviews:

- Include funding for design reviews in the program budget.
- Assign expert technical personnel independent from the specific hardware being reviewed.
- Perform design reviews after the completion of the power supply development schedule milestones. A reasonable degree of flexibility in scheduling should be provided such that the activities associated with the milestones are indeed completed.
- Have an effective, detailed agenda. The agenda should be generated and agreed upon by the procuring agency and the power supply developer well in advance of the design review. The agenda should delineate very clearly the items to be covered and should include the format in which the information will be presented.
- Provide a design review package to the procuring agency in sufficient time prior to the review so that the members of the review team can be prepared.

The following provides a brief description of typical reviews conducted during the design process.

Conceptual Design Review

The purpose of a conceptual design review (equivalent to a Systems Design Review for a major weapon system) is to ensure that there is agreement on the power supply specification, that all questions have been answered and that the development plan as well as the overall design concept is understood by all. Those actions that must be completed prior to a Conceptual Design Review are:

- Proposed performance specification.
- Design concept in block diagram form with written description provided to reviewers prior to meeting. This includes electrical, mechanical, and thermal considerations.
- Draft development milestone chart.

Preliminary Design Review

The primary objective of the Preliminary Design Review (PDR) should be to evaluate the progress of the preliminary design and its compliance with the specified requirements. See the Appendix B Checklists for specific guidelines.

Critical Design Review

The primary objective of the Critical Design Review (CDR) is to determine that the power supply is properly designed and ready for release for manufacturing. All actions from the PDR should have been closed prior to CDR. See the Appendix B Checklists for specific guidelines.

SECTION 3

Production Readiness Review

Although the Production Readiness Review (PRR) is not actually a design review, it is included because producibility of the design is a major concern. The prime objective of the PRR is to evaluate the adequacy of the processes, procedures, tools and training which apply to manufacturing the power supply. The activities and/or milestones that should be addressed include, but are not necessarily limited to:

- All action items from the CDR should be closed.
- Manufacturing documentation (e.g., machining and assembly drawings and travelers) is complete.
- Tool design (e.g., assembly fixtures and wire harness mockups) is complete.
- Quality assurance provisions are documented.
- Test procedures (e.g., in process procedures for subassemblies and final test) are complete.
- Processes (e.g., workflow, conformal coating of boards, in-process inspection) are in place.
- Plans for environmental stress screening are complete.
- Plans for training power supply production personnel are in place.

3.2.4 Design Qualification Testing

Design qualification testing should be conducted to verify that the design meets the performance requirements. However, the most frequently overlooked aspects of power supply qualification testing are:

- verification that the power supply input impedance is compatible with the source impedance,
- verification that the power supply is interfaced to the intended system static and dynamic load characteristics, and
- replication of thermal cooling paths.

As an integral part of qualification testing, power supplies should be subjected to Highly Accelerated Life Testing (HALT), one of the more effective means of ensuring early design maturity. Highly Accelerated Life Testing (HALT) is an iterative step process consisting of applying progressively higher stresses to induce failure, analyze the root cause of failure and develop corrective actions, then further increase stress to induce additional failures. Through this step process, marginal designs are identified and remedied. This process is continued until sufficient design margin has been achieved. The stresses applied to the units under test may be substantially greater than worst-case specification conditions. The goal is to identify and remove “weak links” in the design. This process can also be used to evaluate COTS/NDI products.

3.3 Manufacturing Considerations

Effective power supply production begins with identification of critical manufacturing processes. These processes are crucial to sustaining the reliability of the power supply design during manufacturing and should be documented in the manufacturer's quality plan. The following sections present guidelines that are applicable to low voltage power supplies:

- 3.3.1 Manufacturing Process Considerations
- 3.3.2 Environmental Stress Screening
- 3.3.3 Acceptance Testing

3.3.1 Manufacturing Process Considerations

Component Receiving Inspection

Effective receiving inspections prevent detrimental impact to performance, schedule and cost resulting from installing defective components. Testing and inspection of components may include the following:

- Electrical
- Hermeticity
- X-ray
- Particle Impact Noise Detection (PIND)
- Sample Destructive Physical Analysis (DPA) and periodic inspection

Each lot that does not successfully pass all required tests and inspections should be returned to the component manufacturer with written notification as to the cause for rejection. A formal reply stating the corrective action intended should be required by a specific date. The test data, manufacturer's notification and his response should be recorded as component performance history.

Component Mounting

Components should be inserted via automatic or semiautomatic insertion equipment whenever possible to prevent improper insertion of components. If such equipment is used, the sequence and placement of components should be validated by "first piece" inspection. The accidental application of high voltage pulses must be prevented when using this equipment for automatic polarity checking. Components that are sensitive to ESD or voltage transients should be protected as described later in this section.

Mounting of power devices requires special consideration. Potential reliability gains by utilizing thermally conductive plastic impregnated fiberglass isolators can be destroyed if proper torquing requirements are not precisely followed. Too much pressure can rupture the isolator, thus allowing an electrical short to develop between the "hot-case" device and heat sink. Too little pressure will result in poor thermal conductivity and, hence, a higher semiconductor junction

SECTION 3

temperature. Great care must be taken in selection and installation of shoulder washers to obtain proper pressure. Manufacturer's guidelines can be used to establish torque requirements; however, caution should be exercised because of the wide variation in pressure obtained as a function of the mechanical resistance between the screw head, or nut and the washer or other bearing surface. Experimental results may be required to obtain the optimum torque required.

Solder Joints and Solder Processes

Solder joints and processes should be performed in accordance with IPC-A-610 or ANSI/J-STD-001.

A key precondition to a good solder joint is pre-tinning of all leads/pins prior to assembly. For maximum reliability and consistency, the solder joints should be made via automated processes such as:

- wave solder for pin-in-hole connections, and
- semi-automatic for surface mounting (e.g., flatpacks).

All solder joints should be inspectable. This requires that blind-hole solder joints be minimized in the design. For pin-in-hole solder joints, the solder should penetrate through the barrel of a Plated Through Hole (PTH). This applies also to wires, transformers, connectors, and other related items, and requires that the solder joint be made from the side of the Printed Wiring Board/Multi-layer Interconnect Board (PWB/MIB) opposite that on which the component is located.

Make all wire connections to a PWB/MIB only on the component side of the PWB/MIB to simplify assembly, rework and repair, and to minimize handling damage. Flux must not become entrapped due to a blockage at one end of the PTH. This has a high potential for causing a poor solder joint which will fail at a later time. Cavities are a natural place for moisture, foreign material, or solder to get trapped and/or wedged, resulting in an electrical short to the frame. This can be prevented by:

- designing the cavity out,
- making the cavity sufficiently large so as to reduce the risk of entrapment,
- coating the area to prevent the short from occurring, or
- a combination of the latter two techniques.

ESD Considerations

If not controlled properly, ESD can destroy electronic devices instantly or have latent effects which can lower the life expectancy of a device. Static discharge can vaporize conductors and rupture insulators within electronic components. This can result in an open or short circuit. In a lab or factory environment, the goal is to prevent charge from building up to a damaging level. In designing circuits, the goal is to minimize vulnerability to static discharges and to slow the rate of static discharge to ensure no harm is done.

There are numerous ways ESD can be controlled in a lab or factory environment. Personal ground straps (wrist, leg, or ankle) should always be worn when handling circuit boards and devices. These straps provide ESD protection by providing a path to ground for potentially dangerous charges. The workbench also should have an ESD protective (static dissipative) work surface over the total area where boards or devices will be placed. This surface should be connected to ground. It is recommended that each workstation have monitoring equipment, which continually tests the ground integrity of the work surface and wrist straps. If gloves must be worn, cotton or ESD protective materials are preferred. Keeping the level of relative humidity above 40% will also help in controlling ESD.

Devices should be stored such that all exposed leads are held at a common potential. Devices inserted into conductive foam are a common way to store such items. Items should be placed in antistatic bags or other appropriate containers. Items should be removed from their protective packages within the confines of an ESD work area. Prior to removing or handling sensitive components, neutralizing the ESD package by placing it on a grounded workbench or by touching the package while grounded is also good practice.

Uninsulated hand tools or static controlled hand tools are preferred for use in an ESD safe work area. Insulated hand tools should be discharged to a conductive mat before being used. When using multimeters, momentarily ground the probes prior to circuit connection.

Do not insert or remove static sensitive devices with power applied. This is especially true for MOS devices. Additional MOS precautions include:

- Do not apply an input signal while the MOS power is off
- When testing MOS devices, connect all unused input leads to either ground, Vdd, or Vss, whichever is appropriate for the circuit involved.
- Prior to performance of dielectric or insulation resistance tests, remove MOS devices from the equipment if possible.
- When designing circuits with MOS devices, a small amount of series resistance can slow down the rate of static discharge.

While in the vicinity of static sensitive items, personnel should avoid physical activities which are static producing. Such activities include wiping feet, removing or putting on smocks, or pulling tape from a tape dispenser. The workstation should be kept as free as possible from static generators. Work instructions, test procedures, drawings, and similar documents used in ESD protected areas should be stored in anti-static covers. Common plastics, untreated styrofoam, and similar static generators shall be kept a safe distance from the work station area. Static generators which are essential to the activities being performed should be used with proper precautions taken.

Assembly Level Processes

The following assembly level manufacturing processes require special consideration:

SECTION 3

- Verify the compatibility of components with solvents used during the manufacturing process.
- Care must be taken in the decisions to use a wire (or harness) and its placement and routing to avoid broken and/or pinched wires, especially during or after a rework/repair operation and to prevent crosstalk.
- Consideration of fixture and container design and the use of adequately trained personnel can reduce handling damage substantially during assembly and rework/repair operations.
- Inspection and assembly personnel should have adequate visual aids for use in verifying their completed work at each stage of assembly. The initial build personnel should ensure workmanship errors found during the inspection process are corrected.

3.3.2 Environmental Stress Screening

Environmental Stress Screening (ESS) is a process which involves the application of one or more specific types of environmental stresses for the purpose of precipitating to failure, any latent, intermittent, or incipient defects or flaws which would cause product failure in the use environment. The stress may be applied in combination or in sequence on an accelerated basis but within product design limits. ESS detects manufacturing problems caused by poor workmanship or by faulty and/or marginal parts. It also identifies design problems if the design is inherently marginal and if qualification and engineering tests were too benign. The most common stimuli used in ESS are temperature cycling and random vibration.

ESS is a process rather than a test in the normal accept/reject sense. Those participating in the effort, including the contractor, should never be led to believe that a "failure" is bad and would be held against them. ESS is intended to stimulate defects, not to simulate the operating environment, and therefore, factory "failures" are encouraged. The root causes of ESS failures need to be found and corrected before the ESS process is complete.

Initially, ESS should be applied to 100% of the units manufactured, including repaired or spare units. By using a closed loop feedback system, data can be analyzed to determine whether the screening program should be modified. A viable ESS program must be dynamic - the screening program must be actively managed and tailored to the particular characteristics of the equipment being screened. This includes conducting a survey to determine the mechanical and thermal characteristics of the equipment and refining the vibration and temperature screening profiles as more information becomes available and/or designs, processes, and circumstances evolve. There are some specific engineering considerations for determining optimal ESS stress levels and for making a sound engineering decision that tends to be on the conservative side. Two such considerations are:

- Differences in physical characteristics, such as thermal inertia, thermal conductivity, mechanical coupling, and mechanical resonant frequencies, assure that differently configured assemblies will respond differently to identical thermal and vibrational inputs.

- Stress profiles should be defined in terms of responses rather than input. A uniform level of stress may not be achieved throughout the unit, because all units are not generally internally homogeneous. The response can be specified and measured at only a few points, so it will still differ locally within differently configured assemblies.

Baseline ESS Procedures

Tri-Service Technical Brief 002-93-08 “*Environmental Stress Screening Guidelines*” contains guidance for development and performance of ESS. Baseline random vibration and temperature cycling profiles are discussed below.

The baseline profiles for random vibration and temperature cycling, contained in the Tri-Service Technical Brief, are *not* recommended stress levels, and should be used only as starting points for any type of electronic equipment to develop unique optimum profiles for a particular equipment, e.g., power supplies. They should be refined after conducting surveys to determine the mechanical and thermal characteristics of the particular equipment being developed. For any given part or production process, there exists a level of ESS stress that is optimal, i.e., maximizes the likelihood of flaw detection without significant degradation of the unit undergoing ESS. Optimization, if not planned and done properly for power supplies which generate more heat than the typical electronic equipment, could be a major consumer of resources. Experience with similar hardware can be helpful in setting initial tailoring levels leading to a rough approximation of optimal parameters. However, a true optimization is likely to require an extensive, carefully planned effort.

Vibration - The excitation must be tailored to the response experienced by the components of the unit under test. The selection of stress levels must be based on available survey data and structural design due to the potential for highly resonant members, as well as the existence of vibration sensitive devices. To avoid potential fatigue or peak level damage, some reduction of the input spectrum may be preformed at points of resonant frequencies which result in amplification of the applied stress by a factor of 6 dB or more. These resonances would be identified from data accumulated during development tests, or by conducting a low-level sine sweep.

Notching of damaging resonant frequencies should not be permitted without customer concurrence, and should be the exception, not the general rule. Where warranted, temporary stiffening of the unit should also be considered to prevent overstressing during the stress screen. The contractor may find that the most economic approach is a minor design change to provide permanent stiffening. Whether temporary or permanent, the stiffening should be done in a manner that achieves the desired flat response throughout the unit being screened.

Random vibration characteristics commonly used include:

- Overall response level: 6grms
- Frequencies: 20 to 2000Hz

SECTION 3

- Axes: 3
- Duration: 10 minutes/axis if performed sequentially or 10 minutes total if done simultaneously.
- Product Condition: Powered and monitored

Temperature - Temperature cycling screens require tailoring, based on survey results, to each specific equipment. Differences in components, materials and heat dissipation lead to variations in the thermal stresses throughout the equipment. Effective screening usually requires large, rapid temperature changes. Such thermal cycling is used for the detection of assembly flaws that involve installation errors or inadequate chemical or mechanical isolation or bonding. Under rapid thermal cycling (e.g., in solder joints), differential thermal expansion takes place without sufficient time for stress relief, and this is a major mechanism for precipitating latent defects to detectable failures.

Typical electronic equipment temperature cycling profile values include:

- Temperature range: -40°C to $+70^{\circ}\text{C}$
- Rate of change: $5^{\circ}\text{C}/\text{Minute}$ to $20^{\circ}\text{C}/\text{Minute}$
- Number of cycles: 12 to 20
- Stabilization: Stabilization occurs when the temperature of the slowest responding element in the product being screened is within 15% of the specified high and low temperature extremes. Large magnetic parts should be avoided when determining that stabilization has occurred.
- Product Condition: Equipment should be powered and monitored. Power is applied during the low to high temperature excursion and remains on until the temperature has stabilized at the high temperature. Power is turned off on the high to low temperature excursion until stabilization at the low temperature. Power is also turned on and off a minimum of three times at the temperature extremes on each cycle.

All temperature parameters pertain to the temperature of the unit being screened and not the chamber air temperature. The temperature parameters of the unit being screened are usually determined by thermocouples placed at various points on the unit being screened.

After the baseline temperature cycle profile is tailored for a particular equipment, based on survey results, the actual profile is developed and applied. Each output of a power supply should have a static (characterized) load equal to the maximum rated load. This load should be applied to the power supply continuously. The power supply should be turned on (energized) under full load (characterized) conditions at the start of the temperature transition from low to high temperature; defined as the cold-start condition. The power supply should be turned off for no less than one minute, at least four times during the thermal cycle, i.e., twice when the chamber ambient is between low temperature and 0°C , and twice at high temperature after thermal stability has been reached. The input power should be applied and removed in an abrupt manner, as by a relay or mechanical switch. Except for such planned on/off cycling, the power supply should then be operated continuously until thermal stability is reached. During the transition from high to low temperature, the power supply should be turned off and remain de-energized

until the start of the transition from low to high temperature. The power supplies should be turned on at the end of the cold soak period of the thermal cycle. This provides the maximum thermal shock and stimulates the failure of weak components and elements. It has been observed that most failures occur during the transition, with power on, from low to high temperature. The power supply would not be expected to operate within its performance criteria until its temperature rises within that specified for power-on operating conditions by the customer specification. An example temperature cycling profile is provided in Figure 3.3-1.

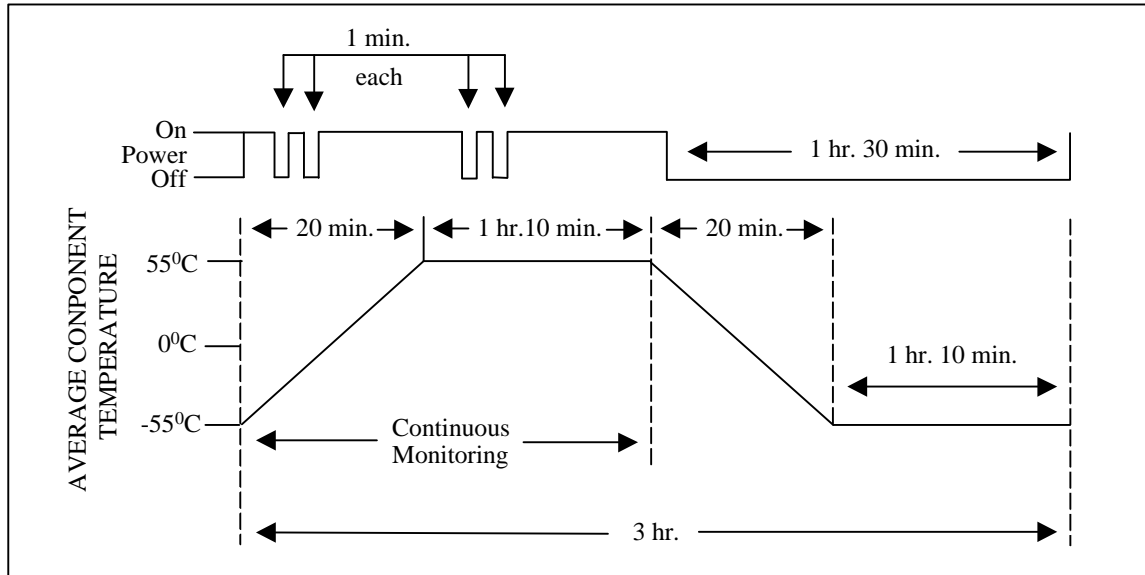

Figure 3.3-1. Temperature Cycle Profile Example

Tri-Service Technical Brief 002-93-08, Environmental Stress Screening Guidelines, should be used to develop and implement an optimum ESS program.

Highly Accelerated Stress Screening (HASS)

HASS is a form of ESS that can also be used to precipitate and detect manufacturing defects. HASS stress levels and profiles are normally determined using step stress testing (e.g., HALT) to ensure an effective non-destructive screen within the design limits.

3.3.3 Acceptance Testing

Acceptance testing must be designed to assure that the production units meet all the power supply specification performance requirements. Acceptance tests results should be documented for each unit. Failed power supplies must be repaired using the same processes and equipment used during manufacture and resubmitted to the acceptance testing process.

3.4 Standard Practices

Key points to consider when designing and evaluating a switching power supply:

- Incorporate voltage transient protection on the input power lines.
- Include a controllable soft-start circuit to relieve the component stresses during turn-on.
- Provide an internal housekeeping power supply to isolate sensitive circuits from the hostile power line, improve human safety and allow control of power-up and power-down cycles.
- Incorporate a crossover interlock circuit in the power stage that is connected across the power line so two devices can never conduct simultaneously across the power line.
- Incorporate input EMI filtering having characteristics compatible with the variable negative input resistance characteristics of the power supplies so that the combination is stable.
- Incorporate a fast-attack latching current limiting circuit to protect the power devices when the control logic fails intermittently due to random noise or other abnormal circumstances.
- Design the power inductors, transformers and magnetics to keep them out of saturation during peak load and transient conditions for worst-case core temperature.
- Sequence the turn-on/turn-off logic in an orderly and controllable manner.
- Analyze and measure worst-case peak currents, peak power, peak voltage and ripple currents in all devices and under all worst-case static and dynamic conditions and compare the measured results with the rated limits of all components.
- Perform worst-case thermal and hot-spot analyses.
- Design printed wiring boards and packaging for the best heat transfer.
- Plan the circuit so that it will not be subject to common-mode and/or differential-mode noise
- Circuit designers must be responsible for the electrical and printed wiring board layouts.
- Package magnetic devices and other heavy-current-carrying conductors with thermal interfaces adequate to meet hot-spot temperature requirements.
- Heat sinking should be provided for capacitors that have significant core temperature rise resulting from ripple currents.
- Capacitor heat removal is facilitated by form factors that exhibit large surface to volume ratios.
- Parallel capacitors must have provisions for ripple current sharing.
- Avoid ground loops and potential crosstalk and interaction by developing a grounding technique that is appropriate to the application.
- Analyze and measure loop stability to ensure that there is adequate phase and gain margin under all line, load, temperature and component tolerance variations.
- Measure torque values required, when thermally conductive plastic impregnated fiberglass isolators are used, to determine whether they are adequate for the thermal interface and will not cause any damage.
- Do not use transistors beyond the forward/reverse bias Safe Operating Area (SOA) limits adjusted for junction temperature under any transient condition.

- Use of a “snubber” or load-line control circuits is recommended. Increased reliability has been observed in power circuits where semiconductor load-line excursions are constrained to approach the static operating power limits.
- Components that have a shallow base are sensitive to ESD and transients.
- Well documented power supplies are usually well thought out and exhibit fewer latent design flaws. Power supply documentation should include performance specification, physical description with interfaces, functional block diagrams, all circuit schematics with theory of operation, magnetic and unique subassembly specifications and acceptance criteria, and thermal design data.
- The following requirements should be considered for power supply components:
 - assure that the supplier performs adequate electrical parametric testing to ensure component quality for the design application environment. Devices failing during HALT testing should be returned to the component manufacturer for failure analysis, corrective action and report of corrective action
 - maintain an approved vendor list relating to known component quality and performance. Note: Components of a given type may not perform the same electrically in a different application and thus may require a specification control drawing

For designing and evaluating modular power supplies, the following additional considerations apply.

- The interconnection of the high density modules generally requires common mode filtering to prevent coupling switching frequency noise to the input prime power source and other associated modules. Differential mode filtering is required to decouple the power supply from noise and modulation on the input power bus. If the power supply is to be integrated into a system where the conducted switching frequency noise modulates the output voltage, the system performance could be jeopardized. In this case, a constant conversion switching frequency, synchronized to a system clock, should be considered. This topology allows the designer to narrow band attenuate the switching frequency content on the output voltage, thus minimizing any affect of producing false signals within the weapons system.
- Ancillary features that are often standard on high density DC/DC converter modules include over-current/over-voltage protection, over-temperature inhibit, enable/inhibit output voltage control, remote sense, output voltage trimming, Built-In-Test and inter-parallel communication of similar modules to permit current sharing.
- EMC management, in compliance with either the FCC requirements or MIL-STD-461, may be accomplished through the use of available standard encapsulated filter modules. These modules are universally offered for interfacing with DC, single-phase, and three-phase prime input power. Shipboard power requires that the individual harmonic current content remain below 3%. Power Factor correction modules are available that provide power factor management; however, most do not provide prime power return isolation. These modules cannot be utilized for three-phase operation and special techniques should be applied when interfacing with ungrounded, single phase, 115 volt shipboard power. When selecting the power factor correction module, specific harmonic current test data should be obtained from the manufacturer to assure MIL-STD-1399 Section 300 compliance.

SECTION 3

- To enhance power system reliability, the DC/DC converter output modules may incorporate parallel diodes or'd in an N + M configuration. Monitoring the output voltage prior to the dedicated decoupling diode provides a cost effective means to determine the health of each DC/DC converter to indicate the need for maintenance. Each module within the power supply should incorporate a plug-in electrical interface. The mating surface of each module pin and associated socket should be gold plated to minimize corrosion during long term application in a tactical environment.
- Use of available high density modules results in minimizing the power supply development time since the effort is primarily focused on physical packaging and electrical interfaces. The selection of identical modules throughout a weapons system reduces the TOC when consideration is given to logistics support.
- Switching power supply circuits should be enclosed within a grounded conductive shield to prevent radiated EMI.

Section 4

High Voltage Power Supplies

4.0 Objective

Guidelines for designing, verifying and manufacturing reliable high voltage power supplies are provided in this section. The guidelines established in Section 3, Low Voltage Power Supplies, are also applicable to High Voltage power supplies

This section addresses characteristics unique to high voltage design, e.g., corona, insulating material stress and component stress. High voltage power supplies are subject to unique wear-out mechanisms not found in low voltage power supplies. Limitations are reviewed relative to the requirement for a mature, efficient and reliable design. Key factors necessary for developing high voltage power supplies are shown in Figure 4.0-1.

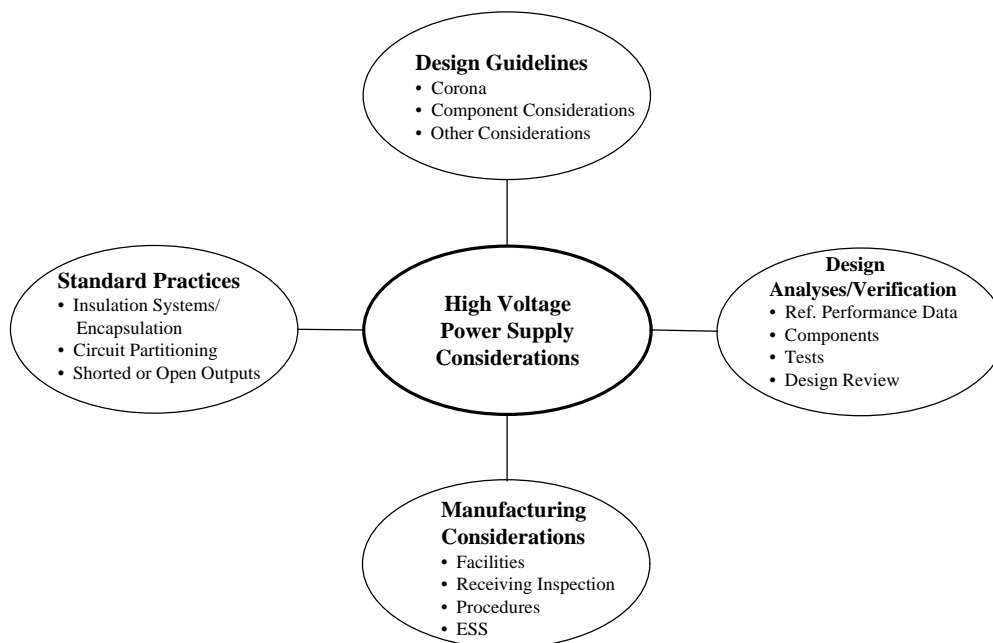

Figure 4.0-1. Key Factors for Developing Reliable High Voltage Power Supplies

4.1 Design Guidelines

Examples of the factors shown in Figure 4.0-1 are highlighted in the following subsections, providing insight into potential problems and the techniques that are applied to high voltage (i.e., above 300 volts) power supplies:

- 4.1.1 Corona
- 4.1.2 Component Considerations
- 4.1.3 Other Design Considerations

4.1.1 Corona

Corona discharge is a predominant cause of failure in high voltage power supplies since it results in degradation of the insulation system. Successful corona reduction commences with initial power supply design and continues through manufacturing. A key element involves controlling the internal geometry to maintain acceptable field strength throughout the power supply.

The terms Corona Discharge and Partial Discharge are generally used to describe electrical discharges that involve only a portion of the dielectric between two electrodes rather than bridging the electrodes. In all of these discharges, gas molecules are ionized by the impact of electrons. The liberated electrons gain speed in the electric field, ionizing more atoms by impact, so that an avalanche of electrons is formed. The electrons in the avalanche and the remaining ions move toward the electrodes, thus forming a passage of current through the insulation system. Although the energy dissipated with each discharge is small, these partial discharges can cause deterioration and ultimately, failure of the dielectric system.

Degradation caused by corona can be reduced by careful selection of materials. A self-healing dielectric would be desirable but difficult to achieve. Oil systems are somewhat tolerant to arcs as the degraded products become dispersed. However, the degradation is still cumulative. Where the system dielectric is a gas or vacuum, arcs or corona can cause damage between interconnects and between components. Vacuum components, such as traveling wave tubes, vacuum relays, vacuum capacitors, vacuum triodes and diodes, can withstand a number of internal arcs without failure. Corona in solid dielectric, which usually occurs at dielectric interfaces or voids, is cumulative and eventually results in catastrophic failure.

High Voltage Field Control

Corona is generated by high concentrations of the high voltage field, usually as a result of sharp points, small geometries and their associated spacing. The high voltage field is characterized by the "E" field gradient. The higher the number, the greater the risk. There is an adjunct coefficient called the "utilization factor" that acts as a multiplier to the gradient number and this utilization factor is dependent upon sharp edges and proximity. Optimum utilization factors, based on the minimum voltage stress condition, are obtained with a uniform voltage distribution across the insulating material. Corona inception and associated problems can be avoided by the following:

- Specified geometries should be consistent with the voltages contained within the power supply. A high voltage "E" field gradient analysis should be performed and validated to ensure that the appropriate utilization factors were used with the specific geometries.
- Component case and conductor shapes can create concentrated voltage fields and/or fracture planes. Component edges, corners and fasteners should have a radius or a fillet.
- Positioning of all components, connectors and cabling should be part of the design and verified throughout the assembly process.
- Conductors exiting from high voltage planes should not create concentrated voltage fields at the exit point.
- Where connections are made using soldering techniques, a minimum solder ball diameter should be specified and controlled.
- Avoid the use of multiple insulating materials.
- Minimize interfaces.
- Establish and enforce cleanliness procedures to prevent contamination.
- Use vacuum impregnation and pressure curing techniques to minimize voids in encapsulation materials.
- Prepare all surfaces for bonding using wet or dry plasma, or etching techniques and cleaning.
- Derate insulating materials based on maximum (not average) electrical stress.
- Pre-assign boundaries of high-field intensity and define voltage gradients.
- The voltage gradients within a resin system should be less than 50 VDC/mil. Across an interface between insulating materials, the gradient should be less than 25 VDC/mil. It is recommended that AC voltage gradients should be less than one-half of the DC gradient.
- The use of laminated insulating barriers and printed wiring boards should be avoided.
- Where the use of printed wiring boards cannot be avoided in high voltage fields, shielding or barriers should be added. Corona testing is mandatory to demonstrate the amount of design margin. The voltage gradient between conductors should be based on IPC-D-275.

4.1.2 Component Considerations

High voltage fields create unique material design problems which may affect long-term reliability. In addition to the normal design techniques used for low voltage components, high voltage applications require additional considerations. These include:

- special derating considerations,
- 100% verification of low corona levels (special corona detection equipment must be used),
- special tests while operating at high voltage to ensure proper geometry and spacing, and
- 100% burn-in of components at their expected operating voltage.

SECTION 4

Derating

High voltage component stress derating must be applied in a similar manner to low voltage components. Additionally, high voltage components are internally exposed to increased electric field stress. Reliable equipment requires at least a 1.5:1 margin and, more commonly, a 2:1 margin (800V/mil "rating" versus 400V/mil "operating") is used. The maintenance of low component temperatures is important to achieving extended life. Elevated temperatures degrade insulation, thereby reducing high voltage integrity.

Corona Detection

Knowledge and use of corona detection equipment is critical to verify component selection. The degrading effects of corona are greatly increased if significant levels of AC voltage exist. This problem becomes acute at higher frequencies. AC and DC Corona Inception Voltages (CIV) are the key characteristics to be monitored. Sensitive, specialized test equipment has been developed that allows measurement and control of corona at levels previously undetectable. Corona minimization can best be achieved by choosing the appropriate circuit configurations in order to minimize AC voltages applied to all components.

Magnetic Components Design

Magnetic components represent a major design effort for any high voltage power supply. Successful magnetic design approaches use proven guidelines, such as:

- the voltage gradient between any two adjacent wires in a winding should be minimized,
- a core that is electrically isolated should have an auxiliary lead brought out to facilitate hi-pot testing between the core and windings,
- windings may be encapsulated unless dielectric loss is a factor (Note: Encapsulation must be void free), and
- winding terminations to insulated lead wires should form a strong mechanical joint.

Vendor Selection

Vendor selection is a critical factor. Experience is not easily achieved in designing, producing, testing and screening high voltage rectifiers, capacitors and resistors. Stringent controls and attention must be applied to available manufacturing resources. High voltage components require special treatment in addition to that outlined in Section 3. This includes geometrical control, material selection, spacing, void control and other design criteria.

4.1.3 Other Design Considerations

High Voltage at High Altitude

Those working with high voltage power supplies for aircraft or spacecraft have recognized the relationship between breakdown voltage over some distance or gap, and ambient pressure. As ambient pressure decreases with voltage and distance remaining the same, the likelihood of a discharge increases. Paschen's Law, illustrated by curves in Figure 4.1-1, quantifies this relationship. Note that the effect varies depending upon the particular gas in the environment.

The best insulation system available is a very clean environment exposed to the hard vacuum of space.

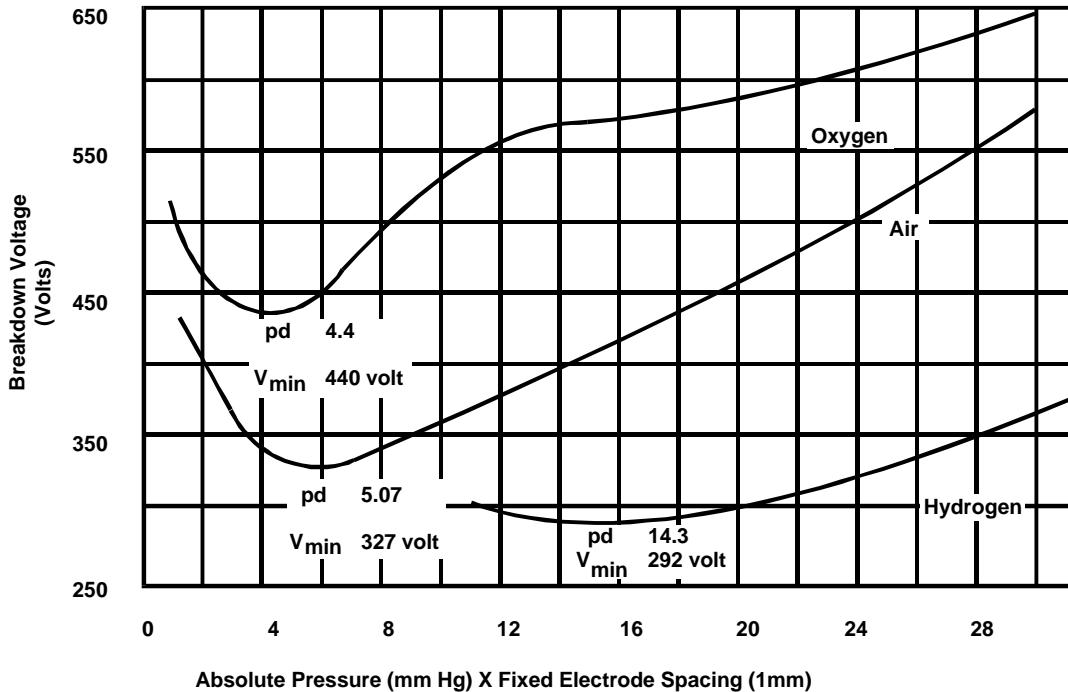

Figure 4.1-1. Paschen's Law Curves for Oxygen, Air, and Hydrogen with Electrode Spacing Fixed at 1mm

Paschen's Curves provide the relationship between the product of pressure (P) times electrode spacing (d) and the breakdown voltage normalized at one mm spacing. The "Pd product" is along the horizontal axis and is computed as the product of pressure, in mm Hg, and electrode spacing in mm. From the curves, air at 28 mm Hg and electrode spacing of one mm indicates a breakdown voltage of 550 volts (Pd product of 28). If the pressure is reduced to 14 mm Hg and the spacing increased to two mm, the Pd product remains the same, 28, and the predicted breakdown voltage remains at 550 volts. However, as the graph in Figure 4.1-2 indicates, there is a minimum at approximately Pd = 5.07. At Pd products below this "Paschen's minimum," breakdown voltage rises rapidly, quickly exceeding that at one atmosphere. As seen in Figure 4.1-2, the curve for air is near linear from Paschen's minimum to beyond Pd products of 15,000.

SECTION 4

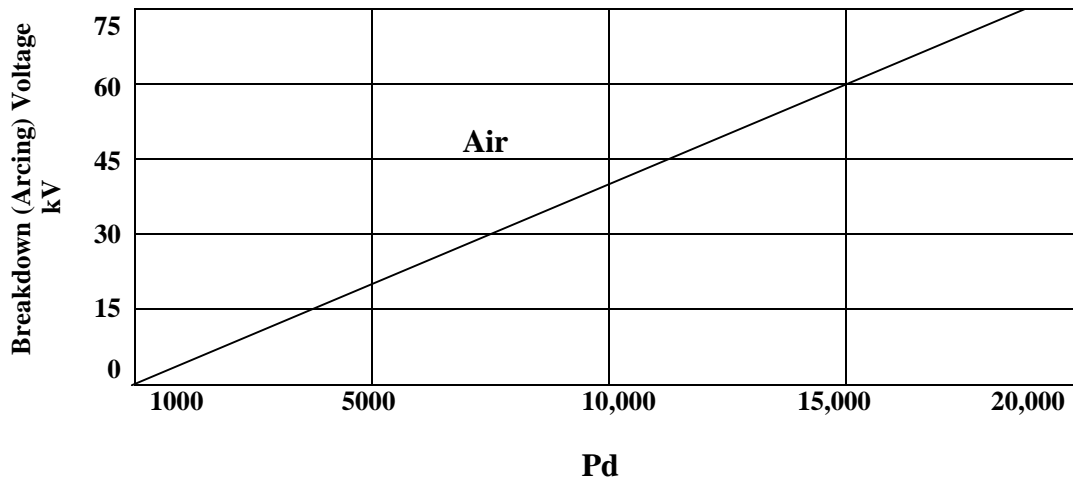

Figure 4.1-2. Paschen's Law Curve for Air with Electrode Spacing of 1mm

Arc Damage Prevention

The ability of a system to tolerate an occasional arc is an essential part of a viable, high voltage design. Circuit design and packaging techniques play a key role in the ability to tolerate an arc. Most designs will limit current available to an arc through inductive di/dt or resistive limiting combined with current sensors and rapid turnoff.

In high voltage systems, arc prevention is always a goal. However, unintended high voltage discharges are not unusual during the various phases of testing or high voltage power supply integration. With properly designed power supplies, any high voltage arc normally occurs in the load. The concern is to determine the exact path of the discharge current. The key to damage prevention rests with control of the arc current path.

The energy source is usually the output filter capacitor in the high voltage power supply. The most obvious approach to allow the current to return directly to the source is to provide a low impedance connection between the load return and the energy source return. This connection minimizes arc current flow in unknown paths through the ground system and possibly through sensitive, damage prone circuits as it seeks the energy source. An example of such a connection would be a coaxial high voltage cable. The shield provides a good low impedance return connection to the arc current source.

If a low impedance connection between load return and energy source return is not permitted, at least one other option remains for controlling the arc current path. The installation of two diodes connected in inverse parallel between the energy source return and the load return can provide the needed current path without connecting the two returns directly together. If greater isolation voltage is needed, more series connected diodes may be used to ensure that the diodes are not normally forward biased. If there is an arc, the diodes then conduct, providing the return current path. The diodes also must be sized to handle the surge current resulting from an arc.

Physical Design

Mechanical packaging of high voltage power supplies directly impacts its reliability. The failure mechanisms that must be prevented by proper mechanical design are insulation breakdown, thermal stress and mechanical failure such as cracking. The size and shape of the power supply must be adequate for sufficient derating of the insulation system.

4.2 Design Analyses/Verification

In addition to the low voltage power supply guidelines in Section 3, there are additional design analyses and verification considerations for high voltage power supplies. Since the design analysis guidelines in Section 3 are fairly complete with respect to high voltage power supply requirements, this section will emphasize design verification procedures. Similar to low voltage power supplies, verification of high voltage power supply design maturity is accomplished by means of appropriate testing. Guidelines are presented in the following subsections:

- 4.2.1 Reference Performance Data
- 4.2.2 Components
- 4.2.3 High Voltage Power Supply Tests
- 4.2.4 Design Review Checklist

High voltage power supply testing is similar to low voltage power supply testing, but several differences must be considered. The selection of high voltage insulation requires verification of mechanical, electrical and thermal design margins. Development testing of pre-production units during the design phase is necessary to uncover inherent design and manufacturing defects before designs are committed to production. Lack of uniformity in specifying and screening high voltage components has contributed to significant reliability problems in many programs.

In addition to the procedures in Section 3, the following sequential design verification procedures for magnetic devices should yield a proven magnetic device design.

1. Fabricate several devices utilizing production processes
2. Perform parametric tests
3. Perform corona test (AC and DC CIV)
4. X-ray
5. Perform thermal shock per MIL-PRF-27
6. Perform corona test (AC and DC CIV)
7. X-ray
8. Perform parametric tests

SECTION 4

4.2.1 Reference Performance Data

To ensure the integrity of high voltage power supplies used in design verification testing, a database should be established and maintained for reference throughout the testing phase, and contain the following information:

- Results of receiving inspection test on all high voltage components
- Results of all subassembly tests
- Results of the Manufacturing Test Procedure
- Results of the Acceptance Test Procedure
- Records of all failures and corrective actions
- Records of environmental stress screening
- Records of all quality conformance inspections
- Records of all serial numbers and manufacturing lot numbers

This database will be useful in the identification of design problems, the analysis of trends, and the implementation of corrective actions.

4.2.2 Components

Components must be thoroughly evaluated to ensure that they meet required reliability requirements and that all materials used in the fabrication of the devices are compatible with the overall system. These evaluations include:

- Surface bondability
- Control of contamination
- Corona Inception Voltage (CIV)
- Leakage current
- Electrical characteristics
- Temperature cycling/shock
- Adhesion

4.2.3 High Voltage Power Supply Tests

Design Verification and In-Process Tests

The following design verification tests should be performed:

- Corona level
- Leakage current
- Operation under worst case conditions
- Temperature cycling/shock
- Arc tolerance

If the high voltage power supply is designed such that the electrical field stress exceeds the CIV of air, a temporary insulation, using either gas or a liquid, must be used when performing in-process tests. Materials that can be used for this type of test include sulfur hexafluoride gas or fluorocarbon liquids. Requirements for liquids or gases used during testing are as follows:

- Do not contaminate surfaces or leave films.
- Ensure compatibility with the materials used in the power supply.
- Do not produce ionic contamination under normally expected discharge levels.
- Include a high dielectric strength.
- Ensure easy and complete removal after testing by heating or vacuum drying.

Insulation System Tests

Tests commonly used to evaluate high voltage devices include dielectric strength and over-voltage tests. Unfortunately, these tests may cause damage to the insulation system due to overstress. Such damage may remain undetected and reduce the life of the system. Any high voltage test performed should provide a quantitative indication of the quality of the insulation system. Corona and leakage-current tests can provide data as well as a basis for a continued verification of the insulation quality.

Dielectric breakdown and corona are the two prevalent failure modes in high voltage devices. In solid, encapsulated devices, corona often occurs at only a fraction of the material breakdown voltage due to the presence of voids in the insulation. There are two general categories of voids. One is introduced in the insulation during the manufacturing process, and the other is realized after encapsulation due to stresses such as cracking or loss of adhesion at an interface. To detect both types of voids, it is necessary to subject the insulation system to temperature cycling and perform a corona test before and after this cycling. Any increase in the corona level after temperature cycling indicates cracking and/or separation of the potting materials. Cracking in potted modules should be verified by real-time X-ray inspection followed by dissection for further analysis. The data must be carefully analyzed and limits must be established on the allowable changes in high voltage characteristics.

Corona Inception Voltage Tests

The most meaningful measure of insulation integrity is the AC voltage at which significant, sustained partial discharges (or corona) occur, referred to as the Corona Inception Voltage. In all cases, the CIV should be greater than the operating voltage. Repeatable, distinct corona activity can be seen in most insulating media at AC voltages considerably lower than in the DC case. Voids, fractures, separations, delaminations and other defects can be observed with AC testing which is not possible using any other method. Several manufacturers of partial discharge test equipment have been successful at detecting low-level corona (in the order of 0.1 to 1 picocoulomb (pC)) with practical, cost-effective equipment. The more successful high voltage designers and manufacturers have used this equipment to:

- understand basic corona phenomena,
- compare different types of materials, components, subassemblies, processing, etc., and

SECTION 4

- provide a consistent screening tool for research and development, production and "health" checks of finished components and equipment.

Detailed procedures can and should be developed for the various required tests and evaluations. There is considerable variation in the sensitivity of various corona test sets due to inherent noise in the equipment and the method of corona pulse detection. Where an oscilloscope is used for the display of corona pulses, only an approximate CIV can be measured. Test equipment, that applies pulse height analyzers in conjunction with a computer, can give a definite measure of the corona intensity, expressed in picocoulombs per second when averaged over a specified period. Both AC and DC corona inception test voltages should be specified from 25% to 100% above the working voltage. Since the corona intensity increases exponentially with increasing applied voltage, the intensity at the working voltage will be much less than the established limit (1 to 5 pC) and, for practical purposes, the component or system is "corona free." A generally used procedure is as follows:

1. The device is placed in the test setup and a simulation of a corona pulse is introduced into the sample to allow accurate calibration of the system's detection and display apparatus.
2. The applied 60 Hz AC voltage is slowly increased until significant corona activity is seen. (For most test equipment, 50 pC is the typical threshold of inception. With filtering and operating in a shielded room, the test equipment can reliably detect considerably smaller inception values; i.e., in the 1 to 10 pC region.)
3. The test is then repeated at least once, and if the value correlates with the initial value, the inception voltage is thus recorded. The Corona Extinction Voltage (CEV), i.e., the AC voltage whereby the observed corona extinguishes, is also measured and recorded.
4. The above test, simple in concept and very easy to perform, is repeated as necessary to allow periodic checks of the insulating media, e.g., CIV levels at different processing points (or with differing materials) can be used to identify voids, cracks, delaminations, and other defects.

Thermal Survey

High voltage power supplies present a special problem in preparation for a thermal survey. Thermocouples embedded in magnetic devices and/or high voltage sections can cause arcs or conduct leakage currents which create measurement errors and safety hazards. The following cautions should be observed:

- When thermal measurements must be made in a high voltage field, use analysis or measurement techniques that do not require a thermocouple in the high voltage field.
- When thermocouples are used, place isolation devices between the thermocouple bead and the point to be monitored to ensure safety for the operator and equipment. Use isolation devices which do not degrade the accuracy of thermal measurements.
- Provide shields and/or bleeder resistors to prevent leakage-current paths through thermocouples.
- When safety of the operator or accuracy of the measurement is in question, use automated equipment and discontinue operation of the high voltage for short periods of time to allow data collection.

- When units modified for thermal survey are to be used in further testing or in systems, ensure that all external connections to embedded thermocouples are removed and/or permanently sealed off from external access.
- Minimize the number of thermocouples placed within the high voltage section.
- Ensure that routing of thermocouples in the high voltage field does not violate the design criteria for voltage stress.

Environmental Testing

Environmental testing of high voltage power supplies will follow the same guidelines as required for low voltage power supplies. In addition to pressure vessel/explosion testing and leak testing (if pressurized), arc resistance testing of high voltage power supplies is required. This ensures that the circuit design and components selected can withstand arcs from each output to all other outputs and ground, as well as short circuits to ground, without degradation. These tests verify the arc resistance of the electrical and mechanical designs and should be performed at ambient conditions, at temperature extremes, and with input line and load perturbations applied.

4.2.4 Design Review Checklist

The sample checklist in Appendix B should be used as a baseline for high voltage power supply design reviews.

4.3 Manufacturing Considerations

Five necessary ingredients to sustain reliability during manufacturing of high voltage power supplies are:

- 4.3.1 Dedicated Facilities
- 4.3.2 Receiving Test and Inspection
- 4.3.3 Detailed Procedures
- 4.3.4 Environmental Stress Screening
- 4.3.5 Personnel Training

4.3.1 Dedicated Facilities

A typical facility for solid encapsulant fabrication and test should be a clean, controlled-access area. This will prevent unwarranted traffic through the area and prevent contamination by untrained personnel. Contamination can cause many failures in a high voltage power supply even though the best materials and components are applied. The controlled area should contain the following:

- Receiving inspection
- Storeroom
- Necessary workstations

SECTION 4

- Inspection station
- Segregated encapsulating equipment for epoxy and silicones
- Test facilities for:
 - Corona testing
 - Component testing
 - Subassembly testing
 - Top assembly testing

All personnel working in this area should be required to wear white cotton, lint-free gloves. If assemblies have ESD sensitive components, they should be handled at an ESD workstation, which meets the guidelines of MIL-STD-1686. However, human safety and high voltage handling procedures must take precedence over ESD procedures. The following areas are critical and should be designed to prevent contamination of other areas.

- Abrasive Cleaning - The abrasive cleaning area should be sealed and vented to an outside area.
- Encapsulation Rooms - Segregated encapsulating equipment is required for epoxies and silicone rubber to eliminate cross-contamination. Vacuum pump exhausts should be filtered and routed outside the area. The oven used for curing the insulation systems should be treated the same as the vacuum pumps. The encapsulation system should be a vacuum-transfer system with pressure-curing capability.
- Cleaning Station - The cleaning station should consist of an environmentally acceptable vapor degreaser, with spray attachment and other cleaning aids, such as cleaning brushes, disposable lint-free tissues and a vacuum drying oven for dry cleaning and removing unwanted moisture.

4.3.2 Receiving Test and Inspection

The receiving inspection area should have access to equipment for 100% testing of all high voltage components and be capable of performing burn-in tests. Each class of component should be tested as follows:

- Capacitors
 - Corona
 - Arc discharge current
 - Parameters
- Resistors
 - Stability at rated voltage
 - High peak current if used for current limiting
 - Parameters
 - Corona
- Magnetic Components
 - Corona
 - Insulation

- Parameters
- Insulating materials as required per specification
- Other components and subassemblies as required to meet the power supply specification

The purpose of the receiving test and inspection is to ensure acceptability of all components used in the assembly of high voltage power supplies. The tests are planned to eliminate premature failure and thus reduce rework time required for the repair of failed units.

4.3.3 Detailed Procedures

Insulating material

Insulating material specifications and test procedures are required to ensure that the received material conforms to the requirements, including the verification of the expiration date.

Contaminated material that is received and not tested at this point in the manufacturing cycle may cause a subsequent failure.

Vacuum Encapsulation

As required, vacuum encapsulation procedures should be detailed as to mixing ratio, time under vacuum, vacuum level, pot life, cure time, temperature and pressure. Some insulation systems create gas bubbles during curing. Curing under pressure will drive the gases back into the solution, thus allowing them to cure as a solid. The use of a ratio dispensing system is a preferred method of dispensing compounds. This system eliminates operator error and prevents contamination of materials. Power mixing is preferred to hand mixing, and when properly used, produces a superior mixture. Records of mixed batches and control samples should be preserved.

Cleaning

The following cleaning procedures are the most critical in the high voltage assembly area:

- White cotton lint free gloves should be worn at all times to ensure that the assemblies are not contaminated with fingerprints.
- As required, the first operation to be performed on all components is abrasive cleaning. Abrasive cleaning procedures should specify the type of equipment and abrasive material. The abrasive material should remove any gloss or contamination that is on the components. Engineering drawings should specify which components require abrasive cleaning.
- The second operation to be performed on all components is chemical cleaning before starting assembly operations. As the assemblies are fabricated, it may be impossible to clean some of the components.
- Cleaning should be performed to remove solder fluxes.
- All cleaning agents should be monitored to ensure that they are not contaminated.
- Finished assemblies that are not going to be immediately encapsulated should be stored in containers after final cleaning. The container should be filled with dry nitrogen if extended storage is required.

SECTION 4

4.3.4 Environmental Stress Screening

High voltage power supplies should be subjected to ESS as described in Section 3 and as follows:

- Following random vibration and 100% parametric testing and prior to temperature cycling, an altitude test should be conducted and monitored continuously during the following conditions:
 - 4 hours at altitude and minimum system operating temperature
 - 4 hours at altitude and maximum operating temperature
 - 100% parametric testing per the customer's Acceptance Test Procedure
 - all subassemblies shipped as spares should receive the same ESS as those subassemblies procured as a part of a complete final assembly

4.3.5 Personnel Training

Personnel assigned to work in the high voltage assembly area should receive training to ensure compliance with all procedures. This training should include classroom as well as on-the-job training. Supervisors, assemblers, quality assurance, storeroom and test personnel should complete this training. The purpose is to achieve a well-trained, highly motivated, and efficient work force dedicated to doing a quality job. Safety problems may be encountered when testing requires proximity to high voltage. Additional factors must be addressed and include, but are not limited to, potential fire and explosion dangers.

4.4 Standard Practices

The following standard practices are key considerations when designing high voltage power supplies.

- 4.4.1 Insulation Systems/Encapsulation
- 4.4.2 Circuit Partitioning
- 4.4.3 Shorted or Open Outputs

4.4.1 Insulation Systems/Encapsulation

The system dielectric can be defined as the material(s) that provides electrical isolation between components and structural elements of the high voltage power supply. Dielectric systems can consist of solids, liquids or gases depending on the application. A summary of their major advantages and disadvantages is presented in Table 4.4-1. Selection of a dielectric system for a specific application is beyond the scope of this document.

Table 4.4-1. Characteristics of Insulation Systems

Materials	Advantages	Disadvantages
Solids	Good heat path Good mechanical support	Poor corona resistance Poor internal arc resistance Processing and controls critical Subject to stress cracking
Liquids	Recovery from arcs possible	Complex container required including volumetric compensation Pump required for heat removal Component support required
Gases	Potentially lower weight Recovery from arcs possible	Complex container required Highest volume required Poor heat path Component support needed

All insulating materials used in the fabrication of high voltage power supplies should be inspected in accordance with the applicable material specifications. Contamination control should be a high priority with all insulation systems. Table 4.4-2 summarizes those tests that should be performed as a part of the design verification testing for the selected insulation system.

Table 4.4-2. Insulation Material Tests

Tests	Insulation System Requirements		
	Solid	Liquid	Gas
Tensile Strength	Yes	No	No
Hardness	Yes	No	No
Coefficient of Expansion	Yes	Yes	No
Thermal Conductivity	Yes	Yes	Yes
Dielectric Strength	Yes	Yes	Yes
Volume Resistivity	Yes	Yes	Yes
Dielectric Constant	Yes	Yes	Yes
Dissipation Factor	Yes	Yes	Yes
Arc Resistance	Yes	Yes	Yes
Glass Transition Temperature	Yes	No	No
Adhesion	Yes	No	No
Flash Point	No	Yes	Yes
Vapor Pressure	No	Yes	No
Reversion Resistance	Yes	No	No
Pour Point	No	Yes	No

SECTION 4

Encapsulation of high voltage assemblies provides mechanical stability, protection against contamination, and excellent high voltage insulation. The decision to encapsulate involves selection of encapsulating materials and processes. The materials decision relates to the materials to be encapsulated and the temperature extremes to which the final product will be subjected. In particular, ceramic or glass components and hard epoxy encapsulant can be an incompatible combination. Considering that the adhesion between the encapsulant and the ceramic (or other) components is significant, just the shrinkage of epoxy during cure can mechanically stress or fracture the potted components. In addition, the relatively large Thermal Coefficient of Expansion (TCE) difference between the two, combined with the great adhesion, can easily cause fractures during temperature cycling. Note that both high and low temperatures can cause mechanical stress.

Mechanical stress problems during temperature cycling can be minimized by use of a more compliant material, such as urethane, or by the addition of glass filler material to alter the TCE of the final batch. Urethane is a softer, more compliant material that is unlikely to exert damaging forces on the encapsulated components, although its TCE is significantly greater than that of ceramic. Filling the urethane material with glass moves the TCE much closer to that of ceramic, minimizing the TCE incompatibility problem. There are many choices of material beyond those mentioned. Materials to be avoided include any that exhibit a glass transition temperature within the expected operating or test temperature range of the encapsulated assembly.

In any encapsulated assembly, voids in the material are the single largest problem. A void is a cavity in the material containing a gas. If the pressure is high, one atmosphere for example, corona initiation is less likely. However, in low-pressure applications, the gas pressure may leak down over time until the pressure and void dimensions reach the critical pressure-distance product resulting in corona discharge within the void. Over time, corona within voids in potting results in destruction of the material.

The problem of voids in potting can be addressed by using a vacuum chamber. At a minimum, the encapsulant can be placed under vacuum before pouring to remove trapped air. Alternately, after the pour, but before the material sets, the encapsulated assembly can be placed under vacuum to remove trapped air. Both of these techniques produce marginal results. A far better approach to the problem is to pour while the assembly is under vacuum. An additional step, increasing the chance of success, is allowing the encapsulant to cure under pressure. This technique assures that any voids, unlikely if proper care is taken in previous steps, are compressed in size.

One interesting alternative to encapsulation is the use of Paraxylene coating, a material normally used as conformal coating in specialized applications. Since it is applied using vacuum deposition, Paraxylene coating assures a void-free environment for the coated components. This attribute, along with the high dielectric strength of the material, greater than 5,000 volts per mil, makes it an excellent choice in many high voltage applications. In applications requiring low mass, e.g., high voltage power supplies for space, Paraxylene is a very attractive choice.

4.4.2 Circuit Partitioning

In circuit partitioning, the following should be observed:

- The high voltage power section should be isolated from low voltage areas.
- Digital latching circuits should be isolated from the high voltage section with a different ground layer being utilized.
- Electrical interconnections should be minimized to prevent transient generation and propagation.
- Consideration must be given to the placement of noise sources and potential coupling through the stray capacitance of the insulation system.

4.4.3 Shorted or Open Outputs

Conservative design practice dictates that the output should be capable of surviving a shorted or open output, without degradation, for an indefinite time.

Section 5

AC Output Power Supplies - Inverters, Frequency Changers and Uninterruptible Power Supplies

5.0 Objective

This section addresses the unique features of electronic ac-output sources. Since the electronic operating principles of AC Output power supplies are similar to their DC counterparts, this section will concentrate only on issues unique to Inverters, Frequency Changers, and AC Uninterruptible Power Supplies (UPS). The design, verification and manufacturing considerations presented in this section are intended to be used as a supplement to the Section 3 guidelines for defining requirements and/or assessing capabilities of electronic AC output sources.

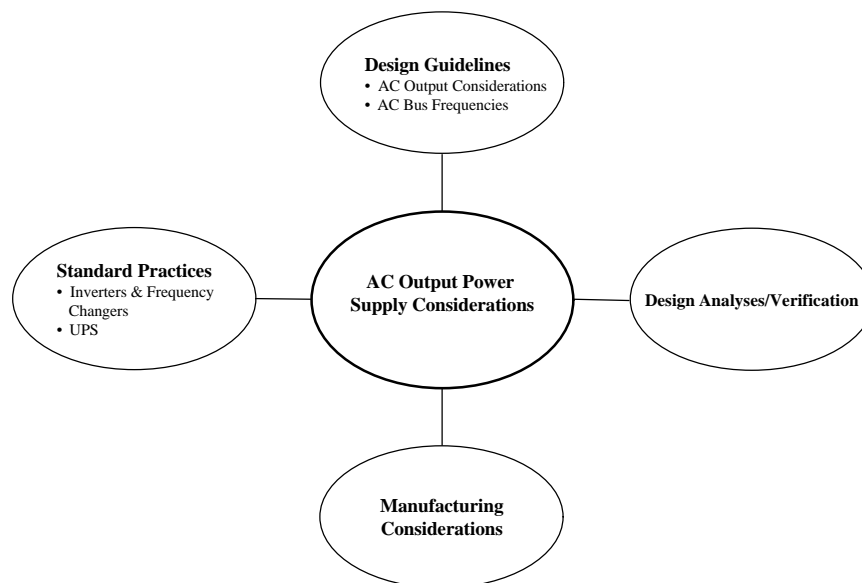

Figure 5.1-1. Key Factors for Developing Reliable AC Output Power Supplies

5.1 Design Guidelines

5.1.1 AC Output Considerations

The diverse nature of AC loads demands careful characterization of the power source requirements. A statement that simply references MIL-STD-1399/MIL-STD-704 interface requirements is often not sufficient. AC power requirements including output configuration, voltage, frequency, and power quality should also be carefully examined.

Output Power Requirements

To define adequately the output power requirements, the following parameters, as a minimum are needed because of the complexity of AC power:

Real and Apparent Power - The differences between these numerical values exists because voltage and current waveforms in AC circuits are not necessarily identical in shape and phase. The Real and Apparent powers are the same only with a purely resistive load. All other AC loads contain either non-linear or reactive components that increase the apparent power.

- The non-linear component introduces harmonics to the load current waveshape. These harmonics do not create useful output power, but increase the RMS value of the output current. These harmonics also interact with impedances in the distribution system, resulting in distortion of the voltage waveshape.
- Reactive current is introduced by linear reactive components. Reactive current circulates within the power distribution system, contributing to losses in, and heating of, cables and connectors. Where multiple AC output power sources are connected in parallel, the presence of circulating reactive currents may cause unequal load sharing.

Crest Factor - The Crest Factor is useful in ascertaining the ability of the AC Source to power the non-linear rectified capacitor loads, since these loads draw high peak currents. As a guideline, AC sources with a Crest Factor capacity above 2.5 are generally adequate to support end-user equipment.

Power Factor - Power Factor is the ratio of Real load power to the Apparent load power. Most commonly, this parameter is used to identify the ability of the AC Source to power reactive loads. The reactive power capability often complicates the design. Therefore, in attempts to lower product cost, many manufacturers do not offer this capability. Ensure that the reactive power requirement is specified if the load is expected to have a reactive component.

Non-Unity Power Factor - Power distribution systems are also sensitive to the effects of non-unity power factor, because the presence of reactive line current decreases the real power capability of most generators and alternators. Therefore, it is common to constrain the allowable range of power factors that an AC source may present to the prime power source.

5.1.2 AC Bus Frequencies

The standard AC bus frequencies are 50, 60, and 400 Hz. The output frequency usually carries no impact on the size and weight of the Pulse Width Modulated Inverters. In contrast, the size and weight of the Fundamental Frequency Inverter topologies (Squarewave, Resonant, and Harmonic Elimination) are heavily impacted by the output frequency. A 50 Hz Fundamental Frequency Inverter will normally weigh up to 7 times more than a 400 Hz inverter with an identical power rating.

Most end-user equipment is designed to tolerate moderate frequency variations, but some products are designed to rely on the accuracy of the output frequency. For critical applications, frequency stability and accuracy should be specified.

5.2 Design Analyses/Verification

As a minimum, the following design parameters should be verified:

- RMS Output Voltage (L-N) or (L-L)
- Initial Setting Accuracy
- Load and Input Line Regulation
- Time and Temperature Stability
- Frequency Stability and Accuracy
- Harmonic Distortion
- Noise
- Output VAR and Power Ratings

5.3 Manufacturing Considerations

Manufacturing considerations are identical to those of low voltage power supplies, which are delineated in Section 3.

5.4 Standard Practices

The following standard practices apply to Inverters, Frequency Changers, and UPSs:

- 5.4.1 Common Practice for Inverters and Frequency Changers
- 5.4.2 Common Practice for UPS

SECTION 5

5.4.1 Common Practice for Inverters and Frequency Changers

The most common configurations of AC outputs are:

Single Phase	2-Wire
Three Phase Delta	3-Wire
Open Delta	3-Wire
Three Phase Wye	3-Wire or 4-Wire

Symmetrical or non-symmetrical ground connections may be specified in all of the above configurations.

Parallel Operation and Circulating Currents (Phasor Relationships) - Some ac-output power supplies are designed for parallel operation. To avoid degrading the reliability of the system, parallel operation should only be used under two conditions. One occurs when the system loads exceed the power capability of a single power supply. The other occurs when critical loads cannot tolerate the power loss that would occur during the time required to transfer loads between sources in the event of a source failure. When AC power supplies are operated in parallel, there are several critical operational issues to be addressed:

- The frequency of operation of the sources must be synchronized.
- The output phase of each source must self-adjust to ensure equal sharing of the real component of load power.
- The output voltage of each source must self-adjust to minimize reactive currents that would otherwise circulate among the parallel outputs.
- Master/slave configurations, in which one supply assumes the role of master, should be avoided.

Total Harmonic Distortion (THD) - THD is used to describe the purity of the output voltage. It is defined as the ratio of all parasitic harmonics present on the output to the fundamental harmonic. Some requirements may limit the individual harmonics.

DC Offset - Some AC power supply outputs contain a DC voltage component. Excessive DC components may be harmful to the equipment powered by the AC output power supplies. Maintaining the DC content of the AC output under 0.05% of the output RMS voltage is recommended.

Output Ripple and Noise - Similar to DC power supplies, the output of the AC output power supply contains high-frequency ripple and noise induced by internal conversion. Several publications provide guidance for specifying limits for these parameters. For ripple content and for noise, the appropriate sections of MIL-STD-704, MIL-STD-461 and MIL-STD-1399 Section 300 should be applied.

Paralleling and Redundancy - Some AC output power supplies are designed for parallel operation. Similar to their DC counterparts, current sharing is achieved through droop share or via forced regulation techniques. However, in contrast to DC, the outputs cannot be steered through a diode for "seamless" fault isolation. Relay cut-off or semiconductor switches are employed to disconnect the faulty module. Other considerations include:

- The activation of the disconnecting devices is time-finite, therefore the fault disconnect delay will be seen on the output. The resulting delay may be tolerable in some applications. Since the AC output crosses zero two times per period, most equipment operating from an AC source will not be affected by this momentary interruption.
- The specification for a redundant AC power system should state the maximum allowable interruption due to a single module fault. IEEE STD 446 provides a good reference for a typical tolerance envelope acceptable by end user equipment.
- To ensure complete redundancy, the redundant AC output power supply must be examined for single-point failure modes. AC output power supplies operating in master-slave configuration are vulnerable to the failure of the master module. Systems regulated by a main controller are susceptible to shutdown in the event of the controller failure.

Output Protection - The output of the AC power source must be protected from the effects of shorted loads. Relying upon load-side breakers to isolate a faulted load requires that the AC source be capable of supplying as much as 300% of its rated current to ensure tripping the breakers. This can greatly increase the cost and complexity of the source's output stages. Furthermore, where a single source feeds multiple loads, or where multiple sources are connected in parallel, this approach can lead to hazards to equipment and personnel resulting from currents in excess of cable and load device ratings. For example, three AC sources connected in parallel can provide up to 900% of their rated current to a single faulted load, which could be well in excess of the capacity of the wiring to that load. The preferred approach is to use a load-side circuit breaker equipped with an under-voltage or remote trip coil and allow the AC source to trip the breaker open should the load current exceed the source rating.

Regenerative Load and Backfeeding - Some AC loads have the capacity to pump energy back into the power supply. These loads are primarily motor drives or the output of another AC source connected in parallel. This scenario is often present in parallel systems or during a slow bypass transfer. Since it is not easy to either return the backfeed energy to the input power source or to dissipate it internally, most AC output power supplies provide shutdown protection against this phenomenon. If backfeeding occurrences are expected, the ability of the AC power supply to operate reliably under these conditions must be specified.

External Filter Resonance - The harmonic content on the AC output may create undesired effects when an external filter is used. Typically, commercial filters are designed to perform at the rated fundamental frequency. The filter impedance is rarely specified for harmonic behavior. An external filter may contain circuitry that resonates at frequencies coincident with any harmonic on the AC output thus amplifying the distortion. High resonant harmonic content may cause excessive stress, audible noise, and potentially unsafe voltage levels on filter output. If the

SECTION 5

system design requires an external filter, the specification should include the necessary characteristics.

Fundamental Frequency Input Current Ripple Reflection - AC output power supplies deliver time-varying periodic output power. The periodic power variation is reflected on the input for supplies using DC input power. For example, a single-phase DC/AC inverter supplying 60 Hz output will draw a 120Hz component from its input DC source. Some AC output power supply designs have the capacity to attenuate the reflected component from the input by supplying an internal energy storage. If the AC content on the source lines is problematic to system operation, the specification should include the limitation for maximum allowed harmonic frequency content reflected to the input.

Inrush Current Support - An inverter may be required to power a load with a large inrush current. The inrush presents two potential dangers to the system: non-linear latch-up and multiple load reset. Both phenomena are related to the current limit characteristics of the AC power source. The non-linear latch-up is similar in principle to load recovery in DC power supplies. An unfavorable current limit foldback may prevent the power supply from recovering after an overload. AC loads, such as compressor motors, will draw up to 500% of the rated current for several seconds at start, thus presenting an opportunity for latch-up. Locked rotor machines can draw even higher current. The inverter must be capable of supporting this load and this requirement must be specified. A multiple load reset may occur when the AC source is powering critical equipment as the load with large inrush demand is introduced. Large inrush results in output foldback and starves the critical equipment.

5.4.2 Common Practice for UPS

Uninterruptible AC output power supplies should include the following additional requirements that are unique to this type of equipment:

Hold-Up Time - During input power interruptions, the UPS derives its power from an energy storage device. Hold-Up time is the parameter that specifies the UPS capacity to sustain load with no input power present. Hold-Up time is directly related to the capacity of the storage device. Therefore, by varying the storage capacity, UPS systems may be configured to support power interruptions ranging between milliseconds and hundreds of hours.

Most energy storage devices are extremely environment-sensitive. For example, the capacity of some batteries falls below 10% in temperatures under -20°C, and effects of aging and frequent power cycling are almost as pronounced. Therefore, specifications for Hold-Up time should include:

- Hold-Up Time as a function of load,
- operating temperature range,
- expected frequency of power interruptions, and
- life expectancy or battery replacement requirements.

Recharge Time - An UPS returns to normal operation when the input power is restored. In anticipation of the next power outage, the depleted energy must be replenished. The period required to return the storage element to 90% of its full capacity is defined as the Recharge Time. Recharge times normally vary between 30 minutes and 36 hours as a function of Hold-Up capacity and UPS architecture. Shorter recharge ratings are usually more costly. Conversely, longer recharge times impose the risk of mission failure if a subsequent power interruption occurs before the storage devices are recharged.

Transfer Time - This requirement applies primarily to stand-by UPS configurations, i.e., the backup power supply remains idle until a failure of the primary AC Source is detected and addressed. Transfer time is the delay between the primary source failure and the backup engagement. Commercially, these times typically vary from 1 to 100 milliseconds. Transfer time requirements below 5 - 10 milliseconds become a severe cost driver.

APPENDIX A

Sample Power Supply Performance Specification Checklist

DC Power Supply Performance Specification

Note: Specify the applicable specifications or standards in the areas indicated in the checklist below.

1. INPUT PARAMETERS

- a. Single Phase ____, Grounded, Y/N____
Three Phase ____, Delta__ Wye____, Grounded Neutral?____
DC____
- b. Prime Power Frequency _____Hz, ____(+)% , ____(-)%
- c. Input Voltage _____V Nominal, ____L-L, ____L-N ____(+)% , ____(-)%
- d. Voltage Transients____(+V, ____ msec, ____(-)V, ____msec
- e. Phase Voltage Unbalance: ____(+)% , ____(-)%
- f. Allowable Unbalanced Phase Current _____A
- g. Under Voltage Protection, Inhibited Below _____Vrms/DC
- h. Reverse Polarity Protection, with a prime power equivalent source impedance of 1%, ____Y/N
- i. Maximum Allowable Inrush Current, with an equivalent source impedance of 1% _____ A, for ____msec
- j. Power Factor @ Rated Load_____
- k. Efficiency @ Rated Load and Nominal Input Voltage _____%
- l. Applicable Specifications _____
- m. Differential voltage between AC return and chassis ground ____volts peak
- n. Input Current Harmonic Content____% of rated current vs frequency
- o. Input impedance ____ Ω , ____L-L, ____L-N, (Magnitude and phase vs frequency for minimum and maximum loads)
- p. Impedance unbalance _____%

APPENDIX A

2. OUTPUT VOLTAGE(S)

- a. Nominal ____ V, ____ V, ____ V, ____ V
- b. Set Point Tolerance as Related to the Nominal Output Voltage ____(+/-)%, ____(+/-)%, ____(+/-)% ____(+/-)%
- c. Adjustment Range (+/-)____ V, (+/-)____ V, (+/-)____ V, (+/-)____ V
- d. Adjustability Resolution ____(+/-)%, ____(+/-)%, ____(+/-)%, ____(+/-)%
- e. Remote Sense ____ Y/N, ____ Y/N, ____ Y/N, ____ Y/N
- f. Total Distribution Loss ____ V, ____ V, ____ V, ____ V
- g. Define Remote Programming ____

3. OUTPUT CURRENT(S)

- a. Minimum Load ____ A, ____ A, ____ A, ____ A
- b. Rated Current ____ A, ____ A, ____ A, ____ A
- c. Duty Cycle ____%, ____%, ____%, ____%
- d. Paralleled Outputs ____ Y/N, ____ Y/N, ____ Y/N, ____ Y/N
- e. Current Sharing ____ Y/N ____ Y/N, ____ Y/N, ____ Y/N
- f. Redundant Capability ____ Y/N, ____ Y/N, ____ Y/N, ____ Y/N
- g. Internal Diode Isolation Provided ____ Y/N, ____ Y/N, ____ Y/N, ____ Y/N
- h. Hold-Up Time Required ____ msec, ____ msec, ____ msec, ____ msec
- i. Minimum Hold-Up Voltage ____ V, ____ V, ____ V, ____ V
- j. Turn On Sequence ____, ____, ____, ____, N/A__

4. REGULATION (As referenced to the nominal output voltage)

- a. Line ____(+/-)%, ____(+/-)%, ____(+/-)%, ____(+/-)%
- b. Load ____(+/-)%, ____(+/-)%, ____(+/-)%, ____(+/-)%

- c. Line and Load Combined ____(+/-)%, ____(+/-)%, ____(+/-)%, ____(+/-)%
- d. Cross Regulation ____%, ____%, ____%, ____%

5. PERIODIC AND RANDOM DEVIATION

- a. RMS ____ mv, ____ mv, ____mv, ____mv
- b. Peak-to-Peak ____ mv, ____mv, ____mv, ____mv
- c. Bandwidth ____MHz, ____MHz, ____MHz, ____MHz

6. TRANSIENT RESPONSE

- a. Dynamic Regulation, Max Excursion of the Nominal Output Voltage, with a Rated Load Change of between 10% - 100%, and 100% - 10%. ____%, ____%, ____%, ____%
- b. Recovery Time to Within the Regulation Band ____usec, ____usec, ____usec, ____usec
- c. Output Impedance ____ Ω , ____ Ω , ____ Ω , ____ Ω (specify magnitude and phase vs frequency for minimum and maximum loads)

7. TEMPERATURE

- a. Maximum Operating Temperature ____ $^{\circ}\text{C}$
- b. Maximum Non-Operating Temperature ____ $^{\circ}\text{C}$
- c. Minimum Operating Temperature ____ $^{\circ}\text{C}$
- d. Minimum Non-Operating Temperature ____ $^{\circ}\text{C}$
- e. Temperature Coefficient ____%/ $^{\circ}\text{C}$

8. STABILITY

- a. Initial Warm-up ____min.
- b. Short Term ____Min - Hrs ____ Voltage Drift
- c. Long Term ____Days ____ Voltage Drift

9. ENVIRONMENTAL CONDITIONS (operating)

- a. Humidity ____% @ ____ $^{\circ}\text{C}$

APPENDIX A

- b. Altitude _____ft
- c. Shock _____g's
- d. Vibration Amplitude _____g's, _____Frequency
- e. Salt Spray _____Duration
- f. Nuclear Circumvention _____V, _____V, _____V, _____V
- g. Time to Circumvention _____ms, _____ms, _____ms, _____ms
- h. Single Event Effects _____Y/N
- i. Total Ionizing Dose _____kRd
- j. Radiation, Total Dose Gamma _____, Neutron_____
- k. Neutron Fluence, Max Gamma Dose Rate _____
- l. Electromagnetic Pulse, Surge Current _____A, Pulse Width _____nsec
- m. Peak Voltage Susceptibility, Input _____V, _____u/m sec, Output _____V, _____u/m sec
- n. Structure-borne Noise Spectrum _____, Amplitude_____
- o. Airborne Noise Spectrum _____, Amplitude _____

10. ELECTROMAGNETIC INTERFERENCE

- a. Constraints _____
- b. Is a system EMI filter provided _____Y/N
(If "Yes" Provide a Schematic and Component Values of the Filter as well as the Characteristics of Other Connected Loads)
- c. Applicable Specifications; Conducted_____, Susceptibility_____,
Radiated _____

11. RELIABILITY/ MAINTAINABILITY

- a. Mean-Time-Between-Failures _____hrs
- b. ESS/HASS Requirements: Cycle ____Y/N

c. Is TAAF/HALT required? ___ Y/N

d. Mean-Time-To-Repair, _____Hrs

12. BUILT-IN-TEST/HEALTH AND STATUS REPORTING

a. Detail Requirements (PM/FL)_____

b. Detector Window or Tolerance of Reported Voltage(s)/Current(s)
_____+/-%, _____+/-%, _____+/-%, _____+/-%

c. Maximum / Minimum Time to Report Status____(Min) msec,____ (Max) msec

d. "Output Good" Reporting Criteria/Level _____Analog Voltage, _____Digital Level

e. Thermal Protection _____°C Inhibit, _____°C Reset

f. Input Status _____Current, _____Voltage, _____msec. prior to input decay

13. CONTROL

a. Output Inhibit/Enable _____Y/N, Inhibit Level _____V, Enable Level _____V
Referenced to _____, Maximum Current Sink _____mA

b. Output Rise to Specified Voltage after the Enable Signal is Applied _____msec.

14. PROTECTIVE DEVICES

a. Fuses Type: Fast ____, Slow ____, Current Rating _____ A

b. Thermal or Magnetic Circuit Breaker, Rating _____A

c. Power Supply Output Current Protection Current Limiting____ Y, Foldback ____Y,
Response Time _____ msec, Maximum Amplitude: _____A, _____A, _____A, _____A

d. Maximum Short Circuit Current _____A, _____A, _____A, _____A

e. Overvoltage Protection ___ Y/N, Response Time ___msec,
Maximum Amplitude: _____V, _____V, _____V, _____V

15. LOCAL STATUS INDICATION

a. AC: _____Available _____Y/N, On _____Y/N, Indicator Type _____

APPENDIX A

- b. Basic Output Indication ___Y/N, Indicator Type_____
- c. Output Within Allowable Limits ___Y/N, Indicator_____
- d. Identify Test Points _____, Source Impedance_____ Ω

16. ELECTRICAL INTERFACE

- a. Input Interface: Connector _____, Terminal Strip _____,
Solder Lugs_____
- b. Output Interface: Connector, _____, Terminal Strip _____,
Solder Lugs_____
- c. Monitoring and Control: Connector _____, Terminal Strip _____,
Solder Lugs _____
- d. Electrostatic protection must be provided at required electrical interfaces _____
- e. Enclosure/Chassis Safety Ground Terminal Strip _____, Solder Lug _____

17. PHYSICAL REQUIREMENTS

- a. VME/ATR Rack Assembly
- b. Standard Rack Size _____, Depth___Height___Width___
- c. System Interface Specifics: Location of Electrical Interfaces, Protrusions, Mounting Hole Locations, Cooling Surfaces
- d. Dimensions: _____ in. Width, _____ in. Length, _____ in. Height. Provide outline and mounting documentation, if available
- e. Weight _____ Lbs.
- f. Location of Center of Gravity_____
- g. Lifting Points
- h. Shipping/Packaging Requirements (Special)

18. PROHIBITED MATERIALS

- a. Prohibited materials should be tabulated consistent with program requirements.

19. COOLING REQUIREMENTS

- a. Conduction ____ Y/N
- b. Heat Transfer Surface Finish _____
- c. Thermal Interface Gasket Provided by Vendor ____ Y/N
- d. Convection: Natural ____ Y/N, Forced ____ Y/N
- e. Forced Convection, Air Temperature ____ °C, Quantity ____ ft/min,
Allowable Pressure Drop ____ Lbs.
- f. Cooling Filter ____ Y/N, Removeable during operation ____ Y/N
- g. Liquid Cooled, Temperature ____ °C, Flow Rate ____ gal/min.

20. Qualification Tests

- a. Verify Achievement of Performance Requirements _____

21. Production Acceptance Testing

- a. Accept/Reject Criteria for Production Power Supplies _____

Supplemental Performance Specification Checklist for AC Output Power Supplies

OUTPUT CONFIGURATION

Single Phase 2-Wire []
Three Phase Delta 3-Wire []
Open Delta 3-Wire []
Three Phase Wye 3-Wire [] 4-Wire []
Symmetrical Ground []

OUTPUT POWER	MINIMUM	NOMINAL	MAXIMUM
Output Real Power			W
Output Apparent Power			VA
Crest Factor	N/A		
Power Factor (Leading)			1.0
Power Factor (Lagging)			1.0

OUTPUT VOLTAGE

RMS Value _____VRMS (L-N), _____VRMS (L-L)

Initial Setting _____% maximum

Regulation, Load and Input Line _____% maximum

Voltage Unbalance _____VRMS maximum (Multiphase Outputs Only)

Angle Unbalance _____(°) maximum (Multiphase Outputs Only)

Output Voltage (THD) _____% maximum

Output Voltage DC Offset _____ (mV) maximum

FREQUENCY

Output Frequency _____ (Hz)

Frequency Accuracy _____% maximum

Frequency Stability _____% maximum

OUTPUT RIPPLE AND NOISE

MIL-STD-704 []

MIL-STD-461 []

FCC Class A []

FCC Class B []

SYSTEM INTEGRATION

Backfeeding Protection []
Synchronization to Line []
Parallel Operation []

UPS CONSIDERATIONS

Hold-Up Time _____(min) Minimum
Recharge Time _____(min) Maximum
Transfer time _____(ms) Maximum

APPENDIX B

Design Review Checklists for Power Systems and Power Supplies

Sample Design Review Checklist for Power Systems

SYSTEM ARCHITECTURE

- Have critical system parameters been identified and prioritized?
- Has or will a system power architecture optimization be performed?
- Are the results of the System Architecture Study sufficiently documented such that meaningful reference can be made during the actual system development phase?
- Does the power supply specification reflect optimized system studies?
- Does the method of distribution complement the system architecture approach?
- Is the prime power AC or DC?
 1. If the distribution is ac:
 - a. What is the frequency range?
 - b. Is it three-phase or single-phase power?
 - c. Is bus switching involved?
 2. If the distribution is DC:
 - a. Is bus switching involved?
 - b. Is distributed energy storage required?
 3. Common to both AC and DC:
 - a. What is the load power level?
 - b. What are the load voltage requirements?
 - c. Are cable power losses and voltage drop considered?
 - d. What is the cable impedance versus frequency?
 - For accurate modeling, can it be a lumped parameter or must it be distributed?
 - Does the cable impedance overwhelm the source impedance?
 - e. Are the distribution cabling, junction boxes, or any other hardware elements subject to any EMI/EMC/EMP requirements?
 - f. What types of protection devices are used?
 - How is platform and system coordination achieved?
 - g. What safety issues are involved?
 - h. What level of shielding is required?
 - How are shields terminated?
 - i. How is grounding performed?
 - j. Are cables treated as emitters and susceptors, and are adequate separation and shielding provided?

APPENDIX B

PRIME POWER SOURCE

- Have all power source impedance parameters (magnitude and phase) been defined under all operating conditions? This should include the transient and sub-transient reactance of generators as appropriate.
- Has system stability at the power source/system interface been specified?
- Are hold-up requirements realistic?
- Have critical system loads requiring hold-up been segregated from the total system load?
- When applicable, are MIL-STD-1399 Section 300 spike test requirements realistic with regard to specified source impedance (0.2 ohms)
- Are power source line voltage drops, as specified in the applicable power source specification, realistic when considering the particular application?
- Are power supply performance requirements during abnormal power source conditions sufficiently specified?
- Are inrush current limits realistically specified?
- Are there reactive elements within the power distribution network in excess of those detailed in the power supply specification?

ELECTROMAGNETIC COMPATIBILITY

- Have the requirements of MIL-STD-461 been realistically tailored to the power supply?
- Have the power supply external interfaces been defined as complex impedances? Have common mode specifications been adequately imposed on the power supply?
- Does the specification provide sufficient details of system grounding requirements?
- Will a simulation model be adhered to during the initial design phase of the system?
- Are power supply output ripple specifications consistent with EMI requirements?

MONITORING AND CONTROL

- Are the monitoring and control requirements realistically specified with regard to the required features to be implemented internal to the power supply?

- Are monitoring and control limits sufficiently wide to allow for adequate hysteresis for limit detectors and on/off functions?
- Is the monitoring specified to avoid false indications during start-up and shut-down?
- Have the EMI requirements with regard to monitoring and control interface cables been sufficiently specified?
- Does the I/O for the power supply provide for adequate separation between the monitor, control, and power lines?

ENVIRONMENTAL ISSUES

- Are the power supply environmental specifications tailored with regard to the overall system environmental requirements?

SPECIFYING LOAD POWER

- Has stability at the interface between the power supply and its load been specified?
- Have the load impedances (magnitude and phase) been defined to support stability analyses?
- Has the total load power been defined including the conditions under which it applies?
- Do the loads occur coincidentally or in sequence?
- Do the minimum load specifications take into account sub-system testing?
- Is the power supply required to operate continuously or intermittently up to the specified overload trip point?
- Is the power supply required to latch or provide smooth recovery after removal of an overload condition?
- Are the interconnect wiring and connector pins adequately rated for worst-case load conditions and voltage drop?
- Has the effect of load loss regulation been taken into account?
- Have the allowable peak power demands during turn-on been sufficiently specified?
- When pulsed loads exist has the current amplitude and time related pulse shape characteristic been specified?

APPENDIX B

- Has the allowable degree of voltage deviation and recovery response time during a pulsed load event been specified?

PROTECTION

- Has the power supply specification for protection taken into consideration fault related conditions associated with the input power source, the power supply and the load?
- Have the interface wiring and connector pins been adequately derated for worst case fault conditions?
- Have the recovery features for the power supply after an overload or short circuit removal been adequately specified?
- Has overload protection taken into account peak transient currents during turn on?
- Have protection features been considered to protect the power supply from over/under voltage conditions and reverse polarity conditions?
- Is the power supply adequately protected from over temperature conditions?
- Is the power supply protected from an external load-to-load short?
- Is the power supply protected from open/short remote sense leads?
- Will the parallel connected power supplies adequately share current?
- For multi-phase inputs will the power supply remain safe with loss of one or more phases?
- Are ganged circuit breakers used for multi-phase power sources?
- Will the power supply operate continuously up to the specified overload trip point?

TESTING

- Has a system level test plan been generated?
- Does the power supply specification adequately address system level related test parameters that need to be considered during the power supply development phase?
- Are there sufficient test nodes available such that test anomalies can be isolated at the system test level?

Sample Design Review Checklist for Power Supplies

ELECTRICAL CHECKLIST

General

- Have requests been initiated for approval of non-standard components?
- Have tolerance effects, including those due to environment, been considered on all critical component parameters?
- Are all components applied within their derated electrical and environmental limitations?
- Have transient effects been considered?
- Are there any storage life limited components used and, if so, can they be eliminated or their effect minimized?
- Have any components been overspecified, e.g., can less qualified components suffice?
- Have adjustments been eliminated wherever possible?
- Have circuit stability, race conditions and/or areas of critical timing been identified and analyzed?
- Do all components have a second source of supply?

Capacitors

- Are the capacitors properly derated with respect to working voltage, ripple current and case temperature?
- Are the capacitors adequately protected against surge voltages which exceed the rated operating voltage?
- Have the effects of AC ripple current on "hot-spot" temperature been considered?
- Have temperature-compensating or low-temperature-coefficient capacitors (mica or ceramic) been used wherever high stability is required?
- Are tantalum capacitors bypassed with ceramics for frequencies above 100 kHz?

Resistors

- Are the resistors properly derated with respect to power dissipation, voltage, and temperature?
- Has the rated wattage been adjusted in cases where short mounting leads are used?
- Can any potentiometers be replaced by fixed resistors?
- Have noninductive types been used in high-frequency applications?
- Has peak current capability been considered with respect to wire wound resistor fusing current?

Microelectronics

- Are linear devices properly derated with respect to output current, input voltage, power supply voltage and temperature?

APPENDIX B

- Are digital devices properly derated with respect to fan-out, power supply voltage and temperature?
- Has adequate power supply decoupling been employed?
- Has the effect of operating frequency and switch speed on digital device power dissipation been considered?
- Have unused logic inputs been properly terminated by grounding or through a pull-up resistor?
- Have effects of wiring and connectors on propagation delay been considered?
- Have adequate precautions been taken against electrostatic discharge (ESD) damage?

Transistors

- Are the devices adequately derated with respect to voltage, current, power dissipation and temperature?
- Does transistor operation approach any absolute rating including Safe Operating Area (SOA) under any unusual variations of supply voltage or load?
- Will the circuit perform satisfactorily with randomly selected transistors?
- Is power gain a critical consideration in this application?
- Is noise figure a critical consideration in this application?
- How much leakage current is expected over the operating ambient temperature range?

Diodes

- Are devices adequately derated with respect to voltage, current, power dissipation and temperature?
- How much reverse recovery time do the diodes require?
- How much reverse current can be tolerated and how much reverse current will flow at the operating ambient temperature range?
- Does the circuit perform satisfactorily with randomly selected diodes? Is snubbing required?
- What zener voltage reference is required, compared with the zener reference voltage expected at the actual operating current levels?

Transformers, Chokes and Coils

- Are the units adequately derated for voltage, current, flux density and temperature?
- Is Q a critical consideration in this circuit application?
- How close is the highest operating frequency to the resonant frequency of the chokes or coils?
- Has a shielding requirement been established? (Faraday Shield)
- Where a hum problem exists, has special consideration been given to core construction?

Connectors and Plugs

- Does the number of active pins per connector conform to the recommended limit (unused spares requirement)?
- Are a sufficient number of spare pins available on each connector?
- Is it necessary to parallel connector pins to obtain adequate current-carrying capacity? (Do not depend on equal current-sharing.)

Miscellaneous Components

- Has consideration been given to the current rating of wire?
- Has the current rating of wire been reduced in cases where voltage drop is important?
- Is wire color-coding required, and if so, is it in accordance with the proper standards or specifications?
- Has the placement of components on printed wiring boards been considered from the crosstalk point of view?
- Does a heat dissipation problem exist on printed wiring boards?
- Is a keying scheme employed to prevent interchanging printed wiring boards?
- Are integrated circuits, transistors, diodes, and polarized capacitors properly oriented on printed wiring boards?
- Do any large potential gradients exist between adjacent pins or connectors on printed wiring boards?

MECHANICAL CHECKLIST

General

- Was an adequate safety factor or design margin considered in all mechanical design?
- Is there adherence to standards for bend radii, crimping, soldering, welding, brazing, etc., which are consistent with the application?
- Are adequate methods provided for packaging, mounting and cooling components subject to performance degradation or reliability failure under a worst-case thermal environment?
- Is redundancy provided in critical subsystems to ensure mission success?
- Is the use of unqualified mechanical components kept to a minimum?
- Are those components with storage life and/or operational life restrictions kept to a minimum?
- Have protective measures been incorporated to prevent installation errors?
- Is there complete interface compatibility (mechanical-to-mechanical, mechanical-to-electrical, etc.)?
- Has protection from mechanical abuse by the use of suitable mechanical protection techniques (packaging, mounting and structural) been incorporated?
- Has an adequate structural analysis (static and dynamic) been performed on all equipment which contains or supports systems or subsystems?
- Have limited-life items been identified?
- Have assembly and chassis mounting locations been reviewed for shock and load distribution?
- Has the design been reviewed for possible simplification?
- Have pins been provided to absorb shock and vibration loads between assemblies and structures to prevent damage to mating connectors?
- Has the lowest-cost type of fabrication compatible with equipment specification requirements been chosen? Are alternate construction and "make-from" drawings applicable?
- Is the proper orientation of the unit for placement in its location made obvious by its design or labeling?
- Does the arrangement of components follow a functional flow to preserve simplicity and

APPENDIX B

accuracy?

- Have clamps, grommets, or other protective devices been employed to protect wiring against damage?
- Do all screws have locking devices?
- Are all plug-in items secured with positive holding clamps?
- Are wires clamped so that terminals do not receive the strain of cable movement?
- Have cantilevered brackets been eliminated?
- Have stiffening means or members been employed to achieve maximum rigidity with minimum weight?
- Do wires have enough slack to permit relative motion between terminals during shock and vibration without putting tension on the wire or wire connections?

Tolerances

- Has a worst-case adverse tolerance buildup been performed for each critical mechanical interface?
- Can close tolerances be broadened?
- Will tolerances remain within specified limits at extreme temperatures?

Fasteners

- Have standard fasteners been utilized throughout, with a major attempt at minimizing sizes and types?
- Have proper fasteners been employed to satisfy EMI and drip-proof requirements?
- Do the quantity and strength of fasteners satisfy the functional requirement?
- Are fasteners which are used as structural members of sufficient size and number to meet equipment requirements?
- For access doors and panels, are easily manipulated fasteners incorporated in absolute minimum quantities?
- Are access door/panel fasteners captivated?
- For thread-type fasteners, has galling been addressed?

Environment

- Has adequate testing been proposed to demonstrate satisfactory operation under simulated worst-case ambient conditions such as temperature, humidity, shock, vibration, pressure, penetration/abrasion, ambient lighting, mounting position, exposure (wind, rain, snow), sea state and operator skills?
- If the operating environment results in internal condensation, has a means for draining, drying, or using a sealed system been included?
- Does vulnerable equipment have protection from dust, humidity, dirt, contamination, salt spray, etc.?
- Have either of the following been utilized to enable equipment to withstand the shock/vibration environment?
- Have any of the following corrosion techniques been utilized on exposed equipment?
 - Corrosion resistant materials
 - Plating and protective finishes

- Dissimilar metal contact avoidance
- Environmental control (water entrapment prevention, atmospheric moisture removal, etc.).
- Has electrolytic action under specification extremes of humidity and temperature been minimized?
- Have questionable areas been analyzed for shock or vibration?
- Are heavy components mounted as low as possible to keep center of gravity sufficiently low to meet shock and vibration requirements?
- Are components spaced and rigidly held so as to prevent contact with each other during shock or vibration?

Materials

- When adhesives are used, are the adhesives selected based on environment and materials which they are bonding?
- Are the materials selected for fabrication compatible with the strength, weight, electrical stress factors, specified environment and lowest cost of the finished component?
- Are all materials corrosive-resistant, nonflammable and nontoxic?

Thermal

- Has a thorough thermal analysis determined that component operating temperatures and ambient temperatures will not exceed specified derated maximums (as applicable)?
- Are sufficient air openings and heat paths provided to satisfy cooling requirements?
- Are heat-sensitive components isolated from hot spots?
- Have heat sinks and heat dissipation devices been utilized?
- Has sufficient space been left between resistors and other heat-producing or heat-sensitive components?
- Has heat dissipation been considered for both peak and average conditions?
- Has the unit been designed to function at maximum operating temperature for peak and average conditions?

RELIABILITY CHECKLIST

Component Level

- Have component derating guidelines been observed?
- What is the failure history of this item?
- Is the item critical; i.e., would its failure result in system failure?
- What are the item's possible modes of failure?
- What steps have been taken in the item's application or system design to eliminate or minimize the effects of these modes of failure?
- Is it possible to introduce the concepts of redundancy and/or use the item at derated performance levels?
- What is known about its storage life, operating time or cycles; i.e., how much time or cycles, operating and nonoperating, may be accumulated without significantly degrading its

APPENDIX B

reliability?

- If the component is newly developed, what are its critical weaknesses, and what provision has been made in the design so that modifications can be made at the earliest possible time if these or other weaknesses show up in testing?
- Is it physically and functionally compatible with its neighboring components; i.e., will the physical location affect its performance or reliability?
- Are any unusual quality control or vendor problems expected?

Circuit/Assembly Level

- Does the item perform more than one function?
- Have critical components been identified?
- If an established design, is it being used as in previously experienced environments and at normal operating levels?
- Has the item been designed as simply as possible; i.e., have human factors been considered to prevent errors such as reversed wiring or other misassembly?
- Have physical features which might adversely affect performance or reliability been taken into account; e.g., are there any sharp corners which might damage components or cause wiring insulation failure?
- How might the design be modified to improve reliability, and what effect would the modification have on such factors as performance, cost, weight, availability, schedules, maintainability, etc.?
- Has the item or system been designed for ease of production, assembly, maintenance and inspection?
- Have handling, transportation, packaging and environments other than the specified operational environments been taken into account?
- Have worst-case effects of tolerance buildup been considered?
- Would any component failure modes cause secondary failure; i.e., cause damage or failure of other components?
- Has the regulation control loop been analyzed and tested for adequate gain and phase margin for all operating conditions?

SAFETY CHECKLIST

General

- Do engineering drawings contain safety notes and/or critical characteristics?
- Does unit contain hazardous/toxic materials?
- Is a display test function and power-on light or flag available?
- Is there an overtemperature warning light or signal?
- Have "fail-safe" principles been incorporated in the design?
- Can maintenance or adjustment be performed safely?
- Do units of 45 to 150 pounds have provisions for two-man lifting?

Electrical

- Is equipment designed so that all external components will be at ground potential at all times?
- Have bleeder resistors, current-limiting resistors, capacitors, shorting devices, and similar safety precautions been incorporated where required?
- Do resistive bleeder networks consist of at least two equal resistors in parallel?
- Have 3-phase power applications been examined for potential safety hazards regarding fuses, switches, or other operator controlled devices?
- Is there adequate protection against dangerous voltages?
- Are discharging devices that actuate automatically when equipment is opened provided for potentials above 30 volts?
- Is wiring routed through plugs and connectors so that removal of a plug or connector will not expose "hot" leads?
- Are fuseholders provided so that only the cold terminal can be touched?
- Are adjacent plugs or connectors keyed to prevent interchanging connections?
- Are assemblies with potentials exceeding 500 volts completely enclosed?
- Do completely enclosed assemblies with potentials exceeding 500 volts have interlocks without bypass, automatic discharging devices and grounding rods, as applicable?
- Do voltage test point dividers have at least two equal resistors in parallel between the test point and ground?
- Have voltage dividers or other such devices to reduce the voltage at test points to a relatively low potential level been provided when potentials in excess of 30 volts peak are required to be measured?
- Are ventilation holes small enough to prevent inadvertent insertion of test probes or fingers?
- Are high voltage points (>30 Vrms/42Vdc) guarded with barriers that are stenciled with a warning sign advising of the highest voltage available?
- Have overload protective devices been provided where necessary to prevent overheating of components and wiring?
- Are electrical terminals clearly marked (e.g. + or -, signal or ground)?
- Have fail-safe devices been provided so that a malfunction in one unit or subassembly cannot cause malfunction in other units or subassemblies, with resultant serious damage to the system and possible injury to personnel?
- Are electrical cables routed such that they are not near sources of high temperature?

Warning Signs & Labeling

- Are sufficient high-potential guards and warning plates provided?
- Have guards or warning plates been provided for protection against high temperature, moving or protruding components?
- Do display labels for each termination have the same code symbol as the wire or line attached to it?
- Are completely enclosed assemblies with potentials exceeding 500 volts clearly marked "DANGER: HIGH VOLTAGE (maximum voltage) VOLTS" (Reference ANSI-Z35.1 for color-coding)?
- Are warning signs in accordance with the design and color-coding requirements (e.g., ANSI-Z35.1 latest revision)?

APPENDIX B

- Is there a warning plate reading "DANGER-do not energize his equipment unless frame and all exposed metal components are grounded" attached to the front panel of equipment with leakage current exceeding 5 mA to ground?

MAINTAINABILITY CHECKLIST

Reparability

- Have all replaceable modules, subassemblies, or components been made plug-in for rapid replacement?
- Have screw holes for mounting components, cover plates, access panels and similar components that do not require precise alignment, been made oversize to facilitate assembly?
- Have replaceable components and assemblies (modules, printed wiring boards, etc.) been grouped functionally?
- Do any replaceable modules contain any components or circuits that are not functionally related?
- Does chassis design provide sufficient structural support, rails, integral rests or other devices to prevent component damage during bench repair or test?
- Have guide channels, positioning pins, or other aligning devices been provided for all plug-in units to prevent pin damage or improper assembly?
- Have connectors been keyed, coded, or otherwise polarized to prevent improper mating?
- Is captive hardware (screws, fasteners, etc.) used on access panels, cover plates and similar devices to prevent dropping or loss of screws, and to avoid possible damage to other assemblies?
- Has proper storage and protection been provided for slack harnesses or service loops attached to pull-out or hinged assemblies, to prevent pinching, chafing, sharp angle bending, or wire breakage due to repeated flexing?
- Have all terminals and components been spaced so that maintenance action will not damage adjacent leads or components?
- Have access panels and covers been fitted with quick-disconnect fasteners?
- Do any modules exceed the throwaway cost limit established by the level-of-repair analysis? Explain.
- Are all fuses located so that they can be seen and replaced without removing any other components or subassemblies? Are colocated ready-service spares required?
- Are provisions made for support of units while they are being removed or installed?
- When tool-operated fasteners are necessary, do these require only standard hand tools?
- Do units weighing more than 10 pounds have grasping features to assist in removing, replacing or carrying?

Labeling and Identification

- Are all replaceable modules, subassemblies or components readily identifiable with adequate labeling or marking?
- Are all significant labels or markings in full and unobstructed view in the mounted position?
- Have all wire terminals and connections been properly identified?

- Is each wire properly identified according to its terminal, connector pin, etc.?
- Has clear functional identification been provided for each control, indicator, connector and test point?
- Does the exposed surface of installed modules contain only that information required by the maintenance technician for positive and accurate identification?
- Are all controls labeled?
- Do all module mounting positions have alphanumeric or color-coded symbols clearly identifiable and adjacent to the corresponding code on the module when properly mounted?

Controls and Displays

- Have screwdriver adjustments been placed so that there is sufficient clearance for the screwdriver handle?
- Have recessed screwdriver adjustments been provided with screwdriver guides?
- Are all controls and displays clearly, accurately and uniformly identified?
- Do meters or other displays used for maintenance provide information which requires a minimum of interpretation by the technician?
- Is uniformity observed in shape, size, arrangement and operation of controls (e.g., all toggle switches in "up" position for normal operation)?

Accessibility

- Are connectors located and mounted in a manner that facilitates rapid assembly or disassembly during repair or replacement?
- Is the design such that malfunctioning components, modules or assemblies can be removed without the removal of adjacent components or assemblies?
- Are the multi-pin connectors of the type that permits removal and replacement of individual pins without disassembly of the entire connector?
- Are any components mounted in such a manner that the mounting screwheads are "blind," i.e., underneath, or hidden by other mounting plates, panels, or structural members?

Adjustments

- Have adjustments been minimized?
- Have all unnecessary blind (hidden) screwdriver adjustments been avoided?
- Where blind screwdriver adjustments cannot be avoided, have screwdriver guides (or extension shafts) been provided?
- Have critical, close-tolerance, and interacting adjustments been avoided?
- If critical adjustments are necessary, have vernier devices been provided?
- Are positive locking devices provided to assure retention of settings of adjustments or alignment devices that are susceptible to vibration or shock?

APPENDIX C

Modified COTS/NDI and Custom Power Supply Supplier Evaluation

Note: This provides only technical aspects of the manufacturer’s evaluation, and should be used in conjunction with the other business related surveys when conducting an evaluation of a potential supplier. This checklist provides guidelines, and must be tailored for each specific application and vendor, as all questions may not be applicable for every procurement.

A. PARTS AND MATERIAL SELECTION

- Use of (QML) parts, particularly for applications requiring extended temperature ranges Y [] N []
- Electrical parameters of parts are characterized to requirements derived from the Design Reference Mission Profile to ensure that all selected parts are reliable for the proposed application Y [] N []
- All parts are derated electrically and thermally Y [] N []
- A Preferred Parts List is established prior to detailed design Y [] N []
- Parts screening is tailored based on maturity Y [] N []
- Highly integrated parts (e.g., Application Specific ICs (ASICs)) are used to reduce:
 - The number of individual discrete parts/chips Y [] N []
 - The number of interconnections Y [] N []
 - Size, power consumption, and cooling requirements, and Y [] N []
 - Failure rates Y [] N []
- Quality is measured by:
 - Certification by supplier Y [] N []
 - Compliance with EIA-623, “Procurement Quality of Solid State Components by Governments Contractors,” July 1994 Y [] N []
 - Verification to historical database Y [] N []
 - Particle Impact Noise Detection for cavity devices Y [] N []
 - Destructive Physical Analysis for construction analyses Y [] N []
- Strategy for parts obsolescence and technology insertion is established Y [] N []
- Vendor selection criteria established for non-QML parts considers:
 - Qualification, characterization and periodic testing data Y [] N []
 - Reliability/quality defect rates Y [] N []
 - Demonstrated process controls and continuous improvement program Y [] N []
 - Vendor production volume and history Y [] N []
- Minimum acceptable defects for in-coming electronic piece parts:
 - Maximum of 100 defective parts per million Y [] N []

APPENDIX C

B. DESIGN REVIEWS

- Formal procedures are established for Design Reviews Y [] N []
- Design Reviews are performed by independent and technically qualified personnel Y [] N []
- Entry and exit criteria are established Y [] N []
- Checklist and references are prepared Y [] N []
- Manufacturing, product assurance, logistics engineering, cost and other disciplines have equal authority to engineering in challenging design maturity Y [] N []
- Design Review requirements are flowed down to the subcontractors Y [] N []
- Subcontractors and customers participate in the design reviews Y [] N []
- Design reviews are conducted as follows:
 - PDR: 20% of the design is complete Y [] N []
 - IDR: 50% of the design is complete Y [] N []
 - CDR: 95% of the design is complete Y [] N []

C. THERMAL ANALYSES

- Determination and allocation of thermal loads and cooling requirements to lower-level equipment and parts are made based on the DRMP and the system self-generated heat Y [] N []
- Preliminary analyses are refined using actual power dissipation results as the thermal design matures Y [] N []
- The junction-to-case thermal resistance values of a device are used for the thermal analysis Y [] N []
- Thermal Survey (e.g., infrared scan) is conducted to verify the analysis Y [] N []

D. DESIGN RELEASE

- Design release process requires concurrent review by all technical disciplines Y [] N []
- Measurable key characteristics and parameters are identified on drawings, work instructions and process specifications Y [] N []
- Designs are released to production after:
 - Completion of all design reviews Y [] N []
 - Closeout of all corrective action items Y [] N []
 - Completion of all qualification testing Y [] N []
- A producible, supportable design is characterized by:
 - Stable design requirements Y [] N []
 - Completed assessment of design effects on current manufacturing processes, tooling and facilities Y [] N []
 - Completed producibility analysis Y [] N []

- Completed rapid prototyping Y [] N []
- Completed analysis for compatibility with:
 - COTS/NDI interfaces Y [] N []
 - Subcontractor design interfaces Y [] N []
 - Form, Fit, and Function at all interfaces Y [] N []
 - Design release practices, or equivalent, of the prime contractor are flowed down to the subcontractors Y [] N []

E. DESIGN LIMIT QUALIFICATION TESTING

- Design limit/margin testing based on the DRMP, is integrated into the overall test plan, especially with engineering, reliability growth and life testing Y [] N []
- Design limit qualification tests are performed to ensure worst case specification requirements are met Y [] N []
- Highly Accelerated Life Tests (HALT) are performed to determine the design margins:
 - When operating at the expected worst case environments and usage conditions Y [] N []
 - To identify areas for corrective action Y [] N []
- Increased stress to failure conditions are included toward the end of Test, Analyze, and Fix (TAAF) testing to identify design margins Y [] N []
- Engineering development tests are performed beyond the design limits to measure the variance of the functional performance parameters under environmental extremes Y [] N []
- The failure mechanism of each failure, including stresses at the worst case specification limits, is understood Y [] N []

F. MANUFACTURING PLAN

- Identification, during design, of key product characteristics and associated manufacturing process parameters and controls to minimize process variations and failure modes Y [] N []
- FMECA of the manufacturing process during design for defect prevention Y [] N []
- Specified manufacturing process variability (e.g. Cpk) is within the design tolerances Y [] N []
- Variations of test and measuring equipment are accounted for when determining process capability Y [] N []
- Rapid prototyping for reduced cycle time from design to production Y [] N []
- Design For Manufacturing and Assembly to develop simplified designs Y [] N []
- Design for agile manufacturing to quickly adapt to changes in production rate, cost and schedule. Y [] N []
- Contingency planning for disruption of incoming parts, variations in manufacturing quantities, and changes in manufacturing capabilities Y [] N []

APPENDIX C

- Controlled drawing release system instituted Y [] N []
- Process proofing/qualification Y [] N []
- Product/process changes that require qualification are defined Y [] N []
- Flowcharts of manufacturing processes at the end of EMD, validated at the start of LRIP Y [] N []
- Facilities, manpower, and machine loading for full rate production are validated during LRIP. Production readiness reviews performed on critical processes Y [] N []
- Subcontractor process capabilities integrated into the prime contractor's process capabilities Y [] N []
- Specific product tests and inspections replaced with Statistical Process Controls (SPC) on a demonstrated capable and stable process Y [] N []
- Closed loop discrepancy reporting and corrective action system, including customer and subcontractor discrepancies Y [] N []
- Post production support plan established and maintained for:
 - Repair capability Y [] N []
 - Obsolescence of tools, test equipment and technology Y [] N []
 - Loss of contractor expertise and vendor base, and Y [] N []
 - Time/cost to reestablish production line Y [] N []

Metrics Include:

- Measurable key characteristics and parameters are identified on drawings, work instructions and process specification Y [] N []
- SPCs (e.g., Cpk>1.33) are established for key characteristics Y [] N []
- Critical processes under control prior to production implementation Y [] N []

G. MANUFACTURING PROCESS PROOFING/QUALIFICATION

- Proofing simulates actual production environments and conditions Y [] N []
- “Proof of Manufacturing” models used to verify that processes and procedures are compatible with the design configuration Y [] N []
- First article tests and inspections included as part of process proofing
- Conforming hardware consistently produced within the cost and time constraints for the production phase Y [] N []
- Key processes are proofed to assure key characteristics are within design tolerances Y [] N []
- Process proofing must occur with:
 - A new supplier Y [] N []
 - The relocation of a production line Y [] N []
 - Restart of a line after a significant interruption of production Y [] N []
 - New or modified test stations, tools, fixtures, and products Y [] N []
 - Baseline and subsequent changes to the manufacturing processes Y [] N []
 - Special processes (non-testable/non inspectable) Y [] N []
 - Conversion of manual to automated line Y [] N []

H. SUBCONTRACTOR CONTROL

- Subcontractor/supplier rating system with incentives for improved quality, reduced cost and timely delivery Y [] N []
- Flowdown of performance specification or detail Technical Data Package, depending on the acquisition strategy Y [] N []
- Subcontractors integrated into Integrated Product Teams to participate in the development of DRMP requirements Y [] N []
- Waiver of source and receiving inspections for subcontractors meeting certification requirements, depending on the product’s criticality Y [] N []
- Subcontractor controls critical sub-tier suppliers Y [] N []
- Subcontractor notifies prime of design and process changes affecting key characteristics Y [] N []

I. MANUFACTURING SCREENING

- Highly Accelerated Stress Screening (HASS) is performed as an environmental stress screen to precipitate and detect manufacturing defects Y [] N []
- HASS stress levels and profiles are determined from step stress HALT Y [] N []
- HASS precipitation screens are normally more severe than detection screens Y [] N []
- Product is operated and monitored during HASS Y [] N []
- The HASS screen effectiveness is proofed prior to production implementation Y [] N []
- HASS is performed with combined environment test equipment Y [] N []
- HASS stresses may be above design specification limits, but within the destruct limits, for example:
 - High rate thermal cycling Y [] N []
 - High level multi-axis vibration Y [] N []
 - Temperature dwells Y [] N []
 - Input power cycling at high voltage Y [] N []
 - Other margin stresses are considered when applicable to the product Y [] N []
- Alternative traditional environmental stress screening (ESS) guidelines for manufacturing defects may be in accordance with Tri-Service Technical Brief 002-93-08, “Environmental Stress Screening Guidelines,” July 1993 (if applicable) Y [] N []
- Parts Screening:
 - 100% screening required when defects exceed 100 PPM Y [] N []
 - 100% screening required when yields show lack of process control Y [] N []
 - Sample screening used when yields indicate a mature manufacturing process Y [] N []

APPENDIX C

J. QUALITY

- Does supplier have a formal, documented quality control system? Y [] N []
- What quality control system specification is the quality assurance system derived from (e.g., ISO 9000, etc.?)
- Is the manual of quality control procedures updated continually to the latest industry practices and requirements of the customer and government agency? Y [] N []
- Statistical Sampling Procedures, if applied, are based on what standard(s)? Y [] N []
- Is the Seller currently ISO 9000 certified? Y [] N []

APPENDIX D

Platform Power Characteristics

Shipboard

Electrical Power

The ship service power distribution system, supplied by the ship's alternators is 440 VAC, 60 Hz, 3-phase, 3-wire, ungrounded delta-connected power whose characteristics are delineated by MIL-STD-1399 Section 300 as Type I Power. This is referred to as primary shipboard power. A deviation is required if the user of electrical power requires more than 5 kW of power with any characteristics different from primary shipboard power (unless the power is in certain categories and used for service of aircraft, aviation support equipment, or aviation units under test). For less than 5 kW of power, the user can use 115 VAC single-or 3-phase power.

The deviation procedure requires a cost-benefit tradeoff analysis which addresses the impact on the ship platform versus equipment impact in terms of weight, space, power consumption, reliability, Total Ownership Cost and total ship effectiveness. Besides the primary shipboard power, there are thirteen other combinations of power specified by MIL-STD-1399 Section 300. Use of any of these alternatives has some impact on the electrical power and distribution system. The tradeoff considerations involved in using any power other than the primary shipboard power are discussed.

Three-Phase Versus Single-Phase Power

The primary shipboard power is ungrounded but has a virtual alternating current (AC) ground established at each equipment by means of capacitors to chassis in the equipment EMI filters. For any unbalance in virtual grounds between equipment, alternating current will flow in the hull of the ship. These hull currents are considered undesirable for a variety of reasons. Use of single-phase power creates the greatest possible unbalance. Unbalanced loads are more significant offenders than unbalanced leakage impedance to ground. The unbalanced loads can include filter capacitors to ground. All of this contributes to common mode noise problems.

Because power supplies can be designed to be smaller and lighter using 3-phase prime power, this is preferred from both the ship's power system and user viewpoints.

Occasionally, there is an advantage to using existing commercial or military single-phase equipment. In these cases, if the anticipated location and magnitude of induced hull current is considered satisfactory and the power system balance requirements are met, there is virtually no penalty to the power system in the tradeoff analysis. Hence, MIL-STD-1399 Section 300 lists the single-phase alternative immediately after each 3-phase alternative in the order of preference in selecting system voltages.

In the absence of any clear advantage to doing otherwise, 3-phase power should be specified for shipboard equipment and systems.

60 Hz Versus 400 Hz Power

The use of 400 Hz power on a ship requires that a frequency changer, in the form of a motor-generator set or a solid-state, frequency changer, be added to the ship's power system to convert

APPENDIX D

60 Hz to 400 Hz power. Before off-line switching power technology, there was a significant advantage to the user with 400 Hz power due to reduced magnetic component size. With line-frequency transformers eliminated from the power supply, the only advantage is in slightly smaller EMI filters. This is only true when the transformer isolated rectification scheme is single phase or multi-phase with a low number of pulses per cycle. However, careful electrical and mechanical design is required to ensure minimal common mode current. Most EMI testing is done for differential mode and potential common mode problems which are not uncovered during testing. In cost-benefit tradeoff analyses, frequency changers add weight, space, power consumption, Total Ownership Costs and reduce reliability which totally offsets any benefits in using a 400 Hz shipboard power architecture.

MIL-STD-1399 Section 300 and Navy policy recognize the need for 400 Hz power for aircraft, aviation support equipment and aviation units under test aboard ships. Except for aircraft/avionics-related uses, approval of deviations requesting the use of 400 Hz power on ships is expected to be rare.

In the absence of any clear-cut advantage for doing otherwise, 60 Hz power should be specified for shipboard equipment and systems not related to aircraft.

440 VAC Versus 115 VAC Power

The preferred voltage from the ship power system viewpoint is 440 VAC since it is the output of the ship's alternators. Unfortunately, this voltage level is beyond the state-of-the-art of active components used in the technological approaches needed to increase the output power density of power supplies and is expected to remain so in the foreseeable future (except for higher-powered units). Therefore, the voltage must be stepped down passively by the use of autotransformers or isolation transformers. Once this is accepted, the real consideration becomes the power level at which step-down is executed. An alternative is to make an intermediate voltage bus conversion at higher power on a centralized basis.

The volume and weight of transformers vary approximately as $(VA)^{0.75}$, where VA is the volt-ampere rating. For this reason it is inefficient from a weight and volume (and probably cost) viewpoint to step-down the voltage in a typical power supply (500 W) and conversion should be considered at the equipment, cabinet, group of cabinets, or electronic equipment bay level. By providing DC (155 VDC or 270 VDC) to the individual power supplies, the required line-frequency transformers that perform the step-down can be connected in one of various multi-phase configurations, thus reducing harmonic currents. Active filtering is another choice for minimizing harmonic currents.

In the absence of any clear cut advantage for doing otherwise, convert power from 440 VAC in the largest blocks of power practical and consider using the multiphase step-down transformers as part of the approach to control harmonic currents.

115V/200 VAC 400 Hz Power

This power can only be used for services to aircraft, aviation support equipment and aviation units under test. The 3-phase, 4-wire, wye-connected 400 Hz power is intended to be compatible with similar power controlled by MIL-STD-704, the controlling specification for aircraft power.

DC Power

Continuity of power and reduction of harmonic currents caused by rectification of AC voltages are two primary concerns of shipboard electrical power distribution that are best met by providing DC power to using systems. The power supply designer would welcome the change to DC input power because the technology being used to provide high output power densities is based upon DC/DC converter technology. Candidate voltages that are possible DC voltages from both the power system and user's viewpoints are 270 VDC and 155 VDC.

The ship power system designer tends to favor the higher voltage, 270 VDC, because power distribution system losses are minimized. It must be recognized, however, that issues of isolation and safety must be addressed.

DC power eliminates the 3% harmonic current constraints and its impact on output power density. As a function of how the DC is developed, the harmonic current problem may have just been moved to another location and may have to be addressed wherever the conversion takes place. There is growing interest in providing a standard DC voltage on ships.

Aircraft

Electrical Power

MIL-STD-704 establishes requirements for electrical power characteristics on aircraft at the interface between the electrical power system and the user equipment.

AC Power

The standard AC power is a 400 Hz, 115/200 VAC, 4-wire, 3-phase, wye-connected system with the neutral of the wye grounded. Loads greater than 0.5 kVA must use 3-phase power. Single-phase loads must be connected line-to-neutral.

The only alternative, when specifically authorized, is 230/400 VAC with the amplitude requirements proportional to the 115/200 VAC limits.

DC Power

The standard DC power is 28 VDC. An alternate is 270 VDC. This is the nominal DC voltage obtained when the standard 200 VAC, 3-phase, line-to-line aircraft voltage is bridge rectified. Studies have shown major overall advantages for aircraft using 270 VDC as the primary aircraft power. For this reason, a large share of the Navy exploratory and advanced development funds for aircraft electrical power system development in recent years has been spent in developing the components necessary for a 270 VDC system.

APPENDIX D

Fortunately, power supplies can be developed for 3-phase, 115/200 VAC input power that can be directly used on 270 VDC with no modification. If initially considered, these dual-input power supplies have minimal impact on the size, weight, cost and other attributes when compared to power supplies that are only designed for 3-phase, 115/200 VAC input.

Trade-Offs

Single-Platform

The trade-offs for equipment for single-platform use are relatively simple. The shipboard choice indicated by a formal trade-off study almost always results in the use of 60 Hz, 3-phase power at either 115 VAC or 440 VAC, the latter being centrally transformed to 115 VAC or some DC voltage, such as 155 VDC. This is the voltage obtained from line rectification of 3-phase 115 VAC.

The aircraft choice indicated by a formal trade-off study almost always results in 400 Hz, 3-phase power, at 115/200 VAC with consideration given to future 270 VDC operation, since the extra cost in system trade-off penalties is usually insignificant.

Multiple-Platform

Recent attempts to specify equipment for multiple-platform operation have led to input power specifications for a single equipment that have specified five, or six input electrical interfaces. This places a burden on the power supply that makes it difficult, if not possible, to meet the primary objective of this guideline, i.e., reliable power supplies, while striving to meet other needs such as increased output power density.

Trade-off studies seeking the best approach for multiple-platform use of an equipment or system are not straightforward.

Current power supply technology is based on DC/DC converter techniques that use an internal switching frequency dependent on the current state of component and circuit technology. This internal frequency is usually hundreds of kilohertz. Since DC/DC converters require a DC input, the easiest way to obtain this DC is by line rectification of 3-phase power (direct rectification of the AC line voltages with no isolation). This eliminates the size and weight of line-frequency transformers from the power supply.

Direct line rectification of shipboard 3-phase, 440 VAC results in approximately 590 to 600 VDC. This is typically too high for most power supply designs.

Direct line rectification of shipboard 3-phase, 115 VAC results in approximately 155 VDC. This is the logical DC voltage for shipboard use and is highly compatible with existing and developing component and circuit technology. Direct line rectification of shipboard 3-phase, AC power, however, can create excessive current harmonics on the AC bus. There is a need to ensure that appropriate means for meeting the 3% harmonic requirement of MIL-STD-1399 Section 300 are provided. A technique becoming widely used today uses power factor correction

rectification which uses a boost circuit. This circuit can meet the 3% harmonic but puts out a higher output voltage. There is a patented technique that combines this circuit with a high frequency transformer and provides both isolation and a lower output voltage tailored to any reasonable output voltage.

Direct rectification of aircraft 3-phase, 115/200 VAC results in approximately 270 VDC. This is the logical DC voltage for aircraft use. A couple of issues here are personnel safety and a reliable means of disconnect in the event of a fault. Since DC does not go through zero as does AC, it is considerably more difficult to affect a reliable disconnect.

The difficulty of designing to a 1.74 ratio between line rectification of aircraft and shipboard standard AC voltages, when added to the additional spread due to tolerances and transients on aircraft and shipboard power, is one factor in considering the best power supply architecture. How to meet the 3% harmonic current specification for shipboard applications is another factor. Selecting the best multiple platform power supply architecture is a fairly complex task and beyond the scope of these guidelines. As noted above, this is being achieved more and more today through the use of a power factor correction rectification scheme.

APPENDIX E

Parts Derating Tables

COMPONENT DERATING GUIDELINES

Component Type	Derating Parameter	Derated to % Rating (or absolute value as indicated)
Resistors		
Film, Chip	Power	50%
	Voltage	80%
Film, GP (RNR, RLR)	Power	50%
	Voltage	80%
Film, Power	Power	50%
	Voltage	80%
Film, Network	Power	50%
	Voltage	80%
Wirewound, Accurate MIL-R-39005 (RBR)	Power	50%
	Voltage	80%
All others	Power	50%
	Voltage	80%
Wirewound, Power	Power	50%
	Voltage	80%
Wirewound, Chassis mounted	Power	50%
	Voltage	80%
Variable, Wirewound	Power	50%
	Voltage	80%
Variable, Non-wirewound	Power	50%
	Voltage	80%
Thermistor	Power	50%
	Voltage	80%
Capacitors		
All types	Ripple Voltage	50%
All types	Ripple Current	70%

APPENDIX E

All types	Core Temperature	20°C less than rated
Paper, Film	Voltage	55%
Plastic, Film	Voltage	55%
Metalized Film	Voltage	55%
Mica, conventional	Voltage	70%
Mica, Button	Voltage	55%
Glass	Voltage	60%
Ceramic, General Purpose	Voltage	60%
Ceramic, Temp. Comp	Voltage	60%
Ceramic, Chip	Voltage	60%
Tantalum, Solid	Voltage	60%
Tantalum, Non-solid/wet	Voltage	60%
Aluminum	Voltage	70% (Resin/Epoxy end-seal protected)
Gas or Vacuum	Voltage	60%
Variable, Ceramic	Voltage	60%
Variable, Piston	Voltage	60%
Variable, Air Trimmer	Voltage	60%
Magnetic Devices		
Transformers, Inductors	Hot spot temperature	30°C Below Specified Maximum Insulation Rating
	Peak Flux Density	70% of Saturation (for linear magnetics only)

Component Type	Derating Parameter	Derated to % Rating (or absolute value as indicated)
Diodes		
General Purpose, axial lead, small signal/switching	Forward Current (I_F)	70%
	Reverse Voltage (V_R)	70%
	Surge Current (I_{FSM})	60%
	Max T_j ($^{\circ}C$)	110 $^{\circ}C$
Schottky	Power Dissipation (P_D)	70%
	Forward Current (I_F)	70%
	Reverse Voltage (V_R)	70%
	Max T_j ($^{\circ}C$)	110 $^{\circ}C$
Power Rectifier	Forward Current (I_F)	65%
	Reverse Voltage (V_R)	65%
	Max T_j ($^{\circ}C$)	110 $^{\circ}C$
Voltage Regulator/Reference	Power Dissipation (P_D)	70%
	Max T_j ($^{\circ}C$)	110 $^{\circ}C$
Transient Voltage Suppressor	Power Dissipation (P_D)	70%
	Average Current (I_O)	75%
	Max T_j ($^{\circ}C$)	110 $^{\circ}C$
Thyristor	On-State Current (I_T)	70%
	Off-State Voltage (V_{DM})	70%
	Max T_j ($^{\circ}C$)	110 $^{\circ}C$
Transistors		
Bipolar	Power Dissipation (P_D)	65%

APPENDIX E

	Breakdown Voltage (V_{BR})	70%
	Safe Operating Area (SOA) V_{CE}	70%
	Safe Operating Area (SOA) (I_C)	60%
	Max T_j ($^{\circ}C$)	110 $^{\circ}C$
FET	Power Dissipation (P_D)	65%
	Breakdown Voltage (V_{BR})	70%
	Max T_j ($^{\circ}C$)	110 $^{\circ}C$
Optoelectronics		
Photoemitters (LEDs) and Photodetectors	Forward Current (I_F)	65%
	Max T_j ($^{\circ}C$)	110 $^{\circ}C$
Digital Microcircuits		
Hermetic	Supply Voltage	Less than manufacturer's rating
	Max T_j ($^{\circ}C$)	110 $^{\circ}C$
	Fanout	80%
Linear Microcircuits		
	Max T_j ($^{\circ}C$)	110 $^{\circ}C$
	Voltage (Signal)	75%
	Output (Surge)	80%
	Voltage, Reverse Junction (Signal)	65%
	Voltage, Reverse Junction (Surge)	85%
	Current (Continuous)	70%
	Current (Surge)	60%

APPENDIX E

Component Type	Derating Parameter	Derated to % Rating (or absolute value as indicated)
Connectors		
	Current	60%
	Voltage between contacts	25% of max rated dielectric withstanding voltage
	Temperature	60°C below max rated
Relays		
	Current, Continuous, Resistive load	60%
	Current, Continuous, Capacitive load	60%
	Current, Continuous, Inductive load	40%
	Current, Continuous, Motor load	20%
	Current, Continuous, Filament (lamp) load	10%
	Coil Energize Voltage	110%, Max
	Coil Dropout Voltage	90%, Min
	Ambient Temperature	20°C of Max Rated
Switches		
	Current, Continuous, Resistive load	60%
	Current, Continuous, Capacitive load	60%
	Current, Continuous, Inductive load	40%
	Current, Continuous, Motor load	20%
	Current, Continuous, Filament (lamp) load	10%
	Contact Power	60%
	Contact Current (Surge)	80%

APPENDIX F

Glossary

AC source – a voltage/current that periodically changes polarity and is used as the input prime power for a power system. The AC source is typically provided to the weapon system by central platform alternator. An AC source may also be the output of an inverter, frequency changer or uninterruptable power supply.

Ambient temperature - the local temperature existing prior to any influence or change brought about by a dissipative device or apparatus.

Ampacity - the current handling capacity of a conductor expressed in amperes.

Amplifier - a circuit, component or apparatus that provides gain (as to amplify).

Apparent power - the value obtained by the product of rms voltage times the rms current in an AC circuit but which is not necessarily equal to the work (power) because of phase displacement.

Arc – an electrical discharge or series of discharges between two electrodes.

Auto-transformer - a transformer having a single winding without primary to secondary isolation.

Backfeeding – a situation whereby a regenerative load may cause energy or current to flow back into the output of a power conditioner and is usually undesirable.

Balun - meaning balanced/unbalanced (as in a choke or transformer) for matching or separating coupling impedances (common-mode vs differential-mode).

Bandwidth – the breadth of a set or band of frequencies bounded by an upper and lower limit.

Bead - a small magnetic core used as a high frequency attenuator that dissipates unwanted energy as heat.

Bleeder resistor - a resistor used to discharge a capacitor or to constitute a minimal load on a power supply.

Brownout - a voltage just below normal deviations that may cause degraded mode performance and which may also be harmful to electrical equipment.

Built-In-Test-Equipment (BITE) – internal circuitry that constitutes integrated or onboard diagnostic function(s) to facilitate real-time status reporting of the power supply's performance/temperature and other attributes.

Bulk power conversion – a central point of power conditioning with the output voltage forming an intermediate bus, which may be either AC or DC.

Bus - usually a robust common conductor of power to distribute high currents with minimal losses and having low impedance to dynamic currents.

Capacitive reactance (X_c) - an opposition to the changing of a voltage across a capacitor through current movement into/out-of the capacitor.

Center-tap - a connection to an intermediate winding of a transformer or inductor for voltage granularity.

Choke - an inductor used to impede currents of different frequencies as in filters and attenuators.

Closed loop gain - the ratio of magnitude (usually in voltage) between the output of an amplifier and its input, sometimes expressed as A_v or in dB.

Cold plate – the surface on which a component or assembly is placed to transfer heat.

Common mode output current - the equal and coincident current that flows on both output leads of a power supply and is returned to its source via the chassis or frame of the unit.

Comparator - an amplifier used to compare one voltage to another for purposes of deciding an action (i.e., whether to go into over-voltage or over-current or to issue a power-on-reset to logic).

APPENDIX F

Complementary tracking - an interconnection between two voltages or supplies which causes them to maintain a proportional but opposing relationship in the magnitude of their outputs from zero through their final value.

Constant current supply - a power supply that acts to maintain a specific output current into any load resistance or voltage through an internal gain compensated control servo.

Copper loss - the amount of power lost as heat in transformer windings or other conductors in motors/generators, which is sometimes stated as I^2R losses.

Corona - a luminous discharge of electricity due to the ionization of air which appears on the surface of a conductor when the potential gradient exceeds the ionic breakdown voltage.

Creepage distance - the separation between two conductors which, at a given density and pressure, may cause current to begin to flow at a specific voltage which may form an arc plasma.

Crest factor - the relationship between the peak voltage or current and the rms value as a ratio used in determining the utilization power factor of an AC energy source.

Cross coupling - an intentional linkage between independent elements to coordinate regulation or proportional tracking or sequencing of two or more outputs.

Cross regulation - the interrelational reaction of the load changing on one output of a multiple output power supply and its influence upon the voltage of a companion's output.

Crowbar - a transistor or thyristor used to pull-down and clamp the output of a power supply to approximately zero volts to avoid damage to load components/equipments in the event of the output rising beyond their safe operating limit.

Current limiting - a technique of various configurations, which provide protection from damage to the power supply from load shorts or excessively large loads (e.g., foldback, constant power)

Current sharing - a technique by which multiple power supplies are connected in parallel or in a redundancy scheme which promotes proportional sharing of the load across all current providing elements of the power system. The employment can be through passive adjustment or by cross-coupling active circuits integral to each control servo.

Delta - a three phase three wire AC energy source used throughout electrical distribution systems and often used in shipboard applications to minimize the amount of return current flowing in the hull.

Derating - the practice of applying components at lower than their maximum rating (e.g., voltage, current, or temperature) to reduce stress and provide design margins to increase reliability and operating life.

Dielectric - an insulating (non-conductive) medium separating two or more conductors.

Diode Steering - a technique employing rectifiers or diodes to cause current to flow in the desired circuit or direction while blocking it from an undesired path or circuit.

Distortion - an undesirable modification of a waveshape (usually sinusoidal) by non-linear effects/elements resulting in poor or inefficient operation.

Droop - a decrease in voltage or current, typically of short duration, caused by an increase in the current flowing in the source impedance.

Droop regulation - a form of automatic load sharing among multiple, parallel, power supplies.

Efficiency - the ratio of output power divided by the input power, which determines the amount of heat, dissipated by the conversion apparatus (e.g., 80 Watts/100 Watts = 80% efficiency or 20 Watts dissipation).

Electromagnetic Interference/Electromagnetic Compatibility (EMI/EMC) - relates to the emissions made by one electrical apparatus and the effect that those conducted or radiated energies have upon itself and others sharing the same power source or environmental space.

EMI filter - a device usually made of passive components which is used in conjunction with a power supply/system to attenuate the electrical emissions generated by its operation. The EMI filter must be designed to be compatible with its associated energy source and conversion equipment.

Encapsulation - a protective coating or potting placed around electronic components or assemblies to stabilize and/or insulate them.

Excitation current - the current flowing in the winding of a magnetic component (e.g., transformer or inductor) which establishes the magnetic flux lines associated with local magnetization.

Faraday shield/cage - an electrostatic barrier (e.g., metallic screen/foil) to isolate the effects of one circuit or element on another (e.g., between the primary and secondary windings of a transformer).

Fault response - that period of time taken for recognition and reaction to an undesirable connection in an electrical distribution system (e.g., shorts or unintentional grounding).

Fault tolerance - a circuit design technique used to assure the failure of one redundant or paralleled function does not cause failure or inhibit the proper operation of the remaining good element(s) or circuit(s).

Free wheeling diode - the rectifier used to commutate the energy stored in the inductor of an output filter during the "OFF" time.

Frequency changer - an electronic or rotating equipment used to convert one AC source of a given frequency to a source of a different AC frequency (e.g., 60 Hz to 400 Hz).

Gain margin - the amplitude ratio of input signal to return signal in a closed-loop feedback system at the frequency where the signals are in phase and is usually expressed in dB. This is a measure of feedback loop stability.

Glass transition temperature - the temperature at which a polymer or resinous organic substance experiences a significant change in the slope of its coefficient of thermal expansion (CTE) causing mismatches between dissimilar materials (e.g., the shear and "Z" dimensional stress resulting at a plated through hole (e.g., via on an epoxy glass multi-layered circuit board).

Glitch - a slang word or expression used by many to describe a switching transient or unwanted event.

Green wire ground - a non-current conducting wire used to electrically reference equipments and to provide a path for fault currents for protection of personnel and property.

Ground - an electrical connection to which all currents eventually flow to satisfy the laws of a "complete circuit" where the algebraic sum must equal zero.

High Density Module - a power supply module, which is usually encapsulated in plastic or epoxy and is a relatively inexpensive building block from which a power system can be assembled. Sometimes an EMI filter and an intermediate voltage (line conditioner) are necessary to complete the power system function.

High line - the highest input voltage specified for safe operation of a power supply or power system.

APPENDIX F

Highly Accelerated Life Testing (HALT) - a process by which a power supply is operated and tested beyond its normal operational/environmental limits to stimulate the failure of marginal components or functions.

Highly Accelerated Stress Screening (HASS) - a process to identify/detect workmanship flaws, latent defects, and marginal designs.

High Voltage Power Supply - a supply whose output is in excess of 300 volts.

Hold-Up time - the period or length of time that electronic equipment will continue to operate on internally/locally stored energy when the prime source of power is removed (usually milliseconds).

Hot swappable - a system design technique or circuit type which facilitates the removal/replacement of modules or component elements while the system is powered.

Impedance - the opposition to flow of an alternating current resulting from resistance and reactance in a conductor or component. The reactance changes in magnitude with frequency.

Inrush current - the instantaneous current drawn by an electrical device at the closing of its switch or at the initial application of power (can be 10X or more the normal operating current).

Insulation/Isolation resistance - the resistance between various parts or parts to ground; or between terminals or terminals to ground; or between groups of parts and terminals or groups of parts/terminals to ground. This is usually specified in ohms at a given voltage and frequency and is typically much greater than 1 megOhm.

Inverter - an electrical equipment (usually electronic) which is employed to change one form of electrical energy into a form suitable for a particular/peculiar application within a large system.

Joule - a unit of work energy defined as a watt-second or the product of power times time.

Kelvin connection - a four terminal circuit by which the current carrying conductors are isolated from the voltage measurement terminals to assure accurate measurements of resistance or temperature.

Line regulation - the ability of a power regulator to maintain its output voltage within specified narrow limits with significant changes in the magnitude of the input voltage (typically +/-10% or greater).

Load regulation - a process whereby the output voltage or current is maintained within specified limits as output load is varied. This may be specified as static or dynamic regulation.

Load sharing - design techniques whereby multiple power supplies operating in parallel each supply a share of the load.

Logic Enable/Inhibit - a TTL/CMOS compatible signal interface to a power supply which can be used to turn it on or off (sometimes called "remote on/off").

Loop stability - a figure of merit usually given in terms of phase and gain margins which establish the way to which a control servo responds to line and load steps.

Low line - the lowest steady-state input voltage for the operation of a power supply or power system to remain in specification.

Metal Oxide Varistor (MOV) - usually a zinc oxide pile component having a non-linear dynamic resistance with voltage, used as a suppression device to protect against line voltage transients.

Motor Generator - an equipment employed to convert one frequency or type of energy into another to meet a specific requirement. It can be AC or DC on either side of the conversion and typically the motor and generator share a common shaft.

Noise - is normally an unwanted byproduct of the switching of electrical currents or the result of electromagnetic energy in the environment. It is usually random but can be synchronous.

N + M - a redundancy technique whereby an extra element(s) is continuously on-line to become a real-time replacement if one of the elements constituting N should fail.

Open circuit voltage - the potential appearing across the output when no current is being drawn.

Output impedance - the impedance (magnitude and phase versus frequency) when looking back into the circuit. For a change in load current, there will be a predictable, corresponding change in voltage at a given frequency.

Overcurrent protection – circuitry within a power supply that limits the maximum output current to a specified magnitude.

Overshoot - usually an unwanted result of the sudden unloading of a current source (i.e., the output of a power supply, which has an inductor as a part of its output filter). Normally a voltage transient.

Periodic And Random Deviation (PARD) – deviation about the mean, which is the composite peak-to-peak envelope of ripple and noise which exists on the output of a power conversion equipment.

Phase margin – the open loop difference in phase between an input signal and the corresponding return signal in a closed-loop feedback system at the frequency where the amplitude difference is zero. The phase margin is usually expressed in degrees and is one measure of feedback loop stability.

Phasors - a vectorial descriptor of the angular displacement between the voltage and current in a circuit and usually has to do with phase margins or power factor as it relates to power or power supplies.

Platform power - that power provided to systems or subsystems by the vehicle/ship/aircraft/satellite upon which it is installed.

Point-of-Load – a collocated deployment technique of distributed post regulators which provide a dedicated regulated output(s) to individual functional elements or components of a system or subsystem.

Power On Reset (POR) - a power supply signal indicating that its output(s) are in tolerance and used for the initialization of logic in the next higher assembly.

Post regulator - a circuit or control element located after or down-stream of the primary conditioning of energy to provide particularly well regulated or quiet (low noise) current to sensitive loads.

Power - the product of in-phase voltage and current in a device or (for resistive devices) the product of the square of the current times the resistance through which the current is flowing. Power is expressed in watts.

Power factor - a unit of measure, usually given in decimal, which is the ratio of active power in Watts to the apparent power in VA (rms voltage times rms current).

Power supply - an apparatus that has as its input raw and unregulated voltage which it conditions, steps up or down, and regulates for use by electrical loads.

Power System – the entire collection of equipments and distribution medium which conditions and carries the energy from the prime source to the utilizing loads.

Prime power - that power source from which all of the platform power is derived (i.e., the prime source).

APPENDIX F

Pulse Width Modulator (PWM) – a device that takes analog signals and generates electrical pulses of controlled width.

Radio Frequency Interference (RFI) - see EMI in this glossary.

Rectifier - an element or component that allows current to flow in but one direction, usually used for changing an AC source into a DC source.

Reference- a standard cell or component quantity which establishes the standard to which something else (e.g., output voltage) is regulated.

Regulation - the control process of an output voltage or current which maintains it within predetermined bounds while other parametrics are changing (e.g., temperature/load/line/aging/radiation).

Remote sense - the carrying of the point of regulation to a distance beyond the output of a power supply to include error correction associated with voltage drops in the distribution.

Ripple -that portion of an AC component residing upon a DC output voltage.

Secondary input power - usually an alternative energy source from which a system can be powered when the prime source is unavailable.

Silicon Controlled Rectifier (SCR) - a regenerative semiconductor which, after being gated “on” generally remains turned "on" or “saturated" until the anode current or anode/cathode voltage decays to zero. The anode current must reverse to clear the outer two junctions so the device will regain its forward blocking capability.

Soft start - a circuit technique employed (usually in the front end) of a power conversion apparatus to limit the inrush current at turn on (see inrush in this glossary).

Switching power supply – provides a regulated DC output voltage. The switching/regulating device(s) consists of one or more semiconductors typically driven at a frequency below 1 MHz. The developed square wave is magnetically coupled to the output and rectified/filtered to establish the user voltage. A sample of the output voltage is isolated and fed back to the input to control the ON/OFF period of the switching semiconductors. This feedback control, along with an internal reference, establishes the set point for the output voltage and regulates against both input line and output load perturbations.

Synchronous rectifier - a circuit technique by which a field effect transistor (FET) is substituted for the rectifying diode(s) to facilitate increased rectification efficiencies at low voltages.

Thermal runaway - the condition whereby an increase in a component's or system's temperature will increase its power dissipation, which further increases its temperature. This cycle will continue until failure.

Thyristor – See Silicon Controlled Rectifier in this glossary.

Topology – The configuration of a power supply or power system. As an example, the topology of a power supply may be that of a two transistor half-bridge converter, a full bridge converter, a linear regulator or a ferroresonant magnetic regulator. The topology of a power system may be an architecture that focuses on centralized, decentralized or distributed power conditioning hardware.

Transient - an instantaneous change in voltage or any other parameter, which is outside the normal excursions.

Undershoot - an instantaneous sagging of a voltage caused by a sudden increase in current.

Uninterruptible Power Supply (UPS) – a device which usually contains a battery to provide operational power during short-term degradation of the prime power source.

Voltage multiplier - a diode capacitor circuit configuration used to produce 2, 3 or 4X the output voltage of a pulsed input.

Voltage regulation - a process whereby the output voltage is maintained within specified limits during variations of input power, output load and temperature.

Withstand voltage - the potential that the insulation or isolation resistance can tolerate before breaking down (e.g., transformer insulation or dielectric between isolated components and chassis).

Wye connection - an electrical distribution system employing four conductors, one for each of the three Phases and one for neutral, which is usually depicted as the capital letter "Y" where the intersection of the three legs of the letter is the Neutral connection and the extremities represent phases A, B, and C in a clockwise rotation.

Zener Diode - a PN junction diode forced or broken-down into avalanche (reverse biased) where it establishes a very stable reference voltage having a very low dynamic resistance and which is somewhat insensitive to variations in temperature.