

Naval Facilities Engineering Command
200 Stovall Street
Alexandria, Virginia 22332-2300

APPROVED FOR PUBLIC RELEASE

Blast Resistant Structures

DESIGN MANUAL 2.08
DECEMBER 1986

REPRODUCED AT GOVERNMENT EXPENSE

SN 0525-CP-300-2092

RECORD OF DOCUMENT CHANGES

Instructions: DISCARD EXISTING SHEET AND INSERT THIS NEW RECORD OF DOCUMENT CHANGES.

This is an inventory of all changes made to this design manual. Each change is consecutively numbered, and each changed page in the design manual includes the date of the change which issued it.

Change Number	Description of Change	Date of Change	Page Changed
------------------	--------------------------	-------------------	-----------------

ABSTRACT

This design manual contains information that provides design guidance for structures of various types to resist blast loadings. It is supplementary to NAVFAC P-397 and is intended to consolidate and simplify various sources of design criteria which cover the structural elements encountered in blast resistant design.

The various effects associated with chemical (HE) explosion, the design of structural steel elements, reinforced concrete frame, and other structural elements, such as reinforced masonry and glass, are described. Design and analysis of blast doors and foundations and the description and availability of certain computer programs are also provided.

PAGE iv INTENTIONALLY LEFT BLANK

FOREWARD

This manual is one of a series developed for instruction on the preparation of Navy facilities engineering and design criteria documents. This design manual uses, to the maximum extent feasible, national and institute standards in accordance with Naval Facilities Engineering Command (NAVFACENGCOM) policy. Deviations from these criteria should not be made without prior approval of NAVFACENGCOM Headquarters (Code 04M2).

Recommendations for improvement are encouraged from within the Navy and the private sector and should be furnished to Commanding Officer, Northern Division (Code 04AB), Naval Facilities Engineering Command, Philadelphia, PA 19112-5094

This publication is certified to be an official publication of the Naval Facilities Engineering Command and has been approved in accordance with SECNAVINST 5600.16, Review of Department of the Navy (DN) Publications; Procedures Governing.

J. P. JONES, JR.
Rear Admiral, CEC, U. S. Navy
Commander
Naval Facilities Engineering Command

STRUCTURAL ENGINEERING DESIGN MANUALS

<u>Number</u>	<u>Title</u>
DM-2.01	General Requirements
DM-2.02	Loads
DM-2.03	Steel Structures
DM-2.04	Concrete Structures
DM-2.05	Timber Structures
DM-2.06	Aluminum Structures, Composite Structures, Other Structural Materials
DM-2.07	Seismic Site Response Spectra (Proposed)
DM-2.08	Blast Resistant Structures
DM-2.09	Masonry Structural Design for Buildings[***]

[***] Tri-Service Manual

BLAST RESISTANT STRUCTURES

CONTENTS

	Page
	<u> </u>
SECTION 1 INTRODUCTION.....	2.08-1
1. PURPOSE AND OBJECTIVE.....	2.08-1
a. Purpose.....	2.08-1
b. Objective.....	2.08-1
2. SCOPE.....	2.08-1
a. Topics.....	2.08-1
b. General Theory and Principles.....	2.08-1
3. DESIGN PHILOSOPHY.....	2.08-2
4. CRITERIA FOR PERSONNEL AND MATERIALS.....	2.08-2
a. Safety Requirements.....	2.08-2
b. Criteria and Design.....	2.08-2
c. Reduction of Minimum Safety Distances.....	2.08-2
5. SHORT AND LONG DURATION BLAST LOADS.....	2.08-2
a. Impulse Design.....	2.08-2
b. Pressure Design.....	2.08-3
c. Pressure and Duration Design.....	2.08-3
6. PRIMARY AND SECONDARY FRAGMENTS.....	2.08-3
a. Primary Fragments.....	2.08-3
b. Secondary Fragments.....	2.08-3
7. STRUCTURAL ANALYSIS AND DESIGN.....	2.08-3
a. Principles of Dynamic Analysis.....	2.08-5
b. Methods of Predicting Dynamic Response.....	2.08-6
8. PROTECTION CATEGORIES.....	2.08-10
a. Category 1.....	2.08-10
b. Category 2.....	2.08-10
c. Category 3.....	2.08-10
d. Category 4.....	2.08-11
9. EXAMPLE PROBLEM - Moment Area Method.....	2.08-11
10. NOTATION.....	2.08-13
SECTION 2 EFFECTS OF EXPLOSIONS.....	2.08-15
1. SCOPE AND RELATED CRITERIA.....	2.08-15
a. Scope.....	2.08-15
b. Related Criteria.....	2.08-15
2. SAFETY FACTOR AND ACCURACY.....	2.08-15
a. Simplifications in the Development of Design Procedures.....	2.08-15
b. Modification of Charge Weight.....	2.08-15

	Page
	<u> </u>
3. BLAST PRESSURE OUTPUT.....	2.08-16
a. Blast Phenomena.....	2.08-16
b. TNT Equivalents.....	2.08-16
c. Cased Explosives.....	2.08-16
4. UNCONFINED EXPLOSIONS.....	2.08-18
a. Free-Air Blast.....	2.08-18
b. Surface Burst.....	2.08-18
c. Pressure-Time Variation.....	2.08-18
5. PARTIALLY VENTED EXPLOSIONS.....	2.08-21
a. Definition.....	2.08-21
b. Interior Blast Loading.....	2.08-21
c. Blast Environment Outside Cubicle.....	2.08-24
6. FULLY VENTED EXPLOSIONS.....	2.08-26
a. Definition.....	2.08-26
b. Interior Blast Loadings.....	2.08-29
c. Exterior Blast Environment.....	2.08-29
d. Design Loads.....	2.08-29
7. AIRBLAST FROM UNDERWATER EXPLOSIONS.....	2.08-29
a. Predicting Parameters of a Shock Wave.....	2.08-29
b. Configuration of Charge and Interpretation of Different Parameters.....	2.08-35
8. EXTERNAL BLAST LOADS ON STRUCTURES.....	2.08-35
a. Forces Acting on Structures.....	2.08-35
b. Calculating Durations of Positive and Negative Pressure Phases.....	2.08-35
c. Aboveground Rectangular Structures.....	2.08-35
9. PRESSURE INCREASE WITHIN A STRUCTURE.....	2.08-43
10. MULTIPLE EXPLOSIONS.....	2.08-43
a. Blast Characteristics.....	2.08-43
b. Blast Loading on Side Walls of a Cubicle Due to Simultaneous Explosions.....	2.08-43
11. PRIMARY FRAGMENTS.....	2.08-43
a. Initial Fragment Velocities.....	2.08-43
b. Variation of Fragment Velocity with Distance.....	2.08-44
c. Fragment Mass Distribution.....	2.08-47
12. EXAMPLE PROBLEMS.....	2.08-58
a. Blast Environment Inside Vented Cubicle.....	2.08-58
b. Blast Environment Outside Cubicle.....	2.08-60
c. Airblast from Underwater Explosions.....	2.08-61
d. Primary Fragments from Cased Cylindrical Charges.....	2.08-62

	Page
	<hr/>
13. NOTATION.....	2.08-65
SECTION 3 BEAM AND COLUMNS IN REINFORCED CONCRETE STRUCTURES....	2.08-69
1. INTRODUCTION.....	2.08-69
2. DYNAMIC STRENGTH OF MATERIALS.....	2.08-69
a. Introduction.....	2.08-69
b. Static Design Stresses.....	2.08-70
c. Dynamic Design Stresses.....	2.08-70
3. DYNAMIC DESIGN OF BEAMS.....	2.08-71
a. General.....	2.08-71
b. Ultimate Dynamic Moment Capacity.....	2.08-71
c. Minimum Flexural Reinforcement.....	2.08-73
d. Diagonal Tension.....	2.08-73
e. Direct Shear.....	2.08-74
f. Torsion.....	2.08-75
g. Dynamic Analysis.....	2.08-81
4. DYNAMIC DESIGN OF INTERIOR COLUMNS.....	2.08-90
a. General.....	2.08-90
b. Strength of Compressive Members (P-M Curve)...	2.08-90
c. Slenderness Effects.....	2.08-97
d. Dynamic Analysis.....	2.08-101
e. Design of Tied Columns.....	2.08-101
f. Design of Spiral Columns.....	2.08-103
g. Design for Rebound.....	2.08-104
5. DYNAMIC DESIGN OF EXTERIOR COLUMNS.....	2.08-104
a. Introduction.....	2.08-104
b. Design of Exterior Columns.....	2.08-105
6. EXAMPLE PROBLEMS.....	2.08-105
a. Design of a Beam.....	2.08-105
b. Design of a Beam Subject to Torsion.....	2.08-115
c. Column Design.....	2.08-120
7. NOTATION.....	2.08-124
SECTION 4 STEEL STRUCTURES.....	2.08-129
1. SCOPE AND RELATED CRITERIA.....	2.08-129
a. Scope.....	2.08-129
b. Related Criteria.....	2.08-129
2. RECOMMENDED DESIGN STRESSES.....	2.08-131
a. Structural Steel.....	2.08-131
b. Cold-Formed Steel.....	2.08-131
3. BEAMS AND PLATES.....	2.08-132
a. Beams.....	2.08-132
b. Plates.....	2.08-136

	Page
	<u> </u>
4. COLD-FORMED STEEL ELEMENTS.....	2.08-137
a. Beam Elements.....	2.08-137
b. Panels.....	2.08-137
5. COLUMNS AND BEAM COLUMNS.....	2.08-144
a. Plastic Design Criteria.....	2.08-145
b. Effective Length Ratios for Beam Columns.....	2.08-153
c. Effective Length Factor, K.....	2.08-154
6. FRAME DESIGN.....	2.08-154
a. Introduction.....	2.08-154
b. Single-Story Rigid Frames.....	2.08-156
c. Single-Story Frames with Supplementary Bracing.....	2.08-163
7. CONNECTIONS.....	2.08-169
a. Dynamic Design Stresses for Connections.....	2.08-169
b. Requirements for Panel Connections.....	2.08-169
8. EXAMPLE PROBLEMS.....	2.08-171
a. Design of Beams for Pressure-Time Loading.....	2.08-171
b. Design of Cold-Formed, Light-Gage Steel Panels Subjected to Pressure-Time Loading.....	2.08-176
c. Design of Beam Columns.....	2.08-181
d. Design of Single-Story Rigid Frames for Pressure-Time Loading.....	2.08-184
9. NOTATION.....	2.08-193
SECTION 5 OTHER STRUCTURAL MATERIALS.....	2.08-197
1. MASONRY.....	2.08-197
a. Application.....	2.08-197
b. Design Criteria for Masonry Walls.....	2.08-200
c. Non-Reinforced Masonry Walls.....	2.08-210
2. PRECAST CONCRETE.....	2.08-217
a. Applications.....	2.08-217
b. Static Strength of Materials.....	2.08-217
c. Dynamic Strength of Materials.....	2.08-219
d. Ultimate Strength of Precast Elements.....	2.08-219
e. Dynamic Analysis.....	2.08-223
f. Rebound.....	2.08-224
g. Connections.....	2.08-225
3. GLASS.....	2.08-229
a. Types of Glass.....	2.08-229
b. Properties of Glass.....	2.08-229
c. Recommended Design Criteria.....	2.08-232
d. Recommended Specifications for Blast Resistant Windows.....	2.08-232

	Page
	<u> </u>
4. SPECIAL PROVISIONS FOR PRE-ENGINEERED BUILDINGS...	2.08-236
a. General.....	2.08-236
b. General Layout.....	2.08-236
c. Preparation of Partial Blast Analysis.....	2.08-240
d. Pre-Engineered Building Design.....	2.08-240
e. Blast Evaluation of the Structure.....	2.08-241
f. Recommended Specifications for Pre-Engineered Buildings.....	2.08-241
5. EXAMPLE PROBLEMS.....	2.08-248
a. Masonry Wall Design.....	2.08-248
b. Design of Precast Prestressed Roof.....	2.08-253
6. NOTATION.....	2.08-266
SECTION 6 BLAST DOORS.....	2.08-269
1. SCOPE AND RELATED CRITERIA.....	2.08-269
a. Scope.....	2.08-269
b. Related Criteria.....	2.08-269
2. GENERAL.....	2.08-269
3. DESIGN CONSIDERATIONS.....	2.08-269
4. TYPES OF CONSTRUCTION.....	2.08-269
a. General.....	2.08-269
b. Solid Steel Plate Door.....	2.08-270
c. Built-Up Door.....	2.08-270
5. DOOR FRAME.....	2.08-272
6. EXAMPLE PROBLEMS.....	2.08-272
a. Design of a Solid Steel Door.....	2.08-272
b. Design of a Built-Up Steel Blast Door.....	2.08-280
c. Design of Door Frame.....	2.08-288
7. NOTATION.....	2.08-294
SECTION 7 FOUNDATIONS.....	2.08-297
1. INTRODUCTION.....	2.08-297
a. Conventional Loads.....	2.08-297
b. Blast Loads.....	2.08-297
2. FOUNDATION DESIGN.....	2.08-297
a. Introduction.....	2.08-297
b. Preliminary Design.....	2.08-299
c. Design Criteria.....	2.08-305
3. SOIL-STRUCTURE INTERACTION.....	2.08-307
a. Introduction.....	2.08-307
b. Overturning Design Criteria as Related to Soils Data.....	2.08-307

	Page
4. EXAMPLE PROBLEM - Design of a Simple Type Foundation Extension.....	2.08-311
5. NOTATION.....	2.08-326
SECTION 8 COMPUTER PROGRAMS.....	2.08-329
1. GENERAL.....	2.08-329
a. Finite Element Computer Program.....	2.08-329
b. Additional Computer Programs.....	2.08-329

FIGURES

1	Basic Difference Between Static and Dynamic Loads.....	2.08-4
2	Resistance-Deflection Curve.....	2.08-6
3	Load and Resistance Diagrams.....	2.08-8
4	Acceleration Diagram.....	2.08-8
5	Resistance Function.....	2.08-11
6	Load and Resistance Functions.....	2.08-12
7	Suggested Pressure versus Time (p-T) Curves.....	2.08-20
8	Peak Gas Pressure from a Partially Vented Explosion of TNT in a 4-Wall Cubicle.....	2.08-22
9	Peak Gas Pressure From a Partially Vented Explosion of Composition B in a 4-wall Cubicle.....	2.08-23
10	Scaled Impulse of Gas Pressure Inside a Partially Vented Cubicle.....	2.08-25
11	Design Chart for Vent Area Required to Limit Pressures at Any Range Outside a 4-Wall Cubicle.....	2.08-27
12	Design Chart for Vent Area Required to Limit Positive Impulse at any Range Outside a 4-Wall Cubicle.....	2.08-28
13	Envelope Curves for Peak Positive Pressure Outside 3-Wall Cubicles Without a Roof.....	2.08-30
14	Envelope Curves for Maximum Peak Pressure Outside 3-Wall Cubicles.....	2.08-31
15	Envelope Curves for Peak Positive Pressure Outside 3-Wall Cubicles With a Roof.....	2.08-32
16	Proposed Criteria for Design Loading Inside Fully and Partially Vented Cubicles.....	2.08-33
17	Proposed Criteria for Design Loading Outside Fully and Partially Vented Cubicles.....	2.08-34
18	Charge Configuration.....	2.08-36
19	Airblast From Underwater Explosions, [math>\lambda] Fixed at 0.25.....	2.08-37
20	Airblast From Underwater Explosions, [math>\lambda] Fixed at 1.....	2.08-38
21	Airblast From Underwater Explosions, [math>\lambda] Fixed at 3.....	2.08-39
22	Airblast From Underwater Explosions, [math>\lambda] Fixed at 10.....	2.08-40
23	Airblast From Underwater Explosions, [math>\lambda] Fixed at 20.....	2.08-41

	Page	
24	Airblast From Underwater Explosions, [λ] γ Fixed at 40.....	2.08-42
25	Initial Velocity of Primary Fragments for Cylindrical Casing.....	2.08-46
26	Variation of Primary Fragment Velocity with Distance.....	2.08-48
27	Fragment Weight Distribution Relationships.....	2.08-51
28	Probability Distribution Function of Fragment Weights....	2.08-53
29	M_A/B vs. Casing Geometry.....	2.08-54
30	Design Fragment Weight vs. Design Confidence Level (0.3 to 1.0).....	2.08-55
31	Design Fragment Weight vs. Design Confidence Level (0.986 to 1.0).....	2.08-56
32	$B^2/N_T/C$ vs. Casing Geometry.....	2.08-57
33	Arrangement of Reinforcement for Combined Flexure and Torsion.....	2.08-79
34	Resistance - Deflection Functions for Beams.....	2.08-82
35	Column Interaction Diagram.....	2.08-91
36	Typical Interior Column Sections.....	2.08-94
37	Coefficient for Moment of Inertia of Cracked Section with Equal Reinforcement on Opposite Faces.....	2.08-100
38	Design of Beam in Flexure.....	2.08-107
39	Design of Beam in Torsion.....	2.08-120
40	Concrete Column Section.....	2.08-122
41	Elastic Rebound of Single-Degree-of-Freedom System.....	2.08-139
42	Allowable Dynamic (Design) Shear Stresses for Webs of Cold Formed Members ($F_y = 40$ ksi).....	2.08-141
43	Maximum End Support Reaction for Cold-Formed Steel Sections, $F_y = 40$ ksi (275.8 MPa).....	2.08-146
44	Maximum Interior Support Reaction for Cold-Formed Steel Sections, $F_y = 40$ ksi (275.8 MPa).....	2.08-147
45	Estimates of Peak Shears and Axial Loads in Rigid Frames Due to Horizontal Loads.....	2.08-160
46	Estimates of Peak Shears and Axial Loads in Braced Frames Due to Horizontal Loads.....	2.08-167
47	Typical Connections for Cold-Formed Steel Panels.....	2.08-170
48	Beam Configuration and Loading.....	2.08-173
49	Pressure Loading and Roof Decking Configuration.....	2.08-178
50	Preliminary Design of Four-Bay, Single-Story Rigid Frame.....	2.08-187
51	Masonry Wall with Flexible Support.....	2.08-198
52	Masonry Wall with Rigid Support.....	2.08-199
53	Concrete Masonry Walls.....	2.08-201
54	Typical Joint Reinforced Masonry Construction.....	2.08-202
55	Reinforced vs Non-Reinforced Masonry Construction.....	2.08-203
56	Typical Concrete Masonry Units.....	2.08-204
57	Connection Details for Rebound and Negative Overpressures.....	2.08-212
58	Deflection of Non-Reinforced Masonry Walls.....	2.08-213
59	Structural Behavior of Non-Reinforced Solid Masonry Panel with Rigid Supports.....	2.08-216
60	Common Precast Elements.....	2.08-218
61	Typical Stress-Strain Curve for High Strength Wire.....	2.08-220

	Page
62	Typical Building Cross Section..... 2.08-227
63	Typical Wall Panel-to-Roof Slab Connection..... 2.08-228
64	Wall Panel-to-Foundation Connection..... 2.08-230
65	Typical Panel Splice..... 2.08-231
66	Critical Shatter Pressure vs. Pane Thickness for Plexiglas..... 2.08-233
67a	Recommended Pre-engineered Building Design Loads..... 2.08-237
67b	Recommended Pre-engineered Building Design Loads (continued)..... 2.08-238
68	Example Problem for Design of Masonry Wall..... 2.08-250
69	Design of Prestressed Precast Roof..... 2.08-255
70	Required Reinforcement for Blast Load..... 2.08-265
71	Steel Plate Blast Door..... 2.08-271
72	Built-Up Steel Blast Door..... 2.08-273
73	Double Leaf Blast Door Installed in a Concrete Structure..... 2.08-274
74	Pressure Loading and Door Configuration, Example 6a..... 2.08-276
75	Door Plate Hinged on Opposite Sides..... 2.08-279
76	Pressure Loading and Door Configuration, Example 6b..... 2.08-282
77	Built-Up Cross-Section..... 2.08-285
78	Cross-Section of Blast Door..... 2.08-289
79	Location of Yield Lines on Door Plate..... 2.08-290
80	Details of Stiffener Plate..... 2.08-291
81	Configuration of Anchor Bars..... 2.08-293
82	Changes in Distribution of Loading On Foundation..... 2.08-298
83	Cantilever Wall Barrier..... 2.08-300
84	Two-Wall Barrier..... 2.08-301
85	Multi-Cell Barricade..... 2.08-302
86	Cantilever Wall Barrier - Estimated Foundation Dimensions..... 2.08-303
87	Single Cell Barrier - Estimated Foundation Dimensions.... 2.08-304
88	Displaced Configuration of Structure at Incipient Overturning..... 2.08-309
89	Definition of Overturning Angle..... 2.08-310
90	Design Parameters - Simple Type Foundation..... 2.08-314
91	Free Body Diagrams of Simple Type Foundation Extension for Computation of Peak Shear and Bending Moment..... 2.08-315
92	Dimensions of Structure, Design Details of Backwall and Charge Locations..... 2.08-317
93	Locations of Critical Sections of Foundation Extension for Shear and Bending..... 2.08-321
94	Foundation Extension Design Loadings..... 2.08-323

TABLES

1	TNT Pressure Equivalences..... 2.08-17
2	Initial Velocity of Primary Fragments..... 2.08-46
3	Explosive Constants..... 2.08-49
4	Design Fragment Weights for Various Design Confidence Levels..... 2.08-58
5	Ultimate Unit Resistances for Beams..... 2.08-83

	Page
	<hr/>
6	Elastic and Elasto-Plastic Unit Resistances for Beams.... 2.08-84
7	Elastic, Elasto-Plastic, and Equivalent Elastic Stiffnesses for Beams..... 2.08-85
8	General and Ultimate Deflections for Beams..... 2.08-86
9	Support Shears for Beams..... 2.08-87
10	Transformation Factors for Beams..... 2.08-89
11	Dynamic Increase Factor, c 2.08-131
12	Dynamic Design Shear Stress for Webs of Cold-Formed Members ($F_y = 40$ ksi)..... 2.08-142
13	Dynamic Design Shear Stress for Webs of Cold-Formed Members ($F_y = 60$ ksi)..... 2.08-143
14	Dynamic Design Shear Stress for Webs of Cold-Formed Members ($F_y = 80$ ksi)..... 2.08-144
15	Maximum End Support Reaction for Cold-Formed Steel Sections ($F_y = 60$ ksi)..... 2.08-148
16	Maximum Interior Support Reaction for Cold-Formed Steel Sections ($F_y = 60$ ksi)..... 2.08-149
17	Maximum End Support Reaction for Cold-Formed Steel Sections ($F_y = 80$ ksi)..... 2.08-150
18	Maximum Interior Support Reaction for Cold-Formed Steel Sections ($F_y = 80$ ksi)..... 2.08-151
19	Effective Length Ratios for Beam Columns (Bending About the Strong Axis)..... 2.08-153
20	Effective Length Ratios for Beam Columns (Bending About the Weak Axis)..... 2.08-154
21	Effective Length Factors for Columns and Beam-Columns..... 2.08-155
22	Collapse Mechanisms for Rigid Frames with Fixed and Pinned Bases..... 2.08-157
23	Dynamic Load Factors (DLF) and Equivalent Static Loads for Trial Design..... 2.08-158
24	Stiffness Factors for Single Story, Multi-Bay Rigid Frame Subjected to Uniform Horizontal Loading..... 2.08-161
25	Collapse Mechanism for Rigid Frames with Supplementary Bracing and Pinned Bases..... 2.08-164
26	Collapse Mechanisms for Frames with Supplementary Bracing Non-Rigid Girder to Column Connections and Pinned Bases..... 2.08-165
27	Properties of Hollow Masonry Units..... 2.08-205
28	Deflection Criteria for Masonry Walls..... 2.08-209
29	Moment of Inertia of Masonry Walls..... 2.08-211
30	Recommended Design Criteria for Maximum Blast Pressure Capacity for Glass Mounted in Rigid Window Frames..... 2.08-234
31	Minimum Area of Flexural Reinforcement..... 2.08-306
32	Soil Properties - Non-Cohesive Soils..... 2.08-308
33	Soil Properties - Cohesive Soils..... 2.08-308
34	Capabilities of Computer Programs..... 2.08-330
	BIBLIOGRAPHY 2.08-335
	REFERENCES 2.08-337

SECTION 1. INTRODUCTION

1. PURPOSE AND OBJECTIVE. The purpose and objective of this manual is as follows:

a. Purpose. This manual, which is a new one in the structural engineering design series, is to provide design guidance for structures of various types to resist blast loadings. Information in this manual is the result of extensive literature and data search, supplemented by some original studies on various aspects of blast design. Existing design criteria are reviewed, consolidated and simplified where appropriate.

b. Objective. This manual is supplementary to NAVFAC P-397, Structures to Resist the Effects of Accidental Explosions of June 1969, and is intended to assist engineers in the preparation of design using established criteria. NAVFAC P-397 is currently being revised. In the event of any contradiction between the new P-397 and this manual, the new edition of P-397 will govern.

2. SCOPE.

a. Topics. The topics covered in this manual include:

1. Clarification of the differences between static and dynamic loadings, and between short and long duration dynamic loads.

2. Various effects associated with a chemical (HE) explosion including blast overpressures, fragments from casing and secondary fragments associated with the break-up of a donor structure.

3. Design of reinforced concrete beams and columns.

4. Design of structural steel elements to withstand blast loads.

5. Design of blast resistant elements using materials other than cast-in-place reinforced concrete and structural steel. Such materials include reinforced concrete masonry, brick, glass, and similar transparent materials.

6. Design and analysis procedures for blast doors.

7. Design and analysis of foundations including the dynamic increase factor for soil strength.

8. Description of available programs used in the design of blast resistant structures.

b. General Theory and Principles. Wherever warranted, general theory and principles are provided. It should be emphasized that the manual is not intended to develop new material beyond the present "state-of-the-art", but rather to consolidate and simplify existing criteria in NAVFAC P-397, and also to "bring together" the various sources of design criteria which cover the structures encountered in blast resistant design.

3. DESIGN PHILOSOPHY. In the design of facilities for the manufacture or storage of explosive materials, the designer is concerned with maintaining a cost effective design and at the same time, directing his efforts towards reducing the risk of injury to people and damage to property from accidental explosions. The trade-off between risk reduction and safety costs can be balanced reasonably by enforcing the minimum design requirements provided in this and similar design manuals. The design engineer needs a working knowledge of these manuals to design and construct safe economical facilities which comply with explosives safety standards. Several examples are provided in this manual as an effort to satisfy this need.

4. CRITERIA FOR PERSONNEL AND MATERIALS. In the event of an accident, personnel and material are exposed to hazards such as blast fragmentation and debris. Present hazard classification of mass detonating ordnance during manufacturing, transportation and storage is based on quantity-distance standards which relate the net weight of explosive to safe stand-off distances for personnel and buildings.

a. Safety Requirements. Principal documents which prescribe the minimum safety requirements and proximity of explosive storage and handling facilities to each other, to inhabited buildings and the like, are:

- (1) NAVFAC P-397, Structures to Resist the Effects of Accidental Explosions.
- (2) AMCR 385-100, Safety Manual.
- (3) DOD Manual 6055.9-STP, Ammunition and Explosives Safety Standards.
- (4) DOD Manual 4145.26, Contractors' Safety Manual for Ammunition and Explosives

b. Criteria and Design. NAVFAC P-397 establishes criteria for design of structures to be resistant to explosions. AMCR 385-100 and DOD Manuals 6055.9-STD and 4125.26 prescribe safe methods and practices for safeguarding personnel, insuring continuity of production, and preventing property damage.

c. Reduction of Minimum Safety Distances. It should be stated, however, that if it can be verified through tests or conservative analysis that the blast pressures and fragments resulting from an explosion can be completely contained, then the required minimum safety distances can be reduced significantly.

5. SHORT AND LONG DURATION BLAST LOADS. The response of a structure to blast loads depends on its location relative to the source of the explosions. This response is expressed in terms of pressure ranges; namely, high, intermediate, and low pressure ranges.

a. Impulse Design. When the initial pressures acting on a structure are high and the durations short, compared to the response time of the structure, then it has to be designed for the impulse (area under curve) rather than for the peak pressure. The design of structures that respond to impulse loads is presented in detail in NAVFAC P-397.

b. Pressure Design. Durations of blast loads acting on structures designed for a low pressure range are extremely long in comparison to impulse (short duration) loads. Here, the structure responds to the peak pressure.

c. Pressure and Duration Design. Structures subjected to pressures in the intermediate range are designed to respond to the combined effects of both the pressure and impulse associated with the blast output.

6. PRIMARY AND SECONDARY FRAGMENTS. The distinction between primary and secondary fragments is as follows:

a. Primary Fragments. All weapons have some kind of cover or case if for no other reason than to make shipping and handling of the explosive charge safer and easier. A fragment from such a casing or cover is denoted a "primary fragment." The size and velocities of primary fragments are functions of the type of casing material and type and quantity of explosives encased. A detail description of the fragmentation of cased explosives is presented in section 2, paragraph 11 of this manual. Chapter 8 of NAVFAC P-397 deals with the response or behavior of concrete to primary fragment impact. This chapter is updated in the report by Healy, et al., titled Primary Fragment Characteristics and Impact Effects on Protective Barriers.

b. Secondary Fragments. In the event of an explosion, both primary and secondary fragments are ejected in all directions. Primary fragments have been defined in the preceding paragraph; hence, secondary fragments are usually objects in the path of the resulting blast wave that are accelerated to velocities which can cause impact damage. Secondary fragments can vary greatly in size, shape, initial velocity and range. A complete and detailed analysis of secondary fragments is presented in section 6.2.2. of DOE/TIC 11268, A Manual for the Prediction of Blast and Fragment Loadings on Structures.

7. STRUCTURAL ANALYSIS AND DESIGN. Design and analysis of a structure for blast loads is a dynamics problem. A structural-dynamic problem differs from its static-loading counterpart in two important respects. The first difference to be noted is the time-varying nature of the dynamic problem. Because the load and the response vary with time, it is evident that a dynamic problem does not have a single solution, as a static problem does. A succession of solutions corresponding to all times of interest in the response history can be established. However, a more fundamental distinction between static and dynamic problems is illustrated in Figure 1. If a single degree-of-freedom system (such as a mass, M , connected to a spring having a stiffness, K) is subjected to a static load, P , as shown in Figure 1a, the deflected shape depends directly on the applied load and can be calculated from P . On the other hand, if a load $P(t)$ is applied dynamically, as shown in Figure 1b, the resulting displacements of the system are associated with accelerations which produce inertia forces resisting the accelerations. In general, if the inertia forces represent a significant portion of the total load equilibrated by the internal elastic forces of a system, then the dynamic character of the problem must be accounted for in its solutions. However, if the applied load, $P(t)$, is applied very slowly such that the inertia forces are negligible ($x = 0$), then the applied load equals the resisting force in the spring and the load is considered a static load, although the load and time may be varying. Usually for blast design, the structure can be replaced

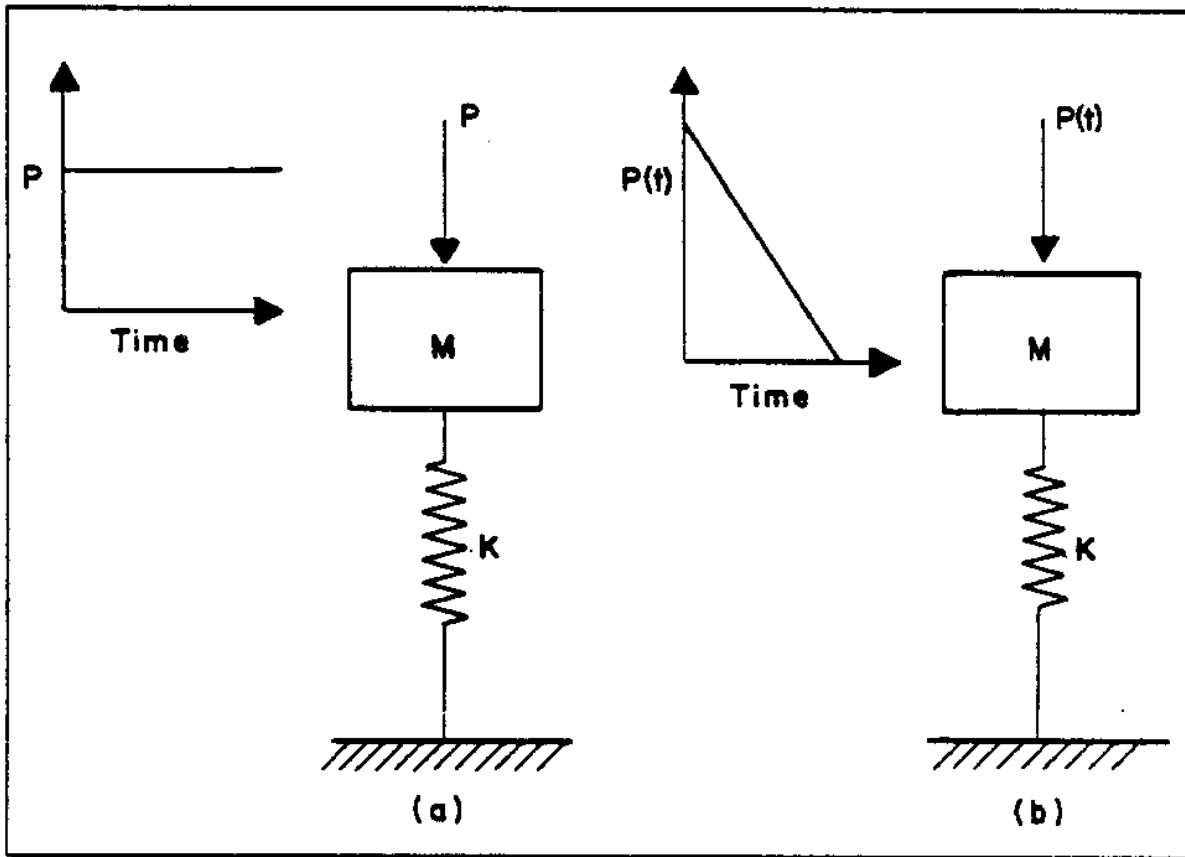

FIGURE 1
Basic Difference between Static and Dynamic Loads.

by a dynamically equivalent system, a single degree-of-freedom system for example, and the spring of the system is designed such that under the applied dynamic load, $P(t)$, the maximum deflection of the mass, X_{max} , is within acceptable limits.

The fundamental principles of dynamic analysis will not be discussed in this section because there are several books and manuals which deal with this subject, such as NAVFAC P-397, Introduction to Structural Dynamics by Biggs, and Dynamics of Structures by R.W. Clough, et al. The purpose of this section is to present guidance in the application of the principles used in the analyses of structures to resist the effects of blast (dynamic) loads.

a. Dynamically Equivalent System. Structural elements in general have a uniformly distributed mass and, as such, the elements can vibrate in a unlimited number of modes, shapes or frequencies. Usually, the fundamental mode shape or frequency is of greater significance to the designer since it dominates the response of the element. Neglecting contributions from higher modes introduces some errors, but these are insignificant.

(1) Single Degree-of-Freedom System. To derive a single degree-of-freedom system, the uniform mass of the system is considered lumped at point of maximum deflection and a deformation pattern (usually the fundamental mode) is assumed. A load-mass factor is introduced in order to simplify the design process and, by multiplying the actual mass of the element by the load-mass factor, the element is reduced to an equivalent single degree-of-freedom system which simulates the response (deflection, velocity, acceleration) of the actual element. Several references, including NAVFAC P-397, present single degree-of-freedom approximations for different structural configurations such as simply supported, fixed-fixed beams, one- and two-way slabs.

(2) Period of Vibration. The effective natural period of vibration for a single degree-of-freedom system is expressed as:

$$\text{EQUATION:} \quad T_{\text{N}} = 2[\pi] (K_{\text{LM}}m/K_{\text{E}})^{1/2} \quad (1)$$

where,

K_{LM} = load-mass factor

m = unit mass

K_{E} = equivalent unit stiffness of the system

(3) Effective Mass. As stated in paragraph 7.a.(1), a load-mass factor is applied to the actual mass of the element so as to reduce it to a equivalent single degree-of-freedom system. The product of the mass, m , and the load-mass factor, K_{LM} , is defined as the effective mass. Table 6-1 and Figure 6-5 of NAVFAC P-397 present load-mass factors for one- and two-way elements of various support conditions. The value of the load-mass factor, K_{LM} , as shown in Figure 2, depends in part on the range of behavior; i.e., elastic, elasto-plastic or plastic. Average values of K_{LM} are used for elasto-plastic, plastic, and post-ultimate ranges of behavior.

For:

$$X_{r_m\gamma} < X_{r_e\gamma}, \quad mK_{rLM\gamma} = K_{rLM\gamma}(\text{elastic})m = m_{r_e\gamma}$$

$$X_{r_e\gamma} < X_{r_m\gamma} < X_{r_p\gamma}, \quad mK_{rLM\gamma} = \frac{m[K_{rLM\gamma}(\text{elastic}) + K_{rLM\gamma}(\text{elasto-plastic})]}{2} = m_{r_a\gamma}$$

$$X_{r_p\gamma} < X_{r_m\gamma} < X_{r_l\gamma}, \quad mK_{rLM\gamma} = \frac{m[K_{rLM\gamma}(\text{elastic}) + K_{rLM\gamma}(\text{elasto-plastic})] + K_{rLM\gamma}(\text{plastic})}{2} = m_{r_u\gamma}$$

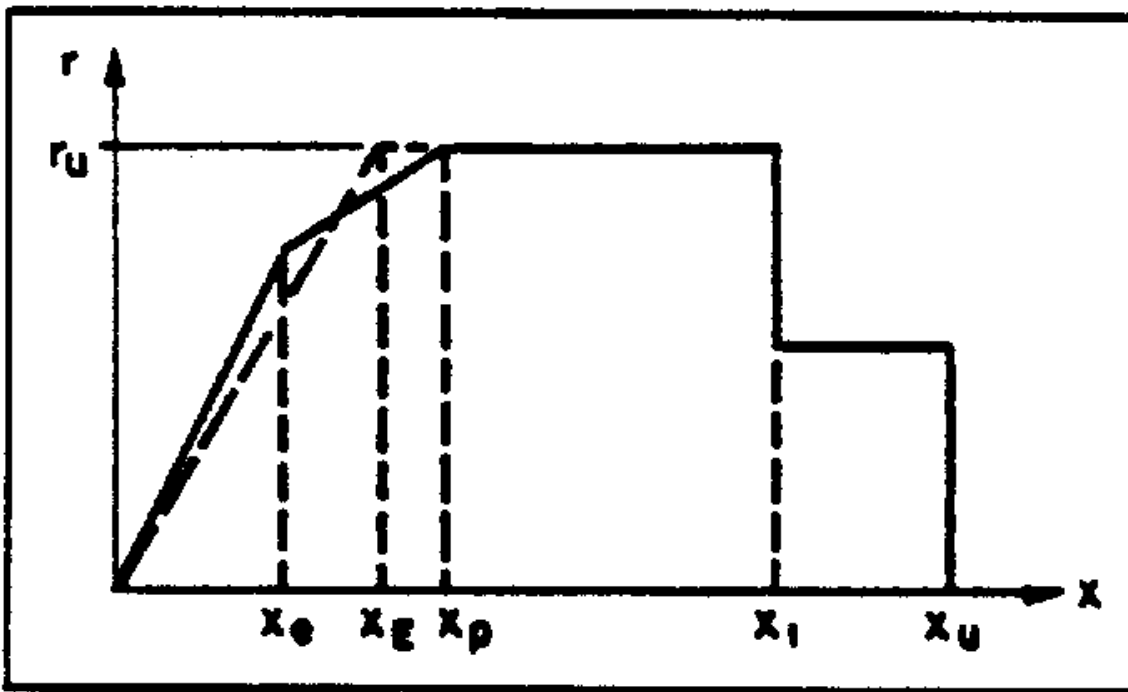

FIGURE 2
Resistance - Deflection Curve

b. Methods for Predicting Dynamic Response. In the report, Structures to Resist the Effects of Accidental Explosions - Class Notes by Keenan (hereafter referred to as Class Notes), several methods are presented for predicting the dynamic behavior of a single degree-of-freedom system subjected to a dynamic load; namely,

1. Phase Plane Method
2. Moment Area Method

(1) Phase Plane Solution. This is a graphical method of solution in which it is assumed that the structural system can be represented by a single degree-of-freedom system. It is very useful in predicting maximum deflections, velocities, and times to maxima for response in the elastic or elasto-plastic range. However, it can be very cumbersome for predicting response in the plastic range. For a complete description of this method, the designer is referred to the report by Keenan.

(2) Moment Area Method. This solution is easier to follow than the previous method; therefore, it will be described here in detail.

(a) The governing relationship for the motion of a simple spring-mass system is:

$$\text{EQUATION:} \quad p - r = ma \quad (2)$$

or:

$$\text{EQUATION:} \quad p/m - r/m = a \quad (3)$$

where,

p = applied pressure
 r = resistance of system
 m = mass of system
 a = acceleration of system.

Typical load and resistance diagrams are shown in Figure 3. A plot of p/m and r/m is shown in Figure 4.

(b) The net area under the curves between time $t = t'$ and t'' is equal to the change in velocity of the mass.

$$\text{EQUATION:} \quad \Delta v = \int_{t'}^{t''} (p/m - r/m) dt \quad (4)$$

Therefore, the net area under the curves between $t = 0$ and any t in Figure 4 is equal to the velocity, v , of the mass at t . The velocity is zero at the time of maximum displacement, $t_{r=m}$. Hence, the time to maximum displacement, $t_{r=m}$, is the time in Figure 4 when the net area under the curve is zero.

$$\text{EQUATION:} \quad A_{r1} = A_{r2} \text{ when } t = t_{r=m} \quad (5)$$

If an impulse, i , in combination with the load is applied to the system, then Equation (5) becomes:

$$\text{EQUATION:} \quad i_{r1}/m + A_{r1} = A_{r2} \text{ when } t = t_{r=m} \quad (6)$$

The change in displacement of the mass between any time $t = t'$ and $t = t''$ is:

$$\text{EQUATION:} \quad \Delta x = \int_{t'}^{t''} \int_{t'}^{t''} (p/m - r/m) dt dt \quad (7)$$

The net moment of the area under the curves between $t = 0$ and any time t in Figure 4 is equal to the displacement, x , of the mass at time t . Therefore, the maximum displacement of the mass is equal to the net moment of the areas under the curves about time, $t_{r=m}$:

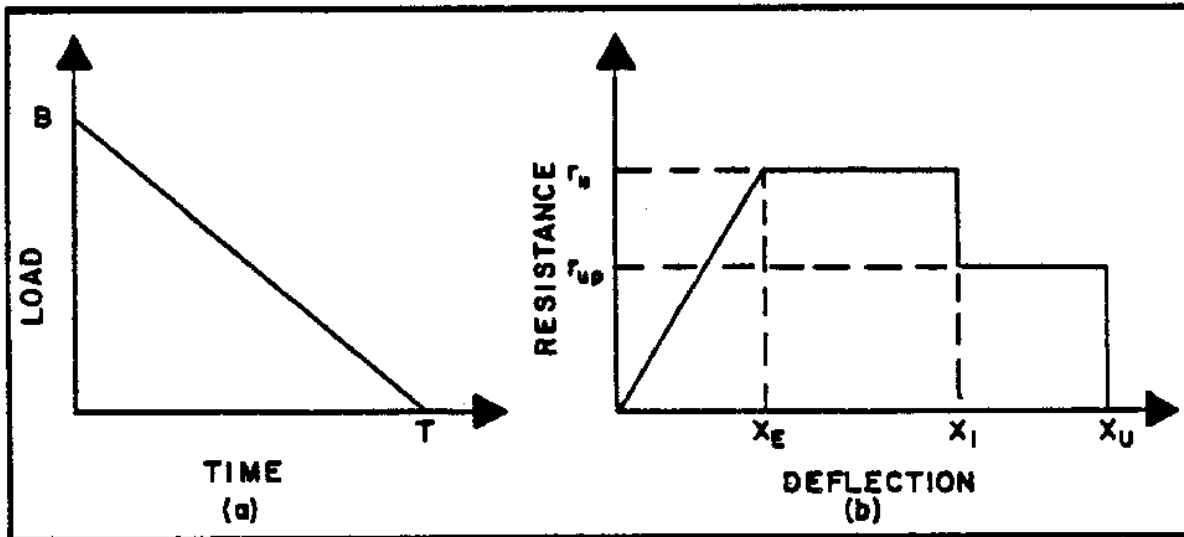

FIGURE 3
Load and Resistance Diagrams

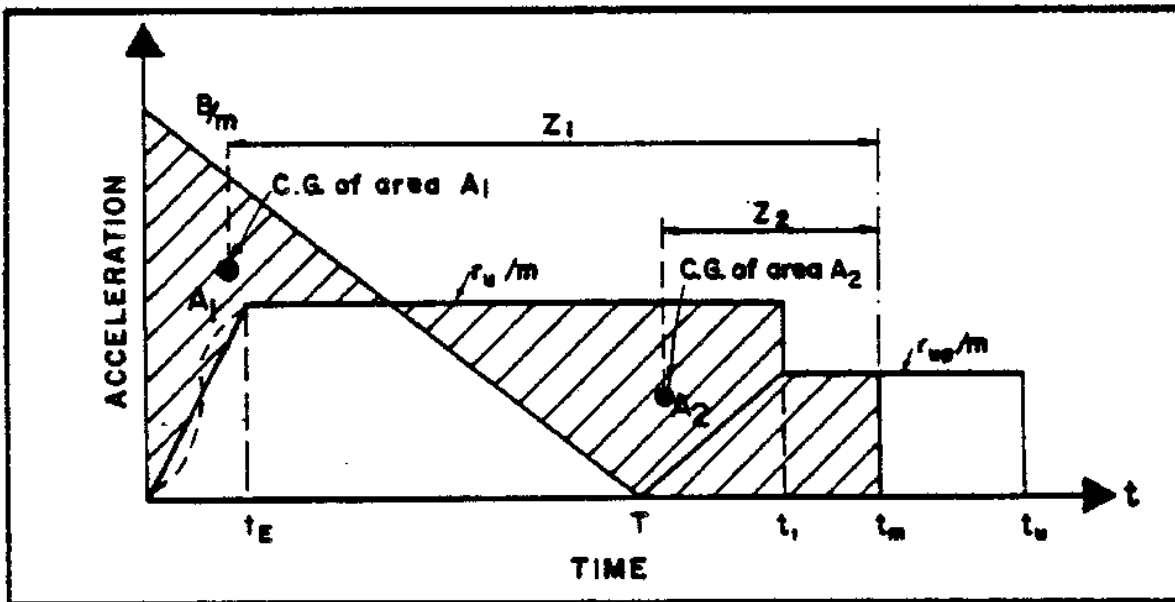

FIGURE 4
Acceleration Diagram

$$\text{EQUATION:} \quad X_{r1} = Z_{r1}A_{r1} - Z_{r2}A_{r2} \quad (8)$$

If an impulse, i_{r1} , is applied at time t_{r1} in addition to the load shown in Figure 3, then Equation (8) becomes:

$$\text{EQUATION:} \quad X_{r1} = (t_{r1} - t_{r1})(i_{r1}/m) + Z_{r1}A_{r1} - Z_{r2}A_{r2} \quad (9)$$

where Z_{r1} and Z_{r2} are the distances to the centroids of the areas A_{r1} and A_{r2} , respectively;

(c) The moment-area method assumes usually a linear variation in resistance with time. This approximation introduces very little error unless t_{r1} is equal to t_{rE} . For this approximation, the time t_{rE} can

be calculated from the following relationship. Let \bar{p} be the effective pressure during the time interval $0 < t < t_{rE}$, then

$$\text{EQUATION:} \quad X_{rE} = [(\bar{p}/m)t_{rE}]t_{rE}/2 \quad (10a)$$

multiplying by K_{rE} :

$$\text{EQUATION:} \quad X_{rE}K_{rE} = r_{r1} = \frac{2}{E}(pt_{rE}K_{rE})/2m \quad (10b)$$

but:

$$\text{EQUATION:} \quad K_{rE} = (4[\pi]L_{r1}^2)/T_{r1}L_{r1} \quad (10c)$$

therefore:

$$\text{EQUATION:} \quad r_{r1} = \frac{2}{E}pt_{rE}[\pi]L_{r1}^2/T_{r1}L_{r1} \quad (10d)$$

rearranging terms:

$$\text{EQUATION:} \quad t_{rE} = 0.226T_{r1}(r_{r1}/\bar{p})^{1/2} \quad (10e)$$

Let p_{rE} be the pressure at time $t = t_{rE}$. Then \bar{p} is expressed as:

$$\text{EQUATION:} \quad \bar{p} = (2B + p_{rE})/3 \quad (11)$$

where,

$$p_{rE} = B(1 - t_{rE}/T)$$

Equations (10e) and (11) are valid for $T \geq t_{rE_1}$

(d) In most cases, for $[\theta] \geq 5\text{deg.}$, the error is small if one neglects the effects of t_{rE_1} by assuming $t_{rE_1} = 0$.

(e) The method is especially useful for predicting maximum deflection and time to maximum when the response enters into the fully plastic range of the resistance diagram.

(f) The diagram in Figure 4 assumes a constant effective mass. In practical cases, this assumption is incorrect and both the load and resistance should be adjusted for the appropriate mass; i.e., at $t > t_{rE_1}$, use p/m_{r_1} and r_{r_1}/m_{r_1} and for $t > t_{r_1}$, use p/m_{rup_1} and r_{rup_1}/m_{rup_1} .

(g) An example problem and solution is presented at the end of this section to illustrate the moment-area method.

(3) Response Charts. The previously described methods of accurately determining the dynamic response of a single degree-of-freedom system can be very time-consuming. For certain simplified load and resistance functions, it is much quicker to predict maximum response from certain response charts. TN 5-858-3, Designing Facilities to Resist Nuclear Weapon Effects - Structures, contains several such charts which are extremely useful for design purposes. For a given load function, only the natural period of the system has to be known in order to determine the maximum DLF (Dynamic Load Factor) from the charts and, hence, the ratio of maximum dynamic-to-static stress. The maximum response of a pressure or pressure-time sensitive system with an elasto-plastic resistance function subjected to a triangular loading pulse is shown in Figure 6-7 of NAVFAC P-397.

8. PROTECTION CATEGORIES. The design and siting of protective structures shall conform to the criteria established in NAVFAC P-397, AMCR 385-100, DOD 6055.9-STD and 4145.26. For the purpose of analysis, the protection afforded by a facility can be subdivided into four categories:

a. Category 1. Protect personnel from fragments, falling portions of the structure and equipment. Protection should be provided for all personnel, including personnel performing the activities, personnel in other occupied areas and all transient personnel. Such protection can be achieved by controlling debris through suppression, containment, etc., or by establishing an exclusion area with positive access control.

b. Category 2. Protect equipment and supplies from fragment impact, blast pressures, structural motions and against the uncontrolled release of hazardous materials, including toxic chemicals, active radiological, or biological materials, etc. To control the release of toxic or radioactive materials, the enclosing structure and its associated ventilation, electrical, fire protection, and utility systems shall be designed so that personnel at a specified distance from the structure should not be exposed to more than a specified level of the toxic or radioactive material.

c. Category 3. Prevent communication of detonation by fragments and high-blast pressures.

d. Category 4. Prevent mass detonation of explosives as a result of subsequent detonation produced by communication of detonation between adjoining areas. As in the case of Category 3, minimum separation distances between structures in Category 4 can be reduced when they are designed to totally contain the effects of an accident (blast pressures and fragments).

9. EXAMPLE PROBLEM - Moment Area Method

Problem: Find the time to maximum displacement for the load and resistance shown below if $X_{rE} < X_{rm} < X_{rl}$, and the duration of the blast load is less than t_{rE} .

Given:

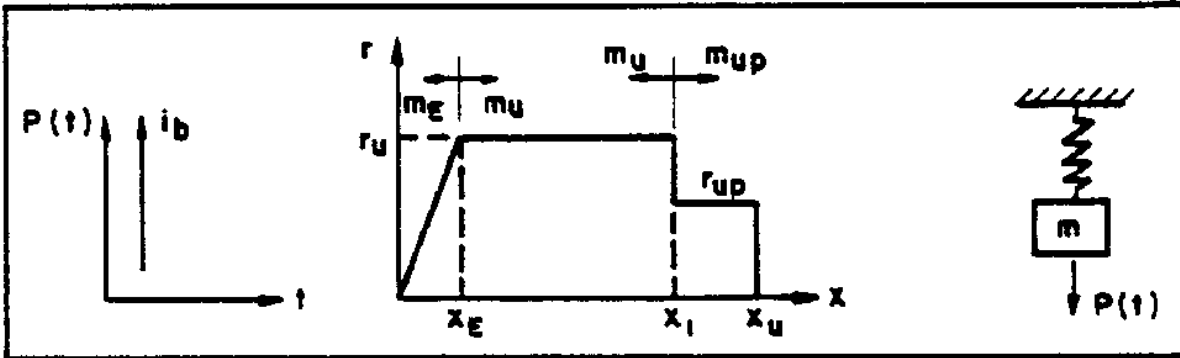

FIGURE 5
Resistance Function

Solution:

- (1) Construct a plot of p/m and r/m .
- (2) Calculate the displacement, X_{rE} of mass at time t_{rE} .
- (3) Express t_{rE} in terms of X_{rE} .
- (4) Determine the net area up to the time $t = t_{rm}$. This time is when the new area under curve is zero.
- (5) Calculate t_{rm} .

Calculation:

Given: The load and resistance diagrams shown in Figure 5.

Solution:

(1) Construct a plot of p/m and r/m .

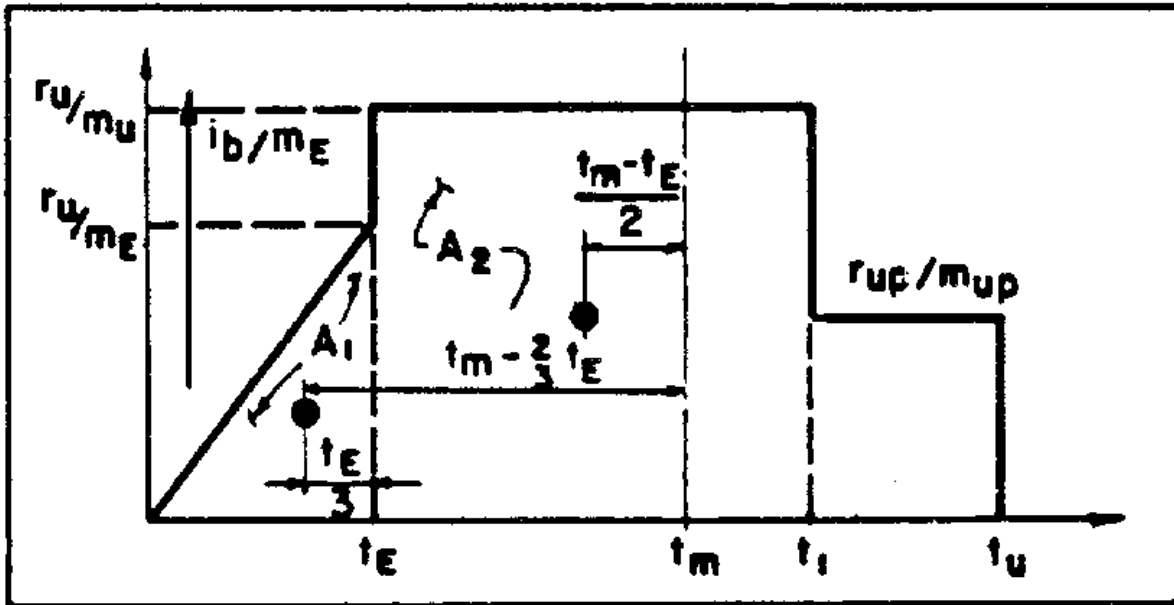

FIGURE 6

Load and Resistance Functions

(2) The net moment of areas about $t_{rE} = X_{rE}$

$$X_{rE} = i_{rb} t_{rE} / m_{rE} - (r_{ru} t_{rE} / 2m_{rE}) t_{rE} / 3$$

therefore:

$$(3) t_{L2}^2 / r_{ru} - (6i_{rb} / r_{ru}) t_{rE} + 6m_{rE} X_{rE} / r_{ru} = 0$$

$$t_{rE} = (6i_{rb} / 2r_{ru}) - (1/2) [(6i_{rb} / r_{ru})^2 t_{L2}^2 - 4(6m_{rE} X_{rE}) / r_{ru}]^{1/2}$$

$$= (3i_{rb} / r_{ru}) - (1/r_{ru}) [9i_{rb}^2 t_{L2}^2 - 6m_{rE} r_{ru} X_{rE}]^{1/2}$$

(4) At maximum deflection, the velocity is zero. Therefore, the net area up to $t = t_{rm}$ must equal zero.

$$(i_{rb} / m_{rE}) - r_{ru} t_{rE} / 2m_{rE} - (r_{ru} / m_{ru}) (t_{rm} - t_{rE}) = 0, \text{ the velocity at } t = t_{rm}$$

therefore:

$$(5) t_{rm} = m_{ru} / r_{ru} [r_{ru} (1/m_{ru} - 1/2m_{rE}) t_{rE} + i_{rb} / m_{rE}]$$

Substituting for t_{rE} :

$$t_{rm} = [3i_{rb} / r_{ru} - (1/r_{ru}) (9i_{rb}^2 t_{L2}^2 - 6m_{rE} r_{ru} X_{rE})^{1/2}] (1 - m_{ru} / 2m_{rE})$$

or:

$$t_{rm} = (i_{rb}/r_{ru})(3 - m_{ru}/2m_{re}) + (1/r_{ru})[(m_{ru}/2m_{re}) - 1] \\ \times (9i_{L}^2 - 6m_{re}r_{ru}X_{re})^{1/2}$$

10. NOTATION.

a	-	Acceleration of system, in/ms ²
B	-	Pressure intensity, psi
i_{rb}	-	Unit blast impulse, psi-ms
K_{re}	-	Equivalent elastic unit stiffness
K_{LM}	-	Load-Mass factor
m	-	Unit mass, psi-ms ² /in
m_{ra}	-	Average of the effective elastic and plastic unit masses, psi-ms ² /in
m_{re}	-	Effective elastic unit mass, psi-ms ² /in
m_{ru}	-	Effective unit mass in the ultimate range, psi-ms ² /in
m_{rup}	-	Effective unit mass in the post-ultimate range, psi-ms ² /in
\bar{p}	-	Applied pressure, psi
\bar{p}	-	Effective pressure during time interval $0 < t < t_{re}$, psi
P_{re}	-	Pressure at time $t = t_{re}$, psi
r	-	Unit resistance of system, psi
r_{ru}	-	Ultimate unit resistance, psi
r_{rup}	-	Post-ultimate unit resistance, psi
t_{re}	-	Time to reach maximum elastic deflection, ms
t_{rm}	-	Time at which maximum deflection occurs, ms
t_{ru}	-	Time at which ultimate failure occurs, ms
t_{rl}	-	Time at which partial failure occurs, ms
T	-	Load duration, ms
T_N	-	Natural period of vibration, ms
v	-	Velocity, in/ms

- $X_{\Gamma e}$ - Elastic deflection, in
- $X_{\Gamma E}$ - Equivalent elastic deflection, in
- $X_{\Gamma m}$ - Maximum deflection, in
- $X_{\Gamma p}$ - Plastic limit deflection, in
- $X_{\Gamma u}$ - Ultimate failure deflection, in
- $X_{\Gamma l}$ - Partial failure deflection, in
- [theta] - Support rotation, degrees

SECTION 2. EFFECTS OF EXPLOSIONS

1. SCOPE AND RELATED CRITERIA. The topics covered in this section include:

a. Scope.

1. Safety Factor Introduced to Weight of Explosives.
2. Blast Pressure Output.
3. Unconfined Explosions.
4. Partially Vented Explosions.
5. Fully Vented Explosions.
6. Airblast From Underwater Explosions
7. External Blast Loads on Structures.
8. Pressure Increase Within Structure.
9. Multiple Explosions.
10. Primary Fragments.

The topics listed above are dealt with in brief in this section. More detailed information is provided in the texts and documents referenced in this manual. Design examples are provided in paragraph 12 to help the user understand the procedures outlined in this section.

b. Related Criteria. In blast resistant design, the principal effects of the explosive output to be considered are blast pressures and primary fragments. Usually, the blast pressures are the governing factor in the determination of the structure's response.

2. SAFETY FACTOR AND ACCURACY.

a. Simplifications in the Development of Design Procedures. Certain simplifications have been made in the development of the design procedures presented in this manual. As a result, an analysis of a structure using these procedures will generally result in a conservative estimate of the structure's capacity and, consequently, structures designed using these procedures will generally be adequate for the blast load exceeding the assumed loading conditions.

b. Modification of Charge Weight. Certain unknown factors can result in an overestimate of the protective structure's capability to resist the effects of an explosion. These factors, reflections of the shock waves, structural response, construction methods, quality of construction materials, workmanship, etc., vary for each facility design. To compensate for weaknesses resulting from these factors, it is recommended that the "effective charge weight" or the actual charge weight, depending upon the method used to determine the TNT equivalent, be increased by 20 percent for design purposes. Modification of

this increased "effective charge weight" in a particular design situation may only be made for those cases which are sufficiently simple and well tried to justify this action. Such modifications must be approved by the cognizant military construction agency.

3. BLAST PRESSURE OUTPUT.

a. Blast Phenomena. The blast effects of an explosion are in the form of a shock wave composed of a high-pressure shock front which expands outward from the center of the detonation, with intensity of the pressure decaying with distance and as a function of time. The magnitude and other characteristics of the blast loads associated with the explosion are a function of the following:

1. Explosive properties.
2. Location of the explosive relative to the structure.
3. Amplification of the pressure by its interaction with the ground, barrier, etc.

Besides NAVFAC P-397, there are several good texts which deal with the basic physics of air blast and the prediction of blast wave properties for (HE) explosives. One of these is Explosions in Air by Baker.

b. TNT Equivalents. The major quantity of blast effects data presented in NAVFAC P-397 and other similar manuals pertains to the blast pressure output of TNT explosions.. These data can be extended to include other potentially mass-detonating materials whose shapes differ from those considered in these manuals, by relating the explosive energy of the effective charge weight of these materials to that of an equivalent weight of TNT. For blast-resistant design in general, the TNT equivalent should be based upon a pressure and impulse relationship depending upon the anticipated pressure-design range. Comparison of the heats of detonation of other explosives can help in determining their TNT equivalences. TNT equivalences for different explosives are presented in Table 1.

c. Cased Explosives. Some of the energy released when a cased charge detonates is lost through strain energy to break up the casing and through kinetic energy to accelerate the fragments of the casing. No longer are the blast parameters simply a function of scaled standoff distance ($R/W^{1/3}$), but they become a function of other variables such as casing weight, W_{rc} , charge weight, W , etc. As stated in Class Notes by Keenan, effective charge weight, W_{eff} , for computing blast pressures from a cased charge is less than the total charge weight, W , and the difference increases with the ratio of metal case weight to the charge weight, W_{rc}/W . W_{eff} is given by Equation (12a).

$$\text{EQUATION:} \quad W_{eff} = F \times W \quad (12a)$$

where F is given by:

$$\text{EQUATION:} \quad F = 0.6 + 0.4 / (1 + 2W_{rc}/W) \quad (12b)$$

TABLE 1
TNT Pressure Equivalences

Explosive Material	TNT Equivalent Weight[1]
Baratol	0.525
Boraticol	0.283
BTF	1.198
Composition B	1.092
Composition C-4	1.129
Cyclotol 75/25	1.115
DATB/DATNB	0.893
DIPAM	0.959
DNPA	0.752
EDNP	0.874
FEFO	1.149
HMX	1.042
HNAB	1.044
HHS	1.009
LX-01	1.222
LX-02-1	1.009
LX-04	1.007
LX-07	1.058
LX-08	1.406
LX-09-1	1.136
LX-10-0	1.101
LX-11-0	0.874
LX-14	1.119
NG	1.136
NQ	0.75
OCTOL 70/30	1.113
PBX-9007	1.108
PBX-9010	1.044
PBX-9011	1.087
PBX-9205	1.037
PBX-9404	1.108
PBX-9407	1.136
PBX-9501	1.129
Pentolite 50/50	1.085
PETN	1.169
RDX	1.149
TETRYL	1.071
TNT	1.0

[1]Values are based on calculated heats of detonation.

where,

W_{rc} = weight of casing
 W = charge weight

Various formats for determination of F have been suggested by different investigators (see Some Effects of Light Surrounds and Casings on the Blast from Explosives by Dewey) with Equation (12c) giving the best fit for steel-cased explosives.

EQUATION:
$$F = 0.2 + 0.8 / (1 + W_{rc} / W) \quad (12c)$$

Equation (12c) should be used for other materials besides steel.

4. UNCONFINED EXPLOSIONS.

a. Free-Air Burst. Free-air burst blast pressures are the blast loadings acting on a structure due to an explosion in which no amplification of the initial shock waves occurred.

(1) When the shock wave impinges on a surface oriented so that a line which describes the path of travel of the wave is normal to the surface, then the point of initial contact is said to sustain the maximum (normal reflected) pressure and impulse. The peak pressures, impulses, velocities, and other parameters of this shock wave for a bare spherical TNT explosive charge are given in Figure 4-5 of NAVFAC P-397 vs. the scale distance, $Z = R_{rc} / W^{1/3}$.

(2) The effect of the angle of incidence on the peak reflected pressures is shown in Figure 4-6 of NAVFAC P-397. For design purposes, the other blast parameters, except the duration of the wave, may be taken as those corresponding to the reflected pressure P_{rc} and are obtained from Figure 4-5. The duration of the blast wave corresponds to the duration of the free air pressure.

b. Surface Burst. An explosion occurring on or very near the ground surface is considered to be a surface burst. Unlike a free-air burst, the initial wave of the explosion is reflected and reinforced by the ground surface to produce a reflected wave. There exists a theoretical procedure used to estimate the magnitude of the incident pressure (NAVFAC P-397); however, the impulse calculated from this method is generally conservative relative to test results which were used to construct Figure 4-12 (NAVFAC P-397). A quick glance at both Figures 4-5 and 4-12 will show that for a given distance from a detonation of the same weight of explosive, all of the parameters of the surface burst environment are larger than those for the free-air environment.

c. Pressure-Time Variation. In the analysis of certain structures (steel frames, cold-formed members), a more accurate definition of the variation of the pressure as a function of time is required. This variation is usually referred to as the "p-T curve" of the blast wave. As stated in Appendix A of Blast Capacity Evaluation of Pre-Engineered Buildings by Stea, et al., this variation can be approximated by the following functions:

(1) Positive Phase p-T Curves. For the positive phase of a blast wave, it is suggested that a close approximation of the p-T curve can be obtained by using the following relationship:

$$\text{EQUATION:} \quad P_{\Gamma S\gamma} = P_{\Gamma SO\gamma} (1 - t_{\Gamma S\gamma}/t_{\Gamma O\gamma}) e^{-[\alpha] (t_{\Gamma S\gamma}/t_{\Gamma O\gamma})^{\downarrow}} \quad (13a)$$

where,

$P_{\Gamma S\gamma}$ = pressure at time $t_{\Gamma S\gamma}$
 $P_{\Gamma SO\gamma}$ = peak incident pressure
 $t_{\Gamma S\gamma}$ = positive phase time of interest
 $t_{\Gamma O\gamma}$ = positive phase duration
 $[\alpha]$ = constant that determines the form of the p-T curve

The values of $[\alpha]$ can be expressed as a function of constant, k , which, in turn, is defined as:

$$\text{EQUATION:} \quad k = i_{\Gamma S\gamma} / P_{\Gamma SO\gamma} t_{\Gamma O\gamma} \quad (13b)$$

where $i_{\Gamma S\gamma}$, $P_{\Gamma SO\gamma}$, and $t_{\Gamma O\gamma}$ are obtained from Figure 4-5 of NAVFAC P-397. The numerical relationship between k and $[\alpha]$ is listed below:

k	0.70	0.60	0.50	0.40	0.30	0.20	0.10
$[\alpha]$	- 0.93	- 0.52	0	0.71	1.77	3.67	8.87

To simplify the solution, normalized plots of the positive phase p-T curve as a function of k values are presented in Figure 7a. For pressures up to 10 psi, these curves are applicable to both incident and reflected pressures.

(2) Negative Phase p-T Curves. The negative pressure curve can be approximated by a cubical parabola expressed as:

$$\text{EQUATION:} \quad \bar{P}_{\Gamma S\gamma} = \bar{P}_{\Gamma SO\gamma} (6.75 \bar{t}_{\Gamma S\gamma} / \bar{t}_{\Gamma O\gamma}) (1 - \bar{t}_{\Gamma S\gamma} / \bar{t}_{\Gamma O\gamma})^{\downarrow 2} \quad (14a)$$

where,

$\bar{P}_{\Gamma S\gamma}$ = negative pressure at time $\bar{t}_{\Gamma S\gamma}$
 $\bar{P}_{\Gamma SO\gamma}$ = peak incident negative pressure
 $\bar{t}_{\Gamma S\gamma}$ = negative phase time of interest
 $\bar{t}_{\Gamma O\gamma}$ = negative phase duration

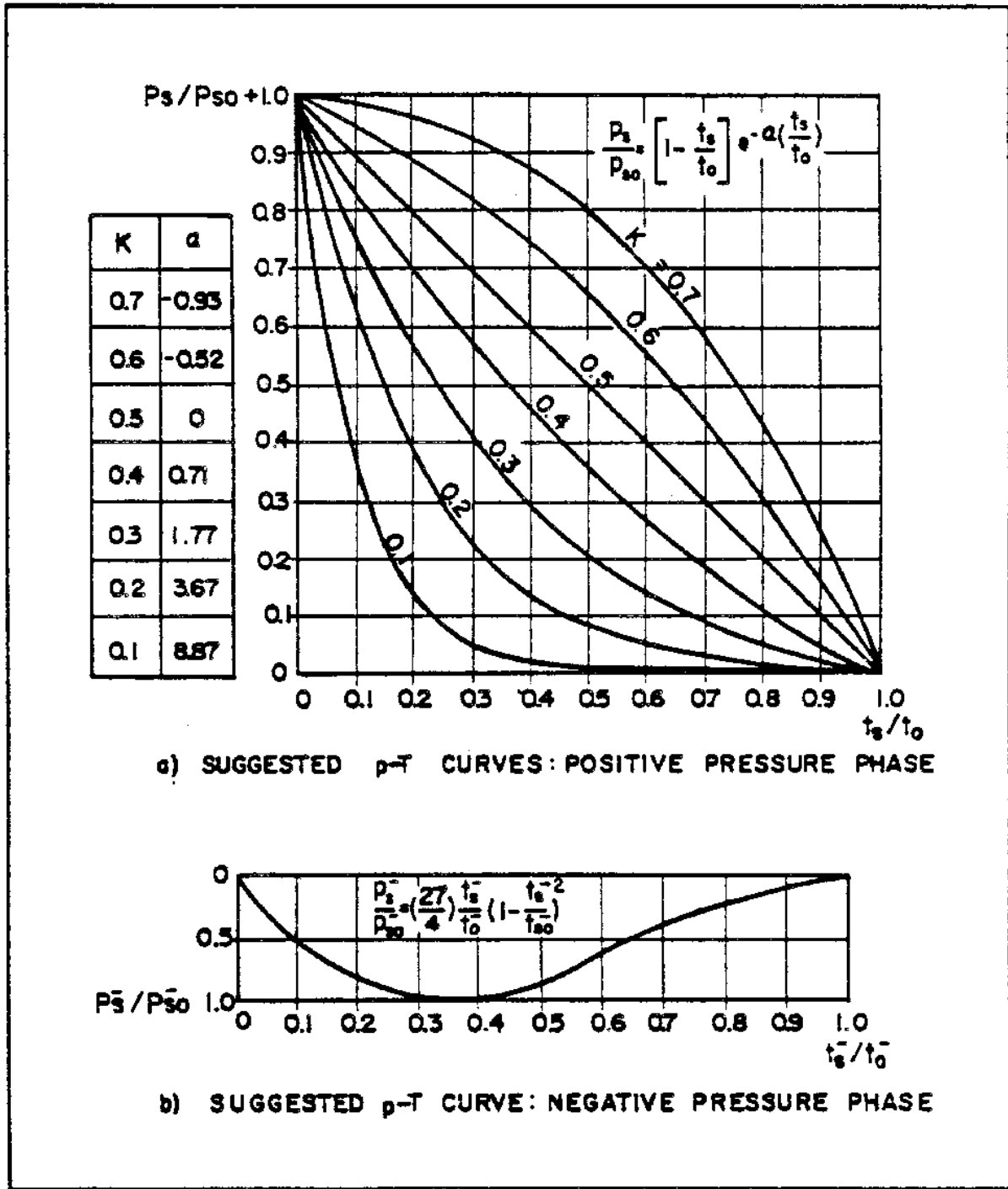

FIGURE 7
Suggested Pressure versus Time (p-T) Curves

(a) However, this curve gives a single definite value of $k^- = 0.5625$. According to the report, Loading Characteristics of Air Blasts from Detonating Charges by Granstrom, this value is assumed to be valid for scaled distances greater than $15.2 \text{ ft/lb}^{1/3}$. A plot of Equation (14a) is given in Figure 7b. For values of k^- not equal to 0.5625, the suggested curve should be adjusted such that the area under it equals the negative phase impulse. The value of k^- is defined as follows:

$$\text{EQUATION: } k^- = i_{-r} s_{\gamma} / P_{-r} s_{\gamma} t_{-r} \quad (14b)$$

(b) Figure 7b is applicable to both incident and reflected pressures for incident pressure of approximately 10 psi or less.

5. PARTIALLY VENTED EXPLOSIONS.

a. Definition. Gas pressure pulses developed from partially vented explosions in cubicles can be far more damaging than the shock pulse, depending on the duration of the gas pulse, t_{rg} , relative to the duration of the shock pulse, t_{ro} . If $t_{rg}/t_{ro} < 1$, the explosion is classified as a fully vented explosion and the gas pulse, if any, can be neglected in the design of the cubicle. For $t_{rg}/t_{ro} > 1$, the explosion is classified as a partially vented explosion and both the gas and shock pulses must be considered in the design of the cubicle.

b. Interior Blast Loading. Information pertaining to the blast environment from partially confined explosions is not available in NAVFAC P-397. Results of the study done by Keenan and Tancreto, Blast Environment from Fully and Partially Vented Explosions in Cubicles, are presented in the following paragraphs:

(1) Peak Gas Pressure. When the openings in a cubicle-type structure are small compared to the total surface area, the gas pressure duration (resulting from an internal explosion) is often large relative to the fundamental period (T_{rn}) of the walls and roof of the cubicle.

(a) The maximum mean pressure p_{rmo} is recommended in NAVFAC P-397 to be used as the basis for design and Figure 4-65 of referenced manual illustrates the relationship between p_{rmo} and the charge-to-volume ratio.

(b) Figures 8 and 9 show the variation of the peak gas pressure with charge-to-volume ratio for a partially vented explosion in a 4-wall cubicle. Both figures (for TNT and Composition B) were constructed based upon experiments performed for relatively small vent areas with the charges located at the geometric centers of the cubicles.

(2) Duration of Gas and Shock Pressures. The relationship between the duration of the positive pressure in a cubicle and vent area can be expressed as:

$$\text{EQUATION: } t_{rg} / W^{1/3} = 2.26 (AW^{1/3} / V)^{-0.86} \text{ for } A/V^{2/3} < 0.21 \quad (15)$$

$$\text{EQUATION: } t_{ro} / W^{1/3} = 0.664 (AW^{1/3} / V)^{-1.14} \text{ for } A/V^{2/3} > 0.60 \quad (16)$$

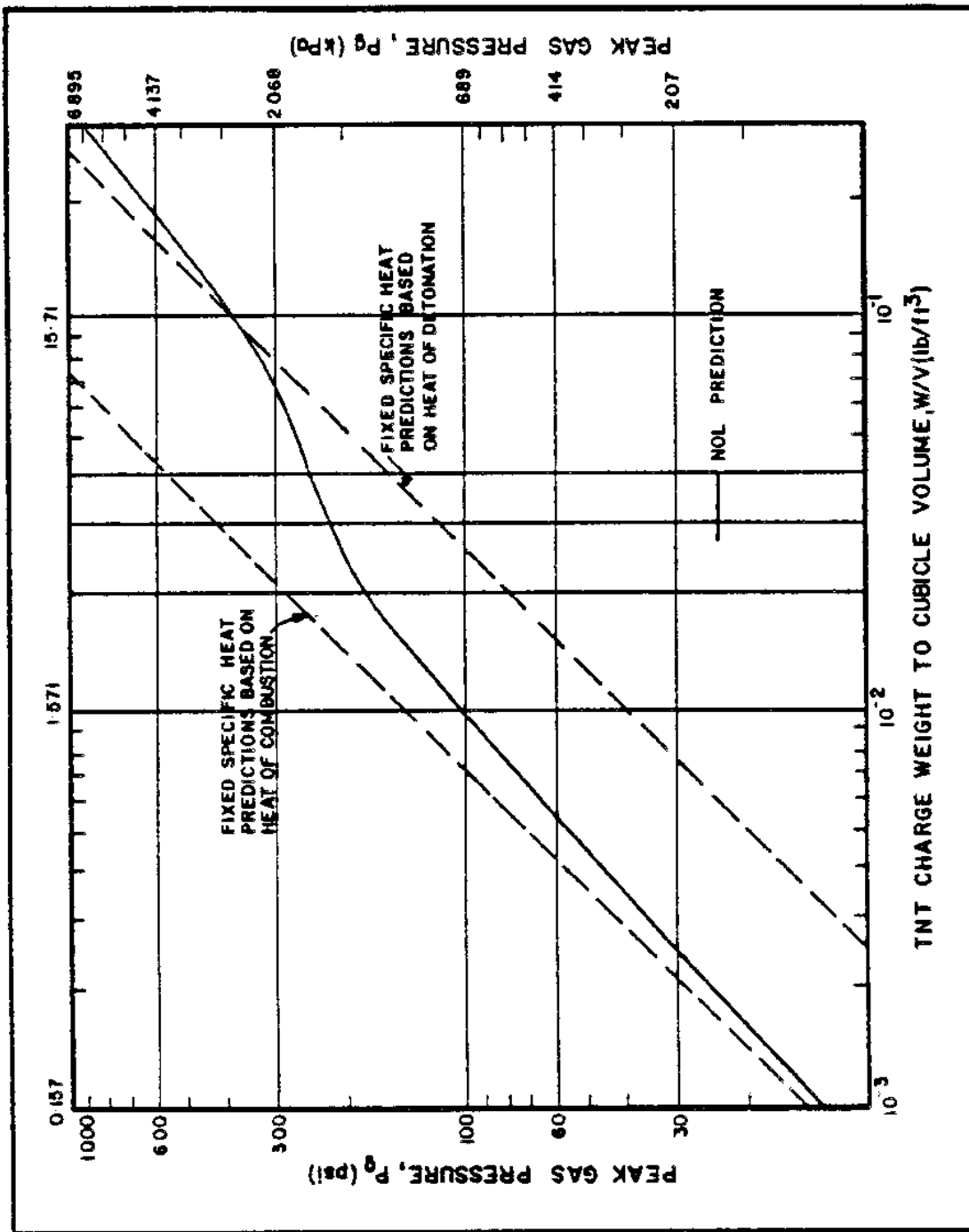

FIGURE 8

Peak Gas Pressure from a Partially Vented Explosion of TNT in a 4 - Wall Cubicle

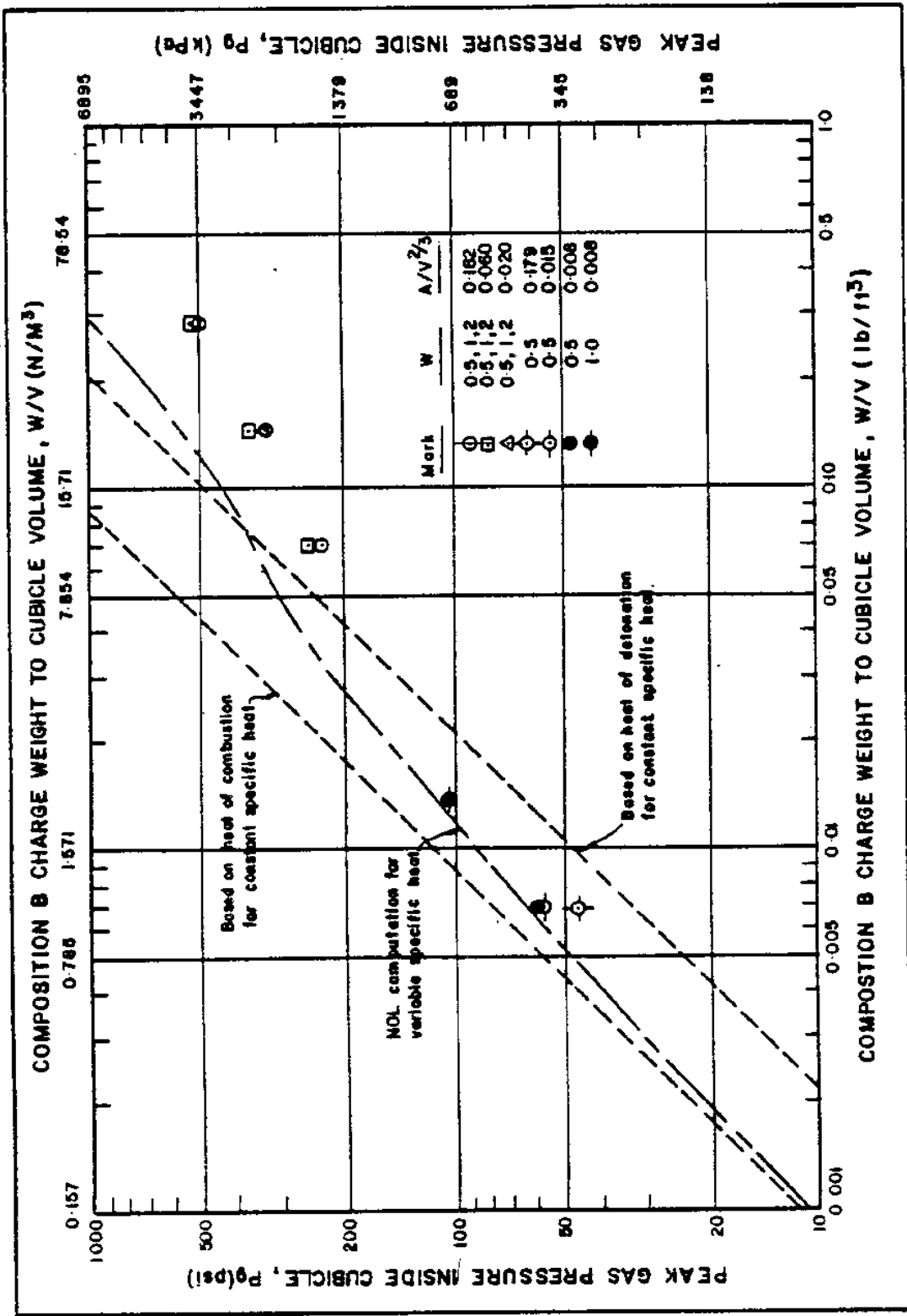

FIGURE 9
 Peak Gas Pressure from a Partially Vented Explosion
 of Composition B in a 4 - Wall Cubicle

where,

t_{pg} = duration of gas pressure
 t_{po} = duration of shock pressure
 A = vent area, ft²
 W = charge weight, lb
 V = volume of cubicle, ft³

It should be emphasized that Equations (15) and (16) are only approximate and were based on charges located at the geometric center of the cubicles. When the other charge locations are involved, Equation (17) should be used. This equation was recommended in NAVFAC P-397 to be used when the duration of the shock pressure on the wall of a cubicle is to be calculated.

$$\text{EQUATION: } t'_{po} = (t_{A})_{F} - (t_{A})_{N} + (t_{po})_{F} \quad (17)$$

where,

t'_{po} = design duration of the positive pressure, ms
 $(t_{A})_{F}$ = time of arrival of the blast wave at the point on the wall farthest from the charge, R_{F}
 $(t_{A})_{N}$ = time of arrival of the blast wave at the point on the wall nearest to the charge, R_{N}
 $(t_{po})_{F}$ = duration of the blast pressure at the point on the wall farthest from the charge, R_{F}

The procedure for solving Equation (17) is dealt with in depth in NAVFAC P-397.

(3) Impulse of Gas Pressure. Keenan and Tancreto performed experiments to determine the relationship between the scaled peak impulse of the gas pressure inside a cubicle and the scaled vent area of the cubicle. Figure 10 illustrates this relationship which can also be described by:

$$\text{EQUATION: } i_{pg}/W^{1/3} = 569(A/W^{2/3})^{-0.78}(W/V)^{-0.38} \quad (18)$$

for $A/V^{2/3} < 0.21$.

Again, the curves in Figure 10 and Equation (10) were derived for a charge located at the geometric center of the cube. NAVFAC P-397 contains a series of charts (Figures 4-17 through 4-62) for predicting the average shock impulse acting on the walls of a cubicle of any shape and size.

c. Blast Environment Outside Cubicle. The entire process of detonation in a cubicle and gas venting produces a train of shock waves which travel away from the cubicle and attenuate with distance. At any point outside the cubicle, the pressure-time history has the characteristics of an unconfined explosion, except that it contains a number of pronounced pressure spikes, particularly close to the cubicle. The first pressure spike constitutes the largest pressure; the number of spikes decreases with distance and, for a given charge weight, the number of spikes tends to decrease with increasing vent area.

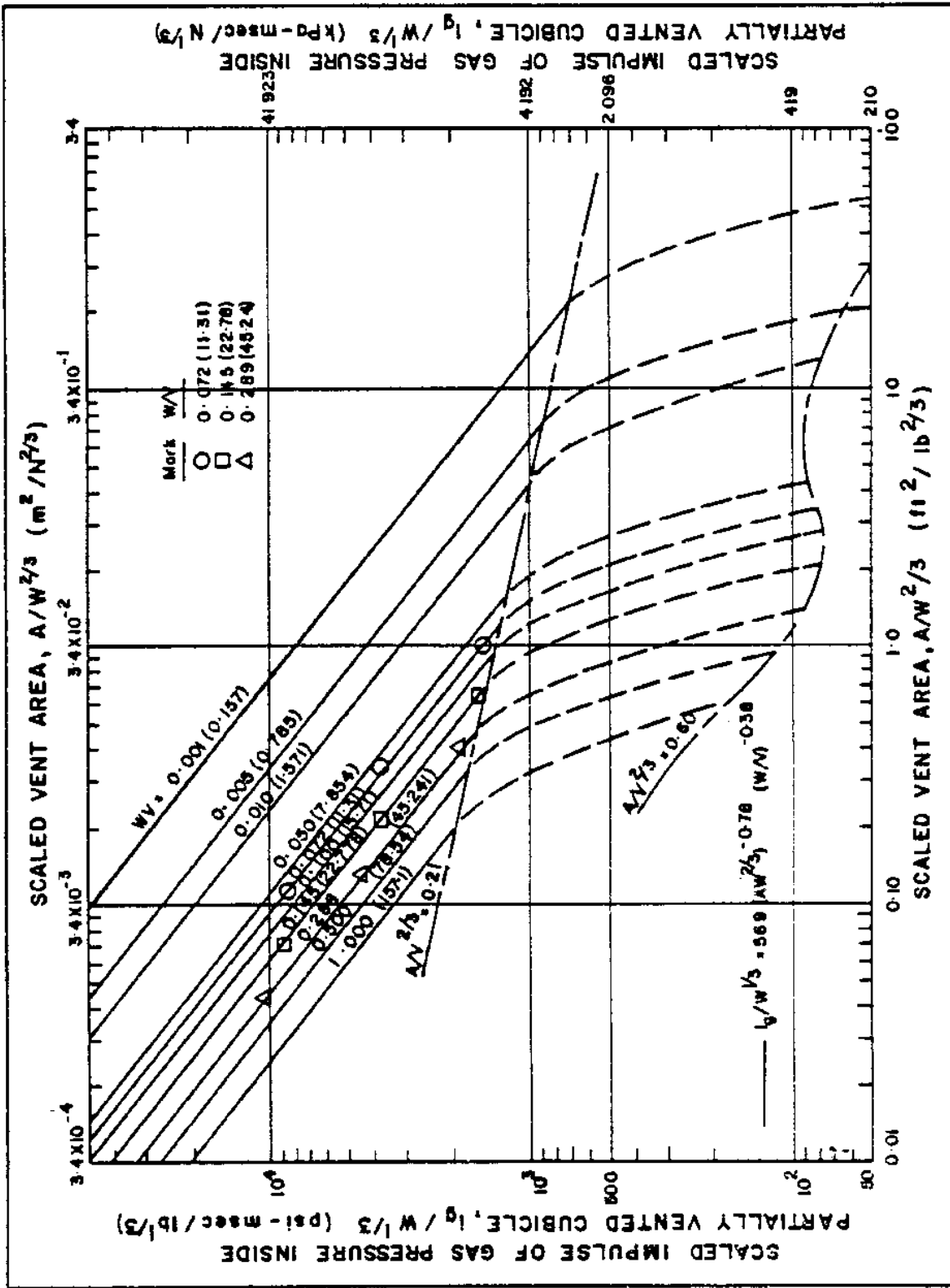

FIGURE 10 Scaled Impulse of Gas Pressure Inside a Partially Vented Cubicle

(1) Peak Positive Pressure. The peak positive pressure, $P_{\Gamma SO_1}$, outside a partially vented cubicle can be expressed as

$$\text{EQUATION: } P_{\Gamma SO_1} = 290 (A/V)^{2/3} (R/W)^{1/3} (1.401)^{-1.496} \quad (19)$$

Equation (19) was derived from experimental data involving a cube-shaped cubicle and the following conditions:

$$0.063 < W/V < 0.375 \text{ lb/ft}^3$$

$$0.0198 < A/V^{2/3} < 1.000$$

$$1.59 < R/W^{1/3} < 63.0 \text{ ft/lb}^3$$

(a) As indicated by Keenan and Tancreto, exercise caution in applying Equation (19) to other conditions. This equation was used to construct Figure 11, based on Composition B explosive, cylindrical charges, and cube-shaped cubicles with the charge at the geometric center of the cubicle. However, changes in these parameters would introduce only small errors.

(b) Equation (19) and Figure 11 were constructed for the pressures outside a 4-wall cubicle on a horizontal plane located at the elevation of the vent area. When the location of interest lies at a different location other than that of the vent area, the procedure outlined in Appendix C of Blast Environment from Fully and Partially Vented Explosions in Cubicles by Keenan and Tancreto should be followed.

(2) Peak Positive Impulse. Figure 12 taken from Blast Environment from Fully and Partially Vented Explosions in Cubicles is useful for selecting the vent area needed to limit the peak positive impulse at any range outside a 4-wall cubicle. The chart probably yields reasonable values of $i_{\Gamma S_1}/W^{1/3}$ (scaled impulse) within the range of the test data; that is, $0.072 < W/V < 0.289$ and $0.008 < AW^{1/3}/V < 0.721$. Except at very close-in ranges ($R/W^{1/3} < 10$), the peak positive impulse outside a 4-wall cubicle without a roof is about the same as that from an unconfined surface burst.

(3) Duration of Positive Pressure. For design purposes, the actual pressure pulse is approximated by a equivalent triangular pressure-time pulse with the duration expressed as

$$\text{EQUATION: } t'_{\Gamma O_1}/W^{1/3} = 2(i_{\Gamma S_1}/W^{1/3})/P_{\Gamma SO_1} \quad (20)$$

The scaled duration of the impulse, $t_{\Gamma O_1}/W^{1/3}$, is underestimated by the equation above for small degrees of venting and scaled distances. In such cases, engineering judgment should be exercised.

6. FULLY VENTED EXPLOSIONS.

a. Definition. According to Keenan and Tancreto, a fully vented explosion is one that occurs in a environment where $A/V^{2/3} \geq 0.6$.

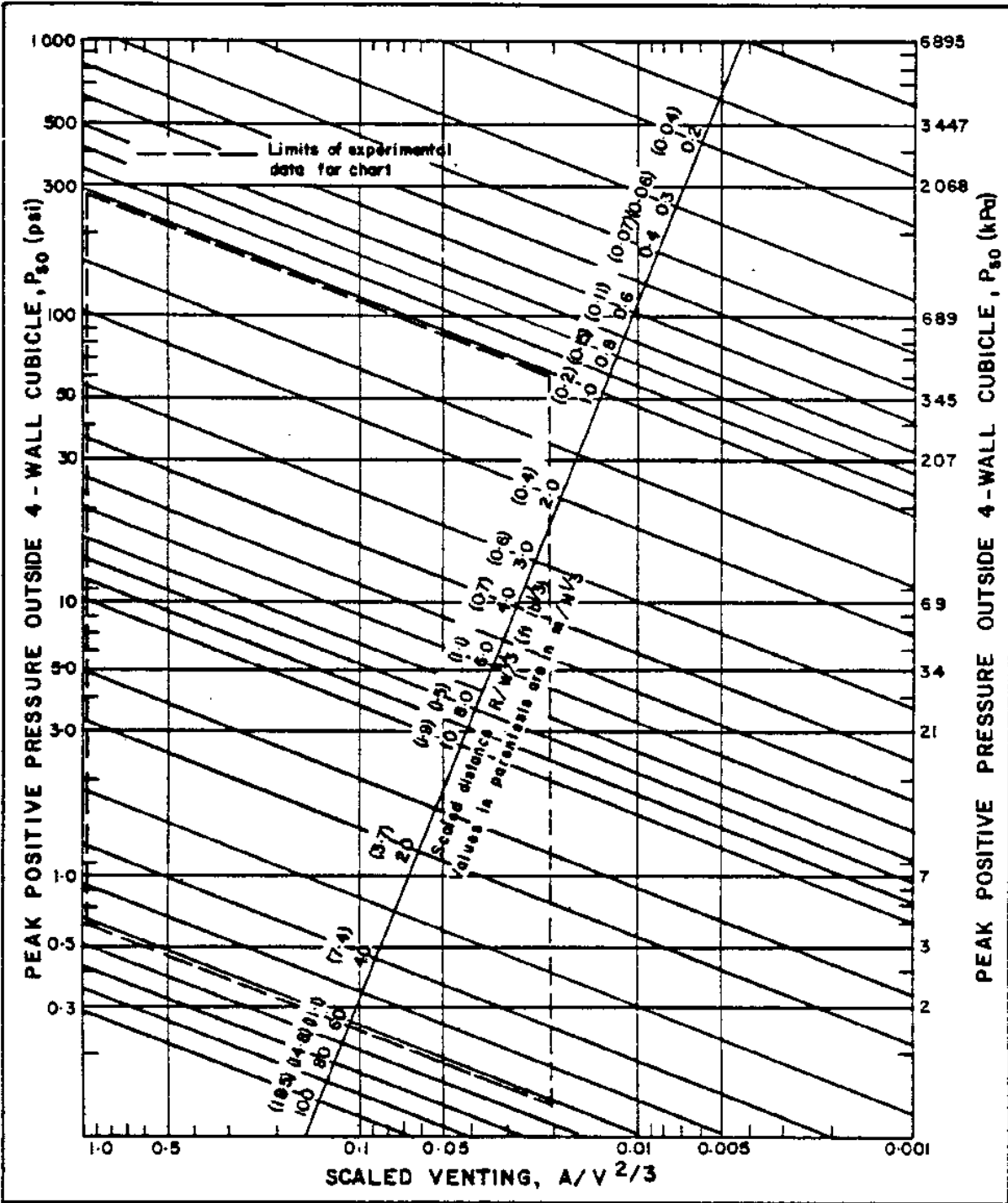

FIGURE II
 Design Chart for Vent Area Required to Limit Pressures at any Range Outside a 4-Wall Cubicle

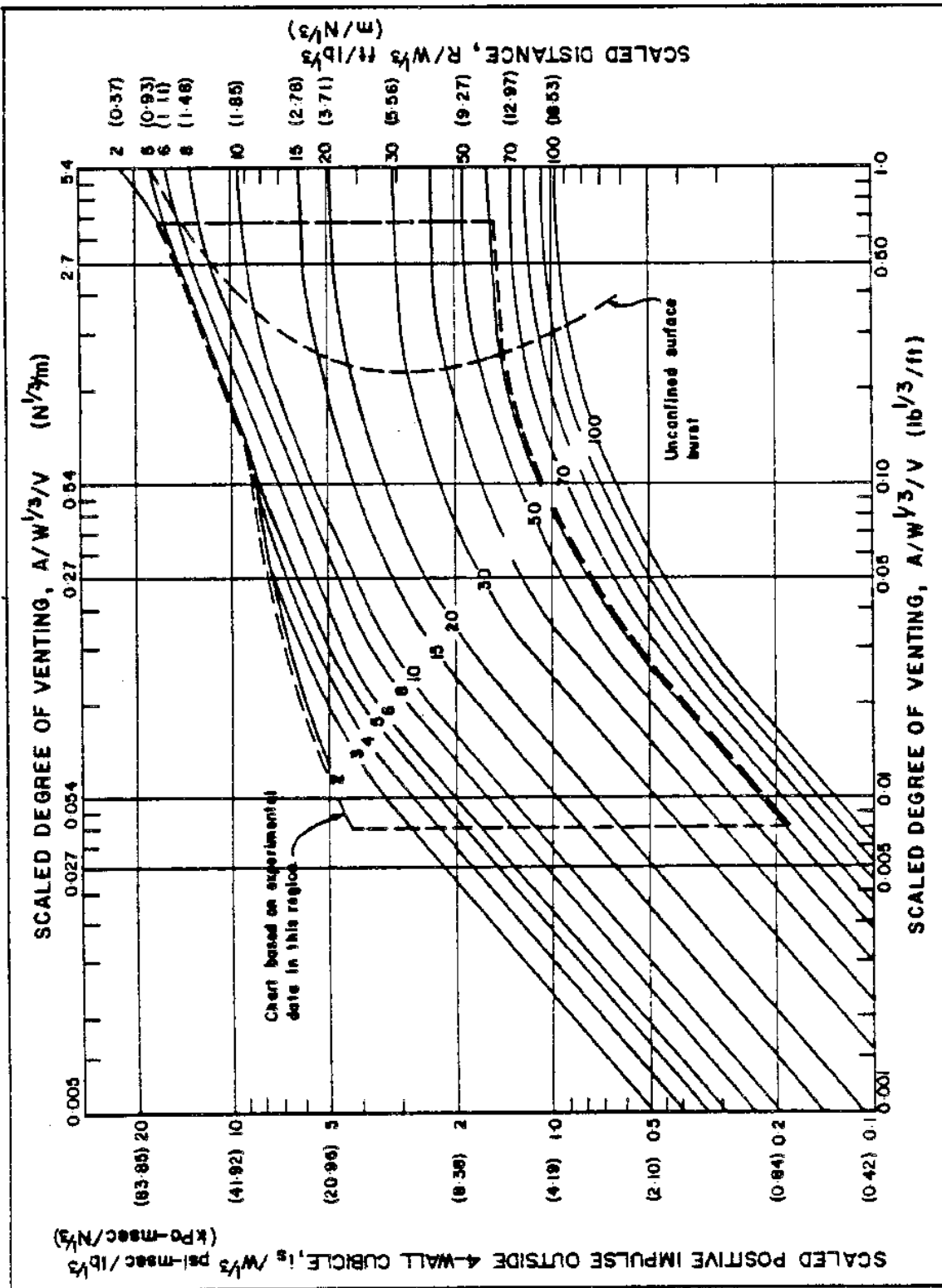

FIGURE 12

Design Chart for Vent Area Required to Limit Positive Impulse at any Range Outside a 4-Wall Cubicle

b. Interior Blast Loadings. Methods of calculating the average blast impulse on the walls and roofs of fully vented cubicles of various sizes and configurations are presented in NAVFAC P-397. The general procedure in predicting the impulse involves selecting the particular configuration of the cubicle from the 180 different cases listed in NAVFAC P-397 (such as the number of reflecting surfaces, charge position in cubicles, volume of cubicle and standoff distance). Usually, interpolation is required for one or more of the parameters which define a given situation. However, a computer program has been developed which executes the interpolation procedure using numerical tables equivalent to Figures 4-17 through 4-62 in NAVFAC P-397. Section 8 of this manual provides more information on the availability of the computer program.

c. Exterior Blast Environment. Several tests were performed in cubicle structures where the length (L) to height (H) ratio of the back walls was approximately equal to 1.0, while the charge weight-to-volume ratio varied between 0.2 and 2.0. The pressure-distance data is presented in Figure 4-63 of NAVFAC P-397. For large charge weights-to-structure ratios, the pressure-distance relationships in all directions from the structures will approach that for an unconfined surface explosion. Another investigation was performed by Keenan and Tancreto on 3-wall cubicles with and without roofs. The data obtained by the two investigations on the blast environment outside such cubicles are presented in the following paragraphs.

(1) Three-Wall Cubicle Without Roof. For a charge located at the geometric center of a 3-wall cubicle, the envelope curves for the peak pressures behind each wall of the cubicle are plotted as a function of scaled distances in Figure 13. The peak pressure, $(P_{\Gamma SO})_{\Gamma max}$, is also plotted as a function of W/V in Figure 14. Figure 11 should be used in conjunction with Figure 14. In some cases (small values of $R/W^{1/3}$ or W/V), $P_{\Gamma SO}$ from Figure 13 will exceed $(P_{\Gamma SO})_{\Gamma max}$ from Figure 14. In these cases, $(P_{\Gamma SO})_{\Gamma max}$ is the maximum peak pressure outside the cubicle.

(2) Three-Wall Cubicle with Roof. The envelope of peak pressures outside a 3-wall cubicle with a non-frangible roof is shown in Figure 15. At any scaled distance, there is no clear influence of cubicle geometry or W/V on the peak pressures out the open front; therefore, the curves apply to all values of W/V. As stated in paragraph 6.c.(1), $P_{\Gamma SO}$ should not exceed $(P_{\Gamma SO})_{\Gamma max}$ obtained from Figure 14.

d. Design Loads. Some criteria are outlined in Figures 16 and 17 for predicting the design loading in and around fully and partially vented cubicles. Some engineering judgment is required in using these figures.

7. AIRBLAST FROM UNDERWATER EXPLOSIONS.

a. Predicting Parameters of a Shock Wave. Figures 4-5 and 4-12 of NAVFAC P-397 provide a means of predicting the peak pressures, impulses, velocities, and other parameters of a shock wave for a bare spherical TNT explosive charge detonated in free air and on or very near ground surface. These parameters change, however, if the explosion occurs under shallow water. A portion of the work done by M.M. Swisdak is reproduced here. A detailed description of the work is provided in the report titled Explosion Effects and Properties: Part 1, Explosion Effects in Air, NSWC/WOL TR-116.

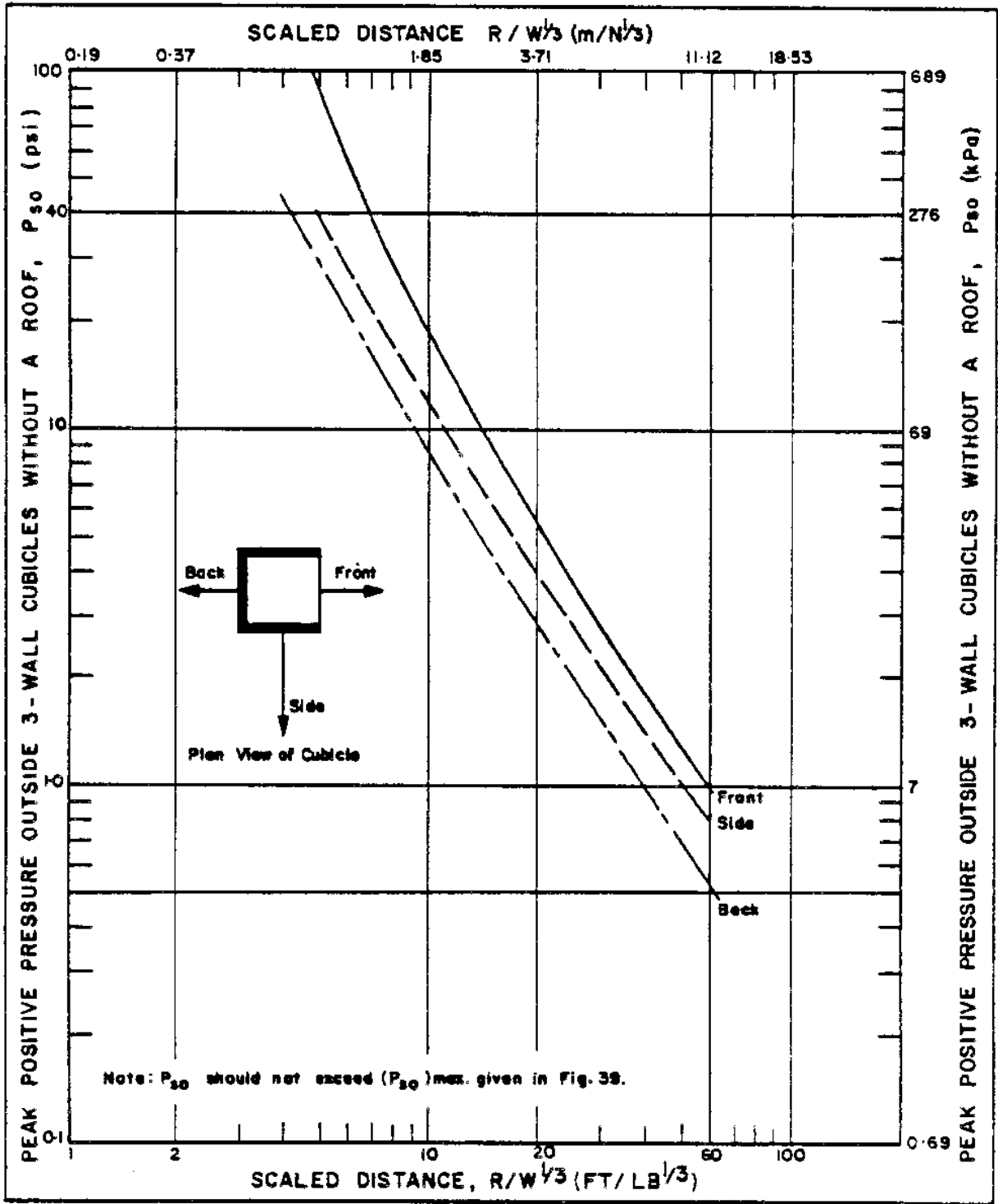

FIGURE 13
Envelope Curves for Peak Positive Pressure
Outside 3-Wall Cubicles Without a Roof

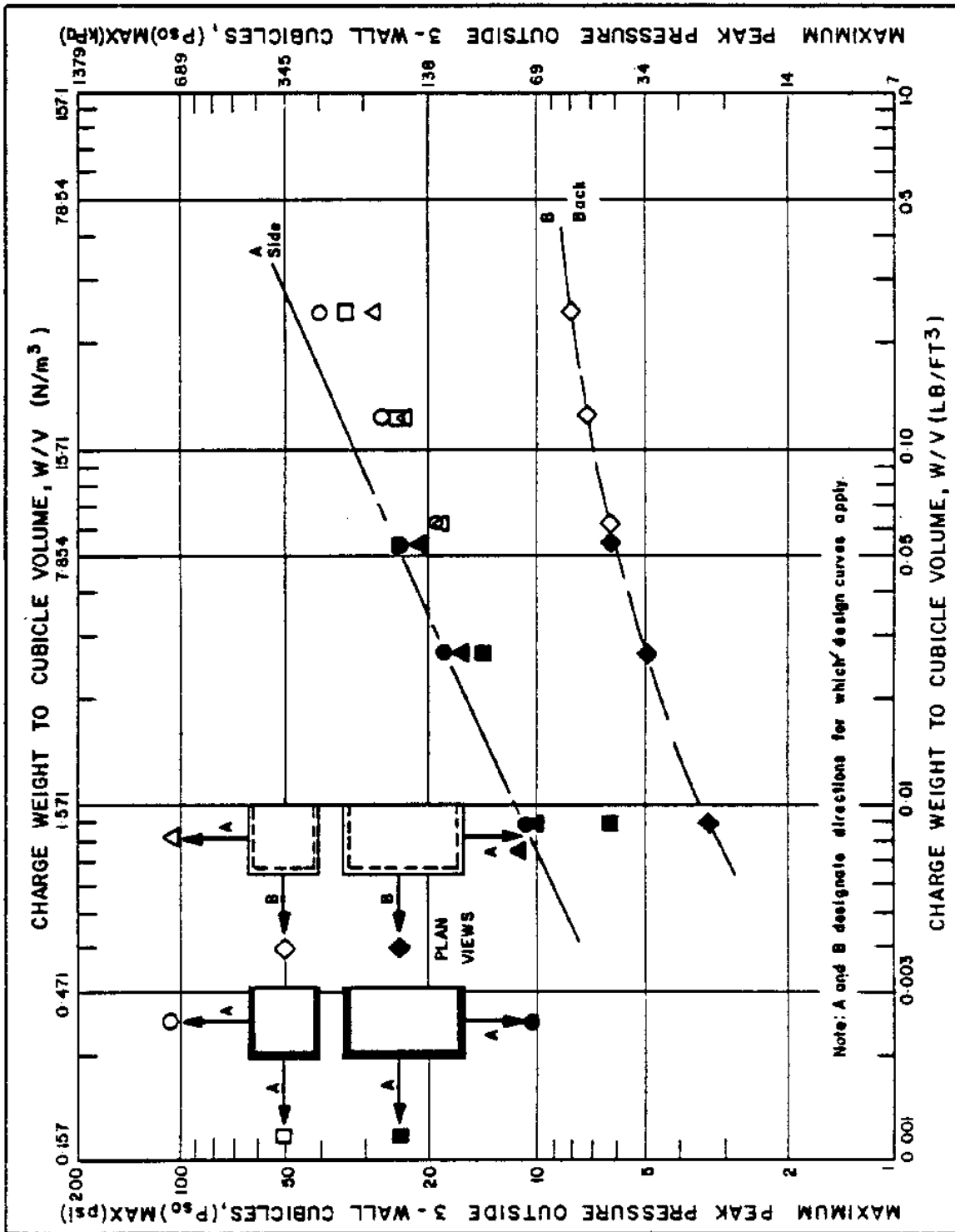

FIGURE 14
Envelope Curves for Maximum Peak Pressure Outside 3-Wall Cubicles

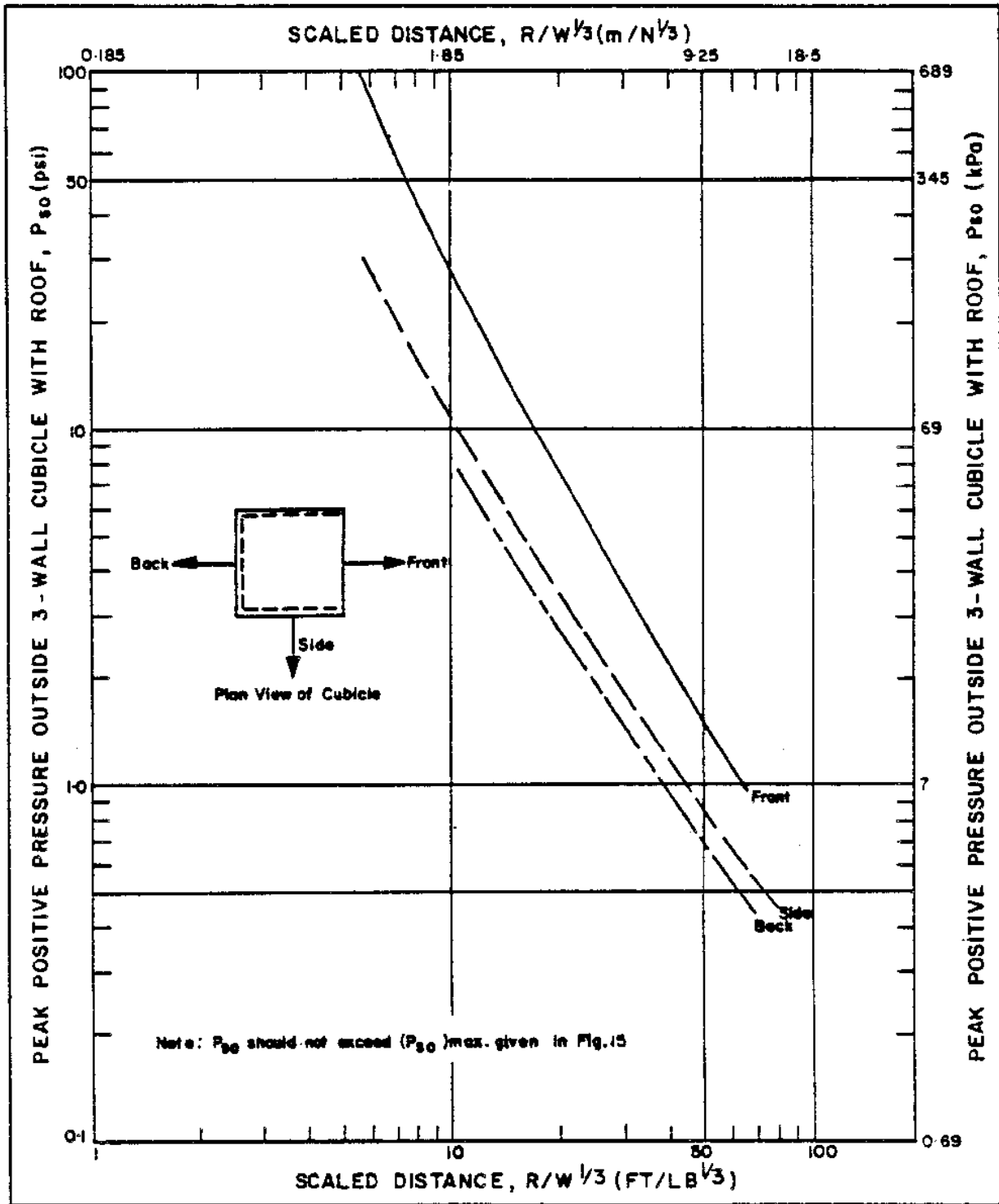

FIGURE 15

Envelope Curves for Peak Positive Pressure
Outside 3-Wall Cubicles with a Roof

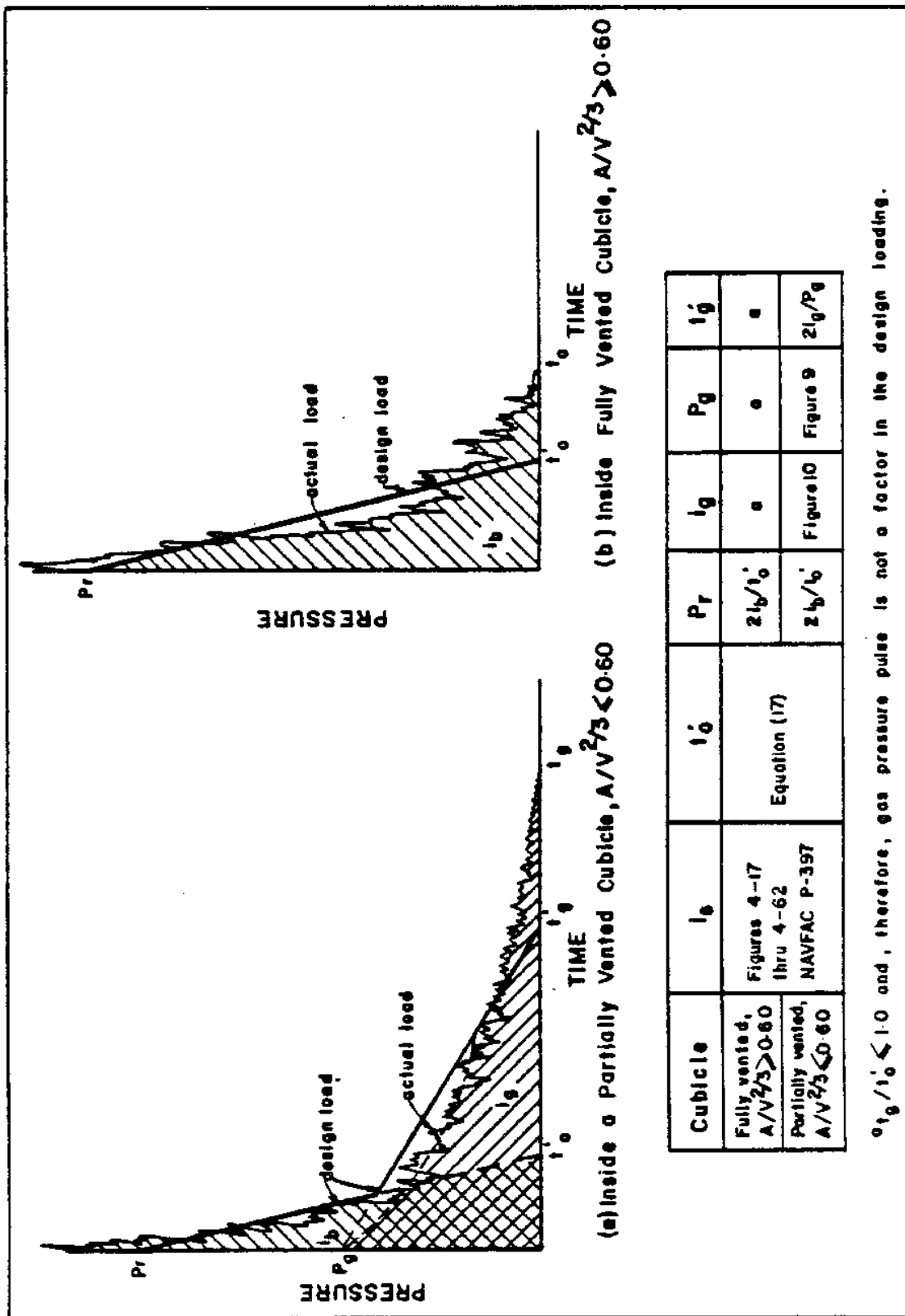

FIGURE 16
Proposed Criteria for Design Loading Inside Fully and Partially Vented Cubicles

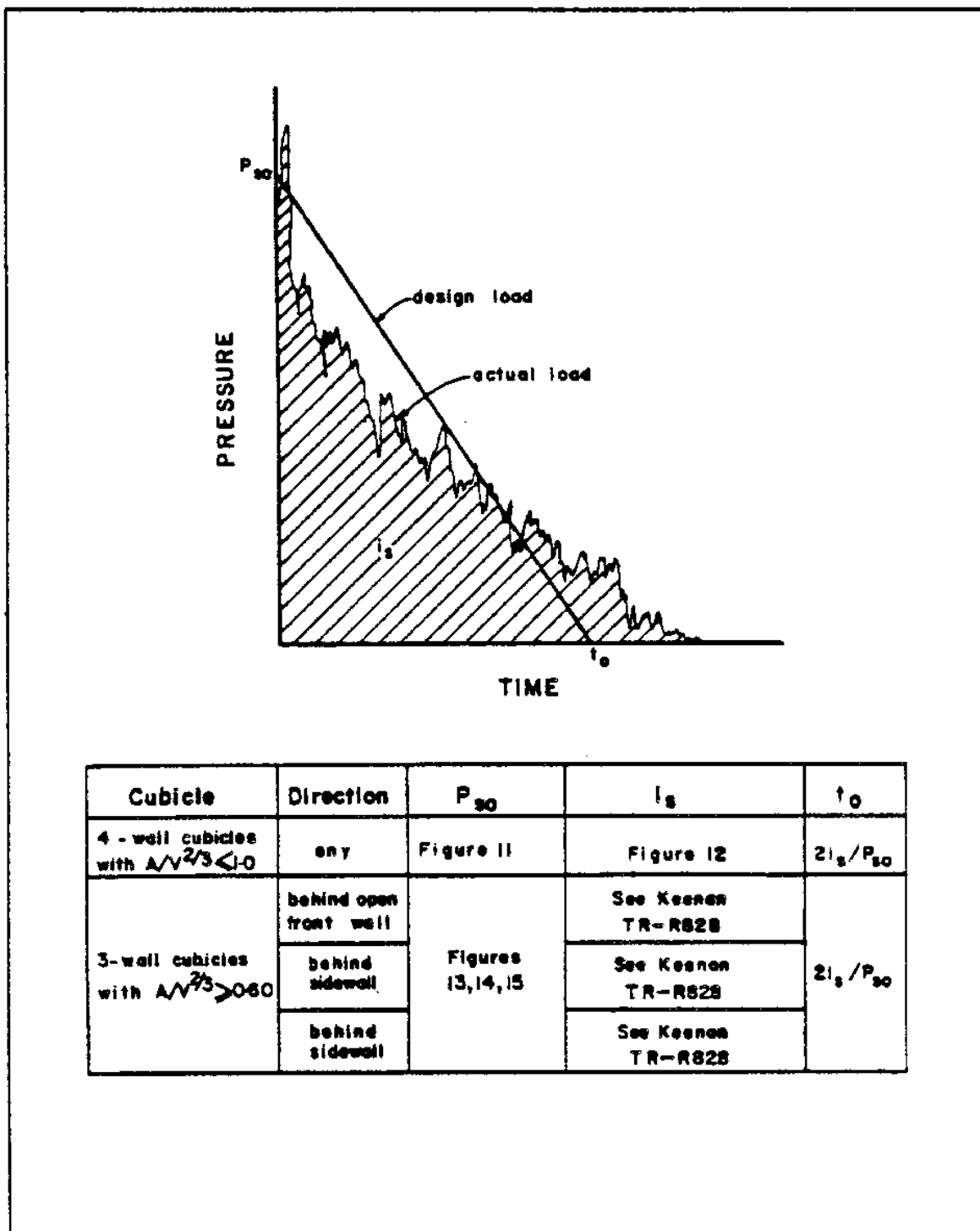

FIGURE 17
Proposed Criteria for Design Loading Outside Fully and Partially Vented Cubicles

b. Configuration of Charge and Interpretation of Different Parameters. Figure 18 shows the configuration of the charge and the interpretation of the different parameters required for the data presented in this section. Figures 19 through 24 present the blast pressure data as fixed functions of $[\lambda]_{\gamma}$, with values of $[\lambda]_{\gamma}$ varying between 0.25 and 40. Because of the scatter in the experimental pressure data used to construct Figures 19 through 24 and the uncertainties involved in making the necessary extrapolations, the curves in this section should be considered accurate only to within +/-30 percent. The following parameters are used in the aforementioned figures:

$$[\lambda]_{\gamma d} = d/W^{1/3}, \text{ scaled charge depth}$$

$$[\lambda]_{\gamma x} = R/W^{1/3}, \text{ scaled horizontal distance}$$

$$[\lambda]_{\gamma y} = y/W^{1/3}, \text{ scaled vertical distance}$$

8. EXTERNAL BLAST LOADS ON STRUCTURES

a. Forces Acting on Structures. The blast wave generated by an explosion in air is characterized by its transmission velocity, U ; by a peak incident pressure, P_{i0} ; by a positive phase duration, t_{p0} ; and by a specific impulse, i_{s0} . For each pressure range, there is a particle or wind velocity associated with the blast wave that causes a dynamic pressure on objects in the path of the wave. The values of the peak dynamic pressure, q_{p0} , vs. peak incident pressure are shown in Figure 4-66 of NAVFAC P-397.

b. Calculating Durations of Positive and Negative Pressure Phases. For design purposes, it is necessary to establish the variation or decay of both the incident and dynamic pressures with time, since the effects on a structure subjected to a blast loading depend upon the intensity-time history of the loading as well as on the peak intensity. Equations are provided in Chapter 4, Section V of NAVFAC P-397 to be used in calculating the durations of the positive and negative pressure phases. However, the rise time for the negative pressure should be taken as one-third of its duration, not one-eighth as recommended in NAVFAC P-397.

c. Aboveground Rectangular Structures. The interaction of an incident blast wave with an object is a complicated process and to reduce the complex problem of blast to reasonable terms, it will be assumed here that:

1. The structure is generally rectangular in shape;
2. The incident pressure is in the order of 200 psi or less; and
3. The object being loaded is in the region of the Mach reflection (NAVFAC P-397).

(1) Front Wall. For a rectangular aboveground structure at low pressure ranges, the variation of pressure with time on the side facing the detonation is illustrated in Figure 4-63 of NAVFAC P-397. When the incident wave interacts with the structure's front wall, the pressure is immediately raised from zero to the reflected pressure, P_{r0} , which is a function of the incident pressure and the angle of incidence between the shock front and the structure face. The time required to relieve the reflected pressures and the pressure acting on the front wall after this time can be calculated using Equations 4-5 and 4-6 of NAVFAC P-397, respectively.

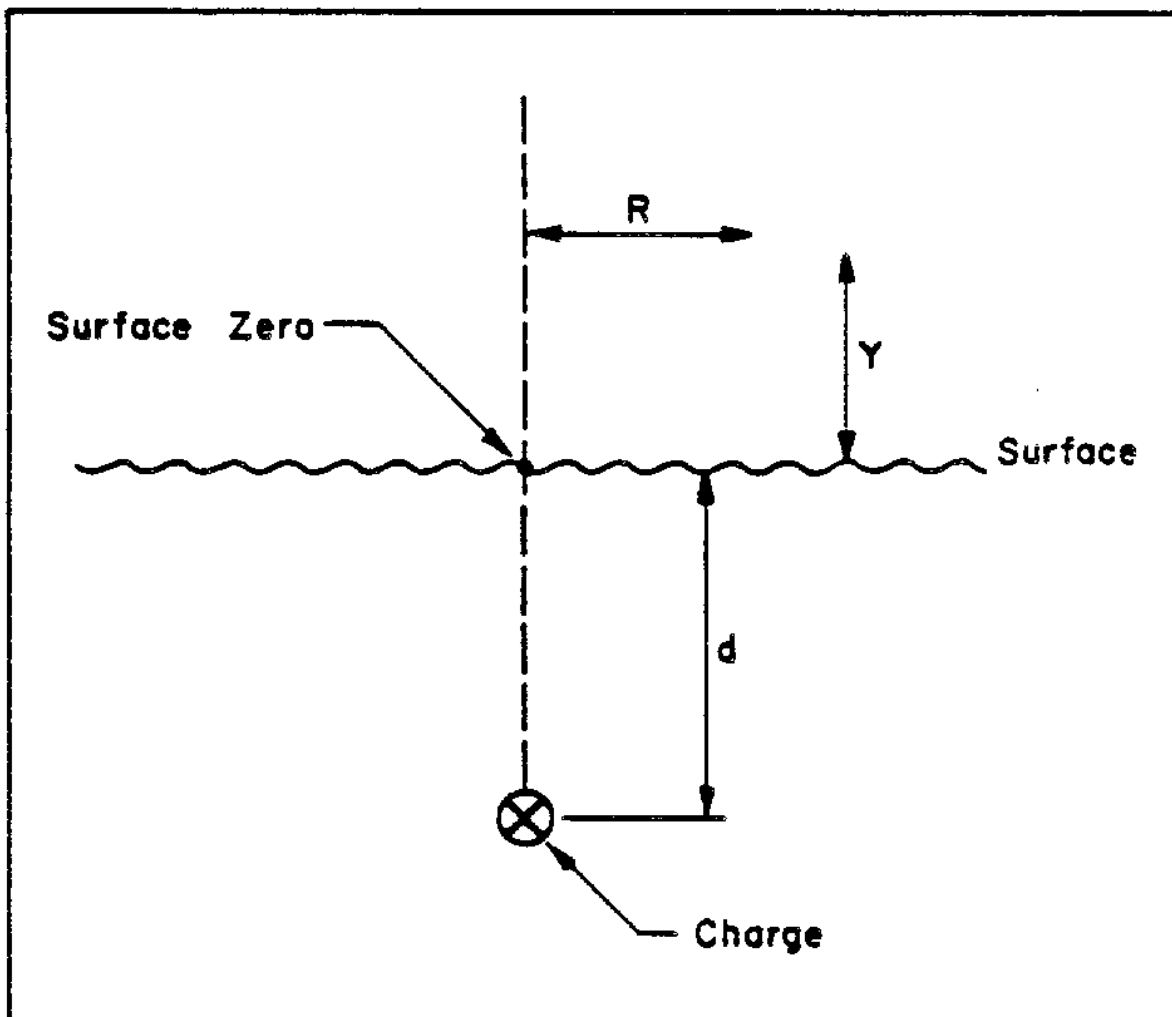
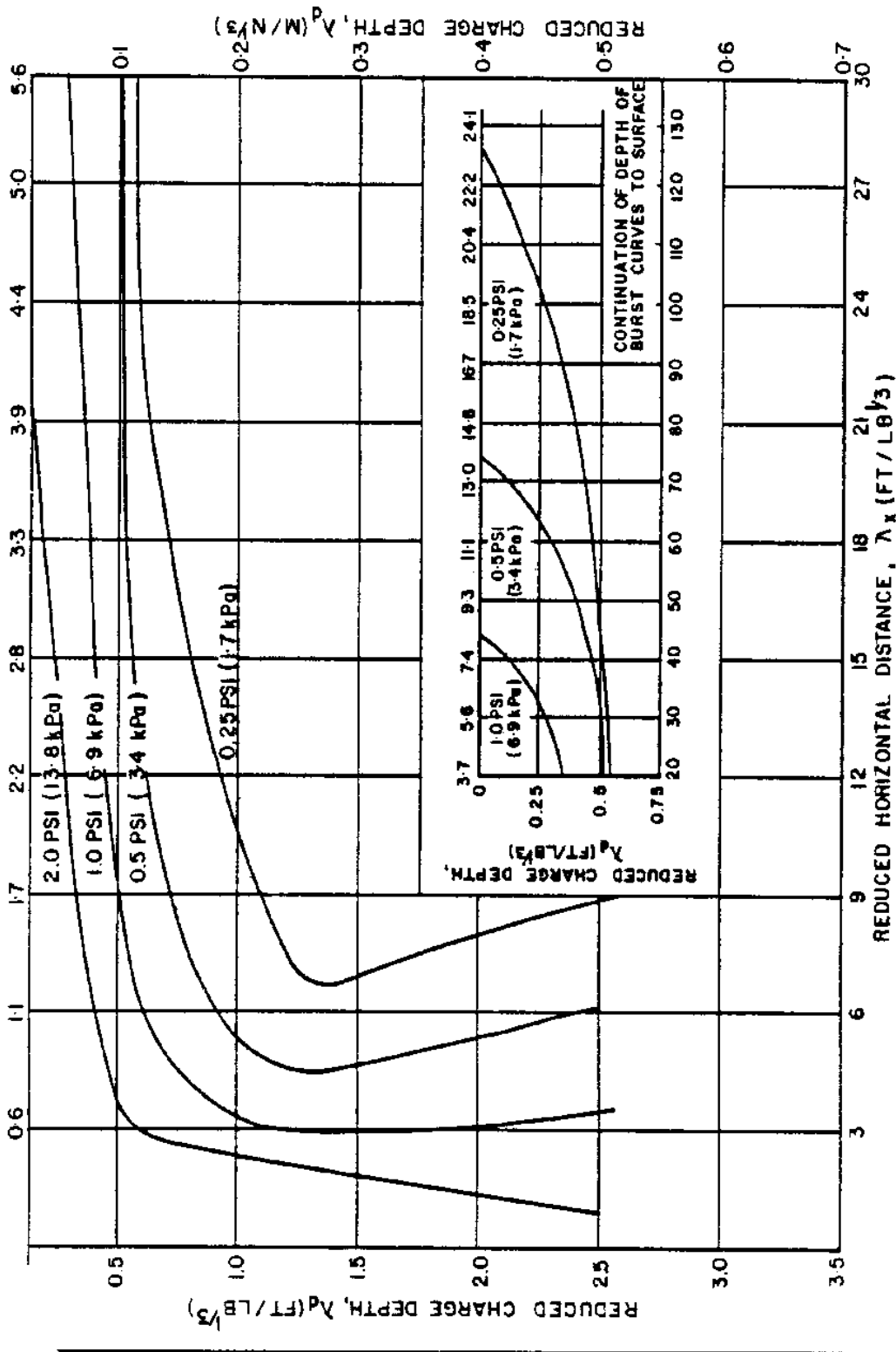

FIGURE 18
Charge Configuration



CONSTANT AIR BLAST PRESSURES ALONG A LINE PARALLEL TO THE WATER SURFACE FROM TNT SPHERES FIRED UNDERWATER, λ_y FIXED AT 0.25

FIGURE 19

Airblast from Underwater Explosions
 λ_y Fixed at 0.25

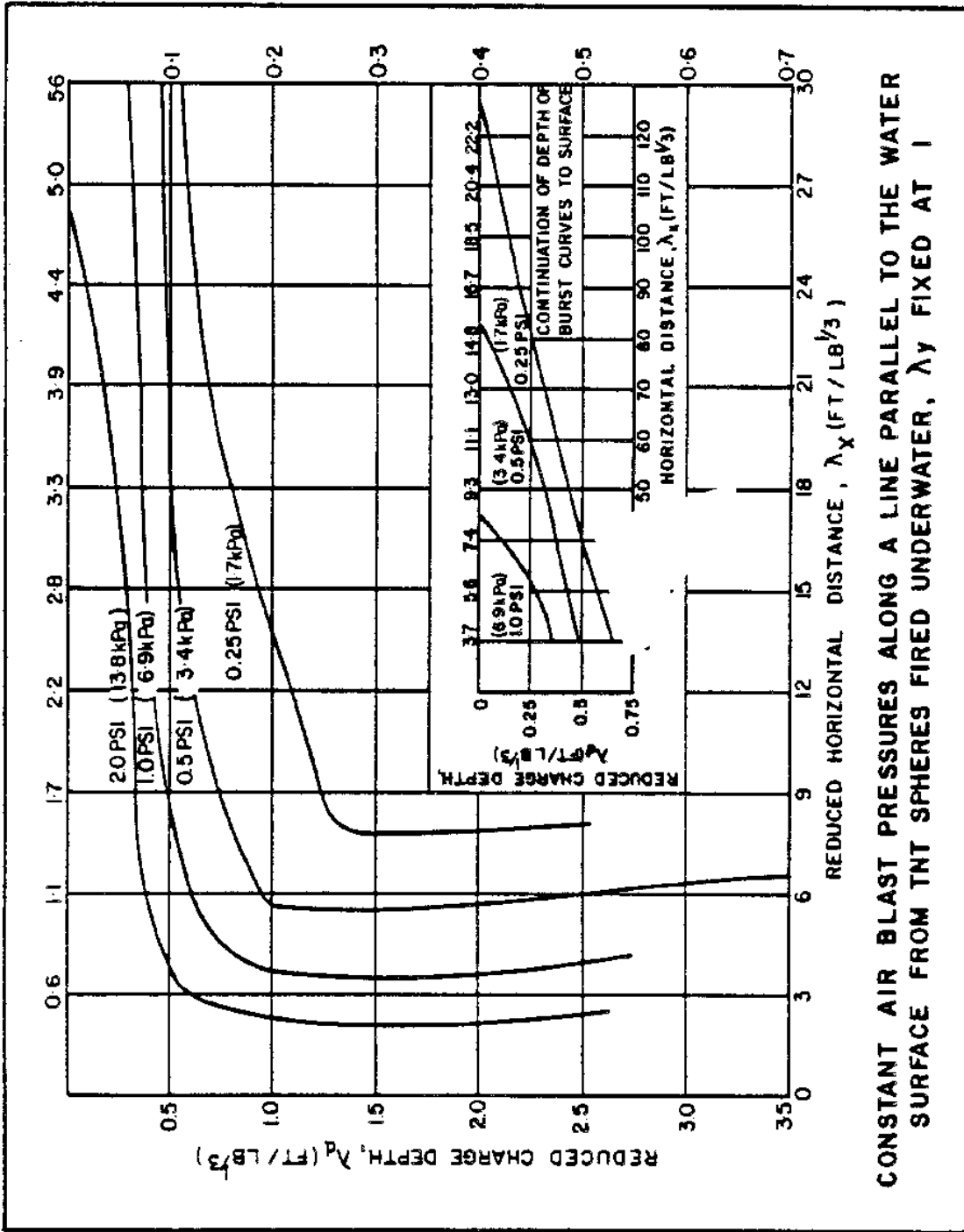

CONSTANT AIR BLAST PRESSURES ALONG A LINE PARALLEL TO THE WATER SURFACE FROM TNT SPHERES FIRED UNDERWATER, λ_y FIXED AT 1

FIGURE 20
Airblast from Underwater Explosions
 λ_y Fixed at 1

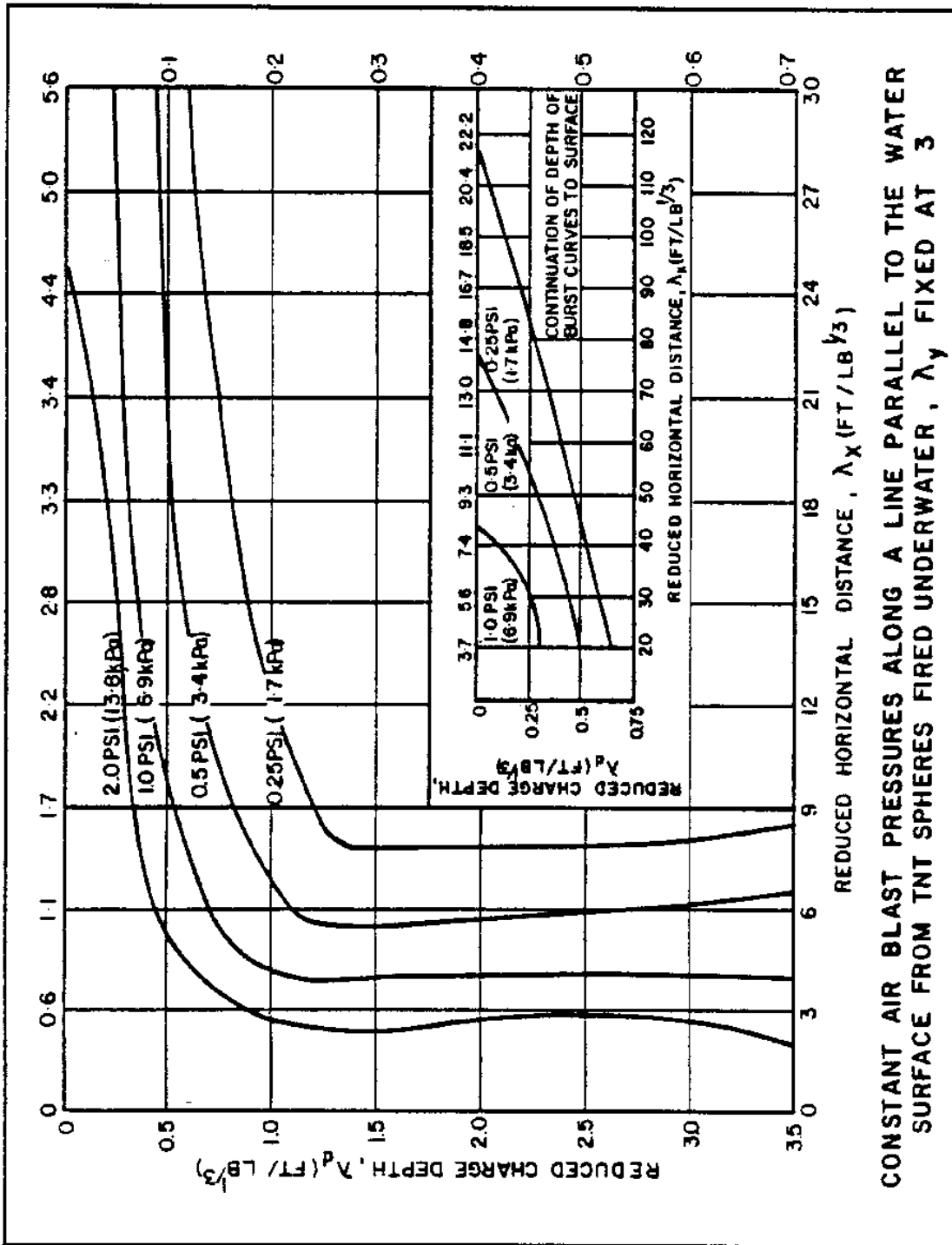

CONSTANT AIR BLAST PRESSURES ALONG A LINE PARALLEL TO THE WATER SURFACE FROM TNT SPHERES FIRED UNDERWATER, λ_y FIXED AT 3

FIGURE 21
Airblast from Underwater Explosions
 λ_y Fixed at 3

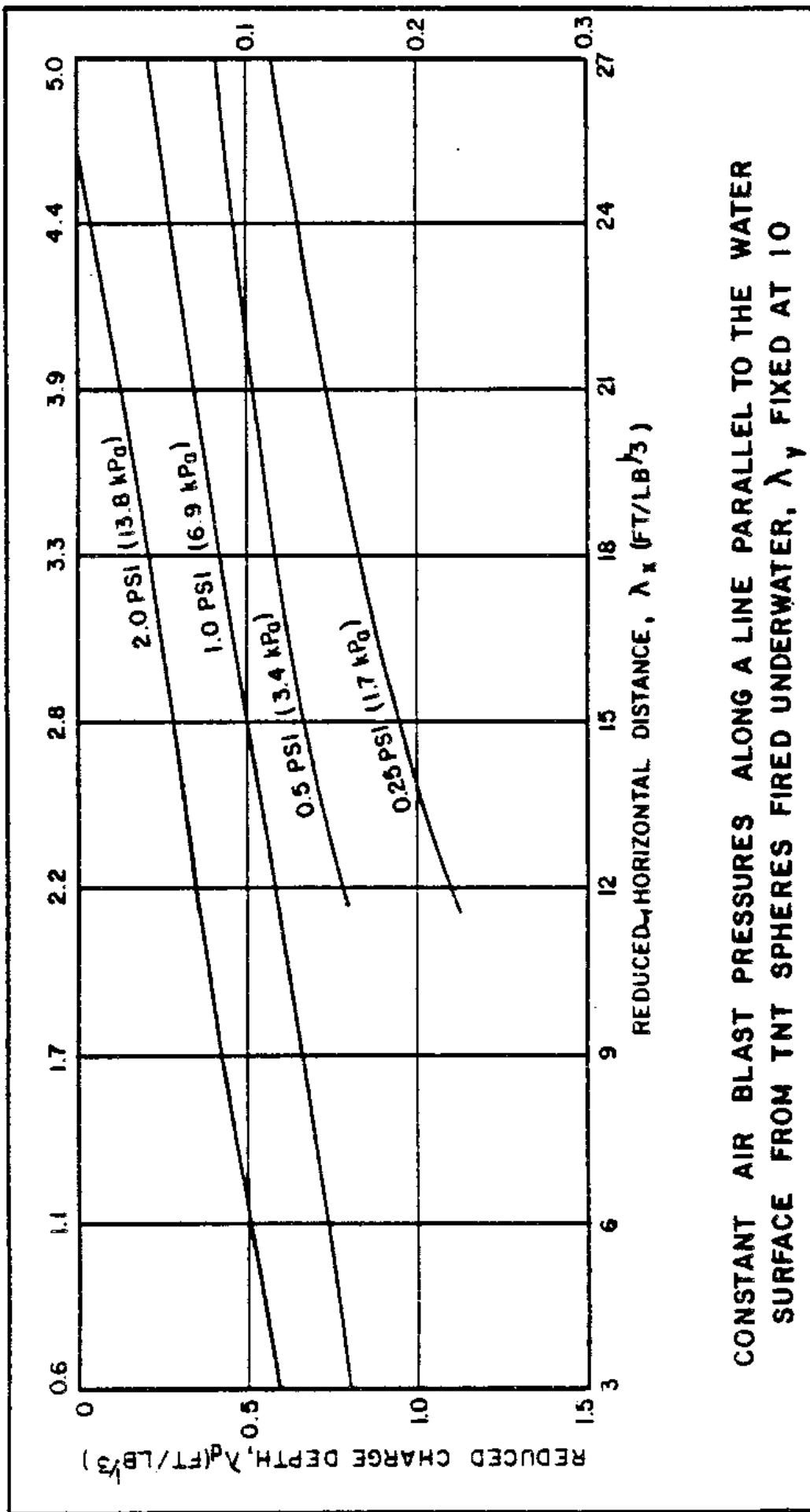

CONSTANT AIR BLAST PRESSURES ALONG A LINE PARALLEL TO THE WATER SURFACE FROM TNT SPHERES FIRED UNDERWATER, λ_y FIXED AT 10

FIGURE 22
Airblast from Underwater Explosions
 λ_y Fixed at 10

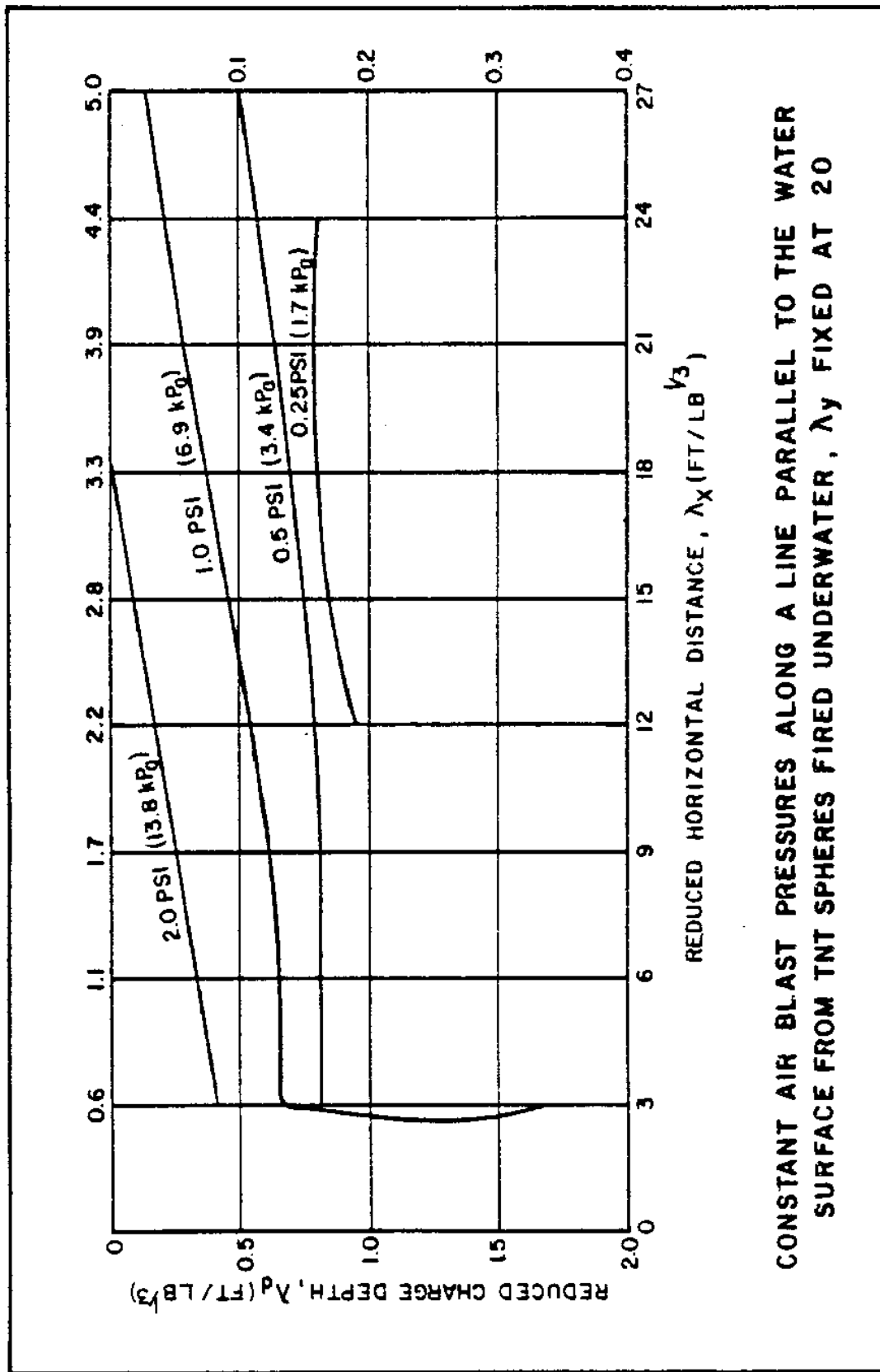
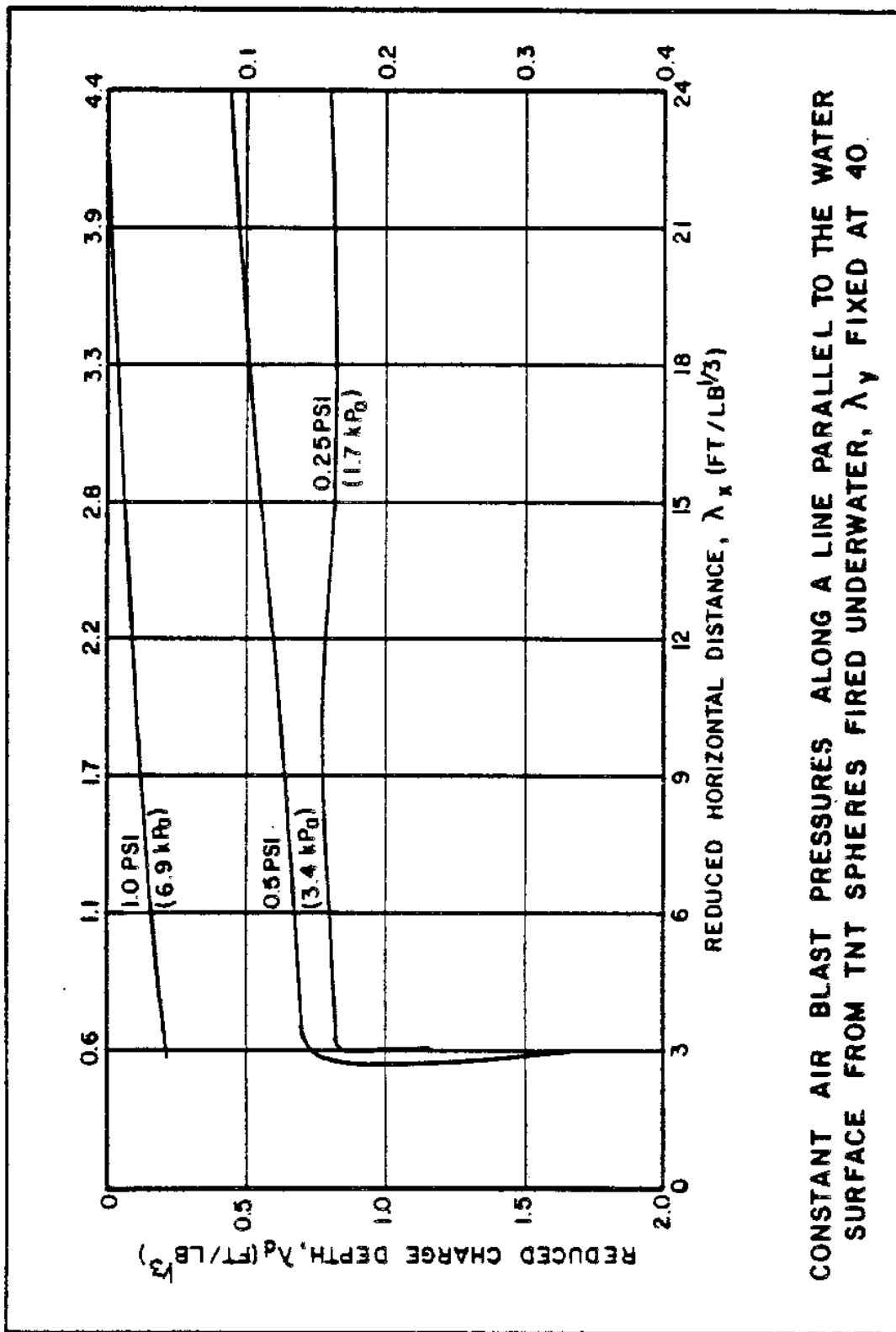

FIGURE 23
Airblast from Underwater Explosions
 λ_y Fixed at 20



CONSTANT AIR BLAST PRESSURES ALONG A LINE PARALLEL TO THE WATER SURFACE FROM TNT SPHERES FIRED UNDERWATER, λ_y FIXED AT 40.

FIGURE 24
Airblast from Underwater Explosions
 λ_y Fixed at 40

(2) Roof and Side flail. In calculating the pressures on the roof and side walls of a structure, a step-by-step analysis of the wave propagation should be made. However, because of the complexity of such an analysis, an approximate method of calculating the pressure-time history is outlined in Chapter 4, Section V of NAVFAC P-397.

(3) Rear Wall. In most design cases, the primary reason for determining the blast loads acting on the rear wall is to determine the overall drag effects on the building. The recommendations outlined in Chapter 4 of NAVFAC P-397 should be followed for local design of the rear wall. However, for analyses of frames and similar structures, it is recommended that the positive phase blast loads acting on the rear wall of a structure be taken equal to 60 percent of the incident overpressure. This is true for incident pressures of approximately 10 psi or less. For higher pressures, the procedures of NAVFAC P-397 should be followed for both the design and analysis of rear walls.

9. PRESSURE INCREASE WITHIN A STRUCTURE. Leakage of pressures through any openings in a structure occurs when such a structure is engulfed by a blast wave. The interior of the structure experiences an increase in its ambient pressure in a time that is a function of the structure's volume, area of openings, and applied exterior pressure and duration. A method of determining the average pressure inside the structure is outlined in Section VI, Chapter 4 of NAVFAC P-397 and also in the report Accidental Explosions and Effects of Blast Leakage into Structures by Kaplan and Price.

10. MULTIPLE EXPLOSIONS.

a. Blast Characteristics. The blast characteristics of a multiple explosion can be very different from that measured for a single charge or one of separated charges. The pressure-time relationships will depend upon the interaction of the individual waves themselves. A minimum amount of theoretical and experimental data is available to characterize blast waves from multiple detonations. A good source of information on this subject is the text by Zaker, Blast Pressures from Sequential Explosions.

b. Blast Loading on Side Walls of a Cubicle Due to Simultaneous Explosions. A procedure for determining the blast loading on side walls of a cubicle due to simultaneous explosions is outlined in Keenan's Class Notes. It should be emphasized that the impulses calculated by this procedure will be conservative. Other sources of information on this matter are; Blast Effects of Simultaneous Multiple Charge Detonations by Horkanson, High Explosive Multi-Burst Air Blast Phenomena (Simultaneous and Non-Simultaneous Detonations) by Reisler, et al., and The Air Blast from Simultaneously Detonated Explosive Spheres by Armendt, et al.

11. PRIMARY FRAGMENTS.

a. Initial Fragment Velocities. The most common method for calculating the initial velocity of fragments resulting from the detonation of cased explosives is the Gurney method described in the reports The Initial Velocities of Fragments from Bombs, Shells and Grenades and The Mass Distribution of Fragments from Bombs, Shells and Grenades. The report by Healey, et al., Primary Fragment Characteristics and Impact Effects on Protective Barriers, presents an in-depth discussion of primary fragment characteristics and part of this report is reproduced here.

Assuming an evenly distributed charge and uniform casing wall thickness, the following expression was developed for the initial fragment velocity resulting from the detonation of a cylindrical container:

$$\text{EQUATION: } V_{f0} = (2E')^{1/2} [W/W_c] / (1 + 0.5W/W_c)^{1/2} \quad (21)$$

where,

$$\begin{aligned} (2E')^{1/2} &= \text{Gurney's energy constant, fps} \\ W &= \text{weight of explosive (oz). In design calculations, } W \\ &= 1.2 \text{ times the actual explosive weight, as discussed} \\ &\text{in paragraph 2 of this section.} \\ W_c &= \text{weight of casing, oz} \\ V_{f0} &= \text{initial velocity of fragment, fps} \end{aligned}$$

(1) Figure 25 shows the variation of the normalized quantity $V_{f0} / (2E')^{1/2}$, with W/W_c for this case. Table 2 contains expressions for the initial velocity for other configurations. This table also contains expressions for the velocity which is approached as a limit with increasing values of the W/W_c ratio.

(2) An alternate fragment velocity expression was derived by R.I. Mott, A Theoretical Formula for the Distribution of Weights of Fragments, which gives a lower value for initial velocity than that predicted by Gurney's equation. Therefore, for design purposes it is conservative to base initial velocity calculations upon the Gurney equation.

b. Variation of Fragment Velocity with Distance. The primary concern for design purposes is the velocity with which the fragment strikes the protective structure. At very short distances from the detonation (about 20 feet), the striking velocity can be assumed to be equal to the initial velocity. However, taking into account the effects of drag, air density, and shape-to-weight relationship, the striking velocity can be expressed as:

$$\text{EQUATION: } V_{fs} = v_{f0} e^{-k_v R} \quad (22a)$$

where,

$$\begin{aligned} V_{fs} &= \text{fragment velocity at a distance } R \text{ from the center of the} \\ &\text{detonation, fps} \\ V_{f0} &= \text{initial velocity of fragment, fps} \\ R &= \text{distance from the detonation to the protective structure, ft} \\ k_v &= \text{velocity decay coefficient} = (A/W_c) \rho a C_D \end{aligned}$$

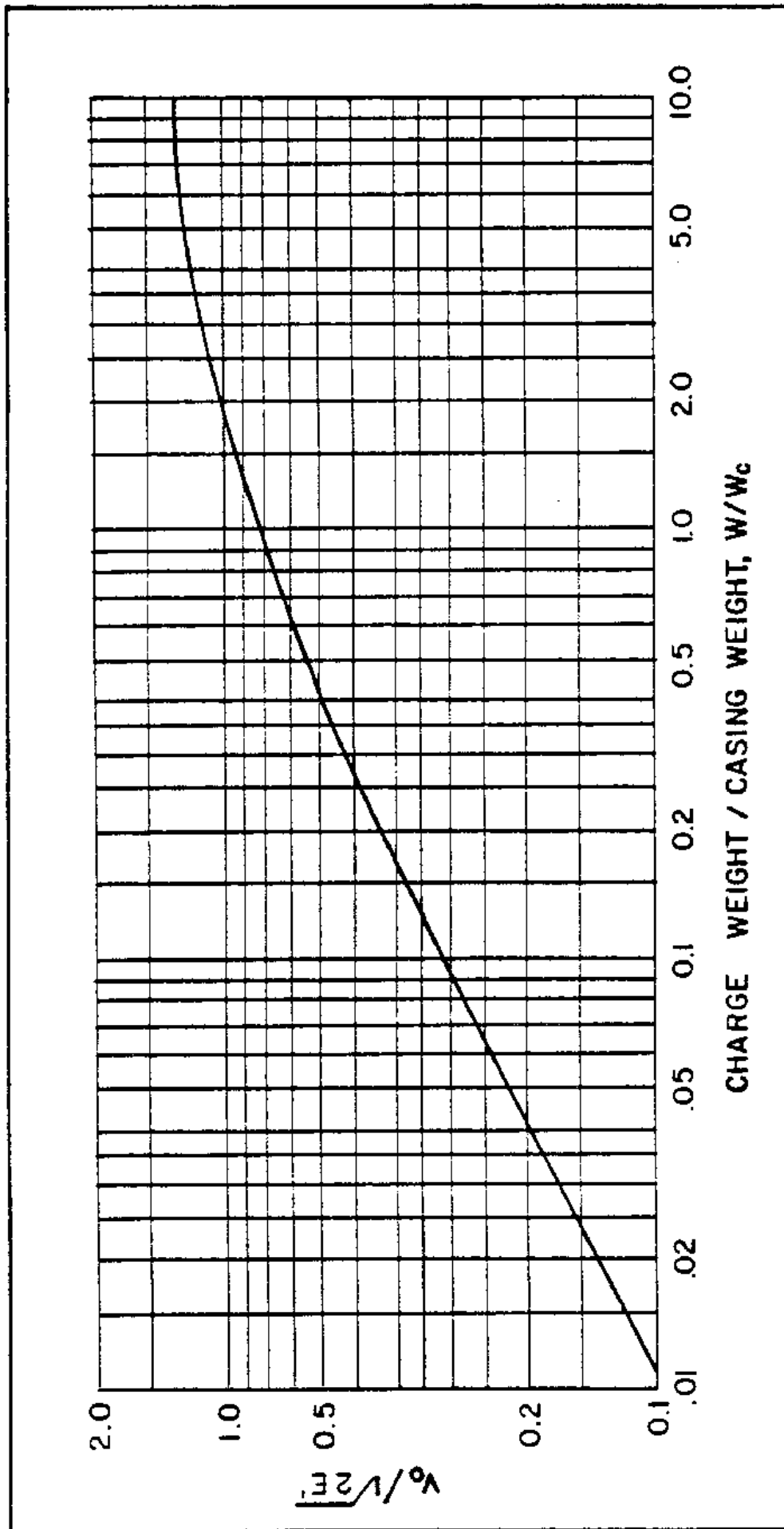

FIGURE 25
Initial Velocity of Primary Fragments for Cylindrical Casing

TABLE 2
Initial Velocity of Primary Fragments

Type	Diagrammatic shape	Initial fragment velocity =	Medium	Remarks
Cylinder		$\sqrt{2E} \left[\frac{\frac{W}{W_c}}{1 + \frac{W}{3W_c}} \right]^{1/2}$	$\sqrt{2E} \sqrt{3}$	
Sphere		$\sqrt{2E} \left[\frac{\frac{W}{W_c}}{1 + \frac{3W}{4W_c}} \right]^{1/2}$	$\sqrt{2E} \sqrt{1}$	
Steel cased cylinder		$\sqrt{2E} \left[\frac{\frac{W}{W_c}}{1 + \frac{(2+\alpha)W}{8(1+\alpha)W_c}} \right]^{1/2}$ where $\alpha = \frac{d_1}{d_2}$	$\sqrt{2E} \sqrt{\frac{8(1+\alpha)}{8(1+\alpha)}}$	If the steel case is many times more massive than the explosive, this expression for the initial velocity should be modified by multiplying it by the expression: $\sqrt{1 - \frac{0.02W_c}{W}}$ where W_c is the weight of the steel case (lbs).
Plate		$\sqrt{2E} \left[\frac{\frac{3W}{3W_c}}{1 + \frac{W}{3W_c} + \frac{6W}{3W_c}} \right]^{1/2}$	$\sqrt{2E} \sqrt{3}$	This expression applies for a rectangular explosive in contact with a metal plate having the same surface area. It is assumed that the entire system is expanded in free air and its thickness is small in comparison to its surface area so that the resulting remnants are essentially normal to the plane of the plate.
Hollow cylinder		-	-	Although an expression to predict the velocity of fragments is not available, an upper limit of the initial velocity may be obtained using the expression for a solid cylinder and a lower limit from the expression for a single plate. The ratio of the explosive weight to the casing weight (W/W_c) of the hollow cylindrical charge is used in both expressions.
Sandwich plates		$\sqrt{2E} \left[\frac{\frac{W}{W_c}}{W_c + W_c + \frac{W}{1-p+p^2}} \right]^{1/2}$ where $p = \frac{W_c}{W_c + W_c}$ $W_c = \frac{W}{2}$ $W_c = \frac{W}{2}$ $W_c = W_c + W_c$ $\sqrt{2E} \left[\frac{\frac{W}{2W_c}}{1 + \frac{W}{6W_c}} \right]^{1/2}$	$\sqrt{2E} \sqrt{3}$	The expression applies for a rectangular explosive sandwiched between two metal plates having the same surface area as the explosive. It is assumed that the entire system is expanded in free air and its thickness is small in comparison to its surface area so that the resulting remnants are essentially normal to the plane of the plates. NOTE: W = EXPLOSIVE WEIGHT W_c = CASING WEIGHT $W, W_c, W_{c0}, W_{c1}, W_{c2}$ (lbs) d_1, d_{c0} (lbs) $v_0, \sqrt{2E}$ (ft/sec)

$E, W_c, W_{c0}, W_{c1}, W_{c2}$ (lbs)
 d_1, d_{c0} (lbs)
 $v_0, \sqrt{2E}$ (ft/sec)

The decay coefficient can be evaluated:

- $A/W_f \gamma$ = fragment form factor, the ratio of the presented area of fragment (in^2) to the fragment weight (oz), which is taken as $0.78/(W_f \gamma)^{1/3}$ for random mild steel fragment produced by the detonation of a cased charge
- $[\rho] \gamma$ = density of air 0.00071 oz/ in^3
- $C_D \gamma$ = air drag coefficient of fragment, which from Healey's report is equal to 0.6 in the supersonic region (velocity > 1,125 fps)

The resulting expression for the striking velocity is as follows:

$$\text{EQUATION: } V_s = C_o e^{-0.004 R_f / W_f^{1/3}} \quad (22b)$$

The variation of primary fragment velocity with distance is shown in Figure 26.

c. Fragment Mass Distribution. Reliable estimates of the mass distribution of fragments from the casing of an explosive container can be obtained from the basic equation developed by Mott in A Theory of Fragmentation and by Gurney in The Mass Distribution of Fragments from Bombs. Shells and Grenades.

$$\text{EQUATION: } \ln N_f = \ln (C' M_A) - (W_f)^{1/2} / M_A \quad (23a)$$

where,

- N_f = the number of fragments with weight greater than the fragment weight, W_f
- C' = fragment distribution constant = $W_c / (2M_A^3)$
- W_c = total casing weight, oz
- t_c = average casing thickness, in
- d_i = average inside diameter of casing, in
- B = explosive constant (Table 3)
- W_f = fragment weight, oz
- M_A = fragment distribution parameter given by:

$$\text{EQUATION: } M_A = B t_o^{5/6} d_i^{1/3} (1 + t_c / d_i) \quad (23b)$$

(1) A number of important relationships and design equations can be obtained by expressing the Mott equation in the following form:

$$\text{EQUATION: } N_f = C' M_A e^{-(W_f)^{1/2} / M_A} \quad (24a)$$

or by substituting $C' = W_c / (2M_A^3)$

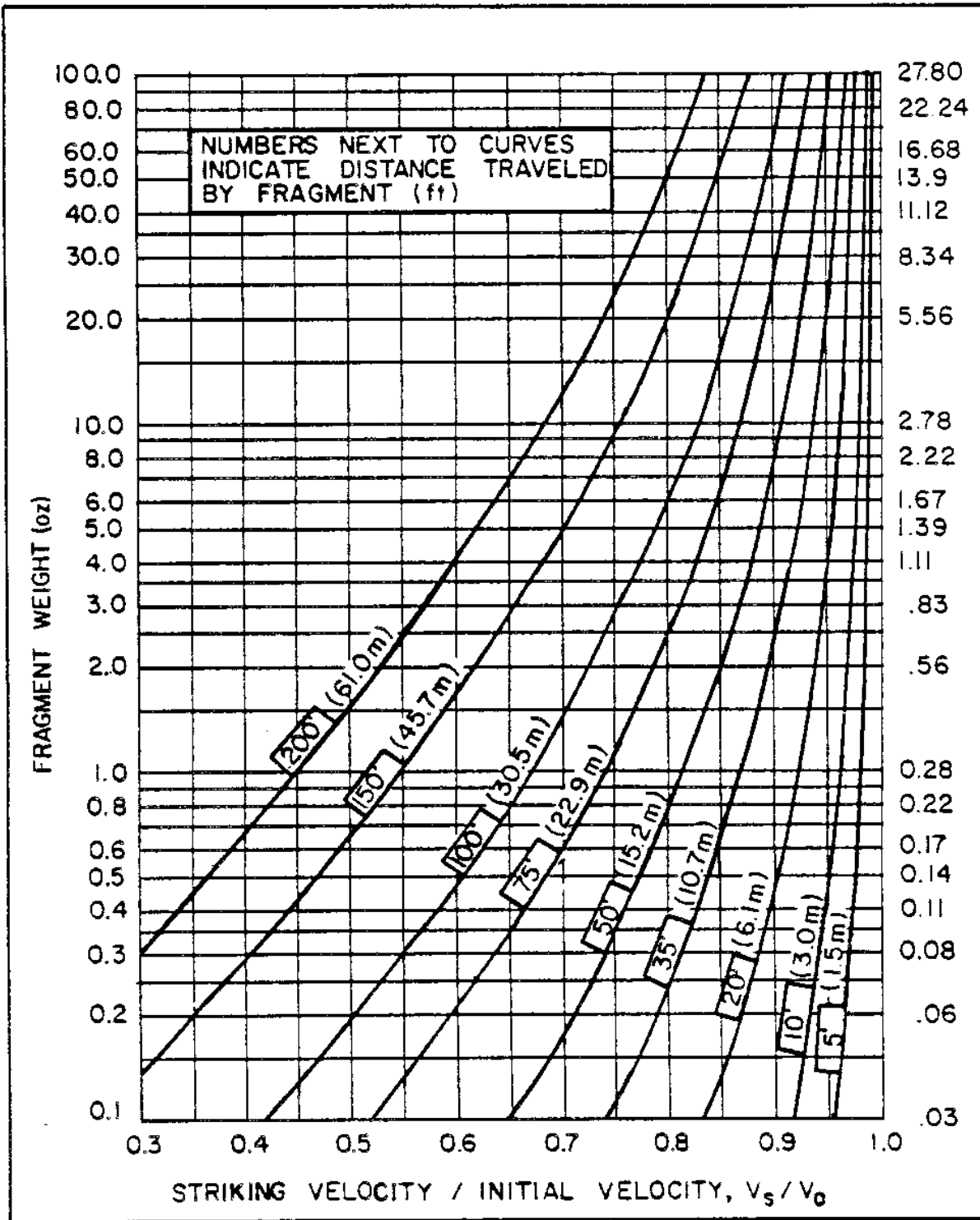

FIGURE 26
Variation of Primary Fragment Velocity with Distance

TABLE 3
Explosive Constants

Explosive Material	Gurney energy constant ($2E'$) ^{1/2} (fps)	B (Explosive constant)
Amatol	(6,190) [*]	0.35
Composition B	7,880	-
H-6	7,710	0.28
Hexanite	(6,850) [*]	0.32
Pentolite	7,550	0.25
RDX/TNT (75/25)	7,850	-
RDX/TNT (70/30)	8,380	-
RDX/TNT (60/40)	7,880	0.27
TNT	6,940	0.30
Tetryl	7,460	0.24
Torpex	7,450	-

[*] These constants are conservative estimates derived from other explosive output data.

NOTE: The above constants are for mild steel cylindrical containers of uniform thickness.

$$\text{EQUATION: } N_f = [W_c e^{-(W_f)^{1/2}/M_A}] / 2M_A^2 \quad (24b)$$

Setting the fragment weight, W_f , equal to zero, the following expression for the total number of fragments, N_T , is obtained:

$$\text{EQUATION: } N_T = W_c / 2M_A^2 \quad (25)$$

Hence, the average particle weight \bar{W}_f can be found:

$$\text{EQUATION: } \bar{W}_f = W_c / N_T = 2M_A^2 \quad (26)$$

Equation (24b) can then be expressed as:

$$\text{EQUATION: } N_f = N_T e^{-(W_f)^{1/2}/M_A} \quad (27a)$$

or:

$$\text{EQUATION: } N_f / N_T = e^{-(W_f)^{1/2}/M_A} \quad (27b)$$

(a) The ratio of $N_{f \geq W_f} / N_T$ represents that fraction of the total number of fragments which have a weight greater than W_f . This relationship is shown schematically in Figure 27a and as a cumulative distribution function in Figure 27b.

(b) It is interesting to observe that the average fragment weight, $2M_A^2$, corresponds to an $N_{f \geq W_f} / N_T$ value of 0.243, indicating that $(1 - N_{f \geq W_f} / N_T) \cdot 100$ or 75.7 percent of all primary fragments generated by the detonation have a weight less than the overall average fragment weight. Hence, the Mott equation predicts the release of a continuous distribution of fragments ranging in size from a large number of lightweight particles to a small number of very heavy casing fragments.

(2) For design purposes a Confidence Level, CL, where $0 < CL < 1$, can be defined as the probability that the weight W_f is the largest weight fragment released. An expression can then be developed for the design fragment weight corresponding to a prescribed design confidence level:

$$\text{EQUATION: } CL = 1 - N_f / N_T = 1 - e^{-(W_f)^{1/2}/M_A} \quad (28a)$$

or:

$$\text{EQUATION: } e^{-(W_f)^{1/2}/M_A} = 1 - CL \quad (28b)$$

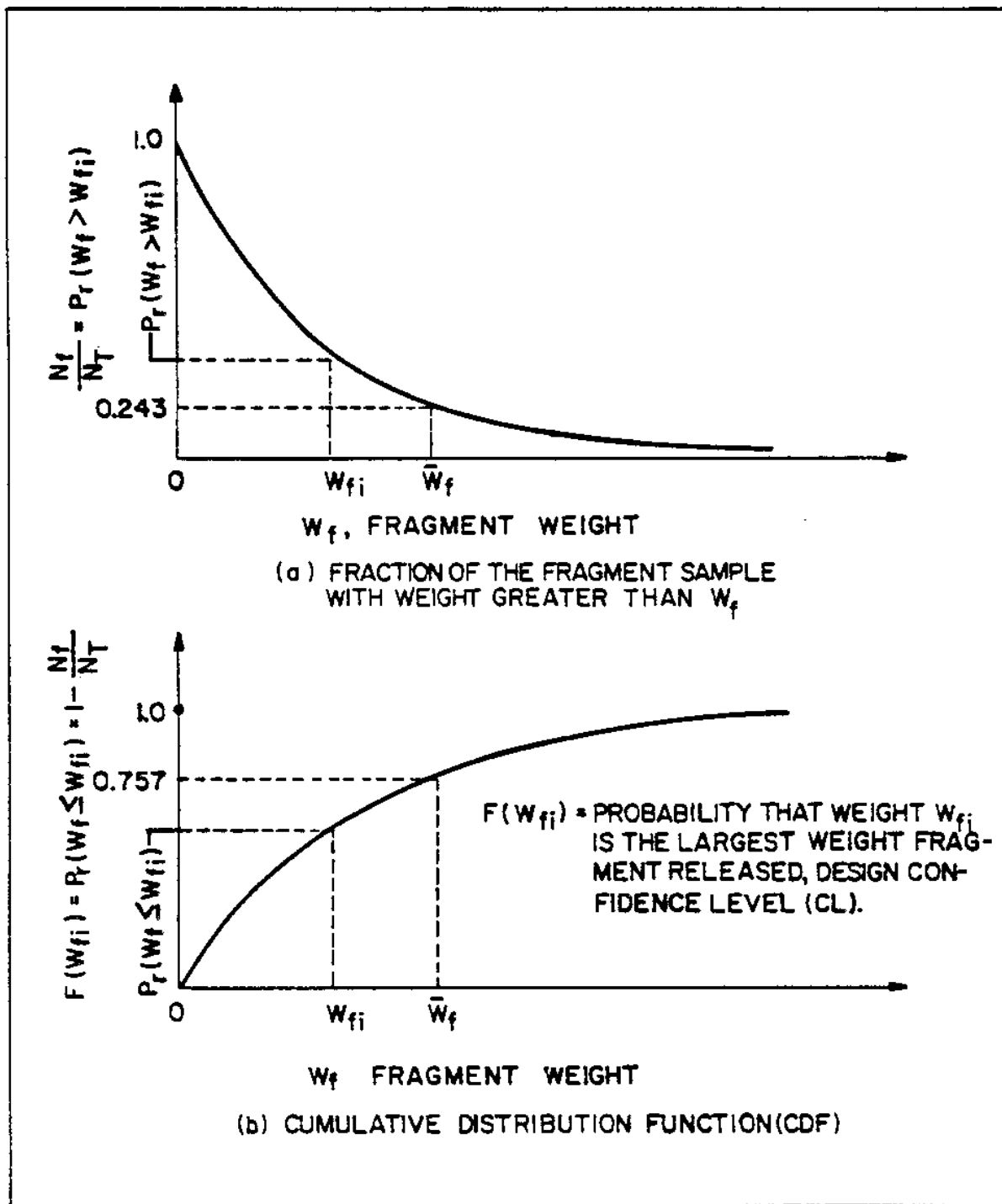

Figure 27
Fragment Weight Distribution Relationships

Then, taking the logarithm and squaring both sides of the equation:

$$\text{EQUATION:} \quad W_F/M_A^2 = \ln^2(1 - CL) \quad (29a)$$

or:

$$\text{EQUATION:} \quad W_F = M_A^2 \ln^2(1 - CL) \quad (29b)$$

(a) Equation (29) can then be used to calculate the design fragment weight for a prescribed probability or design confidence level.

(b) Note that, physically, the maximum possible value of $W_{F\gamma}$ is $W_{C\gamma}$, the total casing weight. For values of CL extremely close to 1, the value of $W_{F\gamma}$ calculated for Equation (29) may exceed $W_{C\gamma}$. In such cases, $W_{F\gamma}$ should be set equal to the casing weight. This inconsistency occurs due to the use of an infinite distribution to describe a phenomenon which obviously has a finite upper limit. The best example of this is obtained by letting CL equal 1.0 in Equation (29). The infinite value obtained for $W_{F\gamma}$ illustrates that the chosen model is not physically reasonable for CL values extremely close to 1.0. By imposing the condition that $W_{F\gamma}$ be equal to $W_{C\gamma}$ for a probability of 1.0, an expression can be derived for a truncated $W_{F\gamma}$ distribution:

$$\text{EQUATION:} \quad W_F = M_A^2 \ln^2 [1 - CL(1 - e^{-W_c^{1/2}/M_A})] \quad (30)$$

(c) Comparison of Equation (30) with Equation (29) for some particular cases shows that the results are virtually identical, except for CL values greater than 0.9999. Hence, the small benefit gained by the use of Equation (30) does not justify its increased complexity and Equation (29) is recommended for use in design.

(d) Finally, an expression can be derived for the probability distribution function of fragment weights $PDF(W_{F\gamma})$, since:

$$\text{EQUATION:} \quad PDF(W_F) = (2 - \bar{W}_F/W_F)^{-1/2} [e^{-(2\bar{W}_F/W_F)^{1/2}}] \quad (31)$$

This exponential distribution is shown schematically in Figure 28.

(e) In order to implement these relationships for practical design, a step-by-step procedure is outlined in this Section. Design charts (Figures 29, 30, 31 and 32) and Table 4 are included to reduce the amount of calculations.

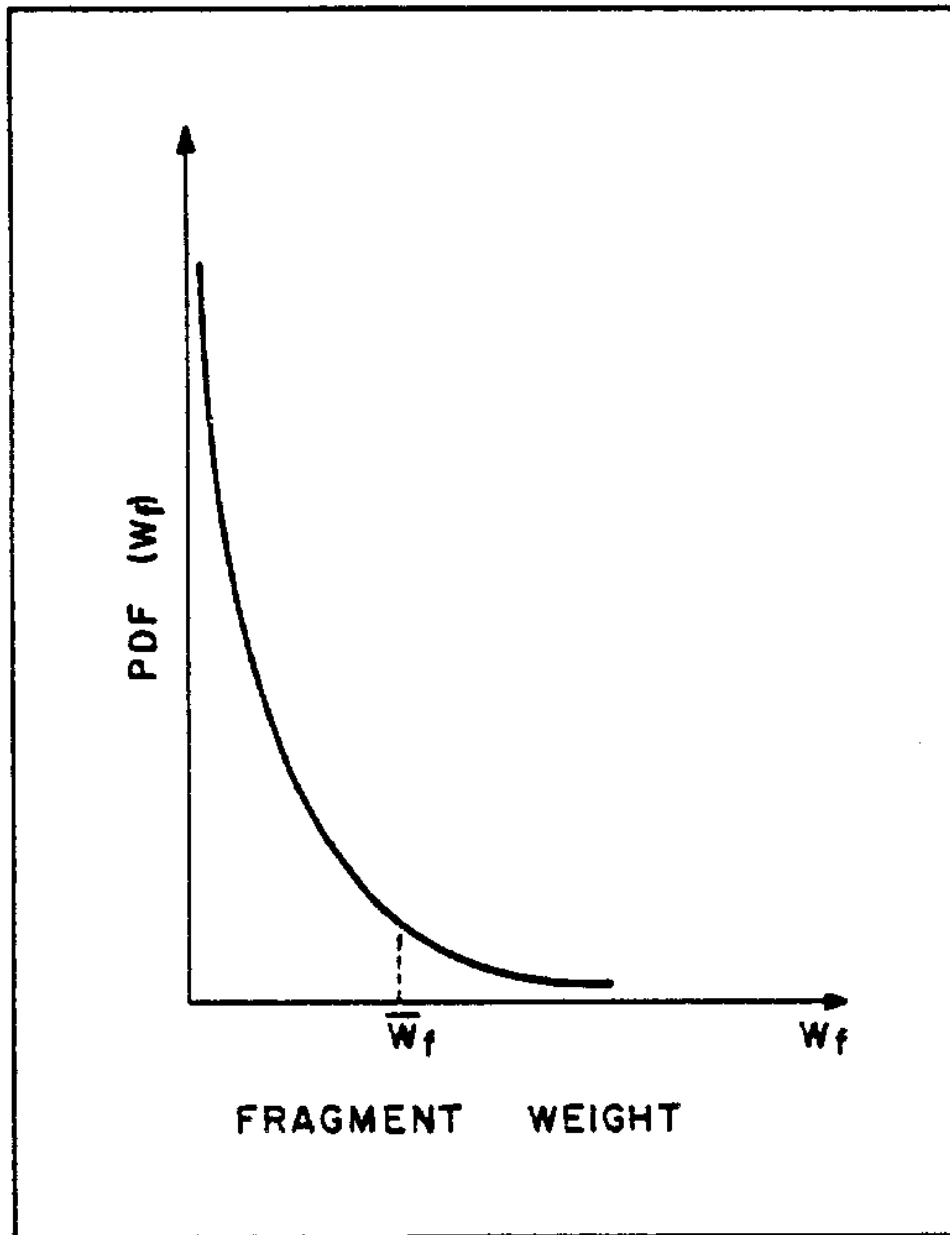

FIGURE 28

Probability Distribution Function of Fragment Weights

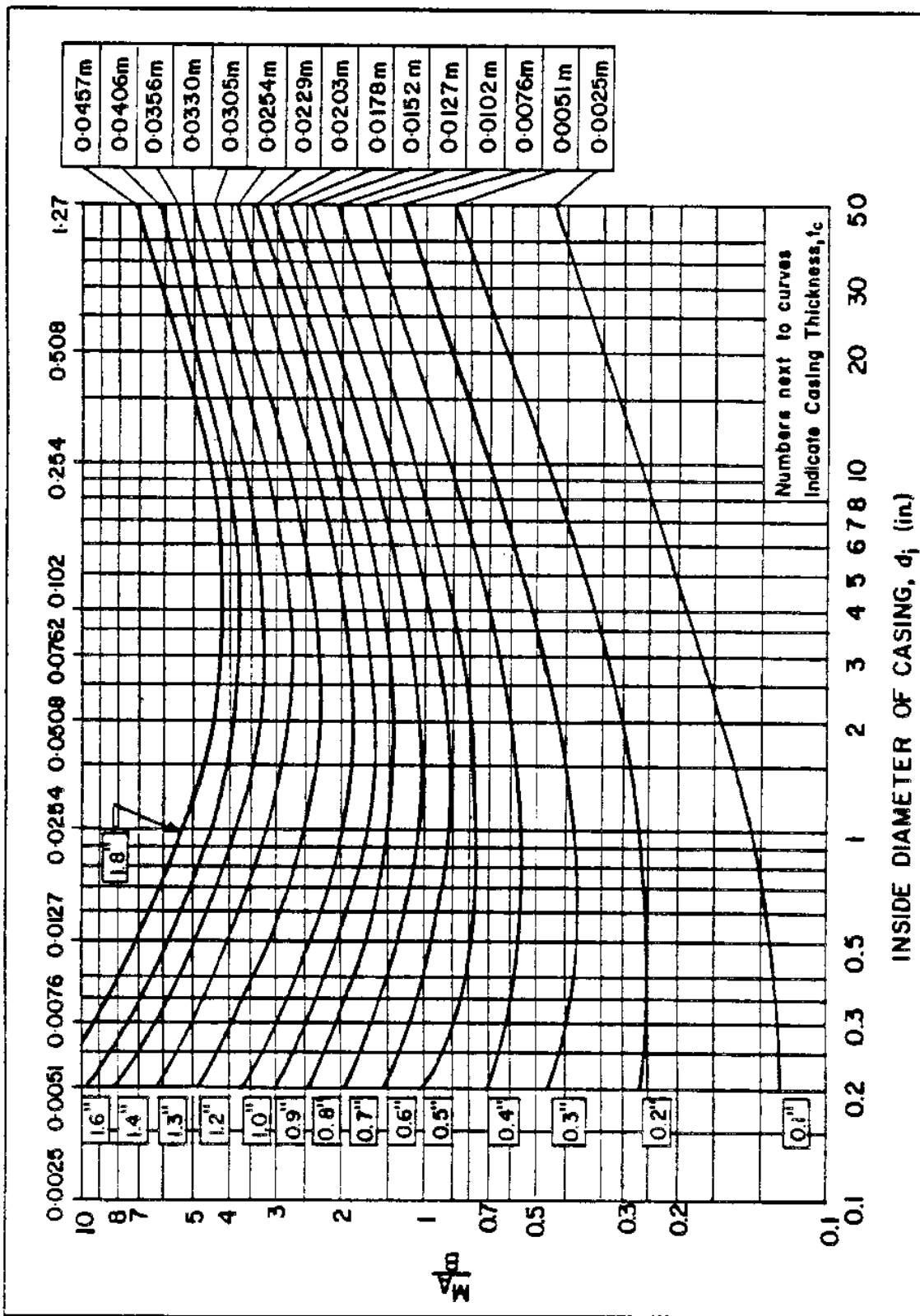

FIGURE 29
 M_A/B vs. Casing Geometry

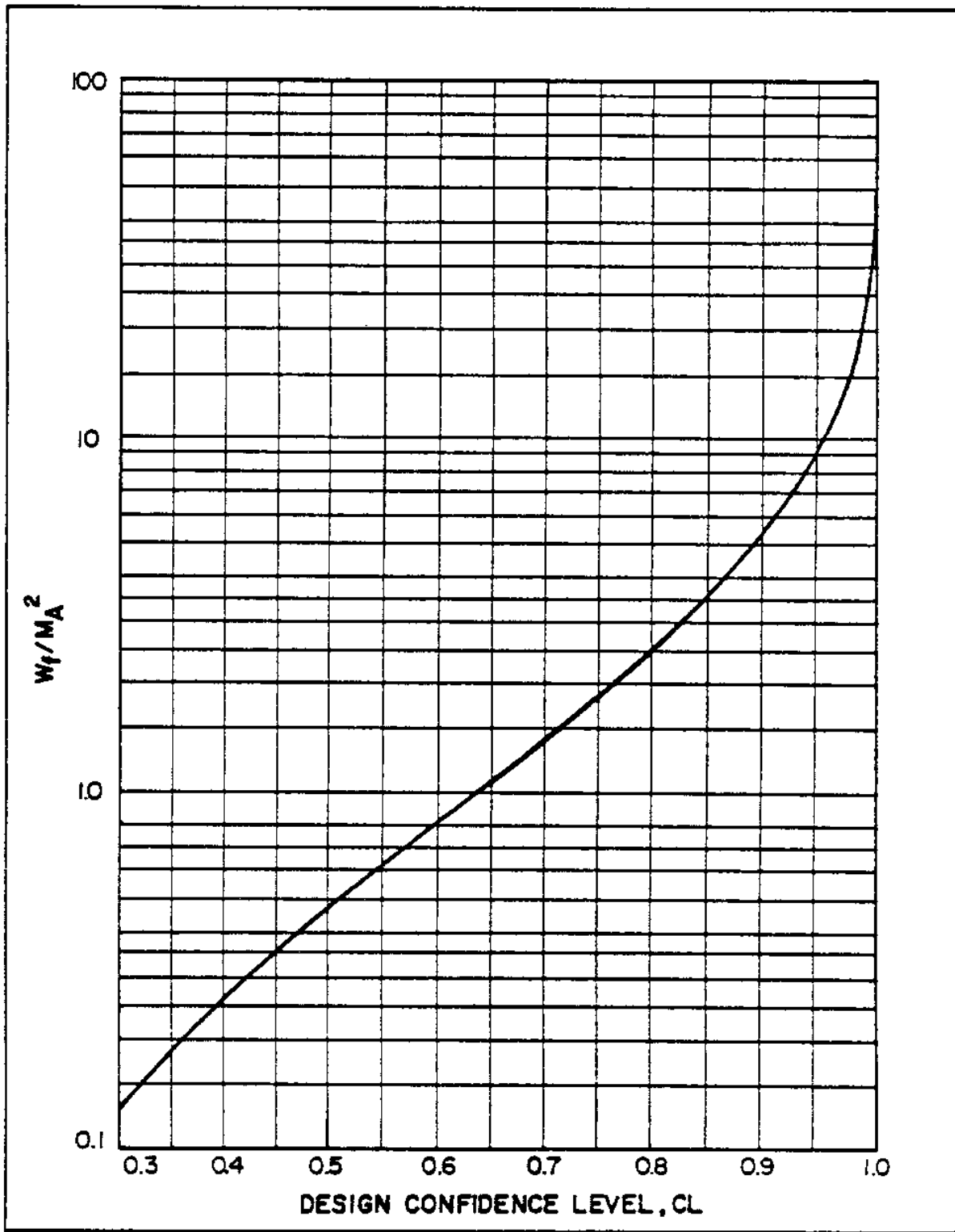

FIGURE 30

Design Fragment Weight vs. Design Confidence Level (0.3 to 1.0)

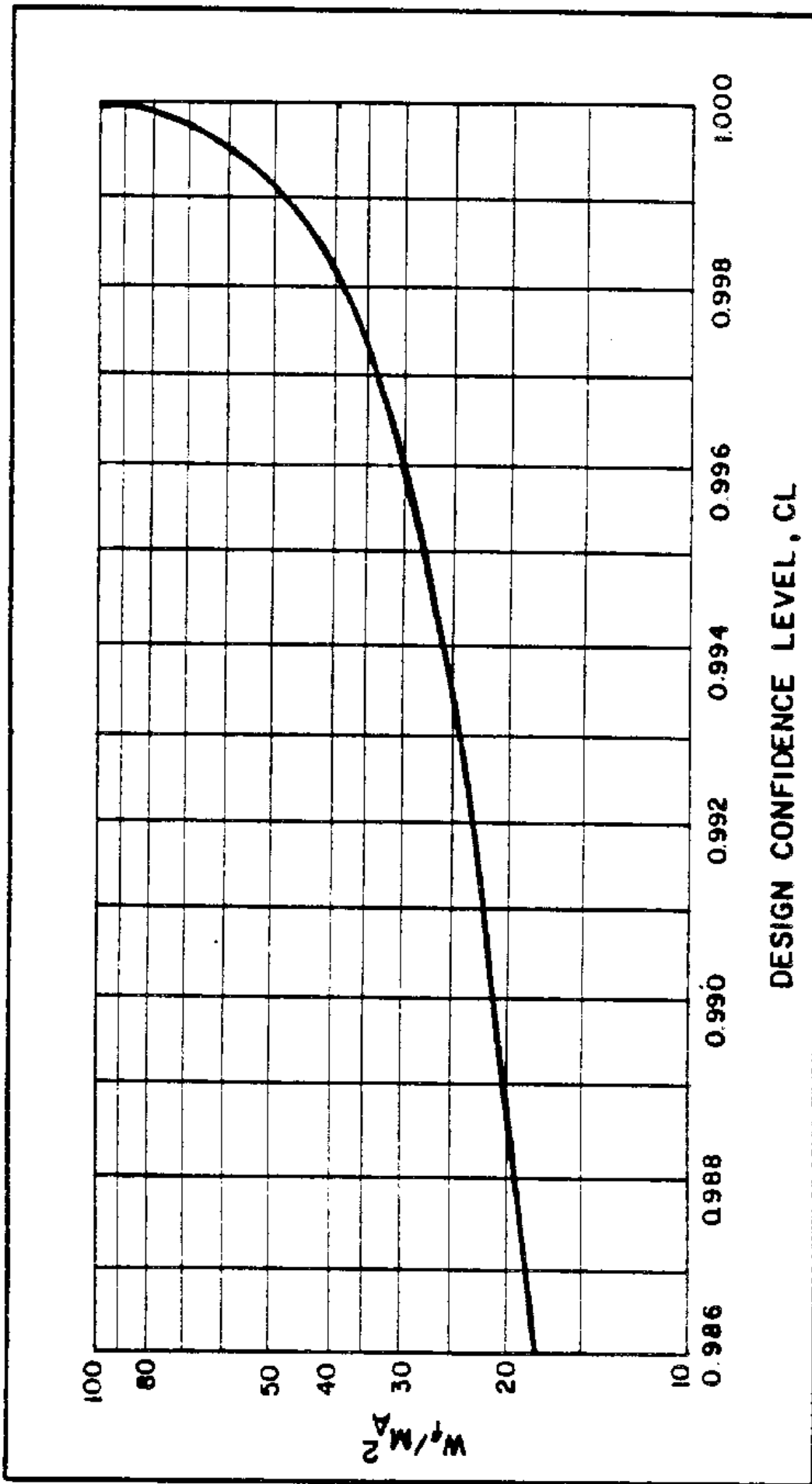

FIGURE 31

Design Fragment Weight vs. Design Confidence Level (0.986 to 1.0)

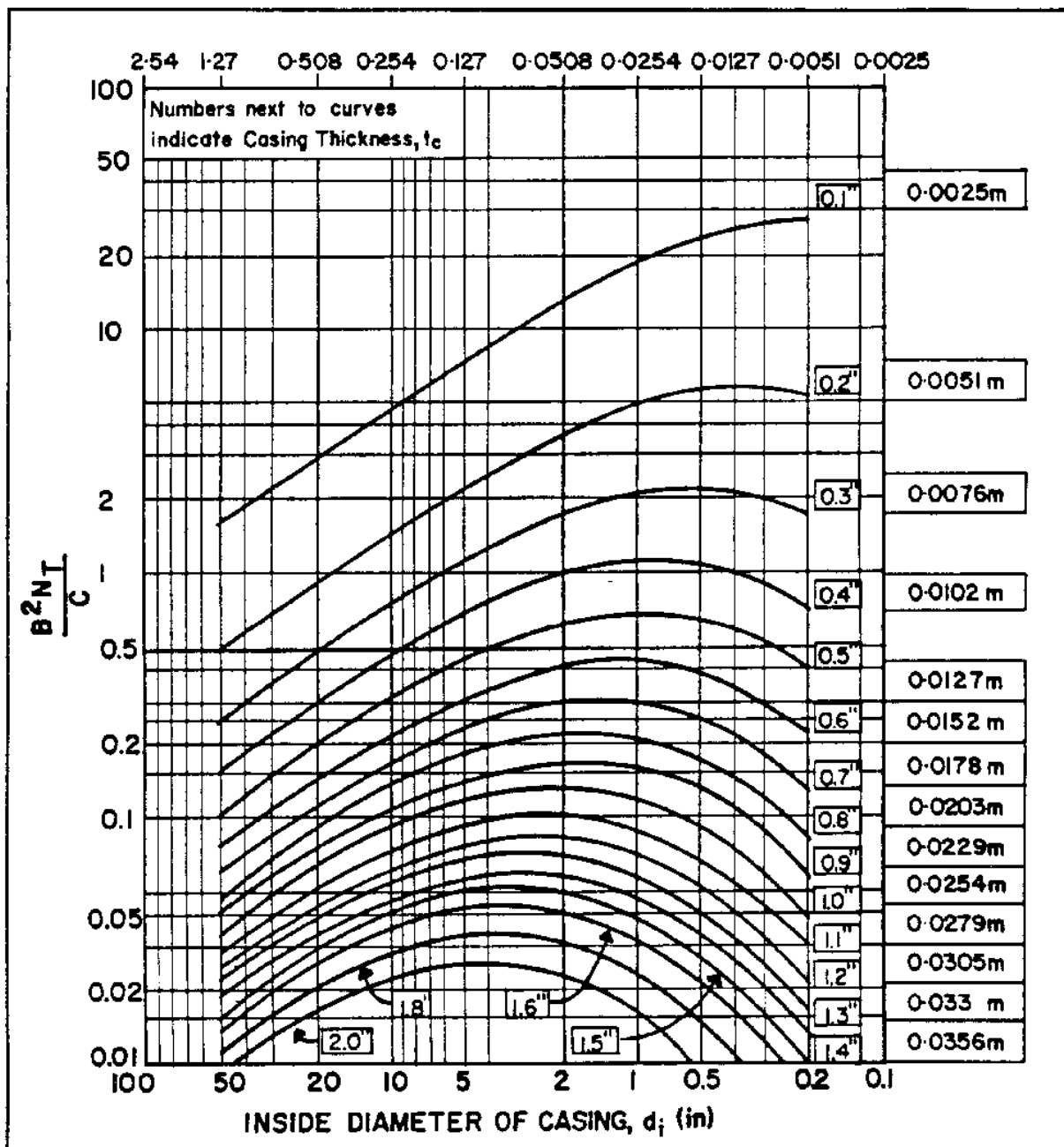

FIGURE 32
 $(B^2 N_T)/C$ vs. Casing Geometry

Table 4
Design Fragment Weights for Various Design Confidence Levels

Design Confidence Level (CL)	$W_{\text{frag}}/M^{2/3}A$	Design Confidence Level (CL)	$W_{\text{frag}}/M^{2/3}A$
0.10	0.01	0.90	5.30
0.20	0.05	0.95	8.97
0.30	0.13	0.98	15.30
0.40	0.26	0.99	21.21
0.50	0.48	0.995	28.07
0.60	0.84	0.999	47.72
0.70	1.45	0.9995	57.77
0.80	2.59	0.9999	84.83

12. EXAMPLE PROBLEMS.

a. Blast Environment Inside Vented Cubicle.

Problem: Consider a 4-wall cubicle with a hole in its roof containing a certain weight of explosive. Determine the pressure-time loading on a given wall.

Given:

- (1) Diameter of hole in roof.
- (2) Charge weight and location.
- (3) Dimensions of cubicle and the wall in question.

Solution:

- (1) Calculate the values of A , W , and V .
- (2) Determine parameters $A/V^{2/3}$, W/V , and $A/W^{2/3}$.
- (3) Find scaled impulse of gas pressure from Figure 10.
- (4) Find peak gas pressure from Figure 8 and calculate fictitious duration of gas pressure.

- (5) Determine impulse of shock loading using one of Figures 4-17 through 4-62 of NAVFAC P-397.
- (6) Determine duration of shock load using Equation (17) and determine fictitious peak shock pressure.

Calculation:

Given:

- (1) Diameter of hole in roof = 5.75 feet.
- (2) Charge weight = 30.8 pounds TNT, located at geometric center of cubicle.
- (3) Cubicle has dimensions of 15 x 10 x 10 feet and the wall in question is 15 x 10 feet.

Solution:

$$(1) A = [\pi]d^2/4 = [\pi] \times 5.75^2/4 = 26.0 \text{ ft}^2$$

$$W = 1.2 \times \text{Charge Weight} = 1.2 \times 30.8 = 37.0 \text{ lb}$$

$$V = L \times W \times H = 15.0 \times 10.0 \times 10.0 = 1,500.0 \text{ ft}^3$$

$$(2) A/V^{2/3} = 26.0/1,500^{2/3} = .20 < .21 \quad \text{O.K.}$$

$$W/V = 37.0/1,500.0 = .025 \text{ lb/ft}^3$$

$$A/W^{2/3} = 26.0/37.0^{2/3} = 2.34 \text{ ft}^2/\text{lb}^{2/3}$$

- (3) Scaled impulse of gas pressure from Figure 10.

$$i_{\text{gas}}/W^{1/3} = 1,190.0 \text{ psi-ms/lb}^{1/3}$$

$$i_{\text{gas}} = 1,190.0 \times 37^{1/3} = 3,965.0 \text{ psi-ms}$$

- (4) Peak gas pressure from Figure 8.

$$P_{\text{gas}} = 210.0 \text{ psi}$$

Fictitious duration is:

$$t_{\text{fict}} = \frac{2i_{\text{gas}}/P_{\text{gas}}}{210.0} = \frac{2 \times 3,965.0}{210.0} = 37.8 \text{ ms}$$

- (5) Scaled shock impulse for 15- by 10-foot wall using Figure 4-62 of NAVFAC P-397 and $L/H = 1.50$, $h/H = .50$, $1/L = .50$, $L/R_A = 3.00$, $Z_A = 1.50$, and $N = 4$.

$$i_{\text{shock}}/W^{1/3} = 250 \text{ psi-ms/lb}^{1/3}$$

$$i_{\text{shock}} = 37^{1/3} \times 250 = 833.0 \text{ psi-ms}$$

- (6) Determine the value of parameters in Equation (17) for duration of shock load from Figure 4-5 of NAVFAC P-397.

$$(t_{rA})_N = .5 \text{ ms}$$

$$(t_{rA})_F = 1.9 \text{ ms}$$

$$(t_{rO})_F = 1.6 \text{ ms}$$

$$\begin{aligned} t_{L'}^J_{rO} &= (t_{rA})_F - (t_{rA})_N + (t_{rO})_F \\ &= 1.9 - .5 + 1.6 = 3.0 \text{ ms} \end{aligned}$$

Fictitious peak shock pressure:

$$P_{r'} = \frac{L_{2i}^J_{rb}}{t_{L'}^J_{rO}} = \frac{2 \times 833.0}{3.0} = 555.3 \text{ psi}$$

b. Blast Environment Outside Cubicle.

Problem: For a given amount of explosives stored in a 3-wall cubicle without a roof, the pressures anywhere behind the backwall and sidewalls should not exceed a certain value. Determine the dimensions of the cubicle and the peak pressures behind the sidewalls and backwall and out the open front at a range of 200 feet.

Given:

- (1) Charge weight, W.
- (2) Maximum peak incident pressure, $(P_{rso})_{max}$.

Solution:

- (1) For the given maximum peak incident pressure, determine the charge-to-volume ratio, W/V, and hence the volume of the cubicle using Figure 14.
- (2) Determine dimensions of cubicle for given volume.
- (3) Determine the scaled distance, $R/W^{1/3}$.
- (4) Using Figure 13, determine the incident pressures behind the backwall, sidewalls, and front wall. Compare results with the maximum peak incident pressure.

Calculation:

Given:

- (1) W = 125 pounds of Composition B explosive.
- (2) $(P_{rso})_{max} = 15 \text{ psi}$.

Solution:

- (1) For $(P_{\text{so}})_{\text{max}} = 15 \text{ psi}$, $W/V = 0.017$ from Figure 14.

$$\text{Therefore, } V = 125/0.017 = 7,350 \text{ ft}^3$$

- (2) For a cube, $L = V^{1/3} = (7,350)^{1/3} = 19.4 \text{ ft}$
Therefore, length, height, and width of cubicle should be 19.4 feet
- (3) For a given distance, R , of 200 feet, the scaled distance $R/W^{1/3} = 200(125)^{1/3} = 40 \text{ ft/lb}^{1/3}$
- (4) From Figure 13, $P_{\text{so}} = 1.0 \text{ psi}$ behind the back wall, 1.5 psi behind the sidewalls and 1.8 psi out the open front. $(P_{\text{so}})_{\text{max}} = 15 \text{ psi}$, which is greater than all the other pressures listed above. Therefore, the pressures are correct.

c. Airblast from Underwater Explosions.

Problem: Determine the overpressure at a position 10 feet above the surface and 60 feet from Surface Zero ($y = 10$ and $R = 60$) produced by 1,000 pounds of TNT detonated 25 feet below the surface.

Given:

- (1) Type and weight of explosive.
(2) Location of explosive.

Solution:

- (1) Calculate the scaled charge depth, $[\lambda]_d$.
- (2) Calculate the scaled horizontal distance, $[\lambda]_R$.
- (3) Calculate the scaled vertical distance, $[\lambda]_y$.
- (4) From the appropriate figure, read off the overpressure. Include accuracy of +/- 30 percent.

Calculation:

Given:

- (1) Charge weight, $W = 1,000 \text{ lb}$ of TNT.
(2) $d = 25 \text{ ft}$, $R = 60 \text{ ft}$, and $y = 10 \text{ ft}$

Solution:

- (1) $[\lambda]_d = d/W^{1/3} = 25/1,000^{1/3} = 2.5 \text{ ft/lb}^{1/3}$
(2) $[\lambda]_R = R/W^{1/3} = 60/1,000^{1/3} = 6 \text{ ft/lb}^{1/3}$

$$(3) \lambda_{\gamma} = y/W^{1/3} = 10/1,000^{1/3} = 1 \text{ ft/lb}^{1/3}$$

(4) For $\lambda_{\gamma} = 1.0$, go to Figure 20.

At $\lambda_{x\gamma} = 6$, $\lambda_{d\gamma} = 2.5$, read an overpressure of 0.5 psi

$$P = 0.5 \text{ psi } \pm 0.15 \text{ psi}$$

d. Primary Fragments from Cased Cylindrical Charges.

Problem: Determine the striking velocity of primary fragments, the weight of the largest fragment corresponding to a prescribed confidence level and the number of fragments having a weight greater than a specified amount.

Given:

- (1) Type and density of explosive
- (2) Type and density of casing material
- (3) Casing thickness, $t_{c\gamma}$
- (4) Inside diameter of casing, $d_{i\gamma}$
- (5) Length of charge
- (6) Design Confidence Level, CL
- (7) Distance traveled by fragment, $R_{f\gamma}$
- (8) Critical fragment weight

Solution:

- (1) Calculate the total weight of the explosive, W , and the total weight of the cylindrical portion of the metal casing, $W_{c\gamma}$. Increase the explosive weight by 20 percent (paragraph 2.b, this section).
- (2) Determine the Gurney constant, $[(2E')^{1/2}]$, for the particular explosive from Table 3. For the case of a cylinder uniformly filled with explosive, calculate the initial velocity, $V_{o\gamma}$, of the primary fragments from Equation (21):

$$V_{o\gamma} = (2E')^{1/2} [(W/W_{c\gamma}) / (1 + 0.5W/W_{c\gamma})]^{1/2}$$

For other container and explosive cross-sections, see Table 2.

- (3) Determine the value of the constant, B , for the explosive from Table 3. With this value and the values of the casing diameter, $t_{c\gamma}$, and the average inside diameter, $d_{i\gamma}$, calculate the fragment distribution parameter, $M_{fA\gamma}$, from Equation (23b):

$$M_A = Bt_c^{5/6} d_i^{1/3} (1 + t_c/d_i)$$

or use Figure 20.

- (4) Calculate the weight of the critical design fragment for the prescribed confidence level from Figure 21 or Equation (29b):

$$W_f = M_A^2 \ln^2(1 - CL)$$

- (5) For the distance traveled by the fragments, R_i , calculate the striking velocity, V_s , of the initial design fragment using Equation (22):

$$V_s = V_o e^{-0.004R_i/W_f^{1/3}}$$

If the distance traveled is less than 20 feet, the striking velocity is taken as equal to the initial velocity for all size fragments.

- (6) Calculate the number of fragments having a weight greater than the critical weight which may cause detonation of an acceptor charge and perforate or cause spalling of a concrete barrier from Equation (23a):

$$\ln N_f = \ln(C \cdot M_A) - W_f^{1/2}/M_A$$

Alternatively, N_f can be determined by using Figures 30 and 31. Determine the total number of particles, N_T , from Figure 31 and the Confidence Level, CL, corresponding to the particular fragment weight, W_f , from Figure 30.

The number of particles with weight greater than the weight W_f can be calculated from:

$$N_f = N_T(1 - CL).$$

Calculation:

Given:

- (1) Type of explosive: TNT with density = 0.0558 lb/in³
- (2) Mild steel casing
- (3) Density of casing: 0.281 lb/in³
- (4) Thickness of casing: $t_c = 0.5$ inch
- (5) Inside diameter of casing: $d_i = 12$ inches
- (6) Length of charge: 40 inches
- (7) Design Confidence Level: CL = 0.999

(8) Distance traveled by fragment, $R_f = 15$ ft

(9) Critical fragment weight: 1.5 oz

Solution:

$$(1) \text{ Weight of explosive} = \pi(121^2)(40)(0.0558)/4 \\ = 252.4 \text{ lbs}$$

$$W = 1.2(252.4) \\ = 302.9 \text{ lbs.}$$

$$W_c = [(13)^2 - (121^2)(40)(0.281)]/4 \\ = 220.7 \text{ lbs.}$$

$$w/w_c = 302.9/220.7 \\ = 1.37$$

(2) For TNT in mild steel casing, from Table 3:

$$(2E')^{1/2} = 6,940.$$

Then using Equation (21):

$$V_o = (2E')^{1/2} [<W/W_c> / (1 + 0.5W/W_c)]^{1/2} \\ = 6,940 [1.37 / (1 + 0.5 \times 1.37)]^{1/2} \\ = 6,258 \text{ fps}$$

(3) For TNT in mild steel casing, from Table 3:

$$B = 0.30.$$

Then using Equation (23b):

$$M_A = B t_c^{5/6} d_i^{1/3} (1 + t_c/d_i) \\ = 0.30(0.5)^{5/6}(12)^{1/3}(1 + 0.5/12) \\ = 0.402$$

or from Figure 20:

$$M_A/B = 1.34$$

$$M_A = 1.34(0.3) = 0.402$$

(4) For design Confidence Level $CL = 0.999$ and Equation (29b)

$$W_f = M_A^2 \ln^2(1 - CL) \\ = (0.402)^2 \ln^2(0.001) \\ = 0.16(47.73) \\ = 7.64 \text{ oz}$$

or from Figure 21:

$$w_f/n_a^2 = 48$$

$$W_f = 7.68 \text{ oz}$$

(5) For R_f less than 20 feet,

$$V_s = V_0 \text{ a } 6,258 \text{ ft/sec.}$$

(6) Using Equation (28) to determine the number of fragments having a weight greater than 1.5 oz:

$$N_f = N_T(1 - CL)$$

From Figure 22, for given casing geometry:

$$(B^2 N_T)/W, = 0.275$$

$$N_T = [0.275(220.7)(16)]/0.09 = 10,790$$

Determine the design Confidence Level corresponding to $W_f = 1.5 \text{ oz.}$

$$\begin{aligned} W_f/M_A^2 &= 1.5/0.16 \\ &= 9.4 \end{aligned}$$

From Figure 21, $CL = 0.955$

$$\begin{aligned} \text{Therefore, } N_f &= 10,790(1 - 0.955) \\ &= 486 \text{ fragments.} \end{aligned}$$

13. NOTATION.

- A - Presented area of fragment, in²
Vent area, ft²
- B - Explosive constant
- C_D** - Drag coefficient
- CL - Confidence level
- C' - Fragment distribution constant
- d - Charge depth, ft
Diameter of hole in roof, ft
- d_i - Average inside diameter of casing, in
- (2E')^{1/2} - Gurney's energy constant
- F - Factor to account for effect of casing on effective charge weight
- H - Height, ft

$i_{\Gamma S\gamma}$	-	Specific impulse, psi-ms
$i_{\Gamma G\gamma}$	-	Impulse of gas pressure, psi-ms
$k, k^L \text{ --J}$	-	Factor to determine form of positive and negative, respectively, p-T curve
$k_{\Gamma V\gamma}$	-	Velocity decay coefficient
L	-	Length, ft
$M_{\Gamma A\gamma}$	-	Fragment distribution parameter
$N_{\Gamma f\gamma}$	-	Number of fragments with weight greater than the critical weight
$N_{\Gamma T\gamma}$	-	Total number of fragments
$P_{\Gamma mO\gamma}$	-	Maximum mean pressure, psi
$P_{\Gamma r\gamma}$	-	Peak reflected pressure, psi
$P_{\Gamma S\gamma}$	-	Pressure at time t_s , psi
$P_{\Gamma so\gamma}$	-	Peak positive incident pressure, psi
$P^L \text{ --J }_{\Gamma so\gamma}$	-	Peak negative incident pressure, psi
$(P_{\Gamma so\gamma})_{\Gamma max\gamma}$	-	Peak pressure, psi
PDF	-	Probability distribution function
$q_{\Gamma O\gamma}$	-	Peak dynamic pressure, psi
R	-	Horizontal distance, ft
$R_{\Gamma f\gamma}$	-	Distance from detonation to the protective structure, ft
$R_{\Gamma F\gamma}$	-	Distance to the point on the wall farthest from the charge
$R_{\Gamma N\gamma}$	-	Distance to the point on the wall nearest to the charge
$(t_{\Gamma A\gamma})_{\Gamma F\gamma}$	-	Arrival time blast wave at a point on the wall farthest from the charge, ms
$(t_{\Gamma A\gamma})_{\Gamma N\gamma}$	-	Time of arrival of blast wave at the point on the wall nearest to the charge, ms
$t_{\Gamma C\gamma}$	-	Average casing thickness, in
$t_{\Gamma G\gamma}$	-	Duration of gas pulse, ms
$t'_{\Gamma G\gamma}$	-	Fictitious gas pressure duration, ms

t_{p0}	- Positive phase duration, ms - Duration of shock pulse, ms
t_{-p0}	- Negative phase duration, ms
$(t_{p0})_F$	- Duration of blast pressure at a point on the wall farthest from the charge, ms
t'_{p0}	- Design duration of positive pressure, ms
t_{ps}	- Positive phase time of interest, ms
t_{-ps}	- Negative phase time to interest, ms
T_{pN}	- Natural period of vibration, ms
U	- Transmission velocity, ft/ms
V	- Volume of cubicle, ft^3
V_{p0}	- Initial fragment velocity, fps
V_{ps}	- Fragment velocity at some distance from explosion, fps
W	- Charge weight, lb or oz
W_{pc}	- Casing weight, lb or oz
W_{eff}	- Effective charge weight, lb
W_{pf}	- Fragment weight, oz
\bar{W}_{pf}	- Average particle weight
y	- Vertical distance, ft
Z	- Scaled distance, $\text{ft}/\text{lb}^{1/3}$
$[\alpha]$	- Constant which determines the form of the p-T curve
$[\rho]_a$	- Density of air, oz/in^3
$[\lambda]_d$	- Scaled charge depth, $\text{ft}/\text{lb}^{1/3}$
$[\lambda]_x$	- Scaled horizontal distance, $\text{ft}/\text{lb}^{1/3}$
$[\lambda]_y$	- Scaled vertical distance, $\text{ft}/\text{lb}^{1/3}$

SECTION 3. BEAMS AND COLUMNS IN REINFORCED CONCRETE STRUCTURES

1. INTRODUCTION.

a. Blast resistant concrete buildings subjected to external blast pressures are generally shear wall structures rather than rigid frame structures. Shear wall structures respond to lateral loads in a somewhat different manner than rigid frame structures; the basic difference being the manner in which the lateral loads are transferred to the foundation. In rigid frame structures the lateral loads are transmitted to the foundation through bending of the columns. In shear wall structures, the lateral forces are transmitted to the foundation through both bending and shearing action of the shear walls. Shear walls are inherently strong and will resist large lateral forces. Consequently, shear wall structures are inherently capable of resisting blast loads and can be designed to resist substantially large blast loads whereas rigid frame structures cannot be economically designed to resist significant blast loads.

b. In shear wall structures, beams and columns are usually provided between shear walls to carry the vertical loads including blast loads on the roof and not to transmit lateral loads to the foundation. For example, blast loads applied to the front wall of a two-story shear wall structure are transmitted through the roof and intermediate floor slabs to the shear walls (perpendicular walls) and thus to the foundation. The front wall spans vertically between the foundation, the floor, and the roof slab. The upper floor and roof slabs act as deep beams, and, in turn, transmit the front wall reactions to the shear walls. The roof and floor beams are not subjected to significant axial loads due to the diaphragm action of the slabs. The interior columns are usually not subjected to significant bending moments since there is no sidesway due to the extreme stiffness of the shear walls. However, significant moments can result from unsymmetrical loading conditions. Columns which are monolithic with the exterior walls may be required for severe load conditions. These exterior columns are subjected to both significant axial load and moment. The axial load results from the direct transfer of the roof and floor beam reactions while the moments are caused by the lateral blast load acting on the exterior wall.

c. The design of slab elements has been extensively discussed in NAVFAC P-397. This chapter is concerned solely with the design of beams and columns in a receiver structure subjected to low and intermediate blast pressures resulting from an explosion in a donor structure.

2. DYNAMIC STRENGTH OF MATERIALS.

a. Introduction.

(1) A structural element subjected to a blast loading exhibits a higher strength than a similar element subjected to a static loading. This increase in strength for both concrete and reinforcement is attributed to the rapid rates of strain that occur in dynamically loaded members. These increased stresses or dynamic strengths are used to calculate the element's

dynamic resistance to the applied blast load. Thus, the dynamic ultimate resistance of a member subjected to a blast load is greater than its static ultimate resistance.

(2) Both the concrete and reinforcing steel exhibit greater strength under rapid strain rates. The higher the strain rates, the higher the compressive strength of concrete and the higher the yield and ultimate strength of the reinforcement. This phenomenon is accounted for in the design of a blast resistant structure by using the dynamic stresses to calculate the ultimate resistance of the reinforced concrete members.

b. Static Design Stresses.

(1) The materials of construction to be used for blast resistant structures are given in NAVFAC P-397. The selection of the materials is based primarily on the slab elements since, depending upon the anticipated building usage, these elements may be permitted to attain large deformations. Beams and columns are primary members and, as such, are not permitted to attain large deformations.

(2) Reinforcing steel, designated by the American Society for Testing and Materials (ASTM) as A615, grade 60, is recommended for use in blast resistant structures. Since both beams and columns are not permitted to attain large deflections, the reinforcement is stressed within its yield range. The reinforcement is not stressed into its strain hardening region. Consequently, for the design of beams and columns, the static design stress for the reinforcement is equal to its yield stress ($f_{ry} = 60,000$ psi).

(3) It is recommended that the minimum compressive strength of concrete f'_{rc} be equal to at least 3,000 psi for members with small rotations and 4,000 psi for members with large support rotations. This provision applies primarily for slabs (exterior walls and roof), since beams and columns are not permitted to attain large deformations. Consequently, the concrete strength usually depends upon the design of the slab elements which comprise the vast majority of the structure. The preferred concrete strength for all blast resistant construction is equal to 4,000 psi.

c. Dynamic Design Stresses.

(1) The increased strength of materials due to strain rate is described by the dynamic increase factor, DIF. The DIF is equal to the ratio of the dynamic to static stress, e.g., f_{rdy}/f_{ry} and f'_{rdc}/f'_{rc} . The DIF depends on the material and the applied strain rate. For the design of beams and columns subjected to low and intermediate blast pressures, a DIF equal to 1.10 is used for reinforcement in bending and a DIF equal to 1.25 is used for concrete in compression. It is recommended that no DIF be considered when determining shear or bond capacities nor when calculating quantities of shear reinforcement.

(2) The dynamic design stress is obtained by multiplying the appropriate static design stress by the appropriate DIF, where:

$$\text{EQUATION:} \quad f_{rdy} = (\text{DIF}) f_{ry} \quad (32)$$

$$\text{EQUATION:} \quad f'_{rc} = (\text{DIF}) f'_{c} \quad (33)$$

For the recommended reinforcing steel having a static yield stress $f_{y} = 60,000$ psi, the dynamic design stress $f_{dy} = 66,000$ psi. While for the recommended concrete compression strength $f'_{c} = 4,000$ psi, the dynamic design stress $f'_{dc} = 5,000$ psi.

3. DYNAMIC DESIGN OF BEAMS.

a. General.

(1) The design of beams is performed in a manner similar to that given in NAVFAC P-397 for slabs. The most significant and yet not very important difference in the design procedure is that in the case of a slab, the calculations are based on a unit area, whereas for a beam, they are based on a unit length of the beam.

(2) Beams are primary support members and as such are generally not permitted to attain large plastic deformations. In fact, the ultimate support rotation of beams is limited to 2 degrees. Consequently, the maximum stress developed by the reinforcement will be within its yield range. The reinforcement is not stressed into its strain hardening region.

b. Ultimate Dynamic Moment Capacity.

(1) The ultimate dynamic resisting moment, M_{u} , of a rectangular beam section of width, b , with tension reinforcement only is given by:

$$\text{EQUATIONS:} \quad M_{u} = A_{s} f_{dy} (d - a/2) \quad (34)$$

and

$$a = \frac{A_{s} f_{dy}}{0.85b f'_{dc}} \quad (35)$$

where,

- M_{u} = ultimate moment capacity, in-lb
- A_{s} = total area of tension reinforcement within the beam, in²
- f_{dy} = dynamic yield stress of reinforcement, psi
- d = distance from extreme compression fiber to centroid of tension reinforcement, in
- a = depth of equivalent rectangular stress block, in
- b = width of beam, in
- f'_{dc} = dynamic ultimate compressive strength of concrete, psi

The reinforcement ratio, p , is defined as:

$$\text{EQUATION:} \quad p = \frac{A_{s}}{bd} \quad (36)$$

To insure against sudden compression failures, the reinforcement ratio, p , must not exceed 0.75 of the ratio p_{rb} which produces balanced conditions at ultimate strength and is given by:

$$\text{EQUATION: } p_{rb} = \frac{0.85K_{r1} f'_{rc}}{f_{ry}} \frac{87,000}{87,000 + f_{ry}} \quad (37)$$

where,

$K_{r1} = 0.85$ for f'_{rc} up to 4,000 psi and is reduced by 0.05 for each 1,000 psi in excess of 4,000 psi.

(2) The ultimate dynamic resisting moment, M_{ru} , of a rectangular beam section of width, b , with compression reinforcement is given by:

$$\text{EQUATION: } M_{ru} = (A_{rs} - A'_{rs})f_{ry}(d - a/2) + A'_{rs} f_{ry}(d-d') \quad (38)$$

and

$$\text{EQUATION: } a = \frac{(A_{rs} - A'_{rs}) f_{ry}}{0.85b f'_{rc}} \quad (39)$$

where,

A'_{rs} = total area of compression reinforcement within the beam, in²

d' = distance from extreme compression fiber to centroid of compression reinforcement, in

The compression reinforcement ratio p' is defined as:

$$\text{EQUATION: } p' = \frac{A'_{rs}}{bd} \quad (40)$$

Equation (38) is valid only when the compression reinforcement yields at ultimate strength. This condition is satisfied when:

$$\text{EQUATION: } p-p' < \neq 0.85 K_{r1} \frac{f'_{rc} d'}{f_{ry} d} \frac{87,000}{87,000 - f_{ry}} \quad (41)$$

In addition, the quantity $p-p'$ must not exceed 0.75 of the value of p_{rb} given in Equation (37) in order to insure against sudden compression failures. If $p-p'$ is less than the value given by Equation (41), the ultimate resisting moment should not exceed the value given by Equation (34).

(3) For the design of concrete beams subjected to exterior blast loads, it is recommended that the ultimate resisting moment be computed using Equation (34) even though a considerable amount of compression reinforcement is required to resist rebound loads. It should be noted that a large amount of compression steel that does not yield due to the linear strain variation across the depth of the section, has a negligible effect on the total capacity.

c. Minimum Flexural Reinforcement.

(1) To insure proper structural behavior under both conventional and blast loadings, a minimum amount of flexural reinforcement is required. The minimum reinforcement required for beams is somewhat greater than that required for slabs since an overload load in a slab would be distributed laterally and a sudden failure will be less likely. The minimum required quantity of reinforcement is given by:

$$\text{EQUATION:} \quad p = 200/f_y \quad (42)$$

which, for 60,000 psi yield strength steel, is equal to a reinforcement ratio of 0.0033. This minimum reinforcement ratio applies to the tension steel at mid-span of simply supported beams and to the tension steel at the supports and mid-span of fixed-end beams.

(2) Concrete beams with tension reinforcement only are not permitted. Compression reinforcement, at least equal to one-third the required tension reinforcement, must be provided. This reinforcement is required to resist the ever present rebound forces. Depending upon the magnitude of these rebound forces, the required compression reinforcement may equal the tension reinforcement.

d. Diagonal Tension.

(1) The nominal shear stress, v_n , as a measure of diagonal tension is computed from:

$$\text{EQUATION:} \quad v_n = \frac{V_n}{bd} \quad (43)$$

where,

v_n = nominal shear stress, psi

V_n = total shear at critical section, lb

The critical section is taken at a distance, d , from the face of the support for those members that cause compression in their supports. The shear at sections between the face of the support and the section d therefrom need not be considered critical. For those members that cause tension in their supports, the critical section is at the face of the supports.

(2) The shear stress permitted on an unreinforced web of a beam subjected to flexure only is limited to:

$$\text{EQUATION: } v_{rc} = [\phi] [1.9 (f'_{rc})^{1/2} + 2500 p] \leq 2.28 [\phi] (f'_{rc})^{1/2} \quad (44)$$

where,

v_{rc} = maximum shear capacity of an unreinforced web, psi
 p = reinforcement ratio of the tension reinforcement at the support

$[\phi]$ = capacity reduction factor equal to 0.85

(3) whenever the nominal shear stress, v_{ru} , exceeds the shear capacity, v_{rc} , of the concrete, shear reinforcement must be provided to carry the excess. Closed ties placed perpendicular to the flexural reinforcement must be used to furnish the additional shear capacity. Open stirrups, either single or double leg, are not permitted. The required area of shear reinforcement is calculated using:

$$\text{EQUATION: } A_{rv} = [(v_{ru} - v_{rc}) b s_{rs}] / [\phi] f_{ry} \quad (45)$$

where,

A_{rv} = total area of stirrups, sq in

$v_{ru} - v_{rc}$ = excess shear stress, psi

s_{rs} = spacing of stirrups in the direction parallel to the longitudinal reinforcement, in

$[\phi]$ = capacity reduction factor equal to 0.85

(4) In order to insure the full development of the flexural reinforcement in a beam, a premature shear failure must be prevented. The following limitations must be considered in the design of the closed ties: a) the design shear stress (excess shear stress $v_{ru} - v_{rc}$) used in Equation (45) shall be equal to, or greater than, the shear capacity of unreinforced concrete, v_{rc} , as obtained from Equation (44); b) the nominal shear stress, v_{ru} , must not exceed $10 [\phi] (f'_{rc})^{1/2}$; c) the area, A_{rv} , of closed ties should not be less than $0.0015 b s_{rs}$; d) the required area, A_{rv} , of closed ties shall be determined at the critical section, and this quantity of reinforcement shall be uniformly distributed throughout the member; and e) the maximum spacing of closed ties is limited to $d/2$ when $v_{ru} - v_{rc}$ is less than $4 [\phi] (f'_{rc})^{1/2}$ but is further limited to $d/4$ when $v_{ru} - v_{rc}$ is greater than $4 [\phi] (f'_{rc})^{1/2}$.

e. Direct Shear.

(1) Direct shear failure of a member is characterized by the rapid propagation of a vertical crack through the depth of the member. This crack is usually located at the supports where the maximum shear stresses occur. Failure of this type is possible even in members reinforced for diagonal tension.

(2) The concrete between the flexural reinforcement is capable of resisting direct shear stress. The concrete remains effective because these elements are subjected to comparatively low blast loads and are designed to attain small support rotations. The magnitude of the ultimate direct shear force, V_{rd} which can be resisted by a beam is limited to:

$$\text{EQUATION:} \quad V_{rd} = 0.18 f'_{cd} b d \quad (46)$$

The total support shear produced by the applied loading may not exceed V_{rd} . Should the support shear exceed V_{rd} , the depth or width of the beam or both must be increased since the use of diagonal bars is not recommended. Unlike slabs which require minimum diagonal bars, beams do not require these bars since the quantity of flexural reinforcement in beams is much greater than for slabs.

f. Torsion.

(1) In addition to the flexural effects considered above, concrete beams may be subjected to torsional moments. Torsion rarely occurs alone in reinforced concrete beams. It is present more often in combination with transverse shear and bending. Torsion may be a primary influence but more frequently it is a secondary effect. If neglected, torsional stresses can cause distress or failure.

(2) Torsion is encountered in beams that are unsymmetrically loaded. Beams are subject to twist if the slabs on each side are not the same span or if they have different loads. Severe torsion will result on beams that are essentially loaded from one side. This condition exists for beams around an opening in a roof slab and for pilasters around a door opening.

(3) The design for torsion presented in this section is limited to rectangular sections. For a beam-slab system subjected to conventional loading conditions, a portion of the slab will assist the beam in resisting torsional moments. However, in blast resistant design, a plastic hinge is usually formed in the slab at the beam and, consequently, the slab is not effective in resisting torsional moments.

(4) The nominal torsional stress in a rectangular beam in the vertical direction (along h) is given by:

$$\text{EQUATION:} \quad \tau_{Vd} = \frac{3 T_{rd}}{[\phi] b^2 h} \quad (47a)$$

and the nominal torsional stress in the horizontal direction (along b) is given by:

$$\text{EQUATION:} \quad \tau_{Hd} = \frac{3 T_{rd}}{[\phi] b h^2} \quad (47b)$$

where,

$v_{\Gamma t u_{\Gamma}}$ = nominal torsional stress, psi
 $T_{\Gamma u_{\Gamma}}$ = total torsional moment at critical section, in-lb
 $[\phi]$ = capacity reduction factor equal to 0.85
 b = width of beam, in
 h = overall depth of beam, in

The critical section for torsion is taken at the same location as diagonal tension. It should be noted that the torsion stress in the vertical face of the beam (along h) is maximum when b is less than h , whereas the torsion stress along the horizontal face of the beam (along b) is maximum when b is greater than h .

(5) For a beam subjected to combined shear (diagonal tension) and torsion, the shear stress and the torsion stress permitted on an unreinforced section are reduced by the presence of the other. The shear stress permitted on an unreinforced web is limited to:

$$\text{EQUATION:} \quad v_{\Gamma c_{\Gamma}} = \frac{2[\phi] (f'_{\Gamma c_{\Gamma}})^{L_{1/2}}}{[1 + (v_{\Gamma t u_{\Gamma}} / 1.2 v_{\Gamma u_{\Gamma}})^{L_2}]^{L_{1/2}}} \quad (48)$$

while the torsion stress taken by the concrete of the same section is limited to:

$$\text{EQUATION:} \quad v_{\Gamma t c_{\Gamma}} = \frac{2.4 [\phi] (f'_{\Gamma c_{\Gamma}})^{L_{1/2}}}{[1 + (1.2 v_{\Gamma u_{\Gamma}} / v_{\Gamma t u_{\Gamma}})^{L_2}]^{L_{1/2}}} \quad (49)$$

where,

$v_{\Gamma c_{\Gamma}}$ = maximum shear capacity of an unreinforced web, psi
 $v_{\Gamma t c_{\Gamma}}$ = maximum torsion capacity of an unreinforced web, psi
 $[\phi]$ = capacity reduction factor equal to 0.85
 $v_{\Gamma u_{\Gamma}}$ = nominal shear stress, psi
 $v_{\Gamma t u_{\Gamma}}$ = nominal torsion stress in the direction of $v_{\Gamma u_{\Gamma}}$, psi

It should be noted that the shear stress permitted on an unreinforced web of a beam subjected to shear only is given by Equation (44). Whereas, the torsion stress permitted on an unreinforced web of a beam subjected to torsion only is given by:

$$\text{EQUATION:} \quad v_{\Gamma t c_{\Gamma}} = 2.4 [\phi] (f'_{\Gamma c_{\Gamma}})^{L_{1/2}} \quad (50)$$

(6) whenever the nominal shear stress, $v_{\tau u}$, exceeds the shear capacity, $v_{\tau c}$, of the concrete, shear reinforcement must be provided to carry the excess. This quantity of shear reinforcement is calculated using Equation (45) except the value of $v_{\tau c}$ shall be obtained from Equation (48) which includes the effects of torsion.

(7) whenever the nominal torsion stress, $v_{\tau t}$, exceeds the maximum torsion capacity of the concrete, torsion reinforcement in the shape of closed ties, shall be provided to carry the excess. The required area of the vertical leg of the closed ties is given by:

$$\text{EQUATION: } A_{\tau}(t)_{\tau V} = \frac{[v_{\tau}(t)_{\tau V} - v_{\tau c}] b^2 J_s}{3[\phi][\alpha]_{\tau} b_{\tau} h_{\tau} f_{\tau Y}} \quad (51)$$

and the required area of the horizontal leg of the closed ties is given by:

$$\text{EQUATION: } A_{\tau}(t)_{\tau H} = \frac{(v_{\tau}(t)_{\tau H} - v_{\tau c}) b h^2 J_s}{3[\phi][\alpha]_{\tau} b_{\tau} h_{\tau} f_{\tau Y}} \quad (52)$$

where,

- A_{τ} = area of one leg of a closed stirrup resisting torsion within a distance s , sq in
- s = spacing of torsion reinforcement in a direction parallel to the longitudinal reinforcement, in
- $[\phi]$ = capacity reduction factor equal to 0.85
- b_{τ} = center-to-center dimension of a closed rectangular tie along b , in
- h_{τ} = center-to-center dimension of a closed rectangular tie along h , in
- $[\alpha]_{\tau} = 0.66 + 0.33 (h_{\tau}/b_{\tau}) < / = 1.50$ for $h_{\tau} > / = b_{\tau}$
- $[\alpha]_{\tau} = 0.66 + 0.33 (b_{\tau}/h_{\tau}) < / = 1.50$ for $h_{\tau} < / = b_{\tau}$

The size of the closed tie provided to resist torsion must be the greater of that required for the vertical (along h) and horizontal (along b) directions. For the case of b less than h , the torsion stress in the vertical direction is maximum and the horizontal direction need not be considered. However, for b greater than h , the torsion stress in the horizontal direction is maximum. In this case, the required A_{τ} for the vertical and horizontal directions must be obtained and the greater value used to select the closed stirrup. It should be noted that in the horizontal direction, the beam is not subjected to lateral shear (slab resists lateral loads) and the value of $v_{\tau c}$ used in Equation (52) is calculated from Equation (50) which does not include the effect of shear.

(8) When torsion reinforcement is required, it must be provided in addition to reinforcement required to resist shear. The closed ties required for torsion may be combined with those required for shear. However, the area furnished must be the sum of the individually required areas and the most restrictive requirements for spacing and placement must be met. Figure 33a shows several ways to arrange web reinforcement. For low torsion and shear, it is convenient to combine shear and torsional web reinforcement in the form of a single closed stirrup whose area is equal to $A_{\tau t} + A_{\tau v}/2$. For high torsion and shear, it would be economical to provide torsional and shear reinforcement separately. Torsional web reinforcement consists of closed stirrups along the periphery, while the shear web reinforcement is in the form of closed stirrups distributed along the width of the member. For very high torsion, two closed stirrups along the periphery may be used. The combined area of the stirrups must equal $A_{\tau t}$ and they must be located as close as possible to each other, i.e., the minimum separation of the flexural reinforcement. In computing the required area of stirrups using Equation (51), the value of $b_{\tau t}$ should be equal to the average center-to-center dimension of the closed stirrups as shown in Figure 33a.

(9) In the design of closed ties for beams subjected to both shear and torsion, the following limitations must be considered: a) the minimum quantity of closed ties provided in a beam subjected to both shear and torsion shall not be less than that required for a beam subjected to shear alone; b) the maximum nominal shear stress, $v_{\tau u}$, must not exceed $10 [\phi] (f'_{rc})^{1/2}$; c) the maximum nominal torsional stress, $\max v_{\tau t u}$, shall not exceed the following;

$$\text{EQUATION:} \quad \max v_{\tau t u} < / = \frac{12 [\phi] (f'_{rc})^{1/2}}{[1 + (1.2v_{\tau u}/v_{\tau t u})^{1/2}]^{1/2}} \quad (53)$$

d) the required spacing of closed stirrups shall not exceed $(b_{\tau t} + h_{\tau t})/4$, or 12 inches nor the maximum spacing required for closed ties in beams subjected to shear only; e) the required areas $A_{\tau v}$ and $A_{\tau t}$ shall be determined at the critical section and this quantity of reinforcement shall be uniformly distributed throughout the member; and f) to insure the full development of the ties, they shall be closed using 135-degree hooks.

(10) In addition to closed stirrups, longitudinal reinforcement must be provided to resist the longitudinal tension caused by the torsion. The required area of longitudinal bars A^*l shall be computed by:

$$\text{EQUATION:} \quad A^*l = 2A_{\tau t} \frac{b_{\tau t} + h_{\tau t}}{s} \quad (54a)$$

or by

$$\text{EQUATION:} \quad A^*l = \left[\frac{400bs}{f_{ry}} \frac{v_{\tau t u}}{v_{\tau t u} + v_{\tau u}} - 2A_{\tau t} \right] \frac{b_{\tau t} + h_{\tau t}}{s} \quad (54b)$$

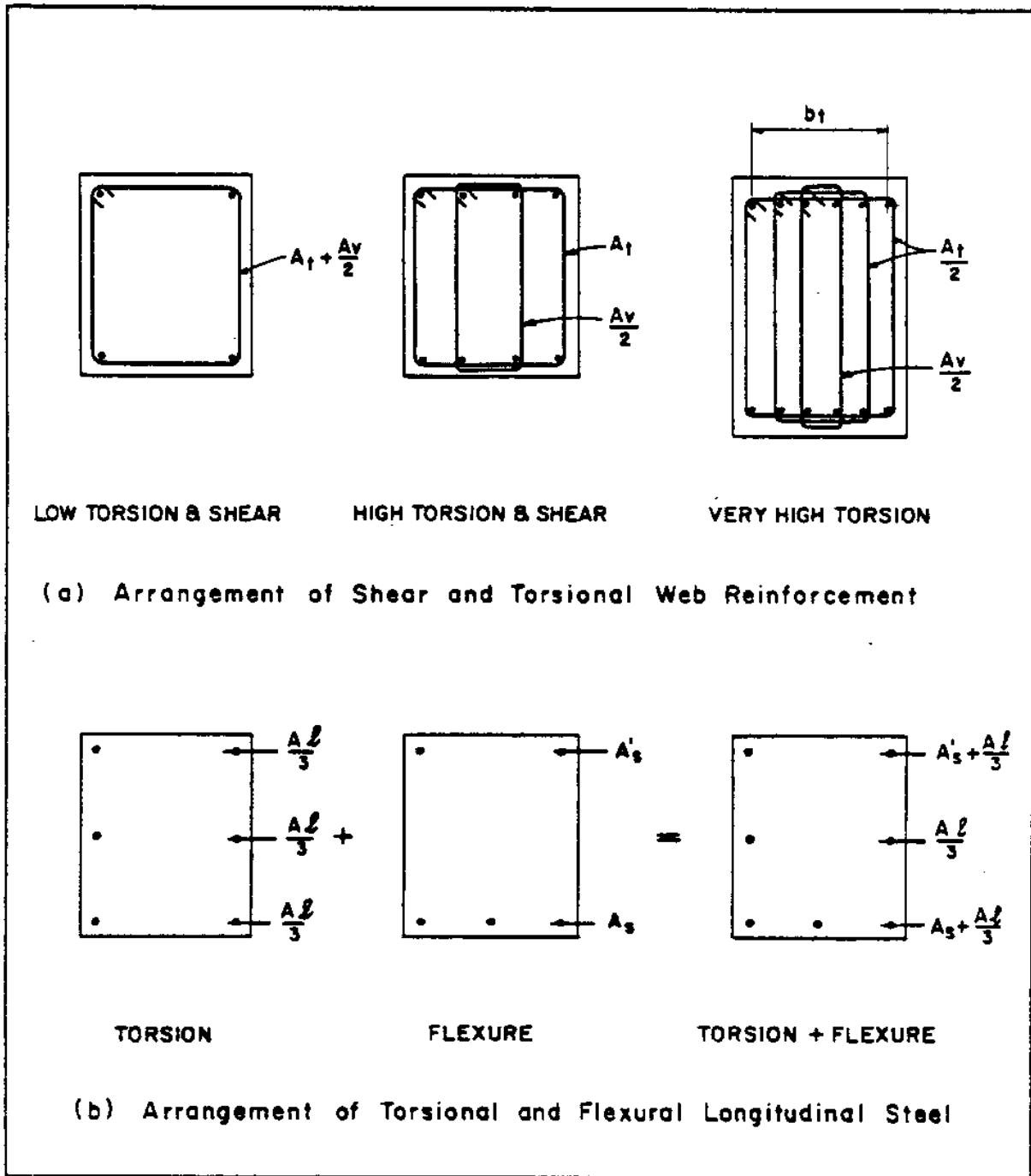

FIGURE 33

Arrangement of Reinforcement for Combined Flexure and Torsion

whichever is greater. When using Equation (54b), the value of $2A_{\tau t}$ shall satisfy the following;

$$\text{EQUATION:} \quad 2A_{\tau t} \geq 50bs/f_{dy} \quad (55)$$

where,

f_{dy} = dynamic yield stress, psi

(11) It should be noted that Equation (54a) requires the volume of longitudinal reinforcement to be equal to the volume of the web reinforcement required by Equation (51) or (52) unless a greater amount of longitudinal reinforcement is required to satisfy the minimum requirements of Equation (54b).

(12) Longitudinal bars should be uniformly distributed around the perimeter of the cross section with a spacing not exceeding 12 inches. At least one longitudinal bar should be placed in each corner of the closed stirrups. A typical arrangement of longitudinal bars is shown in Figure 33b, where torsional longitudinal bars that are located in the flexural tension zone and flexural compression zone may be combined with the flexural steel.

(13) The addition of torsional and flexural longitudinal reinforcement in the flexural compression zone is not reasonable. It is illogical to add torsional steel that is in tension to the flexural steel that is in compression. This method of adding torsional steel to flexural steel regardless of whether the latter is in tension or in compression is adopted purely for simplicity. For blast resistant design, flexural reinforcement added but not included in the calculation of the ultimate resistance could cause a shear failure. The actual ultimate resistance could be significantly greater than the calculated ultimate resistance for which the shear reinforcement is provided. Therefore, torsional longitudinal reinforcement cannot be indiscriminately placed but must be placed only where required.

(14) In the design of a beam subjected to both flexure and torsion, torsional longitudinal reinforcement is first assumed to be uniformly distributed around the perimeter of the beam. The reinforcement required along the vertical face of the beam will always be provided. However, in the flexural compression zone, the reinforcement that should be used is the greater of the flexural compression steel (rebound reinforcement) or the torsional steel. In terms of the typical arrangement of reinforcement in Figure 33b, either $A'_{\tau s}$ or A^*l is used, whichever is greater, as the design steel area in the flexural compression zone. For the tension zone at the mid span of a uniformly loaded beam the torsional stress is zero and torsional longitudinal reinforcement is not added. Conversely, the tension zone at the supports is the location of peak torsional stresses and longitudinal torsional reinforcement must be added to the flexural steel.

g. Dynamic Analysis.

(1) Introduction. The dynamic analysis of beams is performed in the same manner as that given in NAVFAC P-397 for slabs. The data presented for one-way slab elements are applicable for beams. These data plus data for additional support and loading conditions are presented for ease of analysis. Again, it should be pointed out that slab calculations are based on a unit area whereas beam calculations are performed for a unit length of the beam.

(2) Resistance-Deflection Curve for Design. The maximum deflection, X_{max} , of a beam is kept within the elastic, elasto-plastic, and limited plastic ranges. The resistance-deflection function for design takes the form shown in Figure 34. One- and two-step systems are generally used for beams. A three-step function is possible but only for fixed ended beams with unequal negative moment capacities. Response charts are prepared for one-step systems. Consequently the two- and three-step functions are replaced by an equivalent one-step function. Equations for the equivalent functions are presented in NAVFAC P-397.

(3) Ultimate Resistance. The ultimate unit resistance of beams with various support and loading conditions is given in Table 5. For beams, the ultimate moment, M_{max} and M_{min} , is expressed in inch-pounds so that the ultimate unit resistance, r_{max} , is in pounds per inch and the ultimate resistance, R_{max} , for concentrated loads is in pounds.

(4) Elastic and Elasto-Plastic Resistances. The elastic and elasto-plastic resistances of beams with various support and loading conditions is given in Table 6. In those cases where the elasto-plastic resistance is equal to the ultimate resistance, the value can be determined from Table 5.

(5) Elasto-Plastic Stiffness and Deflection. The elastic and elasto-plastic stiffnesses of beams with various support and loading conditions are given in Table 7. Also the equivalent stiffness of each beam is given. It should be noted that the moment of inertia is for the total beam width and carries the dimension of inches to the fourth power. Consequently, the stiffness has the units of pounds per inch per inch. Knowing the resistances and stiffnesses, the corresponding elastic, elasto-plastic, and equivalent elastic deflections can be computed.

(6) Plastic Deflections. The maximum plastic deflection and the ultimate plastic deflection for beams of various support and loading conditions is given in Table 8. The deflection is given as a function of support rotation. The ultimate support rotation of beams is limited to 2 degrees. Tests have indicated that concrete members lose their structural integrity after support rotations in the order of 2 degrees have been achieved.

(7) Support Shears. The support reactions for beams with various support and loading conditions are given in Table 9.

(a) ONE STEP ELASTO-PLASTIC SYSTEM(b) TWO STEP ELASTO-PLASTIC SYSTEM(c) THREE STEP ELASTO-PLASTIC SYSTEM

FIGURE 34

Resistance-Deflection Function for Beams

TABLE 5

Ultimate Unit Resistances for Beams

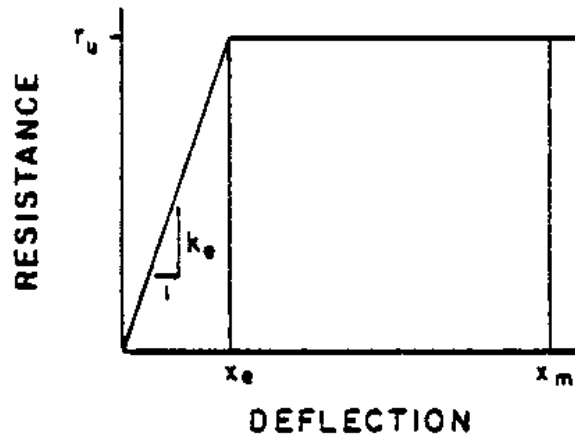
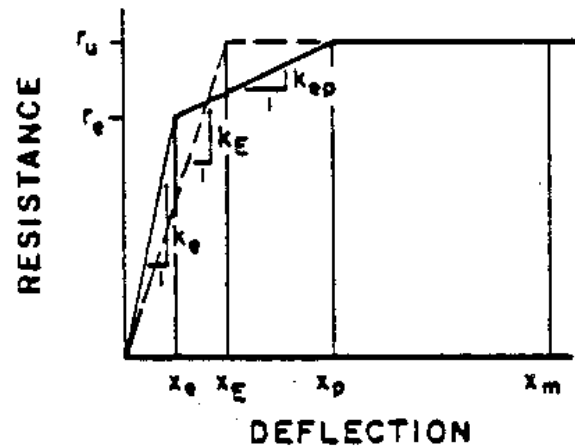
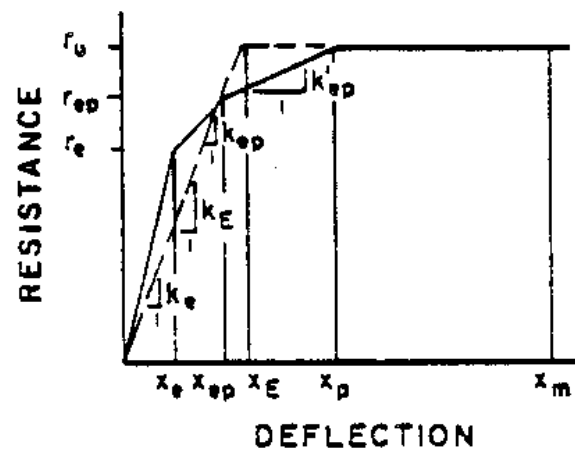
Edge Conditions and Loading Diagrams	Ultimate Resistance
	$r_u = \frac{8 M_p}{L^2}$
	$R_u = \frac{4 M_p}{L}$
	$r_u = \frac{4 (M_N + 2 M_p)}{L^2}$
	$R_u = \frac{2 (M_N + 2 M_p)}{L}$
	$r_u = \frac{8 (M_N + M_p)}{L^2}$
	$R_u = \frac{4 (M_N + M_p)}{L}$
	$r_u = \frac{2 M_N}{L^2}$
	$R_u = \frac{M_N}{L}$
	$R_u = \frac{6 M_p}{L}$

TABLE 6

Elastic and Elasto-Plastic Unit Resistances for Beams



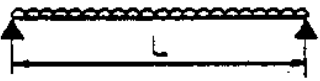
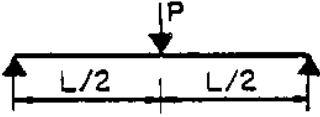
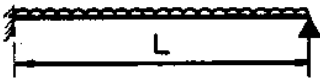
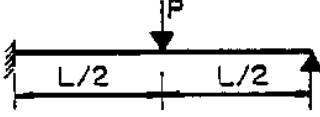
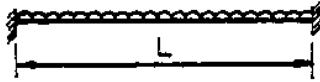
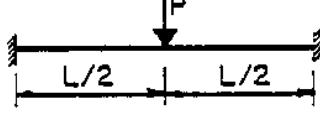
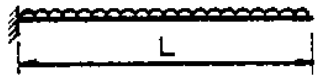
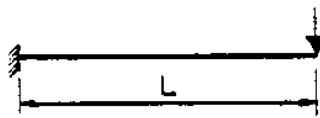
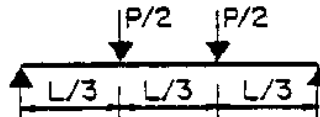

Edge Conditions and Loading Diagrams	Elastic Resistance, r_e	Elasto - Plastic Resistance, r_{ep}
	r_u	—
	R_u	—
	$\frac{8MN}{L^2}$	r_u
	$\frac{16MN}{3L}$	R_u
	$\frac{12MN}{L^2}$	r_u
	$\frac{8MN}{L}$	R_u
	r_u	—
	R_u	—
	R_u	—

TABLE 7

Elastic, Elasto-Plastic and Equivalent Elastic Stiffnesses for Beams

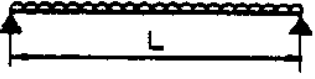
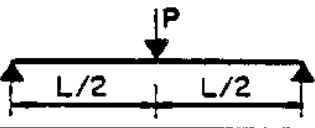
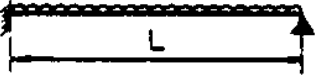
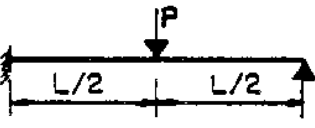
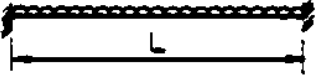
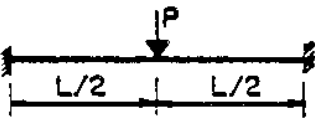
Edge Conditions and Loading Diagrams	Elastic Stiffness, K_e	Elasto-Plastic Stiffness, K_{ep}	Equiv. Elastic Stiffness, K_E
	$\frac{384EI}{5L^4}$	—	$\frac{384EI}{5L^4}$
	$\frac{48EI}{L^3}$	—	$\frac{48EI}{L^3}$
	$\frac{185EI}{L^4}$	$\frac{384EI}{5L^4}$	$\frac{160EI^*}{L^4}$
	$\frac{107EI}{L^3}$	$\frac{48EI}{L^3}$	$\frac{106EI^*}{L^3}$
	$\frac{384EI}{L^4}$	$\frac{384EI}{5L^4}$	$\frac{307EI^*}{L^4}$
	$\frac{192EI}{L^3}$	$\frac{48EI^{**}}{L^3}$	$\frac{192EI^*}{L^3}$
	$\frac{8EI}{L^4}$	—	$\frac{8EI}{L^4}$
	$\frac{3EI}{L^3}$	—	$\frac{3EI}{L^3}$
	$\frac{56.4EI}{L^3}$	—	$\frac{56.4EI}{L^3}$

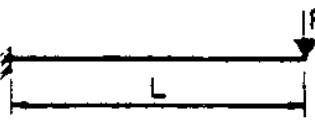
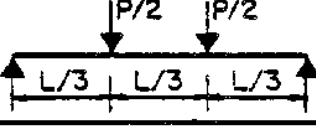
* Valid only if $M_N = M_p$ ** Valid only if $M_N < M_p$

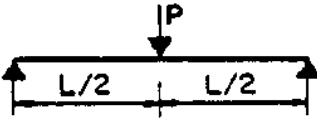
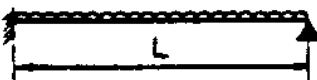
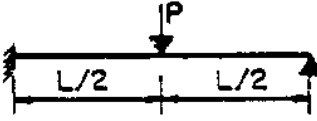
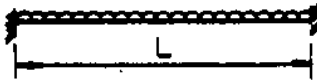
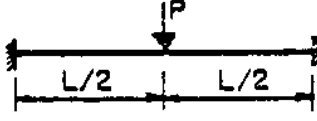
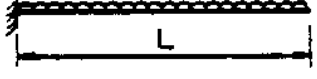
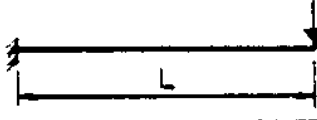
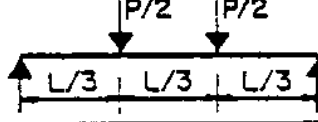
TABLE 8

General and Ultimate Deflections for Beams





Edge Conditions and Loading Diagrams	Maximum Deflection, X_m	Ultimate Deflection, X_u
	$\frac{L}{2} \tan \theta$	$\frac{L}{2} \tan \theta \text{ max}$
	$(L/2) \tan \theta$	$(L/2) \tan \theta \text{ max}$
	$\frac{L}{2} \tan \theta$	$\frac{L}{2} \tan \theta \text{ max}$
	$(L/2) \tan \theta$	$(L/2) \tan \theta \text{ max}$
	$\frac{L}{2} \tan \theta$	$\frac{L}{2} \tan \theta \text{ max}$
	$(L/2) \tan \theta$	$(L/2) \tan \theta \text{ max}$
	$L \tan \theta$	$L \tan \theta \text{ max}$
	$L \tan \theta$	$L \tan \theta \text{ max}$
	$(L/3) \tan \theta$	$(L/3) \tan \theta \text{ max}$

TABLE 9
Support Shears for Beams

Edge Conditions and Loading Diagrams	Support Reactions, V_s
	$\frac{r_u L}{2}$
	$\frac{R_u}{2}$
	L. Reaction $\frac{5r_u L}{8}$ R. Reaction $\frac{3r_u L}{8}$
	L. Reaction $\frac{11R_u}{16}$ R. Reaction $\frac{5R_u}{16}$
	$\frac{r_u L}{2}$
	$\frac{R_u}{2}$
	$r_u L$
	R_u
	$\frac{R_u}{2}$

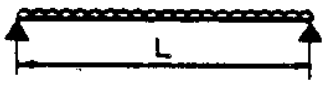
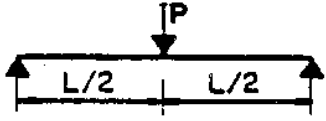
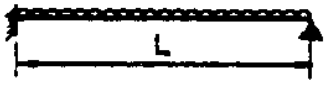
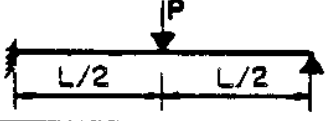
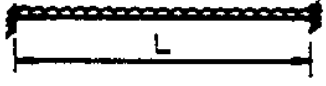
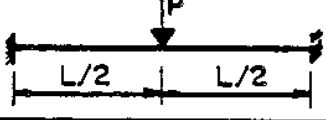
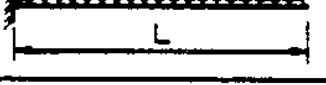
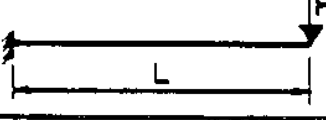
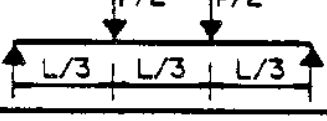
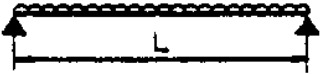
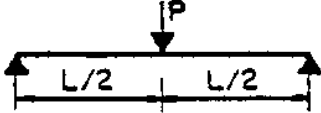
(8) Dynamic Design Factors. The material presented in NAVFAC P-397 is limited to single degree-of-freedom systems only. The design or transformation factors used to convert the actual system to the equivalent dynamic system are contained in Table 10. These factors include the load factor, mass factor, and the load-mass factor for the elastic, elasto-plastic, and plastic ranges of behavior. The load-mass factor is used for the vast majority of design cases. The load and mass factors are required to analyze complex design situations.

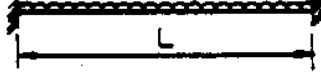
(9) Dynamic Analysis. When a concrete slab supported by beams is subjected to a blast load, the slab and beams act together to resist the load. The beam-slab system is actually a two-mass system and should be treated as such. However, a reasonable design can be achieved by considering the slab and beams separately. That is, the slab and beams are transformed into single degree-of-freedom systems completely independent of each other and are analyzed separately. The dynamic analysis of slabs is treated extensively in NAVFAC P-397 and beams are analyzed in much the same way.

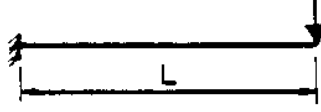
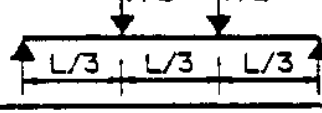
(a) The response of a beam subjected to a dynamic load is defined in terms of its maximum deflection, X_{pm} , and the time, t_{pm} , to reach this maximum deflection. The dynamic load is defined by its peak value, B , and duration, T , while the single degree-of-freedom system is defined in terms of its ultimate resistance, r_{pu} , elastic deflection, X_{pe} , and natural period of vibration, T_{pn} . For the ratios of B/r_{pu} and T/T_{pn} , the ductility ratio, X_{pm}/X_{pe} , and t_{pm}/T are obtained from Figure 6-7 of NAVFAC P-397.

(b) A beam is designed to resist the blast load acting over the tributary area supported by the beam. Therefore, the peak value of the blast load, B , is the product of the unit peak blast pressure and the spacing of the beams. The peak blast load then has the unit of pounds per inch.

(c) In addition to the short term effect of the blast load, a beam must be able to withstand the long term effect of the slab resistance when the response time of the slab is equal to or greater than the duration of the blast load. To insure against premature failure, the ultimate resistance of the beam must be greater than the reaction of the slab applied to the beam as a static load.

(d) Since the supported slab does, in fact, act with the beam, a portion of the mass of the slab acts with the mass of the beam to resist the dynamic load. It is, therefore, recommended that 20 percent of the mass of the slab on each side of the beam be added to the actual mass of the beam. This increased mass is then used to compute the natural period of vibration, T_{pn} , of the beam. It should be noted that in the calculation of T_{pn} the values used for the effective mass and stiffness of the beam depends upon the allowable maximum deflection. When designing for completely elastic behavior, the elastic stiffness is used while, in other cases, the equivalent elasto-plastic stiffness, K_{pe} , is used. The elastic value of the effective mass is used for the elastic range, while, in the elasto-plastic range, the effective mass is the average of the elastic and elasto-plastic values. For plastic deformations, the value of the effective mass is equal to the average of the equivalent elastic value and the plastic value.

TABLE 10
Transformation Factors for Beams

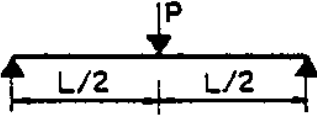
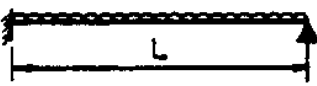
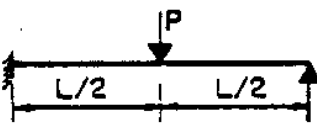
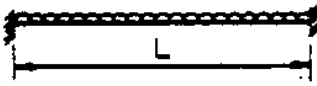
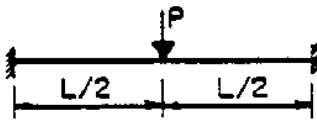
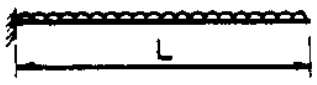
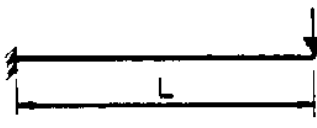
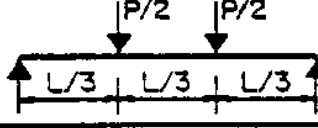
Edge Conditions and Loading Diagrams	Range of Behavior	Load Factor K_L	Mass Factor K_M	Load-Mass Factor K_{LM}
	Elastic Plastic	0.64 0.50	0.50 0.33	0.78 0.66
	Elastic Plastic	1.0 1.0	0.49 0.33	0.49 0.33
	Elastic Elasto-Plastic Plastic	0.58 0.64 0.50	0.45 0.50 0.33	0.78 0.78 0.66
	Elastic Elasto-Plastic Plastic	1.0 1.0 1.0	0.43 0.49 0.33	0.43 0.49 0.33
	Elastic Elasto-Plastic Plastic	0.53 0.64 0.50	0.41 0.50 0.33	0.77 0.78 0.66
	Elastic Plastic	1.0 1.0	0.37 0.33	0.37 0.33
	Elastic Plastic	0.40 0.50	0.26 0.33	0.65 0.66
	Elastic Plastic	1.0 1.0	0.24 0.33	0.24 0.33
	Elastic Plastic	0.87 1.0	0.52 0.56	0.60 0.56

(10) Design for Rebound. The beam must be designed to resist the negative deflection or rebound which occurs after the maximum positive deflection has been reached. The negative resistance, $r^L -J$, attained by the beam when subjected to a triangular pressure-time load, is taken from Figure 6-8 of NAVFAC P-397. Entering the figure with the ratios of $X_{Tm\gamma}/X_{TE\gamma}$ and $T/T_{Tn\gamma}$, previously determined for the positive phase of the design, the ratio of the required rebound resistance to the ultimate resistance, $r^L -J/r_{Tu\gamma}$, is obtained. The beam must be reinforced to withstand this rebound resistance, $r^L -J$, to insure that the beam will remain elastic during rebound.

The tension reinforcement provided to withstand rebound forces is added to what is the compression zone during the initial loading phase. To determine this reinforcement, the required rebound moments are obtained from Table 5 for the appropriate edge and loading conditions. The beam is designed to attain its ultimate resistance in the negative direction, that is, $r^L -J$ is equal to $r_{Tu\gamma}$. The required amount of reinforcement is calculated from Equation (34).

4. DYNAMIC DESIGN OF INTERIOR COLUMNS.

a. General. In a shear wall type structure, the lateral loads are transmitted through the floor and roof slabs to the exterior (and interior, if required) shear walls. Due to the extreme stiffness of the shear walls, there is negligible sidesway in the interior columns and, hence, no induced moments due to lateral loads. Therefore, interior columns are axially loaded members not subjected to the effects of lateral load. However, significant moments can result from unsymmetrical loading conditions.

b. Strength of Compression Members (P-M Curve).

(1) Introduction.

(a) The capacity of a short compression member is based primarily on the strength of its cross section. The behavior of the member encompasses that of both a beam and a column. The degree to which either behavior predominates depends upon the relative magnitudes of the axial load and moment. The capacity of the column can be determined by constructing an interaction diagram as shown in Figure 35. This curve is a plot of the column axial load capacity versus the moment it can simultaneously withstand. Points on this diagram are calculated to satisfy both stress and strain compatibility. A single curve would be constructed for a given cross section with a specified quantity of reinforcement. The plot of a given loading condition that falls within this area represents a loading combination that the column can support, whereas a plot that falls outside the interaction curve represents a failure combination.

(b) Three points of the interaction diagram are used to define the behavior of compression members under combined axial and flexural loads. These points are: (1) pure compression ($P_{T0\gamma}$, $M = 0$), (2) pure flexure ($P = 0$, $M_{T0\gamma}$), and (3) balanced conditions ($P_{Tb\gamma}$, $M_{Tb\gamma}$). The eccentricity of the design axial load for the condition of pure compression is zero. However, under actual conditions, pure axial load will rarely, if ever, exist. Therefore, the maximum axial load is limited by a minimum eccentricity, $e_{Tmin\gamma}$. At balanced conditions, the eccentricity is defined as $e_{Tb\gamma}$ while the eccentricity at pure flexure is infinity. The strength of a section is controlled by compression when the design eccentricity, $e = M_{Tu\gamma}/P_{Tu\gamma}$, is smaller than the eccentricity under balanced conditions. The strength of the section is controlled by tension when the design eccentricity is greater than that for balanced conditions.

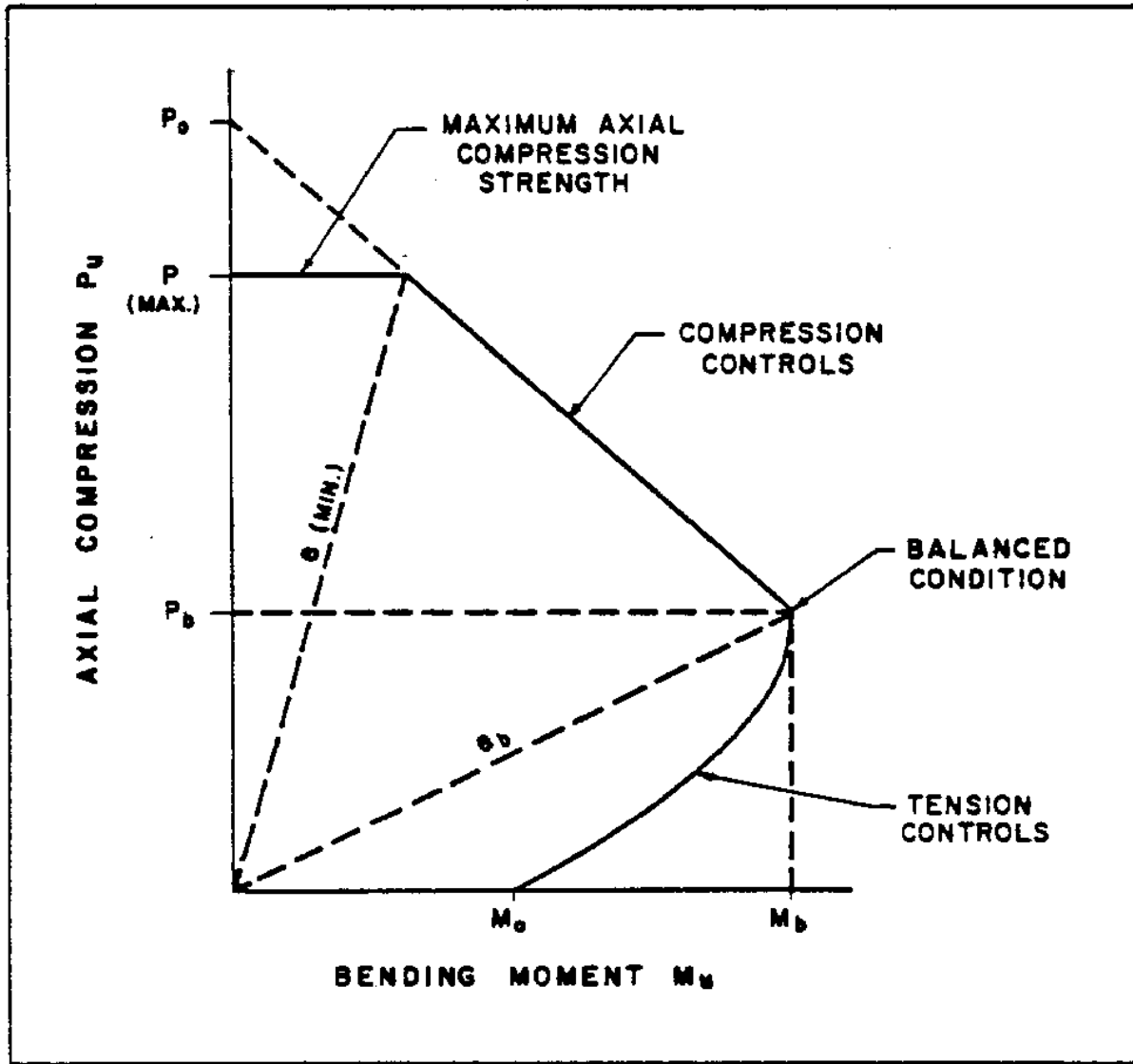

FIGURE 35
Column Interaction Diagram

(2) Pure Compression.

(a) The ultimate dynamic strength of a short reinforced concrete column subjected to pure axial load (no bending moments) is given by:

$$\text{EQUATION:} \quad P_{\text{max}} = 0.85 f'_c (A_g - A_{st}) + A_{st} f_y \quad (56)$$

where,

P_{max} = maximum axial load, lb

A_g = gross area of section, in²

A_{st} = total area of reinforcing steel, in²

(b) A member subjected to pure axial compression is a hypothetical situation since all columns are subjected to some moment due to actual load conditions. All tied and spiral columns must be designed for a minimum load eccentricity. This minimum design situation is presented in a subsequent section.

(3) Pure Flexure. An interior column of a shear wall type structure cannot be subjected to pure flexure under normal design conditions. For the purpose of plotting a P-M curve, the criteria presented for beams is used.

(4) Balanced Conditions.

(a) A balanced strain condition for a column subjected to a dynamic load is achieved when the concrete reaches its limiting strain of 0.003 in/in simultaneously with the tension steel reaching its dynamic yield stress, f_y . This condition occurs under the action of the balanced load, P_b , and the corresponding balanced moment, M_b . At balanced conditions, the eccentricity of the load is defined as e_b , and is given by:

$$\text{EQUATION:} \quad e_b = M_b / P_b \quad (57)$$

(b) The actual values of the balanced load and corresponding balanced moment are generally not required. The balanced eccentricity is the important parameter, since a comparison of the actual eccentricity to the balanced eccentricity distinguishes whether the strength of the section is controlled by tension or compression. The comparison of the actual eccentricity to the balanced eccentricity dictates the choice of the appropriate equation for calculating the ultimate axial load capacity, P_u .

(c) Approximate expressions have been derived for the balanced eccentricity for both rectangular and circular members. These expressions are sufficiently accurate for design purposes. For a rectangular tied column with equal reinforcement on opposite faces, Figure 36a, the balanced eccentricity is given by:

$$\text{EQUATION:} \quad e_{rb} = 0.20h + \frac{1.54mA_{rs}}{b} \quad (58)$$

and

$$\text{EQUATION:} \quad m = f_{rdy} / 0.85 f'_{rdc} \quad (59)$$

where,

e_{rb} = balanced eccentricity, in
 h = depth of rectangular section, in
 b = width of rectangular section, in
 A_{rs} = area of reinforcement on one face of the section, in²

For a circular section with spiral reinforcement, Figure 36b, the balanced eccentricity is given by:

$$\text{EQUATION:} \quad e_{rb} = (0.24 + 0.39 p_{rt} m) D \quad (60)$$

and

$$\text{EQUATION:} \quad p_{rt} = A_{rst} / A_{rg} \quad (61)$$

where,

p_{rt} = total percentage of reinforcement
 A_{rst} = total area of reinforcement, in²
 A_{rg} = gross area of circular section, in²
 D = overall diameter of circular section, in

(5) Compression Controls.

(a) When the ultimate eccentric load, P_{ru} , exceeds the balanced value, P_{rb} , or when the eccentricity, e , is less than the balanced value, e_{rb} , the member acts more as a column than as a beam. Failure of the section is initiated by crushing of the concrete. When the concrete reaches its ultimate strain, the tension steel has not reached its yield point and may actually be in compression rather than tension. The ultimate eccentric load at a given eccentricity, e , less than e_{rb} may be obtained by considering the actual strain variation as the unknown and using the principles of statics. However, equations have been developed by Whitney in the paper Plastic Theory of Reinforced Concrete Design which approximate the capacity of the column. These approximate procedures are adequate for design purposes.

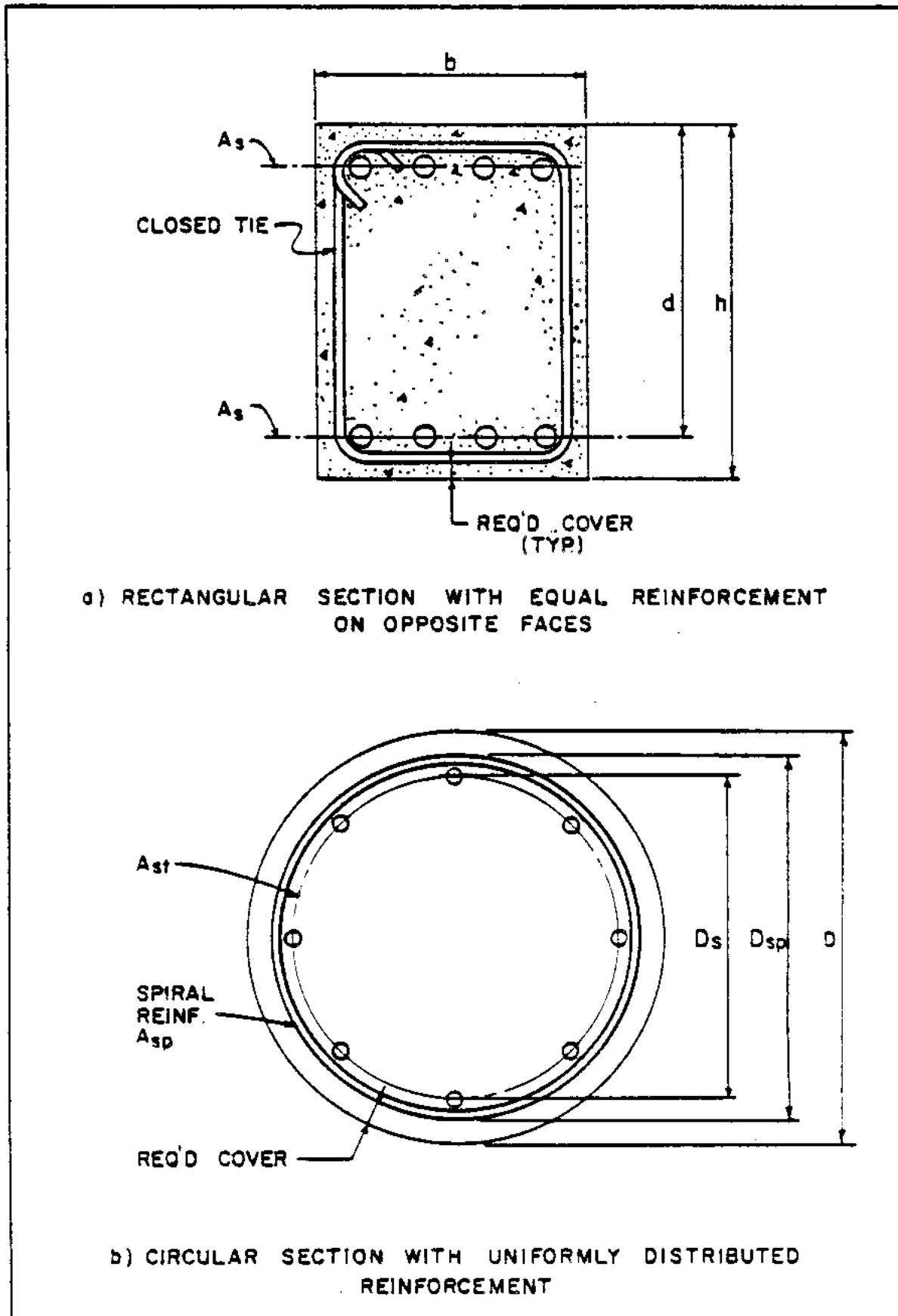

FIGURE 36

Typical Interior Column Sections

(b) For a rectangular tied column with equal reinforcement on opposite faces (Figure 36a), the ultimate axial load capacity at a given eccentricity is approximated by:

$$\text{EQUATION: } P_{\Gamma u \Gamma} = \frac{A_{\Gamma s \Gamma} f_{\Gamma d y \Gamma}}{e / (2d - h) + 0.5} + \frac{bh f'_{\Gamma d c \Gamma}}{3he / d L_2^2 + 1.18} \quad (62)$$

where,

$P_{\Gamma u \Gamma}$ = ultimate axial load at e , lb
 e = actual eccentricity of applied load
 $A_{\Gamma s \Gamma}$ = area of reinforcement on one face of the section, in²
 d = distance from extreme compression fiber to centroid of tension reinforcement, in
 h = depth of rectangular section, in
 b = width of rectangular section, in

For a circular section with spiral reinforcement, the ultimate axial load capacity at a given eccentricity is approximated by:

$$\text{EQUATION: } P_u = \frac{A_{st} f_{dy}}{\frac{3e}{D_s} + 1.0} + \frac{A_g f'_{dc}}{\frac{9.6De}{(0.8D + 0.67 D_s)^2} + 1.18} \quad (63)$$

where,

A_{st} = total area of uniformly distributed longitudinal reinforcement, in²
 A_g = gross area of circular section, in²
 D = overall diameter of circular section, in
 D_s = diameter of the circle through centers of reinforcement arranged in a circular pattern.

(6) Tension Controls.

(a) When the ultimate eccentric load, $P_{\Gamma u \Gamma}$, is less than the balance value, $P_{\Gamma b \Gamma}$, or when the eccentricity, e , is greater than the balanced value, $e_{\Gamma b \Gamma}$, the member acts more as a beam than as a column. Failure of the section is initiated by yielding of the tension steel. The ultimate eccentric load at a given eccentricity, e , greater than $e_{\Gamma b \Gamma}$ may be obtained by considering the actual strain variation as the unknown and using the principles of statics. However, Whitney's equations may again be used to approximate the capacity of the column. It should be pointed out that while tension controls a possible design situation it is not a usual condition for interior columns of a shear wall type structure.

(b) For a rectangular tied column with equal reinforcement on opposite faces (Figure 36a), the ultimate axial load capacity at a given eccentricity is approximated by:

EQUATION:

$$P_{\Gamma u\gamma} = 0.85 f'_{\Gamma dc\gamma} bd \left[1 - p - \frac{e'}{d} + \left[\frac{(1-e') L_2}{d} + 2p \frac{(m-1)(2-h)}{d} + \frac{e'}{d} \right] \frac{L_1}{2} \right] \quad (64)$$

in which,

$$\text{EQUATION:} \quad p = \frac{A_{\Gamma s\gamma}}{bd} \quad (65)$$

$$\text{EQUATION:} \quad e' = e + d - \frac{h}{2} \quad (66)$$

$$\text{EQUATION:} \quad m = \frac{f_{\Gamma dy\gamma}}{0.85 f'_{\Gamma dc\gamma}} \quad (67)$$

where,

- p = percentage of reinforcement on one face of section
- e' = eccentricity of axial load at end of member measured from the centroid of the tension reinforcement, in

(c) For a circular section with spiral reinforcement, Figure 36b, the ultimate axial load capacity at a given eccentricity is approximated by:

$$\text{EQUATION:} \quad P_{\Gamma u\gamma} = 0.85 f'_{\Gamma dc\gamma} D L_2 \left[\left[\frac{0.85e}{D} - 0.38 \right] L_2 + \frac{L_p t_{\Gamma mD} s}{2.5 D} \right] \frac{L_1}{2} - \left(\frac{0.85e}{D} - 0.38 \right) \quad (68)$$

where,

$p_{\Gamma t\gamma}$ = total percentage of reinforcement and is defined in Equation (61).

c. Slenderness Effects.

(1) General.

(a) The preceding section discussed the capacity of short compression members. The strength of these members is based primarily on their cross section. The effects of buckling and lateral deflection on the strength of these short members are small enough to be neglected. Such members are not in danger of buckling prior to achieving their ultimate strength based on the properties of the cross section. Further, the lateral deflections of short compression members subjected to bending moments are small, thus contributing little secondary bending moment (axial load, P , multiplied by lateral deflection). These buckling and deflection effects reduce the ultimate strength of a compression member below the value given in the preceding section for short columns.

(b) In the design of columns for blast resistant buildings, the use of short columns is preferred. The cross section is selected for the given height and support conditions of the column in accordance with criteria presented below for short columns. If the short column cross section results in a capacity much greater than required, the dimensions may be reduced to achieve an economical design. However, slenderness effects must be evaluated to insure an adequate design. It should be noted that for shear wall type structures, the interior columns are not subjected to sidesway deflections since lateral loads are resisted by the stiff shear walls. Consequently, slenderness effects due to buckling and secondary bending moments ($P[W-DELTA]$) are the only effects that must be considered.

(2) Slenderness Ratio.

(a) The unsupported length, $L_{\Gamma U \Gamma}$, of a compression member is taken as the clear distance between floor slabs, beams, or other members capable of providing lateral support for the compression member. Where column capitals or haunches are present, the unsupported length is measured to the lower extremity of capital or haunch in the plane considered.

(b) The effective length of a column, $kL_{\Gamma U \Gamma}$, is actually the equivalent length of a pin ended column. For a column with pin ends, the effective length is equal to the actual unsupported length ($k = 1.0$). Where translation of the column at both ends is adequately prevented (braced column), the effective length of the column is the distance between points of inflection (k less than 1.0). It is recommended that for the design of columns in shear wall type structures, the effective length factor, k , may be taken as 0.9 for columns that are definitely restrained by beams and girders at the top and bottom. For all other cases k shall be taken as 1.0 unless analysis shows that a lower value may be used.

(c) For columns braced against sidesway, the effects of slenderness may be neglected when:

$$\text{EQUATION:} \quad \frac{kL_{\Gamma U \Gamma}}{r} < 34 - 12 \frac{M_{\Gamma 1 \Gamma}}{M_{\Gamma 2 \Gamma}} \quad (69)$$

where,

- k = effective length factor
- L_{u} = unsupported length of column, in
- r = radius of gyration of cross section of column, in
(r = 0.3h for tied columns and 0.25D for circular columns)
- M_{1} = value of smaller end moment on column, positive if member is bent in single curvature and negative if bent in double curvature, in-lb
- M_{2} = value of larger end moment on column, in-lb

In lieu of a more accurate analysis, the value of $M_{\text{1}}/M_{\text{2}}$ may conservatively be taken equal to 1.0. Therefore, in the design of columns the effect of slenderness may be neglected when:

$$\text{EQUATION: } \frac{kL_{\text{u}}}{r} < \leq 22 \quad (70)$$

(d) The use of slender columns is not permitted in order to avoid stability problems. Consequently, the slenderness ratio must be limited to a maximum value of 50.

(3) Moment Magnification.

(a) Slenderness effects due to buckling and secondary bending moments must be considered in the design of columns whose slenderness ratio is greater than that given by Equation (69). The reduction in the ultimate strength of a slender column is accounted for in the design procedure by increasing the design moment. The cross section and reinforcement is thereby increased above that required for a short column.

(b) A column braced against sidesway is designed for the applied axial load P and a magnified moment M defined by:

$$\text{EQUATION: } M = [\text{delta}] M_{\text{2}} \quad (71)$$

in which

$$\text{EQUATION: } [\text{delta}] = \frac{C_{\text{m}}}{1 - P/P_{\text{c}}} \quad (72)$$

where

- M = design moment, in-lb
- [delta] = moment magnifier (greater than 1.0)
- M_{2} = value of larger end moment on column, in-lb
- C_{m} = equivalent moment factor given by Equation (73)
- P = design axial load, lb
- P_{c} = critical axial load causing buckling defined by Equation (74), lb

(c) For columns braced against sidesway and not subjected to transverse loads between supports, i.e., interior columns of shear wall type structures, the equivalent moment factor, $C_{m\gamma}$, may be taken as:

$$\text{EQUATION:} \quad C_{m\gamma} = 0.6 + 0.4 \frac{M_{\gamma 1}}{M_{\gamma 2}} \quad (73)$$

The value of $C_{m\gamma}$ may not under any circumstances be taken less than 0.4. In lieu of a more accurate analysis, the value of $M_{\gamma 1}/M_{\gamma 2}$ may conservatively be taken equal to 1.0. Therefore, in the design of interior columns, $C_{m\gamma}$ may be taken as 1.0.

(d) The critical axial load that causes a column to buckle is given by:

$$\text{EQUATION:} \quad P_{\gamma c} = \frac{[\pi]^2 EI}{(kL_{\gamma})^2} \quad (74)$$

In order to apply Equation (74), a realistic value of EI must be obtained for the section at buckling. An approximate expression for EI at the time of buckling is given by:

$$\text{EQUATION:} \quad EI = \frac{E_{\gamma c} I_{\gamma a}}{1.5} \quad (75)$$

in which

$$\text{EQUATION:} \quad I_{\gamma a} = \frac{I_{\gamma g} + I_{\gamma c}}{2} \quad (76)$$

and

$$\text{EQUATION:} \quad I_{\gamma c} = Fbd^3 \quad (77)$$

where,

$I_{\gamma a}$ = average moment of inertia of section, in⁴

$I_{\gamma g}$ = moment of inertia of gross concrete section about centroidal axis, neglecting reinforcement, in⁴

$I_{\gamma c}$ = moment of inertia of cracked concrete section with equal reinforcement on opposite faces, in⁴

F = coefficient given in Figure 37

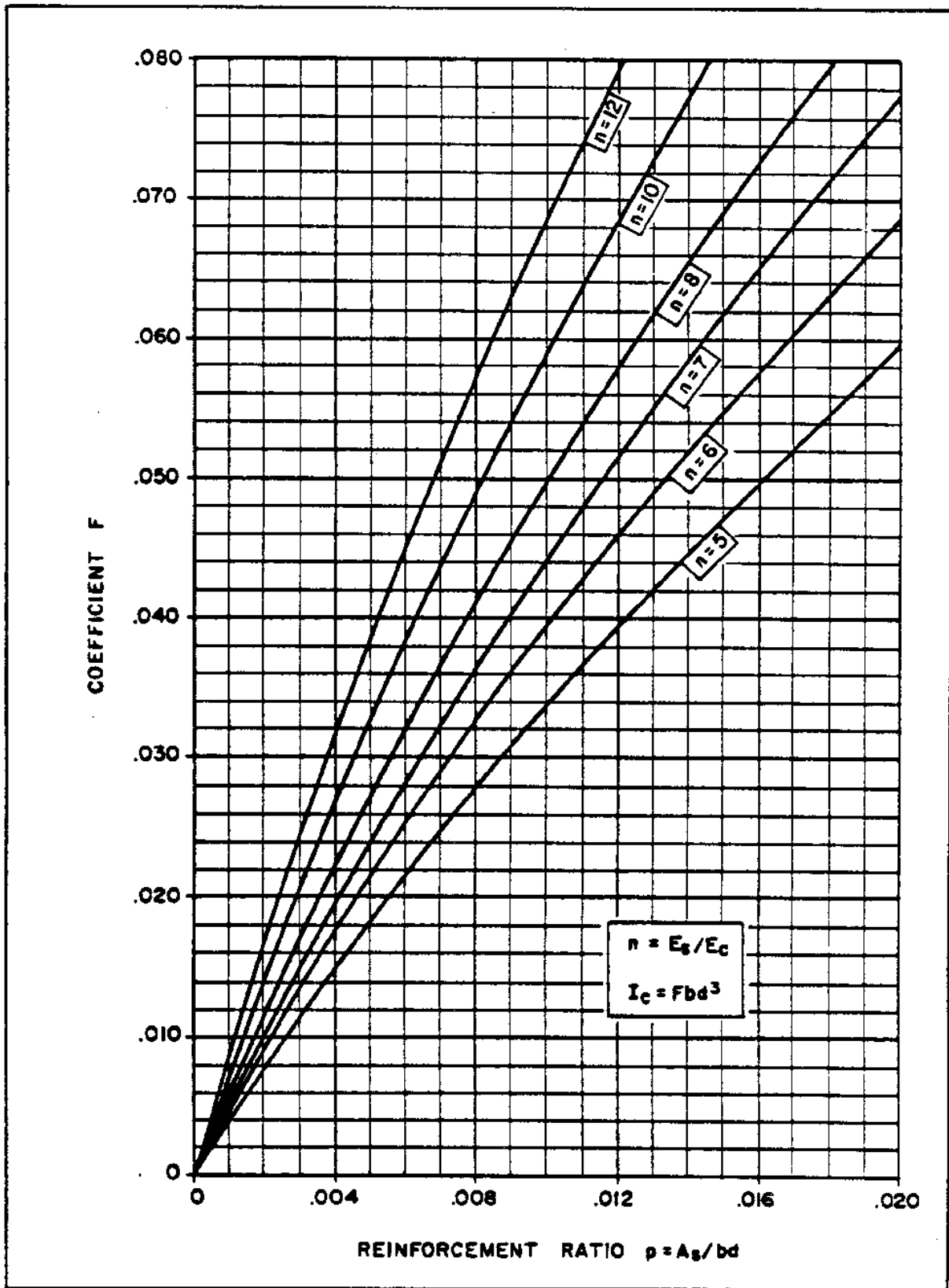

FIGURE 37
Coefficients for Moment of Inertia of Cracked Section
with Equal Reinforcement on Opposite Faces

d. Dynamic Analysis.

(1) Columns are not subjected to the blast loading directly. Rather, the load that a column must resist is transmitted through the roof slab, beams, and girders. These members "filter" the dynamic effects of the blast load. Thus, the dynamic load reaching the columns is typically a fast "static" load, that is, a flat top pressure time load with a relatively long rise time.

(2) The roof members and columns act together to resist the applied blast load. However, a reasonable design can be achieved by considering the column separately from the roof members. The response (resistance-time function) of the roof members to the blast load is taken as the applied dynamic load acting on the columns.

(3) Columns are subjected to an actual axial load (with associated eccentricity) equal to the ultimate resistance of the appropriate roof members acting over the tributary area supported by the column. It is recommended for design of columns the ultimate axial load be equal to 1.2 times the actual axial load. This increase insures that the maximum response of the column will be limited to a ductility ratio, X_{Tm}/X_{TE} , of 3.0 or less. If the rise time of the load (time to reach yield for the appropriate roof members) divided by the natural period of the column is small (approximately 0.1), the maximum ductility is limited to 3.0. Whereas, if the time ratio is equal to or greater than 1.0, the column will remain elastic. For the usual design cases, the ratio of the rise time to the natural period will be in the vicinity of 1.0. Therefore, the columns will remain elastic or, at best, sustain slight plastic action.

e. Design of Tied Columns.

(1) Interior columns are not usually subjected to excessive bending moments since sidesway is eliminated by the shear walls. However, significant moments about both axes can result from unsymmetrical loading conditions. These moments may be due to unequal spacing between columns or to time phasing of the applied loads. As a result of the complex load conditions, the columns must be proportioned considering bending about both the x- and y-axes simultaneously.

(2) One method of analysis is to use the basic principles of equilibrium with the acceptable ultimate strength assumptions. This method essentially involves a trial and error process for obtaining the position of an inclined neutral axis. This method is sufficiently complex so that no formula may be developed for practical use.

(3) An approximate design method has been developed which gives satisfactory results for biaxial bending. The equation is in the form of an interaction formula which for design purposes can be written in the form:

$$\text{EQUATION:} \quad \frac{1}{P_{Tuz}} = \frac{1}{P_{Tx}} + \frac{1}{P_{Ty}} - \frac{1}{P_{To}} \quad (78)$$

where

- $P_{\Gamma U\gamma}$ = ultimate load for biaxial bending with eccentricities $e_{\Gamma X\gamma}$ and $e_{\Gamma Y\gamma}$
 $P_{\Gamma X\gamma}$ = ultimate load when eccentricity $e_{\Gamma X\gamma}$ is present ($e_{\Gamma Y\gamma} = 0$)
 $P_{\Gamma Y\gamma}$ = ultimate load when eccentricity $e_{\Gamma Y\gamma}$ is present ($e_{\Gamma X\gamma} = 0$)
 $P_{\Gamma O\gamma}$ = ultimate load for concentrically loaded column ($e_{\Gamma X\gamma} = e_{\Gamma Y\gamma} = 0$)

Equation (78) is valid provided $P_{\Gamma U\gamma}$ is equal to or greater than $0.10P_{\Gamma O\gamma}$. The usual design cases for interior columns satisfy this limitation. The equation is not reliable where biaxial bending is prevalent and is accompanied by an axial force smaller than $0.10P_{\Gamma O\gamma}$. In the case of strongly prevalent bending, failure is initiated by yielding of the steel (tension controls region of P-M curve). In this range it is safe and satisfactorily accurate to neglect the axial force entirely and to calculate the section for biaxial bending only. This procedure is conservative since the addition of axial load in the tension controls region increases the moment capacity. It should be mentioned that the tension controls case would be unusual and, if possible, should be avoided in the design.

(4) Reinforcement must be provided on all four faces of a tied column with the reinforcement on opposite faces of the column equal. In applying Equation (78) to the design of tied columns, the values of $P_{\Gamma X\gamma}$ and $P_{\Gamma Y\gamma}$ are obtained from Equation (62) and (64) for the regions where compression and tension control the design, respectively. The equations are for rectangular columns with equal reinforcement on the faces of the column parallel to the axis of bending. Consequently, in the calculation of $P_{\Gamma X\gamma}$ and $P_{\Gamma Y\gamma}$, the reinforcement perpendicular to the axis of bending is neglected. Conversely, the total quantity of reinforcement provided on all four faces of the column is used to calculate $P_{\Gamma O\gamma}$ from Equation (56). Calculation of $P_{\Gamma X\gamma}$, $P_{\Gamma Y\gamma}$, and $P_{\Gamma O\gamma}$ in the manner described will yield a conservative value of $P_{\Gamma U\gamma}$ from Equation (78).

(5) Due to the possible complex load conditions that can result in blast design, all tied columns shall be designed for biaxial bending. If computations show that there are no moments at the ends of the column or that the computed eccentricity of the axial load is less than $0.1h$, the column must be designed for a minimum eccentricity equal to $0.1h$. The value of h is the depth of the column in the bending direction considered. The minimum eccentricity shall apply to bending in both the x and y directions, simultaneously.

(6) To insure proper behavior of a tied column, the longitudinal reinforcement must meet certain restrictions. The area of longitudinal reinforcement shall not be less than 0.01 nor more than 0.04 times the gross area of the section. A minimum of 4 reinforcing bars shall be provided. The size of the longitudinal reinforcing bars shall not be less than No. 6 nor larger than No. 11. The use of No. 14 and No. 18 bars as well as the use of bundled bars are not recommended due to problem associated with the development and anchorage of such bars. To permit proper placement of the concrete, the minimum clear distance between longitudinal bars shall not be less than 1.5 times the nominal diameter of the longitudinal bars or less than 1.5 inches.

(7) Lateral ties must enclose all longitudinal bars in compression to insure their full development. These ties must conform to the following:

(a) The ties shall be at least No. 3 bars for longitudinal bars No. 8 or smaller and at least No. 4 bars for No. 9 longitudinal bars or greater.

(b) To insure the full development of the ties, they shall be closed using 135-degree hooks. The use of 90-degree bends is not recommended.

(c) The vertical spacing of the ties shall not exceed 16 longitudinal bar diameters, 48 tie diameters, or 1/2 of the least dimension of the column section.

(d) The ties shall be located vertically not more than 1/2 the tie spacing above the top of footing or slab and not more than 1/2 the tie spacing below the lowest horizontal reinforcement in a slab or drop panel. Where beams frame into a column, the ties may be terminated not more than 3 inches below the lowest reinforcement in the shallowest of the beams.

(e) The ties shall be arranged such that every corner and alternate longitudinal bar shall have lateral support provided by the corner of a tie with an included angle of not more than 135 degrees and no bar shall be farther than 6 inches clear on each side along the tie from such a laterally supported bar.

(8) The above requirements for the lateral ties are to insure against buckling of the longitudinal reinforcement in compression. However, if the section is subjected to large shear or torsional stresses, the closed ties must be increased in accordance with the provisions established for beams.

f. Design of Spiral Columns

(1) Spiral columns may be subjected to significant bending moments about both axes and should therefore be designed for biaxial bending. However, due to the uniform distribution of the longitudinal reinforcement in the form of a circle, the bending moment (or eccentricities) in each direction can be resolved into a resultant bending moment (or eccentricity). The column can then be designed for uniaxial bending using Equations (63) and (68) for the regions where compression and tension controls the design, respectively.

(2) Since spiral columns show greater toughness than tied columns, particularly when eccentricities are small, the minimum eccentricity for spiral columns is given as $0.05D$ in each direction rather than $0.1h$ in each direction for tied columns. The resultant minimum eccentricity for a spiral column is then equal to $0.0707D$. Therefore, if computations show that there are no moments at the ends of a column or that the computed resultant eccentricity of the axial load is less than $0.0707D$, the column must be designed for a resultant minimum eccentricity of $0.0707D$.

(3) To insure proper behavior of a spiral reinforced column, the longitudinal reinforcement must meet the same restrictions given for tied columns concerning minimum and maximum area of reinforcement, smallest and largest reinforcing bars permissible and the minimum clear spacing between bars. The only difference is that for spiral columns the minimum number of longitudinal bars shall not be less than 6 bars.

(4) Continuous spiral reinforcing must enclose all longitudinal bars in compression to insure their full development. The required area of spiral reinforcement, $A_{\Gamma sp\gamma}$, is given by:

$$\text{EQUATION:} \quad A_{\Gamma sp\gamma} = 0.1125 s D_{\Gamma sp\gamma} \left(\frac{D_{\Gamma sp\gamma}}{D_{\Gamma sp\gamma}} - 1 \right) \frac{f'_{\Gamma c\gamma}}{f_{\Gamma y}} \quad (79)$$

where,

$A_{\Gamma sp\gamma}$ = area of spiral reinforcement, in²
 s = pitch of spiral, in
 D = overall diameter of circular section, in
 $D_{\Gamma sp\gamma}$ = diameter of the spiral measured through the centerline of the spiral bar

The spiral reinforcement must conform to the following:

(a) Spiral column reinforcement shall consist of evenly spaced continuous spirals composed of continuous No. 3 bars or larger. Circular ties are not permitted.

(b) The clear spacing between spirals shall not exceed 3 inches nor be less than 1 inch.

(c) Anchorage of spiral reinforcement shall be provided by 1-1/2 extra turns of spiral bar at each end.

(d) Splices in spiral reinforcement shall be lap splices equal to 1-1/2 turns of spiral bar.

(e) Spirals shall extend from top of footing or slab to level of lowest horizontal reinforcement in members supported above.

(f) In columns with capitals, spirals shall extend to a level at which the diameter or width of capital is two times that of the column.

g. Design for Rebound. To account for rebound forces acting on a tied or spiral column, the longitudinal reinforcement must be properly anchored into the foundations and into the members supported above. The anchorage lengths used must provide for the full tensile strength of the bars.

5. DYNAMIC DESIGN OF EXTERIOR COLUMNS.

a. Introduction.

(1) Exterior columns may be required for severe loading conditions. These columns could be monolithic with the exterior walls and as such would be subjected to both axial and transverse loading. The axial load results from the direct transfer of floor and roof beam reactions while the transverse load is due to the direct impact of the blast load.

(2) The use of exterior columns would normally be restricted to use in framed structures to transfer roof and floor beam reactions to the foundation. Normally, only tied columns would be used since they are compatible with the placement of wall and beam reinforcement. Exterior columns are not normally required for flat slab structures since roof and floor loads are uniformly transmitted to the exterior walls.

b. Design of Exterior Columns.

(1) Exterior columns are generally designed as beam elements. The axial load on these columns may be significant, but usually the effect of the transverse load is greater. The column will usually be in the tension controls region ($e > e_{rb}$) of the P-M curve (Figure 35) where the addition of axial load increases the moment capacity of the member. Consequently, the design of an exterior column as a beam, where the axial load is neglected, is conservative.

(2) Since an exterior column is a primary member which is subjected to an axial load, it is not permitted to attain large plastic deformations. Therefore, the lateral deflection of exterior columns must be limited to a maximum ductility, X_{rm}/X_{rE} , of 3.

6. EXAMPLE PROBLEMS.

a. Design of a Beam.

Problem: Design an interior beam of a roof subject to an overhead blast loading.

Given:

- (1) Structural configuration.
- (2) Pressure-time loading.
- (3) Deflection criteria.
- (4) Material properties.

Solution:

- (1) Calculate dynamic strength of materials from Table 5-3 of NAVFAC P-397 and Equations (32) and (33).
- (2) Assume reinforcing steel and concrete cover.
- (3) Check maximum and minimum steel ratios using Equations (36), (37), and (42)
- (4) Determine moment capacity of the sections using Equations (34) and (35)
- (5) Find ultimate resistance of the beam using Table 5.

- (6) Determine average moment of inertia of the beam from Chapter 5, Section II of NAVFAC P-397.
- (7) Find equivalent elasto-plastic stiffness, $K_{\Gamma E_{\Gamma}}$, of the beam using Table 7.
- (8) Calculate equivalent elastic deflection, $X_{\Gamma E_{\Gamma}}$.
- (9) Determine load-mass factor for the beam using Table 10.
- (10) Determine natural period of the beam using Equation 6-15 of NAVFAC P-397.
- (11) Determine ductility ratio, $X_{\Gamma m_{\Gamma}}/X_{\Gamma E_{\Gamma}}$, from Figure 6-7 of NAVFAC P-397.
- (12) Check rotation using Table 8.
- (13) Check direct shear using Equation (46) and Table 28.
- (14) Determine diagonal tension stress at critical section using Equation (43).
- (15) Determine maximum shear capacity of the unreinforced web using Equation (44).
- (16) Find required area of web reinforcing from Equation (45).
- (17) Check minimum tie reinforcing area and maximum tie spacing.
- (18) Determine required resistance for rebound of the beam using Figure 6-8 of NAVFAC P-397.
- (19) Assume reinforcing steel for rebound.
- (20) Repeat Steps (3) to (5) to satisfy required resistance for rebound.

Calculation:

Given:

- (1) Structural configuration is shown in Figure 38a.
- (2) Pressure Time Loading is shown in Figure 38c.
- (3) Maximum support rotation of one degree.
- (4) Yield stress of reinforcing steel, $f_{\Gamma y_{\Gamma}} = 60,000$ psi and concrete compressive strength, $f'_{\Gamma c_{\Gamma}} = 4,000$ psi.

Weight of concrete, $w = 150$ lbs/ft³.

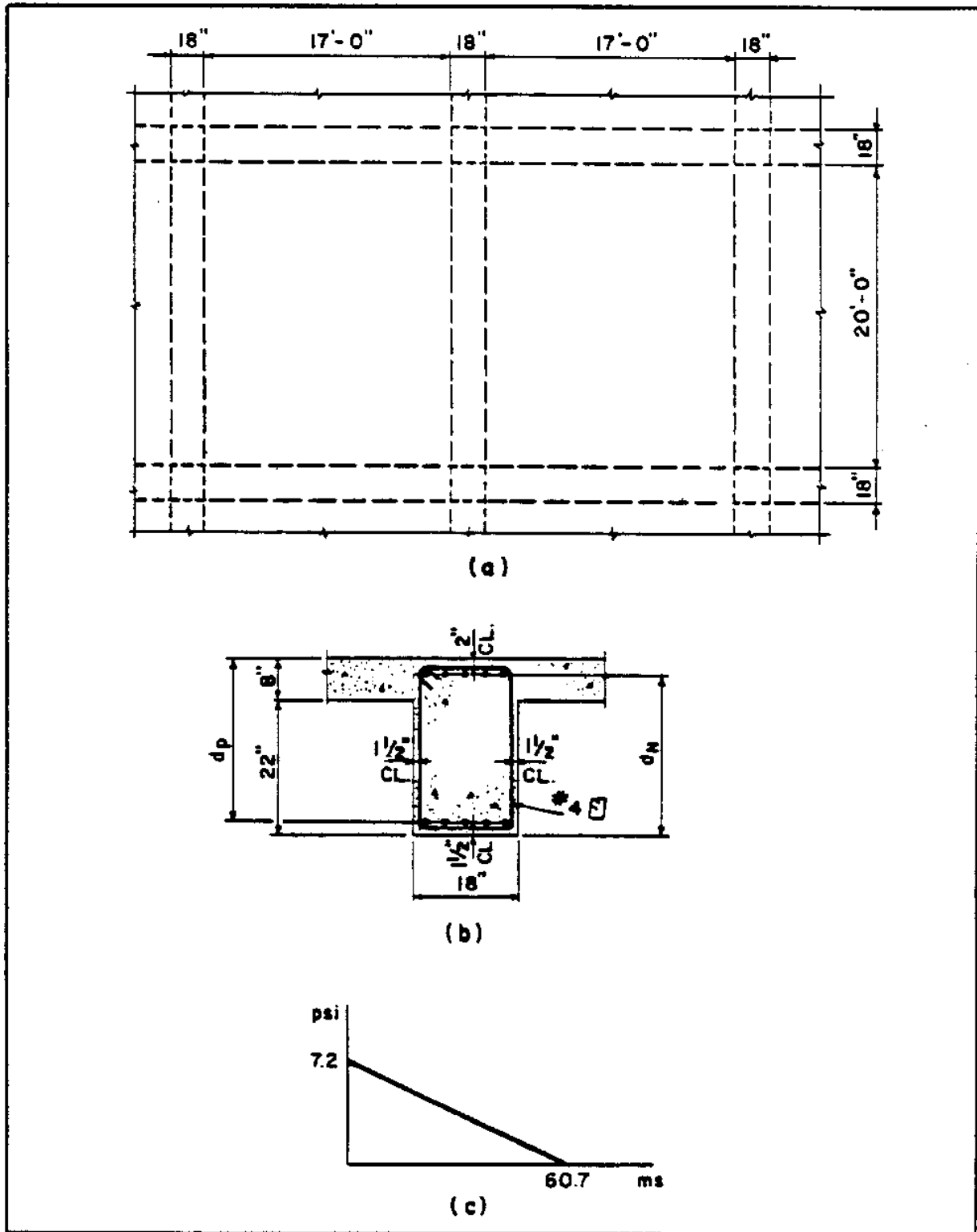

FIGURE 38
Design of Beam in Flexure

Solution:

- (1) Dynamic strength of materials from Table 5-3 03 NAVFAC P-397 for intermediate and low pressure range.

Reinforcing steel - bending, DIF = 1.10

Concrete - compression, DIF = 1.25
 - direct shear, DIF = 1.10

Using Equations (32) and (33):

Reinforcing steel - bending $f_{ry} = 1.1 \times 60,000$
 $= 66,000$ psi

Concrete - compression $f'_{rc} = 1.25 \times 4,000$
 $= 5,000$ psi

- direct shear $f'_{rd} = 1.10 \times 4,000$
 $= 4,400$ psi

- (2) Assume 5 No. 6 bars for bending:

$$A_{rs} = 5 \times .44 \\ = 2.20 \text{ in}^2$$

For concrete cover and beam sections see Figure 38b.

- (3) Calculate d negative (support) and positive (mid-span) for checking bending reinforcement ratios.

$$d = h - d' \text{ (cover)} - [\phi]' \text{ (tie)} - \frac{[\phi]}{2} \text{ (Bending Bar)}$$

$$d_N = 30 - 2 - 0.5 - 0.75/2 \\ = 27.125 \text{ in}$$

$$d_P = 30 - 1.5 - 0.5 - 0.75/2 \\ = 27.625 \text{ in}$$

From Equation (36);

$$p = A_{rs} / bd$$

$$p_N = 2.2 / (18 \times 27.125) \\ = 0.0045$$

$$p_P = 2.2 / (18 \times 27.615) \\ = 0.0044$$

Maximum reinforcing ratio $p_{max} = 0.75 \times p_{L'} / \rho_b$

From Equation (37);

$$P_{rb} = \frac{0.85K_{r1} f'_{rc} \quad 87,000}{f_{ry} \quad 87,000 + f_{ry}}$$

$$\begin{aligned} \text{where } K_{r1} &= 0.85 - \frac{0.05 (f'_{rc} - 4,000)}{1,000} \\ &= 0.80 \end{aligned}$$

$$\begin{aligned} P_{rb} &= \frac{0.85 \times 0.8 \times 5,000}{66,000} \left(\frac{87,000}{87,000 + 66,000} \right) \\ &= 0.0293 \end{aligned}$$

$$\begin{aligned} P_{max} &= 0.75 \times 0.0293 \\ &= 0.0220 > P_N = 0.0045 \text{ and } p_{rp} = 0.0044 \text{ O.K.} \end{aligned}$$

Check for minimum reinforcing ratio using Equation (42).

$$\begin{aligned} P_{min} &= \frac{200}{\frac{f_{ry}}{200}} \\ &= \frac{200}{60,000} \\ &= 0.0033 < p_{rN} = 0.0045 \text{ and } p_{rp} = 0.0044 \\ &\text{O.K.} \end{aligned}$$

(4) Moment capacity of the beam using Equations (34) and (35):

$$M_{u1} = A_{rs} f_{ry} (d - a/2)$$

where

$$\begin{aligned} a &= \frac{A_{rs} f_{ry}}{0.85b f'_{rc}} \\ &= \frac{2.20 \times 66,000}{0.85 \times 18 \times 5,000} \\ &= 1.898 \text{ in} \end{aligned}$$

at support,

$$\begin{aligned} M_{rN} &= 2.20 \times 66,000 \times (27.125 - 1.898/2) \\ &= 3,800,755 \text{ in-lb} \end{aligned}$$

at mid-span

$$\begin{aligned} M_{rp} &= 2.20 \times 66,000 \times (27.625 - 1.898/2) \\ &= 3,873,355 \text{ in-lb} \end{aligned}$$

<CO> From Table 5, ultimate resistance of a uniformly loaded beam with fixed ends is:

$$\begin{aligned} r_{\text{U}} &= \frac{8 (M_{\text{N}} + M_{\text{P}})}{L^2} \\ &= \frac{8 (3,800,755 + 3,873,355)}{240^2} \\ &= 1,065.85 \text{ lb/in} \end{aligned}$$

(6) From Chapter 5, Section II of NAVFAC P-397, calculate average moment of inertia of the beam section.

Concrete modulus of elasticity;

$$\begin{aligned} E_{\text{C}} &= w^{1.5} \times 33 \times (f'_{\text{C}})^{1/2} \\ &= 150^{1.5} \times 33 \times (4,000)^{1/2} \\ &= 3.8 \times 10^6 \text{ psi} \end{aligned}$$

Steel modulus of elasticity;

$$E_{\text{S}} = 29 \times 10^6 \text{ psi}$$

Modular Ratio;

$$\begin{aligned} n &= \frac{E_{\text{S}}}{E_{\text{C}}} \\ &= \frac{29 \times 10^6}{3.8 \times 10^6} \\ &= 7.6 \end{aligned}$$

From Figure 5-5 of NAVFAC P-397 and having n , p_{N} , and p_{P} , the coefficients for moment of inertia of cracked sections are:

$$F_{\text{N}} = 0.0235 \text{ at support}$$

$$F_{\text{P}} = 0.0230 \text{ at mid-span}$$

Cracked moment of inertia from Equation 5-22 of NAVFAC P-397 is:

$$\begin{aligned} I_{\text{C}} &= Fbd^3 \\ I_{\text{CN}} &= 0.0235 \times 18 \times 27.125^3 \\ &= 8,442 \text{ in}^4 \\ I_{\text{CP}} &= 0.0230 \times 18 \times 27.625^3 \\ &= 8,728 \text{ in}^4 \end{aligned}$$

Averaging the two values:

$$\begin{aligned} I_{rc} &= \frac{I_{rcN} + I_{rcP}}{2} \\ &= \frac{8,442 + 8,728}{2} \\ &= 8,585 \text{ in}^4 \end{aligned}$$

Gross moment of inertia:

$$\begin{aligned} I_{rg} &= \frac{bh^3}{12} \\ &= \frac{18 \times 30^3}{12} \\ &= 40,500 \text{ in}^4 \end{aligned}$$

Average moment of inertia of the beams from Equation 5-20 of NAVFAC P-397:

$$\begin{aligned} I_{ra} &= \frac{I_{rg} + I_{rc}}{2} \\ &= \frac{40,500 + 8,585}{2} \\ &= 24,542 \text{ in}^4 \end{aligned}$$

- (7) From Table 7, K_{rE} of a uniformly loaded beam with fixed ends is:

$$\begin{aligned} K_{rE} &= \frac{307 E_{rc} I_{ra}}{L^4} \\ &= \frac{307 \times 3.8 \times 10^6 \times 24,542.5}{240^4} \\ &= 8,629.70 \text{ lb/in/in} \end{aligned}$$

- (8) Equivalent elastic deflection is:

$$\begin{aligned} X_{rE} &= \frac{r_u}{K_{rE}} \\ &= \frac{1,065.85}{8,629.70} \\ &= 0.1235 \text{ in} \end{aligned}$$

- (9) Load-mass factor from Table 10 for a plastic range of a uniformly loaded beam with fixed ends is:

$$\begin{aligned} K_{rLM} &- \text{elastic} = 0.77 \\ &- \text{elasto-plastic} = 0.78 \\ &- \text{plastic} = 0.66 \end{aligned}$$

K_{rLM} for plastic mode deflections; from paragraph 7.6(1)(c) of Section 1.

$$\begin{aligned} K_{rLM} &= \left[\left(\frac{0.77 + 0.78}{2} \right) + 0.66 \right] / 2 \\ &= 0.72 \end{aligned}$$

- (10) Natural period of the beam from Equation 6-15 of NAVFAC P-397 is:

$$T_{rN} = 2[\pi] (K_{rLM} m / K_{rE})^{1/2}$$

Where m is the mass of the beam plus 20 percent of the slab's span perpendicular to the beam:

$$\begin{aligned} m &= w/g \\ &= (30 \times 18 + 2 \times 8 \times 102 \times 0.20) \times \frac{150}{12} \times \frac{1,000}{32.2 \times 12} \\ &= 194,638.50 \text{ lb-ms}^2 / \text{in}^2 \end{aligned}$$

$$\begin{aligned} T_{rN} &= 2[\pi] \left(\frac{0.72 \times 194,638.5}{8,629.70} \right)^{1/2} \\ &= 25.3 \text{ ms} \end{aligned}$$

- (11) Find X_{rM} / X_{rE} , ductility ratio from Figure 6-7 of NAVFAC P-397. From Figures 38b and 38c:

$$T / T_{rN} = 60.7 / 25.3 = 2.40$$

$$\begin{aligned} B &= (18 + 2 \times 102) \times 7.2 \\ &= 1,598.40 \text{ lb/in} \end{aligned}$$

$$\begin{aligned} B / r_{u} &= \frac{1,598.40}{1,065.85} \\ &= 1.50 \end{aligned}$$

$$X_{rM} / X_{rE} = 17.0$$

- (12) From Table 8 support rotation is:

$$X_{rM} = \frac{L \tan[\theta]}{2}$$

$$\begin{aligned} X_{rM} &= X_{rM} / X_{rE} \times X_{rE} \\ &= 17.0 \times 0.1235 \\ &= 2.10 \text{ in} \end{aligned}$$

$$\tan [\theta] = \frac{2 \times 2.10}{240} = 0.0175$$

$$[\theta] = 1.0[\text{deg.}] < \neq 1[\text{deg.}] \quad \text{O.K.}$$

(13) Direct shear from Table 9 is:

$$\begin{aligned} V_{\Gamma S \Gamma} &= \frac{r_{\Gamma u \Gamma} L}{2} \\ &= \frac{1,065.85 \times 240}{2} \\ &= 127,902 \text{ lb} \end{aligned}$$

Section capacity in direct shear from Equation (46):

$$\begin{aligned} V_{\Gamma d \Gamma} &= 0.18 f'_{\Gamma c \Gamma} b d \\ &= 0.18 \times 4,400 \times 18 \times 27.125 \\ &= 386,694 \text{ lbs} > V_{\Gamma S \Gamma} = 127,902 \quad \text{O.K.} \end{aligned}$$

(14) Diagonal tension stress from Equation (43):

$$v_{\Gamma u \Gamma} = \frac{V_{\Gamma u \Gamma}}{b d} < \neq 10[\phi] (f'_{\Gamma c \Gamma})^{1/2}$$

Total shear d distance from the face of support:

$$\begin{aligned} V_{\Gamma u \Gamma} &= (L/2 - d) r_{\Gamma u \Gamma} \\ &= \left(\frac{240}{2} - 27.125 \right) 1,065.85 \\ &= 98,990 \text{ lb} \end{aligned}$$

$$\begin{aligned} v_{\Gamma u \Gamma} &= \frac{98,990}{18 \times 27.125} \\ &= 202.7 \text{ psi} \end{aligned}$$

$$\begin{aligned} 10 [\phi] (f'_{\Gamma c \Gamma})^{1/2} &= 10 \times 0.85 \times (4,000)^{1/2} \\ &= 537.6 \text{ psi} > 202.7 \text{ psi} \quad \text{O.K.} \end{aligned}$$

(15) Unreinforced web shear capacity using Equation (45) is:

$$\begin{aligned} v_{\Gamma c \Gamma} &= [\phi] [1.9 (f'_{\Gamma c \Gamma})^{1/2} + 2,500 p] \\ &= 0.85 [1.9 (4,000)^{1/2} + 2,500 \times 0.0045] \\ &= 111.7 \text{ psi} \end{aligned}$$

$$\begin{aligned} 2.28 [\phi] (f'_{\Gamma c \Gamma})^{1/2} &= 2.28 \times 0.85 \times (4,000)^{1/2} \\ &= 122.6 \text{ psi} \geq 111.7 \text{ psi} \quad \text{O.K.} \end{aligned}$$

(16) Area of web reinforcing from Equation (45):

$$A_{\Gamma v \Gamma} = [(v_{\Gamma u \Gamma} - v_{\Gamma c \Gamma}) \times b \times s_{\Gamma s \Gamma}] / [\phi] f_{\Gamma y \Gamma}$$

Check that $v_{ru} - v_{rc} \geq v_{rc}$

$$\begin{aligned} v_{ru} - v_{rc} &= 202.7 - 111.7 \\ &= 91 < v_{rc}, \text{ therefore use } v_{rc} \end{aligned}$$

Assume $s_{rs} = 10$ in

$$\begin{aligned} A_{rv} &= 111.7 \times 18 \times 10 / (0.85 \times 60,000) \\ &= 0.394 \text{ in}^2 \end{aligned}$$

Use No. 4 tie $A_{rv} = 0.40 \text{ in}^2$

(17) Minimum tie reinforcing area:

$$\begin{aligned} A_{rv} \text{ (min)} &= 0.0015 b s_{rs} \\ &= 0.0015 \times 18 \times 10 \\ &= 0.27 \text{ in}^2 < 0.40 \text{ in}^2 \quad \text{O.K.} \end{aligned}$$

Maximum tie spacing:

$$\begin{aligned} 4 [\phi] (f'_{rc})^{1/2} &= 4 \times 0.85 \times (4,000)^{1/2} \\ &= 215 \text{ psi} > v_{rc} = 111.7 > v_{ru} - v_{rc} = 91.0 \\ &\quad \text{psi} \end{aligned}$$

$$s_{rmax} = d/2$$

$$\begin{aligned} &= \frac{27.125}{2} \\ &= 13.56 \text{ in} > 10 \text{ in} \quad \text{O.K.} \end{aligned}$$

(18) Determine required resistance for rebound, r^L , from Figure 6-8 of NAVFAC P-397.

$$r^L / r_{ru} = 0.75 \text{ for } T/T_{rn} = 2.40 \text{ and } \frac{X_{rm}}{X_{rE}} = 17.0$$

$$\begin{aligned} \text{Required } r^L &= 0.75 \times 1,065.85 \\ &= 799.4 \text{ lb/in} \end{aligned}$$

(19) Assume $A^L_{rs} = 1.64 \text{ in}^2$, two No. 7 + one No. 6.

(20) Repeat Steps (3) to (5)

$$\begin{aligned} p^L_{rn} \text{ at support} &= 0.0034 > 200/f_{ry} \\ p^L_{rp} \text{ at mid-span} &= 0.0033 = 200/f_{ry} \\ M^L_{rn} \text{ at support} &= 2,859,500 \text{ in-lbs} \\ M^L_{rp} \text{ at midspan} &= 2,913,600 \text{ in-lbs} \\ r^L &= 801.8 \text{ lb/in} > 799.4 \text{ lb/in} \end{aligned}$$

b. Design of a Beam Subject to Torsion.

Problem: Design the beam in Example Problem a. for a uniformly distributed torsional load.

Given:

- (1) Example Problem a, L , d , and v_{tu} .
- (2) Unbalanced support shears of roof slabs.

Solution:

- (1) Determine torsional load d distance from the face of support.
- (2) Find torsional stresses using Equation (47a).
- (3) Determine shear and torsional capacity of unreinforced web from Equations (48) and (49).
- (4) Find required area of web reinforcing for shear stress using Equation (45).
- (5) Find required area of web reinforcing for torsional stress using Equation (51).
- (6) Calculate total web reinforcing.
- (7) Check minimum tie reinforcing area and maximum tie spacing.
- (8) Determine required area of longitudinal steel using Equation (54a) or (54b).
- (9) Determine distribution of bending and longitudinal steel at beam section.

Calculation:

Given:

- (1) Beam of Example Problem a., $L = 240$ in, $d = 27.125$ in, and $v_{tu} = 202.7$ psi.
- (2) Unbalanced support shear from two adjacent slabs $v_{ts} = 320$ lb/in along the edge of the beam.

Solution:

- (1) Design torsional load.

$$T_{tu} = \left(\frac{L}{2} - d \right) \times v_{ts} \times \text{arm}$$

L = 240 in, d = 27.125 in from Example Problem a, and
 arm = b/2
 = 18/2
 = 9.0 in offset from centerline of beam

$$T_{tu} = \frac{240}{2} - 27.125) \times 320 \times 9$$

$$= 267,480 \text{ in-lb}$$

(2) Determine maximum torsional stress using Equation (47a), since $h > b$.

$$v_{(t_u)_v} = \frac{3T_u}{\phi b^2 h} < \frac{12 \phi (f'_c)^{1/2}}{[1 + \frac{(1.2 \times v_u)^2}{v_{tu}}]^2}^{1/2}$$

$$= \frac{3 \times 267,480}{0.85 \times 18^2 \times 30}$$

$$= 97.1 \text{ psi}$$

$v_u = 202.7 \text{ psi}$ from Example Problem a.

$$\frac{12 \phi (f'_c)^{1/2}}{[1 + \frac{(1.2 \times v_u)^2}{v_{tu}}]^2}^{1/2} = \frac{12 \times 0.85 \times (4,000)^{1/2}}{[1 + \frac{(1.2 \times 202.7)^2}{97.1}]^2}^{1/2}$$

$$= 239.0 \text{ psi} > 97.1 \text{ O.K.}$$

(3) Use Equations (48) and (49) to find shear and torsional capacity of unreinforced web.

$$v_c = \frac{2 \phi (f'_c)^{1/2}}{[1 + \frac{v_{tu}}{1.2 \times v_u}]^2}^{1/2}$$

$$= \frac{2 \times 0.85 \times (4,000)^{1/2}}{[1 + \frac{97.1}{1.2 \times 202.7}]^2}^{1/2}$$

$$= 99.9 \text{ psi}$$

$$\begin{aligned}
 v_{tc} &= \frac{2.4 \phi (f'_c)^{1/2}}{\left[1 + \frac{(1.2 v_u)^2}{v_{tu}^2}\right]^{1/2}} \\
 &= \frac{2.4 \times 0.85 \times (4,000)^{1/2}}{\left[1 + \frac{(1.2 \times 202.7)^2}{97.1^2}\right]^{1/2}} \\
 &= 47.8 \text{ psi (Vertical Face)}
 \end{aligned}$$

(4) Area of web reinforcing for shear using Equation (45).

$$A_{rv} = (v_{ru} - v_{rc}) \times b \times s / (\phi \times f_{ry})$$

Assume $s = 12$ in.

$$\begin{aligned}
 A_{rv} &= (202.7 - 99.9) \times 18 \times 12 / (0.85 \times 60,000) \\
 &= 0.435 \text{ in}^2/\text{ft}
 \end{aligned}$$

(5) Web reinforcing for torsional stress using Equation (51).

$$A_{rtv} = \frac{(v_{rtu} - v_{rtc}) b^2 h_s}{3 \phi [\alpha]_{rt} b_{rt} h_{rt} f_{ry}}$$

where,

$$[\alpha]_{rt} = 0.66 + 0.33 \frac{h_{rt}}{b_{rt}} < \leq 1.50$$

$$h_{rt} = 30.0 - 2.0 - 1.5 - 2 \times 0.5/2 = 26 \text{ in}$$

See Figure 38b.

$$b_{rt} = 18.0 - 1.5 - 1.5 - 2 \times 0.5/2 = 14.5 \text{ in}$$

See Figure 38b.

Therefore,

$$[\alpha]_{rt} = 0.66 + 0.33 \times \frac{26}{14.5} = 1.25 < 1.50 \text{ O.K.}$$

and

$$\begin{aligned} A_{rt} V_{rt} &= \frac{(97.1 - 47.8) \text{ in}^2 \times 30 \times 12}{3 \times 0.85 \times 1.25 \times 14.5 \times 26 \times 60,000} \\ &= 0.08 \text{ in}^2/\text{ft} \end{aligned}$$

2.08-117

(6) Total web reinforcement:

$$\begin{aligned} A_{fv} + A_{fv}/2 &= 0.08 + 0.435.2 \\ &= 0.298 \text{ in}^2/\text{ft/Leg} \end{aligned}$$

Use No. 4 ties at 8 in = 0.300 in²/ft/Leg

(7) Minimum tie reinforcing area:

$A_{fv}(\text{min}) = A_{fv}$ shear alone from Example Problem a.

$$\begin{aligned} &= \frac{0.394}{2} \times \frac{12}{10} \\ &= 0.236 \text{ in}^2/\text{ft/Leg} < 0.300 \text{ in}^2/\text{ft/Leg} \text{ O.K.} \end{aligned}$$

Maximum spacing:

$$\begin{aligned} s_{\text{max}} &= \frac{h_{ft} + b_{ft}}{4} \\ &= \frac{26 + 14.5}{4} \\ &= 10.125 \text{ in} > 8 \text{ in} \text{ O.K.} \end{aligned}$$

(8) Required area of longitudinal steel is the greater of the two values from Equations (54a) or (54b). Using Equation (54a):

$$\begin{aligned} A_{s1} &= 2A_{ft} \times \frac{b_{ft} + h_{ft}}{s} \\ &= 2 \times 0.08 \times \frac{14.5 + 26.0}{12} \\ &= 0.54 \text{ in}^2 \end{aligned}$$

Using Equation (54b):

$$A_{s1} = \left[\frac{1400 b s}{f_y} \left(\frac{v_{tu}}{v_{tu} + v_u} \right) - 2A_{ft} \right] \times \frac{b_{ft} + h_{ft}}{s}$$

First, check that the requirement of Equation (55) is met:

$$\begin{aligned} 2A_{\Gamma t} &= 2 \times .08 \\ &= .16 \text{ in}^2/\text{ft} \end{aligned}$$

$$\frac{50b_s}{f_{\Gamma dy}} = \frac{50 \times 18 \times 12}{66,000}$$

$$= .16 \text{ in}^2/\text{ft} < \neq .16 \text{ in}^2/\text{ft} \quad \text{O.K.}$$

Therefore,

$$A_{\Gamma^*l} = \left[\frac{400 \times 18 \times 12}{60,000} \left(\frac{97.1}{97.1 + 202.7} \right) - 0.16 \right] \times \frac{14.5 + 26.0}{12} = 1.03 \text{ in}^2$$

$$= 1.03 \text{ in}^2 > 0.54 \text{ in}^2 \quad \text{O.K.}$$

- (9) Distribute A_{Γ^*l} , $A_{\Gamma s}$, and $A_{\Gamma s}$ as follows (see Figure 39):

Distribute A_{Γ^*l} equally between four corners of the beam and one on each face of depth, a total of six locations to satisfy maximum spacing of 12 inches.

$$\begin{aligned} A_{\Gamma^*l}/6 &= 1.03/6 \\ &= 0.17 \text{ in}^2 \end{aligned}$$

Vertical Face:

$$\text{One No. 4 bar} = 0.20 \text{ in}^2 > 0.17 \quad \text{O.K.}$$

Horizontal Face at Top:

$$\begin{aligned} \text{Support} &= 2.20 \text{ (bending)} + 2 \times 0.17 \text{ (torsion)} \\ &= 2.54 \text{ in}^2 \end{aligned}$$

$$\begin{aligned} \text{Two No. 7 at corners} + \text{three No. 6} \\ &= 2.52 \text{ in}^2 \quad \text{O.K.} \end{aligned}$$

$$\text{Midspan} = 1.64 \text{ (rebound)}$$

$$\begin{aligned} \text{Two No. 7 at corners} + \text{one No. 6} \\ &= 1.64 \text{ in}^2 \quad \text{O.K.} \end{aligned}$$

Horizontal Face at Bottom:

$$\begin{aligned} \text{Support} &= \text{Greater of rebound (1.64 in}^2) \\ &\quad \text{or torsion (2 x 0.17)} \end{aligned}$$

$$\begin{aligned} \text{Two No. 7 at corners} + \text{one No. 6} \\ &= 1.64 \text{ in}^2 \quad \text{O.K.} \end{aligned}$$

$$\text{Midspan} = 2.20 \text{ (bending)}$$

$$\begin{aligned} \text{Two No. 7 at corners} + \text{one No. 6} + \text{two No. 5} \\ &= 2.26 \text{ in}^2 > 2.20 \quad \text{O.K.} \end{aligned}$$

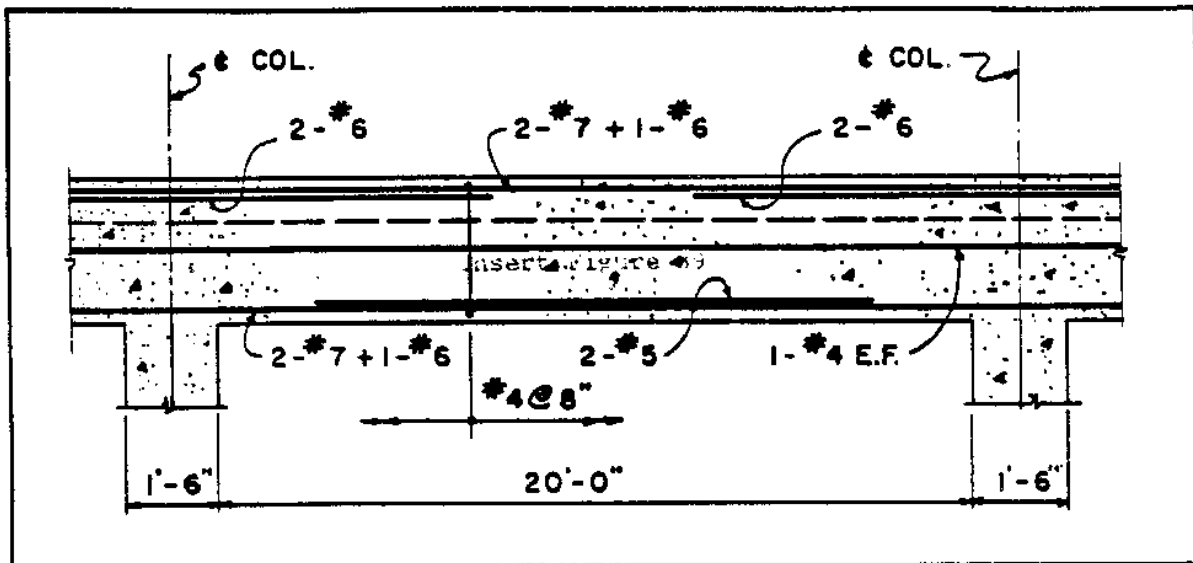

FIGURE 39
Design of Beam in Torsion

c. Design of a Column.

Problem:

Design interior column of a one-story structure with shear walls, use rectangular tied section.

Given:

- (1) Column end conditions.
- (2) Clear length of the column.
- (3) Dynamic loads from roof.
- (4) Material properties.

Solution:

- (1) Find equivalent static load.
- (2) Calculate dynamic properties of materials.
- (3) Assume column section and reinforcing steel.

- (4) Calculate slenderness ratio of the column, adjust column section to meet recommended ratio.
- (5) Find load eccentricity in both directions and compare with minimum eccentricity.
- (6) Calculate balanced eccentricity in both directions from Equation (58).
- (7) Compute axial load capacity in both directions from Equation (62) or (64).
- (8) Compute pure axial load capacity of the section from Equation (56).
- (9) Find the ultimate capacity of the column section from Equation (78).
- (10) Provide closed ties, according to paragraph 4.e.(7).

Calculation:

Given:

- (1) Both ends fixed
- (2) Column clear length, 120 in
- (3) Axial load, 530,000 lb
Moment in x-x direction, 3,180,000 in-lb
No calculated moment in y-y direction
- (4) Reinforcing steel yield stress, 60,000 psi
Compressive strength of concrete, 4,000 psi

Solution:

$$\begin{aligned}
 (1) \quad P &= \text{Axial Load} \times 1.2 \\
 &= 530,000 \times 1.2 \\
 &= 636,000 \text{ lb}
 \end{aligned}$$

$$\begin{aligned}
 M &= \text{Moment} \times 1.2 \\
 M_{\Gamma X \Gamma} &= 3,180,000 \times 1.2 \\
 &= 3,816,000 \text{ in-lb}
 \end{aligned}$$

$$M_{\Gamma Y \Gamma} = 0 \text{ in-lb}$$

$$\begin{aligned}
 (2) \quad f_{\Gamma dy \Gamma} &= f_{\Gamma y \Gamma} \times \text{DIF} \\
 &= 60,000 \times 1.10 \\
 &= 66,000 \text{ psi}
 \end{aligned}$$

$$\begin{aligned}
 f'_{\Gamma dc \Gamma} &= f'_{\Gamma c \Gamma} \times \text{DIF} \\
 &= 4,000 \times 1.25 \\
 &= 5,000 \text{ psi}
 \end{aligned}$$

- (3) Use an 18- x 18-inch column section with twelve No. 7 reinforcing bars (see Figure 40).

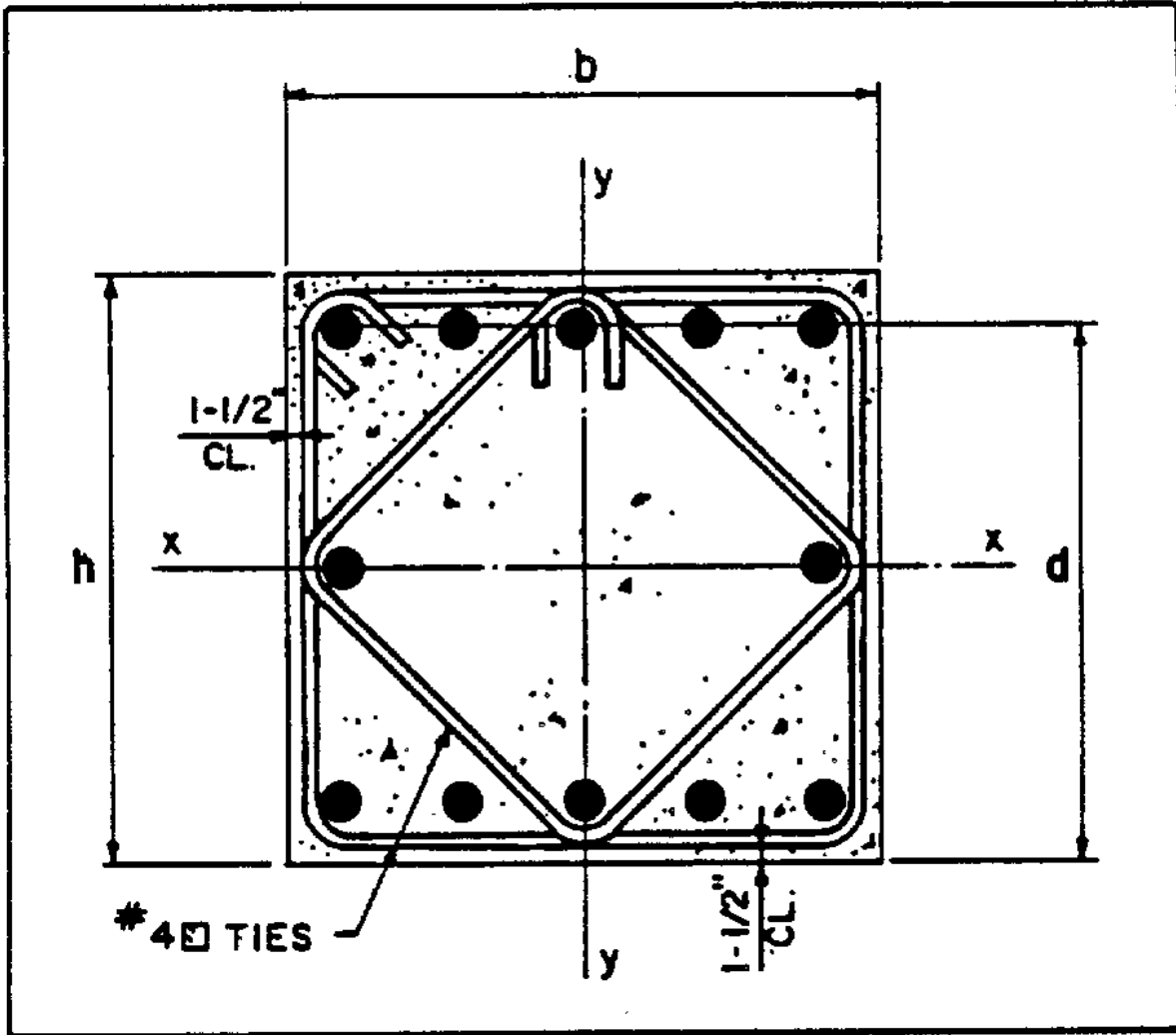

FIGURE 40
Concrete Column Section

- (4) Radius of gyration for rectangular section is equal to 0.3 of depth.

$$r_{[X]} = r_{[Y]} = 0.3 \times 18 \\ = 5.4 \text{ in}$$

From paragraph 4.c(2)(b),

$$k = 0.9$$

$$\frac{kL}{r} = \frac{0.9 \times 120}{5.4} = 20 < 22 \quad \text{O.K.}$$

- (5) Minimum eccentricity in both directions,

$$\begin{aligned}
 e_{rx} &= M_{rx} / p \\
 &= 3,816,000 / 636,000 \\
 &= 6 \text{ in} > 1.8 \text{ in}
 \end{aligned}$$

$$\begin{aligned}
 e_{ry} &= M_{ry} / P \\
 &= 0 / 636,000 \\
 &= 0 < 1.8, \text{ use } 1.8 \text{ in}
 \end{aligned}$$

(6) From Figure 40,

$$\begin{aligned}
 d_{rx} &= d_{ry} = 18 - 1.5 - 0.5 - 0.875/2 \\
 &= 15.56 \text{ in}
 \end{aligned}$$

$$\begin{aligned}
 A_{rsx} &= 4 \times 0.6 \\
 &= 2.40 \text{ in}^2
 \end{aligned}$$

$$\begin{aligned}
 A_{rsy} &= 2 \times 0.6 \\
 &= 1.20 \text{ in}^2
 \end{aligned}$$

Find value of m,

$$\begin{aligned}
 m &= f_{ry} / (0.85 f'_{rc}) \\
 &= 66,000 / (0.85 \times 5,000) \\
 &= 15.53
 \end{aligned}$$

Using Equation (58),

$$e_{rx} = 0.20 h + 1.54 A_{rs} m / b$$

$$\begin{aligned}
 e_{rx} &= 0.20 \times 18 + (1.54 \times 2.40 \times 15.53) / 18 \\
 &= 6.79 \text{ in} > 6 \text{ in, use Equation (62)}
 \end{aligned}$$

$$\begin{aligned}
 e_{ry} &= 0.20 \times 18 + (1.54 \times 1.2 \times 15.53) / 18 \\
 &= 5.19 \text{ in} > 1.8 \text{ in, use Equation (62)}.
 \end{aligned}$$

(7) Axial load from Equation (62):

$$P_u = \frac{A_{rs} f_{ry}}{e / (2d - h) + 0.5} + \frac{b h f'_{rc}}{3 h e / d + 1.18}$$

$$\begin{aligned}
 P_{rx} &= \frac{2.4 \times 66,000}{6 / (2 \times 15.56 - 18) + 0.5} \\
 &\quad + \frac{18 \times 18 \times 5,000}{3 \times 18 \times 6 / (15.56) + 1.18} \\
 &= 808,775 \text{ lb}
 \end{aligned}$$

$$\begin{aligned}
 P_{ry} &= \frac{1.2 \times 66,000}{1.8 / (2 \times 15.56 - 18) + 0.5} \\
 &\quad + \frac{18 \times 18 \times 5,000}{3 \times 18 \times 1.8 / (15.56) + 1.18} \\
 &= 1,148,662 \text{ lb}
 \end{aligned}$$

(8) Compute pure axial load capacity from Equation (56).

$$P_{\Gamma O\Gamma} = 0.85 f'_{\Gamma dc\Gamma} (A_{\Gamma g\Gamma} - A_{\Gamma st\Gamma}) + A_{\Gamma st\Gamma} f_{\Gamma dy\Gamma}$$

$$\begin{aligned} \text{where } A_{\Gamma g\Gamma} &= 18 \times 18 \\ &= 324 \text{ in}^2 \text{ and} \end{aligned}$$

$$\begin{aligned} A_{\Gamma st\Gamma} &= 12 \times 0.6 \\ &= 7.2 \text{ in}^2 \end{aligned}$$

Therefore,

$$\begin{aligned} P_{\Gamma O\Gamma} &= 0.85 \times 5,000 (324 - 7.2) + 7.2 \times 66,000 \\ &= 1,821,600 \text{ lb} \end{aligned}$$

(9) Ultimate capacity of the column from Equation (78):

$$\begin{aligned} \frac{1}{P_{\Gamma u\Gamma}} &= \frac{1}{P_{\Gamma x\Gamma}} + \frac{1}{P_{\Gamma y\Gamma}} - \frac{1}{P_{\Gamma O\Gamma}} \\ &= \frac{1}{808,775} + \frac{1}{1,148,662} - \frac{1}{1,821,600} = \frac{1}{641,830} \text{ 1/lbs} \\ &= \frac{1}{641,830} \text{ 1/lb} \end{aligned}$$

$$P_{\Gamma u\Gamma} = 641,830 \text{ lbs} > 636,000 \text{ O.K.}$$

(10) Provide ties.

For No. 7 longitudinal bars use No. 3 ties.

$$\begin{aligned} s < / = 16 | \text{ (longitudinal bars)} &= 16 \times 0.875 \\ &= 14 \text{ in} \end{aligned}$$

$$\begin{aligned} \text{and } s < / = 48 | \text{ (ties)} &= 48 \times 0.375 \\ &= 18 \text{ in} \end{aligned}$$

$$\text{and } s < / = h/2 = 9 \text{ in}$$

Use two No. 3 ties at 9 inches arranged as shown in Figure 40.

7. NOTATION.

a - Depth of equivalent rectangular stress block, in

$A_{\Gamma g\Gamma}$ - Gross area of section, in²

$A_{\Gamma^*l\Gamma}$ - Area of longitudinal torsion reinforcement, in²

$A_{\Gamma s\Gamma}$ - Total area of tension reinforcement, in²

$A'_{\Gamma s\Gamma}$ - Total area of compression reinforcement, in²

$A_{\Gamma st\Gamma}$ - Total area of uniformly distributed longitudinal reinforcement, in²

- $A_{\Gamma sp\gamma}$ - Area of spiral reinforcement, in²
- $A_{\Gamma t\gamma}$ - Area of one leg of a closed stirrup resisting torsion within a distance s , in²
- $A_{\Gamma(t)H\gamma}$ - Required area of the horizontal leg of a closed tie resisting torsion, in²
- $A_{\Gamma(t)V\gamma}$ - Required area of the vertical leg of a closed tie resisting torsion, in²
- $A_{\Gamma v\gamma}$ - Total area of stirrups resisting shear, in²
- b - Width of the beam, in
- $b_{\Gamma t\gamma}$ - Center-to-center dimension of a closed rectangular tie along b , in
- B - Peak pressure of dynamic loading, psi
- $C_{\Gamma m\gamma}$ - Equivalent moment correction
- d - Distance from extreme compression fiber to centroid of tension reinforcement, in
- d' - Distance from extreme compression fiber to centroid of compression reinforcement, in
- D - Overall diameter of circular section, in
- $D_{\Gamma S\gamma}$ - Diameter of the circle through centers of reinforcement arranged in a circular pattern, in
- $D_{\Gamma sp\gamma}$ - Diameter of the spiral measured through the centerline of the spiral bar, in
- DIF - Dynamic increase factor
- e - Actual eccentricity of applied load, in
- e' - Eccentricity of axial load at end of member measured from the centroid of the tension reinforcement, in
- $e_{\Gamma b\gamma}$ - Balanced eccentricity, in
- $e_{\Gamma min\gamma}$ - Minimum design eccentricity, in
- $e_{\Gamma x\gamma}$ - Eccentricity of axial load causing a moment about the x-axis, in
- $e_{\Gamma y\gamma}$ - Eccentricity of axial load causing a moment about the y-axis, in
- E - Modulus of elasticity, psi
- $E_{\Gamma c\gamma}$ - Modulus of elasticity of concrete, psi

- f'_{rc} - Static ultimate compressive strength of concrete, psi
 f'_{rdc} - Dynamic ultimate compressive strength of concrete, psi
 f_{rdy} - Dynamic yield stress of steel reinforcement, psi
 f_{ry} - Static yield stress of steel reinforcement, psi
 F - Coefficient for moment of inertia of cracked section
 h - Overall depth of beam, in
 h_{rt} - Center-to-center dimension of a closed rectangular tie along h , in
 I - Moment of inertia, in⁴
 I_a - Average moment of inertia of section, in⁴
 I_{rc} - Moment of inertia of cracked concrete section with equal reinforcement in opposite faces, in⁴
 I_{rg} - Moment of inertia of gross concrete section about centroidal axis, neglecting reinforcement, in⁴
 k - Effective length factor
 K_{rE} - Equivalent elastic stiffness, psi
 K_{r1} - A factor equal to 0.85 for f'_{rdc} up to 4,000 psi and is reduced by 0.05 for each 1,000 psi in excess of 4,000 psi
 L_{ru} - Unsupported length of column, in
 m - Ratio of steel design strength to concrete design strength
 M - Design moment, in-lb
 M_b - Balanced moment, in-lb
 M_n - Ultimate negative moment capacity, in-lb
 M_o - Moment capacity of the column in the absence of any axial loads, in-lb
 M_p - Ultimate positive moment capacity, in-lb
 M_u - Ultimate moment capacity, in-lb
 M_1 - Value of smaller end moment on column; positive if member is bent in single curvature and negative if bent in double curvature, in-lb
 M_2 - Value of larger end moment on column, in-lb
 p - Reinforcement ratio

p'	-	Compression reinforcement ratio
p_b	-	Balanced reinforcement ratio
$p_{\Gamma t}$	-	Total reinforcement ratio
P	-	Design axial load, lb
$P_{\Gamma b}$	-	Axial load at balanced condition, lb
$P_{\Gamma c}$	-	Critical axial load causing buckling, lb
$P_{\Gamma o}$	-	Ultimate axial load for concentrically loaded column, lb
$P_{\Gamma u}$	-	Ultimate load for biaxial bending, lb
$P_{\Gamma x}$	-	Ultimate axial load with bending about the x-axis only, lb
$P_{\Gamma y}$	-	Ultimate axial load with bending about the y-axis only, lb
r	-	Radius of gyration of column, in
$r_{\Gamma u}$	-	Ultimate unit resistance, lb/in
$R_{\Gamma u}$	-	Total ultimate resistance, lb
s	-	Spacing of torsion reinforcement in a direction parallel to the longitudinal reinforcement, in
	-	Pitch of spiral, in
$s_{\Gamma s}$	-	Spacing of shear reinforcement in the direction parallel to the longitudinal reinforcement, in
$t_{\Gamma m}$	-	Time to maximum deflection, ms
T	-	Duration of dynamic loading, ms
$T_{\Gamma N}$	-	Natural period of vibration, ms
$T_{\Gamma u}$	-	Torsional moment at critical section, in-lb
$v_{\Gamma c}$	-	Maximum shear capacity of an unreinforced web, psi
$v_{\Gamma tc}$	-	Maximum torsion capacity of an unreinforced web, psi
$v_{\Gamma tu}$	-	Nominal torsion stress in the direction of $v_{\Gamma u}$, psi
$v_{\Gamma (tu)H}$	-	Nominal torsional stress in the horizontal direction, psi
$v_{\Gamma (tu)V}$	-	Nominal torsional stress in the vertical direction, psi
$v_{\Gamma u}$	-	Nominal shear stress, psi

V_{rd} - Ultimate direct shear force, lb

V_{ru} - Total shear at critical section, lb

X_{rE} - Equivalent elastic deflection, in

X_{rm} - Maximum deflection, in

$[\alpha]_r$ - Torsion coefficient defined in Paragraph 3.f.(7)

$[\delta]$ - Moment magnifier

$[\phi]$ - Capacity reduction factor

$[\theta]$ - Support rotation, degrees

SECTION 4. STEEL STRUCTURES

1. SCOPE AND RELATED CRITERIA.

a. Scope. Criteria and data resulting from experience which will assist the Engineer in achieving cost-effective design of steel structures are presented in this section.

b. Related Criteria. The provisions for inelastic blast resistant design of steel elements and structures are consistent with conventional static plastic design procedures as presented in the AISC Specification for the Design, Fabrication and Erection of Structural Steel for Buildings, and are modified as required to account for blast loading resulting from high explosive detonations. The bulk of the information provided in this section was obtained from the report by Healey, et al., Design of Steel Structures to Resist the Effects of HE Explosions. The deformation criteria for both hot-rolled and cold-formed structural elements are summarized below:

(1) Beam elements including purlins, spandrels, and girts.

(a) Reusable structures.

$[\theta]_{\max} = 1[\text{deg.}]$ or $[\mu]_{\max} = 3$, whichever governs

(b) Non-reusable structures.

$[\theta]_{\max} = 2[\text{deg.}]$ or $[\mu]_{\max} = 6$, whichever governs

(2) Frame structures.

(a) Reusable structures.

For sidesway, maximum $[\delta]/H = 1/50$

For individual frame members, $[\theta]_{\max} = 1[\text{deg.}]$

Note: For $F_y = 36$ ksi, $[\theta]_{\max}$ should be reduced according to the following relationship for L/d less than 13.

$[\theta]_{\max} = 0.07 L/d + 0.09$

For higher yield strength, $[\theta]_{\max} = 1[\text{deg.}]$ governs over the practical range of L/d values.

(b) Non-reusable structures.

For sidesway, maximum $[\delta]/H = 1/25$

For individual frame members, $[\theta]_{\max} = 2[\text{deg.}]$

Note: For $F_y = 36$ ksi, θ_{max} should be reduced according to the following relationship for L/d less than 13:

$$\theta_{max} = 0.14 L/d + 0.18$$

For the higher yield steels, $\theta_{max} = 2$ [deg.] governs over the practical range of L/d values.

(3) Plates.

(a) Reusable structures.

$$\theta_{max} = 2 \text{ [deg.]} \text{ or } \mu_{max} = 5, \text{ whichever governs}$$

(b) Non-reusable structures.

$$\theta_{max} = 4 \text{ [deg.]} \text{ or } \mu_{max} = 10, \text{ whichever governs}$$

(4) Cold-Formed Panels.

(a) Reusable structures.

$$\theta_{max} = 2 \text{ [deg.]} \text{ or } \mu_{max} = 3.0, \text{ whichever governs}$$

(b) Non-reusable structures.

$$\theta_{max} = 4 \text{ [deg.]} \text{ or } \mu_{max} = 6.0, \text{ whichever governs}$$

(5) Open-Web Joists.

(a) Reusable structures.

$$\theta_{max} = 1 \text{ [deg.]} \text{ or } \mu_{max} = 2, \text{ whichever governs}$$

(b) Non-reusable structures.

$$\theta_{max} = 2 \text{ [deg.]} \text{ or } \mu_{max} = 4, \text{ whichever governs}$$

Note: For the equations above:

θ_{max} = maximum member end rotation (degrees)
measured from the chord joining the member ends.

Δ = relative sidesway deflection between stories

H = story height

μ_{max} = maximum ductility ratio, X_m/X_E , for an element

L/d = span/depth ratio for a beam element

2. RECOMMENDED DESIGN STRESSES.

a. Structural Steel. The yield point of steel under uniaxial tensile stress is generally used as a base to determine the yield stresses under other loading conditions. The compressive yield stress of steel, for example, is equal to F_{γ} , the yield point in tension. The shear yield stress is taken as $0.55F_{\gamma}$. To determine the plastic strength of a section under dynamic loading, the appropriate dynamic yield stress, F_{dy} , must be used. This is to be equal to the dynamic increase factor times the specified minimum yield stress of the steel. The dynamic yielding stress in shear, F_{dv} , is taken equal to $0.55F_{dy}$.

TABLE 11
Dynamic Increase Factor, c

Pressure Range	ASTM A36 - Steel	High Strength, Low Alloy Steels
Low to Intermediate	1.1	1.1
High	1.1 or a higher value determined from the actual strain rate	1.1

$$\text{EQUATION:} \quad F_{dy} = cF_{\gamma} \quad (80)$$

where,

c = dynamic increase factor
 F_{dy} = dynamic yield stress in flexure

$$\text{EQUATION:} \quad F_{dv} = 0.55F_{dy} \quad (81)$$

where,

F_{dv} = dynamic yield stress in shear.

b. Cold-Formed Steel. The material properties of the steel used in the production of light-gaged steel members conform to ASTM Specification A446 (Grades a, b, and c steel). In calculating the dynamic yield stress of cold-formed steel members in flexure, it is recommended that a dynamic increase factor of 1.1 be applied irrespective of actual strain rate. The value to be used in design should be:

EQUATION:
$$F_{rdy} = 1.1F_{ry} \quad (82)$$

The dynamic yield stresses in shear for different steels are presented in paragraph 4.b.(2) of this section.

3. BEAMS AND PLATES.

a. Beams.

(1) Dynamic Flexural Capacity. The dynamic flexural capacity of a steel section is related to its static flexural capacity by the ratio of the dynamic to the static yield stresses of the material. For beams with design ductility less than or equal to 3, and for a rectangular cross-sectional beam with any design ductility ratio:

EQUATION:
$$M_{rp} = F_{rdy} (S + Z) / 2 \quad (83)$$

where S and Z are the elastic and plastic section moduli, respectively.

For beams with design ductility ratio greater than 3:

EQUATION:
$$M_{rp} = F_{rdy} Z \quad (84)$$

(2) Resistance-Deflection Function. The resistance-deflection functions for steel beams are the same as for concrete beams and are shown in Figure 34. Formulas for determining the ultimate unit resistance and the elastic and elasto-plastic unit resistances are shown in Tables 5 and 6 respectively. The elastic, elasto-plastic, and equivalent elastic stiffnesses are shown in Table 7. For uniformly distributed loading on spans which do not differ in length by more than 20 percent, the following relationships can be used to define the resistance-deflection function.

1. Two-span continuous beam:

EQUATION:
$$r_{ru} = 12M_{rp} / L^2 \quad (85)$$

EQUATION:
$$K_{rE} = 163EI / L^4 \quad (86)$$

2. Exterior span of continuous beams with 3 or more spans:

EQUATION:
$$r_{ru} = 11.7M_{rp} / L^2 \quad (87)$$

EQUATION:
$$K_{rE} = 143EI / L^4 \quad (88)$$

3. Interior span of continuous beam with 3 or more spans:

$$\text{EQUATION:} \quad r_{\Gamma u_{\Gamma}} = 16M_{\Gamma p_{\Gamma}}/L \quad (89)$$

$$\text{EQUATION:} \quad K_{\Gamma E_{\Gamma}} = 300EI/L^4 \quad (90)$$

(3) Design for Flexure. The design of a structure to resist the blast of an accidental explosion consists essentially of the determination of the structural resistance required to limit calculated deflections to within the prescribed maximum values. In general, the resistance and deflection may be computed on the basis of flexure provided that the shear capacity of the web is not exceeded. Elastic shearing deformations of steel members are negligible as long as the depth-to-span ratio is less than about 0.2 and, hence, a flexural analysis is normally sufficient for establishing maximum deflections. For any system for which the total effective mass and equivalent stiffness are known, the natural period of vibration can be expressed as:

$$\text{EQUATION:} \quad T_{\Gamma N_{\Gamma}} = 2[\pi] (m_{\Gamma e_{\Gamma}}/K_{\Gamma E_{\Gamma}})^{1/2} \quad (91)$$

where,

$$\begin{aligned} m_{\Gamma e_{\Gamma}} &= mK_{\Gamma LM_{\Gamma}}, \text{ the total effective mass per unit length and} \\ K_{\Gamma LM_{\Gamma}} &= \text{mass factor from table 10} \\ K_{\Gamma E_{\Gamma}} &= r_{\Gamma u_{\Gamma}}/X_{\Gamma E_{\Gamma}} = \text{equivalent spring constant} \\ r_{\Gamma u_{\Gamma}} &= \text{ultimate resistance} \\ X_{\Gamma E_{\Gamma}} &= \text{equivalent elastic deflection} \end{aligned}$$

In the low and intermediate pressure ranges, it is recommended that the structure in the preliminary stage be designed to have an equivalent static ultimate resistance equal to the peak blast force for a reusable structure and 0.8 times the peak blast force for a non-reusable structure.

(4) Design for Shear. At points where large bending moments and shear forces exist, the assumption of an ideal elasto-plastic stress-strain relationship indicates that during the progressive formation of a plastic hinge, there is a reduction of the web area available to shear. This reduced area could result in an initiation of shear yielding and possibly reduce the moment capacity. The yield capacity of steel beams in shear is given by:

$$\text{EQUATION:} \quad V_{\Gamma p_{\Gamma}} = F_{\Gamma dv_{\Gamma}} A_{\Gamma w_{\Gamma}} \quad (92)$$

where,

$$\begin{aligned} V_{\Gamma p_{\Gamma}} &= \text{dynamic shear capacity} \\ F_{\Gamma dv_{\Gamma}} &= \text{dynamic shear yield strength of the steel} \\ A_{\Gamma w_{\Gamma}} &= \text{area of web} \end{aligned}$$

For I-shaped beams and similar flexural members with thin webs, only the web area between flange plates should be used in calculating A_{fw} . Table 9 gives equations for support shears, V , for beams for several particular load and support conditions.

(5) Local Buckling. To insure that a steel beam will attain fully plastic behavior and possess the assumed ductility at plastic hinge locations, the elements of the beam section must meet the minimum thickness requirements sufficient to prevent a local buckling failure. Adopting the plastic design requirements of the AISC Specification, the width-thickness ratio for flanges of rolled I- and W-shapes, and similar built-up single web shapes that would be subjected to compression involving plastic hinge rotation, shall not exceed the following values:

F_{ry} (ksi)	$b_{rf}/2t_{rf}$
36	8.5
42	8.0
45	7.4
50	7.0
55	6.6
60	6.3
65	6.0

where,

F_{ry} = specific minimum static yield stress for steel
 b_{rf} = flange width
 t_{rf} = flange thickness.

(a) The width-thickness ratio of similarly compressed flange plates in box sections and cover plates shall not exceed $190/(F_{ry})^{1/2}$. For this purpose, the width of a cover plate shall be taken as the distance between longitudinal lines of connecting rivets, high-strength bolts or welds.

(b) The depth-thickness ratio of webs subjected to plastic bending shall not exceed the value given by Equations (93a) or (93b) depending on the value of P/P_{ry} . When P/P_{ry} is less than 0.27:

$$\text{EQUATION: } d/t_{rw} = [412/(F_{ry})^{1/2}][1 - 1.4P/P_{ry}] \quad (93a)$$

When P/P_{ry} is greater than 0.27:

$$\text{EQUATION: } d/t_{rw} = 257/(F_{ry})^{1/2} \quad (93b)$$

where,

P = applied compressive load
 P_{ry} = plastic axial load equal to the cross-sectional area times the specified minimum static yield stress, F_{ry} .

(6) Web Crippling. Provisions for web stiffeners, as presented in Section 1.15.5 of the AISC Specification, should be used in dynamic design. In applying these provisions, F_{dy} should be taken equal to the specified static yield strength of the steel.

(7) Lateral Bracing. Members subjected to bending about their strong axis may be susceptible to lateral torsional buckling in the direction of the weak axis if their compression flange is not laterally braced. Therefore, in order for a plastically designed member to reach its collapse mechanism, lateral supports must be provided at the plastic hinge locations and at a certain distance from the hinge location. The distance from the brace at the hinge location to the adjacent braced points should not be greater than $*l_{cr}$ as determined from either Equation (94a) or (94b) depending on the value of M/M_p .

$$\text{EQUATION: } *l_{cr}/r_y = 1,375/F_{dy} + 25, \quad -0.5 < M/M_p < 1.0 \quad (94a)$$

$$\text{EQUATION: } *l_{cr}/r_y = 1,375/F_{dy}, \quad -1.0 < M/M_p < -0.5 \quad (94b)$$

where,

r_y = radius of gyration of the member about its weak axis
 M = lesser of the moments at the ends of the unbraced segment
 M/M_p = end moment ratio; positive when the segment is bent in reverse curvature and negative when bent in single curvature.

(a) Since the last hinge to form in the collapse mechanism is required to undergo less plastic deformation, the bracing requirements are somewhat less stringent. For this case, in order to develop the full plastic design moment, M_p , the following relationship may be used for members with design ductility ratios less than or equal to 3.

$$\text{EQUATION: } *l/r_T = [(102 \times 10^3 C_b)/F_{dy}]^{1/2} \quad (95)$$

where,

$*l$ = distance between cross sections braced against twist or lateral displacement of the compression flange
 r_T = radius of gyration of a section comprising the compression flange plus 1/3 of the compression web area taken about an axis in the plane of the web
 C_b = bending coefficient defined in Section 1.5.1.4.6a of the AISC Specification.

(b) However, in structures designed for ductility ratios greater than 3, the bracing requirements of Equation (94a) or (94b) must be met.

(c) The bracing requirements for non-yielded segments of members and the bracing requirements for members in rebound can be determined from the following relationship:

$$\text{EQUATION: } F = 1.67 \left[\frac{2}{3} - F_{ry} \left(\frac{l}{r_T} \right)^2 / (1,530 \times 10^3 C_{rb}) \right] F_{ry} \quad (96)$$

where,

F = maximum bending stress in the member and in no case greater than F_{ry} .

When $F = F_{ry}$, this equation reduces to the $\frac{l}{r_T}$ requirement of Equation (95).

b. Plates.

(1) Resistance Functions. Stiffness and resistance factors for one- and two-way plate elements are presented in Chapter 5, Sections III and IV of NAVFAC P-397. These factors, originally developed for concrete elements and based upon elastic deflection theory and the yield-line method, are also appropriate for defining the stiffness and ultimate load-carrying capacity of ductile structural steel plates.

(2) Design for Flexure. For flexural design of steel plate, use the criteria presented in paragraph 3.a.(3) for beams.

(3) Design for Shear. In the design of rectangular plates, the effect of simultaneous high moment and high shear of negative yield lines upon the plastic strength of the plate may be significant. In such cases, the following interaction formula describes the effect of the support shear, V , upon the available moment capacity, M :

$$\text{EQUATION: } M/M_{rp} = 1 - (V/V_{rp})^4 \quad (97)$$

where,

M_{rp} = fully plastic moment capacity in the absence of shear calculated by multiplying the dynamic yield stress by the plastic modulus

V_{rp} = ultimate shear capacity in the absence of bending determined from Equation (92) where the web area, A_{rw} , is taken equal to the total cross-sectional area at the support.

(a) For two-way elements, values for the ultimate support shears are presented in Chapter 5 of NAVFAC P-397. These shears may also be used for steel plates. However, the ultimate shearing stresses given in Section V for concrete elements are not applicable to steel.

(b) If the V/V_{Fp} ratio on negative yield lines is less than 0.67, the plastic design moment for plates, given by Equation (84), is:

$$M_{Fp} = F_{dy} Z$$

(c) If V/V_{Fp} is greater than 0.67, then the influence of shear on the available moment capacity must be accounted for by means of Equation (97).

4. COLD-FORMED STEEL ELEMENTS.

a. Beam Elements. Many of the design provisions made for hot-rolled shapes are equally applicable to cold-formed elements. However, the differences in behavior under load between the two types of elements are sufficiently pronounced to necessitate corresponding differences in design methods. Design procedures are presented in the Specification for the Design of Cold-Formed Steel Structural Members issued by the American Iron and Steel Institute at Part I of its Cold-Formed Steel Manual. The provisions for hot-rolled beam elements outlined in paragraph 3.a. of this section are also applicable to cold-formed elements. A dynamic increase factor of 1.1 should also be applied to the yield stress of the material.

b. Panels.

(1) Resistance in Flexure. For design purposes, the following formulas are recommended:

1. Simply-supported, single-span panel:

EQUATION:
$$r_{Fu} = 8M_{Fup} / L^2 \quad (98)$$

2. Simply-fixed, single-span panel or first span of a equally spaced continuous panel:

EQUATION:
$$r_{Fu} = 4(M_{Fun} + 2M_{Fup}) / L^2 \quad (99)$$

where,

r_{Fu} = resistance per unit area of panel
 M_{Fup} , M_{Fun} = positive and negative plastic moments per unit width, respectively.
 L = span length, ft

The equivalent elastic deflection, X_{FE} , is defined as

EQUATION:
$$X_{FE} = ([\beta] r_{Fu} L^4) / EI \quad (100)$$

where,

[beta] = constant depending on the support conditions as follows:
 for simply-supported element = 0.0130
 for simple-fixed or continuous element = 0.0062
 I = moment of inertia of the element.

(b) The extent of plastic behavior is expressed in terms of a ductility ratio:

$$\text{EQUATION:} \quad [\mu] = X_{\Gamma m \Gamma} / X_{\Gamma E \Gamma} \quad (101)$$

The following ductility ratios are recommended:

[mu] = 3.0 for reusable elements
 [mu] = 6.0 for non-reusable elements.

In order to restrict the magnitude of rotation at the supports, limitations are placed on the maximum deflections, namely:

$X_{\Gamma m \Gamma} = L/57$ or $[\theta]_{\Gamma \max \Gamma} = 2[\text{deg.}]$ for reusable elements

$X_{\Gamma m \Gamma} = L/29$ or $[\theta]_{\Gamma \max \Gamma} = 4[\text{deg.}]$ for non-reusable elements

(c) For a one degree-of-freedom analysis of a panel's behavior, the properties of the equivalent system can be evaluated by using a load-mass factor, $K_{\Gamma LM \Gamma} = 0.74$, which is an average value applicable to all support conditions. The natural period of vibration for the equivalent single-degree system is thus obtained by:

$$\text{EQUATION:} \quad T_{\Gamma N \Gamma} = 2[\pi] (0.74m / K_{\Gamma E \Gamma})^{1/2} \quad (102)$$

where,

$m = w/g$ is the unit mass of the panel and
 $K_{\Gamma E \Gamma} = r_{\Gamma u \Gamma} / X_{\Gamma E \Gamma}$ is the equivalent elastic stiffness of the system.

(d) The problem of rebound should be considered in the design of decking due to the different section properties of the panel, depending on whether the section on the flat sheet is in compression. Figure 41 shows the maximum elastic resistance in rebound as a function of $T/T_{\Gamma N \Gamma}$.

(2) Resistance in Shear. The shear capacity of the web of a cold-formed panel is dictated by instability due to either simple shear stresses or combined bending and shearing stresses.

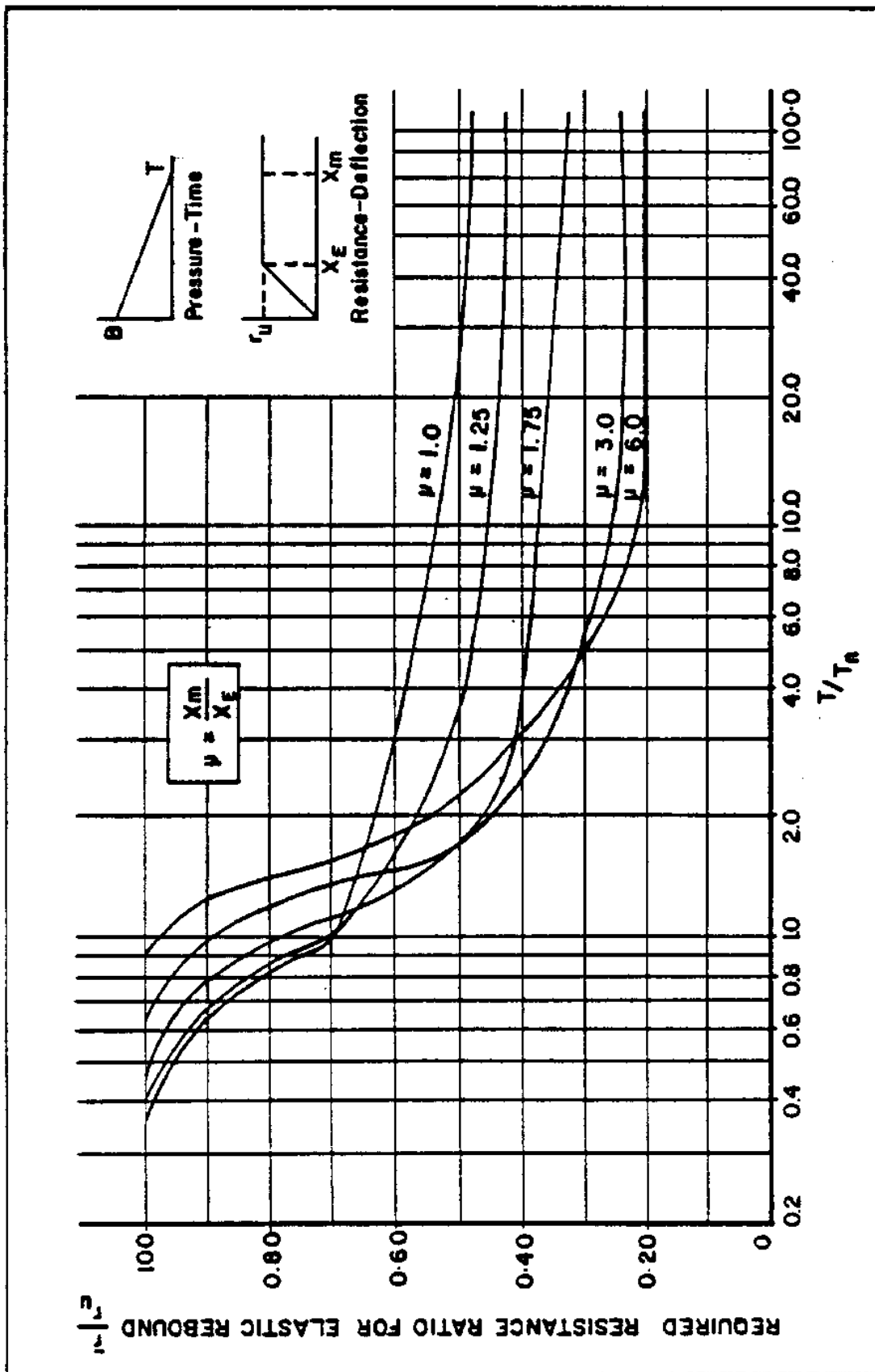

FIGURE 41
Elastic Rebound of Single-Degree-of-Freedom System

(a) For the case of simple shear stresses, as encountered at end supports, it is important to distinguish three ranges of behavior depending on the magnitude of h/t . For large values of h/t , the maximum shear stress is dictated by elastic buckling in shear, and for intermediate h/t values the inelastic buckling of the web governs; whereas for very small values of h/t , local buckling will not occur and failure will be caused by yielding produced by shear stresses. This point is illustrated in Figure 42 for $F_{ry} = 40$ ksi. The specific equations for use in design for $F_{ry} = 40$, 60, and 80 ksi are summarized in Tables 12, 13, and 14, respectively.

(b) At the interior supports of continuous panels, high shear bending moments combined with large shear forces are present and webs must be checked for buckling due to these forces. The interaction formula presented in the AISI Specification is given in terms of the allowable stresses rather than critical stresses which produce buckling. In order to adapt this interaction formula to ultimate load conditions, the problem of inelastic buckling under combined stresses has been considered in the development of the recommended design data.

(c) To minimize the amount and complexity of design calculations, the allowable design shear stresses at the interior support of a continuous member have been computed for different depth-to-thickness ratios for $F_{ry} = 40$, 60, and 80 ksi, and tabulated in Tables 12, 13, and 14.

(3) Web Crippling. In addition to shear problems, concentrated loads or reactions at panel supports, applied over relatively short lengths, can produce load intensities that can cripple unstiffened thin webs. For blast resistant design, the values recommended by AISI are multiplied by a safety factor of 1.50 to relate the crippling loads to the ultimate conditions.

(a) For those sections that provide a high degree of restraint against rotation of their webs such as I-beams made by welding two angles to a channel, the ultimate crippling loads are given as follows:

Acceptable ultimate end support reaction

$$\text{EQUATION:} \quad (Q_{ru})_e = 1.5F_{ry}t^{L/2} [4.44 + 0.558(N/t)^{L/2}] \quad (103)$$

Acceptable ultimate interior support reaction

$$\text{EQUATION:} \quad (Q_{ru})_i = 1.5F_{ry}t^{L/2} [6.66 + 1.446(N/t)^{L/2}] \quad (104)$$

where,

Q_u = ultimate support reaction
 F_{ry} = yield stress
 N = bearing length
 t = web thickness

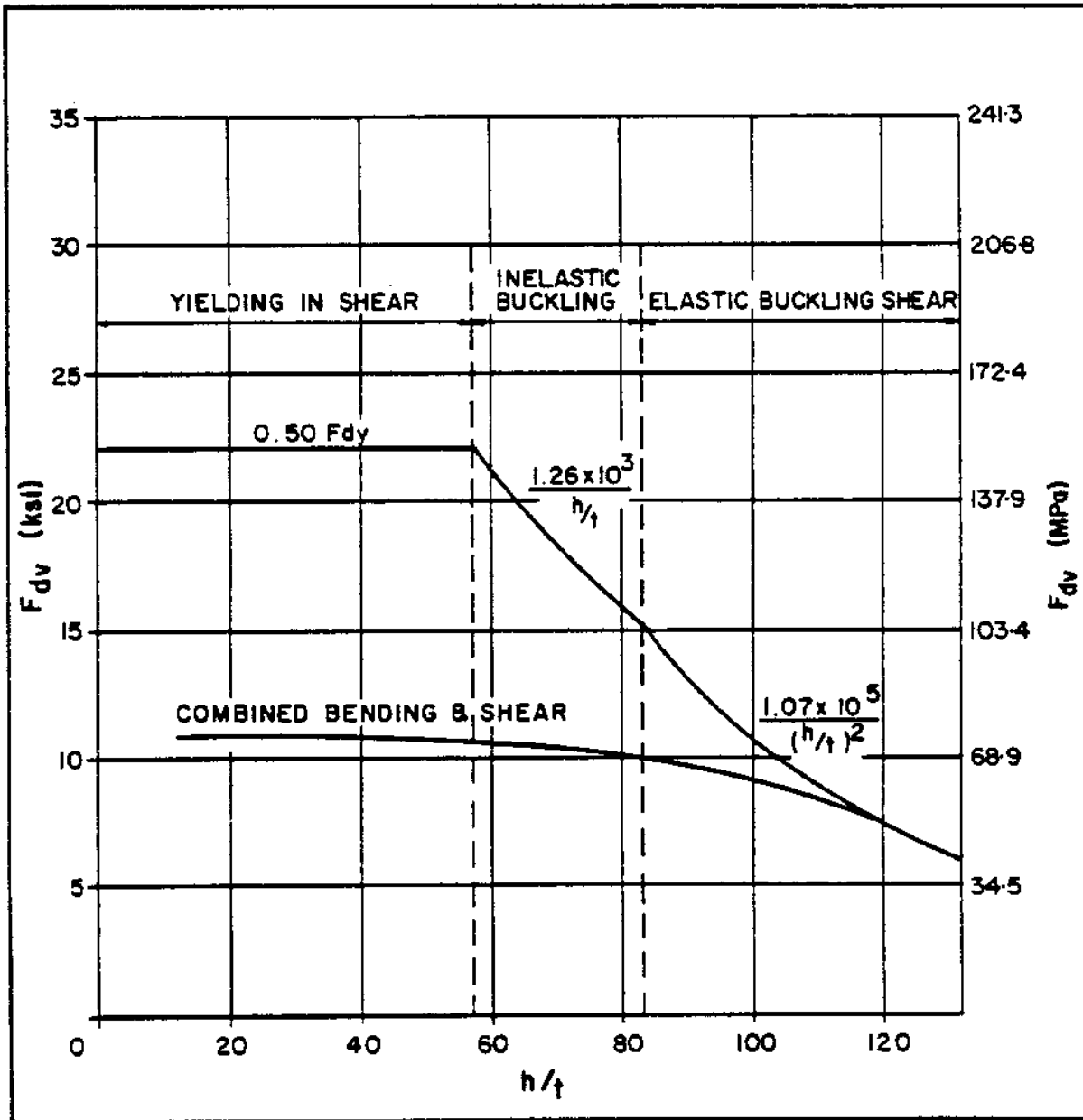

FIGURE 42

Allowable Dynamic (Design) Shear Stresses
for Webs of Cold Formed Members ($F_y=40$ ksi)

TABLE 12
 Dynamic Design Shear Stress for Webs of Cold-Formed Members
 ($F_{\gamma} = 40$ ksi)

Simple Shear		
$(h/t) \leq 57$	$F_{dv} = 0.50$	$F_{dy} \leq 22.0$ ksi
$57 < (h/t) \leq 83$	$F_{dv} = 1.26 \times 10^{-3} / (h/t)$	
$83 < (h/t) \leq 150$	$F_{dv} = 1.07 \times 10^{-5} / (h/t)$	

Combined Bending and Shear	
(h/t)	F_{dv} (ksi)
20	10.94
30	10.84
40	10.72
50	10.57
60	10.42
70	10.22
80	9.94
90	9.62
100	9.00
110	8.25
120	7.43

TABLE 13
 Dynamic Design Shear Stress for Webs of Cold-Formed Members
 ($F_{\gamma} = 60$ ksi)

Simple Shear		
$(h/t) \leq 47$	$F_{\gamma} = 0.50$	$F_{\gamma} \leq 33.0$ ksi
$47 < (h/t) \leq 67$	$F_{\gamma} = 1.54 \times 10^{-3} / (h/t)$	
$67 < (h/t) \leq 150$	$F_{\gamma} = 1.07 \times 10^{-5} / (h/t)$	

Combined Bending and Shear	
(h/t)	F_{γ} (ksi)
20	16.41
30	16.23
40	16.02
50	15.75
60	15.00
70	14.20
80	13.00
90	11.75
100	10.40
110	8.75
120	7.43

TABLE 14
 Dynamic Design Shear Stress for Webs of Cold-Formed Members
 ($F_{y1} = 80$ ksi)

Simple Shear		
$(h/t) \leq 41$	$F_{dv1} = 0.50$	$F_{dy1} \leq 44.0$ ksi
$41 < (h/t) \leq 58$	$F_{dv1} = 1.78 \times 10^{-3} / (h/t)$	
$58 < (h/t) \leq 150$	$F_{dv1} = 1.07 \times 10^{-5} / (h/t)$	

Combined Bending and Shear	
<u>(h/t)</u>	<u>F_{dv1} (ksi)</u>
20	21.60
30	21.00
40	20.00
50	18.80
60	17.50
70	16.00
80	14.30
90	12.50
100	10.75
110	8.84
120	7.43

(b) The curves in Figures 43 and 44 present the variation of Q_{ru} as a function of the web thickness for bearing lengths of 1 to 5 inches for end and interior supports, respectively. Tables 15 through 18 present the same variation of Q_{ru} for $F_{ry} = 60$ and 80 ksi. It should be noted that the values reported in the charts and tables relate to one web only, the total ultimate reaction being obtained by multiplying Q_{ru} by the number of webs in the panel.

5. COLUMNS AND BEAM COLUMNS.

a. Plastic Design Criteria. The design criteria for columns and beam columns must account for their behavior not only as individual members but also as members of the overall frame structure. Depending on the nature of the loading, several design cases may be encountered. Listed below are the necessary equations for the dynamic design of steel columns and beam columns.

(1) In the plane of bending of compression members which would develop a plastic hinge at ultimate loading, the slenderness ratio $*l/r$ shall not exceed C_{rc} defined by:

$$\text{EQUATION:} \quad C_{rc} = (2[\pi]^2 E / F_{ry})^{1/2} \quad (105)$$

where,

E = modulus of elasticity of steel, ksi
 $F_{ry} = cF_y$ = dynamic yield stress
 c = dynamic increase factor

The ultimate strength of an axially loaded compression member should be taken as:

$$\text{EQUATION:} \quad P_{ru} = 1.7AF_{ra} \quad (106)$$

where,

A = gross area of member

$$F_{ra} = \frac{[1 - (K*l/r)^2 / 2C_{rc}^2] F_{ry}}{5/3 + 3(K*l/r) / 8C_{rc} - (K*l/r)^3 / 8C_{rc}^3}$$

$K*l/r$ = largest effective slenderness ratio.

(2) Members subject to combined axial load and biaxial bending moment should be proportioned so as to satisfy the following set of interaction formulas:

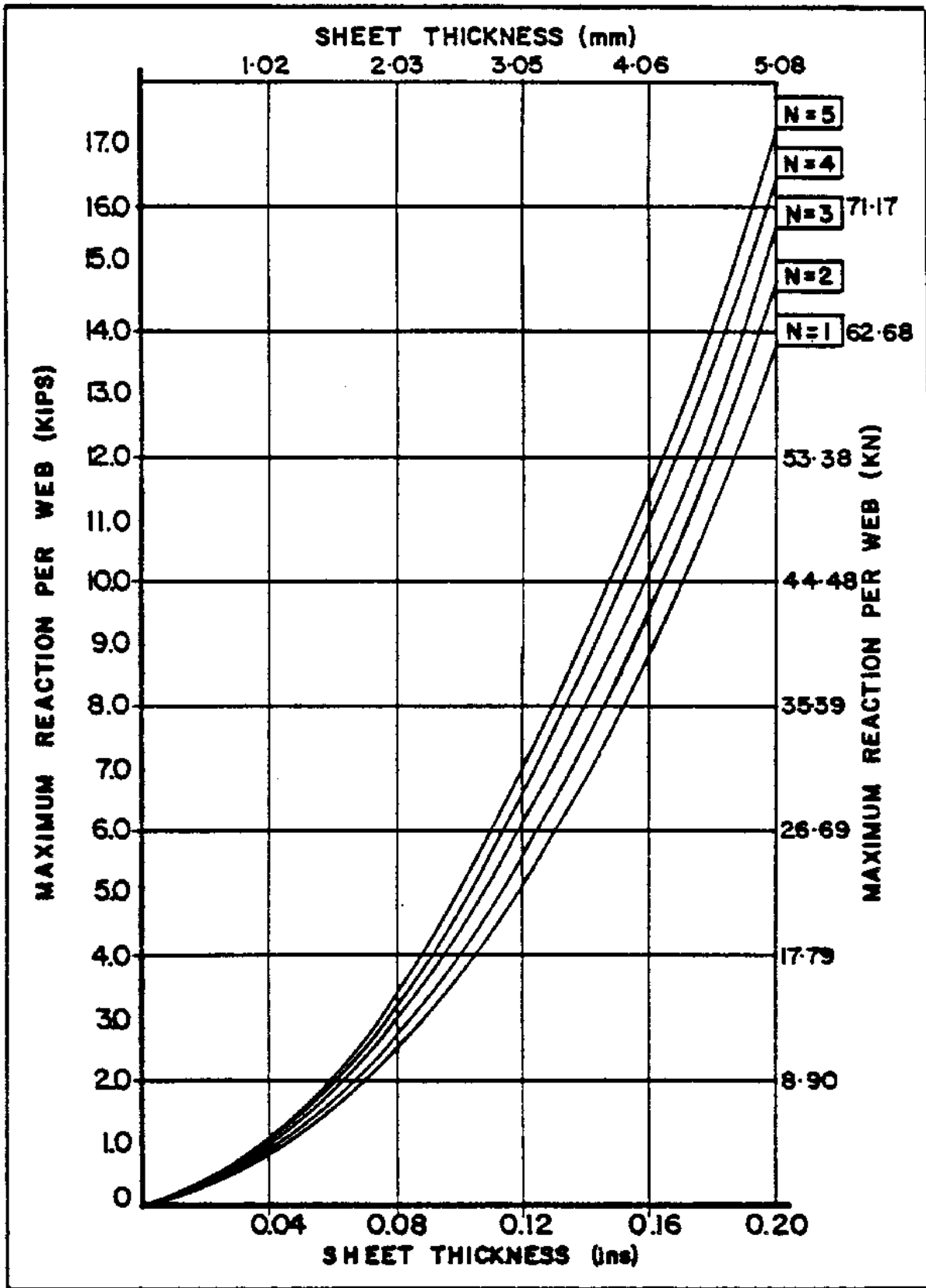

FIGURE 43
Maximum End Support Reaction for
Cold-Formed Steel Sections, $F_y = 40$ ksi (275.8 MPa)

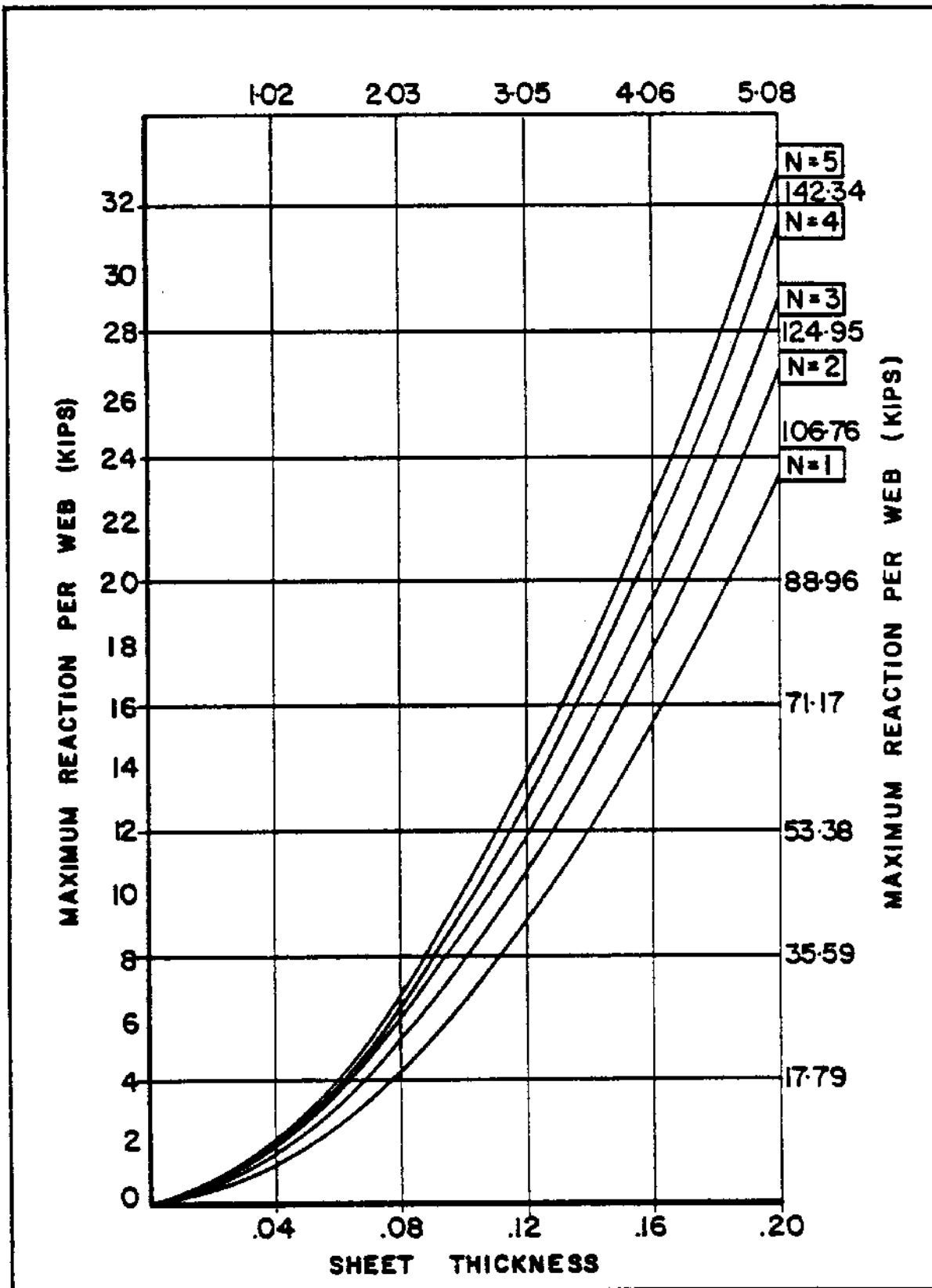

FIGURE 44
Maximum Interior Support Reaction for
Cold-Formed Steel Sections $F_y = 40$ ksi (275.8 MPa)

TABLE 15
 Maximum End Support Reaction for Cold-Formed Steel Sections
 ($F_{\gamma} = 60$ ksi)

$$Q_{\gamma} = 1.5t \sqrt{F_{\gamma}} [4.44 + 0.558(N/t) \sqrt{1/2}]$$

$$= 90t \sqrt{1/2} [4.44 + 0.558(N/t) \sqrt{1/2}] \text{ kips}$$

N = Bearing Length, in

Sheet thickness t (in)	Q_{γ} , kips				
	N = 1	N = 2	N = 3	N = 4	N = 5
.02	.30	.36	.41	.45	.48
.04	1.04	1.22	1.34	1.44	1.55
.06	2.18	2.48	2.72	2.91	3.09
.08	3.69	4.17	4.53	4.83	5.10
.10	5.58	6.24	6.75	7.17	7.55
.12	7.85	8.70	9.38	9.93	10.43
.14	10.47	11.55	12.39	13.10	13.71
.16	13.44	14.78	15.80	16.67	17.42
.18	16.79	18.32	19.59	20.61	21.53
.20	20.48	22.34	23.76	24.98	26.03

TABLE 16
 Maximum Interior Support Reaction for Cold-Formed Steel Sections
 ($F_{ry} = 60$ ksi)

$$Q_{ru} = 1.5tL_2^2 F_{ry} [6.66 + 1.446(N/t) L_1/2]$$

$$= 90tL_2^2 [6.66 + 1.446(N/t) L_1/2] \text{ kips}$$

N = Bearing Length, in

Sheet thickness t (in)	Q_{ru} , kips				
	N = 1	N = 2	N = 3	N = 4	N = 5
.02	.62	.77	.87	.98	1.07
.04	2.00	2.43	2.76	3.05	3.29
.06	4.07	4.86	5.48	5.99	6.44
.08	6.78	8.00	8.94	9.72	10.43
.10	10.11	11.82	13.13	14.22	15.20
.12	14.04	16.28	18.00	19.46	20.73
.14	18.57	21.39	23.55	25.38	26.99
.16	23.67	27.12	29.78	32.01	33.98
.18	29.36	33.48	36.63	39.30	41.64
.20	35.61	40.44	44.13	47.25	50.01

TABLE 17
 Maximum End Support Reaction for Cold-Formed Steel Sections
 ($F_{\gamma} = 80$ ksi)

$$Q_{\gamma} = 1.5tL_2F_{\gamma}[4.44 + 0.558(N/t)L_1/2]$$

$$= 120tL_2[4.44 + 0.558(N/t)L_1/2] \text{ kips}$$

N = Bearing Length, in

Sheet thickness t (in)	Q_{γ} , kips				
	N = 1	N = 2	N = 3	N = 4	N = 5
.02	.40	.48	.54	.60	.64
.04	1.38	1.62	1.78	1.92	2.06
.06	2.90	3.30	3.62	3.88	4.12
.08	4.92	5.56	6.04	6.44	6.80
.10	7.44	8.32	9.00	9.56	10.60
.12	10.46	11.60	12.50	13.24	13.95
.14	13.96	15.40	16.52	17.46	18.28
.16	17.92	19.70	21.06	22.22	23.22
.18	22.38	24.50	26.12	27.48	28.70
.20	27.30	29.78	31.68	33.30	34.70

TABLE 18
 Maximum Interior Support Reaction for Cold-Formed Steel Sections
 ($F_{\gamma} = 80$ ksi)

$$Q_{\gamma} = 1.5t \sqrt{F_{\gamma}} [6.66 + 1.446(N/t) \sqrt{1/2}]$$

$$= 120t \sqrt{F_{\gamma}} [6.66 + 1.446(N/t) \sqrt{1/2}] \text{ kips}$$

N = Bearing Length, in

Sheet thickness t (in)	Q_{γ} , kips				
	N = 1	N = 2	N = 3	N = 4	N = 5
.02	.82	1.02	1.16	1.30	1.42
.04	2.66	3.24	3.68	4.06	4.38
.06	5.42	6.48	7.30	7.98	8.58
.08	9.04	10.66	11.92	12.96	13.93
.10	13.48	15.76	17.50	18.96	20.26
.12	18.72	21.70	24.00	25.94	27.64
.14	24.76	28.52	31.40	33.84	35.98
.16	31.56	36.16	39.70	42.68	45.30
.18	39.14	44.64	48.84	52.40	55.52
.20	47.48	53.92	58.64	63.00	66.68

EQUATIONS:

$$P/P_{ex} + C_{mx}M_{rx} / (1 - P/P_{ex})M_{rx} + C_{my}M_{ry} / (1 - P/P_{ey})M_{my} < / = 1.0 \quad (107a)$$

$$P/P_{px} + M_{rx} / 1.18M_{px} + M_{ry} / 1.18M_{py} < / = 1.0 \text{ for } P/P_{px} > / = 0.15 \quad (107b)$$

or:

$$M_{rx} / M_{px} + M_{ry} / M_{py} < _ 1.0 \text{ for } P/P_{px} < 0.15 \quad (107c)$$

where,

M_{rx} , M_{ry} = maximum applied moments about the x- and y-axes

P = applied axial load

P_{ex} = $23/12AF'_{ex}$

P_{ey} = $23/12AF'_{ey}$

F'_{ex} = $12L^2E / [23(K*1_{bx} / r_{rx})^2]$

F'_{ey} = $12L^2E / [23(K*1_{by} / r_{ry})^2]$

$*1_{bx}$ = actual unbraced length in the plane of bending

r_{rx} , r_{ry} = corresponding radii of gyration

P_{px} = AF_{dy}

C_{mx} , C_{my} = coefficients applied to bending term in interaction formula and dependent upon column curvature caused by applied moments (AISC Specification, Section 1.6.1)

M_{px} , M_{py} = plastic bending capacities about x and y axes

($M_{px} = Z_{rx}F_{dy}$, $M_{py} = Z_{ry}F_{dy}$)

M_{mx} , M_{my} = moments that can be resisted by the member in the absence of axial load.

(a) For columns braced in the weak direction:

$$\text{EQUATIONS: } M_{mx} = M_{px} \quad (108a)$$

$$M_{my} = M_{py} \quad (108b)$$

(b) For columns unbraced in the weak direction:

$$\text{EQUATIONS: } M_{mx} = [1.07 - (*1/r_{ry})(F_{dy})^{1/2} / 3160]M_{px} < / = M_{px} \quad (109a)$$

$$M_{my} = [1.07 - (*1/r_{rx})(F_{dy})^{1/2} / 3160]M_{py} < / = M_{py} \quad (109b)$$

Subscripts x and y indicate the axis of bending about which a particular design property applies.

(c) Columns may be considered braced in the weak direction if the distance between any adjacent braced points is not greater than $*l_{rc}$ defined as:

$$\text{EQUATIONS: } *l_{rc}/r_{y} = 1,375/F_{dy}, \quad -1.0 < M/M_p < -0.5 \quad (110a)$$

$$*l_{rc}/r_{y} = 1,375/F_{dy} + 25, \quad -0.5 < M/M_p < 1.0 \quad (110b)$$

Beam columns should also satisfy the requirements of paragraph 3.a.(7) of this section.

b. Effective Length Ratios for Beam Columns. The basis for determining the effective lengths of beam columns for use in the calculation of P_u , P_{ex} , P_{ey} , M_{mx} , and M_{my} in plastic design is outlined below.

(1) For plastically designed braced and unbraced planar frames which are supported against displacement normal to their planes, the effective length ratios in Tables 19 and 20 shall apply.

(a) Table 19 corresponds to bending about the strong axis of a member, while Table 20 corresponds to bending about the weak axis. In each case, $*l$, is the distance between points of lateral support corresponding to r_x or r_y , as applicable. The effective length factor, K , in the plane of bending shall be governed by the provisions of paragraph 5.c. of this section.

(b) For columns subjected to biaxial bending, the effective lengths given in Tables 19 and 20 apply for bending about the respective axes, except that P_u for unbraced frames shall be based on the larger of the ratios $K*l/r_x$ or $K*l/r_y$. In addition, the larger of the slenderness ratios, $*l/r_x$ or $*l/r_y$, shall not exceed C_c .

TABLE 19

Effective Length Ratios for Beam Columns
(Webs of members in the plane of the frame;
i.e., bending about the strong axis)

	Braced Planar Frames[*]	One- and Two-Story Unbraced Planar Frames[*]
P_u	Use larger of $*l/r_y$ or l/r_x	Use larger of $*l/r_y$ or $K*l/r_x$
P_{ex}	Use $*l/r_x$	Use $K*l/r_x$
M_{mx}	Use $*l/r_y$	Use $*l/r_y$
[*] $*l/r_x$ shall not exceed C_c .		

TABLE 20

Effective Length Ratios for Beam Columns
(Flanges of members in the plane of the frame;
i.e., bending about the weak axis)

Braced Planar Frames[*]	One- and Two-Story Unbraced Planar Frames[*]
$P_{\Gamma u}$ Use larger of $*l/r_{\Gamma y}$ or $*l/r_{\Gamma x}$	Use larger of $*l/r_{\Gamma x}$ or $K*l/r_{\Gamma y}$
$P_{\Gamma ey}$ Use $*l/r_{\Gamma y}$	Use $K*l/r_{\Gamma y}$
$M_{\Gamma my}$ Use $*l/r_{\Gamma x}$	Use $*l/r_{\Gamma x}$
[*] $*l/r_{\Gamma y}$ shall not exceed $C_{\Gamma c}$.	

c. Effective Length Factor, K. In plastic design, it is usually sufficiently accurate to use the K factors from Table C.1.8.1 of the AISC Manual (reproduced here as Table 21) for the condition closest to that in question rather than to refer to the alignment chart (Fig. C.1.8.2 of AISC Manual). It is permissible to interpolate between different conditions in Table 21 using engineering judgment. In general, a design K value of 1.5 is conservative for the columns of unbraced frames when the base of the columns is assumed pinned, since conventional column base details will usually provide partial rotational restraint at the column base. For girders of unbraced frames, a design K value of 0.75 is recommended.

6. FRAME DESIGN.

a. Introduction.











(1) The dynamic plastic design of frames for blast resistant structures is oriented toward industrial building applications common to ammunition manufacturing and storage facilities, i.e., relatively low, single story, multi-bay structures. This treatment applies principally to acceptor structures subjected to relatively low blast overpressures.

(2) The design of blast resistant frames is characterized by: (a) simultaneous application of vertical and horizontal pressure-time loadings with peak pressures considerably in excess of conventional loads; (b) design criteria permitting inelastic local and overall dynamic structural deformations (deflections and rotations); and (c) design requirements dictated by the operational needs of the facility and, often, the need for reusability, with minor repair work, following an accidental explosion.

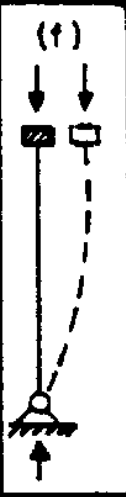
(3) Rigid frame construction is recommended in the design of blast resistant structures since this system provides open interior space combined with substantial resistance to lateral forces. In addition, this type of construction possesses inherent energy absorption capability due to the successive development of plastic hinges up to the ultimate capacity of the structure.

TABLE 21

Effective Length Factors for Columns and Beam-Columns

Buckled shape of column is shown by dashed line						
Theoretical K value	0.5	0.7	1.0	1.0	2.0	2.0
Recommended design value when ideal conditions are approximated	0.65	0.80	1.2	1.0	2.10	2.0
End condition code	    	Rotation fixed and translation fixed. Rotation free and translation fixed. Rotation fixed and translation free. Rotation free and translation free.				

(4) The particular objective in this section is to provide rational procedures for efficiently performing the preliminary design of blast resistant frames. Rigid frames as well as frames with supplementary bracing and with rigid or non-rigid connections are considered. In both cases, preliminary dynamic load factors are provided for establishing equivalent static loads for both the local and overall frame mechanism. Based upon the mechanism method, as employed in static plastic design, estimates are made for the required plastic bending capacities as well as approximate values for the axial loads and shears in the frame members. The dynamic deflections and rotations in the sidesway and local beam mechanism modes are estimated based upon single degree-of-freedom analyses. The design criteria and the procedures for the design of individual members previously discussed apply for this preliminary design procedure.

(5) In order to confirm that a trial design meets the recommended deformation criteria and to verify the adequacy of the member sizes established on the basis of estimated dynamic forces and moments, a rigorous frame analysis should be performed. Several computer programs are available through various Department of Defense agencies which perform a multi-degree-of-freedom, non-linear, dynamic analysis of braced and unbraced, rigid and non-rigid frames of one or more stories.

b. Single-Story Rigid Frames.

(1) Collapse Mechanism. General expressions for the collapse mechanism of single-story rigid frames are presented in Table 22 for pinned and fixed base frames subjected to combined vertical and horizontal loading.

(a) The design objective is to proportion the frame members such that the governing mechanism represents an economical solution. For a particular frame within a framing system, the ratio of total horizontal to vertical peak loading, denoted by $[\alpha]$ is influenced by the horizontal framing plan of the structure and is determined as follows:







$$\text{EQUATION:} \quad [\alpha] = q_{rh} / q_{rv} \quad (111)$$

where,

$$\begin{aligned} q_{rv} &= p_{rv} b_{rv} = \text{peak vertical load on rigid frame} \\ q_{rh} &= p_{rh} b_{rh} = \text{peak horizontal load on rigid frame} \\ p_{rv} &= \text{blast overpressure on roof} \\ p_{rh} &= \text{reflected blast pressure on front wall} \\ b_{rv} &= \text{tributary width for vertical loading} \\ b_{rh} &= \text{tributary width for horizontal loading} \end{aligned}$$

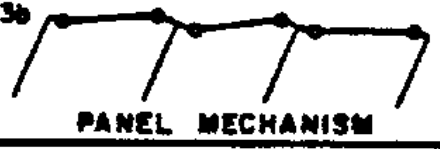
The value of $[\alpha]$ will usually lie in the range from about 1.8 to 2.5 when the shock front is parallel to the roof purlins. In this case the roof purlins are supported by the frame and the tributary width is the same for the horizontal and vertical loading. The value of $[\alpha]$ is much higher when the shock front is perpendicular to the roof purlins. In this case, the roof purlins are not supported by the girder of the frame and the tributary width of the vertical loading (b_{rv} = purlin spacing) is much smaller than the tributary width of the horizontal loading (b_{rh} = frame spacing).

TABLE 22
Collapse Mechanisms for Rigid Frames
with Fixed and Pinned Bases

Collapse Mechanism	Plastic Moment M_p	
	Pinned Bases	Fixed Bases
 BEAM MECHANISM	$\frac{wL^2}{16}$	$\frac{wL^2}{16}$
 BEAM MECHANISM	$\frac{\alpha wH^2}{4(2C+1)}$	$\frac{\alpha wH^2}{4(3C+1)}$
 PANEL MECHANISM	$\frac{\alpha wH^2}{2} \cdot \frac{1}{2+(n-1)C_1}$ ($C_1 \geq 2$) ^a	$\frac{\alpha wH^2}{4} \cdot \frac{1}{1+(n-1)C_1+C}$ ($C_1 \geq 2$) ^a
 PANEL MECHANISM	$\frac{\alpha wH^2}{4n}$ ($C_1 \geq 2$) ^a	$\frac{\alpha wH^2}{2} \cdot \frac{1}{2(n+C)+(n-1)C_1}$ ($C_1 \geq 2$) ^a
 COMBINED MECHANISM	$\frac{w}{8n} (\alpha H^2 + \frac{n}{2} L^2)$	$\frac{w}{2} \cdot \frac{\alpha H^2 + \frac{n}{2} L^2}{2(2n+C)+(n-1)C_1}$
 COMBINED MECHANISM	$\frac{\frac{3}{8} \alpha wH^2}{C + \frac{1}{2} + \frac{C_1}{2}(n-1)}$ ($C_1 \geq 2$) ^a	$\frac{\frac{3}{8} \alpha wH^2}{\frac{5}{2}C + (n-1)C_1 + \frac{1}{2}C_1}$ ($C_1 \geq 2$) ^a
 COMBINED MECHANISM	$\frac{\frac{3}{8} \alpha wH^2}{C + (n - \frac{1}{2})}$ ($C_1 \geq 2$) ^a	$\frac{\frac{3}{8} \alpha wH^2}{\frac{3}{2}C + (n-1)\frac{C_1}{2} + (n - \frac{1}{2})}$ ($C_1 \geq 2$) ^a
 COMBINED MECHANISM	$\frac{w}{8} \frac{[3\alpha H^2 + (n-1)L^2]}{C + (2n - \frac{3}{2})}$	$\frac{w}{8} \frac{[3\alpha H^2 + (n-1)L^2]}{\frac{5}{2}C + (n-1)\frac{C_1}{2} + (2n - \frac{3}{2})}$

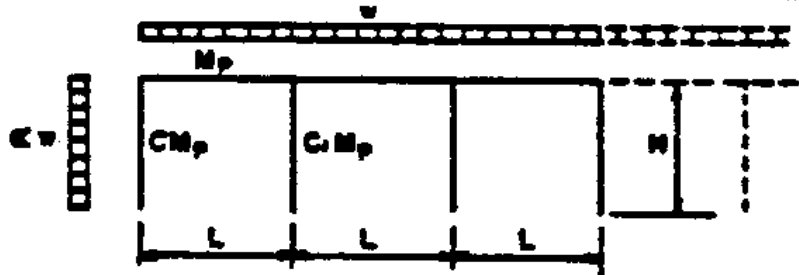

n = Number of bays = 1, 2, 3...
 w = Uniform equivalent static load

• For $C_1 = 2$ hinges form in the girders and columns of interior joints.

(b) It is assumed that the plastic bending capacity of the roof girder, M_{rp} , is constant for all bays. The capacity of the exterior and interior columns are taken as CM_{rp} and $C_{rl}M_{rp}$, respectively. Since the exterior column is generally subjected to reflected pressures, it is recommended that a value of C greater than 1.0 be selected.

(c) In analyzing a given frame with certain member properties, the controlling mechanism is the one with the lowest resistance. In design, however, the load is fixed and the required design plastic moment is the largest M_{rp} value obtained from all possible mechanisms. For that purpose, C and C_{rl} should be selected so as to minimize the value of the maximum required M_{rp} from among all possible mechanisms. After a few trials it will become obvious which choice of C and C_{rl} tends to minimize the largest value of M_{rp} .

(2) Dynamic Deflections and Rotations. It will normally be more economical to proportion the members so that the controlling failure mechanism is a combined mechanism rather than a beam mechanism. The mechanism having the least resistance constitutes an acceptable mode of failure provided that the magnitudes of the maximum deflections and rotations do not exceed the maximum values presented in paragraph 1.b of this section.

(3) Dynamic Load Factors. To obtain initial estimates of the required mechanism resistance, the dynamic load factors of Table 23 may be used to obtain equivalent static loads for the indicated mechanisms. These load factors are necessarily approximate and make no distinction for different end conditions. However, they are expected to result in reasonable estimates of the required resistance for a trial design. Once the trial member sizes are established, then the natural period and deflection of the frame can be calculated. The dynamic load factors of Table 23 are presented for both reusable and non-reusable frames. In each case, the factors for a panel or combined sidesway mechanism are lower than those for a beam mechanism, since the natural period of a sidesway mode will normally be greater than the natural periods of the individual elements.

TABLE 23

Dynamic Load Factors (DLF) and Equivalent Static Loads for Trial Design

Collapse mechanism	Reusable	Structure Non-reusable
Beam	1.0	0.8
Panel or combined	0.5	0.35

Equivalent static vertical load = $q_{rv} \times \text{DLF} = w$

Equivalent static horizontal load = $q_{rh} \times \text{DLF} = w$

(4) Loads in Frame Members. Estimates of the peak axial forces in the girders and the peak shears in the columns are obtained from Figure 45. In applying the equations of Figure 45, the equivalent horizontal static load shall be computed using the dynamic load factor for a panel or combined sidesway mechanism.

Preliminary values of the peak axial loads in the columns and the peak shears in the girders may be computed by multiplying the equivalent vertical static load by the roof tributary area. Since the axial loads in the columns are due to the reaction from the roof girders, the equivalent static vertical load should be computed using the dynamic load factor for the beam mechanism.

(5) Sizing of Frame Members. Each member in a frame under the action of horizontal and vertical blast loads is subjected to combined bending moments and axial loads. However, the phasing between critical values of the axial force and bending moment cannot be established from a simplified analysis. Therefore, it is recommended that the peak axial loads and moments obtained from Figure 45 be assumed to act concurrently for the purpose of beam-column design. The resistance of the frame depends upon the ultimate strength of the members acting as beam-columns.

(a) The columns and girders in the exterior frames are subject to biaxial bending due to the simultaneous action of vertical pressures on the roof and horizontal pressures on the exterior walls. Interior girders are subjected to bending in one direction only. However, interior columns may be subjected to uniaxial or biaxial bending depending upon the direction of the applied blast load. When the plane of the shock front is parallel to a face of the building, frame action occurs in one direction, namely, in the direction of shock front propagation. The frames in the transverse direction are subjected to equal loads at each end, hence no sidesway and therefore no frame action. When a blast wave impinges on the building from a quartering direction, frame action occurs in the two directions due to the unbalanced loads in each direction. In such cases, the moments and forces are calculated by analyzing the response of the frame in each direction for the appropriate components of the load. The results in each direction are then superimposed in order to perform the analysis or design of the beams, columns, and beam-columns of the structure. This approach is generally conservative since it assumes that the peak values of the forces in each direction occurs simultaneously throughout the three-dimensional structure.

(b) Having estimated the maximum values of the forces and moments throughout the frame, the preliminary sizing of the members can be performed using the criteria previously presented for beams and columns.

(6) Stiffness and Deflection. The stiffness factor, K , for single-story rectangular frames subjected to uniform horizontal loading is defined in Table 24. Considering an equivalent single degree-of-freedom system, the sidesway natural period of this frame is:

$$\text{EQUATION:} \quad T_{N1} = 2[\pi] (m_{e1} / KK_{L1})^{1/2} \quad (112)$$

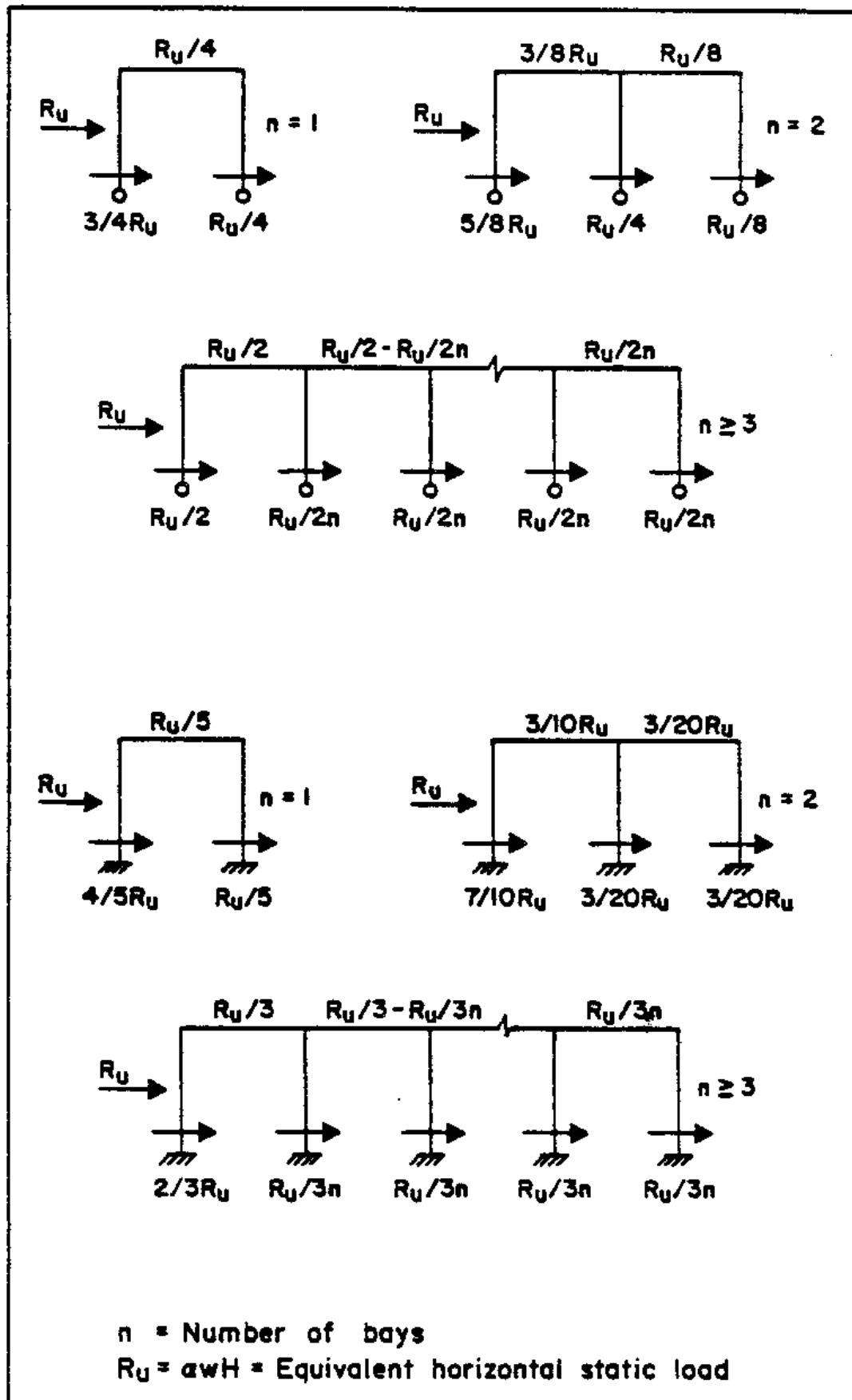

FIGURE 45

Estimates of Peak Shears and Axial Loads
in Rigid Frames Due to Horizontal Loads

2.08-160

TABLE 24

Stiffness Factors for Single Story, Multi-Bay Rigid Frame
Subjected to Uniform Horizontal Loading

$$\text{STIFFNESS FACTOR } K = \frac{E I_{ce}}{H^3} \cdot C_2 \cdot [1 + (0.7 - 0.1\beta)(n-1)]$$

n = Number of Bays

β = Base Fixity Factor†

$$D = \frac{I_g / L}{I_{ce} (0.75 + 0.25\beta) / H}$$

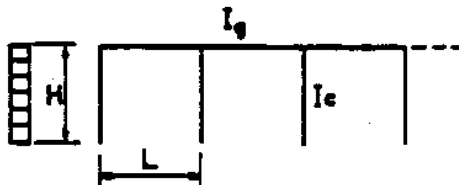

I_{ce} = Average Column Moment
of Inertia = $\sum I_c / (n+1)$

D	C_2		
	$\beta = 1.0$	$\beta = 0.5^*$	$\beta = 0$
0.25	26.7	14.9	3.06
0.50	32.0	17.8	4.65
1.00	37.3	20.6	6.04

* Values of C_2 are Approximate for this β

† $\beta = 1.0$ For Fixed Base
= 0.0 For Hinged Base

where,

m_{fe} is the equivalent lumped mass
 K is the frame stiffness, k/in
 K_{L_1} is a load factor.

The product KK_{L_1} is the equivalent stiffness due to a unit load applied at m_{fe} . The load factor, K_{L_1} , is given by:

$$\text{EQUATION:} \quad K_{L_1} = 0.55 (1 - 0.25[\text{beta}]) \quad (113)$$

where,

[beta] = base fixity factor; 0 for pinned base; 1.0 for fixed base

(a) The equivalent mass, m_{fe} , to be used in calculating the period of a sidesway mode consists of the total roof mass plus 1/3 of the column and wall masses. Since all of these masses are considered to be concentrated at the roof level, the mass factor, $K_{M_1} = 1.0$.

The limiting resistance, R_{fu} , is given by:

$$\text{EQUATION:} \quad R_{fu} = [\text{alpha}]wH \quad (114)$$

where,

w = equivalent static load based on the dynamic load factor for a panel or combined sidesway mechanism.

The equivalent elastic deflection, X_{fe} , corresponding to R_{fu} is:

$$\text{EQUATION:} \quad X_{fe} = R_{fu} / K_{fe} \quad (115)$$

(b) The ductility ratio for the sidesway deflection of the frame can be computed using the dynamic response chart, Figure 6-7 of NAVFAC P-937. The maximum deflection, X_{fm} , is then calculated from:

$$\text{EQUATION:} \quad X_{fm} = [\mu]X_{fe} \quad (116)$$

where,

[mu] = ductility ratio in sidesway.

c. Single-Story Frames with Supplementary Bracing.

(1) Collapse Mechanism. The possible collapse mechanisms of single-story frames with diagonal tension bracing (X-bracing) are presented in Tables 25 and 26 for pinned-base frames with rigid and non-rigid girder-to-column connections. In these tables, the cross-sectional area of the tension brace is denoted by A_{rb} , the dynamic yield stress for bracing member is F_{rdy} , and the number of braced bays is denoted by the parameter m . In each case, the ultimate capacity of the frame is expressed in terms of the equivalent static load and the member ultimate strength (either M_{rp} or $A_{rb}F_{rdy}$). In developing these expressions in the tables, the same assumptions were made as for rigid frames, i.e., M_{rp} for the roof girder is constant for all bays, the bay width, L , is constant and the column moment capacity coefficient, C , is greater than 1.0. For rigid frames with tension bracing it is necessary to vary C , C_{rl} , and A_{rb} in order to achieve an economical design. When non-rigid girder to column connections are used, C and C_{rl} drop out of the resistance function for the sidesway mechanism and the area of the bracing can be calculated directly.

(2) Bracing Ductility Ratio. Tension brace members are not expected to remain elastic under the blast loading. Therefore, it is necessary to determine if this yielding will be excessive when the system is permitted to deflect to the limits of the design criteria previously given.

(a) The ductility ratio associated with tension yielding of the bracing is defined as the maximum strain in the brace divided its yield strain. Assuming small deflections and neglecting axial deformations in the girders and columns, the ductility ratio is given by:

$$\text{EQUATION:} \quad [\mu] = [\delta] (\cos^2 \gamma) E / L F_{rdy} \quad (117a)$$

where,

$[\mu]$ = ductility ratio
 $[\delta]$ = sidesway deflection
 $[\gamma]$ = vertical angle between the bracing and a horizontal plane
 L = bay width

(b) From the deflection criteria, the sidesway deflection is limited to $H/50$ for reusable structures and to $H/25$ for non-reusable structures. The ductility ratio can be expressed further as:

$$\text{EQUATION:} \quad [\mu] = (H/50L) (\cos^2 \gamma) (E/F_{rdy}) \quad (117b)$$







for reusable structures, and as:

$$\text{EQUATION:} \quad [\mu] = (H/25L) (\cos^2 \gamma) (E/F_{rdy}) \quad (117c)$$

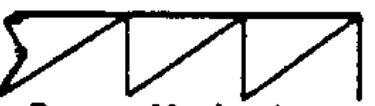
for non-reusable structures.

TABLE 25

Collapse Mechanisms for Rigid Frames with Supplementary Bracing and Pinned Bases

Collapse Mechanism	Plastic Moment M_p
1  Beam Mechanism	$\frac{wL^2}{16}$
2  Beam Mechanism	$\frac{\alpha wH^2}{4(2C+1)}$
3a  Panel Mechanism	$\left(\frac{\alpha wH^2}{2} - m A_b F_{dy} H \cos \gamma\right) \frac{1}{\frac{2+(n-1)C_1}{(C_1+2)^2}}$
3b  Panel Mechanism	$\frac{\alpha wH^2}{4n} - \frac{m A_b F_{dy} H \cos \gamma}{2n}$ $(C_1 \geq 2)^*$
4  Combined Mechanism	$\frac{w}{8n} (\alpha H^2 + \frac{nL^2}{2}) - \frac{m A_b F_{dy} H \cos \gamma}{4n}$
5a  Combined Mechanism	$\frac{\frac{3}{8}\alpha w H^2 - \frac{m}{2} A_b F_{dy} H \cos \gamma}{C_1 + \frac{1}{2} + \frac{C_1}{2}(n-1)}$ $(C_1 \leq 2)^*$
5b  Combined Mechanism	$\frac{\frac{3}{8}\alpha w H^2 - \frac{m}{2} A_b F_{dy} H \cos \gamma}{c + (n - \frac{1}{2})}$ $(c \geq 2)^*$
6  Combined Mechanism	$\frac{w}{8} [3\alpha H + (n-1)L] - \frac{m}{2} A_b F_{dy} H \cos \gamma$ $c + (2n - \frac{3}{2})$

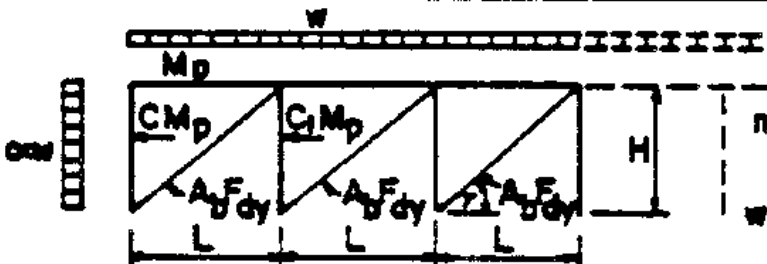





$n = \text{Number of bays} = 1, 2, 3, \dots$
 $w = \text{Uniform equivalent static load}$

* For $C_1 = 2$ hinges form in the girders and columns at interior joints.

TABLE 26

Collapse Mechanisms for Frames with Supplementary Bracing,
Non-Rigid Girder to Column Connections and Pinned Bases

Collapse Mechanism	Ultimate Capacity	Framing Type
1  Beam Mechanism Exterior Girder	$M_p = wL^2/8$ $M_p = wL^2/12$ $M_p = wL^2/16$	① ② ③
2  Beam Mechanism Interior Girder	$M_p = wL^2/8$ $M_p = wL^2/6$	① ② & ③
3  Beam Mechanism Blastward Column	$M_p = \alpha wH^2/8$ $M_p = \frac{\alpha wH^2}{4(2C+1)}$	① & ② ③
4  Panel Mechanism	$A_b F_{dy} = \alpha wH/2m \cos \gamma$ $A_b F_{dy} = \frac{\alpha wH}{2m \cos \gamma} - \frac{2M_p}{mH \cos \gamma}$	① & ② ③
5  Combined Mechanism	$A_b F_{dy} = \frac{3\alpha wH}{4m \cos \gamma} - \frac{(2C+1)M_p}{mH \cos \gamma}$	③

GIRDER FRAMING TYPE:

- ① Girder simply supported between columns.
- ② Girder continuous over columns.
- ③ Girder continuous over columns and rigidly connected to exterior columns only.

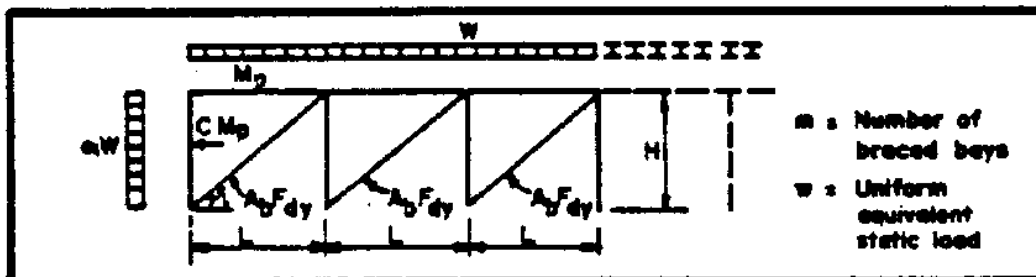

(3) Dynamic Load Factor. The dynamic load factors listed in Table 23 may also be used as a rational starting point for a preliminary design of a braced frame. In general, the sidesway stiffness of braced frames is greater than unbraced frames and the corresponding panel or sidesway dynamic load factor may also be greater. However, since Table 23 is necessarily approximate and serves only as a starting point for a preliminary design, refinements to this table for frames with supplementary diagonal braces are not warranted.

(4) Loads in Frame Members. Estimates of the peak axial loads in the girders and the peak shears in the columns of a braced rigid frame are obtained from Figure 46. It should be noted that the shear in the blastward column and the axial load in the exterior girder are the same as the rigid frame shown in Figure 45. The shears in the interior columns V_2 are not affected by the braces while the axial loads in the interior girders P are reduced by the horizontal components of the force in the brace $F_{\Gamma H\gamma}$. If a bay is not braced, then the value of $F_{\Gamma H\gamma}$ must be set equal to zero when calculating the axial load in the girder of the next braced bay. To avoid an error, horizontal equilibrium should be checked using the formula:

$$\text{EQUATION:} \quad R_{\Gamma U\gamma} = V_1 + nV_2 + mF_{\Gamma H\gamma} \quad (118)$$

where,

$R_{\Gamma U\gamma}$, V_1 , V_2 and $F_{\Gamma H\gamma}$ are defined in Figure 46
 n = number of bays
 m = number of braced bays

In addition, the value of $M_{\Gamma P\gamma}$ used in Figure 46 is simply the design plastic moment obtained from the controlling panel or combined mechanism.

(a) An estimate of the peak loads for braced frames with non-rigid girder to column connections may be obtained using Figure 46. However, the value of $M_{\Gamma P\gamma}$ must be set equal to zero. For such cases, the entire horizontal load is taken by the exterior column and the bracing. There is no shear force in the interior columns.

(b) Preliminary values of the peak axial loads in the columns and the peak shears in the girders are obtained in the same manner as rigid frames. However, in computing the axial loads in the columns, the vertical components of the forces in the tension braces must be added to the vertical shear in the roof girders. The vertical component of the force in the brace is given by:

$$\text{EQUATION:} \quad F_{\Gamma V\gamma} = A_{\Gamma b\gamma} F_{\Gamma d\gamma} \sin [\gamma] \quad (119)$$

(c) The reactions from the braces will also affect the load on the foundation of the frame. The design of the footings must include these loads.

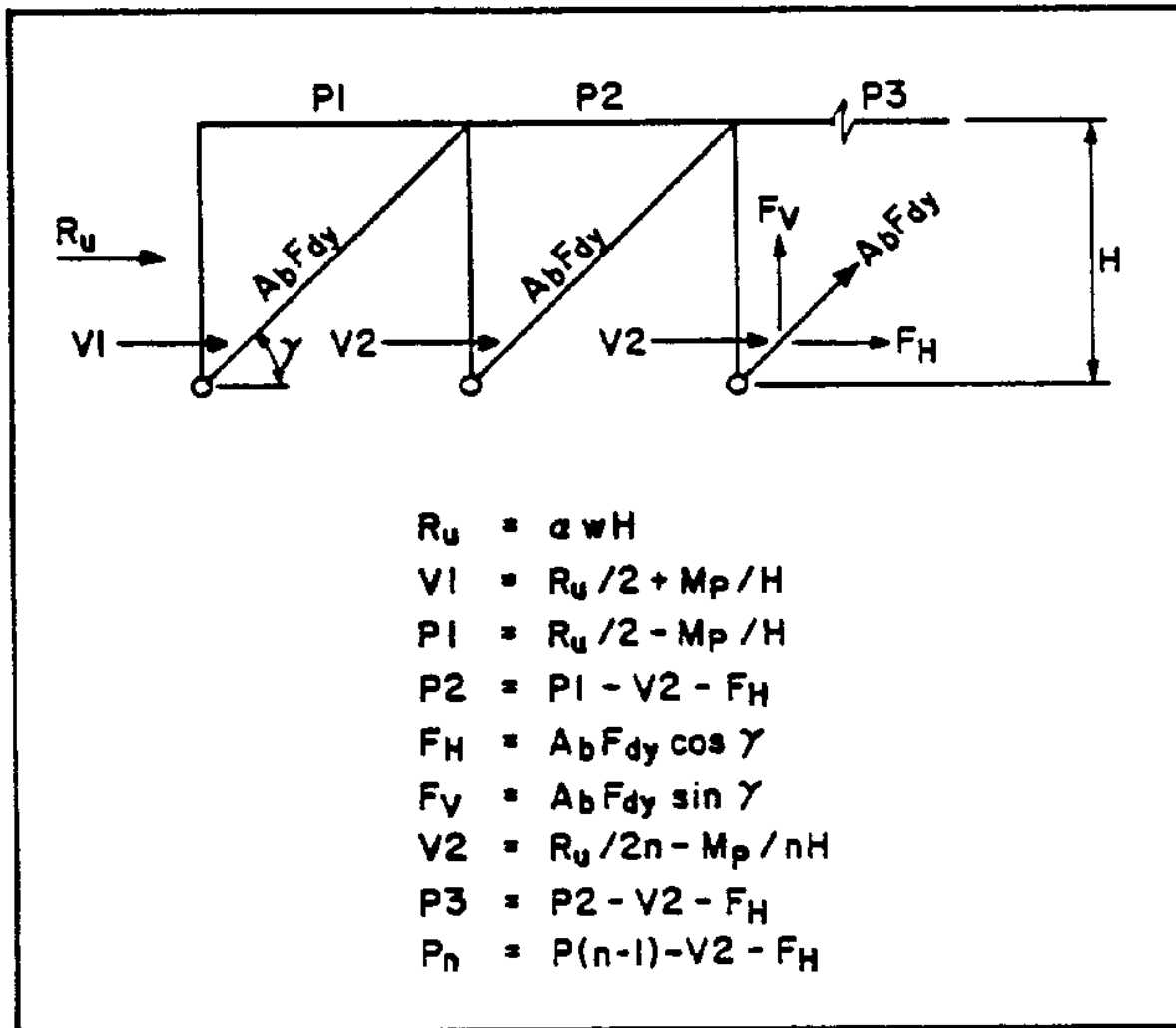

FIGURE 46

Estimates of Peak Shears and Axial Loads
in Braced Frames Due to Horizontal Loads

(5) Stiffness and Deflection. The provisions for rigid frames may be used for braced frames with the following modifications:

(a) The sidesway natural period of a frame with supplementary diagonal bracing is given by:

$$\text{EQUATION: } T_{1N} = 2[\pi] [m_{1e} / (K_{1L} + K_{1b})]^{1/2} \quad (120)$$

in which K_{1b} is the horizontal stiffness of the tension bracing given by:

$$\text{EQUATION: } K_{1b} = (nA_{1b}E \cos^3[\gamma]) / L \quad (121)$$

where K , K_{1L} , and m_{1e} are the equivalent frame stiffness, frame load factor, and effective mass, respectively, as defined for rigid frames.

(b) The elastic deflection of a braced frame is given by:

$$\text{EQUATION: } X_{1E} = R_{1u} (K_{1L} + K_{1b}) \quad (122)$$

It should be noted that the frame stiffness, K , is equal to zero for braced frames with non-rigid girder to column connections.

(6) Slenderness Requirements for Diagonal Braces. The slenderness ratio of the bracing should be less than 300 to prevent vibration and "slapping". This design condition can be expressed as:

$$\text{EQUATION: } r_{1b} \geq l_{1b} / 300 \quad (123)$$

where,

r_{1b} = minimum radius of gyration of the bracing member
 l_{1b} = length between points of support

The X-bracing should be connected together where they cross even though a compression brace is not considered effective in providing resistance. In this manner, l_{1b} for each brace may be taken equal to half of its total length.

(7) Sizing of Frame Members. Estimating the maximum forces and moments in frames with supplementary bracing is similar to the procedures described for rigid frames. However, the procedure is slightly more involved since it is necessary to assume a value for the brace area in addition to the assumptions for the coefficients C and C_{1l} . For frames with non-rigid connections, C and C_{1l} do not appear in the resistance formula for a sidesway mechanism and A_{1b} can be determined directly.

In selecting a trial value of A_{rb} for frames with rigid connections, the minimum brace size will be controlled by slenderness requirements. In addition, in each particular application, there will be a limiting value of A_{rb} beyond which there will be no substantial weight savings in the frame members since there are maximum slenderness requirements for the frame members. In general, values of A_{rb} of about 2 square inches will result in a substantial increase in the overall resistance for frames with rigid connections. Hence, an assumed brace area in this range is recommended as a starting point. The design of the beams and columns of the frames follow the procedures previously presented.

7. CONNECTIONS.

a. Dynamic Design Stresses for Connections. As stated in Chapter 6 of Design of Steel Structures to Resist the Effects of HE Explosions, by Healey, the connections in a steel structure designed in accordance with plastic design concepts must fulfill their functions up to the ultimate load capacity of the structure. The AISI Specification states that bolts, rivets and welds shall be proportioned to resist the maximum forces, using stresses equal to 1.7 times those given in Part I of the same Specification. Additionally, these stresses are increased by the dynamic increase factor specified in paragraph 2.a of this section. Hence:

$$\text{EQUATION:} \quad F_{rdy} = 1.7cF_{rs} \quad (124)$$

where,

F_{rdy} = the maximum dynamic yield stress
 c = the dynamic increase factor
 F_{rs} = allowable static design stress

Note: Rather than compiling new tables for maximum dynamic loads for the various types of connections, the designer will find it advantageous to divide the forces being considered by the factor $1.7c$ and then refer to the allowable load tables.

b. Requirements for Panel Connections. Panel connections generally involve two types, namely: the attachment of light-gage materials to each other and the attachment of sheet panels to heavier cross-section.

The most common type of fastener for decking and steel wall panels is the self-tapping screw with or without washer. The screw fastener has been the source of local failure for both conventional loads and blast pressures. Special care should therefore be exercised in designing these connections to reduce the probability of failure by using oversized washers or increasing the material thickness at the connection. Certain panel connectors are shown in Figure 47.

8. EXAMPLE PROBLEMS.

a. Design of Beams for Pressure-Time Loading.

Problem: Design a purlin or girt as a flexural member which responds to a pressure-time loading.

Given:

- (1) Pressure-time load, P-T.
- (2) Design criteria $[\theta]_{\max}$ and $[\mu]_{\max}$.
- (3) Span length, L.
- (4) Beam spacing, b.
- (5) Support conditions.
- (6) Properties and type of steel.

Solution:

- (1) Determine the equivalent static load, w, using the following preliminary dynamic load factors:

$$DLF = \begin{cases} 0.8 & \text{for a non-reusable} \\ 1.0 & \text{for a reusable} \end{cases}$$

$$w = DLF \times p \times b$$

- (2) Using the appropriate resistance formula from Table 5 and the equivalent static load derived in Step 1, determine M_{\max} .
- (3) Select a member size using Equation (83) or (84). Check the local buckling criteria of paragraph 3.a.(5) for the member chosen.
- (4) Determine the mass, m, including the weight of the decking over a distance center-to-center of purlins or girts, and the weight of the members.
- (5) Calculate the equivalent mass, m_{eq} , using Table 6-1 of NAVFAC P-397 or Table 10 of this manual.
- (6) Determine the equivalent elastic stiffness, K_{eq} , from Table 7 of this manual.
- (7) Calculate the natural period of vibration, T_{N} , using Equation (91).

- (8) Determine the total resistance, R_u , and peak pressure load, B . Enter Figure 6-7 of NAVFAC P-397 with the ratios T/T_{RN} and B/R_{uN} in order to establish the ductility ratio, $[\mu]$. Compare with given criteria.
- (9) Calculate the equivalent elastic deflection, $X_{E\gamma}$, as given by:

$$X_{E\gamma} = R_{u\gamma} / K_{E\gamma}$$

and establish the maximum deflection, $X_{m\gamma}$, given by:

$$X_{m\gamma} = [\mu]X_{E\gamma}$$

Compute the corresponding member end rotation. Compare $[\mu]$ with the criteria in paragraph 1.b. of this section.

- (10) Check for shear using Equation (92) and Table 9.
- (11) If a different member size is required, repeat Steps 1 through 10 by selecting a new dynamic load factor.

Calculation:

Given:

- (1) Pressure-time loading as shown in Figure 48a.
- (2) Design criteria: Reusable structure, maximum ductility ratio = 3, maximum end rotation $[\theta] = 1^{\circ}$, whichever governs.
- (3) Structural configuration as shown in Figure 48b.
- (4) Steel properties: $F_{y\gamma} = 36$ ksi (ASTM A36 steel);
 $E = 30 \times 10^3$ ksi.

Solution:

- (1) Determine the equivalent static load (i.e., required resistance).

$$\begin{aligned} \text{DLF} &= 1.0 \text{ for reusable structure} \\ w &= 1.0 \times 5 \times 4.5 \times 144 / 1,000 = 3.24 \text{ k/ft} \end{aligned}$$

- (2) Determine required $M_{p\gamma}$ (Table 5).

$$M_{p\gamma} = wL^2 / 8 = (3.24 \times 17^2) / 8 = 117 \text{ k-ft}$$

- (3) Select a member.

$$\begin{aligned} (S + Z) &= 2M_{p\gamma} / F_{dy\gamma} = (2 \times 117 \times 12) / 39.6 \\ &= 71.0 \text{ in}^3 \end{aligned}$$

$$\text{where } F_{dy\gamma} = cF_{y\gamma} = 1.1 \times 36 = 39.6 \text{ Ksi}$$

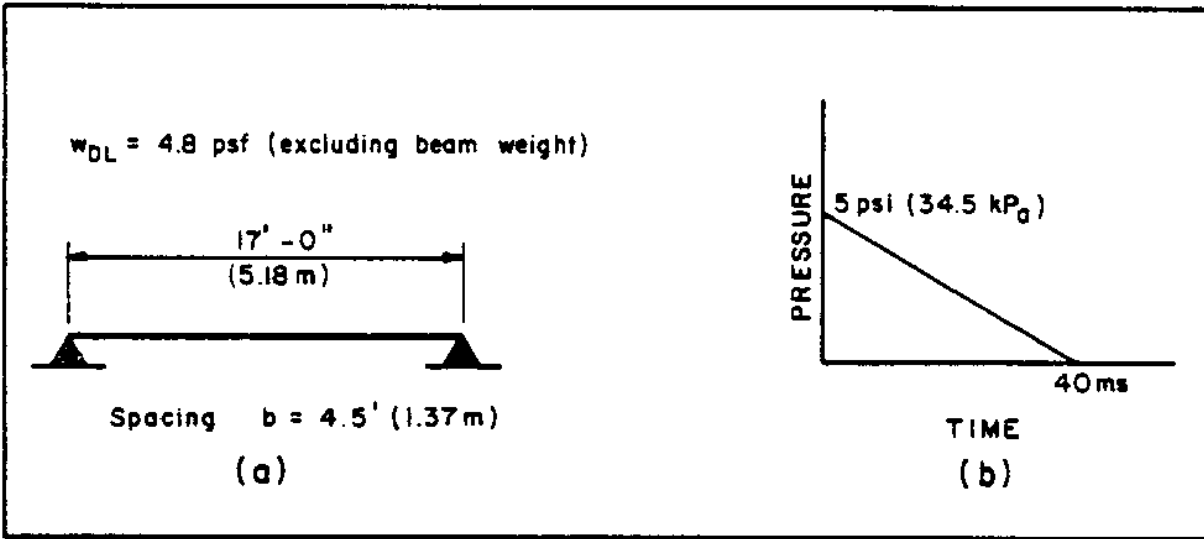

FIGURE 48
Beam Configuration and Loading

Select W12 x 26.

$$S = 33.4 \text{ in}^3$$

$$I = 204 \text{ in}^4$$

$$Z = 37.2 \text{ in}^3$$

$$S + Z = 70.6 \text{ in}^3$$

$$b_f/t_f = 8.5 < \leq 8.5 \text{ O.K.}$$

$$M_p = (70.6 \times 39.6)/(2 \times 12) = 116.5 \text{ k-ft}$$

Check local buckling criteria.

$$d/t_w = 53.1 < 412/(F_y)^{1/2} = 68.7 \text{ O.K.}$$

(4) Calculate mass, m .

$$\begin{aligned} m &= w/g \\ &= [(4.5 \times 48) + 26](10^6)/(32.2 \times 10^3) \\ &= 1478.3 \text{ (k-ms}^2\text{)}/\text{ft} \end{aligned}$$

(5) Calculate the equivalent mass, m_e , for a response in the elasto-plastic range.

$$K_{LM} = (0.79 + 0.66)/2 = 0.725$$

$$\begin{aligned} m_e &= 0.725 \times 1478.3 \\ &= 1071.8 \text{ (k-ms}^2\text{)}/\text{ft} \end{aligned}$$

(6) Determine K_E (Table 7).

$$\begin{aligned} K_E &= 384EI/5L^4 \\ &= (384 \times 30 \times 10^3 \times 204)/(5 \times 17^4 \times 144) \\ &= 39.1 \text{ k}/\text{ft} \end{aligned}$$

(7) Calculate T_N .

$$\begin{aligned} T_N &= 2[\pi] (m_e/K_E)^{1/2} \\ &= 2[\pi] (1071.8/39.1)^{1/2} \\ &= 33 \text{ ms} \end{aligned}$$

(8) Establish the ductility ratio and compare with the criteria.

$$T/T_N = 40/33 = 1.21$$

$$\begin{aligned} B &= p \times b \\ &= (4.3 \times 4.5 \times 144)/1,000 \\ &= 2.79 \text{ k}/\text{ft} \end{aligned}$$

$$\begin{aligned}
 r_{\Gamma u_{\Gamma}} &= 8M_{\Gamma p_{\Gamma}} / L L_2^{\Gamma} \\
 &= (8 \times 116.5) / (17) L_2^{\Gamma} \\
 &= 3.22 \text{ k/ft}
 \end{aligned}$$

$$B/r_{\Gamma u_{\Gamma}} = 2.79/3.22 = 0.87$$

From Figure 6-7 of NAVFAC P-397:

$$[\mu] = X_{\Gamma m_{\Gamma}} / X_{\Gamma E_{\Gamma}} = 1.65 < 3 \text{ O.K.}$$

(9) Determine $X_{\Gamma E_{\Gamma}}$.

$$\begin{aligned}
 X_{\Gamma E_{\Gamma}} &= r_{\Gamma u_{\Gamma}} / K_{\Gamma E_{\Gamma}} \\
 &= (3.22 \times 12) / 39.1 \\
 &= 0.99 \text{ in}
 \end{aligned}$$

Find $X_{\Gamma m_{\Gamma}}$.

$$\begin{aligned}
 X_{\Gamma m_{\Gamma}} &= [\mu] X_{\Gamma E_{\Gamma}} \\
 &= 1.65 \times 0.99 \\
 &= 1.634 \text{ in}
 \end{aligned}$$

Find end rotation, $[\theta]$.

$$\begin{aligned}
 \tan [\theta] &= X_{\Gamma m_{\Gamma}} / (L/2) \\
 &= 1.634 / (8.5 \times 12) \\
 &= 0.0160
 \end{aligned}$$

$$[\theta] < 1^{\circ} \text{ O.K.}$$

(10) Check for shear.

Dynamic yield stress in shear:

$$\begin{aligned}
 F_{\Gamma d v_{\Gamma}} &= 0.55 F_{\Gamma d y_{\Gamma}} \\
 &= 0.55 \times 39.6 \\
 &= 21.8 \text{ ksi}
 \end{aligned}$$

Dynamic shear capacity:

$$\begin{aligned}
 V_{\Gamma p_{\Gamma}} &= F_{\Gamma d v_{\Gamma}} A_{\Gamma w_{\Gamma}} \\
 &= 21.8 \times 0.23 \times 11.46 \\
 &= 57.5 \text{ k}
 \end{aligned}$$

Maximum support shear (Table 8):

$$\begin{aligned}
 V &= r_{\Gamma u_{\Gamma}} L / 2 \\
 &= (3.22 \times 17) / 2 \\
 &= 27.4 \text{ k}
 \end{aligned}$$

$$V_p > V \quad \text{O.K.}$$

b. Design of Cold-Formed, Light-Gage Steel Panels Subjected to Pressure-Time Loading.

Problem: Design a roof deck as a flexural member which responds to pressure-time transverse loading.

Given:

- (1) Pressure-time loading.
- (2) Design criteria ($[\theta]_{\max}$ and $[\mu]_{\max}$ for either reusable or non-reusable cold-formed panel).
- (3) Span length and support conditions.
- (4) Mechanical properties of steel.

Solution:

- (1) Determine an equivalent uniformly distributed static load for a 1-ft width of panel, using the following preliminary dynamic load factors:

$$DLF = \begin{cases} 1.65 & \text{reusable} \\ 1.40 & \text{non-reusable} \end{cases}$$

These load factors are based on an average value of $T/T_{RN} = 10.0$ and the design ductility ratios recommended in Equation (101). They are derived using Figure 6-7 of NAVFAC P-397.

Equivalent static load:

$$w = DLF \times p \times b$$

$$b = 1 \text{ ft.}$$

- (2) Using the equivalent load derived in Step 1, determine the ultimate moment capacity (assume positive and negative are the same).
- (3) Determine the required section moduli. Select a panel.
- (4) Determine actual section properties of the panel, S_{L+J} , S_{L-J} , I , and $m = w/g$ (for 1-ft width of a panel).
- (5) Compute r_{μ} , the maximum unit resistance per 1-ft width of panel, using Equation (98) or (99).
- (6) Determine the equivalent elastic stiffness from

$$K_{FE} = r_{\mu} / X_{FE},$$

where X_{FE} is from Equation (100).

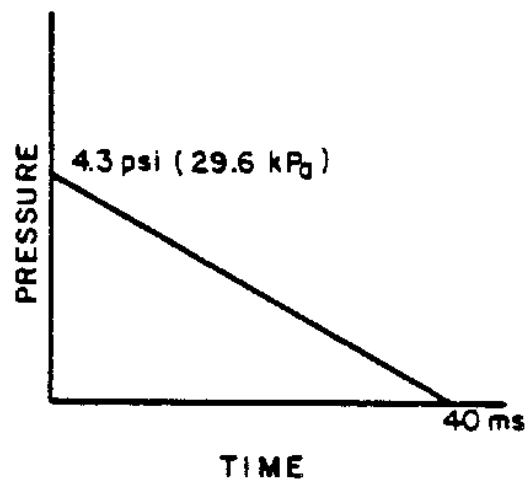

(a) PRESSURE LOADING

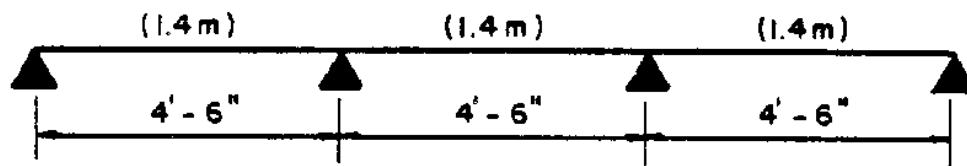

(b) ROOF DECKING CONFIGURATION

FIGURE 49
Pressure Loading and Roof Decking Configuration

Solution:

- (1) Determine the equivalent static load:

$$DLF = 1.65 \text{ (reusable)}$$

$$\begin{aligned} w &= DLF \times p \\ &= 1.65 \times 4.30 \times 144 \\ &= 1,021.7 \text{ lb/ft}^2 \end{aligned}$$

- (2) Determine required ultimate moment capacities:

$$\begin{aligned} M_{rup} &= M_{run} = wL^2/12 \\ &= 1,021.7(4.5)^2/12 \\ &= 1,724.1 \text{ lb-ft/ft} \end{aligned}$$

- (3) Determine required section moduli:

$$\begin{aligned} F_{dy} &= 1.1 \times 40,000 = 44,000 \text{ psi} \\ S_{L+J} &= S_{L-J} \\ &= (1,724 \times 12)/44,000 \\ &= 0.47 \text{ in}^3/\text{ft} \end{aligned}$$

Select a UKX 18-18, 1-1/2 inches deep.

- (4) Determine actual properties of selected section.

From manufacturer's guide:

$$\begin{aligned} S_{L+J} &= 0.472 \text{ in}^3/\text{ft} \\ S_{L-J} &= 0.591 \text{ in}^3/\text{ft} \\ I &= 0.566 \text{ in}^4/\text{ft} \\ w &= 4.8 \text{ psf} \end{aligned}$$

- (5) Compute maximum unit resistance, r_{ru} .

$$\begin{aligned} M_{rup} &= (44,000 \times 0.472)/12 \\ &= 1,730 \text{ lb-ft/ft} \\ M_{run} &= (44,000 \times 0.591)/12 \\ &= 2,167 \text{ lb-ft/ft} \\ r_{ru} &= 4(2M_{rup} + M_{run})/L^2 \\ &= 4(2 \times 1,730 + 2,167)/(4.5)^2 \\ &= 1,111.8 \text{ lb/ft}^2 \end{aligned}$$

- (6) Determine equivalent static stiffness:

$$\begin{aligned} K_{rE} &= r_{ru}/X_{rE} = EIr_{ru}/0.0062r_{ru}L^4 \\ &= (30 \times 10^6 \times 0.566)/[0.0062 \times (4.5)^4 \times 144] \\ &= 46,380.3 \text{ lb/ft} \end{aligned}$$

- (7) Compute the natural period of vibration for the 1-ft width of panel:

$$\begin{aligned} m &= w/g \\ &= (4.8 \times 10^6 \text{ lb})/32.2 \\ &= 0.15 \times 10^6 \text{ lb-ms}^2/\text{ft}. \end{aligned}$$

$$\begin{aligned} T_{\text{fn}} &= 2[\pi] (0.74 \times 0.15 \times 106/46,380.3)^{1/2} \\ &= 9.68 \text{ ms} \end{aligned}$$

- (8) Calculate B/r_{u}' and T/T_{fn} :

$$\begin{aligned} B &= p \\ &= 4.3 \times 144 \\ &= 619.2 \text{ lb/ft}^2 \end{aligned}$$

$$\begin{aligned} B/r_{\text{u}}' &= 619.2/1,111.8 \\ &= 0.56 \end{aligned}$$

$$\begin{aligned} T/T_{\text{fn}} &= 40/9.68 \\ &= 4.13 \end{aligned}$$

Entering Figure 6-7 of NAVFAC P-397 with these ratios:

$$[\mu] = 1.10 < 3.0 \quad \text{O.K.}$$

- (9) Check maximum deflection and rotation.

$$\begin{aligned} X_{\text{E}} &= r_{\text{u}}'/K_{\text{E}} \\ &= 1,111.8/46,380.3 \\ &= 0.024 \text{ ft} \end{aligned}$$

$$\begin{aligned} X_{\text{m}} &= [\mu]X_{\text{E}} \\ &= 1.10 \times 0.024 \\ &= .026 \text{ ft} \end{aligned}$$

$$\begin{aligned} \tan [\theta] &= X_{\text{m}}/(L/2) \\ &= 0.026/2.25 \\ &= 0.012 \end{aligned}$$

$$[\theta] = 0.69 < 2.0 \quad \text{O.K.}$$

- (10) Check resistance in rebound:

From Figure 41, required $r_{\text{L}}'/r_{\text{u}}' = 0.55$

$$\begin{aligned} r_{\text{L}}' &= 0.55 \times 111.8 \\ &= 611.5 \text{ lb/ft}^2 \quad (\text{neglect small dead load}) \end{aligned}$$

Available maximum elastic resistance in rebound:

$$\begin{aligned} \text{Calculate } r_{\text{L}}' &= 4(2 \times 2167 + 1730)/(4.5)^2 \\ &= 1197.8 \text{ lb/ft}^2 > 611.5 \end{aligned}$$

(11) Check resistance in shear.

Interior support (combined shear and bending).

Determine dynamic shear capacity of a 1-ft width of panel.

$$\begin{aligned} h &= (1.500 - 2t) \text{ where } t = 0.043 \text{ in} \\ &= 1.500 - 0.086 \\ &= 1.414 \text{ in} \end{aligned}$$

$$h/t = 1.414/0.043 = 33 > 30$$

$$F_{dv} = 10.80 \text{ ksi}$$

Total web area for 1-ft width of panel:

$$(8 \times h \times t)/2 = 4 \times 1.414 \times 0.043 = 0.243 \text{ in}^2/\text{ft}$$

$$V_p = 0.243 \times 10.84 = 2.63 \text{ kips/ft}$$

Determine maximum dynamic shear force:

The maximum shear at an interior support of a continuous panel is:

$$\begin{aligned} V &= 0.625 r_u L \\ &= 0.625 (1,111.8 \times 4.5) / 1000 \\ &= 3.127 \text{ k/ft.} \end{aligned}$$

$$V > V_p$$

$$\text{or } 3.127 > 2.630 \quad \text{No Good.}$$

Go back to Step 4 and choose another section.

c. Design of Beam Columns.

Problem: Design a beam column for axial load combined with bending about the strong axis.

Given:

- (1) Bending moment, M .
- (2) Axial load, P .
- (3) Shear, V .
- (4) Span length, L .
- (5) Unbraced lengths, l_{rx} and l_{ry} .
- (6) Properties of structural steel, F_y and E .

Solution:

- (1) Select a preliminary member size with a section modulus, S , such that:

$$S \geq M/F_{dy}$$

and b_f/t_f complies with the structural steel being used.

- (2) Calculate P_{fy} and the ratio P/P_{fy} . Determine the maximum allowable d/t_f ratio and compare it to that of the section chosen. If the allowable d/t_f ratio is less than that of the trial section, choose a new trial section.
- (3) Check the shear capacity of the web. Determine the web area, A_w , and the allowable dynamic shear stress, F_{dv} . Calculate the web shear capacity, V_p , and compare to the design shear, V . If inadequate, choose a new trial section and return to Step 2.
- (4) Determine the radii of gyration, r_x and r_y , and plastic section modulus, Z , of the trial section from the AISC Handbook.
- (5) Calculate the following quantities using the various design parameters:

- (a) Equivalent plastic resisting moment:

$$M_p = F_{dy} Z$$

- (b) Effective slenderness ratios, K^*l_x/r_x and K^*l_y/r_y . For the effective length factor, K , see Section 1.8 of the Commentary on the AISC Specification.
- (c) Allowable axial stress, F_a , corresponding to the larger value of K^*l/r .
- (d) Allowable moment, M_m , from Equation (109a) or (109b).
- (e) F'_{e} and "Euler" buckling load, P_e .
- (f) Plastic axial load, P_p , and ultimate axial load, P_u .
- (g) Coefficient, C_m , (Section 1.6.1, AISC Specification).
- (6) Using the quantities obtained in Step 5, the applied moment, M , and axial load, P , check the interaction formulas, Equations (107) and (108). Both formulas must be satisfied for the trial section to be adequate.

Calculation:

Given:

- (1) $M_{rx} = 115 \text{ k-ft}$
- (2) $M_{ry} = 0$
- (3) $P = 53.5 \text{ k}$
- (4) $V = 15.1 \text{ k}$
- (5) Span length, $L = 17'-0"$
- (6) Unbraced lengths, $*l_{rx} = 17'-0"$ and $*l_{ry} = 17'-0"$
- (7) ASTM A36 steel, $F_y = 36 \text{ ksi}$, and $c = 1.1$
 $F_{dy} = cF_y = 1.1(36) = 39.6 \text{ ksi}$

Solution:

- (1) $S = M_{rx} / F_{dy} = 115(12) / 39.6 = 34.8 \text{ in}^3$
 Try W12 x 35 ($S = 45.6 \text{ in}^3$)
 $d/t_w = 41.7$
 $b_f / 2t_f = 6.31 < 8.5 \text{ O.K.}$
- (2) $P_y = A F_y = 10.3(36) = 371 \text{ k}$
 $P/P_y = 53.5/371 = 0.14 < 0.27$
 $d/t_w = (412/F_y^{1/2}) [1 - 1.4(P/P_y)]$
 $= (412/36^{1/2}) [1 - 1.4(0.14)]$
 $= 55.2 > 41.7 \text{ O.K.}$
- (3) $V_p = F_{dv} A_w$
 $F_{dv} = 0.55F_y = 0.55(36) = 21.8 \text{ ksi}$
 $A_w = t_w (d - 2t_f) = 0.305(12.50 - 2(0.520))$
 $= 3.50 \text{ in}^2$
 $V_p = 21.8(3.50) = 76.3 \text{ k} > 15.1 \text{ k O.K.}$
- (4) $r_x = 5.25 \text{ in.}$ $r_y = 1.54 \text{ in.}$ $Z = 51.2 \text{ in}^3$
- (5) $M_p = F_y Z$
 $= 39.6(51.2 \times 1/12) = 169.0 \text{ ft-k}$
 $K = 0.75 \text{ (Section 1.8, Commentary on AISC Specification)}$

$$K \cdot l_{rx} / r_{rx} = 0.75(17 \times 12) / 5.25 = 29.1$$

$$K \cdot l_{ry} / r_{ry} = 0.75(17 \times 12) / 1.54 = 99.4$$

$$F_{ra} = 13.10 \text{ ksi for } K \cdot l_{ry} / r_{ry} = 99 \text{ and } F_{ry} = 36 \text{ ksi}$$

$$F_{ra} = (1.1)(13.10) = 14.41 \text{ for } F_{dy} = 39.6 \text{ ksi}$$

$$\begin{aligned} M_{mx} &= [1.07 - (1/r_{ry})(F_{dy})^{1/2} / 3160] M_{px} < / = M_{px} \\ &= [1.07 - (204/1.54)(39.6)^{1/2} / 3,160] 169.0 \\ &= 136.2 < 169.0 \text{ ft-k} \end{aligned}$$

$$\begin{aligned} F'_{rx} &= 12[\pi]^2 E / 23 (K \cdot l_{rx} / r_{rx})^2 \\ &= 12[\pi]^2 (29,000) / 23 (29.1)^2 = 176.3 \text{ ksi} \end{aligned}$$

$$P_{rx} = 23 A F'_{rx} / 12 = 23(10.3)(176.3) / 12 = 3,481 \text{ k}$$

$$P_{p} = F_{dy} A = 39.6(10.3) = 408 \text{ k}$$

$$P_{u} = 1.7 A F_{ra} = 1.7(10.3)(14.41) = 252 \text{ k}$$

$$C_{mx} = .85 \text{ (Section 1.6.1, AISC Specification).}$$

$$\begin{aligned} (6) \quad & P/P_u + C_{mx} M_x / (1 - P/P_{rx}) M_{mx} \\ & + C_{my} M_y / (1 - P/P_{ry}) M_{my} < / = 1 \\ & = 53.5/252 + 0.85(115) / (1 - 53.5/3,481) 136.2 \\ & = 0.212 + 0.729 = 0.941 < 1 \quad \text{O.K.} \end{aligned}$$

$$\begin{aligned} & P/P_p + M_x / 1.18 M_{px} + M_y / 1.18 M_{py} < / = 1 \\ & = 53.5/408 + 115/1.18(169) \\ & = 0.131 \times 0.577 = 0.708 < 1 \quad \text{O.K.} \end{aligned}$$

d. Design of Single-Story Rigid Frames for Pressure-Time Loading.

Problem: Design a single-story, multi-bay rigid frame subjected to a pressure-time loading.

Given:

- (1) Pressure-time loading.
- (2) Design criteria.
- (3) Structural configuration.
- (4) Properties of steel.

Solution:

- (1) Establish the ratio [alpha] between the design values of the horizontal and vertical blast loads.
- (2) Using the recommended dynamic load factors presented in Table 23, establish the magnitude of the equivalent static loads for:
 - (a) Local mechanism of the roof and blastward column, and
 - (b) Panel or combined mechanisms for the frame as a whole.
- (3) Using the general expressions for the possible collapse mechanisms from Table 22 and the loads from Step 2, assume values of the moment capacity ratios C and C_{r1} , and proceed to establish the required design plastic moment, M_{rp} , considering all possible mechanisms. In order to obtain a reasonably economical design, it is desirable to select C and C_{r1} , so that the least resistance (or the required value of M_{rp}) corresponds to a combined mechanism. This will normally require several tries with assumed values of C and C_{r1} .
- (4) Calculate the axial loads and shears in all members using the approximate methods.
- (5) Design each member as a beam-column, using ultimate strength design criteria.
- (6) Using the moments of inertia from Step 5, calculate the sidesway natural period using Table 10 and Equation (112). Enter Figure 6-7 of NAVFAC P-397 with the ratios of T/T_{N1} and B/R_{u1} , and establish the ductility ratio, $[\mu]$. In this case, B/R_{u1} is the reciprocal of the panel or the sidesway mechanism dynamic load factor used in the trial design. Multiply the ductility ratio by the elastic deflection given by Equation (115) and establish the peak deflection X_{pm} from Equation (116). Compare the X_{pm}/H value with the criteria of paragraph 1.b.
- (7) Repeat the procedure of Step 6 for the local mechanism of the roof and blastward column. The stiffness and transformation factors may be obtained from Tables 7 and 10, respectively. The natural period is obtained from Equation (91). The resistance of the roof girder and the blastward column may be obtained from Table 22 using the values of M_{rp} and CM_{rp} determined in Step 3. Compare the ductility ratio and rotation with the criteria of paragraph 1.b.

- (8) (a) If the deflection criteria for both sidesway and beam mechanisms are satisfied, then the member sizes from Step 5 constitute the results of this preliminary design. These members would then be used in a more rigorous dynamic frame analysis such as the nonlinear dynamic computer program DYNFA (Section 8).
- (b) If the deflection criteria for a sidesway mechanism is exceeded, then the resistance of all or most of the members should be increased.
- (c) If the deflection criterion for a beam mechanism of the front wall or roof girder is exceeded, then the resistance of the member in question should be increased. The member sizes to be used in a final analysis should be the greater of these determined from Steps 8b and 8c.

Calculation:

Given:

- (1) Pressure-time loading as shown in Figure 50a.
- (2) Design criteria for reusable structure:
 For a frame, $[\delta] / H = 1/50$
 $[\theta]_{\max}$ for a frame member are summarized in paragraph 1.b (2) of this section.
- (3) Structural configuration as shown in Figure 50b
- (4) ASTM A36 steel.

Solution:

- (1) Determine $[\alpha]$:

$$b_{\Gamma h\gamma} = b_{\Gamma v\gamma} = 17 \text{ ft}$$

$$q_{\Gamma h\gamma} = 5.8 \times 17 \times 12 = 1,183 \text{ lb/in}$$

$$q_{\Gamma v\gamma} = 2.5 \times 17 \times 12 = 510 \text{ lb/in}$$

$$[\alpha] = q_{\Gamma h\gamma} / q_{\Gamma v\gamma} = 2.32$$

- (2) Establish equivalent static loads:

(a) Local beam mechanism, $w = \text{DLF} \times q_{\Gamma v\gamma}$

$$w = (1.0 \times 510 \times 12) / 1,000 = 6.12 \text{ k/ft.}$$

(b) Panel or combined mechanism, $w = \text{DLF} \times q_{\Gamma v\gamma}$

$$w = (0.5 \times 510 \times 12) / 1,000 = 3.06 \text{ k/ft}$$

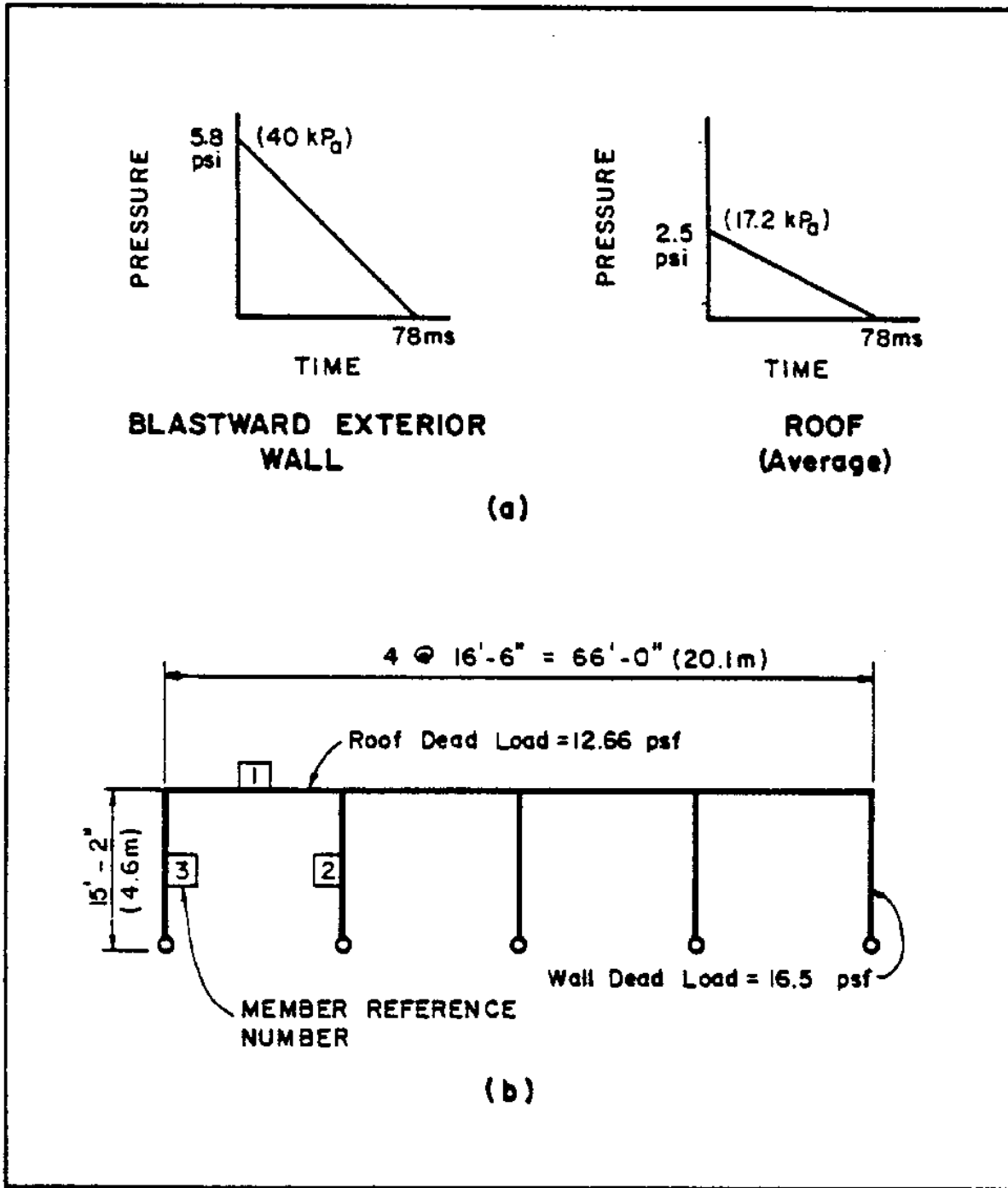

FIGURE 50

Preliminary Design of Four-Bay, Single-Story Rigid Frame

- (3) The required plastic moment capacities for the frame members are determined from Table 19, based upon rational assumptions for the moment capacity ratios C_{r1} and C . In general, the recommended starting values are C_{r1} equal to 2 and C greater than 2.

From Table 22, for $n = 4$, $[\alpha] = 2.32$.

$H = 15.167$ ft, $L = 16.5$ ft

and pinned bases, values of C_{r1} and C were substituted. After a few trials, the following solution is obtained:

$M_{rp} = 104$ k-ft, $C = 3.5$ and $C_{r1} = 2.0$.

The various collapse mechanisms and the associated values of M_{rp} are listed below:

<u>Collapse Mechanism</u>	<u>w (k/ft)</u>	<u>M_{rp} (k-ft)</u>
1	6.12	104
2	6.12	102
3a, 3b	3.06	102
4	3.06	103
5a, 5b	3.06	88
6	3.06	93

The plastic design moments for the frame members are established as follows:

Girder, $M_{rp} = 104$ k-ft

Interior column, $C_{r1}M_{rp} = 208$ k-ft

Exterior column, $CM_{rp} = 364$ k-ft

- (4) (a) Axial loads and shears due to horizontal blast pressure:

$w = 3.06$ k/ft

From Figure 45, $R_{ru} = [\alpha]wH$

$$= 2.32 \times 3.06 \times 15.167$$

$$= 108 \text{ kips}$$

(1) Member 1, axial load

$$P_1 = R_{\Gamma u_1} / 2 = 54 \text{ kips}$$

(2) Member 2, shear force

$$V_2 = R_{\Gamma u_1} / 2(4) = 108/8 = 13.5 \text{ kips}$$

(3) Member 3, shear force

$$V_3 = R_{\Gamma u_1} / 2 = 54 \text{ kips}$$

(b) Axial loads and shears due to vertical blast pressure:

$$w = 6.12 \text{ k/ft}$$

1. Member 1, shear force

$$V_1 = w \times L/2 = 6.12 \times 16.5/2 = 50.4 \text{ kips}$$

2. Member 2, axial load

$$P_2 = w \times L = 6.12 \times 16.5 = 101.0 \text{ kips}$$

3. Member 3, axial load

$$P_3 = w \times L/2 = 50.4 \text{ kips}$$

Note: Dead loads are small compared to blast loads and are neglected in this step.

(5) The members are designed using the criteria of Paragraph 5, with the following results:

Member	$M_{\Gamma P_1}$ (k-ft)	P (k)	V (k)	Use	$I_{\Gamma X_1}$ (in ⁴)
1	104	54.0	50.4	W12 x 35	285
2	208	101.0	13.6	W14 x 61	641
3	364	50.4	54.0	W14 x 82	882

(6) Determine the frame stiffness and sway deflection:

$$I_{\Gamma ca_1} = \frac{(3 \times 641) + (2 \times 882)}{5} = 737 \text{ in}^4$$

$$I_{\Gamma g_1} = 285 \text{ in}^4$$

$$[\text{beta}] = 0$$

$$D = \frac{I_{rg} / L}{0.75 I_{rc} / H} = \frac{285 / 16.5}{(0.75)(737 / 15.167)} = 0.475$$

Using linear interpolation to get C_{r2}

$$C_{r2} = 4.49$$

$$K = \frac{EI_{rc} C_{r2} [1 + (0.7 - 0.1)(n - 1)]}{H^3}$$

$$= \frac{(30)(10)^3 (737)(4.49)[1 + 0.7(3)]}{(15.157 \times 12)^3}$$

$$= 51.1 \text{ k/in}$$

$$K_{rL} = 0.55(1 - 0.25[\text{beta}]) = 0.55$$

Calculate dead weight, W:

Roof Dead Load	17' x 66' x 12.66 psf	= 14,204.5 lb
Roof Beam	66' x 35 lb/ft	= 2,310.0
Wall Dead Load	1/3(2 x 17' x 15.167' x 16.5 psf)	= 2,836.2
Exterior Columns	1/3(2 x 15.167' x 82 lb/ft)	= 829.1
Interior Columns	1/3(3 x 15.167' x 61 lb/ft)	= 925.2
Total		<u>W = 21,105.0 lb</u>

$$m_{re} = W/g = 21,105/32.2$$

$$= 655.4 \text{ lb-sec}^2/\text{ft or}$$

$$= 655.4 \times 10^6 \text{ lb-ms}^2/\text{ft}$$

$$T_{rN} = 2[\pi] (m_{re} / K K_{rL})^{1/2}$$

$$= 2[\pi] [655.4 \times 10^6 / (51.1 \times 12 \times 10^3 \times 0.55)]^{1/2}$$

$$= 277 \text{ ms}$$

$$T/T_{rN} = 78/277 = 0.282$$

$$B = 5.8 \times 17 \times 15.167 \times 144 = 215 \text{ k}$$

$$B/R_{ru} = 215/108 = 1.99$$

$$[\mu] = X_{rm} / X_{re} = 1.90$$

$$X_{re} = R_{ru} / K = [\alpha] wH / K$$

$$= \frac{2.32 \times 3.06 \times 15.167}{51.1} = 2.11 \text{ in}$$

$$X_{rm} = [\delta] = 1.90 \times 2.11 = 4.01 \text{ in}$$

$$[\delta] / H = 4.01 / (15.167)(12) = 0.0220 \text{ [esdot]} 1/50$$

(7) Check deflection of possible local mechanisms.

(a) Roof girder mechanism (investigate W12 x 35 from Step 5).

$$T_{rN} = 2 [\pi] (K_{rLM} m / K_{rE}) L^{1/2}$$

From Section 1 and Table 10

$$K_{rLM} = (.77 + .78)/4 + .66/2 = 0.72$$

$$\begin{aligned} m &= W/g = [(12.66 \times 17) + 35]/(32.2 \times 144) \\ &= 0.0539 \text{ lb-sec}^2/\text{in}^2 \text{ or} \\ &= 53,964 \text{ lb-ms}^2/\text{in}^2 \end{aligned}$$

$$\begin{aligned} K_{rE} &= 307EI/L^4 = 307 \times 30 \times 106 \times 285 / (16.5 \times 12)^4 \\ &= 1707.8 \text{ psi} \end{aligned}$$

$$T_{rN} = 2[\pi] (0.72 \times 53,964 / 1707.8) L^{1/2} = 30.0 \text{ ms}$$

$$T/T_{rN} = 78/30.0 = 2.60$$

$$r_{ru} = 16M_{rp}/L^2 = (16 \times 104)/16.52 = 6.11 \text{ k/ft.}$$

$$\begin{aligned} B &= pb \\ &= (2.5)(17)(144)/1,000 \\ &= 6.12 \text{ k} \end{aligned}$$

$$B/r_{ru} = 6.12/6.11 = 1.0$$

$$X_{rm}/X_{rE} = 3.40 > 3 \quad \text{N.G.}$$

Check end rotation of girder.

$$X_{rE} = r_{ru}/K_{rE} = 6.11/(1.71 \times 12) = 0.30 \text{ in}$$

$$K_{rm} = 3.40 \times 0.30 = 1.02 \text{ in}$$

$$\tan [\theta] = X_{rm}/(L/2) = 1.02/(8.25)(12) = 0.0103$$

$$[\theta] = 0.6\text{deg.} < 1\text{deg.} \quad \text{O.K.}$$

(b) Exterior column mechanism (investigate W14 x 82 from Step 5).

$$T_{rN} = 2[\pi] (K_{rLM} m / K_{rE}) L^{1/2}$$

From Section 1 and Table 10

$$K_{rLM} = (.78 + .78)/4 + 0.66/2 = 0.72$$

$$\begin{aligned}
 m &= [(16.5 \times 17) + 82] / (32.2 \times 144) \\
 &= 0.078 \text{ lb-sec}^2/\text{in}^2 \text{ or} \\
 &= 78,179 \text{ lb-ms}^2/\text{in}^2
 \end{aligned}$$

$$\begin{aligned}
 K_{rE} &= 160 EI/L^4 \\
 &= 160 \times 30 \times 10^6 \times 882 / (15.167 \times 12)^4 \\
 &= 3.858.2 \text{ psi}
 \end{aligned}$$

$$\begin{aligned}
 T_{rN} &= 2[\pi] (0.72 \times 78,179 / 3858.2)^{1/2} \\
 &= 24.0
 \end{aligned}$$

$$T/T_{rN} = 78/24.0 = 3.25$$

$$\begin{aligned}
 r_{ru} &= \frac{4M_{rp}}{H^2} = \frac{4(104)}{15.1672 \times 12} [(2 \times 3.5) + 1] \\
 &= 1.206 \text{ K/in.}
 \end{aligned}$$

$$B = 5.8 \times (17 \times 12) / 1000 = 1.183 \text{ k/in.}$$

$$B/r_{ru} = 1.183 / 1.206 = 0.98$$

$$[\mu] = X_{rm} / X_{rE} = 3.60 > 3 \quad \text{N.G.}$$

Check end rotation of columns.

$$X_{rE} = r_{ru} / K_{rE} = 1.206 / 3.858 = 0.313 \text{ in}$$

$$X_{rm} = 3.60 \times 0.313 = 1.13 \text{ in}$$

$$\tan [\theta] = X_{rm} / (L/2) = 1.13 / (7.58)(12) = 0.0124$$

$$[\theta] = 0.71 \text{deg.} < 1 \text{deg.} \quad \text{O.K.}$$

(8) (a) The deflections of the local mechanisms exceed the criteria. The sidesway deflection is acceptable.

(b) Roof girder:

$$[\mu] = 3.50 \text{ from Step 7; increase trial size from W12 x 35 to W12 x 40.}$$

(c) Front wall:

$$[\mu] = 3.60 \text{ from Step 7; increase trial size from W14 x 82 to W14 x 90.}$$

Summary: The member sizes to be used in a computer analysis are as follows:

<u>Member</u>	<u>Size</u>
1	W12 x 40
2	W14 x 61
3	W14 x 90

9. NOTATION.

- A - Gross area of section, in²
- A_{fb} - Cross-sectional area of tension bracing, in²
- A_{fw} - Area of web, in²
- b - Width of loaded area
- b_{ff} - Width of flange, in
- b_{fh} - Tributary width for horizontal loading, ft
- b_{fv} - Tributary width of vertical loading, ft
- B - Blast load, psi
- c - Dynamic increase factor
- C - Exterior column capacity coefficient
- C_{fb} - Bending coefficient
- C_{fc} - Column slenderness ratio
- C_{fmx} , C_{fmy} - Coefficients applied to bending terms in interaction formula
- C_{f1} - Interior column capacity coefficient
- C_{f2} - Coefficient for single-story, multi-bay frame stiffness factor
- d - Depth of section, in
- D - Coefficient indicating relative girder to column stiffness
- DLF - Dynamic load factor

E	-	Modulus of elasticity, psi
F	-	Maximum bending stress in member, ksi
F_{ra}	-	Axial compressive stress permitted in absence of bending moment, ksi
F_{rdv}	-	Dynamic yield stress in shear, ksi
F_{rdy}	-	Dynamic yield stress in flexure, ksi
F_{rex} , F_{rey}	-	Euler stress divided by safety factor, ksi
F_{rs}	-	Allowable static design stress, ksi
F_{ry}	-	Static yield stress, ksi
g	-	Acceleration due to gravity, ft/sec ²
h	-	Clear distance between flanges of sections
H	-	Story height, ft
I	-	Moment of inertia, in ⁴
I_{ca}	-	Average column moment of inertia, in ⁴
I_g	-	Moment of inertia of girder, in ⁴
K	-	Effective length factor Frame Stiffness, k/in
K_b	-	Horizontal stiffness of tension bracing
K_E	-	Equivalent elastic unit stiffness, k/ft or lb/ft
K_L	-	Load factor
K_{LM}	-	Load-Mass factor
K_M	-	Mass factor
*l	-	Distance between cross sections braced against twist or lateral displacement of the compression flange, in
*l _b	-	Actual unbraced length in pland of bending, in
*l _{cr}	-	Critical unbraced length adjacent to plastic hinges, in
*l _x , *l _y	-	Unbraced lengths in x- and y-axes respectively

L	-	Span length, ft Bay width, ft
L_{rb}	-	Length of bracing between supports, ft
m	-	Unit mass of panel, $k\text{-ms}^2/\text{ft}$ Number of braced bays
m_{re}	-	Equivalent lumped mass, $k\text{-ms}^2/\text{ft}$ or $\text{lb-ms}^2/\text{ft}$
M	-	The lesser of the moment at the ends of the unbraced segments
M_{re}	-	Total effective mass
M_{rx}, M_{ry}	-	Moments that can be resisted by the member in the absence of axial load, ft-kips
M_{rp}	-	Plastic moment capacity, kips-ft
M_{rx}, M_{ry}	-	Plastic bending capacities about the x- and y-axis respectively, kips-ft
M_{un}	-	Negative plastic moment, ft-lb or ft-lb/ft
M_{up}	-	Positive plastic moment, ft-lb or ft-lb/ft
M_x, M_y	-	Maximum applied moments about the x- and y-axis respectively, k-ft
n	-	Number of bays
N	-	Bearing length, in
P_h	-	Reflected blast pressure on front wall, psi
P_v	-	Blast overpressure on roof, psi
P	-	Applied axial compressive load, k
P_{rx}, P_{ry}	-	Euler buckling load in x- and y-axes respectively, k
P_{rp}	-	Dynamic plastic axial load, k
P_u	-	Ultimate strength of member in compression, k
P_y	-	Plastic axial load, kips
q_h	-	Peak horizontal load on rigid frame, lb/in
q_v	-	Peak vertical load on rigid frame, lb/in
Q_u	-	Ultimate support reaction, k

r_{fb}	-	Radius of gyration of bracing member, in
r_{fT}	-	Radius of gyration of a section comprising the compression flange plus 1/3 of the compression web area taken about an axis in the plane of the web, in
r_{fu}	-	Ultimate unit resistance, psi or lb/in
r_{fx}, r_{fy}	-	Radius of gyration in x- and y-axis, respectively, in
R_{fu}	-	Ultimate total resistance, k
S	-	Elastic section modulus, in ³
t	-	Sheet thickness, in
t_{ff}	-	Flange thickness, in
t_{fw}	-	Web thickness, in
T	-	Blast load duration, ms
T_{fN}	-	Natural period of vibration, ms
V	-	Support shear, k or lb
V_{fD}	-	Dynamic shear, k or lb
w	-	Weight per unit length, lb/ft or k/ft Load per unit area, psf
W	-	Total weight, lb
X_{fE}	-	Equivalent elastic deflection, in
X_{fm}	-	Maximum deflection, in
Z	-	Plastic section modulus, in ³
[alpha]	-	Ratio of total horizontal to vertical peak loading
[beta]	-	Base fixity factor
[gamma]	-	Angle between bracing member and a horizontal plane, degrees
[delta]	-	Relative sidesway deflection between stories
[theta] $_{fmax}$	-	Maximum end rotation
[mu] $_{fmax}$	-	Maximum ductility ratio

SECTION 5. OTHER STRUCTURAL MATERIALS

1. MASONRY.

a. Application. Masonry units are used primarily for wall construction. These units may be used for both exterior walls subjected to blast overpressures and interior walls subjected to inertial effects due to building motions. Basic variations in wall configurations may be related to the type of masonry unit such as brick, clay tile or solid and hollow concrete masonry units (CMU), and the manner in which these units are laid (running bond, stack bond, etc.), the number of wythes of units (single or double), and the basic lateral load-carrying mechanism (reinforced or non-reinforced, one or two-way elements).

(1) In addition to their inherent advantages with respect to fire protection, acoustical and thermal insulation, structural mass and resistance to flying debris, masonry walls when properly designed and detailed can provide economical resistance to relatively low blast pressures. However, the limitation on their application includes a limited capability for large deformations, reduced capacity in rebound due to tensile cracking in the primary phase of the response as well as the limitations on the amount and type of reinforcement which can be provided. Because of these limitations, masonry construction in this Manual is limited to concrete masonry unit (CMU) walls placed in a running bond and with single or multiple wythes. However, because of the difficulty in achieving the required interaction between the individual wythes, the use of multiple wythes should be avoided.

(2) Except for small structures (such as tool sheds, garages, etc.,) where the floor area of the building is relatively small and interconnecting block walls can function as shear walls, masonry walls will usually require supplementary framing to transmit the lateral forces produced by the blast forces to the building foundation. Supplementary framing is generally classified into two categories (depending on the type of construction used); namely flexible type supports such as structural steel framing and rigid supports including reinforced concrete frames or shear wall slab construction. The use of masonry walls in combination with structural steel frames is usually limited to incident overpressures of 2 psi or less while masonry walls when supported by rigid supports may be designed to resist incident pressures as high as 10 psi. Figures 51 and 52 illustrate these masonry support systems.

(3) Depending on the type of construction used, masonry walls may be classified into three categories: a) cavity walls, b) solid walls, and c) a combination of cavity and solid walls. The cavity walls utilize hollow load-bearing concrete masonry units conforming to ASTM C90. Solid walls use solid load-bearing concrete masonry units conforming to ASTM C145 or hollow units whose cells and voids are filled with grout. The combined cavity and solid walls utilize the combination of hollow and solid units. Masonry walls may be subdivided further depending on the type load-carrying mechanism desired: a) joint reinforced masonry construction, b) combined joint and cell reinforced masonry construction, and c) non-reinforced masonry construction.

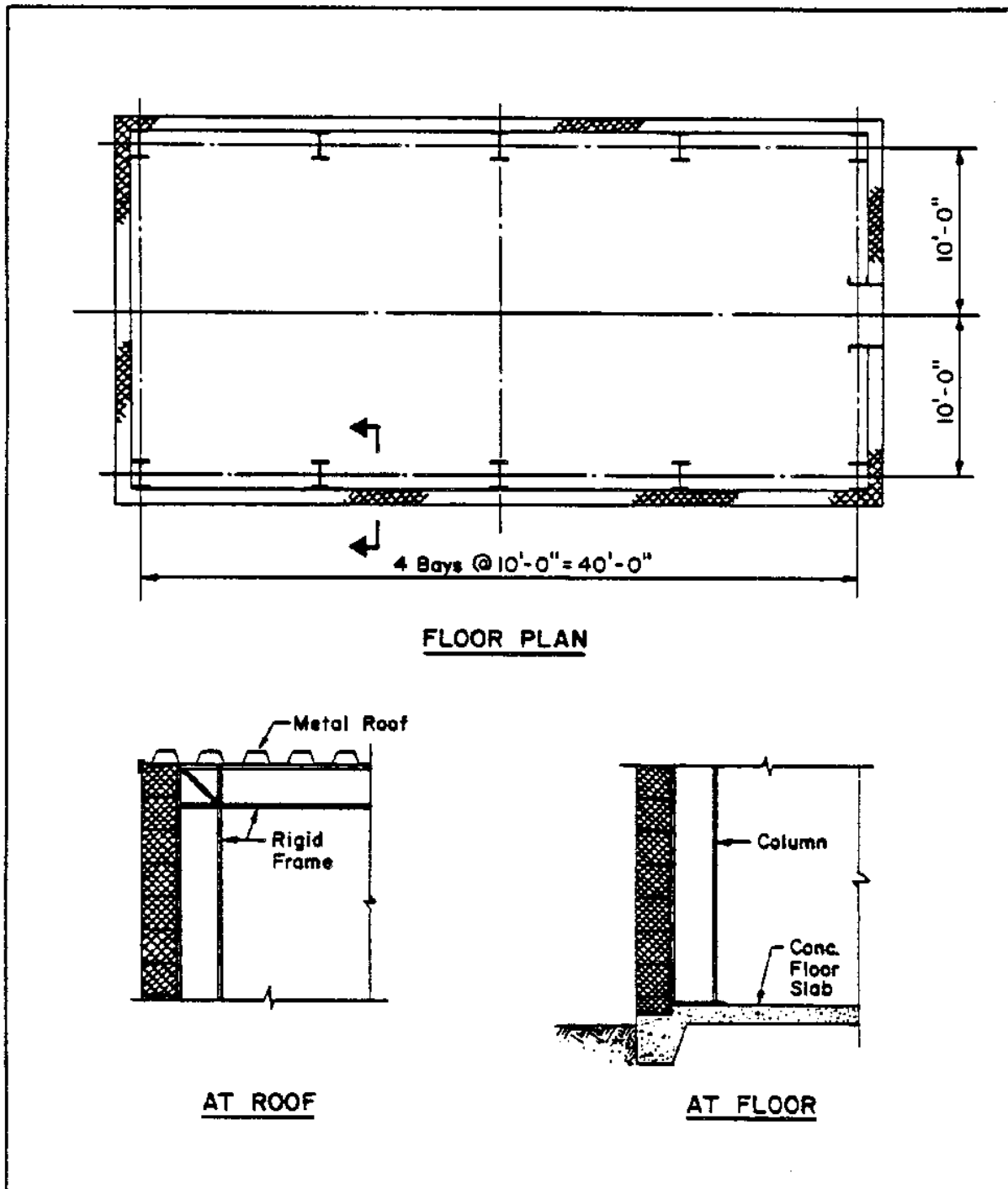

FIGURE 51
Masonry Wall With Flexible Support

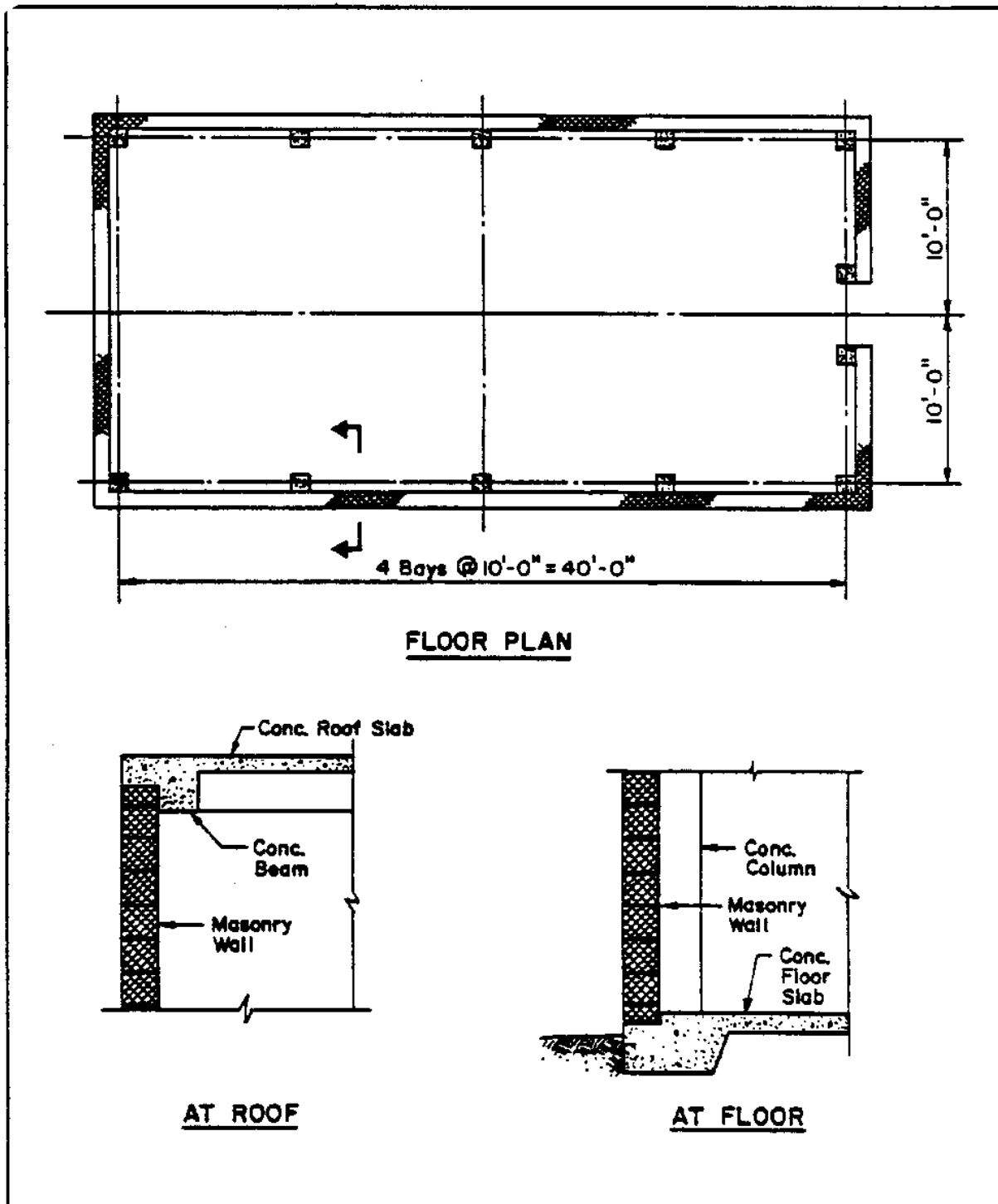

FIGURE 52
Masonry Wall With Rigid Support

(a) Joint reinforced masonry construction consists of single or multiple wythe walls and utilizes either hollow or solid masonry units. The joint reinforced wall construction utilizes commercially available cold drawn wire assemblies (see Figure 53), which are placed in the bed joints between the rows of the masonry units. Two types of reinforcement are available; truss and ladder types. The truss reinforcement provides the more rigid system and, therefore, is recommended for use in blast resistance structures. In the event that double wythes are used, each wythe must be reinforced independently. The wythes must also be tied together using wire ties. Joint reinforced masonry construction is generally used in combination with flexible type supports. The cells of the units located at the wall supports must be filled with grout. Typical joint reinforced masonry construction is illustrated in Figure 54.

(b) Combined joint and cell reinforcement masonry construction consists of single wythe walls which utilize both horizontal and vertical reinforcement. The horizontal reinforcement may consist either of the joint reinforcement previously discussed or reinforcing bars. Where reinforcing bars are used, special masonry units are used which permit the reinforcement to sit below the joint (Figure 55). The vertical reinforcement consists of reinforcing bars which are positioned in one or more of the masonry units cells. All cells, which contain reinforcing bars, must be filled with grout. Depending on the amount of reinforcement used, this type of construction may be used with either the flexible or rigid type support systems.

(c) Non-reinforced masonry construction consists of single wythe of hollow or solid masonry units. This type of construction does not utilize reinforcement for strength but solely relies on the arching action of the masonry units formed by the wall deflection and support resistance (Figure 55). This form of construction is utilized with the rigid type support system and, in particular, the shear wall and slab construction system.

b. Design Criteria for Reinforced Masonry Walls

(1) Static Capacity of Reinforced Masonry Units. Figure 56 illustrates typical shapes and sizes of concrete masonry units which are commercially available. Hollow masonry units shall conform to ASTM C90, Grade N. This grade is recommended for use in exterior below and above grade and for interior walls. The minimum dimensions of the components of hollow masonry units are given in Table 27.

(a) The specific compressive strength ($f'_{m\eta}$) for concrete masonry units may be taken as:

<u>Type of Unit</u>	<u>Ultimate Strength ($f'_{m\eta}$)</u>
Hollow Units	1350 psi
Hollow Units filled with grout	1500 psi
Solid Units	1800 psi

while the modulus of elasticity, $E_{m\eta}$, of masonry units is equal to:

EQUATION:
$$E_{m\eta} = 1000 f'_{m\eta} \quad (125)$$

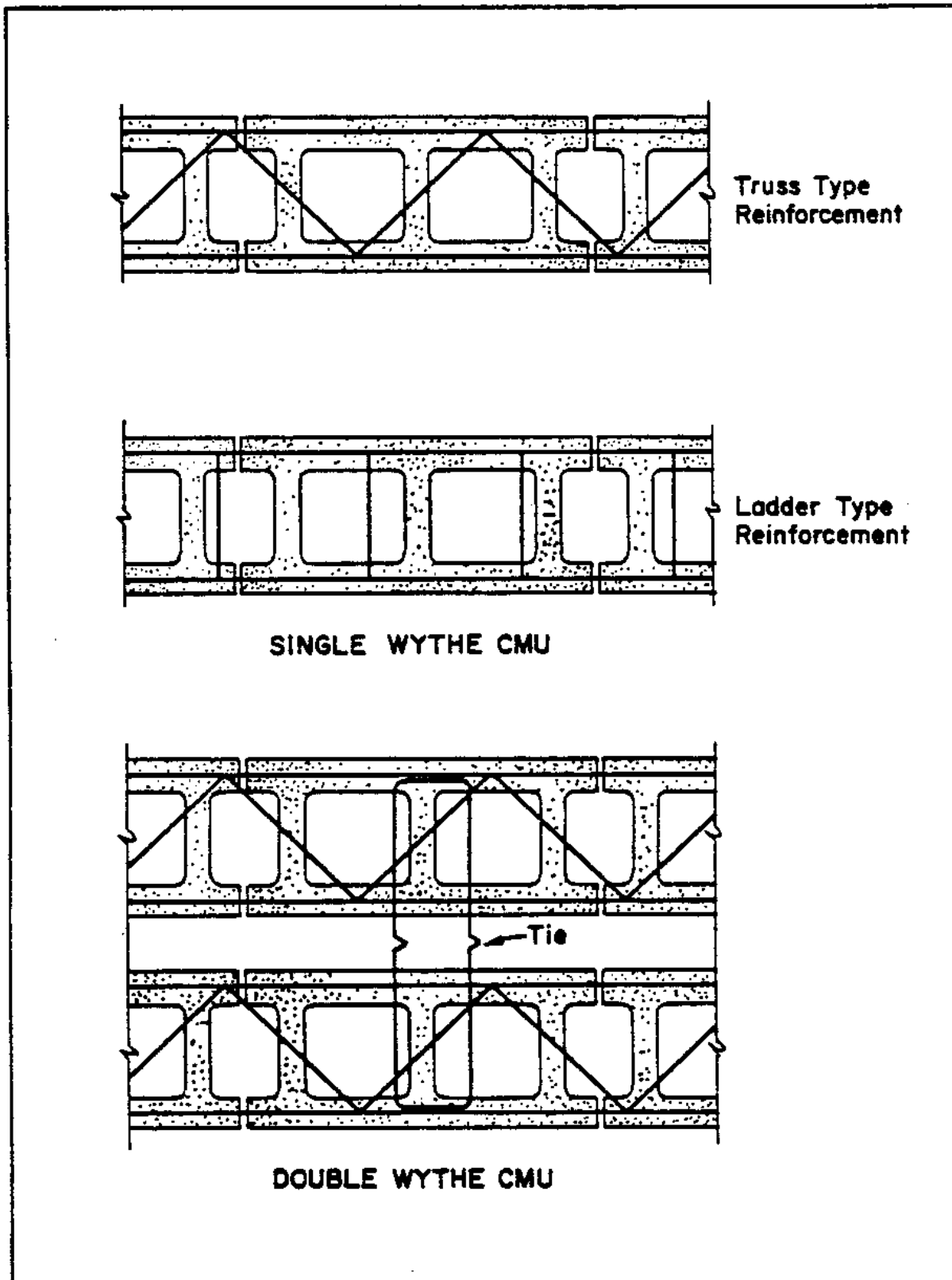
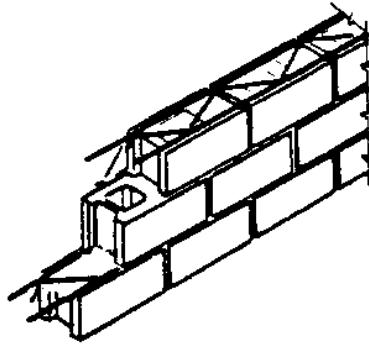
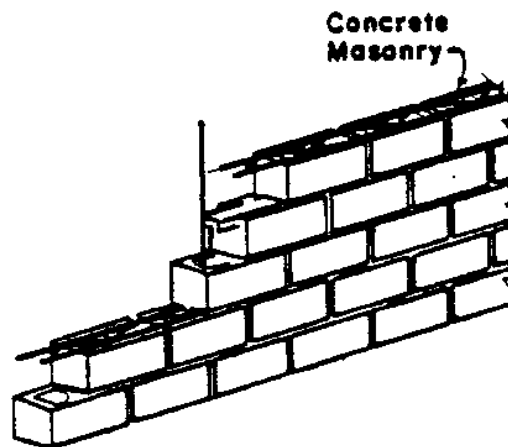

FIGURE 53
Concrete Masonry Walls



JOINT REINFORCED MASONRY CONSTRUCTION



COMBINED JOINT AND CELL REINFORCED
MASONRY CONSTRUCTION

FIGURE 54

Typical Joint Reinforced Masonry Construction

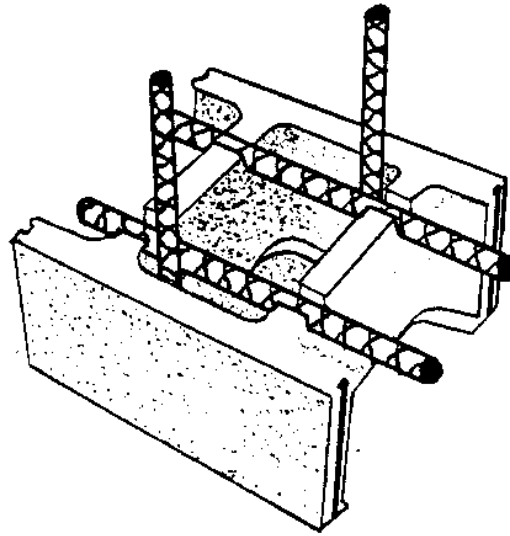

REINFORCED MASONRY UNIT

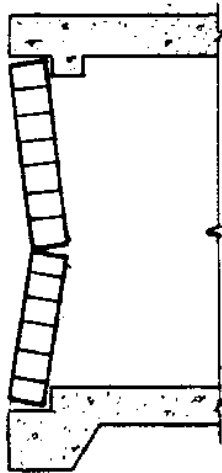

NON - REINFORCED MASONRY CONSTRUCTION

FIGURE 55

Reinforced vs Non-Reinforced Masonry Construction

2.08-203

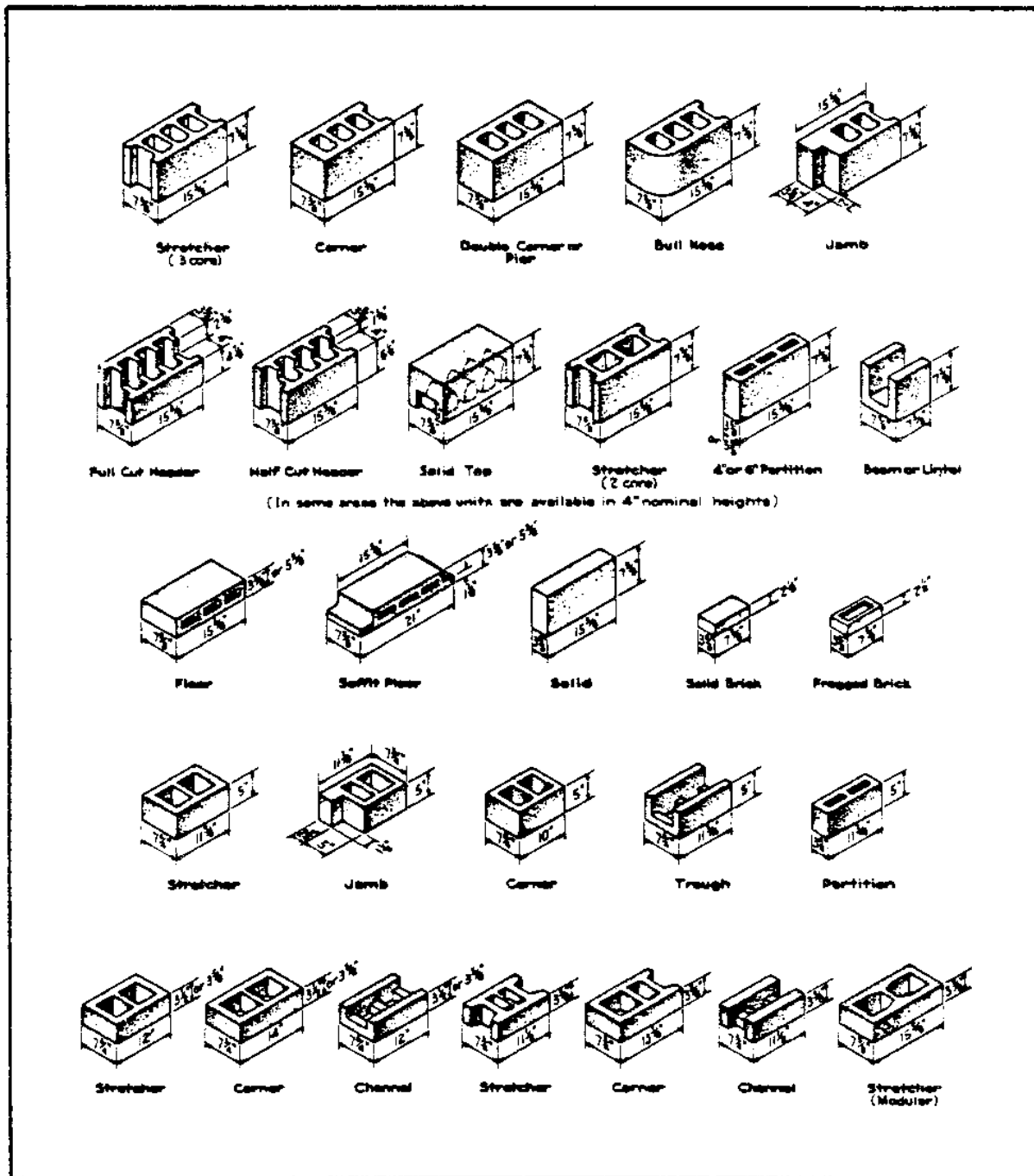

FIGURE 56
Typical Concrete Masonry Units

Table 27
Properties of Hollow Masonry Units

Nominal Width of Units (in)	Face-Shell Thickness (in)	Equiv. Web Thickness (in)
3 and 4	0.75	1.625
6	1.00	2.25
8	1.25	2.25
10	1.375	2.50
12	1.500	2.50

2.08-205

The specific compressive strength and the modulus of elasticity of the mortar may be assumed to be equal to that of the unit.

(b) Joint reinforcement shall conform to the requirements of ASTM A82 and, therefore, it will have a minimum ultimate (f_{ru}) and yield (f_{ry}) stresses equal to 80 ksi and 70 ksi respectively. Reinforcing bars shall conform to ASTM A615 (Grade 60) and have minimum ultimate stress (f_{ru}) of 90 ksi and minimum yield stress (f_{ry}) of 60 ksi. The modulus of elasticity of the reinforcement is equal to 29,000,000 psi.

(2) Dynamic Strength of Material. Since design for blast resistant structures is based on ultimate strength, the actual yield stresses of the material, rather than conventional design stresses or specific minimum yield stresses, are used for determining the plastic strengths of members. Further, under the rapid rates of straining that occur in structures loaded by blast forces, materials develop higher strengths than they do in the case of statically loaded members. In calculating the dynamic properties of concrete masonry construction, it is recommended that the dynamic increase factor be applied to the static yield strengths of the various components as follows:

Concrete

Compression, axial or flexure	1.25 f'_{cm}
Shear	1.00 f'_{cm}

Reinforcement

Compression, axial or flexure	1.10 f_{ry}
-------------------------------	---------------

(3) Ultimate Strength of Reinforced Concrete Masonry Walls.

(a) The ultimate moment capacity of joint reinforced masonry construction may be conservatively estimated by utilizing the horizontal reinforcement only and neglecting the compressive strength afforded by the concrete. That is the reinforcement in one face will develop the tension forces while the steel in the opposite face resists the compression stresses. The ultimate moment relationship may be expressed for each horizontal joint of the wall as follows:

$$\text{EQUATION:} \quad M_{ru} = A_{rs} f_{r dy} d_{rb} \quad (126)$$

where,

- A_{rs} = area of joint reinforcement at one face, in²
- $f_{r dy}$ = dynamic yield strength of the joint reinforcement, psi
- d_{rb} = distance between the centroids of the compression and tension reinforcement, in
- M_{ru} = ultimate moment capacity, in-lb/joint

On the contrary, the ultimate moment capacity of the cell reinforcement (vertical reinforcement) in a combined joint and cell reinforced masonry construction utilizes the concrete strength to resist the compression forces. The method of calculating ultimate moment of the vertical reinforcement is the same as that presented in the Section 5-1 and 5-2 of NAVFAC P-397 which is similar to that presented in the American Concrete Institute standard, Building Code Requirements for Reinforced Concrete.

(b) The ultimate shear stress in joint masonry walls is computed by the formula:

$$\text{EQUATION:} \quad v_{\tau u} = V_{\tau u} / A_{\tau n} \quad (127)$$

where,

$v_{\tau u}$ = unit shear stress, psi

$V_{\tau u}$ = total applied design shear at $d_{\tau b} / 2$ from the support, lb/in

$A_{\tau n}$ = net area of section, in²/in

In all cases, joint masonry walls, which are designed to resist blast pressures, shall utilize shear reinforcement which shall be designed to carry the total shear stress. Shear reinforcement shall consist of; (1) bars or stirrups perpendicular to the longitudinal reinforcement, (2) longitudinal bars bent so that the axis or inclined portion of the bent bar makes an angle of 45 degrees or more with the axis of the longitudinal part of the bar; or (3) a combination of (1) and (2) above. The area of the shear reinforcement placed perpendicular to the flexural steel shall be computed by the formula:

$$\text{EQUATION:} \quad A_{\tau v} = \frac{v_{\tau u} b s}{[\phi] f_{\tau y}} \quad (128)$$

where,

$A_{\tau v}$ = area of shear reinforcement, in²

b = unit width of wall, in

s = spacing between stirrups, in

$f_{\tau y}$ = yield stress of the shear reinforcement, psi

$[\phi]$ = strength reduction factor equal to .85

When bent or inclined bars are used, the area of shear reinforcement shall be calculated using:

$$\text{EQUATION:} \quad A_{\tau v} = \frac{V_{\tau u} b s}{[\phi] f_{\tau y} (\sin [\alpha] + \cos [\alpha])} \quad (129)$$

where α is the angle between inclined stirrup and longitudinal axis of the member.

Shear reinforcement in walls shall be spaced so that every 45 degree line extending from mid-depth ($d/2$) of a wall to the tension bars, crosses at least one line of shear reinforcement.

(c) Cell reinforced masonry walls essentially consist of solid concrete elements. Therefore, the relationships, for reinforced concrete as presented in Section 5-3 of NAVFAC P-397, may also be used to determine the ultimate shear stresses in cell reinforced masonry walls. Shear reinforcement for cell reinforced walls may only be added to the horizontal joint similar to joint reinforced masonry walls.

(4) Dynamic Analysis. The principles for dynamic analysis of the response of structural elements to blast loads are presented in Section 1 of this manual. These principles also apply to blast analyses of masonry walls. In order to perform these analyses, certain dynamic properties must be established as follows:

(a) Load-mass factors, for masonry walls spanning in either one direction (joint reinforced masonry construction) or two directions (combined joint and cell reinforced masonry construction) are the same as those load-mass factors which are listed for reinforced concrete elements of Section 6-6 of NAVFAC P-397. The load-mass factors are applied to the actual mass of the wall. The weights of masonry wall can be determined based on the properties of hollow masonry units previously described and utilizing a concrete unit weight of 150 pounds per cubic foot. The values of the load-mass factors, K_{LM} , will depend in part on the range of behavior of the wall; i.e., elastic, elasto-plastic, and plastic ranges. An average value of the elastic and elasto-plastic value of K_{LM} is used for the elasto-plastic range, while an average value of the average K_{LM} for the elasto-plastic range and K_{LM} of the plastic range is used for the wall behavior in the plastic range.

(b) The resistance-deflection function is illustrated in Figure 2. This figure illustrates the various ranges of behavior previously discussed and defines the relationship between the wall's resistances and deflections as well as presents the stiffness, K , in each range of behavior. It may be noted in Figure 2, that the elastic and elasto-plastic ranges of behavior have been idealized forming a bilinear (or trilinear) function. The equations for defining these functions are presented in Section 5-16 of NAVFAC P-397.

(c) The ultimate resistance, r_u , of a wall varies with a) the distribution of the applied load, b) the geometry of the wall (length and width), c) the amount and distribution of the reinforcement, and d) the number and type of supports. The ultimate resistances of both one- and two-way spanning walls are given in Section 5-10 of NAVFAC P-397.

(d) Recommended maximum deflection criteria for masonry walls subjected to blast loads is presented in Table 28. This table includes criteria for both reusable and non-reusable conditions as well as criteria for both one- and two-way spanning walls.

Table 28
Deflection Criteria for Masonry Walls

Wall Type	Support Type	Support Rotation
Reusable	One-way	0.5deg.
	Two-way	1.0deg.
Non-Reusable	One-way	1.0deg.
	Two-way	2.0deg.

(e) When designing masonry walls for blast loads using response chart procedures of Section 1, the effective natural period of vibration is required. This effective period of vibration when related to the duration of the blast loading of given intensity and a given resistance of the masonry wall determines the maximum transient deflection, X_{Tm} , of the wall. The expression for the natural period of vibration is presented in Equation (1), Section 1, where the effective unit mass, m_{Te} , has been described previously and the equivalent unit stiffness, K_{Te} , is obtained from the resistance-deflection function. The equivalent stiffness of one-way beams is presented in Table 7 which may be used for one-way spanning walls except that a unit width shall be used. Methods for determining the stiffness and period of vibrations for two-way walls are presented in Section 6-8 of NAVFAC P-397.

(f) Determining the stiffness in the elastic and elasto-plastic range is complicated by the fact that the moment of inertia of the cross section along the masonry wall changes continually as cracking progresses, and further by the fact that the modulus of elasticity changes as the stress increases. It is recommended that computations for deflections and therefore, stiffnesses be based on average moments of inertia, I_{Ta} , as follows:

$$\text{EQUATION:} \quad I_{Ta} = \frac{I_{Tn} + I_{Tc}}{2} \quad (130)$$

where,

I_{Tn} = the moment of inertia of the net section, in⁴

I_{Tc} = the moment of inertia of the cracked section, in⁴

For solid masonry units the value of I_{rn} is replaced with the moment of inertia of the gross section. The values of I_{rn} and I_{rg} for hollow and solid masonry units used in joint reinforced masonry construction are listed in Table 29. The values of I_{rg} for solid units may also be used for walls which utilize combined joint and cell masonry construction. The values of I_{rc} for both hollow and solid masonry construction may be obtained using:

$$\text{EQUATION:} \quad I_{rc} = 0.005 \, b d^3 \, \rho_b \quad (131)$$

(5) Rebound. Vibratory action of a masonry wall will result in negative deflections after the maximum positive deflection has been attained. This negative deflection is associated with negative forces which will require tension reinforcement to be positioned at the opposite side of the wall from the primary reinforcement. In addition, wall ties are required to assure that the wall is supported by the frame (see Figure 57). The rebound forces are a function of the maximum resistance of the wall as well as the vibratory properties of the wall and the load duration. The maximum elastic rebound of a masonry wall may be obtained from Figure 6-8 of NAVFAC P-397.

c. Non-Reinforced Masonry Walls. The resistance of non-reinforced masonry walls to lateral blast loads is a function of the wall deflection, mortar compression strength, and the rigidity of the supports.

(1) Rigid Supports. If the supports are completely rigid and the mortar's strength is known, a resistance function can be constructed in the following manner.

(a) Both supports are assumed to be completely rigid and lateral motion of the top and bottom of the wall is prevented. An incompletely filled joint is assumed to exist at the top as shown in Figure 58a. Under the action of the blast load the wall is assumed to crack at the center. Each half then rotates as a rigid body until the wall takes the position shown in Figure 58b. During the rotation the midpoint, m , has undergone a lateral motion, X_{rc} , in which no resistance to motion will be developed in the wall, and the upper corner of the wall (point o) will be just touching the upper support. The magnitude of X_{rc} can be found from the wall geometry in its deflected position:

$$\begin{aligned} \text{EQUATION:} \quad (T - X_{rc})^2 &= (L)^2 - [h/2 + (h' - h)/2]^2 \\ &= (L)^2 - (h'/2)^2 \end{aligned} \quad (132)$$

where the values of X_{rc} and L are given by:

$$\text{EQUATION:} \quad X_{rc} = T - [(L)^2 - (h'/2)^2]^{1/2} \quad (133)$$

and

$$\text{EQUATION:} \quad L = [(h/2)^2 + T^2]^{1/2} \quad (134)$$

All other symbols are shown in Figure 58.

Table 29
Moment of Inertia of Masonry Walls

Type of Unit	Width of Unit, in	Moment of Inertia, in ^{L4J}
Hollow Unit	3	2.0
	4	4.0
	6	12.7
	8	28.8
	10	51.6
	12	83.3
Solid Unit	3	2.7
	4	5.3
	6	18.0
	8	42.7
	10	83.0
	12	144.0

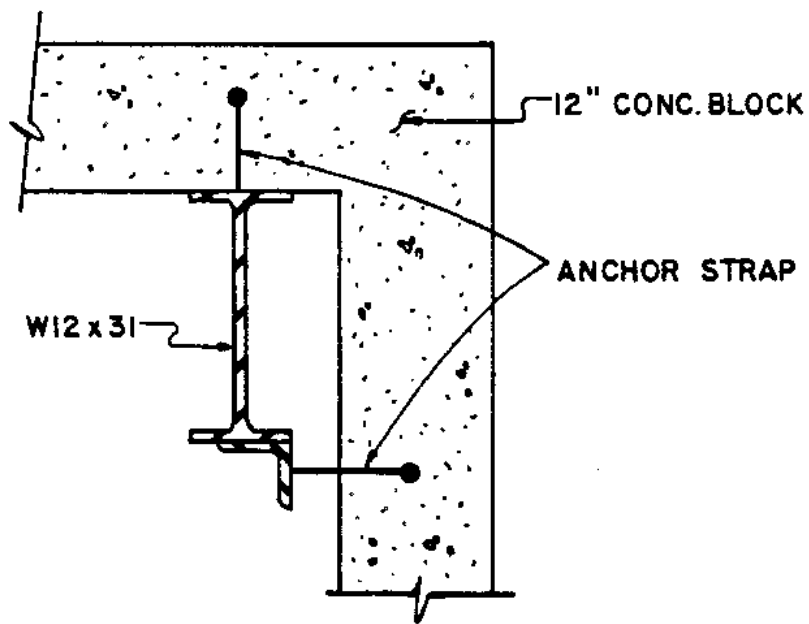

(a) Masonry Anchor Straps at Corners

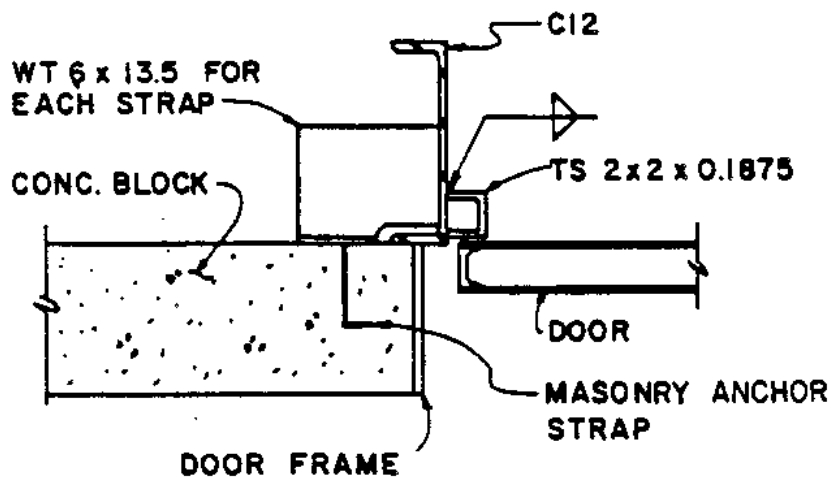

(b) Masonry Anchor Strap Detail at Door

FIGURE 57

Connection Details for Rebound and Negative Overpressures

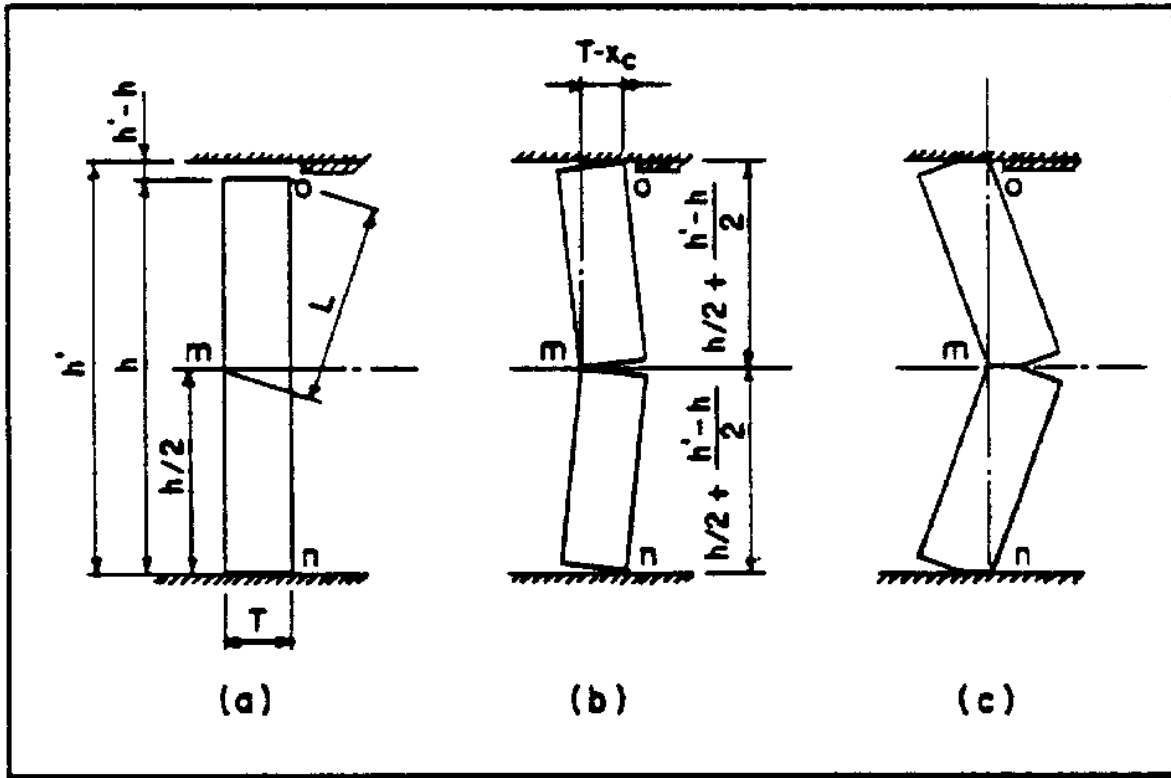

FIGURE 58

Deflection of Non-Reinforced Masonry Walls

2.08-213

(b) For any further lateral motion of point m, compressive forces will occur at points m and o. These compressive forces form a couple that produces a resistance to the lateral load equal to:

$$\text{EQUATION:} \quad r_{\Gamma u \gamma} = 8M_{\Gamma u \gamma} / h L^2 \quad (135)$$

where all symbols have previously been defined.

(c) When point m deflects laterally to a line n-o (Figure 58c), the moment arm of the resisting couple will be reduced to zero and the wall with no further resistance to deflection. In this position the diagonals om and mn will be shortened by an amount equal to $L - h'/2$

The unit strain in the wall caused by the shortening will be:

$$\text{EQUATION:} \quad [\text{epsilon}]_{\Gamma m \gamma} = (L - h'/2) / L \quad (136)$$

where,

$$[\text{epsilon}]_{\Gamma m \gamma} = \text{unit strain in the mortar, in/in}$$

All the shortening is assumed to occur in the mortar joints; therefore:

$$\text{EQUATION:} \quad f_{\Gamma m \gamma} = E_{\Gamma m \gamma} [\text{epsilon}]_{\Gamma m \gamma} \quad (137)$$

where,

$E_{\Gamma m \gamma}$ = modulus of elasticity of the mortar, psi

$f_{\Gamma m \gamma}$ = compressive stress corresponding to the strain $s[\text{epsilon}]_{\Gamma m \gamma}$, psi

In most cases $f_{\Gamma m \gamma}$ will be greater than the ultimate compressive strength of the mortar $f'_{\Gamma m \gamma}$, and therefore cannot exist. Since for walls of normal height and thickness each half of the wall undergoes a small rotation to obtain the position shown in Figure 58c, the shortening of the diagonals om and mn can be considered a linear function of the lateral displacement of point m. The deflection at maximum resistance, $X_{\Gamma l \gamma}$, at which a compressive stress, $f_{\Gamma m \gamma}$, exists at points m, n, and o can therefore be found from the following:

$$\text{EQUATIONS:} \quad \frac{X_{\Gamma l \gamma} - X_{\Gamma c \gamma}}{T - X_{\Gamma c \gamma}} = \frac{f'_{\Gamma m \gamma}}{f_{\Gamma m \gamma}} = \frac{f'_{\Gamma m \gamma}}{E_{\Gamma m \gamma} [\text{epsilon}]_{\Gamma m \gamma}} \quad (138a)$$

or

$$X_{\Gamma l \gamma} = \frac{(T - X_{\Gamma c \gamma}) f'_{\Gamma m \gamma}}{(E_{\Gamma m \gamma} [\text{epsilon}]_{\Gamma m \gamma})} + X_{\Gamma c \gamma} \quad (138b)$$

The resisting moment that is caused by a lateral deflection, $X_{r1\gamma}$, is found by assuming rectangular compression stress blocks exist at the supports (points o and n) and at the center (point m) as shown in Figure 59a. The bearing width, a , is chosen so that the moment, $M_{r1\gamma}$, is a maximum; that is, by differentiating $M_{r1\gamma}$ with respect to a and setting the derivative equal to zero. For a solid masonry unit this will result in:

$$\text{EQUATION:} \quad a = 0.5 (T - X_{r1\gamma}) \quad (139)$$

and the corresponding ultimate moment and resistance (Figure 59b) are equal to:

$$\text{EQUATION:} \quad M_{r1\gamma} = 0.25 f'_{rm\gamma} (T - X_{r1\gamma}) L^2 \quad (140)$$

and

$$\text{EQUATION:} \quad r_{r1\gamma} = (2/h L^2) f'_{rm\gamma} (T - X_{r1\gamma}) L^2 \quad (141)$$

When the mid-span deflection is greater than $X_{r1\gamma}$ the expression for the resistance as a function of the displacement is:

$$\text{EQUATION:} \quad r = (2/h L^2) f'_{rm\gamma} (T - X) L^2 \quad (142)$$

As the deflection increases, the resistance is reduced until r is equal to zero and maximum deflection, $X_{rm\gamma}$, is reached (Figure 59b). Similar expressions can be derived for hollow masonry units. However, the maximum value of a cannot exceed the thickness of the flange width.

(2) Non-rigid Supports. For the case where the wall is supported by elastic supports at the top or bottom or both, the resistance curve cannot be constructed based on the value of the compression force, $af'_{rm\gamma}$, which is determined solely on geometry of the wall. Instead, the resistance curve is a function of the stiffness of the supports. Once the magnitude of the compression force is determined, equations similar to those derived for the case of the rigid supports can be used.

(3) Simply Supported Walls. If the supports offer no resistance to vertical motion, the compression in the wall will be limited by the wall weight above the floor plus any roof load which may be carried by the wall. If the wall carries no vertical loads, then the wall must be analyzed as a simply supported beam, the maximum resisting moment being determined by the modulus of rupture of the mortar.

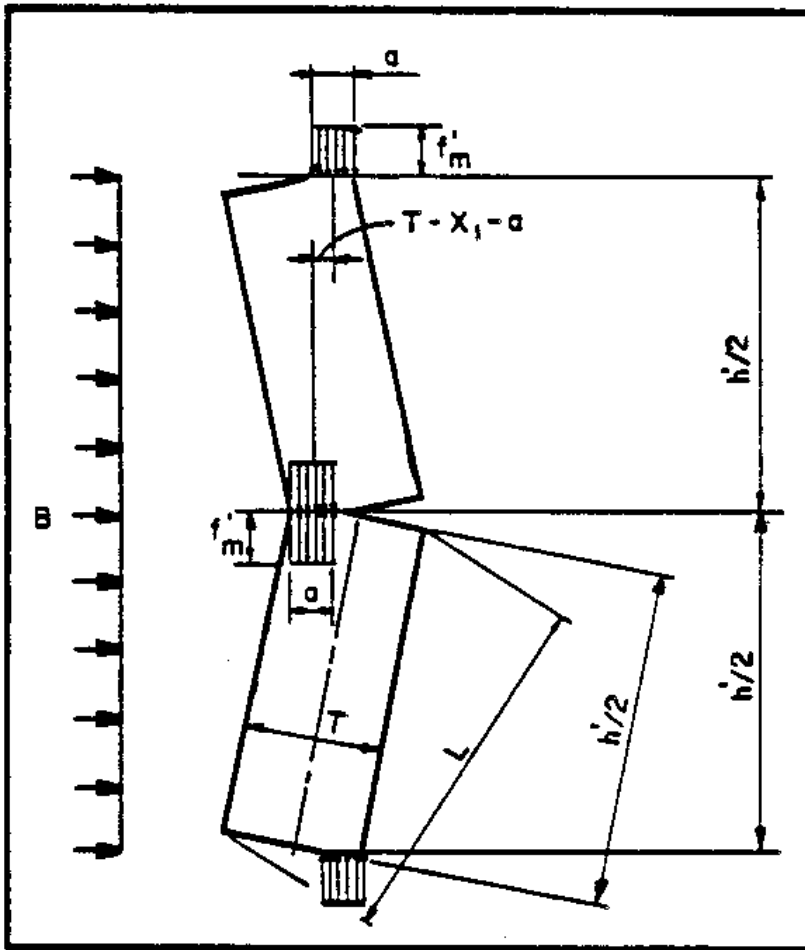

(a)

ARCHING BEHAVIOR

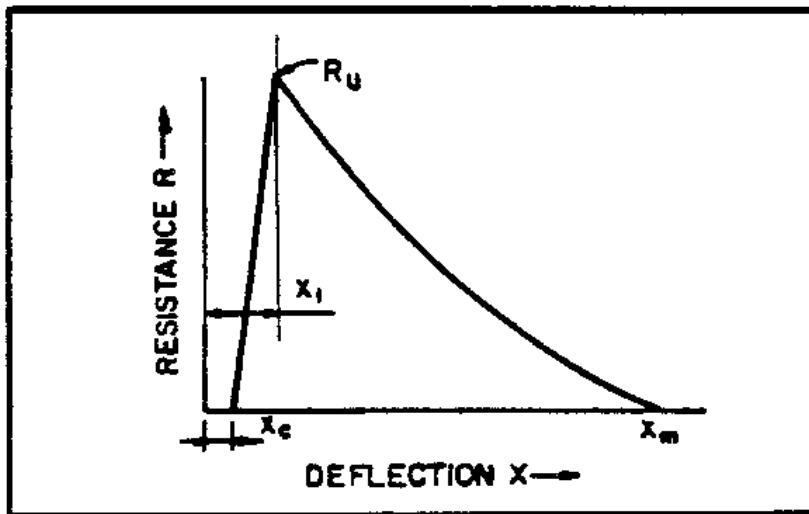

(b)

RESISTANCE - DEFLECTION FUNCTION

FIGURE 59
Structural Behavior of Non-Reinforced
Solid Masonry Panel with Rigid Supports

2. PRECAST CONCRETE.

a. Applications.

(1) Precast concrete construction can consist of either prestressed or conventionally reinforced members. Prestressing is advantageous in conventional construction, for members subjected to high flexural stresses such as long span or heavily loaded slabs and beams. Other advantages of precast concrete construction include: a) completion time for precast construction will be significantly less than the required for cast-in-place concrete, b) precast construction will provide protection against primary and secondary fragments not usually afforded by steel construction, and c) precast work is generally more economical than cast-in-place concrete construction especially when standard precast shapes can be used. The overriding disadvantage of precast construction is that the use of precast members is limited to buildings located at relatively low pressure levels of 1 to 2 psi. For slightly higher pressure levels, cast-in-place concrete or structural steel construction becomes the more economical means of construction. However, for even higher pressures, cast-in-place concrete is the only means available to economically withstand the applied load.

(2) Precast structures are of the shear wall type, rigid frame structures being economically impractical (see the discussion of connections, paragraph 2.g. below). Conventionally designed precast structures may be multi-story, but for blast design it is recommended that they be limited to single story buildings.

(3) Some of the most common precast sections are shown in Figure 60. The single tee and double tee sections are used for wall panels and roof panels. All the other sections are beam and girder elements. In addition, a modified flat slab section will be used as a wall panel around door openings. All of the sections shown can be prestressed or conventionally reinforced. In general though, for blast design, beams and roof panels are prestressed, while columns and wall panels are not. For conventional design, prestressing wall panels and columns is advantageous in tall multi-story buildings, and thus of no benefit for blast resistant design which uses only single story buildings. In fact, in the design of a wall panel the blast load is from the opposite direction of conventional loads and hence prestressing a wall panel decreases rather than increases the capacity of section.

b. Static Strength of Materials.

(1) Concrete. Generally, the minimum compressive strength of the concrete, f'_c , used in precast elements is 4000 to 5000 psi. High early-strength cement is usually used in prestressed element to ensure adequate concrete strength is developed before the prestress is introduced.

(2) Reinforcing Bars. Steel reinforcing bars are used for rebound and shear reinforcement in prestressed members as well as for flexural reinforcement in non-prestressed members. For use in blast design, bars designated by the American Society for Testing and Materials (ASTM) as A615, grade 60, are recommended. As only small deflections are permitted in precast members, the reinforcement is not stressed into its strain hardening region and thus the static design strength of the reinforcement is equal to its yield stress, $f_y = 60,000$ psi.

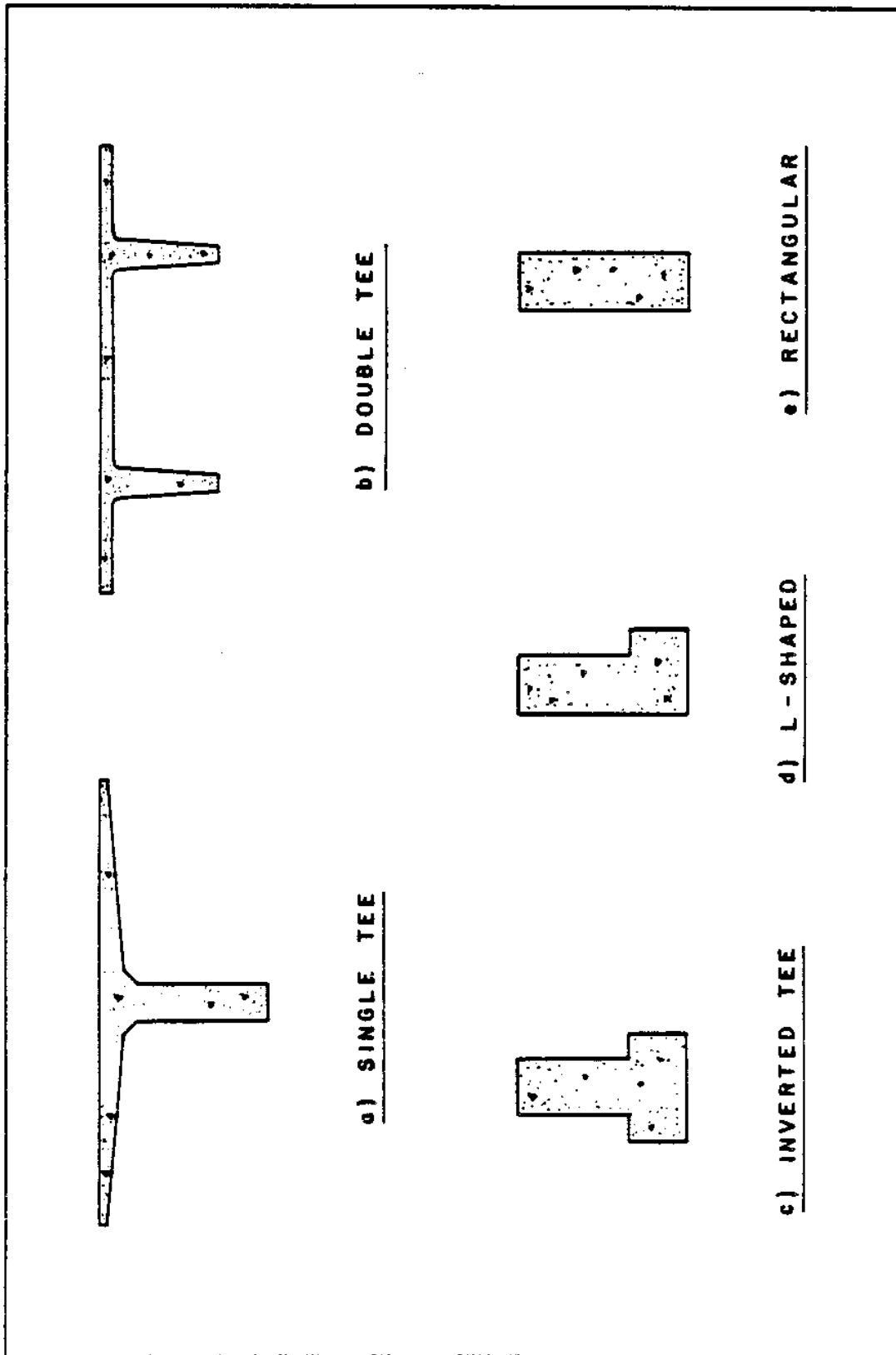

FIGURE 60
Common Precast Elements

(3) Welded Wire Fabric. Welded wire fabric, designated as A185 by ASTM, is used to reinforce the flanges of tee and double tee sections. In conventional design, welded wire fabric is sometimes used as shear reinforcement, but it is not used for blast design which requires closed ties. The static design strength, f_{ry} , of welded wire fabric is equal to its yield stress, 65,000 psi.

(4) Prestressing Tendons. There are several types of reinforcement that can be used in prestressing tendons. They are designated by ASTM as A416, A421, or A722, with A416, grade 250 or grade 270, being the most common. The high strength steel used in these types of reinforcement can only undergo a maximum elongation of 3.5 to 4 percent of the original length before the ultimate strength is reached. Furthermore, the high strength steel lacks a well defined yield point, but rather exhibits a slow continuous yielding with a curved stress-strain relationship until ultimate strength is developed (see Figure 61). ASTM specifies a fictitious yield stress, f_{py} , corresponding to a 1 percent elongation. The minimum value of f_{py} depends on the ASTM designation, but it ranges from 80 to 90 percent of the ultimate strength, f_{pu} .

c. Dynamic Strength of Materials. Under the rapid rate of straining of blast loads, most materials develop higher strengths than they do when statically loaded. An exception is the high strength steel used in prestressing tendons. Researchers have found that there was very little increase in the upper yield stress and ultimate tensile strengths of high strength steels under dynamic loading. The dynamic design strength is obtained by multiplying the static design strength by the appropriate dynamic increase factor, DIF, which is as follows:

(1) Concrete:

Compression	DIF = 1.25
Diagonal tension	DIF = 1.00
Direct shear	DIF = 1.10
Bond	DIF = 1.00

(2) Non-Prestressed Steel Reinforcement:

Flexure	DIF = 1.10
Shear	DIF = 1.00

(3) Welded Wire Fabric: DIF = 1.10

(4) Prestressed Reinforcement: DIF = 1.00

d. Ultimate Strength of Precast Elements. The ultimate strength of non-prestressed precast members is exactly the same as cast-in-place concrete members and as such is not repeated here. For the ultimate strength of beams and columns see paragraphs 3 and 4 respectively of Section 3 of this manual. For the ultimate strength of slabs see Chapter 5 of NAVFAC P-397.

(1) Ultimate Dynamic Moment Capacity of Prestressed Beams. The ultimate dynamic moment capacity M_{du} of a prestressed rectangular beam (or of a flanged section where the thickness of the compression flange is greater than or equal to the depth of the equivalent rectangular stress block, a , is as follows:

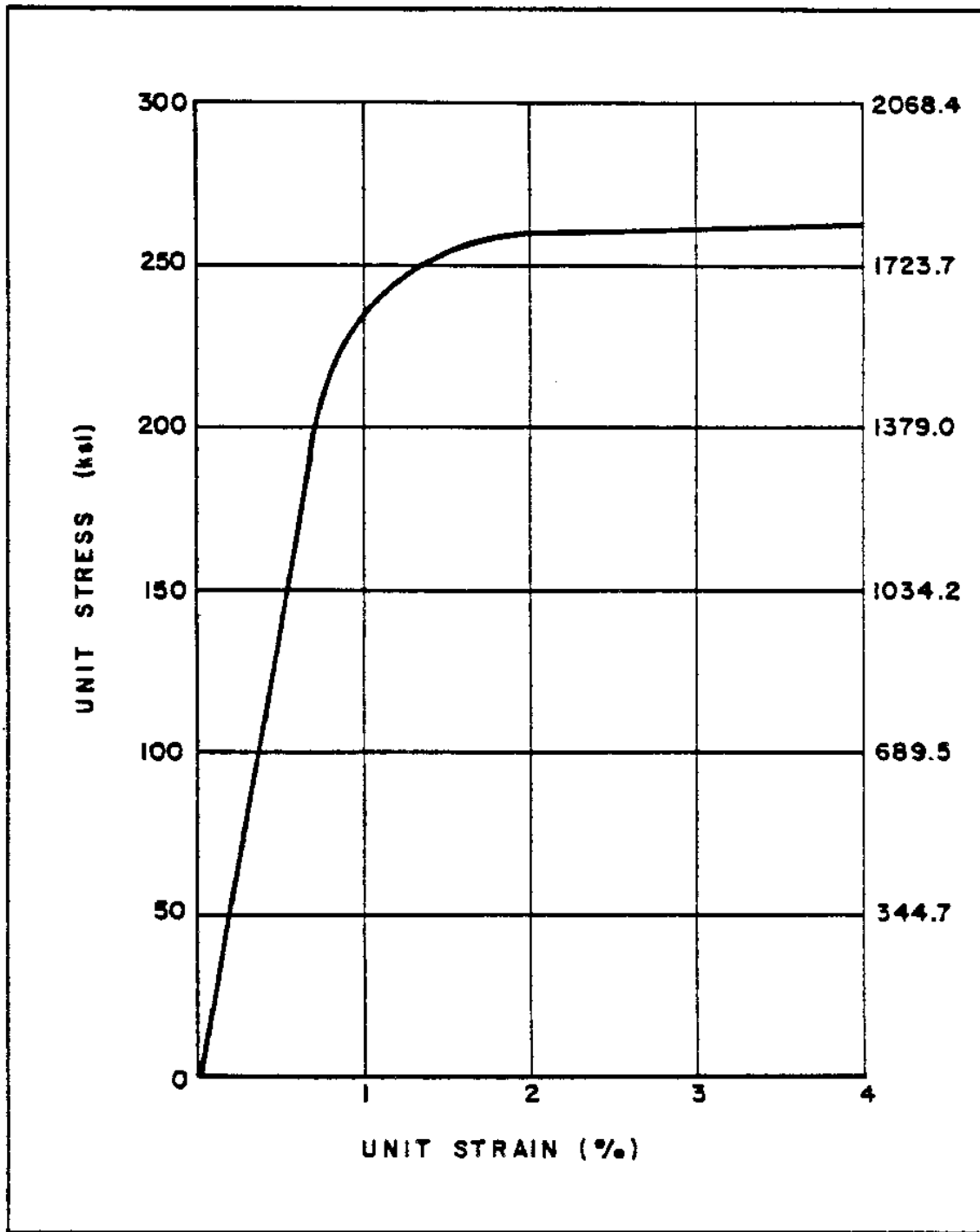

FIGURE 61
Typical Stress - Strain Curve for High Strength Wire

$$\text{EQUATION: } M_{\text{pu}} = A_{\text{ps}} f_{\text{ps}} (d_{\text{p}} - a/2) + A_{\text{s}} f_{\text{dy}} (d - a/2) \quad (143)$$

and

$$\text{EQUATION: } a = (A_{\text{ps}} f_{\text{ps}} + A_{\text{s}} f_{\text{dy}}) / .85 f'_{\text{dc}} b \quad (144)$$

where,

- M_{pu} = ultimate moment capacity, in-lb
- A_{ps} = total area of prestress reinforcement, in²
- f_{ps} = average stress in the prestressed reinforcement at ultimate load, psi
- d_{p} = distance from extreme compression fiber to the centroid of the prestressed reinforcement, in
- a = depth of equivalent rectangular stress block, in
- A_{s} = total area of non-prestressed tension reinforcement, in²
- f_{dy} = dynamic design strength of non-prestressed reinforcement, psi
- d = distance from extreme compression fiber to the centroid of the non-prestressed reinforcement, in
- f'_{dc} = dynamic compressive strength of concrete, psi
- b = width of the beam for a rectangular section or width of the compression flange for a flanged section, in

(a) The average stress in the prestressed reinforcement at ultimate load, f_{ps} , must be determined from a trial-and-error, stress-strain compatibility analysis. This may be tedious and difficult especially if the specific stress-strain curve of the steel being used is unavailable. In lieu of such a detailed analysis, the equations below may be used to obtain an appropriate value of f_{ps} .

For members with bonded prestressing tendons: (145)

$$\text{EQUATION: } f_{\text{ps}} = f_{\text{pu}} \left[\frac{1 - [\text{UPSILON}]_p [p_{\text{p}} \frac{L_{\text{pu}}}{f'_{\text{dc}}} + \frac{L_{\text{dy}}}{d_{\text{p}} f'_{\text{dc}}} (p - p')]}{K_1} \right]$$

where,

- f_{pu} = specified tensile strength of prestressing tendon, psi
- $[\text{UPSILON}]_p$ = factor for type of prestressing tendon
 - = 0.40 for $0.80 < f_{\text{py}}/f_{\text{pu}} < 0.90$
 - = 0.28 for $f_{\text{py}}/f_{\text{pu}} \geq 0.90$

f_{py} = "fictitious" yield stress of prestressing tendon corresponding to a 1 percent elongation, psi

K_1 = 0.85 for f'_{dc} up to 4000 psi and is reduced 0.05 for each 1000 psi in excess of 4000 psi

p_{p} = $A_{\text{ps}}/bd_{\text{p}}$, the prestressed reinforcement ratio

p = A'_{s}/bd , the ratio of non-prestressed tension reinforcement

p' = A'_{s}/bd , the ratio of compression reinforcement

A'_{s} = total area of compression reinforcement, in²

If any compression reinforcement is taken into account when calculating f_{ps} then the distance from the extreme compression fiber to the centroid of the compression reinforcement must be less than $0.15d_p$ and

$$[p_p f_{pu} / f'_{dc} + (f_{dy} / d_p f'_{dc}) (p - p')] \geq 0.17$$

If there is no compression reinforcement and no non-prestressed tension reinforcement, Equation (145) becomes:

$$\text{EQUATION; } f_{ps} = f_{pu} [1 - ([\text{UPSILON}]_p / K_{r1}) p_p (f_{pu} / f'_{dc})] \quad (146)$$

For members with unbonded prestressing tendons and a span-to-depth ratio less than or equal to 35:

$$\text{EQUATIONS: } f_{ps} = f_{se} + 10,000 + f'_{dc} / (100 p_p) \leq f_{py} \quad (147a)$$

and

$$f_{ps} \leq f_{se} + 60,000 \quad (147b)$$

where,

f_{se} = effective stress in prestressed reinforcement after allowances for all prestress losses, psi

For members with unbonded prestressing tendons and a span-to-depth ratio greater than 35:

$$\text{EQUATIONS: } f_{ps} = f_{se} + 10,000 + f'_{dc} / (300 p_p) \leq f_{py} \quad (148a)$$

and

$$f_{ps} \leq f_{se} + 30,000 \quad (148b)$$

(b) To insure against sudden compression failure the reinforcement ratios for a rectangular beam, or for a flanged section where the thickness of the compression flange is greater than or equal to the depth of the equivalent rectangular stress block will be such that:

$$\text{EQUATION: } p_p f_{ps} / f'_{dc} + (d f_{dy} / d_p f'_{dc}) (p - p') \leq 0.36 K_{r1} \quad (149)$$

When the thickness of the compression flange of a flanged section is less than the depth of the equivalent rectangular stress block, the reinforcement ratios will be such that:

$$\text{EQUATION: } \left(\frac{p_f p_w f_{ps}}{f'_c d} \right) + \left(\frac{df_{dy}}{d} \frac{p_f f'_c}{d} \right) (p_f w - p' w) < / = 0.36 K_1 \quad (150)$$

where $p_f p_w$, $p_f w$, $p' w$ are the reinforcement ratios for flanged sections computed as for p_f , p and p' , respectively, except that b shall be the width of the web and the reinforcement area will be that required to develop the compressive strength of the web only.

(2) Diagonal Tension and Direct Shear of Prestressed Elements. Under conventional service loads, prestressed elements remain almost entirely in compression, and hence are permitted a higher concrete shear stress than non-prestressed elements. However, at ultimate loads the effect of prestress is lost and thus no increase in shear capacity is permitted. The shear capacity of a precast beam may be calculated using the equations of paragraphs 3.d and 3.e of Section 3. The loss of the effect of prestress also means that d is the actual distance to the prestressing tendon and is not limited to $0.8h$ as it is in the ACI code. It is obvious then that at the supports of an element with draped tendons, d and thus the shear capacity are greatly reduced. Draped tendons also make it difficult to properly anchor shear reinforcement at the supports, exactly where it is needed most. Thus, it is recommended that only straight tendons be used for blast design.

e. Dynamic Analysis. The dynamic analysis of precast elements uses the procedures described in Chapters 5 and 6 of NAVFAC P-397 and Section 1 of this manual.

(1) Since precast elements are simply supported, the resistance-deflection curve is a one-step function (see Figure 34). The ultimate unit resistance for various loading conditions is presented in Table 5. As precast structures are subject to low blast pressures, the dead load of the structures become significant, and must be taken into account.

(2) The elastic stiffness of simply supported beams with various loading conditions is given in Table 7. In determining the stiffness, the effect of cracking is taken into account by using an average moment of inertia, I_{ra} , as given by Equation (76):

$$I_{ra} = (I_{rg} + I_{rc})/2$$

For non-prestressed elements, the cracked moment of inertia can be determined from Section 5-8 of NAVFAC P-397. For prestressed elements the moment of inertia of the cracked section may be approximated by:

$$\text{EQUATION: } I_{rc} = n A_{ps} d^2 \rho_f [1 - (p_f) L/2] \quad (151)$$

where n is the ratio of the modulus of elasticity of steel to concrete.

(3) The load-mass factors, used to convert the mass of the actual system to the equivalent mass, are given in Table 10. For prestressed elements the load-mass factor in the elastic range is used. An average of the elastic and plastic range load-mass factors is used in the design of non-prestressed elements.

(4) The equivalent single degree-of-freedom system is defined in terms of its ultimate resistance, $r_{\Gamma U \Gamma}$, equivalent elastic deflection $X_{\Gamma E \Gamma}$, and natural period of vibration, $T_{\Gamma N \Gamma}$. The dynamic load is defined by its peak pressure, B , and duration, T . For a triangular pulse load, Figure 6-7 of NAVFAC may be used to determine the response of an element in terms of its maximum deflection, $X_{\Gamma M \Gamma}$, and the time to reach maximum deflection, $t_{\Gamma M \Gamma}$.

(5) Recommended maximum deflection criteria for precast elements is as follows:

(a) For prestressed flexural members:

$[\theta]_{\Gamma \max \Gamma} < \neq 2 \text{deg.}$ or $[\mu]_{\Gamma \max \Gamma} < \neq 1$, whichever governs

(b) For non-prestressed flexural members:

$[\theta]_{\Gamma \max \Gamma} < \neq 2 \text{deg.}$ or $[\mu]_{\Gamma \max \Gamma} < \neq 3$, whichever governs

(c) For compression members:

$[\mu]_{\Gamma \max \Gamma} < \neq 1.3$

where $[\theta]_{\Gamma \max \Gamma}$ = maximum support ratio and $[\mu]_{\Gamma \max \Gamma}$ = maximum ductility ratio.

f. Rebound. Precast elements will vibrate under dynamic loads, causing negative deflections after the maximum deflection has been reached. The negative forces associated with these negative deflections may be predicted using Figure 6-8 of NAVFAC P-397.

(1) Non-prestressed elements. The design of non-prestressed precast elements for the effects of rebound is the same as for cast-in-place members. See paragraph 3.g. and 4.e. of Section 3 for a discussion of rebound effects in beams and columns respectively.

(2) Prestressed elements. In prestressed elements, non-prestressed reinforcement must be added to what is the compression zone during the loading phase to carry the tensile forces of the rebound phase. The rebound resistance will be determined from Figure 6-8 of NAVFAC P-397, but in no case will it be less than one-half of the resistance available to resist the blast load.

(a) The moment capacity of a precast element in rebound is as follows:

$$\text{EQUATION: } M_{ru} = A_s f_{dy} (d - a/2) \quad (152)$$

where,

- M_{ru} = ultimate moment capacity in rebound, in-lb
- A_s = total area of rebound tension reinforcement, in²
- f_{dy} = dynamic design strength of reinforcement, psi
- d = distance from extreme compression fiber to the centroid of the rebound reinforcement, in
- a = depth of the equivalent rectangular stress block, in

(b) It is important to take into account the compression in the concrete due to prestressing and reduce the strength available for rebound. For a conservative design, it may be assumed that the compression in the concrete due to prestressing is the maximum permitted by the ACI code, i.e., $0.45 f'_c$. Thus the concrete strength available for rebound is:

$$\text{EQUATION: } 0.85 f'_c - 0.45 f'_c = 0.85 f'_c - 0.45 f'_c / \text{DIF} = 0.49 f'_c \quad (153)$$

A more detailed analysis may be performed to determine the actual concrete compression due to prestress. In either case the maximum amount of rebound reinforcement added will be:

EQUATION:

$$A_s < / = [(0.85 f'_c - f) K_{rl} / f_{dy}] [(87000 - nf) bd - (87000 - nf + f_{dy})] \quad (154)$$

where f is the compression in the concrete due to prestressing and all the other terms have been defined previously.

If concrete compression is assumed to be $0.45 f'_c$, Equation (154) becomes:

$$\text{EQUATION: } A_s < / = \frac{(0.49 f'_c K_{rl} / f_{dy}) (87,000 - .36 n f'_c) bd}{(87,000 - 0.36 n f'_c + f_{dy})} \quad (155)$$

g. Connections. One of the fundamental differences between a cast-in-place concrete structure and one consisting of precast elements is the nature of connections between members. For precast concrete structures, as in the case of steel structures, connections can be detailed to transmit gravity loads only, gravity and lateral loads, or moments in addition to these loads. In general though, connectors of precast members should be designed so that blast loads are transmitted to supporting members through simple beam action. Moment-resisting connections for blast resistant structures would have to be quite heavy and expensive because of the relatively large rotations, and hence induced stresses, permitted in blast design.

(1) Detailed discussions and recommendations on the design of connections for precast concrete structures can be found in PCI publications, Design Handbook Precast Prestressed Concrete, Manual for Structural Design of Architectural Precast Concrete, and Manual on Design of Connections for Precast Prestressed Concrete. However, connections may require modification to account for the effects associated with the reversal stresses caused by rebound. Most of the connectors found in blast resistant design consist of seated connections and embedded steel plates which are connected by field welding "loose" steel plates or structural shapes to the embedded plates. Other standard PCI connections, such as bolt and insert connections and drilled-in-dowel connections are not recommended due to a lack of test data concerning their behavior under dynamic loading. These type of connections tend to fail because of concrete pullout and therefore lack the ductility required for blast design.

(2) In the design of connections the capacity reduction factor, $[\phi]$, for shear and bearing stresses on concrete are as prescribed by ACI code, 0.85 and 0.7 respectively. As recommended by NAVFAC P-397, no capacity reduction factor is used for moment calculations and no dynamic increase factors are used in determining the capacity of a connector. Capacity of the connection should be at least 10 percent greater than the reaction of the member being connected to account for the brittleness of the connection. In addition, the failure mechanism should be controlled by tension or bending stress of the steel, and therefore the pullout strength of the concrete and the strength of the welds should be greater than the steel strength.

(3) The following connections are standard for use in blast design but they are not intended to exclude other connection details. Other details are possible but they must be able to transmit gravity and blast loads, rebound loads, and lateral loads without inducing moments.

(a) Column-to-Foundation Connection. The standard PCI column-to-foundation connection may be used for blast design without modification. However, anchor bolts must be checked for tension due to rebound in order to prevent concrete pullout.

(b) Roof Slab-to-Girder Connection. Figure 62 shows the connection detail of a roof panel (tee section) framing into a ledger beam. The bearing pads transmit gravity loads while preventing the formation of moment couples. The bent plate, welded to the plate embedded in the flange of the tee, transmits lateral loads but is soft enough to deform when the roof panel tries to rotate. The angle welded to the embedded plate in the web of the tee restricts the panel, through shear action, from lifting off the girder during the rebound loading. The effects of dimensional changes due to creep, shrinkage, and relaxation of prestress should be considered in this type of connection.

(c) Wall Panel-to-Roof Slab Connection. The basic concepts employed in the roof slab-to-girder connection apply to the wall panel-to-roof slab connection shown in Figure 63. The roof panel instead of bearing on the girder, bears on a corbel cast with the tee section. The angle that transmits lateral loads has been moved from the underside of the flange to the top of the flange to facilitate field welding.

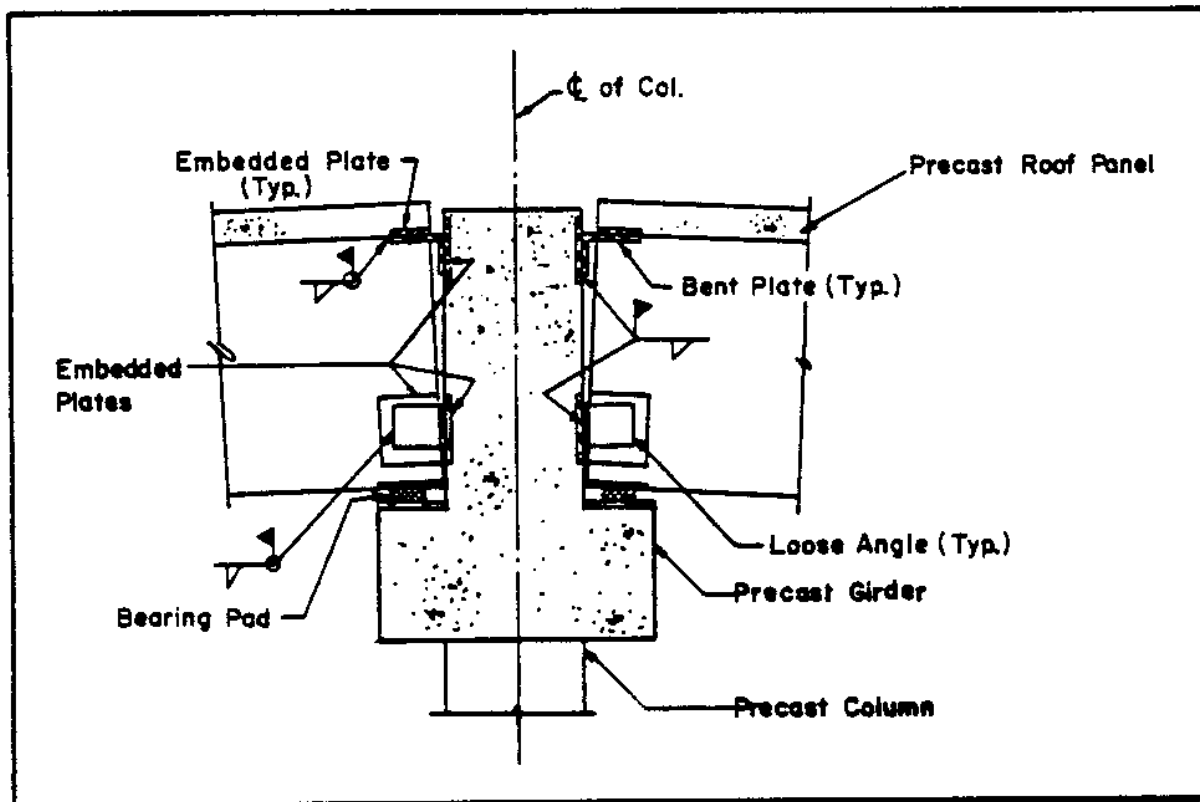

FIGURE 62
Typical Building Cross Section

2.08-227

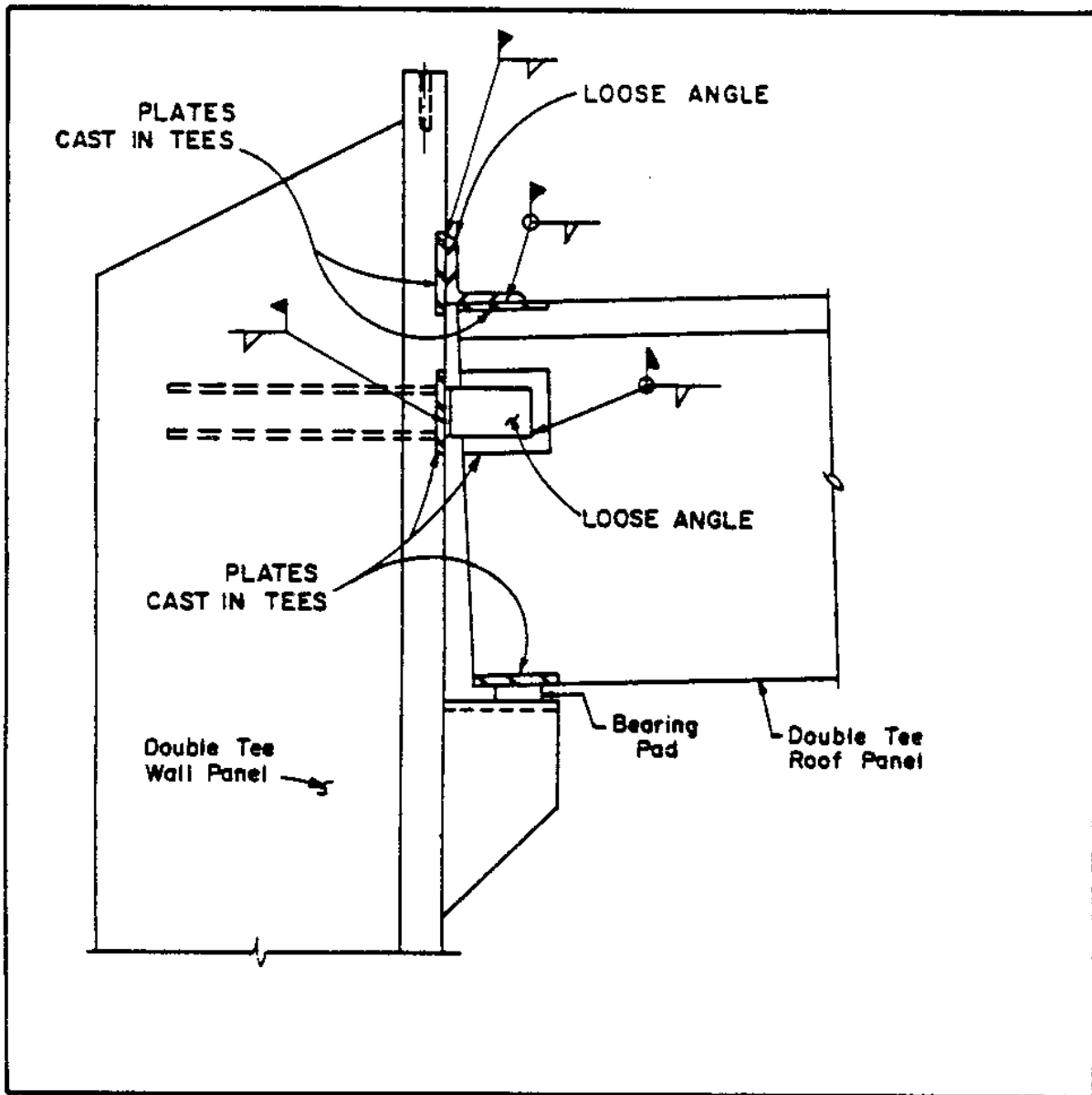

FIGURE 63
Typical Wall Panel - To - Roof Slab Connection

(d) Wall Panel-to-Foundation Connection. The wall panel in Figure 64 is attached to the foundation by means of angles welded to plates cast in both the wall panel and the foundation. It is essential to provide a method of attachment to the foundation that is capable of taking base shear in any direction, and also a method of levelling and aligning the wall panel. Non-shrinking grout is used to fill the gap between the panel and the foundation so as to transmit the loads to the foundation.

(e) Panel Splice. Since precast structures are of the shear wall type, all horizontal blast loads are transferred by diaphragm action, through wall and roof slabs to the foundations. The typical panel splice shown in Figure 65 is used for transferring the horizontal loads between panels.

(f) Reinforcement Around Door Openings. A standard double tee section cannot be used around a door opening. Instead, a special panel must be fabricated to satisfy the requirements for the door opening. The design of the reinforcement around the door opening and the door frame is discussed in paragraph 6.c of Section 6.

3. GLASS.

a. Types of Glass. Glass is primarily a product of the fusion of silica. The principal compounds added during manufacturing of window glass are soda to improve quality and lime to improve chemical durability. There are several types of glass, some of which are; sheet glass, polished plate glass, and tempered, laminated, or wire glass. Usually, in blast resistant structures, the type of glass found can be divided into two basic categories: (1) regular glass which is that glass used in normal home construction and (2) tempered glass which consists of regular glass whose properties have been proportionally controlled and has been rapidly cooled from near the softening point (annealed) to increase its mechanical and thermal endurance.

b. Properties of Glass. The properties of glass are presented in several literature, some of which are Response of Glass in Windows to Sonic Booms, by McKinley, Glass Engineering Handbook, by Shand, and The Mechanical Properties of Glass, by Preston. Glass, which is both homogeneous and isotropic, conforms to elastic theory up to the point of fracture; i.e., either fracture occurs or the specimen returns to its original shape on release of applied loads. It can be stated categorically that glass always fails in tension. Glass strength usually depends on flaws or defects most often found on the surface. Since glass does not yield (and is brittle), stress concentrations at flaws are not relieved and failure is caused by the propagation of one of the flaws. Other factors affecting strength are moisture, temperature, duration of stress, age and induced stresses. Values for material properties of glass can be found in the literature referenced above.

Typical values are:

Modulus of Elasticity, $E = 10^{17}$ psi

Poisson's ratio, $[\nu] = 0.23$

Unit weight, $W = 0.090 \text{ lb/in}^3$ or 155 lb/ft^3

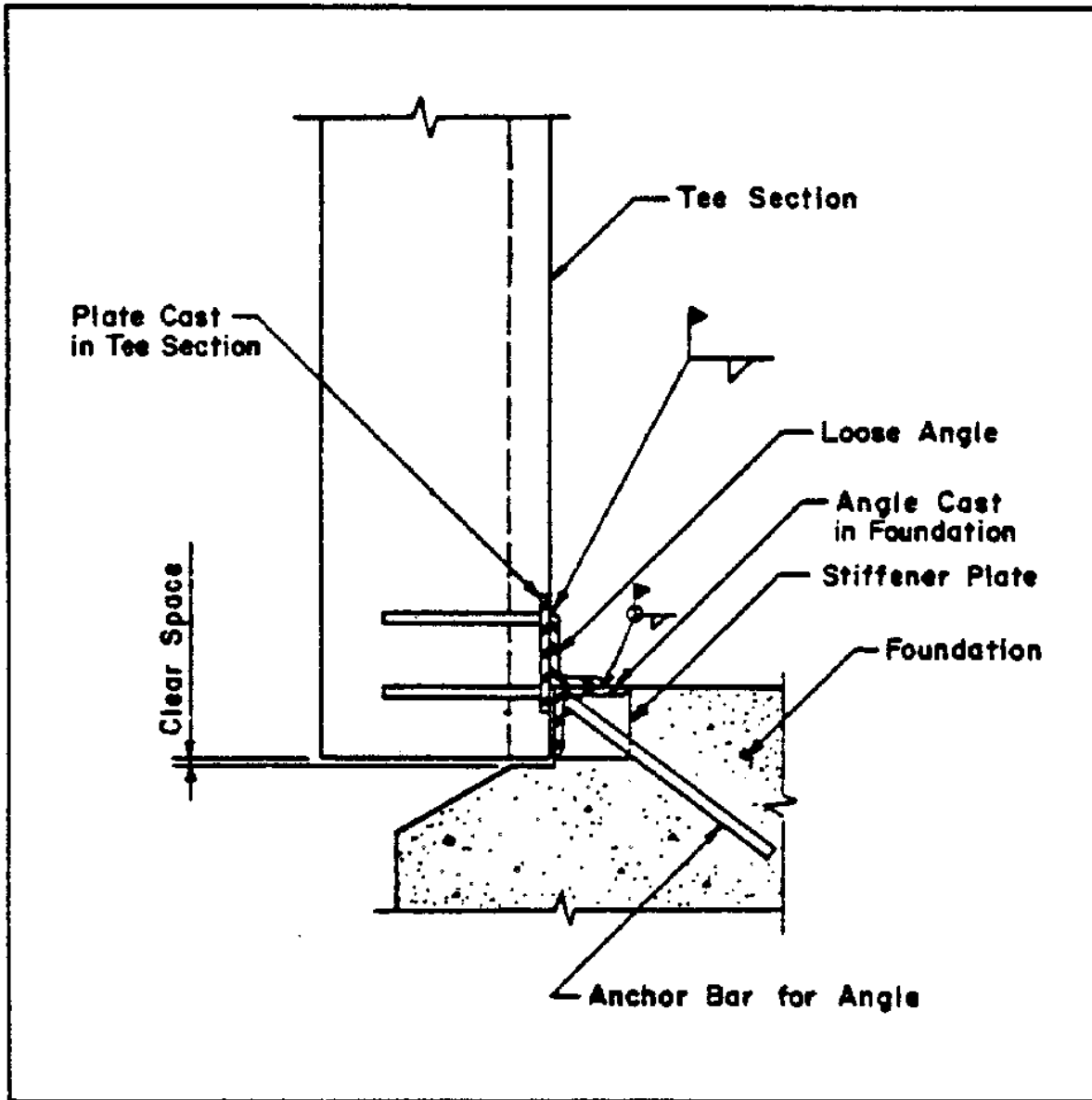

FIGURE 64
Wall Panel-to-Foundation Connection

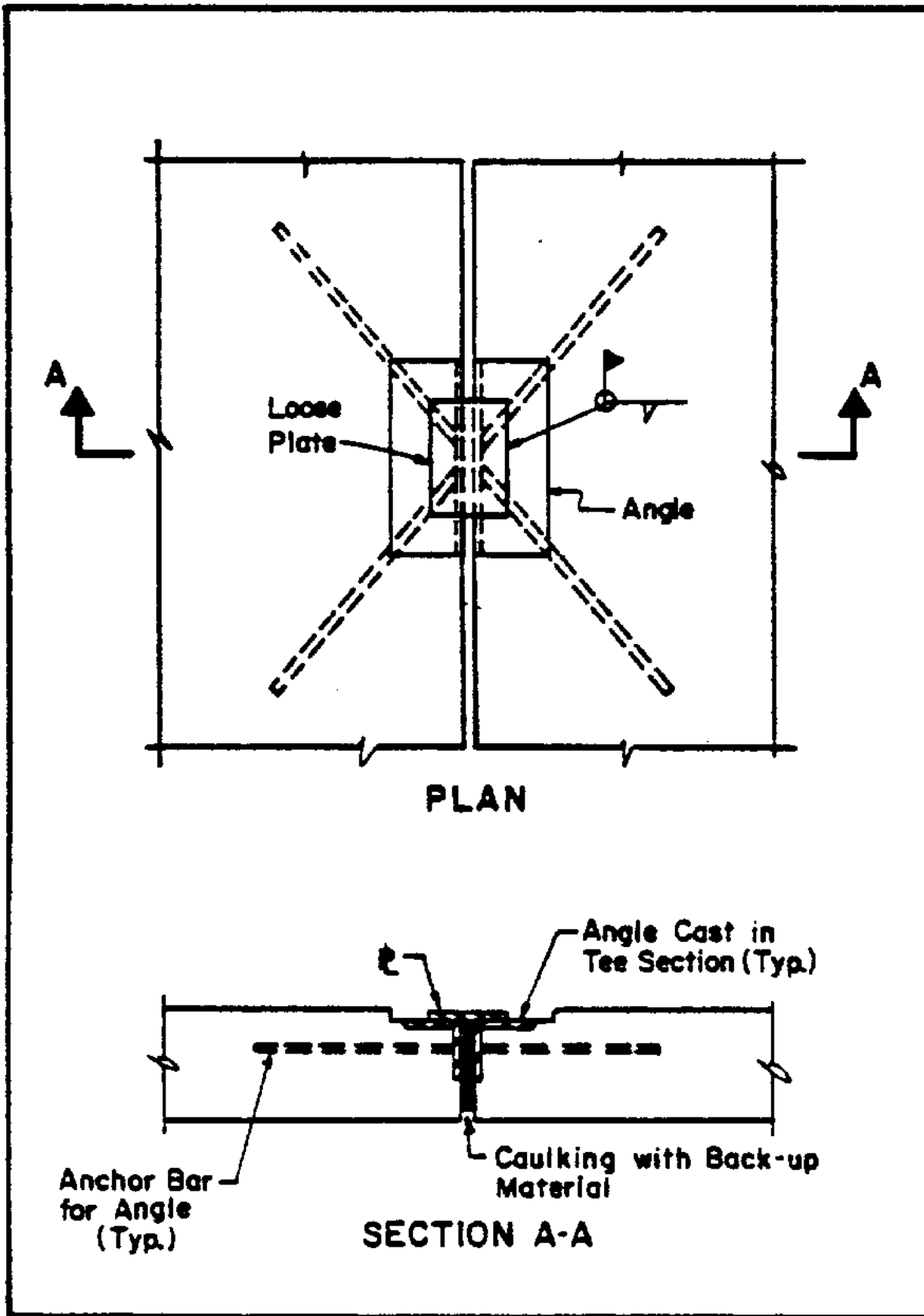

FIGURE 65
Typical Panel Splice

c. Recommended Design Criteria. Several tests have been performed over the years to determine the critical shatter pressures for different types of glass and transparent materials (such as plexiglas), and the results of these tests are published in several reports including those mentioned above as well as Characteristics of Plexiglas Fragments from Windows Broken by Airblast, by Fletcher, et al. For example, Figure 66 shows a plot of critical shatter overpressure vs. pane thickness for different types of plexiglas. The ranges of uncertainty appear as vertical lines. The parallel solid lines (i.e., the lines cutting across the vertical lines) are approximations to the test data. The dashed line was derived from an empirical equation in the report by Taylor and Clark, Shock Tube Tests of Glazing Materials for 22- by 22-inch panes of non-stretched acrylic. Design criteria for maximum blast capacity vs. blast load duration and glass type, and thickness have been developed based upon several tests performed at Dugway Proving Ground in Utah. These design criteria, which are reproduced here, are published in a report by Weissman, et al., Blast Capacity Evaluation of Glass Windows and Aluminum Window Frames. Table 30 presents the peak design blast pressure for various blast load durations vs. glass type and thickness. The peak pressure is either incident or reflected pressure, depending on the orientation of the structural element (glass) with respect to the blast wave. The blast load duration is the duration of an equivalent triangular blast load; procedures for calculating this duration are presented in NAVFAC P-397. The peak pressures in Table 30 are maximum design values for glass panes mounted in rigid window frames, where continuous support for direct load and rebound is provided for the glass. These criteria are applicable to glass areas of 20 square feet or less. The glass capacity tends to be significantly lower with an increase in loaded area (i.e., area of glass exposed to blast loads). It is recommended that glass areas of 20 square feet or less be used in blast design. During the series of tests described in the Weissman report, it was realized that the capacity of the glass panel was directly related to the frame design. For example, in the tests performed with glass mounted in aluminum frames, the capacity of the windows was greatly reduced even where a strengthened frame was used. Therefore, it will be necessary to evaluate the particular frame design selected for use since there are several "off-the-shelf" frame types and details. Depending on the design overpressure level, the frame may require modification or it may be necessary to specify a frame design which will provide sufficient strength and rigidity to develop the capacity of the glass. In view of these probable changes in the design of the frames, a set of specifications has been proposed by Keenan in Review Comments (Partial List) on Design Drawings and Specifications for Unaccompanied Enlisted Quarters, (P-040), Naval Submarine Support Facility, San Diego, CA, for the design of blast resistant windows. The specifications, which are presented below, require acceptance load tests involving application of static pressures to window panes and entire frame assembly. The increased cost of the windows will be negated by the reduction of the risk of injury from glass fragments.

d. Recommended Specifications for Blast Resistant Windows.

(1) Each type of blast resistant window to be used shall be proof tested as a completely assembled unit that includes its glass panes, metal frames, insulated metal panel (where applicable), hardware and anchorages (joining the window frames to the walls). The window used in the proof test shall be life-size and identical in type and construction to those proposed to be furnished.

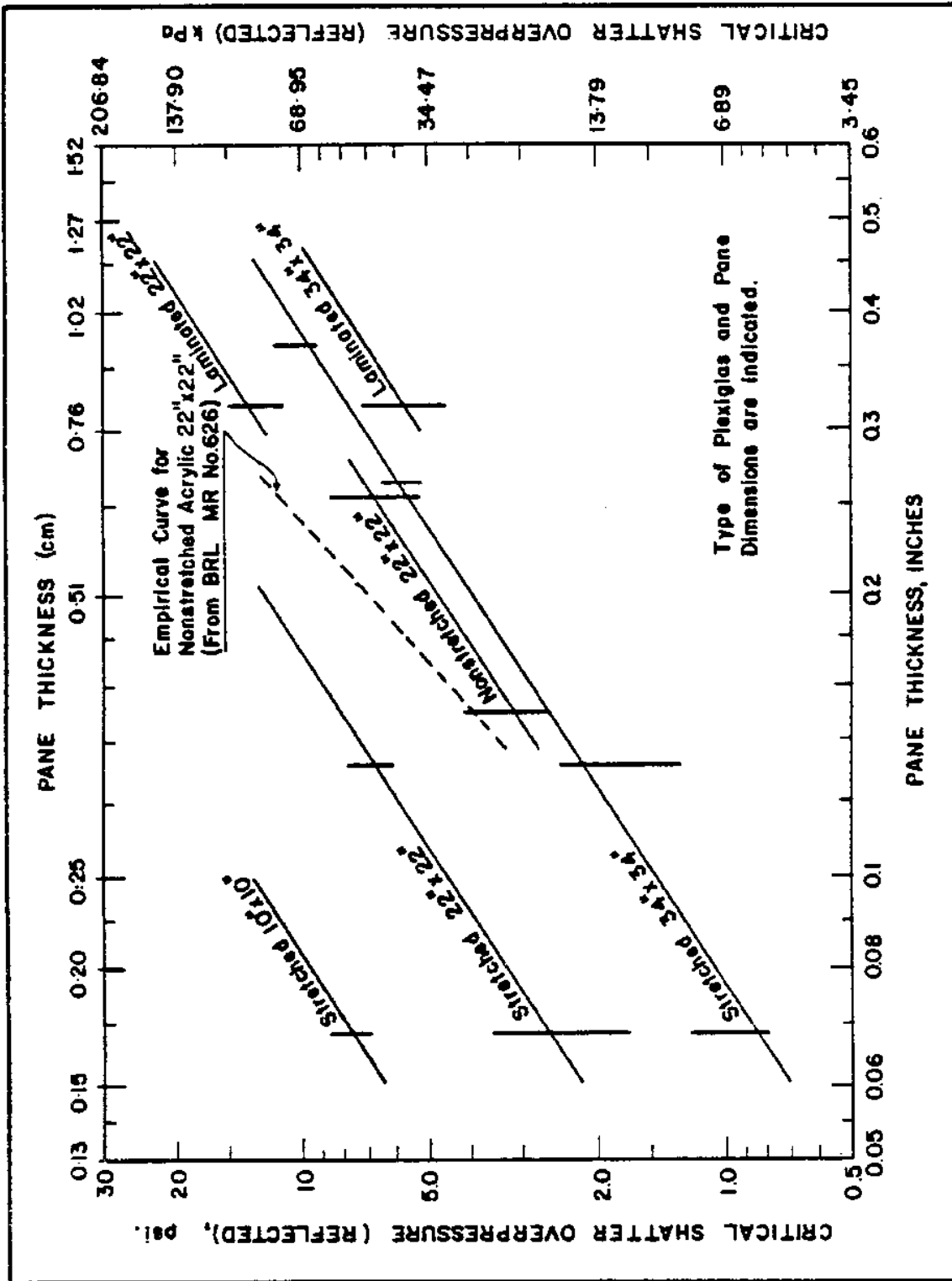

FIGURE 66
Critical Shatter Pressure vs. Pane Thickness for Plexiglas

TABLE 30
 Recommended Design Criteria for Maximum Blast Pressure
 Capacity for Glass Mounted in Rigid Window Frames

(Peak Incident or Reflected Pressure, psi)

Type of Glass	Triangular load duration, msec				
	<10	10-20	21-40	41-100	>100
Tempered 1/8 in	3.0	2.5	2.0	1.5	1.0
Tempered 1/4 in	6.0	4.5	4.0	3.0	2.5
Tempered 3/8 in	8.0	7.0	6.0	5.0	4.0
Regular 1/8 in	0.4	0.3	0.25	0.15	0.1
Regular 1/4 in	0.7	0.6	0.5	0.4	0.3
Regular 3/8 in	0.9	0.8	0.7	0.6	0.5

Notes:

1. Rigid window frame provides continuous support for glass.
2. Blast capacities are applicable to glass area of 20 sq ft or less.
3. Tempered glass shall meet the requirements of ANSI Z97.1.

(2) The proof test shall measure the reliability of the window to develop a minimum capacity or breaking strength for the glass panes. Minimum breaking strength is defined as the mean value of the static test

load capacity, $r_{\Gamma U \gamma}$, for the largest glass pane in the window. The

value, $r_{\Gamma U \gamma}$, shall be based on a minimum of five glass pane tests. In each glass pane test, the load shall be applied uniformly over the face of the glass pane, all edges of the glass pane shall be housed in their adjoining metal frame with rubber gaskets installed, and the metal frame shall be supported continuously along its length on rigid supports that are restrained against deflection and rotation. The window in the test set-up for the proof load test shall be fastened by its anchorages to a rigid surround that simulates the adjoining masonry walls.

(3) The proof load test shall involve subjecting the entire exterior face of the window, including glass panes, metal frames and insulated metal panel (where applicable), to an increasing uniform static load. No pane of glass shall break and the window frame shall not break from its anchorages

under a uniform static pressure load less than $(r_{\Gamma U \gamma} - [\sigma])$, where;

$$\sigma = \left[\frac{\sum (r_u - \bar{r}_u)^2}{n} \right]^{\frac{1}{2}} \quad (\text{one standard deviation})$$

$\bar{r}_u = (\sum r_u)/n$, the mean value of the static test load from glass pane tests

$r_u =$ static test load from the glass pane tests corresponding to failure of an individual glass pane

$n =$ number of glass pane tests ≥ 5

(4) The specific test window that satisfactorily passes the proof load test (no breakage) must also pass a rebound load test before the design is considered acceptable. The rebound test shall consist of a series of preliminary calculations to determine whether the actual test is required. Using either physical properties of the glass or the data obtained from the first part of this test (glass pane test), the fundamental period of vibration of each glass pane is calculated when supported along all edges on non-deflecting supports. Using the period and design blast loading, the maximum rebound stress (or maximum rebound deflection), if any, occurring in each pane of glass during the time interval when the positive pressure phase of the design blast pressure loading acts on the window, is calculated. A four percent viscous damping may be assumed in the calculations. For each glass pane, the equivalent static negative pressure (uniformly distributed over the face of the glass) that would produce the maximum rebound stress, is calculated. The maximum static negative pressure for any pane of glass

is defined as the rebound proof load, $r_{\Gamma U \gamma}$. If analysis shows that no glass pane will rebound (i.e., the rebound proof load ≥ 0), then the rebound load test is not required and the window design that passed the proof test should be considered adequate. However, if the analysis shows that any glass pane will rebound, (i.e., rebound proof load < 0), then the window design must pass the rebound load test.

(5) The rebound load test involves applying an increasing static pressure over the entire face of the specific window that passed the proof load test. The load shall be applied either as a suction pressure over the exterior face of the window or as a positive pressure over the entire interior face of the window. The window design shall be considered acceptable if no glass pane breaks and the window frame does not break free from its anchorage under a static pressure load less than the rebound proof

load, r_{pu} . An official of the contracting agency shall review the test set-up and rebound analysis, and be present to observe the glass pane tests, proof load tests, and rebound tests (if required). Any deviations from this acceptance criteria must be approved by the Contracting Agency. All tests shall be performed by a certified testing laboratory, and all rebound analysis shall be prepared by a Professional Structural Engineer registered in any jurisdiction.

4. SPECIAL PROVISIONS FOR PRE-ENGINEERED BUILDING.

a. General. Standard pre-engineered buildings are usually designed for conventional loads (live, snow, wind and seismic). Blast resistant pre-engineered buildings are also designed in the same manner as standard structures. However, the conventional loadings, which are used for the latter designs, are quite large to compensate for effects of blast loads. Further, as with standard buildings, pre-engineered structures, which are designed for blast, are designed elastically for the conventional loadings with the assumption that the structure will sustain plastic deformations due to the blast. The design approach will require a multi-stage process, including: preparation of general layouts and partial blast designs by the design engineer; preparation of the specifications, by the engineer including certain features as recommended herein; design of the building and preparation of shop drawings by the pre-engineered building manufacturers; and the final blast evaluation of the structure by design engineer utilizing the layouts on the previously mentioned shop drawings. At the completion of the analysis some slight modifications in building design may be necessary. However, if the following procedures are used, then the required modifications will be limited and in some cases eliminated for blast overpressures upward to 2 psi.

b. General Layout. The general layout of pre-engineered buildings is based on both operational and blast resistant requirements. Figure 67 illustrates a typical general layout of the pre-engineered building. The general requirements for development of the layout should include:

(1) Structural Steel.

(a) The maximum spacing between main transverse rigid frames (bay width) shall not exceed 20 feet.

(b) The maximum spacing between column supports for rigid frames shall not exceed 20 feet while the overall height of frames shall be 30 feet or less.

(c) Slope of the roof shall not exceed four horizontal to one vertical. However, the roof slope shall be as shallow as physically possible.

(d) Spacing between girts shall not exceed 4 feet while the space between purlins shall not be greater than 5 feet.

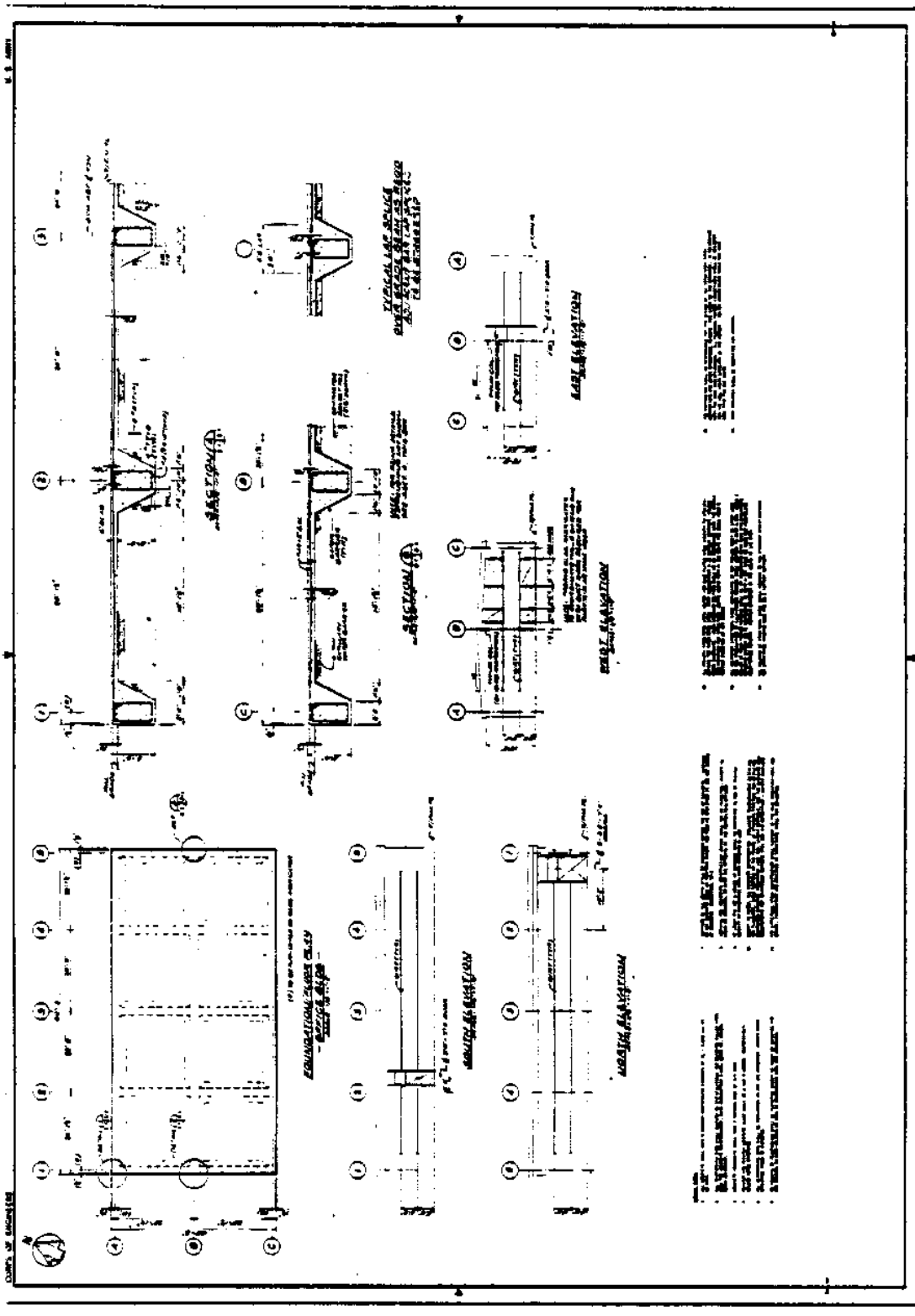

FIGURE 670
Recommended Pre-engineered Building Design Loads

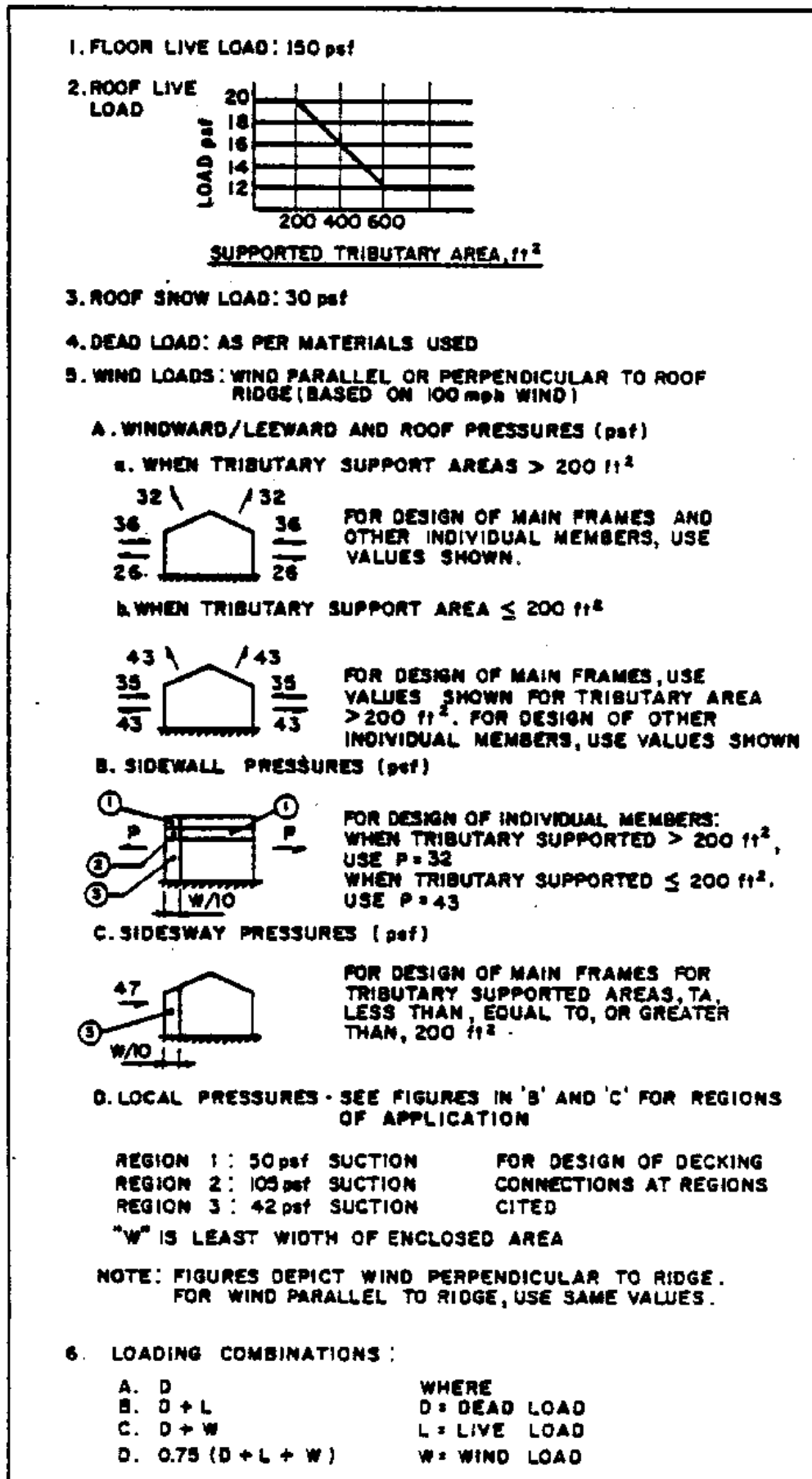

FIGURE 67b

Recommended Pre-engineered Building Design Loads (continued)

(e) Primary members including frames and other main load carrying members shall consist of hot-rolled structural shapes having "I"-shape of constant depth or structural tubing while secondary structural framing such as girts, roof purlins, bridging, eave struts, and other miscellaneous secondary framing shall consist of either hot-rolled or cold-formed structural steel. All primary members and main secondary members (purlins, girts, etc.,) shall be formed from symmetrical "I" sections.

(f) Primary structural framing connections shall be either shop welded or bolted or field bolted assemblies. ASTM A325 bolts with appropriate nuts and washers shall be used for connecting of all primary members; where as secondary members may use bolts conforming to ASTM A307. A minimum of two bolts shall be used for each connection while bolts for primary and secondary members shall not be less than 3/4- and 1/2-inch in diameter, respectively.

(g) Base plates for columns shall be rolled and set on grout bed of 1-inch minimum thickness. ASTM A307 steel bolts shall be used to anchor all columns.

(2) Concrete. Concrete floor and foundation slabs shall be monolithic in construction and shall be designed to transfer all horizontal and vertical loads, as described below, from the pre-engineered superstructure for the foundation soil.

(3) Roof and Wall Coverings.

(a) Roof and wall coverings shall conform to ASTM A 446, G 90, have a corrugation minimum depth of 1-1/2 inches, and have a material thickness of 22 gauge.

(b) Side laps of coverings shall overlap by a minimum of 2-1/2 corrugations. End laps, if required, shall occur at structural steel supports and have a minimum overlap of 12 inches.

(c) Insulation retainers or sub girts shall be designed to transmit all external loads (listed below) which act on the metal cover to the structural steel framing.

(d) Roof and wall liners shall be a minimum of 24 gauge and shall be formed to prevent waviness, distortion or failure as a result of the impact by external loads.

(e) Fasteners for connecting roof and wall coverings to structural steel supports shall be designed to support the external loads (listed below) and shall consist of either self-tapping screws, self-drilling and self-tapping screws, bolts and nuts, self-locking rivets, self-locking bolts, end welded studs, or welds. Fasteners of covering to structural steel shall be located at valleys of the covering and shall have a minimum of one fastener per valley.

(f) Fasteners which do not provide positive locking such as self-tapping screws, etc. shall not be used at side laps and for fastening accessories to panels. At least one fastener for side laps shall be located in each valley and at a maximum spacing along the valley of 8 inches.

(g) Self-tapping screws shall not have a diameter smaller than a no. 14 screw while the minimum diameter of a self-drilling and self-tapping type shall be equal to or greater than a No. 12 screw. Automatic-welded studs shall be shouldered type and have a shank diameter of at least 3/16 inch. Fasteners for use with power actuated tools shall have a shank diameter of not less than 1/2 inch. Blind rivets shall be stainless steel type and have a minimum diameter of 1/8 inch. Rivets shall be threaded stem type if used for other than fastening trim and if of the hollow type shall have closed ends. Bolts shall not be less than 1/4 inch in diameter and will be provided with suitable nuts and washers.

(h) If suction loads dictate, provide oversized washers with a maximum outside diameter of 2 inches or 22-gauge thick metal strip along each valley.

c. Preparation of Partial Blast Analysis. A partial blast analysis of a pre-engineered building shall be performed by the design engineer. This analysis shall include the determination of the minimum size of the roof and wall panels which is included in the design specifications and the design of the building foundation and floor slab. The foundation and floor slab shall be designed monolithically and have a minimum thickness as previously stated. Slab shall be designed for a foundation load equal to either 1.3 times the yield capacity of the building roof equivalent blast load or the static roof and floor loads listed below. Quite often the foundation below the buildings columns must be thickened to distribute the column loads. For the blast analysis of the building foundation and floor slab, the dynamic capacity of the soil below the foundation slab can conservatively be assumed to be equal to twice the static soil capacity. The resistance of the roof of the building can be determined in accordance with the procedures given in the report by Tseng, et al., titled Design Charts for Cold-Formed Steel Panels and Wide-Flange Beams Subjected to Blast Loads. The criteria given in this report have been updated by the results of a series of pre-engineered building tests which have been reported in the report titled Blast Capacity Evaluation of Pre-Engineered Buildings, by Stea, et al. The front panel of the building is designed in the same manner as the roof panel. The blast loads for determining the capacities of the roof and wall panels can be determined from NAVFAC P-397.

d. Pre-Engineered Building Design. Design of the pre-engineered building shall be performed by the pre-engineered building manufacturer using the following static design loads. Conventional stresses as listed in the report titled Specification for the Design, Fabrication and Erection of Structural Steel for Buildings, Manual of Steel Construction shall be used in combination with these loads.

(1) Floor live loads shall be as specified in American National Standard Institute standard A58.1-82, Minimum Design Loads for Buildings and Other Structures (hereafter referred to as ANSI A58.1), but not less than 150 pounds per square foot.

(2) Roof live loads shall be as specified ANSI-58.1.

(3) Dead loads are based on the materials of construction.

(4) Wind pressure shall be as computed in accordance with ANSI A58.1 for exposure "C" and a wind speed of 100 miles per hour.

(5) Seismic loads will be calculated according to the Uniform Building Code for the given area. If this load is greater than the computed wind pressure, then the seismic load will be substituted for wind load in all load combinations.

(6) Auxiliary and collateral loads are all design loads not listed above and include suspended ceilings, insulation, electrical systems, mechanical systems, etc.

(7) Combinations of design loads shall include the following (a) dead loads plus live loads; (b) dead loads plus wind loads, and (c) 75 percent of the sum of dead, live, and wind loads.

e. Blast Evaluation of the Structure. Blast evaluation of the structure utilizing the shop drawings prepared in connection with the above design shall be performed by the design engineer. This evaluation shall be performed in a manner similar to that presented in the report Design of Steel Structures to Resist the Effects of HE Explosions, by Healey, et al. The method of performing a dynamic analysis which describes the magnitude and direction of the elasto-plastic stresses developed in the main frames and secondary members as a result of the blast loads should be similar to that described in the report by Stea, et al., titled Nonlinear Analysis of Frame Structures Subjected to Blast Overpressures. This evaluation should be made at the time of the shop drawing review stage.

f. Recommended Specification for Pre-Engineered Buildings. Specifications for pre-engineered buildings shall be consistent with the recommended design changes set forth in the preceding Section. These example specifications are presented using the Construction Specification Institute (CSI) format and shall contain as a minimum the following:

1. APPLICABLE PUBLICATIONS. The following publications of the issues listed below, but referred to thereafter by basic designation only, form a part of this specification to the extent indicated by the reference thereto:

1.1 American Society of Testing and Materials (ASTM)

A36-81A	Specification for Structural Steel
A307-84	Standard Specification for Carbon Steel Externally Threaded Standard Fasteners
A325-84	Specification for High-Strength Bolts for Structural Steel Joints
A446M-83	Specification for Steel Sheet, Zinc-Coated (Galvanized) by the Hot-Dip Process, Structural (Physical) Quality
A501-84	Specification for Hot-Formed Welded and Seamless Carbon Steel Structural Tubing

A529M-85 Specification for Structural Steel with 42 ksi
(290 PAa) Minimum Yield Point (1/2 in (13 mm)
Maximum Thickness

A570M-85 Specification for Steel, Sheet and Strip, Carbon
Hot-Rolled, Structural Quality

A572M-85 Specification for High-Strength Low-Alloy
Columbium-Vanadium Steels of Structural Quality

1.2 American Iron and Steel Institute (AISI)

SG-672-83 Specification for the Design of Cold-Formed Steel
Structural Members and Commentary

1.3 American National Standards Institute (ANSI)

A58.1-82 Minimum Design Loads for Buildings and Other
Structures

B18.22.1-65 Plain Washers

1.4 American Institute of Steel Construction (AISC)

S326-78 Specification for the Design Fabrication and
Erection of Structural Steel for Buildings with
Commentary

Research Council on Structural Connections

Specification for Structural Joints Using ASTM A325 or A490
Bolts

1.5 American Welding Society (AWS)

D1.1-85 Structural Welding Code

1.6 International Conference of Building Officials (ICBO)

Uniform Building Code

2. GENERAL.

2.1 This section covers the manufacture and erection of pre-engineered metal structures. The structure manufacturer shall be regularly engaged in the fabrication of metal structures and shall be a member of the Metal Building Manufacturer's Association (MBMA).

2.2 The structure shall include the rigid framing, which are spaced at a maximum of 20 feet on center, roof and wall covering, trim, closures, and accessories as indicated on the drawings. Minor alterations in dimensions shown on the drawings will be considered in order to comply with the manufacturer's standards building system, provided that all minimum clearances indicated on the drawings are maintained. Such changes shall be submitted for review and acceptance prior to fabrication.

- 2.3 Drawings shall indicate extent and general assembly details of the metal roofing and sidings. Members and connections not indicated on the drawings shall be designed by the Contractor in accordance with the manufacturer's standard details. The Contractor shall comply with the dimensions, profile limitations, gauges and fabrication details shown on the drawings. Modification of details will be permitted only when approved by the Owner. Should the modifications proposed by the Contractor be accepted by the Owner, the Contractor shall be fully responsible for any re-design and re-detailing of the building construction effected.
3. DEFINITIONS.
 - 3.1 Low Rigid Frame. The building shall be single gable type with the roof slope not to exceed one on six.
 - 3.2 Framing.
 - 3.2.1 Primary Structural Framing. The primary structural framing includes the main transverse frames and other primary load carrying members and their fasteners.
 - 3.2.2 Secondary Structural Framing. The secondary structural framing includes the girts, roof purlins, bridging, eave struts, and other miscellaneous secondary framing members and their fasteners.
 - 3.2.3 Roof and Wall Covering. The roof and wall covering includes the exterior ribbed metal panel having a minimum depth of one and one-half inches, neoprene closure, fasteners and sealant.
 - 3.3 Building Geometry.
 - 3.3.1 Roof Slope. The roof of the building shall have a maximum slope not to exceed one on six.
 - 3.3.2 Bay Spacing. The bay spacing shall not exceed 20 feet.
 - 3.4 Column Shape. Main frame and endwall columns shall be constant depth; tapered columns will not be permitted.
 - 3.5 Calculations. The Contractor shall submit for review complete design calculations for all work, sealed by a registered professional engineer.
4. STRUCTURAL DESIGN.
 - 4.1 Structural Analysis. The structural analysis of the primary and secondary framing and covering shall be based on linear elastic behavior and shall accurately reflect the final configuration of the structure and all tributary design loadings.
 - 4.2 Basic Design Loads.

- 4.2.1 Roof Live Load. Shall be applied to the horizontal roof protection. Roof live loads shall be:
- 0 to 200 square feet tributary area - 20 psf
- 200 to 600 square feet tributary area - linear variation 20 psf to 12 psf
- over 600 square feet tributary area - 12 psf
- 4.2.2 Wind Pressure. Wind design loads shall be computed in accordance with ANSI A58.1 for exposure "C" and a basic wind speed of 100 miles per hour.
- 4.2.2.1 Typical Wind Loading. As shown on drawings (Figure 67b).
- 4.2.2.2 Wind Loading at Building Corners. As shown on the drawings (Figure 67b).
- 4.2.2.3 Wind Loading on Girts. As shown on drawings (Figure 67b).
- 4.2.2.4 Wind Loading on Purlins and Roof Tributary Areas. As shown on drawings (Figure 67b).
- 4.2.2.5 Wind Loading for Design of Overall Structure. As shown on drawings (Figure 67b).
- 4.2.3 Auxiliary and Collateral Design Loads. Auxiliary and collateral design loads are those loads other than the basic design live, dead, and wind loads; which the building shall safely withstand, such as ceilings, insulation, electrical, mechanical, and plumbing systems, and building equipment and supports.
- 4.3 Application of Design Loads.
- 4.3.1 Roof Live Load and Dead Load. The roof live load (L), and dead load (D), shall be considered as a uniformly distributed loading acting vertically on the horizontal projection of the roof.
- 4.3.2 Snow Loads. Application of 30 psf due to snow loads.
- 4.3.3 Wind Loads (W). Application of forces due to wind shall conform to ANSI A58.1.
- 4.3.4 Combination of Loads. The following combinations of loads shall be considered in the design of all members of the structure:
- D + L
D + W
.75 (D + L + W)
- 4.4 Deflection Limitations.
- 4.4.1 Structural Framing. The primary and secondary framing members shall be so proportioned that their maximum calculated roof live load deflection does not exceed 1/120 of the span.

5. STRUCTURAL FRAMING.
- 5.1 General
- 5.1.1 All hot rolled structural shapes and structural tubing shall have a minimum yield point of 36,000 psi in conformance with ASTM A36 or A501. All hot-rolled steel plate, strip, and sheet used in the fabrication of welded assemblies shall conform to the requirements of ASTM A529, A572, Grade 42 or A570 Grade "E" as applicable. All hot-rolled sheet and strip used in the fabrication of cold-formed members shall conform to the requirements of ASTM A570, Grade "E" having a minimum yield strength of 50,000 psi. Design of cold-formed members shall be in accordance with the AISI specifications.
- 5.1.2 The minimum thickness of framing members shall be:
- | | |
|---------------------------------------|------------|
| Cold-formed secondary framing members | - 18 gauge |
| Pipe or tube columns | - 12 gauge |
| Webs of welded built-up members | - 1/8 inch |
| Flanges of welded built-up members | - 1/4 inch |
| Bracing rods | - 1/4 inch |
- 5.1.3 All framing members shall be fabricated for bolted field assembly. Bolt holes shall be punched or drilled only. No burning-in of holes will be allowed. The faying surfaces of all bolted connections shall be smooth and free from burrs or distortions. Provide washers under head and nut of all bolts. Provide beveled washers to match sloping surfaces as required. Bolts shall be of type specified below. Members shall be straight and dimensionally accurate.
- 5.1.4 All welded connections shall be in conformance with the Structural Welding Code D1.1 of the American Welding Society. The flange-to-web welds shall be one side continuous submerged or fillet welds. Other welds shall be by the shielded arc process.
- 5.2 Primary Structural Framing.
- 5.2.1 The main frames shall be welded "I" shape of constant depth fabricated from hot-rolled steel sheet, strip and plates, or rolled structural shapes.
- 5.2.2 Compression flanges shall be laterally braced to withstand any combination of loading.
- 5.2.3 Bracing system shall be provided to adequately transmit all lateral forces on the building to the foundation.
- 5.2.4 All bolt connections of primary structural framing shall be made using high-strength zinc-plated (0.0003 bronze zinc plated) bolts, nuts, and washers conforming to ASTM A325. Bolted connections shall have not less than two bolts. Bolts shall not be less than 3/4 inch diameter. Shop welds and field bolting are preferred. All field welds will require prior approval of the Owner. Installation of fasteners shall be by the turn-of-nut or load-indicating washer method in accordance with the specifications for structural joints of the Research Council on Riveted and Bolted Structural Joints.

- 5.3 Secondary Structural Framing. Secondary members may be constructed of either hot-rolled or cold-formed steel. Purlins and girts shall be doubly symmetrical sections of constant depth and they may be built-up, cold-formed, or hot-rolled structural shapes
- 5.3.1 Maximum spacing of roof purlins and wall girts shall not exceed 4 feet.
- 5.3.2 Compression flanges of purlins and girts shall be laterally braced to withstand any combination of loading.
- 5.3.3 Supporting lugs shall be used to connect the purlins and girts to the primary framing. The lugs shall be designed to restrain the light gauge sections from tripping or warping at their supports. Each member shall be connected to each lug by a minimum of two fasteners.
- 5.3.4 End wall columns shall be hot rolled and shall consist of welded built-up "I" section or structural steel "C" or "I" shapes.
- 5.3.5 Fasteners for all secondary framing shall be 1/2 inch diameter (0.003 zinc plated) bolts conforming to ASTM A307. The fasteners shall be tightened to "snug tight" condition. Plain washers shall conform to ANSI standard B18.22.1.

6. ANCHORAGE.

- 6.1 Anchorage. The building anchor bolts for both primary and secondary columns shall conform to ASTM A307 steel and shall be designed to resist the column reactions produced by the specified design loading. The quantity, size and location of anchor bolts shall be specified and furnished by the building manufacturer. A minimum of two anchor bolts shall be used with each column.
- 6.2 Column Base Plates. Base plates for columns shall conform to ASTM A36 and shall be set on a grout bed of 1 inch minimum thickness.

7. ROOF AND WALL COVERING.

- 7.1 Roof and wall panels shall conform to zinc-coated steel, ASTM A446, G90 coating designation. Minimum depth of each panel corrugation shall be 1-1/2 inches and shall have a material thickness of 22 gauge. The minimum yield strength of panel material shall be 33,000 psi. Wall panels shall be applied with the longitudinal configurations in the vertical position. Roof panels shall be applied with the longitudinal configuration in direction of the roof slope.
- 7.1.1 Structural properties of roof and wall panels shall be equal to or greater than the following:

Section Modulus (in³/ft)

Surface	Roof	Wall
Outer Face in Compression		
Outer Face in Tension		

- 7.1.2 Side and End Laps. Side laps of roof and wall panels shall overlap by minimum of 2-1/2 corrugations (2 valleys). End laps, if required shall occur at structural steel supports and have a minimum length of 12 inches.
- 7.2 Insulation.
 - 7.2.1 Semi-rigid insulation for the preformed roofing and siding shall be supplied and installed by the preformed roofing and siding manufacturer.
 - 7.2.2 Insulation Retainers. Insulation retainers or sub-girts shall be designed to transmit all external loads (wind, snow and live loads) acting on the metal panels to the structural steel framing. The retainers shall be capable of transmitting both the direct and suction loads.
- 7.3 Wall and Roof Liners. Wall and roof liners shall be a minimum of 24 gauge. All liners shall be formed or patterned to prevent waviness, distortion, or failure as a result of the impact by external loads.
- 7.4 Fasteners. Fasteners for roof and wall panels shall be zinc-coated steel or corrosion-resisting steel. Exposed fasteners shall be gasketed or have gasketed washers of a material compatible with the covering to waterproof the fastener penetration. Gasketed portion of fasteners or washers shall be neoprene or other elastomeric material approximately 1/8 inch thick.
 - 7.4.1 Type of Fasteners. Fasteners for connection roof or wall panels to structural steel supports shall consist of self-tapping screws, self-drilling and self-tapping screws, bolts, end welded studs, and welds. Fasteners for panels which connect to structural supports shall be located in each valley of the panel and with a minimum of one fastener per valley while at end laps and plain ends, a minimum of two fasteners shall be used per valley. Fasteners shall not be located at panel crowns.
 - 7.4.2 Fasteners which do not provide positive locking such as self-tapping screws or self-drilling and self-tapping screws shall not be used at side laps of panels and for fastening accessories to panels. Fasteners for side laps shall be located in each valley of the overlap and positions a maximum of 8 inches on center.
 - 7.4.3 Screws shall be not less than no. 14 diameter if self-tapping type and not less than No. 12 diameter if self-drilling and self-tapping type.
 - 7.4.4 Automatic end-welded studs shall be shouldered type with a shank diameter of not less than 3/16 inch with cap and nut for holding the covering against the shoulder.
 - 7.4.5 Fasteners for use with power actuated tools shall have a shank diameter of not less than 1/2 inch. Fasteners for securing wall panels shall have threaded studs for attaching approved nuts or caps.

- 7.4.6 Blind rivets shall be stainless steel with 1/8 inch nominal diameter shank. Rivets shall be threaded stem type if used for other than fastening of trim. Rivets with hollow stems shall have closed ends.
- 7.4.7 Bolts shall not be less than 1/4 inch diameter, shoulders or plain shank as required with proper nuts.
- 7.4.8 Provide overside washers with an outside diameter of 1 inch at each fastener or a 22-gauge thick metal strip along each valley of the panel to negate pull-out of the panel around the fasteners.

5. EXAMPLE PROBLEMS.

a. Masonry Wall Design.

Problem:

Design midspan of a joint reinforced masonry wall supported by steel columns for an exterior blast load. Use hollow concrete masonry units.

Given:

- (1) Clear span.
- (2) Pressure-time loading.
- (3) Deflection criteria.

Solution:

- (1) Select masonry unit size and reinforcing steel.
- (2) Calculate dynamic properties of materials.
- (3) Calculate ultimate moment capacity of the section.
- (4) Find ultimate resistance of the wall according to Section 5-10 of NAVFAC P-397.
- (5) Determine E_m and I_m of the section using Table 29 and Equations (125), (130), and (131)
- (6) Find equivalent stiffness from Table 7.
- (7) Calculate equivalent elastic deflection.
- (8) Determine load-mass factor from Section 6-6 of NAVFAC P-397.
- (9) Calculate effective mass of the wall section using Table 27.
- (10) Using Equation (1), find natural period of wall.

- (11) Determine maximum deflection from Figure 6-7 of NAVFAC P-397; check criteria.
- (12) Calculate ultimate shear stress from Equation (127)
- (13) Determine required area of shear reinforcing using Equation (128)
- (14) Find rebound shear at support and required area of anchor reinforcing. Use Figure 6-8 of NAVFAC P-397.

Calculation:

Given:

- (1) Clear span between columns, 150 inches
- (2) Pressure-Time loading as shown in Figure 68a.
- (3) Maximum support rotation, 0.5 degree

Solution:

- (1) Use 12-inch wide hollow concrete masonry units and ladder type reinforcing with No. 8 gauge side rods and No. 9 gauge cross rods 16 inches on center. Assume $d_{rb} = 10$ inches for this type of reinforcing.
- (2) Reinforcing steel in tension or compression:

$$\begin{aligned}
 f_{rdy} &= f_{ry} \times DIF \\
 &= 70000 \times 1.10 \\
 &= 77,000 \text{ psi}
 \end{aligned}$$

Concrete in shear

$$\begin{aligned}
 f_{LJ}^{\prime} f_{dm} &= f_{LJ}^{\prime} f_{m} \times DIF \\
 &= 1350 \times 1.00 \\
 &= 1,350 \text{ psi}
 \end{aligned}$$

- (3) Use one layer of reinforcing between every masonry unit joint, therefore 8 inches on center.

$$\begin{aligned}
 A_{rs} &= .0206/8 \\
 &= .0026 \text{ in}^2/\text{in}
 \end{aligned}$$

$$\begin{aligned}
 M_u &= A_{rs} f_{rdy} d_{rs} \\
 &= .0026 \times 77,000 \times 10 \\
 &= 2002 \text{ in-lb/in}
 \end{aligned}$$

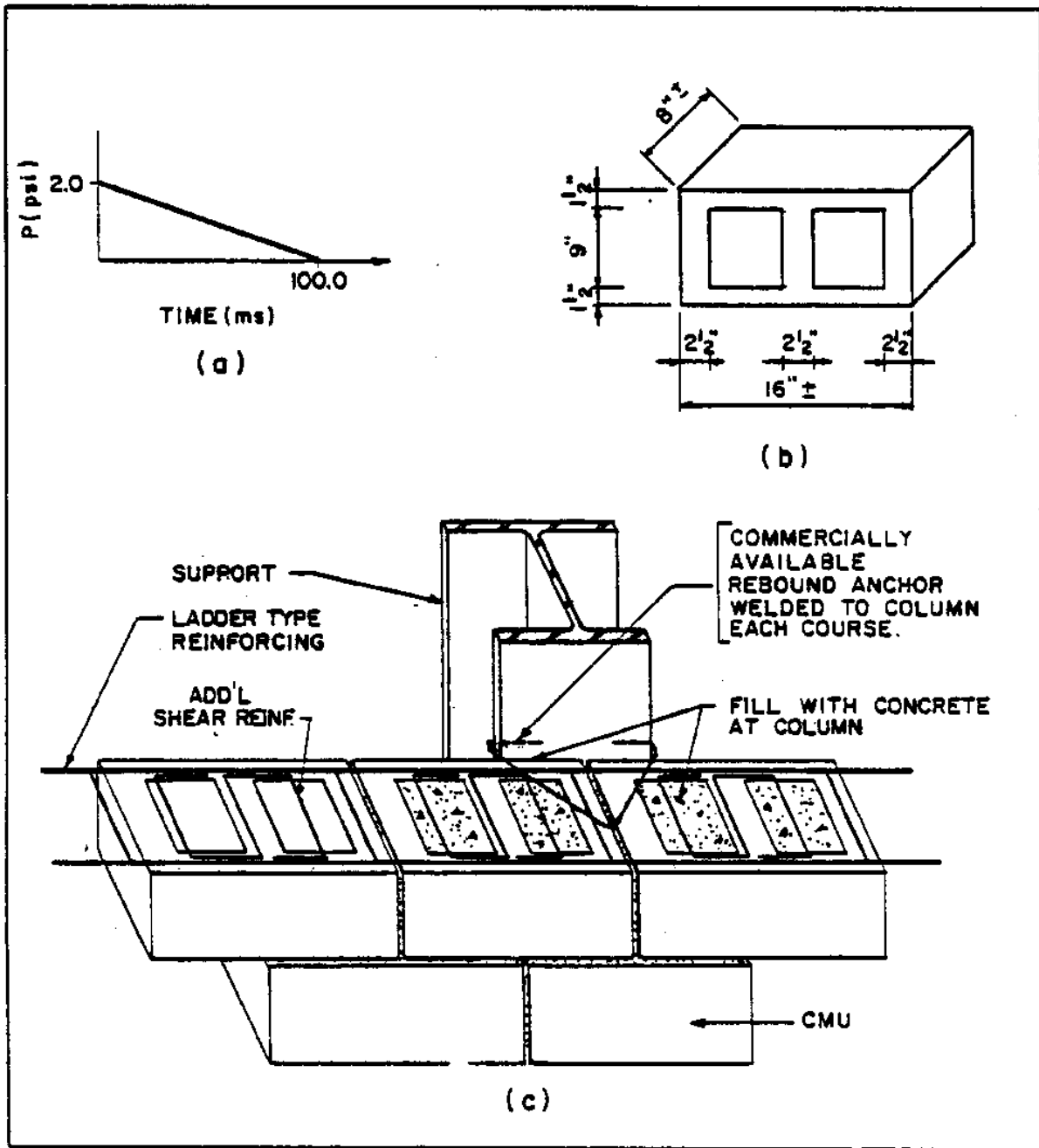

FIGURE 68
Example Problem for Design of Masonry Wall

(4) From Section 5-10 of NAVFAC P-397,

$$\begin{aligned} r_{\Gamma u} &= \frac{8(M_{\Gamma N} + M_{\Gamma P})}{L^2} \\ &= \frac{8(2002 + 2002)}{150^2} \\ &= 1.42 \text{ psi} \end{aligned}$$

(5) From Table 29 for a 12-inch unit,

$$I_{\Gamma n} = 83.3 \text{ in}^4/\text{in}$$

Using Equations (130) and (131) for $b = 1$ inch:

$$\begin{aligned} I_{\Gamma c} &= .005 \times d^3 \Gamma b \\ &= .005 \times 10^3 \\ &= 5.0 \text{ in}^4/\text{in} \end{aligned}$$

$$\begin{aligned} I_{\Gamma a} &= \frac{I_{\Gamma n} + I_{\Gamma c}}{2} \\ &= \frac{83.3 + 5.0}{2} \\ &= 44.2 \text{ in}^4/\text{in} \end{aligned}$$

From Equation (125), modulus of elasticity is

$$\begin{aligned} E_{\Gamma m} &= 1000 f'_{\Gamma m} \\ &= 1,000 \times 1,350 \\ &= 1.35 \times 10^6 \text{ psi} \end{aligned}$$

(6) Equivalent stiffness from Table 7,

$$\begin{aligned} K_{\Gamma E} &= 307 E_{\Gamma m} I_{\Gamma a} / L^3 \\ &= 307 \times 1.35 \times 10^6 \times 44.2 / 150^3 \\ &= 36.19 \text{ psi/in} \end{aligned}$$

(7) Equivalent elastic deflection,

$$\begin{aligned} X_{\Gamma E} &= r_{\Gamma u} / K_{\Gamma E} \\ &= \frac{1.42}{36.19} \\ &= 0.039 \text{ in} \end{aligned}$$

(8) From Section 6-6 of NAVFAC P-397

$$\begin{aligned} K_{\Gamma LM} \text{ Elastic} &= .77 \\ K_{\Gamma LM} \text{ Elasto-plastic} &= .79 \\ K_{\Gamma LM} \text{ Plastic} &= .66 \end{aligned}$$

Load-mass factor for plastic range is,

$$\begin{aligned} K_{\Gamma LM} &= [(.77 + .79)/2 + (.66)]/2 \\ &= .72 \end{aligned}$$

- (9) Calculate weight of a single concrete unit using Table 27 (see Figure 68b).

$$W = [(16 \times 12 - 2(4.25 \times 9))] \times 8 \times 150/12 \text{ L}^3 \\ = 80.0 \text{ lb}$$

Effective unit mass of the wall is,

$$m_{re} = K_{rLM} \times \frac{W}{\text{Area} \times g} \\ = .72 \times \frac{80}{(16 \times 8) \times 386.4} \\ = 1164.6 \text{ lb-ms}^2/\text{in}^2$$

- (10) From Equation (1),

$$T_{rN} = 2[\pi] (m_{re}/K_{rE}) \text{ L}^{1/2} \\ = 2[\pi] (1164.6/36.19) \text{ L}^{1/2} \\ = 35.6 \text{ ms}$$

- (11) Find support rotation using Figure 6-7 of NAVFAC P-397 and Figure 68a.

$$B/r_{ru} = 2.0/1.42 \\ = 1.4$$

$$T/T_{rN} = 100.0/35.6 \\ = 2.8$$

[therefore] $X_{rm}/X_{rE} = 16.5$

$$X_{rm} = 16.5 \times .039 \\ = .644 \text{ in}$$

$$[\theta] = \tan^{-1} (2X_{rm}/L) \\ [\theta] = \tan^{-1} (2 \times .644/150) \\ = 49[\text{deg}] < .50[\text{deg}] \text{ O.K.}$$

- (12) Ultimate shear at $d_{rb}/2$ from support,

$$V_{ru} = r_{ru} (L - d_{rb})/2 \\ = 1.42 (150 - 10)/2 \\ = 99.4 \text{ lb/in}$$

Net area of the section from Table 27

$$A_{rn} = 2 \times b \times \text{Face thickness}/b \\ = 2 \times 8 \times 1.5/8 \\ = 3.0 \text{ in}^2/\text{in}$$

From Equation (127), ultimate shear stress is

$$\begin{aligned} v_{\tau u} &= \frac{V_{\tau u}}{A_{\tau n}} \\ &= 99.4/3.0 \\ &= 33.1 \text{ psi} \end{aligned}$$

- (13) Required area of shear reinforcing from Equation (128) assuming $s = 4$ inches

$$\begin{aligned} A_{\tau v} &= \frac{v_{\tau u} b s}{[\phi] \tau_y f} \\ &= \frac{33.1 \times 8 \times 4}{.85 \times 70000} \\ &= .0178 \text{ in}^2 \text{ No. 9 gauge} \end{aligned}$$

Use 3 legs of No. 9 gauge wire at 4 inches on center.

- (14) Using $T/T_{N\tau}$ of 2.8 and $X_{\tau m\tau}/X_{\tau E\tau}$ of 16.5, rebound from Figure 6-8 of NAVFAC P-397 is

$$\begin{aligned} r^L_{\tau} &= .58 \\ r^L_{\tau} &= .58 \times 1.42 \\ &= .82 \text{ psi} \end{aligned}$$

Rebound shear at support,

$$\begin{aligned} V_{\tau r} &= \frac{r^L_{\tau} \times L}{2} \\ &= \frac{.82 \times 150}{2} \\ &= 61.5 \text{ lb/in} \end{aligned}$$

Required area of anchor reinforcing.

Use 3/16-inch diameter triangular ties.

b. Design of Precast Prestressed Roof.

Problem: Design a precast prestressed roof (double tee section) for the blast loads shown.

Given:

- (1) Pressure-time loading.
- (2) Material strength.
- (3) Dynamic increase factors.

- (4) Span length.
- (5) Live load.

Solution:

- (1) Select a standard double tee section.
- (2) Select a strand pattern.
- (3) Calculate dynamic strength of materials.
- (4) Design flange for given blast load using procedures given in NAVFAC P-397, considering flange a one way slab.
- (5) Design flange for rebound load.
- (6) Calculate section properties of double tee section.
- (7) Calculate the average stress in prestressing strand from Equations (145) thru (148).
- (8) Determine flexural capacity of section.
- (9) Using Table 5, find the ultimate resistance of section.
- (10) Find equivalent elastic stiffness using equations of Table 7.
- (11) Using the load-mass factor found in Table 10, calculate the effective mass.
- (12) Calculate natural period of vibration.
- (13) Using Figure 6-7 of NAVFAC P-397, determine response of section. Section must remain elastic ($X_{\text{max}}/X_{\text{E}} < / = 1.0$). If it does not, steps 1 through 13 must be repeated.
- (14) Check that steel ratios are less than that permitted by Equation (149) or (150).
- (15) Design section for rebound.
- (16) Design shear reinforcement in accordance with provisions of Section 3.
- (17) Check if section is adequate for service loads using PCI design handbook and ACI code. (Not shown in this example)

Calculation:

Given:

- (1) Equivalent pressure-time curve is shown in Figure 69a.

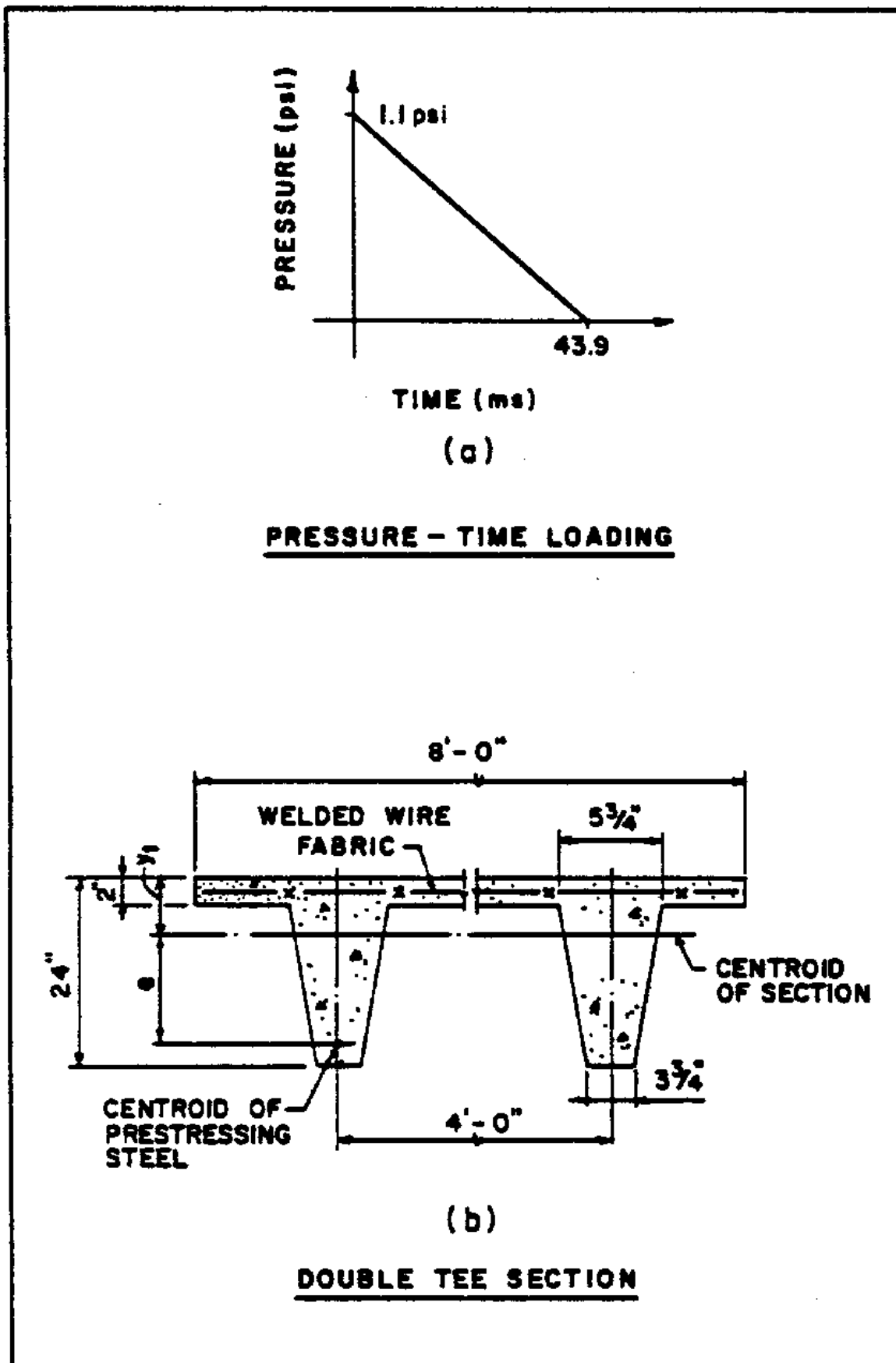

FIGURE 69

Design of Prestressed Precast Roof

(2) Material strengths

Concrete:	$f'_c = 5000$ psi
Prestressing Steel:	$f_{pu} = 270,000$ psi
	$f_{py}/f_{pu} = 0.85$
Welded Wire Fabric:	$f_y = 65,000$ psi
Reinforcing Bars:	$f_y = 60,000$ psi

(3) Dynamic increase factors:

Concrete	
flexure:	1.25
diagonal tension:	1.00
direct shear:	1.10
Prestressing Steel:	1.0
Welding Wire Fabric:	1.10
Reinforcing Steel	
flexure:	1.10
shear:	1.0

(4) Span length: 40 ft.

(5) Live load: 15 psf

Solution:

(1) Select a double tee section.

Try 8DT 24 shown in Figure 69b with section properties:

$$\begin{aligned}
 A &= 401 \text{ in}^2 && \text{WWF 12 X 6, W1.4 X W2.5 in flange} \\
 I_s &= 20,985 \text{ in}^4 \\
 y_t &= 6.85 \text{ in} \\
 W &= 418 \text{ lb/ft}
 \end{aligned}$$

(2) Select Strand Pattern.

Try strand pattern 48-S, two 1/2-inch diameter strands in each tee.

$$\begin{aligned}
 \text{Area of each strand} &= 0.153 \text{ in}^2 \\
 e &= 14.15 \text{ in}
 \end{aligned}$$

(3) Calculate dynamic strength of materials.

Concrete

$$- \text{ flexure: } f'_{dc} = 1.25 \times 5,000 = 6250 \text{ psi}$$

$$- \text{ diagonal tension: } f'_{dc} = 1.0 \times 5,000 = 5000 \text{ psi}$$

$$- \text{ direct shear: } f'_{dc} = 1.1 \times 5,000 = 5500 \text{ psi}$$

$$\text{Prestressing Steel: } f_{py} = 1.0 \times 270,000 = 270,000 \text{ psi}$$

$$\text{Welded Wire Fabric: } f_{dy} = 1.10 \times 65,000 = 71,500 \text{ psi}$$

Reinforcing Bars

$$- \text{ flexure: } f_{dy} = 1.10 \times 60,000 = 66,000 \text{ psi}$$

$$- \text{ shear: } f_{dy} = 1.0 \times 60,000 = 60,000 \text{ psi}$$

(4) Design of flange section.

Critical section of flange is the cantilever portion

$$\begin{aligned} L &= 24 - 5.75/2 \\ &= 21.125 \text{ in} \end{aligned}$$

$$d = 1.0 \text{ in (welded wire fabric is located in the middle of the flange) per one foot section}$$

$$\begin{aligned} a &= (A_s f_y d) / (.85 f'_{cb}) \\ &= .05(71500) / (.85 \times 6250 \times 12) \\ &= 0.056 \text{ in} \end{aligned}$$

$$\begin{aligned} M_u &= A_s f_y d (d-a/2) / b \\ &= 0.05 \times 71500 (1 - 0.056/2) / 12 \\ &= 290 \text{ in-lb/in} \end{aligned}$$

Elastic resistance, r_u , is:

$$\begin{aligned} r_u &= 2M_u / L^2 \\ &= 2 \times 290 / (21.125)^2 \\ &= 1.30 \text{ psi} \end{aligned}$$

Resistance available to resist blast load, r , is:

$$\begin{aligned} r_{avail} &= r_u - DL - LL \\ &= 1.30 - (2 \times 150/12) - 15/12 \\ &= 1.30 - .17 - .10 \\ &= 1.03 \text{ psi} \end{aligned}$$

The elastic range stiffness of section, K_E

$$K_E = 8E_c I_a / L^3$$

where,

$$\begin{aligned} E_c &= 33(150)^{1.5} (5,000)^{1/2} \\ &= 4,286,825.8 \text{ psi} \end{aligned}$$

$$\begin{aligned} I_a &= 0.6 I_g \\ &= 0.6(2)^3 / 12 \\ &= 0.4 \text{ in}^4 / \text{in} \end{aligned}$$

$$\begin{aligned} K_E &= 8(4,286,825.8)(0.4) / (21.125)^3 \\ &= 68.88 \text{ psi/in} \end{aligned}$$

The mass, m , of element,

$$\begin{aligned} m &= (150/12 \times 2) / (32.2 \times 12 \times 10^{-6}) \\ &= 449.30 \text{ lb-ms}^2 / \text{in}^2 \end{aligned}$$

Load mass factor (from Table 6-1, NAVFAC P-397) in the elastic range, $K_{LM} = 0.65$

Thus the effective mass of the element is:

$$\begin{aligned} m_{re} &= m_{KL} \\ &= 449.30 \times 0.65 \\ &= 292.04 \text{ lb-ms}^2/\text{in}^2 \end{aligned}$$

and the natural period of vibration is equal to:

$$\begin{aligned} T_N &= 2[\pi] (m_{re}/K_E)^{1/2} \\ &= 2[\pi] (292.04/68.88)^{1/2} \\ &= 12.9 \text{ ms} \end{aligned}$$

$$\begin{aligned} T/T_N &= 43.9/12.9 & B/r &= 1.1/1.03 \\ &= 3.40 & &= 1.07 \end{aligned}$$

Entering Figure 6-7 of NAVFAC P-397 with these ratios;

$$X_m/X_E = 5.5 \text{ No Good; section must remain elastic.}$$

Increase flange thickness to 3 inches and use two layers of welded wire fabric, 6 X 6 - W1.4 X W2.0 in top layer

$$\begin{aligned} d &= 3 - .625 - (0.159/2) \\ &= 2.25 \text{ in} \end{aligned}$$

$$\begin{aligned} a &= 0.04 \times 71,500 / (.85 \times 6250 \times 12) \\ &= 0.045 \text{ in} \end{aligned}$$

$$\begin{aligned} M_u &= 0.04 \times 71,500 (2.25 - 0.045/2) / 12 \\ &= 531 \text{ in-lb/in} \end{aligned}$$

$$\begin{aligned} r_u &= 2 \times 531 / (21.125)^2 \\ &= 2.38 \text{ psi} \end{aligned}$$

Available resistance

$$\begin{aligned} r_{avail} &= 2.38 - 0.26 - 0.10 \\ &= 2.02 \text{ psi} \end{aligned}$$

$$\begin{aligned} I_a &= 0.6 \times 3^3 / 12 \\ &= 1.35 \text{ in}^4/\text{in} \end{aligned}$$

$$\begin{aligned} K_E &= 8(4,286,825.8) (1.35) / (21.125)^4 \\ &= 232.47 \text{ psi/in} \end{aligned}$$

$$\begin{aligned} m &= (150/12^3 \times 3) / (32.2 \times 12 \times 10^{-6}) \\ &= 673.96 \text{ lb-ms}^2/\text{in}^2 \end{aligned}$$

$$\begin{aligned} m_{re} &= 0.65 \times 673.96 \\ &= 438.07 \text{ lb-ms}^2/\text{in}^2 \end{aligned}$$

$$\begin{aligned} T_N &= 2[\pi] (438.07/232.47)^{1/2} \\ &= 8.6 \text{ ms} \end{aligned}$$

$$\begin{aligned} T/T_N &= 43.9/8.6 & B/r &= 1.1/2.02 \\ &= 5.10 & &= 0.54 \end{aligned}$$

Extrapolating from Figure 6-7 of NAVFAC P-397

$$X_{r_m} / X_{r_E} = 1.0$$

Thus $r_{r_{attained}} = r_{r_{available}}$ O.K.

(5) Design flange for rebound.

Using NAVFAC P-397, Figure 6-8,

$$r^L_{-J} r_{r_u} = -0.6$$

$$\begin{aligned} r^L_{-J} &= -0.6(2.02) \\ &= 1.21 \text{ psi} \end{aligned}$$

$$\begin{aligned} r_{r_{required}} &= r^L_{-J} - DL \\ &= 1.21 - (3 \times 150/12 \text{ } ^L_3) \\ &= 0.95 \text{ psi} \end{aligned}$$

$$\begin{aligned} M^L_{-J} r_{r_u} &= r^L_{-J} (L) \text{ } ^L_2 / 2 \\ &= 0.95(21.125) \text{ } ^L_2 / 2 \\ &= 211.98 \text{ in-lb/in} \end{aligned}$$

Assume $a = 0.04$ inch

$$\begin{aligned} A_{r_s} &= M^L_{-J} r_{r_u} / [f_{r_{dy}} (d - a/2)] \\ &= 211.98 / [71,500(2.25 - 0.02)] \\ &= 0.0013 \text{ in } ^L_2 / \text{in} \end{aligned}$$

$$\begin{aligned} a &= A_{r_s} f_{r_{dy}} / (.85 f_{r_{dc}} 'b) \\ &= 0.0013(71500) / (.85 \times 6250 \times 1) \\ &= 0.017 \text{ in} \quad \text{No Good} \end{aligned}$$

Assume $a = 0.018$ inch

$$\begin{aligned} A_{r_s} &= 211.98 / [71,500(2.25 - 0.009)] \\ &= .0013 \text{ in } ^L_2 / \text{in} \end{aligned}$$

$$\begin{aligned} a &= 0.0013(71500) / (.85 \times 6250 \times 1) \\ &= 0.017 \text{ in} = 0.018 \text{ in} \quad \text{O.K.} \end{aligned}$$

Bottom layer of WWF 6 X 6 W1.4 X W1.4

Check that section of flange spanning between tee section is not critical.

$$r_{r_u} = 8(M_{r_N} + M_{r_P}) / L \text{ } ^L_2$$

$$\begin{aligned} M_{r_N} &= 531 \text{ in-lb/in} \\ M_{r_P} &= 373 \text{ in-lb/in} \\ L &= 48 - 5.75 = 42.25 \end{aligned}$$

$$\begin{aligned} r_{r_u} &= 8(531 + 373) / 42.25 \text{ } ^L_2 \\ &= 4.05 \text{ psi} \end{aligned}$$

$$r_{\text{avail}} = 4.05 - 0.26 - 0.10 \\ = 3.69 \text{ psi}$$

$$\text{Two times pressure load} = 2(1.1) = 2.2 \text{ psi}$$

$$3.69 \geq 2.2 \text{ psi}$$

Since the maximum response of an element is twice the blast load, this section is O.K.

(6) Calculate new section properties.

$$\text{new } A = 401 + 96 \times 1 \\ = 497 \text{ in}^2$$

$$\text{new } y_{\text{TC}} = 6.85 + 1.0 - 96(7.35)/497 \\ = 6.43 \text{ in}$$

$$\text{new } I_{\text{GC}} = 20985 + 401(1.42)^2 + 96(1)^3/12 + \\ 96(5.93)^2 \\ = 25180 \text{ in}^4$$

$$d = 7.85 + 14.15 \\ = 22.0 \text{ in}$$

$$p_{\text{PC}} = 4 \times 0.153 / (96 \times 22.0) \\ = 0.000290$$

(7) Calculate f_{PS} .

$$f_{\text{PS}} = f_{\text{PU}} \left[1 - \frac{[\gamma]_p (p_{\text{PC}})}{K_{\text{F1}}} \frac{f_{\text{DC}}}{f'_{\text{DC}}} \right]$$

$$[\gamma]_p = 0.40$$

$$K_{\text{F1}} = 0.85 - 0.05 (6250 - 4000)/1000 \\ = 0.7375$$

$$f_{\text{PS}} = 270,000 \left[1 - \frac{0.40 (.000290 \times 270,000/6250)}{.7375} \right] \\ = 268,167 \text{ psi}$$

(8) Calculate moment capacity of beam in loading phase.

$$a = \frac{A_{\text{PS}} f_{\text{PS}}}{.85 f'_{\text{DC}} b} \\ = \frac{0.612(268,167)}{.85(6250)96} \\ = 0.32 \text{ in}$$

$$c = a/K_{\text{F1}} \\ = 0.32/0.7375 \\ = 0.43 \text{ in} < 3.0 \text{ in thick flange}$$

Hence, the neutral axis is within the flange and the section can be analyzed as a rectangular section. If the neutral axis had extended into the web, a strain compatibility analysis would be required.

$$\begin{aligned} M_{ru} &= A_{ps} f_{ps} (d - a/2) \\ &= 0.612 \times 268.167 (22 - 0.32/2) \\ &= 3584 \text{ k-in} \end{aligned}$$

- (9) Determine ultimate resistance of section, considering beam simply-supported.

$$\begin{aligned} r_{ru} &= 8M_{ru} / L^2 \\ &= 8(3584) / (40 \times 12)^2 \\ &= 0.124 \text{ k/in} \end{aligned}$$

Resistance of section available to resist blast load is

$$\begin{aligned} r_{avail} &= r_{ru} - DL - LL \\ &= 124 - [497 \times 150/12^3] - (15 \times 8/12) \\ &= 124 - 43.1 - 10 \\ &= 70.9 \text{ lb/in} \end{aligned}$$

- (10) Calculate stiffness of section.

Elastic range stiffness

$$K_{E} = 384 E_{c} I_{a} / 5 L^4$$

Modulus of elasticity of concrete

$$\begin{aligned} E_{c} &= 33 W^{1.5} (f'_{c})^{1/2} \\ &= 33 (150)^{1.5} (5000)^{1/2} \\ &= 4,286,826 \text{ psi} \end{aligned}$$

Average moment of inertia

$$I_{a} = (I_{g} + I_{c}) / 2$$

$$I_{c} = n A_{ps} d^2 p (1 - (p p)^{1/2})$$

$$\begin{aligned} n &= E_{s} / E_{c} \\ &= 29,000,000 \\ &= \frac{29,000,000}{4,286,826} \\ &= 6.77 \end{aligned}$$

$$\begin{aligned} I_{c} &= (6.77) (0.612) (22.0)^2 [1 - (.000290)^{1/2}] \\ &= 1970 \text{ in}^4 \end{aligned}$$

$$\begin{aligned} I_{a} &= (25180 + 1970) / 2 \\ &= 13575 \text{ in}^4 \end{aligned}$$

$$\begin{aligned} K_{E} &= 384 (4286,826) 13575 / [5 \times (40 \times 12)^4] \\ &= 84.19 \text{ lb/in}^2 \end{aligned}$$

(11) Calculate effective mass of section.

Mass of element

$$m = [(497 \times 150/12 \text{ }^L3^J) / (32.2 \times 12)] \\ = 0.1116 \text{ lb-sec } ^L2^J / \text{in } ^L2^J$$

Load-mass factor for the elastic range

$$K_{rLM} = 0.79$$

Effective mass of element

$$m_{re} = mK_{rLM} \\ = 0.1116 \times 0.79 \\ = 0.0882 \text{ lb-sec } ^L2^J / \text{in } ^L2^J$$

(12) Calculate natural period of vibration

$$T_{rN} = 2[\pi] (m_{re} / K_{rE}) ^L1/2^J \\ = 2[\pi] (0.0882/84.19) ^L1/2^J \\ = 0.2034 \text{ sec} \\ = 203.4 \text{ ms}$$

(13) Determine section response from figure 6-7 of NAVFAC P- 397

$$B/r_{ru} = (1.1 \times 96) / 70.9 \\ = 1.49$$

$$T/T_{rN} = 43.9/203.4 \\ = 0.216$$

$$X_{rm} / X_{rE} = 1.0 \quad \text{O.K.}$$

Check rotation of beam

$$X = X_{rE} + X_{rDL} + X_{rLL} \\ = \frac{r_{avail}}{K_{rE}} + \frac{5(DL + LL)L^L4^J}{384EI_{ra}} \\ = \frac{70.9}{84.19} + \frac{5(43.1 + 10)(40 \times 12)^L4^J}{384(4,286,826)13575} \\ = 0.84 + 0.63 \\ = 1.47 \text{ in}$$

$$[\theta] = \tan^{-1} (2X/L) \\ = \tan^{-1} [2 \times 1.47 / (40 \times 12)] \\ = 0.35[\text{deg}] < 2[\text{deg}] \quad \text{O.K.}$$

(14) Check maximum reinforcement.

$$\begin{aligned} p_{ps} f_{ps} / f'_{dc} &= .000290 \times 268,167 / 6250 \\ &= 0.0124 \end{aligned}$$

$$\begin{aligned} 0.36K_{r1} &= 0.36 \times 0.7375 \\ &= 0.2655 \end{aligned}$$

$$0.0124 < \neq 0.2655 \quad \text{O.K.}$$

(15) Design for rebound. Reinforcing steel bars are now the main reinforcement.

From Figure 6-8 of NAVFAC P-397

$$r_{-j} / r_{u1} = 1.0$$

Required negative resistance

$$\begin{aligned} r_{-j}^{req} &= r_{-j} - DL \geq r_{avail} / 2 \\ &= 70.9 - 43.1 \\ &= 27.8 \text{ lb/in} \end{aligned}$$

$$\begin{aligned} r_{avail} / 2 &= 70.9 / 2 \\ &= 35.5 \text{ lb/in} \end{aligned}$$

$$27.8 < 35.5, \text{ therefore use } 35.5 \text{ lb/in}$$

Considering a single tee

$$\begin{aligned} r_{-j}^{req} &= 35.5 / 2 \\ &= 17.7 \text{ lb/in} \end{aligned}$$

$$\begin{aligned} d_{-j} &= 25 - 0.625 - 0.135 - 0.375 - 0.5 / 2 \\ &= 23.62 \text{ in} \end{aligned}$$

$$\begin{aligned} M_{-j} &= r_{-j} L^2 / 8 \\ &= 17.7 (40 \times 12)^2 / 8 \\ &= 509,760 \text{ in-lb} \end{aligned}$$

Concrete capacity available after accounting for prestressing effects:

$$\begin{aligned} 0.49 f'_{dc} &= 0.49 (6250) \\ &= 3062.5 \text{ psi} \end{aligned}$$

Assume $a = 2.0$ in

$$\begin{aligned} A_s &= M_{-j} / [f_{dy} (d_{-j} - a / 2)] \\ &= 509,760 / [66,000 (23.62 - 1.0)] \\ &= 0.341 \text{ in}^2 \end{aligned}$$

2.08-263

$$\begin{aligned}
 a &= A_s f_y / (0.49 f_c' b) \\
 &= 0.341 \times 66,000 / (3062.5 \times 3.75) \\
 &= 1.96 \text{ in} \quad \text{O.K.}
 \end{aligned}$$

Use two No. 4 in each stem.

$$A_s = 0.4 \text{ in}^2$$

Check maximum rebound reinforcement

$$A_s < / =$$

$$\begin{aligned}
 &\frac{0.49 f_c' K_{r1}}{f_y} \frac{(87,000 - 0.36 n f_c' b d)}{(87,000 - 0.36 n f_c' b d + f_y)} \\
 &= \frac{3062.5 \times 0.7375}{66,000} \\
 &\quad \frac{(87,000 - 0.36 \times 6.76 \times 6250)}{(87,000 - 0.36 \times 6.76 \times 6250 + 66,000)} \\
 &\quad \times (3.75 \times 23.62) \\
 &= 1.58 \text{ in}^2 > 0.40 \text{ in}^2 \quad \text{O.K.}
 \end{aligned}$$

(16) Design shear reinforcement.

Calculate shear at distance, d, from support

$$\begin{aligned}
 v_u &= r_u (L/2 - d) / b_w d \\
 &= 124 (20 \times 12 - 22.0) / (2 \times 4.75 \times 22.0) \\
 &= 129 \text{ psi} < 10 [\phi] (f_c')^{1/2} \\
 &= 10 \times 0.85 \times (5000)^{1/2} \\
 &= 601 \text{ psi} \quad \text{O.K.}
 \end{aligned}$$

$$\begin{aligned}
 v_c &= [\phi] [1.9 (f_c')^{1/2} + 2500 p] < / = \\
 &2.28 [\phi] (f_c')^{1/2} \\
 &= 0.85 [1.9 (5000)^{1/2} + 2500 \times .612 / (2 \times 4.75 \times \\
 &22.0)] \\
 &= 120 \text{ psi} < / = 2.28 (0.85) (5000)^{1/2} \\
 &< / = 137 \text{ psi} \quad \text{O.K.}
 \end{aligned}$$

$$A_s v = [(v_u - v_c) b_s] / [\phi] f_y$$

$$\begin{aligned}
 v_u - v_c &> / = v_c \\
 v_u - v_c &= 129 - 120 \\
 &= 9 \text{ psi} < v_c \text{ so use } v_c.
 \end{aligned}$$

Assume No. 3 stirrups,

$$\begin{aligned}
 A_s v &= 2 \times 0.11 \\
 &= 0.22 \text{ in}^2
 \end{aligned}$$

$$\begin{aligned}
 s &= (0.85 \times 60,000 \times 0.22) / (120 \times 4.75) \\
 &= 19.7 \text{ in}
 \end{aligned}$$

But $s < / = d/2 = 11.0 \text{ in}$

Use No. 3 stirrups at 11 inches in each stem

$$A_{fv} > 0.0015 bs = .0015 \times 4.75 \times 11 \\ = 0.08 \text{ in}^2 < 0.22 \text{ in}^2 \quad \text{O.K.}$$

Calculate shear at support:

$$V_{rd} = r_{u\gamma} L / 2 \\ = 124(40 \times 12) / 2 \\ = 29,760 \text{ lb}$$

Calculate maximum allowable direct shear

$$V_{rd} = 0.18 f'_{c\gamma} r_{dc\gamma} b_{f\gamma} d \\ = 0.18 (5,500) 4.75 (22.0) \\ = 103,455 \text{ lb} > 29,760 \text{ lb} \quad \text{O.K.}$$

(17) Check section for service loads.

This section as designed for blast loads is shown in Figure 70. Using the PCI design handbook and the latest ACI code, the section must be checked to make sure it is adequate for service loads.

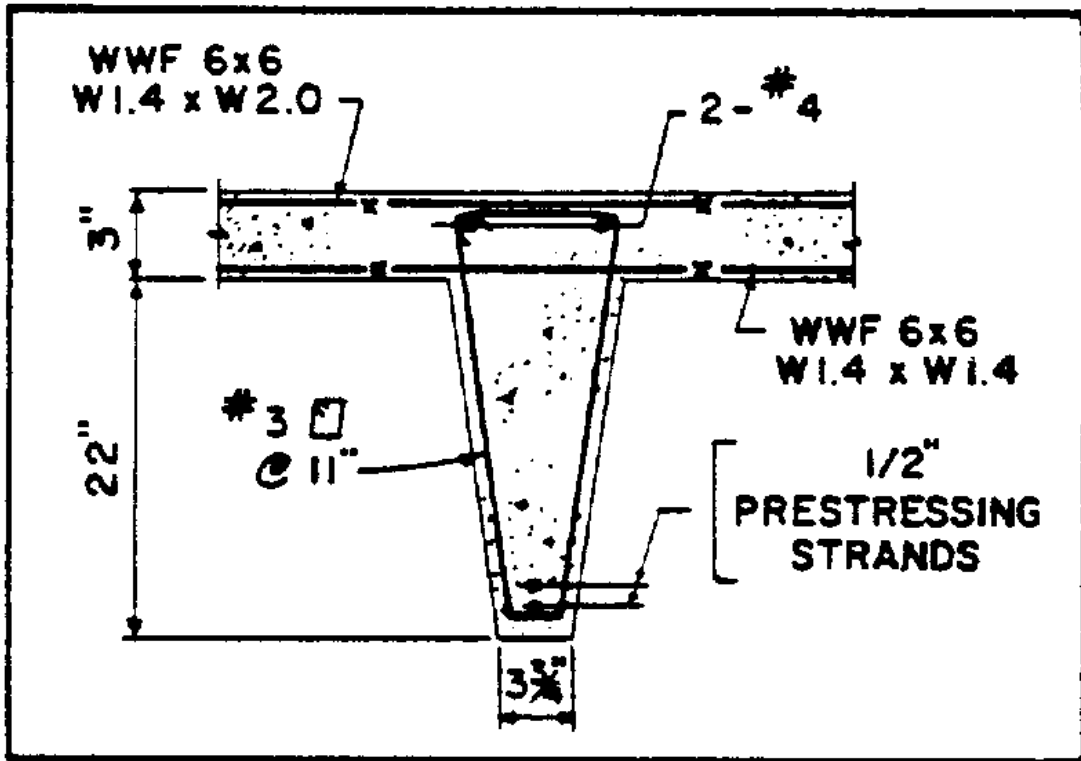

FIGURE 70

Required Reinforcement for Blast Loads

6. NOTATION.

- a - Depth of equivalent rectangular stress block, in
- A - Area of section, in²
- A_g - Area of gross section, in²
- A_n - Net area of section, in²
- A_{ps} - Area of prestressed reinforcement, in²
- A_s - Area of nonprestressed tension reinforcement, in²
- A_s' - Area of compression reinforcement, in²
- A_s^L - Area of rebound tension reinforcement, in²
- A_v - Area of shear reinforcement, in²
- b - Width of beam, in
- Unit width of wall or panel, in
- B - Pressure intensity, psi
- d - Distance from extreme compression fiber to centroid of nonprestressed tension reinforcement, in
- d_b - Distance between the centroids of the compression and tension reinforcement, in
- d_p - Distance from extreme compression fiber to centroid of prestressed reinforcement, in
- DIF - Dynamic increase factor
- DL - Dead load, psf
- e - Distance from centroid of section to centroid of prestressed reinforcement, in
- E - Modulus of elasticity, psi
- E_c - Modulus of elasticity of concrete, psi
- E_m - Modulus of elasticity of masonry units, psi
- E_s - Modulus of elasticity of steel, psi
- f_c' - Compressive strength of concrete, psi
- f_{dc}' - Dynamic compressive strength of concrete, psi
- f_{dy}' - Dynamic yield stress of steel, psi

f'_{cm}	-	Compressive strength of masonry units, psi
f_{ps}	-	Average stress in the prestressed reinforcement at ultimate load, psi
f_{pu}	-	Specified tensile strength of prestressing tendon, psi
f_{py}	-	Yield stress of prestressing tendon corresponding to a 1 percent elongation, psi
f_{se}	-	Effective stress in prestressed reinforcement after allowances for all prestress loss, psi
f_y	-	Static yield stress of reinforcement, psi
g	-	Acceleration due to gravity, ft/sec ²
h	-	Height of masonry wall
h'	-	Clear height between floor slab and roof slab
I	-	Moment of inertia, in ⁴
I_a	-	Average moment of inertia of gross and cracked sections, in ⁴
I_c	-	Moment of inertia of cracked section, in ⁴
I_g	-	Moment of inertia of gross section, in ⁴
I_n	-	Moment of inertia of net section, in ⁴
K_E	-	Equivalent elastic stiffness, psi
K_{LM}	-	Load-mass factor
K_1	-	0.85 for concrete strength up to 4000 psi, and is reduced 0.05 for each 1000 psi in excess of 4000 psi
L	-	Clear span, ft - Length of diagonal from one corner of masonry wall to midpoint on the opposite face
LL	-	Live load, psf
m_e	-	Effective unit elastic mass, lb-ms ² /in ²
M_u	-	Ultimate moment capacity, in-lb or in-lb/in
n	-	Number of glass pane tests
p	-	Ratio of nonprestressed tension reinforcement
p'	-	Compression reinforcement ratio
p_p	-	Prestressed reinforcement ratio
r^L_{-}	-	Maximum negative resistance, psi

r_{favail}	-	Resistance available for blast load, psi
r_{fu}	-	Ultimate unit resistance, psi
	-	Static test load, psi
\bar{r}_{fu}	-	Mean static test load, psi
R_{fu}	-	Total ultimate resistance, lb or lb/in
s	-	Spacing between stirrups, in
t_{fm}	-	Time to maximum deflection, ms
T	-	Duration of blast load, ms
	-	Thickness of masonry wall
T_N	-	Natural period of vibration, ms
v_{fc}	-	Concrete shear capacity, psi
v_{fu}	-	Ultimate shear stress, psi
V_{fd}	-	Direct shear force, lb
V_{fu}	-	Total applied design shear at $db/2$ from the support lb/in
w	-	Unit weight, lb/in ³
X_{fc}	-	Lateral deflection to which masonry wall develops no resistance
X_{DL}	-	Dead load deflection, in
X_{E}	-	Equivalent elastic deflection, in
X_{LL}	-	Live load deflection, in
X_{fm}	-	Maximum deflection, in
X_{f1}	-	Deflection at maximum ultimate resistance of masonry wall
y_{ct}	-	Distance from top of the section to centroid of section
[alpha]	-	Angle between inclined stirrups and longitudinal axis of member
[gamma] ρ	-	Factor for type of prestressing tendon
[sigma]	-	One standard deviation
[theta] ρ_{max}	-	Maximum support rotation, degrees
[phi]	-	Strength reduction factor
[mu] ρ_{max}	-	Maximum ductility ratio
[nu]	-	Poisson's ratio

SECTION 6. BLAST DOORS

1. SCOPE AND RELATED CRITERIA.

a. Scope. This section contains design criteria and procedures for solid steel and built-up blast doors. A good portion of the analytical procedures have been described earlier in this manual. Illustrative examples are provided for both the solid steel and built-up blast door.

b. Related Criteria. Current design criteria and procedures are contained in the following reports: Design of Steel Structures to Resist the Effects of HE Explosions by John J. Healey, et al., and Structures to Resist the Effects of Accidental Explosions, NAVFAC P-397. Experimental data on the behavior of steel doors under blast loading was collected during the ESKIMO Magazine Separation Test Series. The deformation criteria for structural steel elements and plates outlined in paragraph 1.b. of Section 4 in this manual also apply to both solid steel and built-up blast doors.

2. GENERAL. Blast doors can be divided into two categories depending on their use. They may be required to seal off openings from blast pressures (which is their primary use), or they may be required to resist primary fragment impact. Blast door exposure to fragment impact is a function of the door orientation to the source of an explosion and the nature of the donor system. Procedures for predicting the characteristics of primary fragments (such as impact velocity and size of fragment) are presented in NAVFAC P-397 and also in the report by John J. Healey, et al., Primary Fragment Characteristics and Impact Effects on Protective Barriers. Paragraph 11 of Section 2 of this manual also provides some information on this subject. Blast doors may also be grouped based on their method of opening, such as a) single-leaf, b) double-leaf, c) vertical lift, and d) horizontal sliding.

3. DESIGN CONSIDERATIONS. The results of the ESKIMO Test Series indicate that most blast doors fail because the door frame cannot transfer the shear on the door to the surrounding wall. As a result, the door remains intact and the force of the explosion shears the door casing and blows the door through the wall. As stated in Class Notes by Keenan, the ultimate resistance of the door must be tailored to the strength in shear of the door casing. Doors usually fail in rebound also, though they may be able to withstand the blast loading. It is imperative, therefore, that the door be designed for the rebound phase, keeping in mind that rebound forces are greater if the door remains elastic. On certain occasions, it may be required of the door to fail in rebound and in such cases, the door hinges have to be designed accordingly.

4. TYPES OF CONSTRUCTION.

a. General. The two basic types of blast door construction are solid steel plate and built-up doors. The choice of either a solid steel door or a built-up door must be based upon comparison of their relative economy, considering the particular blast pressure and fragment environment, size of door opening, strength of the door casing and boundary conditions of the door. Solid steel doors are used usually for high pressure ranges (50 psi or greater) and where fragment impact is critical. For low pressure ranges (10 psi or less) where fragment impact is not critical, the use of built-up doors is a practical arrangement.

b. Solid Steel Plate Door. A solid steel plate door is first sized for fragment penetration, if any, and then designed to resist the blast pressures as a two-way element. The design charts, equations and procedures are given in NAVFAC P-397. It was recommended in Healey's report to consider the solid steel plate door as a two-way element simply supported on all four sides. However, standard construction details (for the door) indicate that the bottom edge of the door provides little or no lateral support and as such, the door should be considered as a flat plate with three edges simply supported and the fourth edge free.

(1) As stated in paragraph 1.b of Section 4 of this manual, the door should be designed for a maximum (non-reusable) ductility ratio, $X_{Tm}/X_{TE} = 10$. A ductility ratio of 5 should be used for a reusable door. According to Keenan, the door should be designed for a maximum deflection equal to $0.13L$, where L is the clear horizontal span unless special requirements dictate a lesser deflection.

(2) Figure 71 shows a typical solid steel blast door. The direct load produced by the blast will be transmitted from the door to the supports by bearing, while reversal action of the door and the effects of negative pressure are transmitted to the door supports by several reversal bolts along the vertical edges. The reversal bolts eliminate the need to design the hinges for rebound. On wider doors, reversal bolts may be placed on the top and bottom door also to take advantage of possible two-way action of plate.

(3) A series of tests were performed on one-fifth scale models of missile cell blast doors fabricated from ASTM A36 mild steel plates. The results of the tests, which are published in the report by G. Warren titled Experimental Evaluation of Blast-Resistant Steel Doors, indicate the ductility ratios did not exceed 10 although measured deflections were well into the plastic range. The reserve capacity (usable ductility) underscores the significance of neglecting membrane action in the analysis.

(4) A problem solution is presented in paragraph 6.a of this section to illustrate the use of the design charts and procedures.

c. Built-up Door. A typical built-up blast door usually consists of a peripheral frame made from channels, with other horizontal channels serving as intermediate supports for the steel plate. All of the channel sections are connected by welding. The exterior cover plate, i.e., the plate facing the blast loads, is usually thicker than the interior plate. The mechanism for reversal loads is similar to that used for the solid steel door, except the hinges usually are designed to serve as the reversal bolts on one side of the door due to the lower magnitude of the blast pressures involved.

(1) Current design procedures, as stated in Healey's report, recommend that the exterior plate be designed as a continuous member supported by the transverse channels which, in turn, are designed as simply supported members, the applied blast load being equal to the blast pressures on the exterior plate. Certain conservative assumptions are made by this design methodology (as stated by Warren in Formulation of an Analysis Methodology for Blast-Resistant Steel Doors) which may result in an unnecessarily heavy and costly door.

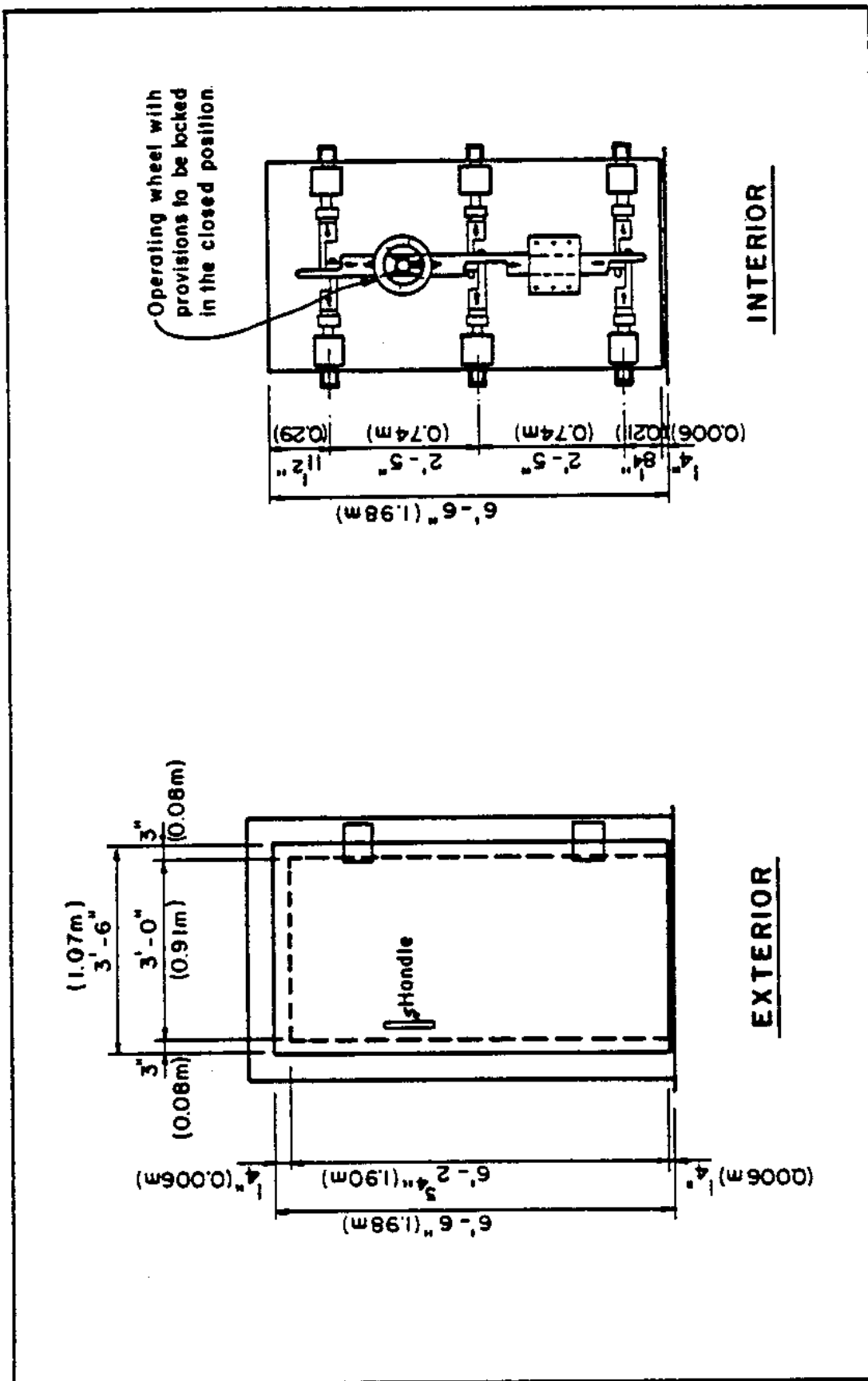

FIGURE 71
Steel Plate Blast Door

(2) However, as long as there is insufficient data to accurately describe the behavior of built-up doors (which is somewhere between one- and two-way element behavior), it is recommended by Keenan to design them as one-way elements if the configuration is similar to the typical built-up blast door described above. Figure 72 illustrates a typical built-up blast door and Figure 73 shows additional blast door details.

(3) Generally speaking, the design of blast doors using any of the current state-of-the-art methods, would result in a door with a capacity greater than that predicted by the analysis since the effects of membrane action are neglected. An analytical approach has been proposed by Warren et al. which might be useful for design of blast doors. The proposed method is essentially the same as that used in Computer Program SDOOR (Section 8 of this manual) except in the calculation of the built-up door properties. However, as stated by Warren, this approach must be validated by additional experimental and detailed analytical efforts.

(4) A problem solution is presented in paragraph 6.b, of this section, for predicting the response of a built-up door.

5. DOOR FRAME. The door frame should be designed to withstand the shear from the blast door and the loads induced by the hinges during the rebound phase of the door. The frame should also be able to transfer this shear to the surrounding walls and this is achieved through anchor rods and "cadwelds". The design of a typical door frame is best illustrated by an example which is presented in paragraph 6.c of this section.

6. EXAMPLE PROBLEMS.

a. Design of a Solid Steel Door.

Problem: Design a solid steel-plate blast door subjected to a pressure-time loading.

Given:

- (1) Pressure-time loading.
- (2) Design criteria ($[\theta]_{\max}$ and $[\mu]_{\max}$ for a reusable or non-reusable structure).
- (3) Structural configuration of the door including geometry and support conditions.
- (4) Properties of steel: Minimum yield strength, F_y , and dynamic increase factor, c .

Solution:

- (1) Select thickness of plate.
- (2) Calculate the elastic section modulus, S , and the plate section modulus, Z , of the plate.

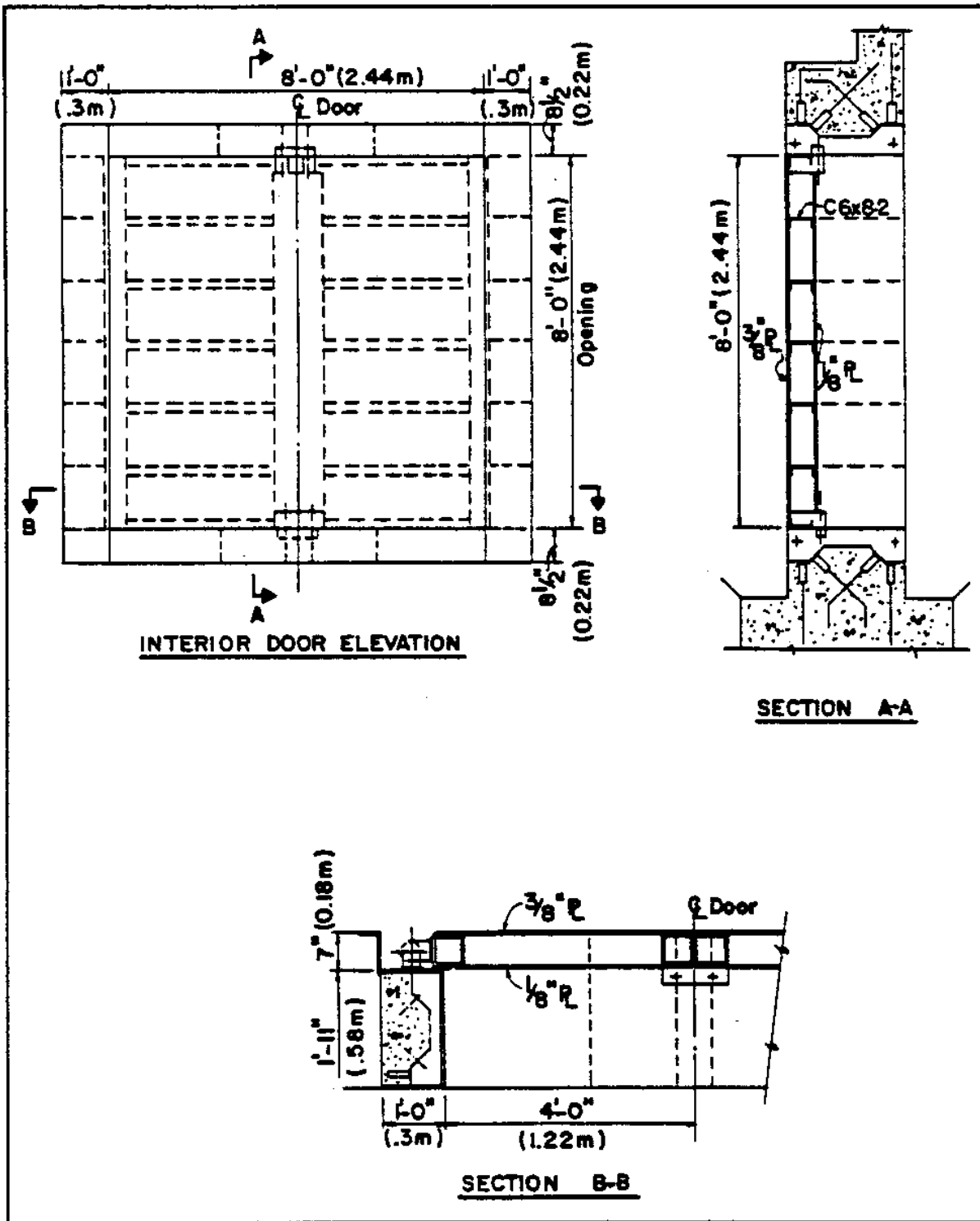

FIGURE 72
Built-up Steel Blast Door

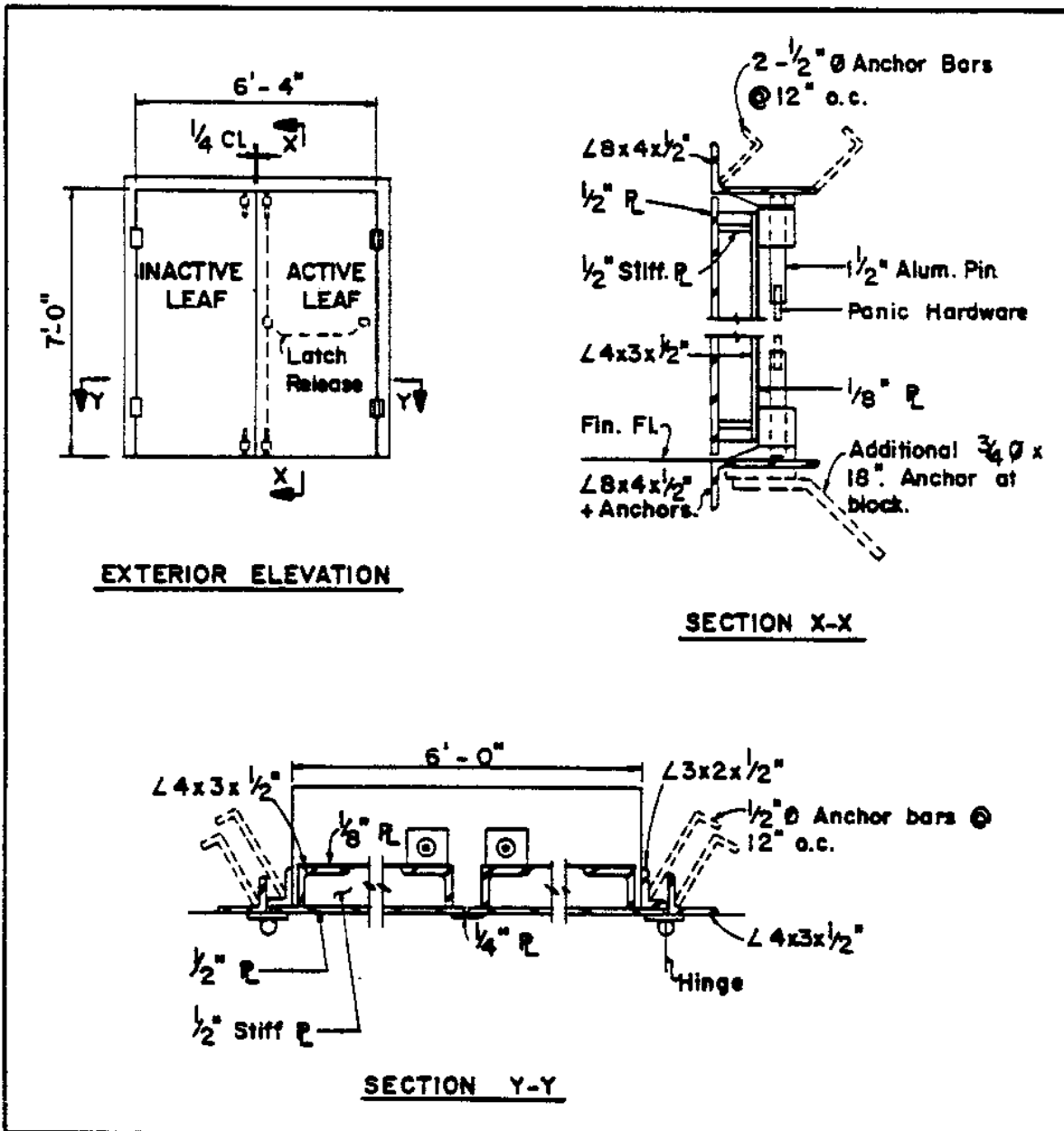

FIGURE 73
Double Leaf Blast Door Installed in a Concrete Structure

- (3) Calculate the design plastic moment, $M_{p\gamma}$, of the plate.
- (4) Calculate the flexural rigidity of the plate.
- (5) Calculate the elastic stiffness of the plate.
- (6) Calculate the ultimate unit resistance of the plate.
- (7) Calculate the equivalent elastic deflection, $X_{E\gamma}$, of the plate as given by $X_{E\gamma} = r_{u\gamma}/K_{E\gamma}$
- (8) Determine the load-mass factor, $K_{LM\gamma}$, and compute the effective unit mass, $m_{e\gamma}$.
- (9) Compute the natural period of vibration, $T_{N\gamma}$.
- (10) Determine the door response using the values of $B/r_{u\gamma}$ and $T/T_{N\gamma}$ using Figure 6-7 of NAVFAC P-397 to determine the values of $X_{m\gamma}/X_{E\gamma}$ and $[\theta]$. Compare with design criteria of Step 1. If these requirements are not satisfied, select another thickness and repeat Steps 1 to 10.
- (11) Determine the resistance of the door in the rebound phase. To do this, the hinge and bolt configurations have to be assumed.

Calculation:

Given:

- (1) Pressure-time loading as shown in Figure 74a.
- (2) Design criteria:
 - $[\mu]_{\max\gamma} = 5$ and
 - $[\theta]_{\max\gamma} = 2\text{deg.}$, whichever governs.
- (3) Structural configuration as shown in Figure 74b.
- (4) Steel properties:
 - ASTM A441 Grade 42
 - $F_{Y\gamma} = 42$ ksi
 - Dynamic increase factor, $c = 1.1$

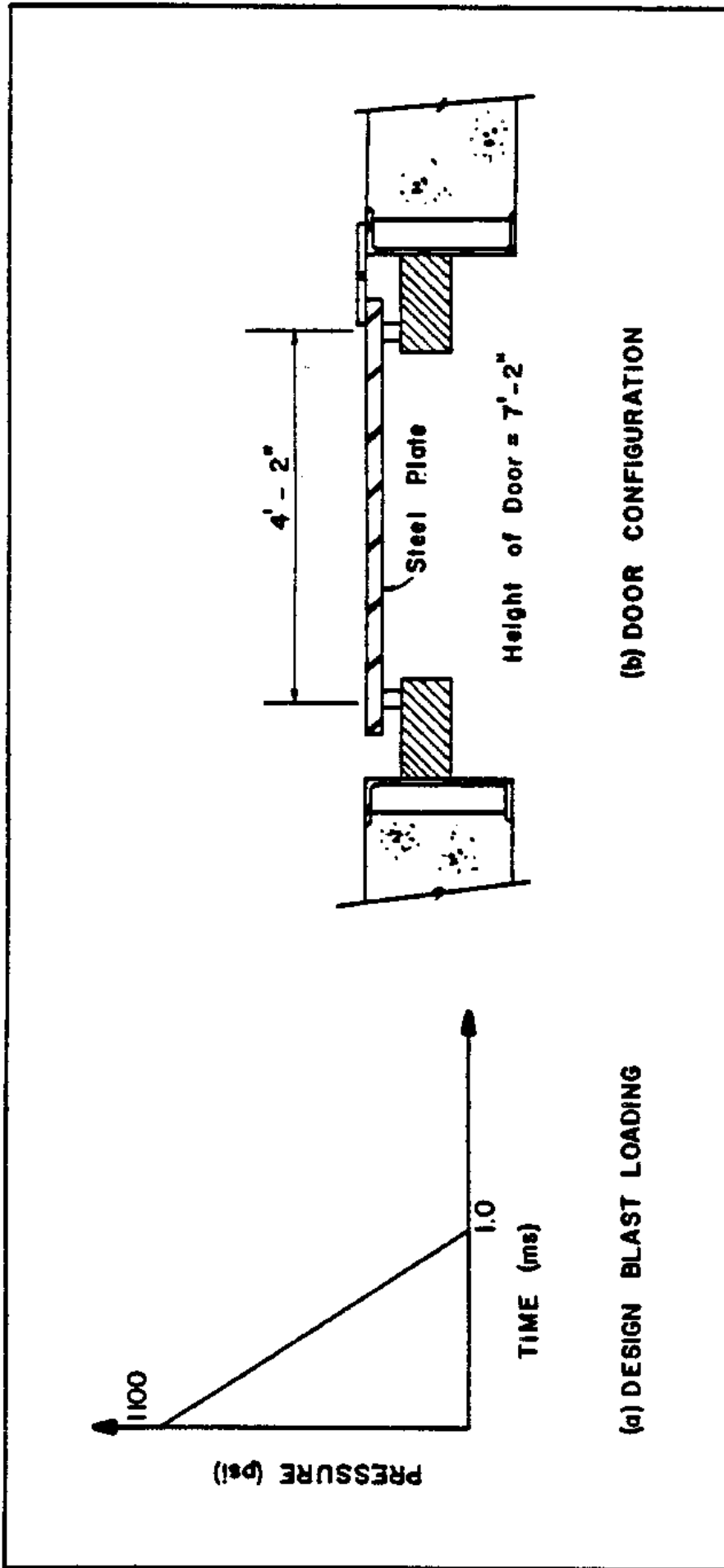

FIGURE 74
Pressure Loading and Door Configuration, Example 6a

Solution:

- (1) Assume a plate thickness of 2-1/2 inches.
- (2) Determine the elastic and plastic section moduli (per unit width).

$$\begin{aligned} S &= bd^2/6 \\ &= (1 \times 2.5^2)/6 \\ &= 1.04 \text{ in}^3/\text{in} \end{aligned}$$

$$\begin{aligned} Z &= bd^2/4 \\ &= (1 \times 2.5^2)/4 \\ &= 1.56 \text{ in}^3/\text{in} \end{aligned}$$

- (3) Calculate the design plastic moment, $M_{p\gamma}$, of the plate.

$$\begin{aligned} M_{p\gamma} &= F_{dy\gamma} (S + Z)/2 \\ &= 46.2(1.04 + 1.56)/2 \\ &= 60.06 \text{ K-in/in} \end{aligned}$$

- (4) Calculate the flexural rigidity of the plate.

$$\begin{aligned} D &= Et^3/12(1 - [\nu]^2) \\ &= (29 \times 10^6 \times 2.5^3)/12(1 - 0.3^2) \\ &= 41.5 \times 10^6 \text{ lb-in} \end{aligned}$$

- (5) Calculate the elastic stiffness of the plate, $K_{E\gamma}$.

From Figure 5-19 of NAVFAC P-397:

$$\begin{aligned} XD &= [\gamma]rH^4 \\ K_{E\gamma} &= r/X = D/[\gamma]H^4 \\ \text{For } H/L &= 0.58, [\gamma] = 0.0089 \end{aligned}$$

Therefore,

$$\begin{aligned} K_{E\gamma} &= (41.5 \times 10^6)/(0.0089 \times 50^4) \\ &= 746 \text{ psi/in} \end{aligned}$$

- (6) Calculate the ultimate unit resistance of the plate.

From Figure 5-11 of NAVFAC P-397:

$$\text{For } L/H = 86/50 = 1.72, x/L = 0.355$$

Therefore,

$$\begin{aligned} x &= 0.355(86) \\ &= 30.53 \text{ inches.} \end{aligned}$$

From Table 5-6 of NAVFAC P-397, ultimate unit resistance:

$$\begin{aligned} r_{u\gamma} &= 5(M_{HN\gamma} + M_{HP\gamma})/x^2 \\ M_{HN\gamma} &= 0; M_{HP\gamma} = M_{p\gamma} \\ r_{u\gamma} &= 5(60,060)/30.53^2 \\ &= 322.2 \text{ psi} \end{aligned}$$

- (7) Calculate the equivalent elastic deflection, $X_{rE\eta}$, of plate.

$$\begin{aligned} X_{rE\eta} &= r_{r\eta} / K_{rE\eta} \\ &= 322.2 / 746.1 \\ &= 0.432 \text{ in} \end{aligned}$$

- (8) Determine load-mass factor, $K_{rLM\eta}$, and compute the effective unit mass, $m_{re\eta}$.

$$\begin{aligned} K_{rLM\eta} &= (0.79 + 0.66) / 2 \\ &= 0.725 \end{aligned}$$

Unit mass of plate,

$$\begin{aligned} m &= w/g \\ &= [(490/1,728) (2.5) (10^6)] / (32.2 \times 12) \\ &= 0.001835 \times 10^6 \text{ lb-ms}^2 / \text{in}^2 \end{aligned}$$

Effective unit mass,

$$\begin{aligned} m_{re\eta} &= m K_{rLM\eta} \\ &= (0.001835 \times 10^6) (0.725) \\ &= 0.00133 \times 10^6 \text{ lb-ms}^2 / \text{in}^2 \end{aligned}$$

- (9) Calculate the natural period of vibration, $T_{rN\eta}$.

$$\begin{aligned} T_{rN\eta} &= 2[\pi] (m_{re\eta} / K_{rE\eta})^{1/2} \\ &= 2[\pi] [(0.00133 \times 10^6) / 746.1]^{1/2} \\ &= 8.39 \text{ ms} \end{aligned}$$

$$\begin{aligned} (10) \quad B/r_{r\eta} &= 1,100/322.2 \\ &= 3.41 \end{aligned}$$

$$\begin{aligned} T/T_{rN\eta} &= 1.0/8.39 \\ &= 0.12 \end{aligned}$$

From Figure 6-7 of NAVFAC P-397:

$$\begin{aligned} [\mu] &= X_{rm\eta} / X_{rE\eta} \\ &= 1.4 < 5 \quad \text{O.K.} \end{aligned}$$

Therefore,

$$\begin{aligned} X_{rm\eta} &= 1.4 (0.432) \\ &= 0.60 \text{ in} \end{aligned}$$

$$\begin{aligned} \tan [\theta] &= X_{rm\eta} / (L/2) \\ &= 0.6 / (50/2) \\ &= 0.024 \end{aligned}$$

$$\begin{aligned} [\theta] &= \tan^{-1} (0.024) \\ &= 1.38\text{deg.} < 2\text{deg.} \quad \text{O.K.} \end{aligned}$$

- (11) Assume the door has three hinges on one side and three "locking bolts" on the opposite side. Also assume that these hinges and bolts are close to each other such that the door can be assumed to be simply supported on these two sides for

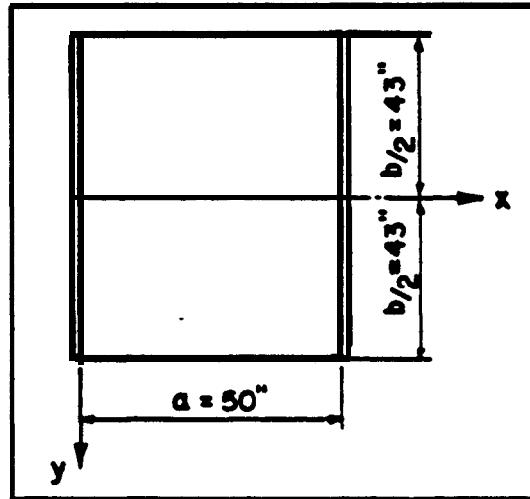

FIGURE 75

Door Plate Hinged on Opposite Sides

From Timoshenko, Theory of Plates and Sheets, Table 47:

$$\begin{aligned} b/a &= 86150 \\ &= 1.72 \end{aligned}$$

From reference table:

$$\begin{aligned} \alpha_1 &= 0.01295 \\ X &= \alpha r a^4 / D = 0.01295 r 50^4 / D \end{aligned}$$

$$\begin{aligned} K_g &= r/X = D/0.01295(50)^4 \\ &= (41.5 \times 10^6)/0.01295(50)^4 \text{ lb-in/in}^4 \\ &= 512.7 \text{ psi/in} \end{aligned}$$

Rebound resistance:

$$\begin{aligned} r^- &= 8M_p / L^2 \\ &= 8(60,060)/50^2 \\ &= 192.2 \text{ psi} \end{aligned}$$

b. Design of a Built-Up Steel Blast Door

Problem: Design a built-up steel blast door subjected to a pressure-time loading.

Given:

- (1) Pressure-time load.
- (2) Design criteria, $[\mu]_{\max}$ and $[\theta]_{\max}$ for a reusable or non-reusable structure (Section 4, paragraph 1.b.(2)).
- (3) Structural configuration of the door including geometry and support conditions.
- (4) Properties of steel used:
 - Minimum yield strength, F_{γ} , for door components.
 - Dynamic increase factor, c .

Solution:

- (1) Select the thickness of the plate.
- (2) Calculate the elastic section modulus, S , and the plastic section modulus, Z , of the plate.
- (3) Calculate the design plastic moment, M_{p} , of the plate.
- (4) Compute the ultimate dynamic shear, V_{p} .
- (5) Calculate maximum support shear, V , using a dynamic load factor of 1.0 and determine V/V_{p} .
 - If V/V_{p} is less than 0.67, use the plastic design moment as computed in Step 4.
 - If V/V_{p} is greater than 0.67, use Equation (97) to calculate the effective M_{p} .
- (6) Calculate the ultimate unit resistance of the section (Table 5-5 of NAVFAC P-397), using the equivalent plastic moment as obtained in Step 3 and a dynamic load factor of 1.0.
- (7) Determine the moment of inertia of the plate section.
- (8) Compute the equivalent elastic unit stiffness, K_{E} , of the plate section.
- (9) Calculate the equivalent elastic deflection, X_{E} , of the plate as given by $X_{\text{E}} = r_{\text{u}}/K_{\text{E}}$.

- (10) Determine the load-mass factor, K_{LM} , and compute the effective unit mass, m_{fe} .
- (11) Compute the natural period of vibration, T_{fn} .
- (12) Determine the door response using the values of B/r_{fu} and T/T_{fn} with Figure 6-7 of NAVFAC P-397 to determine the values of X_{fm}/X_{fe} and $[\theta]$. Compare the design criteria of Step 1. If these requirements are not satisfied, select another thickness and repeat Steps 2 to 13.
- (13) Design supporting flexural element considering composite action with the plate.
- (14) Calculate elastic and plastic section moduli of the combined section.
- (15) Follow the design procedure for a flexural element as described in the design examples of Section 4.

Calculation:

Given:

- (1) Pressure-time loading as shown in Figure 76a.
- (2) Design criteria:

Maximum ductility ratio, $[\mu]_{max} = 5$
 Maximum end rotation, $[\theta]_{max} = 2\text{deg.}$,
 whichever governs.

- (3) Structural configuration as shown in Figure 76b.

Note: This type of door configuration is suitable for low pressure range applications (5 to 15 psi).

- (4) Steel used: ASTM A36

Yield strength, $F_{ly} = 36 \text{ ksi}$
 Dynamic increase factor, $c = 1.1$

Hence, the dynamic yield strength:

$$F_{dy} = 1.1 \times 36 \\ = 39.6 \text{ ksi}$$

and the dynamic yield stress in shear:

$$F_{dv} = 0.55F_{dy} \\ = 0.55 \times 39.6 \\ = 21.78 \text{ ksi}$$

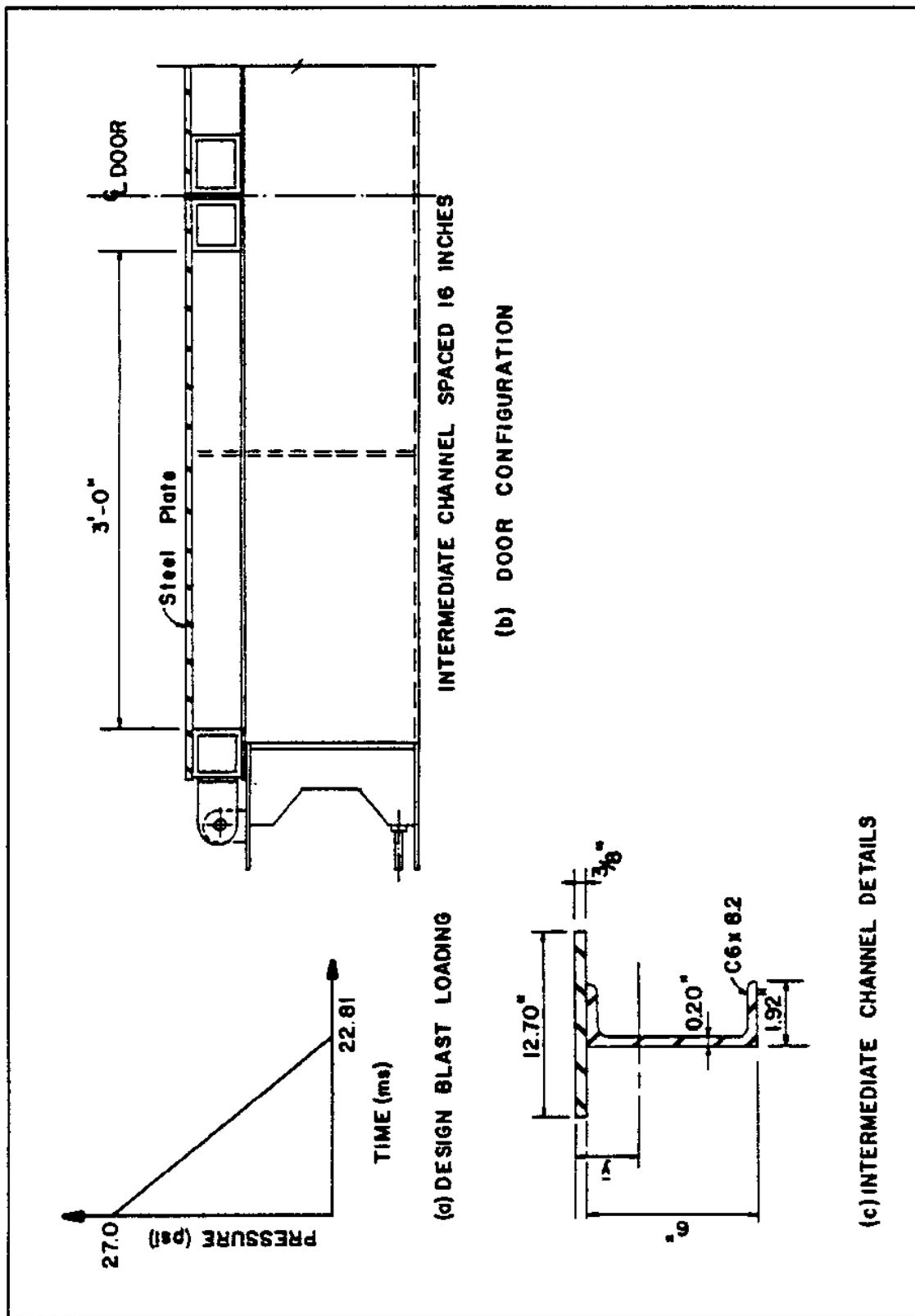

FIGURE 76
Pressure Loading and Door Configuration, Example 6b

Solution:

- (1) Assume a plate thickness of 3/8 inch.
- (2) Determine the elastic and plastic section moduli (per unit width).

$$\begin{aligned} S &= bd^2/6 \\ &= [1 \times (3/8)^2]/6 \\ &= 2.344 \times 10^{-2} \text{ in}^3/\text{in} \end{aligned}$$

$$\begin{aligned} Z &= bd^2/4 \\ &= [1 \times (3/8)^2]/4 \\ &= 3.516 \times 10^{-2} \text{ in}^3/\text{in} \end{aligned}$$

- (3) Calculate the design plastic moment, M_{p1} .

$$\begin{aligned} M_{p1} &= F_y(S + Z)/2 \\ &= 39.6[(2.344 \times 10^{-2}) + (3.516 \times 10^{-2})]/2 \\ &= 39.6 \times 2.93 \times 10^{-2} \\ &= 1.160 \text{ in-k/in} \end{aligned}$$

- (4) Calculate the dynamic ultimate shear capacity, V_{p1} , for a 1-inch width.

$$\begin{aligned} V_{p1} &= F_y A_w \\ &= 21.78 \times 1 \times 3/8 \\ &= 8.168 \text{ k/in} \end{aligned}$$

- (5) Evaluate the support shear and check the plate capacity. Assume DLF = 1.0.

$$\begin{aligned} V &= \text{DLF} \times B \times L/2 \\ &= 1.0(27.0)(15.75)(1)/2 \\ &= 212.6 \text{ lb/in or } 0.2126 \text{ k/in} \end{aligned}$$

$$\begin{aligned} V/V_{p1} &= 0.2126/8.168 \\ &= 0.0260 < 0.67 \end{aligned}$$

No reduction in equivalent plastic moment is necessary.

Note: When actual DLF is determined, reconsider Step 6.

- (6) Calculate the ultimate unit resistance, r_{u1} , assuming the plate is fixed-simply supported.

$$\begin{aligned} r_{u1} &= 12M_{p1}/L \\ &= 12(1.160)(10^3)/15.75 \\ &= 56.11 \text{ psi} \end{aligned}$$

(7) Compute the moment of inertia, I , for a 1-inch width.

$$\begin{aligned} I &= bd^3/12 \\ &= 1 \times (3/8)^3/12 \\ &= 0.004394 \text{ in}^4/\text{in} \end{aligned}$$

(8) Calculate the equivalent elastic stiffness, K_{FE} .

$$\begin{aligned} K_{FE} &= 160EI/bL^4 \\ &= 160(29)(10^6)(0.004394)/1(15.75)^4 \\ &= 331.3 \text{ psi/in} \end{aligned}$$

(9) Determine the equivalent elastic deflection, X_{FE} .

$$\begin{aligned} X_{FE} &= r_{u_1}/K_{FE} \\ &= 56.11/331.3 \\ &= 0.1694 \text{ in} \end{aligned}$$

(10) Calculate the effective mass of element.

Average of elastic and plastic transformation factors
from Table 10

$$\begin{aligned} K_{LM} &= (0.78 + 0.66)/2 \\ &= 0.72 \end{aligned}$$

Unit mass of element, m

$$\begin{aligned} m &= w/g \\ &= (3/8 \times 1 \times 1 \times 490 \times 10^6)/(1,728 \times 32.2 \times 12) \\ &= 275.2 \text{ lb-ms}^2/\text{in}^2 \end{aligned}$$

Effective unit mass of element, m_{Fe} (Section 6.6, NAVFAC
P-397)

$$\begin{aligned} m_{Fe} &= mK_{LM} \\ &= 275.2 \times 0.72 \\ &= 198.1 \text{ lb-ms}^2/\text{in}^2 \end{aligned}$$

(11) Calculate the natural period of vibration, T_{FN} .

$$\begin{aligned} T_{FN} &= 2[\pi](198.1/331.3)^{1/2} \\ &= 4.859 \text{ ms} \end{aligned}$$

(12) Determine the door response.

Peak overpressure, $B = 27.0 \text{ psi}$

Peak resistance, $r_{u_1} = 56.11 \text{ psi}$

Duration, $T = 22.81 \text{ ms}$

Natural period of vibration, $T_{FN} = 4.859 \text{ ms}$

$$\begin{aligned} B/r_{u\gamma} &= 27.0/56.11 \\ &= 0.4812 \end{aligned}$$

$$\begin{aligned} T/T_{rN\gamma} &= 22.81/4.859 \\ &= 4.694 \end{aligned}$$

From Figure 6-7, NAVFAC P-397:

$$\begin{aligned} [\mu] &= X_{rM\gamma}/X_{rE\gamma} \\ &= 1.2, \text{ so it satisfies the ductility ratio} \\ &\text{criteria.} \end{aligned}$$

Since the response is elastic, determine the DLF. Refer to Figure 5.19 of Manual EM 1110-345-415.

$$\text{DLF} = 0.98 \text{ for } T/T_{rN\gamma} = 0.349$$

Hence,

$$\begin{aligned} X_{rM\gamma} &= 0.98(27.0)(0.1694)/56.11 \\ &= 0.0799 \text{ in} \end{aligned}$$

$$\begin{aligned} \tan [\theta] &= X_{rM\gamma}/(L/2) \\ &= 0.0799/(15.75/2) \\ &= 0.01015 \end{aligned}$$

$$[\theta] = 0.581\text{deg.} < 2\text{deg.} \quad \text{O.K.}$$

(13) Design of supporting flexural element.

Assume a channel C6 x 8.2 and attach to plate as shown in Figure 77.

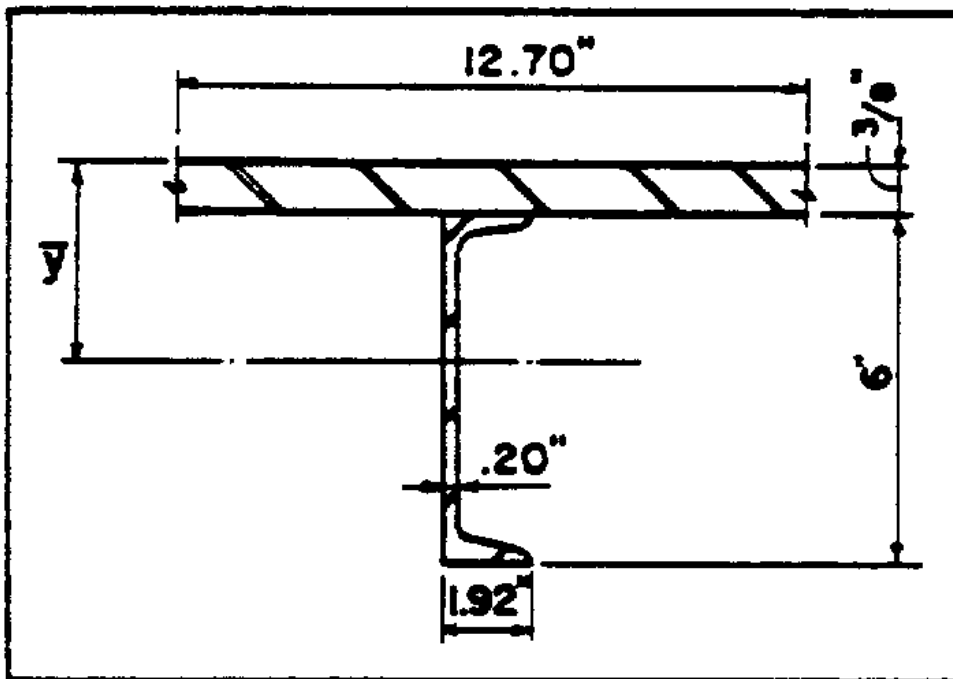

FIGURE 77

Built - Up Cross - Section

Calculate the effective width of plate from AISC Manual of Steel Construction, Appendix C, Equation C3-1.

$$\begin{aligned} b_{\text{eff}} &= (253t) / (f_y) \left[1 - 50.3 / (b/t) (f_y) \right] \\ &= 253(3/8) / 36 \left[1 - 50.3 / (16 / (3/8)) (36) \right] \\ &= 12.70 \text{ in} \end{aligned}$$

- (14) Calculate the elastic and plastic section moduli of the combined section.

Let \bar{y} be the distance of c.g. of the combined section from the outside edge of the plate as shown in Figure 77.

$$\begin{aligned} \bar{y} &= \frac{(12.70 \times 3/8 \times 3/16) + (6 + 3/8 - 3) \times 2.40}{(12.70 \times 3/8) + 2.40} \\ &= 1.256 \text{ inches} \end{aligned}$$

Let y_p be the distance to the N.A. of the combined section for full plasticity.

$$\begin{aligned} 12.70 y_p &= 2.40 + 12.70(3/8 - y_p) \\ y_p &= 7.163 / 25.4 \\ &= 0.282 \text{ in.} \end{aligned}$$

$$\begin{aligned} I &= [12.70 \times (3/8)^3] / 12 + 12.70(3/8) \times (1.256 - 3/16)^2 + 13.1 + 2.40 \times (3/8 + 3 - 1.256)^2 \\ &= 29.37 \text{ in}^4 \end{aligned}$$

Hence,

$$\begin{aligned} S_{\text{min}} &= 29.37 / (6.375 - 1.256) \\ &= 5.737 \text{ in}^3 \end{aligned}$$

$$\begin{aligned} Z &= 12.70(0.282)^2 / 2 + 12.70(3/8 - 0.282)^2 / 2 \\ &\quad + 2.40(6.375 - 3 - 0.282) \\ &= 7.983 \text{ in}^3 \end{aligned}$$

- (15) $M_p = 39.6(5.737 + 7.983) / 2$
 $= 271.6 \text{ in-k}$

Calculate the ultimate dynamic shear capacity, V_p .

$$\begin{aligned} V_p &= F_u A_w \\ &= 21.78(4.375 \times 0.20) \\ &= 19.06 \text{ k} \end{aligned}$$

Calculate support shear and check shear capacity.

$$L = 3 \text{ ft or } 36 \text{ in}$$

$$\begin{aligned} V &= (27.0 \times 16.0 \times 36) / 2 \\ &= 7,776 \text{ lb} \end{aligned}$$

$$7.776 \text{ k} < V_p \quad \text{O.K.}$$

Calculate the ultimate resistance, $r_{u\gamma}$, assuming the angle to be simply supported at both ends:

$$\begin{aligned} r_{u\gamma} &= 8M_{p\gamma}/L^2 \\ &= 8(271.6)(1,000)/36^2 \\ &= 1,676 \text{ lb/in} \end{aligned}$$

Calculate the unit elastic stiffness, $K_{E\gamma}$:

$$\begin{aligned} K_{E\gamma} &= 384EI/5L^4 \\ &= 384(29)(10^6)(29.37)/5(36^4) \\ &= 38,945 \text{ lb/in}^2 \end{aligned}$$

Determine the equivalent elastic deflection, $X_{E\gamma}$:

$$\begin{aligned} X_{E\gamma} &= r_{u\gamma}/K_{E\gamma} \\ &= 1,676/38,945 \\ &= 0.04304 \text{ in} \end{aligned}$$

Calculate the effective mass of the element.

Average of elastic and plastic transformation factors;

$$\begin{aligned} K_{LM\gamma} &= (0.79 + 0.66)/2 \\ &= 0.725 \end{aligned}$$

$$\begin{aligned} w &= 8.2/12 + (3/8)(16)(490)/1,728 \\ &= (0.6833 + 1.701) \\ &= 2.385 \text{ lb/in} \end{aligned}$$

Effective unit mass of element:

$$\begin{aligned} m_{e\gamma} &= 0.725 \times 2.385(10^6)/(32.2 \times 12) \\ &= 4,475 \text{ lb-msec}^2/\text{in}^2 \end{aligned}$$

Calculate the natural period of vibration, $T_{N\gamma}$

$$\begin{aligned} T_{N\gamma} &= 2[\pi](4,475/38,945)^{1/2} \\ &= 2.13 \text{ ms} \end{aligned}$$

Determine the response parameters (Fig. 6-7, NAVFAC P-397)

$$\begin{aligned} \text{Peak overpressure,} \\ B &= 27.0 \times 16 \\ &= 432 \text{ lb/in} \end{aligned}$$

$$\begin{aligned} \text{Peak resistance,} \\ r_{u\gamma} &= 1,676 \text{ lb/in} \end{aligned}$$

$$\text{Duration, } T = 22.81 \text{ ms}$$

$$\begin{aligned} \text{Natural period of vibration,} \\ T_{N\gamma} &= 2.13 \text{ msec} \end{aligned}$$

$$\begin{aligned} B/r_{\mu} &= 432/1,676 \\ &= 0.2578 \end{aligned}$$

$$\begin{aligned} T/T_{N} &= 22.81/2.13 \\ &= 10.71 \end{aligned}$$

From Figure 6-7, NAVFAC P-397:

$$\begin{aligned} [\mu] &= X_{r\mu} / X_{rE} \\ &= 1 < 3 \quad \text{O.K.} \end{aligned}$$

$$\begin{aligned} X_{r\mu} &= 1 \times 0.04304 \\ &= 0.04304 \text{ in} \end{aligned}$$

$$\begin{aligned} \tan [\theta] &= X_{r\mu} / (L/2) \\ &= 0.04304 / (36/2) \\ &= 0.002391 \end{aligned}$$

$$[\theta] = 0.137\text{deg.} < 1\text{deg.} \quad \text{O.K.}$$

Check stresses at the connecting point.

$$\begin{aligned} [\sigma] &= My/I \\ &= 271.6(10^3) (1.256 - 0.375) / 29.37 \\ &= 8,147 \text{ psi} \end{aligned}$$

$$\begin{aligned} [\tau] &= VQ/Ib \\ &= 7.776(10^3) (12.70) (3/8) (1.256 - 0.375/2) / \\ &\quad 29.37(0.200) \\ &= 6,736 \text{ psi} \end{aligned}$$

Effective stress at the section

$$\begin{aligned} ([\sigma]^2 + [\tau]^2)^{1/2} &= (8,147^2 + \\ &\quad 6,736^2)^{1/2} \\ &= 10,571 \text{ psi} < \\ &\quad 36,000 \text{ psi O.K.} \end{aligned}$$

c. Design of Door Frame

Problem: Design the frame of the blast door described in Figure 74, Example 6.a.

Given:

- (1) Same parameters as in Example 6.a, Figure 74.
- (2) Size of door opening.
- (3) Surrounding wall thickness.
- (4) Type of steel

Solution:

- (1) Determine reactions around door opening.
- (2) Select plate thickness.
- (3) Select stiffener size and spacing.
- (4) Check adequacy of section for door reactions.
- (5) Determine loads on each hinge during the rebound phase. These loads should be available in the design calculations of the blast door.
- (6) Check stresses on frame due to these hinge loads.
- (7) Determine size of anchor rods (or "cadwelds"). Use Equation 5-13 of NAVFAC P-397.

Calculation:

Given: Door parameters

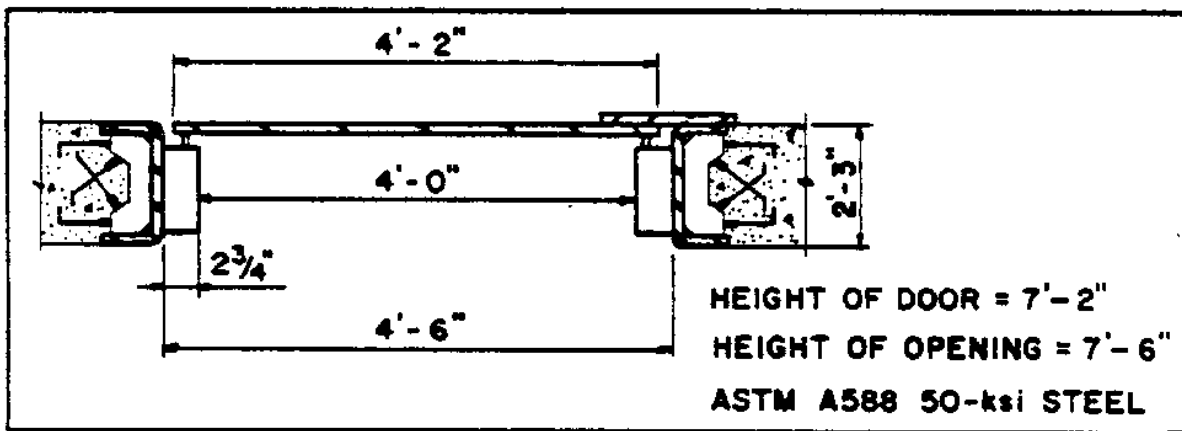

FIGURE 78
Cross - Section of Blast Door

Solution:

- (1) Determine reactions around door opening.

The ultimate unit resistance of door,
 $r_{u\gamma} = 322.2 \text{ psi}$

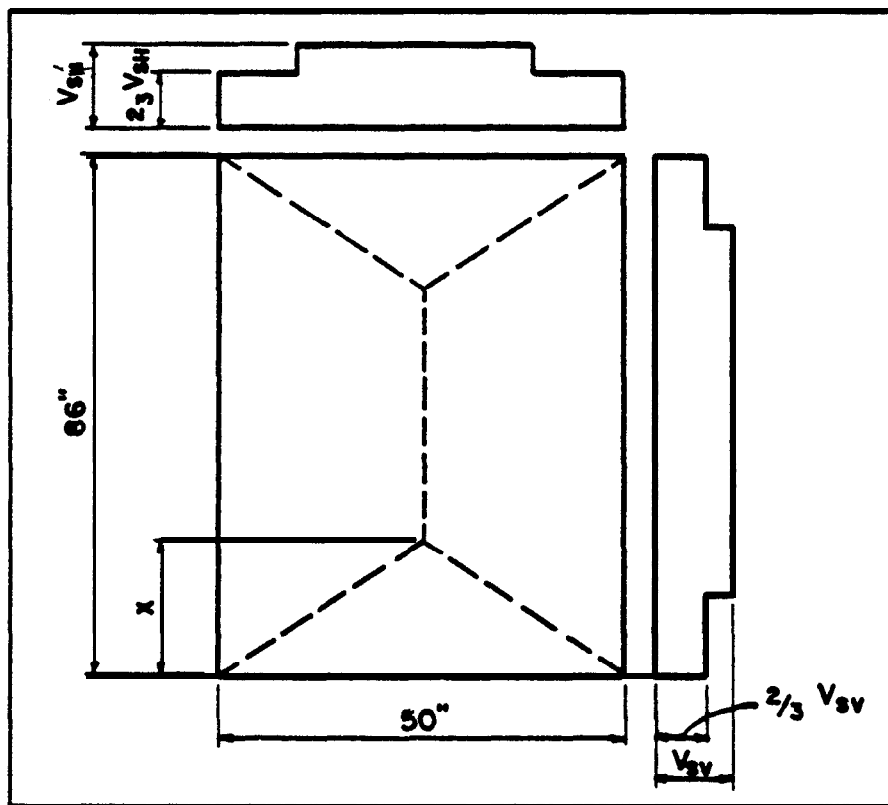

FIGURE 79

Location of Yield Lines on Door Plate

Use Figure 5-11 of NAVFAC P-397 to determine the value of x ; i.e., locate yield lines.

$$\begin{aligned} \text{For } L/H &= 86/50 \\ &= 1.72 \end{aligned}$$

$$x/L = 0.355$$

Therefore,

$$\begin{aligned} x &= 0.355(86) \\ &= 30.5 \text{ in c } L/2 \text{ i: } 43 \text{ inches} \end{aligned}$$

Use Table S-14 to determine horizontal and vertical shears.

$$\begin{aligned} V_{sv} &= 3r_x x/5 \\ &= 3(322.2)(30.5)/5 \\ &= 5,896.3 \text{ lb/in} \end{aligned}$$

$$\begin{aligned} V_{sv} &= 3r_u H(1 - x/L)/2(3 - x/L) \\ &= 3(322.2)(50)(1 - 30.5/86)/2(3 - 30.5/86) \\ &= 5,895.2 \text{ lb/in} \end{aligned}$$

Design load is taken as 5,896 lb/in

- (2) Try 1/2-inch bent plate.
- (3) Try 3/8-inch stiffener plate at 10 inches o.c.

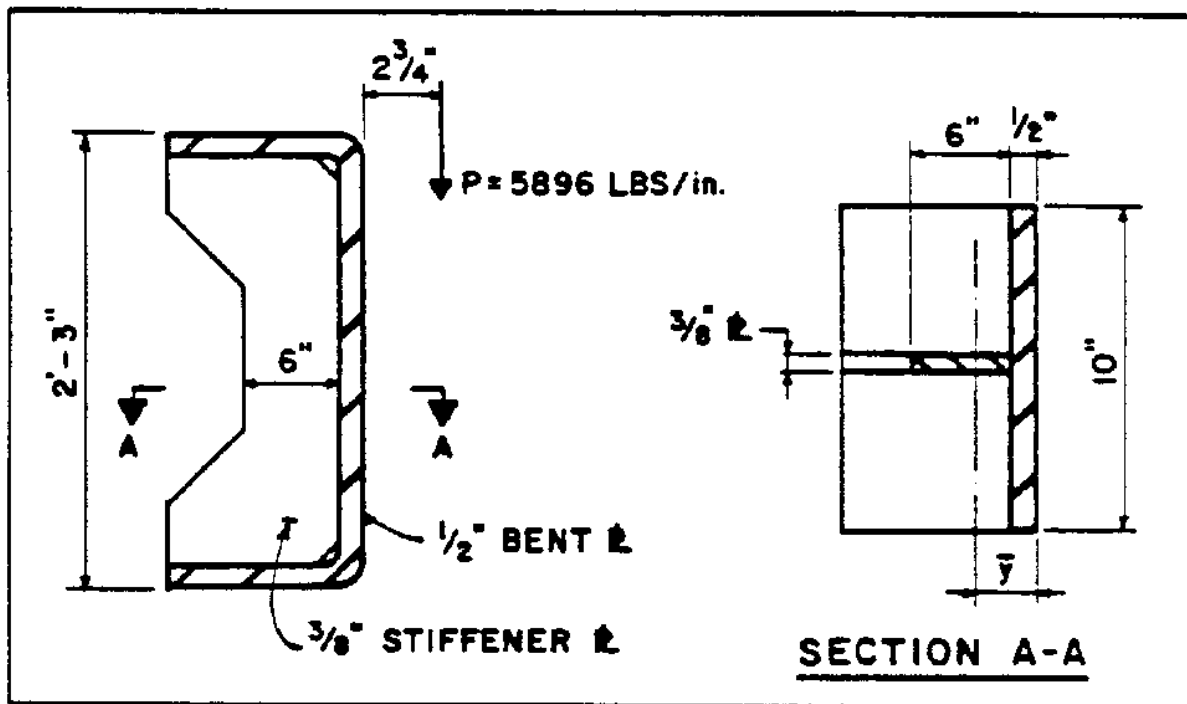

FIGURE 80
Details of Stiffener Plate

- (4) Check adequacy of section for door reactions.

$$A = 10(1/2) + (3/8)6$$

$$= 7.25 \text{ in}^2$$

$$y = (10 \times 1/2 \times 1/4 + 6 \times 3/8 \times 3.5) / 7.25$$

$$= 1.26 \text{ in}$$

$$I = (10 \times 0.5) (1.26 - 0.25)^2 + 1/12 \times 10 \times$$

$$(1/2)^3 + (6 \times 0.375) (3.5 - 1.26)^2 +$$

$$(1/12 \times 3/8 \times 6^3)$$

$$= 23.24 \text{ in}^4$$

$$S_{FB} = 23.24 / (6.5 - 1.26)$$

$$= 4.44 \text{ in}^3$$

$$\begin{aligned} S_{\Gamma T} &= 23.24/1.26 \\ &= 18.45 \text{ in}^3 \end{aligned}$$

Applied moment,

$$\begin{aligned} M &= Pe \\ &= 5,896 \text{ lb/in} \times 10 \text{ in} \times (2.75 + 1.26) \text{ in} \\ &= 236,429.6 \text{ in-lb or } 236.4 \text{ in-k} \end{aligned}$$

Plastic moment capacity,

$$\begin{aligned} M_{\Gamma P} &= F_{\Gamma d} S \\ &= 1.1(50)(4.44) \\ &= 244.2 \text{ in-k} \end{aligned}$$

$$M_{\Gamma P} > M \quad \text{O.K.}$$

Consider section as column of length 2'-3" subject to combined axial load bending moment (see Equation 2.4-3 AISC Manual).

$$P/P_y + M/1.18M_{\Gamma P} < / = 1.0 \quad M < / = M_{\Gamma P}$$

$$\begin{aligned} P_{\Gamma y} &= AF_{\Gamma d} \\ &= 7.25(50 \times 1.1) \\ &= 398.8 \text{ k} \end{aligned}$$

$$\begin{aligned} P &= 5,896 \times 10 \\ &= 59 \text{ k} \end{aligned}$$

$$\begin{aligned} P/P_{\Gamma y} + M/1.18M_{\Gamma P} &= 59/398.8 + 236.4/1.18(244.2) \\ &= 0.97 < 1.0 \quad \text{O.K.} \end{aligned}$$

Section is O.K. for door reaction.

- (5) Determine the loads on each hinge during rebound phase.

From Example 6.a, rebound resistance,

$$r_{\Gamma d} = 192.2 \text{ psi}$$

$$\begin{aligned} \text{Total load on door} &= 192.2 \times 86 \times 50 \\ &= 826.5 \text{ k} \end{aligned}$$

This load is picked up by 3 hinges and 3 "locking bolts".

$$\begin{aligned} \text{Load per hinge/bolt} &= 826.5/6 \\ &= 137.75 \text{ k} = 138 \text{ k} \end{aligned}$$

- (6) The stiffeners should be in such a location so as to pick-up the loads of the hinges. It is advisable to locate a stiffener directly underneath a hinge. The size of the welds connecting the stiffener plates to the bent plate should be determined on this basis.

(7) Determine size of anchor bars.

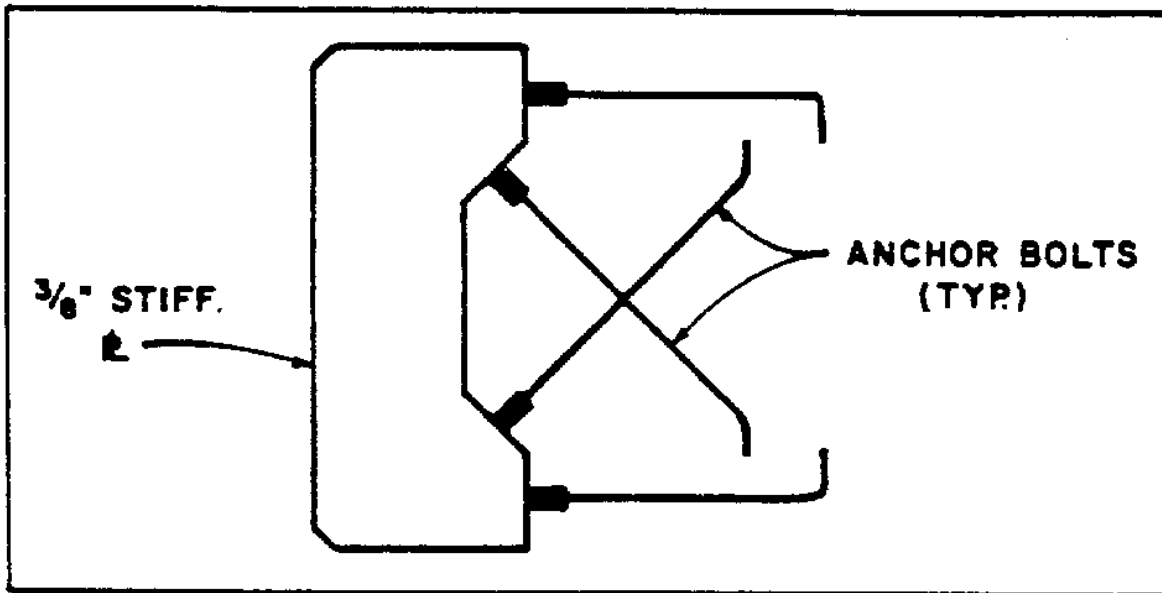

FIGURE 81
Configuration of Anchor Bars

Diagonal bars:

From NAVFAC P-397, Equation 5-13,
 $A_{rd} = V_{rs} b / f_{rs} \sin [\alpha]$

Support shear,
 $V_{rs} = 5,896 \text{ lb/in}$

Spacing of stiffeners,
 $b = 10 \text{ inches}$

Yield stress of steel,
 $f_{rs} = 60,000 \text{ psi}$

Angle between diagonal and horizontal
 $= 45\text{deg.}$

Therefore, area of diagonal bars
 $A_{rd} = 5,896(10) / 60,000(0.707)$
 $= 1.39 \text{ in}^2$

Area of single bar $= 1.39/2$
 $= 0.70 \text{ in}^2$

Use No. 8 bars with area $= 0.79 \text{ in}^2$

Horizontal bar:

Design for horizontal component of forces in diagonals. In this case, use 0.707 x required area of diagonal bar.

$$\begin{aligned} \text{Required area of horizontal bar} &= 0.707 \times 0.70 \\ &= 0.49 \text{ in}^2 \end{aligned}$$

Use No. 7 bars with area = 0.60 in²

8. NOTATION

a	-	Length of plate, in
A	-	Area of section, in ²
A _w	-	Area of web, in ²
b	-	Width of section, in
	-	Height of plate, in
b _e	-	Effective width of plate, in
B	-	Pressure intensity, psi
c	-	Dynamic increase factor
d	-	Depth of section, in
D	-	Flexural rigidity of plate, lb-in
DLF	-	Dynamic load factor
e	-	Eccentricity
F _{dy}	-	Dynamic yield stress of steel, ksi
F _{dv}	-	Dynamic yield stress in shear, ksi
F _y	-	Static yield stress of steel, psi
g	-	Acceleration due to gravity, ft/s ²
H	-	Height of plate, in
I	-	Moment of inertia, in ⁴ /in
K _E	-	Equivalent elastic stiffness, lb/in ²
K _{LM}	-	Load-mass factor
L	-	Length of plate, in

m	-	Unit mass of plate, $\text{lb}\cdot\text{ms}^2/\text{in}^2$ or $\text{lb}\cdot\text{ms}^2/\text{in}$
m_{re}	-	Effective elastic unit of mass of plate, $\text{lb}\cdot\text{ms}^2/\text{in}^2$ or $\text{lb}\cdot\text{ms}^2/\text{in}$
M	-	Applied moment, $\text{in}\cdot\text{k}$
M_{HN}	-	Negative moment capacity in the horizontal direction, $\text{in}\cdot\text{k}/\text{in}$ or $\text{in}\cdot\text{k}$
M_{HP}	-	Positive moment capacity in the horizontal direction, $\text{in}\cdot\text{k}/\text{in}$ or $\text{in}\cdot\text{k}$
M_{P}	-	Plastic moment capacity, $\text{in}\cdot\text{k}/\text{in}$ or $\text{in}\cdot\text{k}$
P	-	Applied axial load, k
P_{Y}	-	Plastic axial load, k
r_{L}	-	Maximum negative resistance, psi
r_{U}	-	Ultimate unit resistance, psi
S	-	Elastic section modulus, in^3/in
S_{B}	-	Elastic section modulus referred to the bottom of the section, in^3
S_{T}	-	Elastic section modulus referred to the top of the section, in^3
t	-	Thickness of plate, in
T	-	Load duration, ms
T_{N}	-	Natural period of vibration, ms
V	-	Maximum support shear, k/in or lb
V_{P}	-	Ultimate dynamic shear, lb/in
V_{S}	-	Support shear, lb/in
V_{sh}	-	Horizontal support shear, lb/in
V_{sv}	-	Vertical support shear, lb/in
w	-	Unit weight, lb/in
x	-	Horizontal distance to yield line, in
X_{E}	-	Equivalent elastic deflection, in
X_{m}	-	Maximum deflection, in
y	-	Distance from outside edge of plate to center of gravity of section, in
Y_{P}	-	Distance to plastic neutral axis, in

Z	-	Plastic section modulus, in ³ /in
[theta] _{max}	-	Maximum support rotation, degrees
[mu] _{max}	-	Maximum ductility ratio
[gamma]	-	Deflection coefficient
[gamma] ₁	-	Deflection coefficient
[alpha]	-	Angle between diagonal bar and horizontal
[sigma]	-	Stress due to bending moment, psi
[tau]	-	Stress due to shear, psi

SECTION 7. FOUNDATIONS

1. INTRODUCTION. The structure's foundation is designed for both conventional loads (dead and live) and blast load conditions.

a. Conventional Loads. Procedures of designing foundations for conventional loads are adequately described in several textbooks, two of which are Design of Concrete Structures, by Winter and Nilson, and Foundation Engineering Handbook, edited by Winterkorn and Fang.

b. Blast Loads. The design for foundations for protective structures is based on providing a means of transmitting the blast loads from the structures to the underlying soil, without a soil shear failure (i.e., a plastic flow or a lateral displacement of soil from beneath the foundation), or causing excessive total settlements of the soil or differential settlements of various parts of the structure under the impulse loads. To limit settlements, the load on the soil should be transmitted to a soil stratum of sufficient stiffness and the load should also be spread over a sufficiently large area.

(1) In designing a structure's foundation for blast loads, an analysis has to be performed to determine if the foundation will slide or overturn, by calculating its peak response and the time history of the bearing pressures acting on it. Consider, for example, a retaining wall under the action of blast-induced forces (Figure 82). The foundation will tend to slide in the direction of the blast loads and rotate also. It can be seen that the structure's foundation is subjected to horizontal frictional forces as the building tends to slide and to active bearing pressures as the structure tries to rotate, thus concentrating the vertical load toward the rear end of the foundation. The changing load distribution is illustrated in Figure 82. If the overturning moment about the edge of the foundation exceeds the stabilizing moment, then the structure will rotate until the stabilizing moment becomes equal to, or greater than, the overturning moment. Unless the resistance to overturning is developed fairly rapidly, the structure will overturn. The structure will also slide if the horizontal frictional and passive earth forces are exceeded.

(2) Sliding and overturning of the structure reduce the resistance needed by the structure to resist the blast loads. The extent to which the structure can resist sliding and overturning will depend on the capacity of the structure for utilizing vertical dead, live and blast loads to prevent such motion.

2. FOUNDATION DESIGN.

a. Introduction. Design procedures and criteria vary according to the type of foundation, the use of the structure and the design loads. A foundation for a radar tower, for example, must provide stability against excessive motions and rocking, whereas the foundation for a rotating or reciprocating machine has to be designed against progressive settlement of the underlying soil.

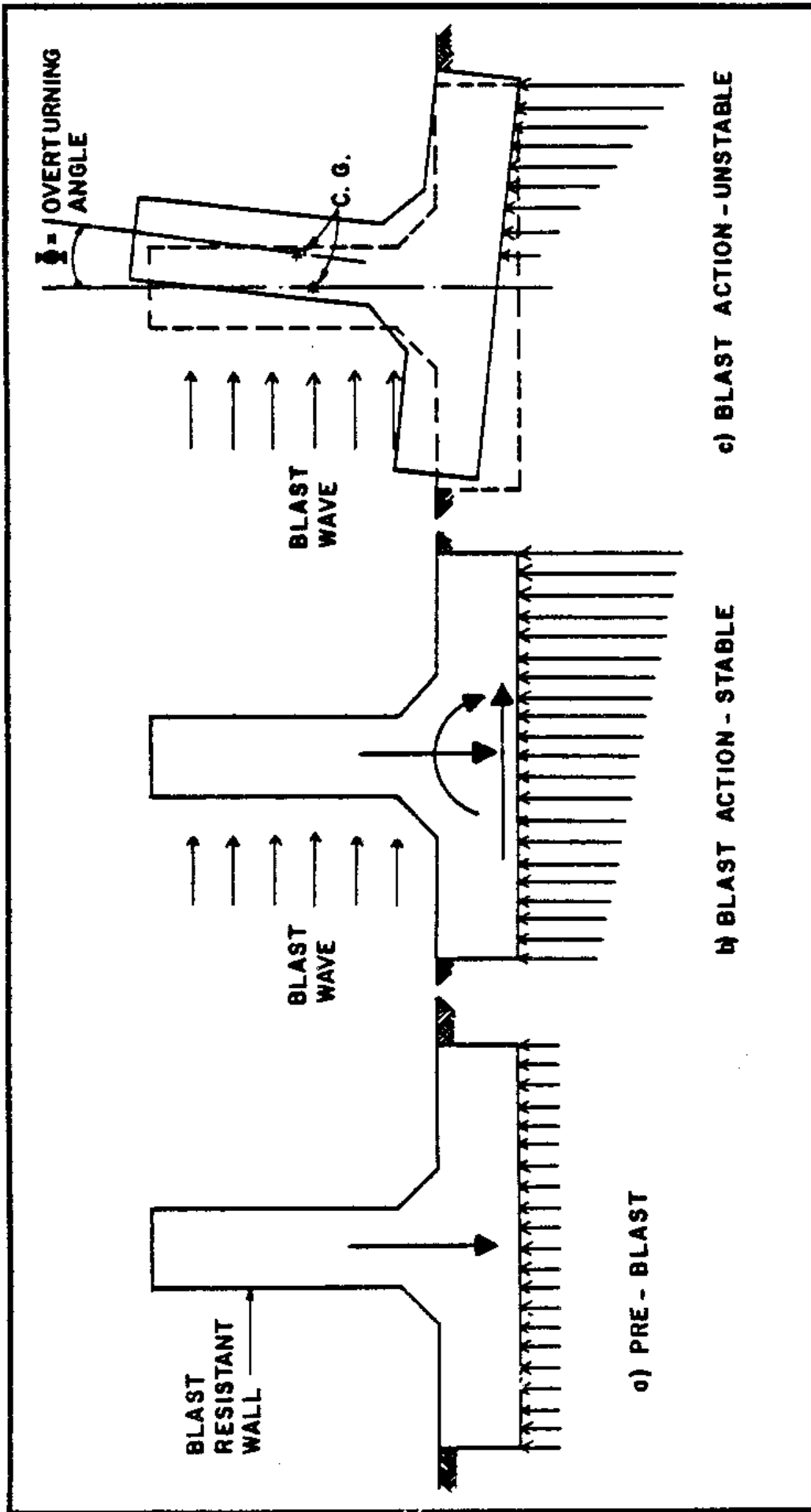

FIGURE 82

Changes in Distribution of Load on Foundation

(1) The design of a foundation subjected to dynamic loads, however, is a trial-and-error procedure. The initial size of the foundation is estimated, considering such factors as the forces acting on the structure and the static bearing stresses in the soil. The trial design is then analyzed to determine its response to the design dynamic loads.

(2) The types of foundations usually encountered in blast-resistant structures are shown in Figures 83, 84 and 85. As stated in the report by W. Stea titled *Overturning and Sliding Analysis of Reinforced Concrete Protective Structures*, the design of cantilever walls and single cell barriers (Figures 83 and 84) must consider the motion of the structures on the supporting soil. These structures rely completely on the soil to provide the required resistance to overturning and sliding motions. In the multi-cell barrier of Figure 80, the blast loads are resisted and confined by the blast-resistant walls, and the overall structure is restrained from overturning by the massive walls and foundation slab. Here, the motion of structure is not critical and is, therefore, not considered in the design.

(3) The main emphasis of this section is upon the design of foundations for protective structures susceptible to overturning, but the method of analysis and criteria is generally applicable to other structures encountered in blast resistant design.

b. Preliminary Design. In the design of the structures shown in Figures 83 and 84, the sizes of the blast-resistant walls are determined by the procedures and criteria outlined in NAVFAC P-397. In the design of the foundations, however, the following guidelines, as presented in Stea's report, should help in estimating the required size of the foundation:

(1) Cantilever wall barrier (Figure 86) usually requires a long foundation extension. The foundation thickness should be approximately 1.25 times the wall thickness and the length should be 45 percent of the height of the wall.

(a) The slope of the bottom face of the foundation should not exceed 5 degrees, since an increase in the slope reduces the moment arm of the resultant of the soil pressures about the center of gravity of the structure.

(b) Cantilever barrier foundations should be symmetric about the centerline of the blast-resistant wall.

(2) Single cell barriers (Figure 87) usually do not require long thick foundations to prevent overturning. The dimensions of the foundation are established by providing the foundation with sufficient bending strength to completely develop the ultimate strength of each blast wall. To achieve this, the distance between the compression and tension reinforcement, d_{rc} , should be equal to the maximum d_{rc} of the blast walls. The amount of concrete cover should conform to the ACI Code. The length of the foundation extension is established by providing the anchorage required for the reinforcing steel in the concrete.

With these estimated dimensions of the foundations, a dynamic analysis can now be performed. A computer program, OVER, written by Stea, et al., and described in Section 8, is suitable for such an analysis.

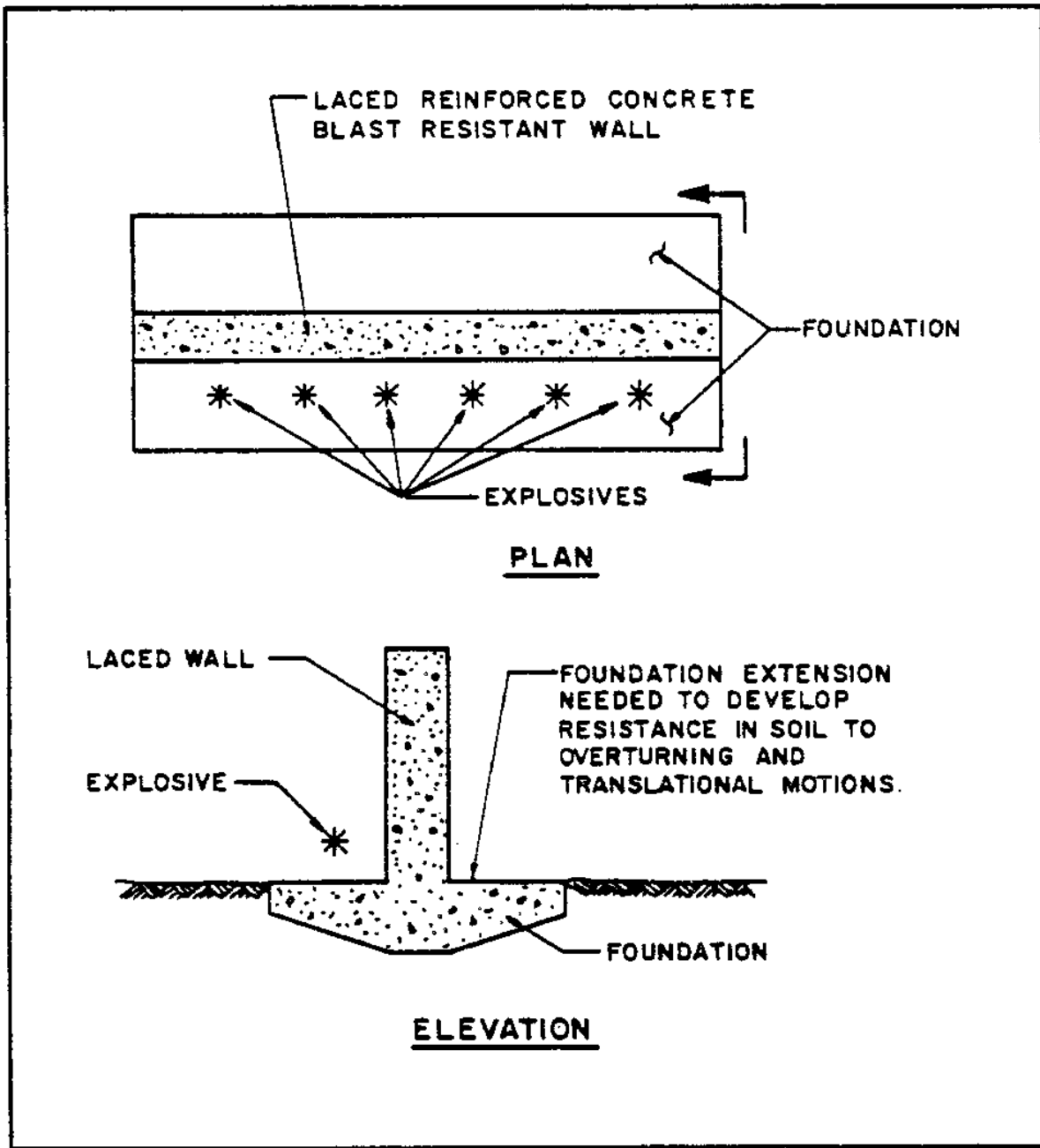

FIGURE 83
Cantilever Wall Barrier

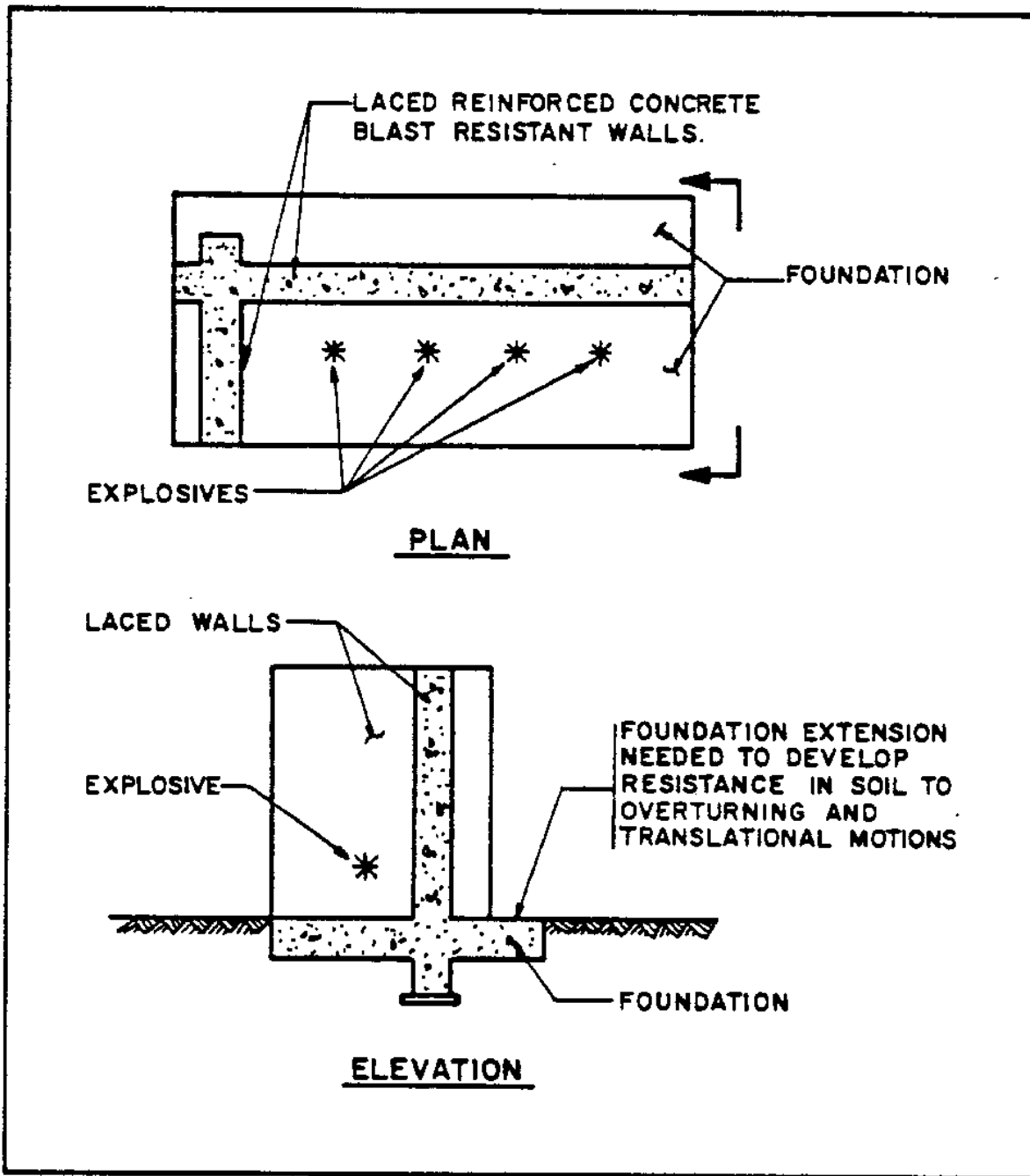

FIGURE 84
Two Wall Barrier

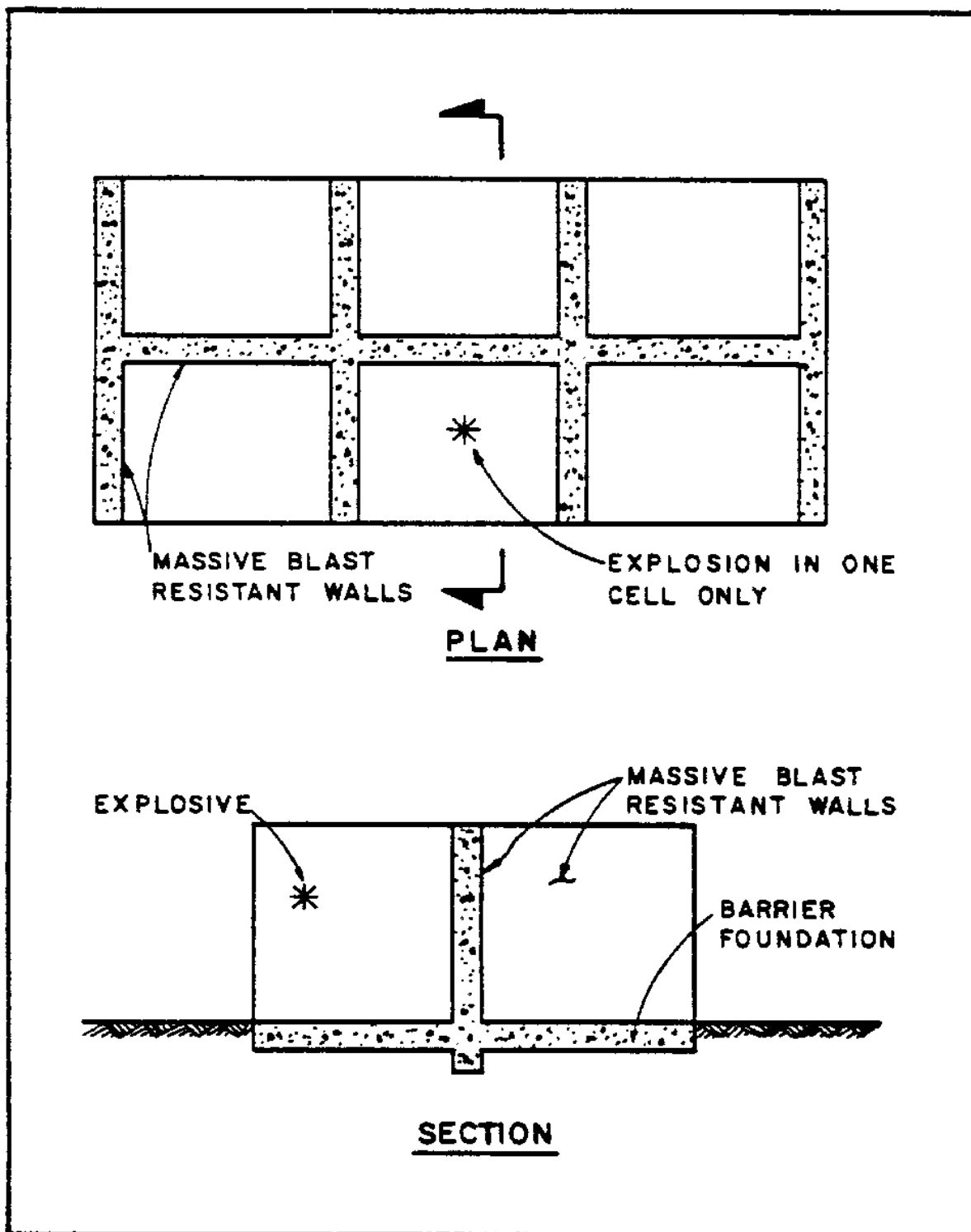

FIGURE 85
Multi - Cell Barricade

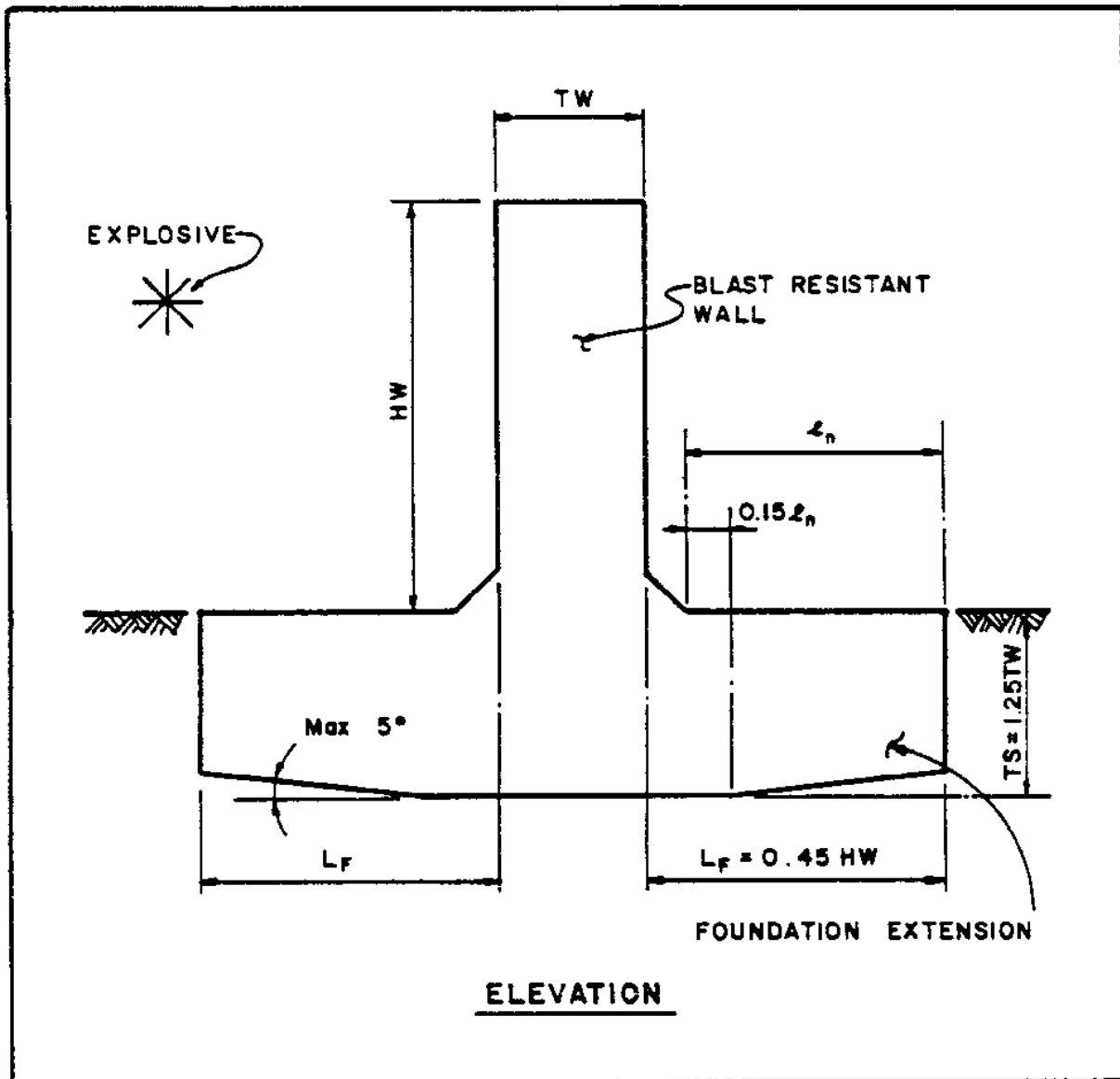

FIGURE 86

Cantilever Wall Barrier — Estimated Foundation Dimensions

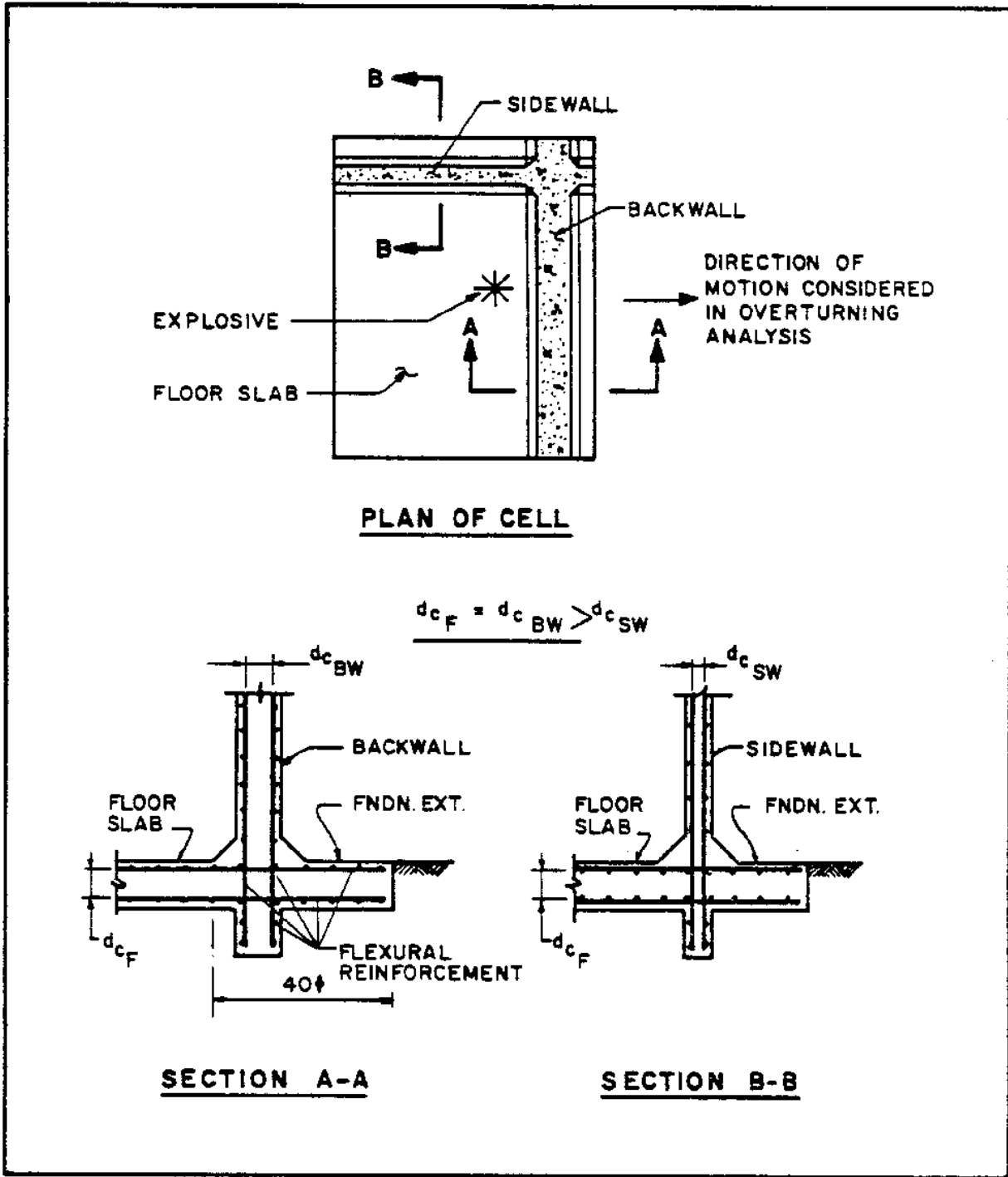

FIGURE 87
Single Cell Barrier – Estimated Foundation Dimensions

c. Design Criteria. The design criteria listed below are also presented in Stea's report for the two types of foundation extensions utilized in protective structures.

(1) Thick Foundation Extension, i.e., $*l_{fn}/d < 5$, where $*l_{fn}$ is the clear span of member to the face of the support and d is distance from extreme compression fiber to the centroid of tension reinforcement

(a) Allowable shear stress carried by the concrete is:

$$\text{EQUATIONS: } v_{rc} = [\phi] [3.5 - (2.5M_{rcr}) / (V_{ru}d)] \times [1.9(f'_{rc})^{1/2}] + 2,500p_{rw} (V_{ru}d / M_{rcr}) \quad (156a)$$

and:

$$[3.5 - (2.5M_{rcr}) / (V_{ru}d)] \leq 6(f'_{rc})^{1/2} \quad (156b)$$

where,

$[\phi]$ = capacity reduction factor = 0.85 for all sections
 v_{rc} = nominal permissible shear stress carried by concrete, psi
 M_{rcr} = applied design load moment at the critical section, in-lb
 V_{ru} = total applied design shear force at critical section, lb
 d = distance from extreme compression fiber to centroid of tension reinforcement, in
 f'_{rc} = specified compressive strength of concrete, psi
 p_{rw} = A_{rs} / bd , the ratio of area of flexural reinforcement to area of concrete within depth, d , and width, b .
 b = width of compression face, in

(b) The critical section for shear is taken as 15 percent of the clear span ($0.15 *l_{fn}$) measured from the face of the support.

(2) Thin Foundation Extension, i.e., $*l_{fn}/d > 5$.

(a) Allowable shear stress carried by concrete is expressed as:

$$\text{EQUATION: } v_{rc} = [\phi] [1.9(f'_{rc})^{1/2} + 2,500p_{rw}] < 2.28 [\phi] (f'_{rc})^{1/2} \quad (157)$$

Equation (157) is identical to Equation 5-10 of NAVFAC P-397. In fact, the provisions of Section 5-3 of NAVFAC P-397 are utilized to determine the permissible shear stress.

(b) The critical section for shear is taken at a distance, d , from the face of the support.

(3) Ultimate Resisting Moment.

(a) To resist the build-up of soil pressures beneath the structure, the ultimate unit resisting moment of the foundation extension should be computed as:

$$\text{EQUATION:} \quad M_{\Gamma u\gamma} = (A_{\Gamma s\gamma} f_{\Gamma s\gamma}) [d - (a/2)] / b \quad (158)$$

where,

$M_{\Gamma u\gamma}$ = ultimate unit resisting moment, in-lb/in
 $A_{\Gamma s\gamma}$ = area of tension reinforcement within the width b , in²
 $f_{\Gamma s\gamma}$ = static design stress for reinforcement, psi
 d = distance from extreme compression fiber to tension reinforcement, in
 a = $A_{\Gamma s\gamma} f_{\Gamma s\gamma} / 0.85 b f'_{\Gamma c\gamma}$, the depth of equivalent rectangular stress block, in
 $f'_{\Gamma c\gamma}$ = specified compressive strength of concrete, psi

(b) To develop the strength of a blast wall, the ultimate unit resisting moment of the foundation should be calculated using Equation (159):

$$\text{EQUATION:} \quad M_{\Gamma u\gamma} = A_{\Gamma s\gamma} f_{\Gamma ds\gamma} d_{\Gamma c\gamma} / b \quad (159)$$

where,

$f_{\Gamma ds\gamma}$ = dynamic design strength for the reinforcement (see Section 5-6 of NAVFAC P-397).
 $d_{\Gamma c\gamma}$ = distance between centroids of the compression and tension reinforcement, in.

(4) Minimum Flexural Reinforcement. The recommended minimum areas of flexural reinforcement are listed in Table 31. These insure the proper structural behavior of the foundation and also prevent excessive cracking and deformations under conventional loads.

TABLE 31
Minimum Area of Flexural Reinforcement

Reinforcement	One-way element	Two-way element
Main	$A_{\Gamma s\gamma} = 0.0025 bd$	$A_{\Gamma s\gamma} = 0.0025 bd$
Other	$A_{\Gamma s\gamma} = 0.0010 bT_{\Gamma c\gamma} [*]$	$A_{\Gamma s\gamma} = 0.0018 bd$

[*] $T_{\Gamma c\gamma}$ = total thickness of foundation

3. SOIL-STRUCTURE INTERACTION.

a. Introduction. For the dynamic analysis of the foundation, the properties of the underlying soil should be estimated as accurately as possible, since they have a large impact on the design. The non-linear behavior of soils subjected to dynamic loads is simulated by one-way springs. Equations for determining the equivalent spring constants for the soil in both the vertical and horizontal directions are presented by Whitman in Design Procedures for Dynamically Loaded Foundations, and the procedures are adequately described in Stea's report. However, in the absence of more reliable data which would be achieved through field tests and other rigorous analyses), the values in Tables 32 and 33 should be used as estimates of the soil properties. Note that these soil properties are correlated with the results of a minimum of shallow test borings together with a visual description of the soil encountered and the blow count for standard penetrations tests.

b. Overturning Design Criteria as Related to Soils Data. The properties of the soil grossly affect the response of the structure. Therefore, these properties have a large impact on the foundation design. Tables 32 and 33 provide for a particular soil, the properties in the soft or loose condition, and the compact or hard condition. The actual condition of the soil at a given site will be somewhere between these extremes.

(1) In order to account for the most severe design conditions for both overturning and strength, the structure is analyzed for both conditions of the soil. The response of the structure on the soft condition of the soil establishes the length of the foundation extension required to prevent overturning, whereas the response of the compact condition of the soil dictates the thickness of concrete and amount of reinforcing steel required for the foundation extension to resist the bearing pressures developed in the soil beneath the structure.

(2) Generally, rotations of the structures that approach the point of incipient overturning (as defined in Figure 88) can be tolerated. Therefore, for the design to be efficient, the peak response of the structure on the soft soil should approach incipient overturning. To insure that the structure will not overturn on the soft soil, the peak rotation of the structure on the compact soil is limited to a percentage of the overturning angle (defined in Figure 89). The results of several design studies indicate that limiting the peak rotation of the structure on the compact soil to a value of approximately 40 percent of the overturning angle will insure that the structure will not overturn, but will approach a peak response of incipient overturning on the soft soil.

(3) The guidelines presented in the previous paragraph are utilized in the design of the foundation extension by performing a series of overturning analyses. After each analysis, the dimensions of the foundation extension are modified, according to the analysis results. This process is repeated until the results of the analyses for both soil conditions indicate that the structure rotates to 40 percent of its overturning angle on the compact soil and does not overturn on the soft soil. This procedure is generally applicable to cantilever wall barriers only. However, it can be applied to single cell barriers provided it does not alter the foundation dimensions to the extent that the following minima are not maintained:

TABLE 32
Soil Properties - Non-Cohesive Soils

Soil Type	Description	"N"	Modulus of elasticity (psi)	Poisson's ratio n[*]	Friction factor f' [C]	
Granular	Silt	Loose	4	1,000	0.40	0.4
		Very Compact	30	2,000	0.30	0.8
	Sand	Loose	10	1,800	0.30	0.5
		Very Compact	50	7,000	0.25	0.7
	Gravel	Loose	15	3,000	0.20	0.6
		Very Compact	70	20,000	0.15	0.7
Bedrock			20,000- 50,000	0.10	0.7	

[*]For soils below the water table, n = 0.50

TABLE 33
Soil Properties - Cohesive Soils

Description	Plasticity index	Condition	"N"	Modulus of elasticity (psi)	Poisson's ratio n[*]	Ad (p)
Slightly Plastic	1 - 10	Medium soft	5	2,000	0.45	
		Hard	20	5,000	0.45	
Plastic	10 - 20	Medium soft	4	2,000	0.45	
		Hard	15	6,000	0.45	
Very Plastic	20+	Medium soft	3	2,000	0.45	
		Hard	12	6,000	0.45	

[*]For soils below the water table, n = 0.50

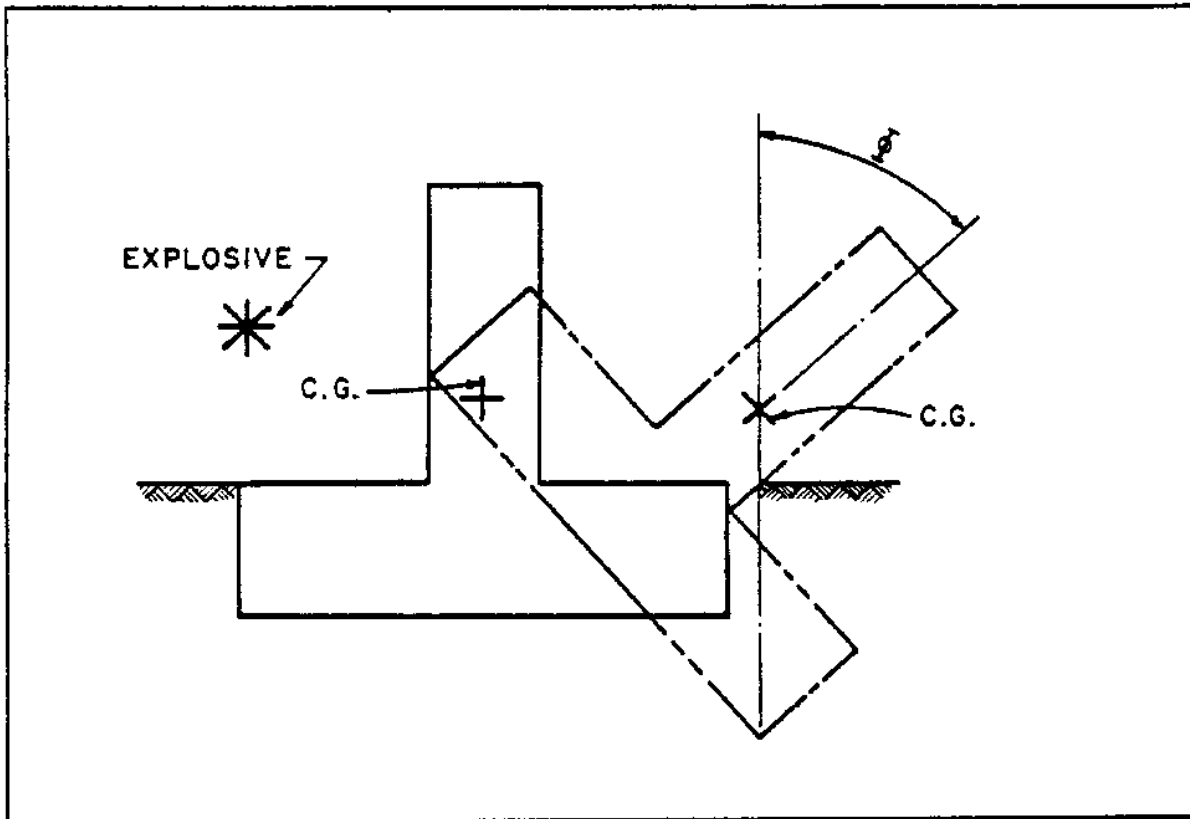

FIGURE 88
Displaced Configuration of Structure at Incipient Overturning

2.08-309

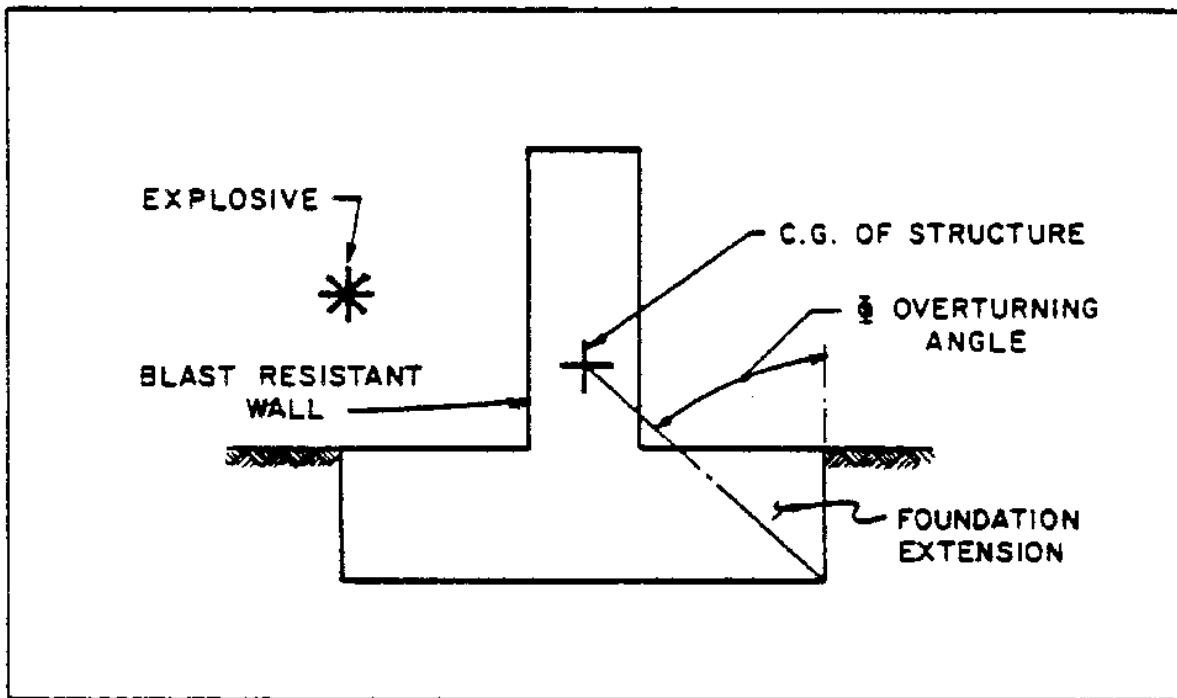

FIGURE 89
Definition of Overturning Angle

2.08-310

1. The minimum length of the foundation extension required for anchorage of the reinforcement in the concrete; or

2. The minimum required plan size to transfer the conventional (dead and live) working loads to the supporting soil without exceeding the allowable bearing pressure for the soil.

In the event that piles are utilized, Item 2. above can be ignored.

(4) The criteria presented in this section and the data prepared in Tables 32 and 33 are intended to be used where more reliable soil data is not available. If more reliable data is available, the structure should be analyzed for the specific properties derived from the data. In this situation, the structure can be permitted to rotate to the point of incipient overturning under the action of the blast.

4. EXAMPLE PROBLEM - Design of Simple Type Foundation Extension.

Problem: Design a foundation extension for a cantilever wall barrier. Determine the length, thickness, and amount of reinforcing steel required for the foundation extension.

Given:

- (1) Configuration of the structure and details of the wall which is designed to the incipient failure condition.
- (2) Quantity of explosive and location relative to structure.
- (3) Soil data.
- (4) Design strength for building materials.

Solution:

(1) Based on the configuration of the structure and the guidelines of Section C.2.2 of Stea's report, estimate the dimensions of the foundation extension to be utilized in the overturning analysis. For single cell barrier(s) supported by buttress walls, determine the area of reinforcement required for the foundation to develop the strength of the backwall and sidewall of the structure.

(2) Determine the soil bearing pressures beneath the foundation (using the foundation dimensions estimated in Step 1) for the working (dead and live) load condition.

The foundation must have sufficient plan size to transfer the dead and live loads to the supporting soil without exceeding the allowable bearing pressure for the soil. If the allowable bearing pressure is exceeded, the length and, where feasible, the width of the foundation should be increased in order to provide the plan size required. If an excessively large plan size is required, piles should be used. In any event, the plan size should not be decreased unless the results of the subsequent overturning analysis indicate otherwise.

(3) Apply a 20 percent safety factor to the charge weights and determine the average unit impulse loads on the foundation slab within the cell. To determine the loads on the foundations of cantilever wall barriers, utilize the procedures of NAVFAC P-397 or the computer program by S. Levy in the report, An Improved Computer Program to Calculate the Average Blast Impulse Loads Acting on a Wall of a Cubicle.

(4) Correlate the available test and descriptive data for the soil at the construction site with the data of Tables 32 and 33, and establish the range of critical soil properties to be utilized in the analysis. The structure is analyzed for both the soft and compact conditions (specified in the tables) of the actual soil. In the event that more accurate data is available, only the actual soil condition need be considered in the analysis.

(5) Prepare the input data for Computer Program OVER according to the instructions of Section 5 of Stea's report.

(6) Run the analysis utilizing the overturning analysis computer program.

(7) Inspect the results of both analyses and determine for each:

- a) If the structure reached its peak response. If not, rerun the analysis utilizing more integration time steps.
- b) If the structure overturned. If so, it was probably due to the soft condition of the soil. If overturning occurs, the length of the foundation extension will have to be increased and both analyses rerun.
- c) If the structure experienced excessive horizontal (sliding) displacements under the action of the blast. Horizontal displacements become a factor when explosives are stored nearby. In this situation, there is danger of the structure sliding into the explosives and detonating them, thereby propagating the explosion. Generally, large sliding motions will occur on the cohesive (clay) soils. This condition is remedied by adding mass to the structure foundation in order to increase the friction forces between the structure and the soil. The added mass will also lower the center of gravity of the structure which causes the toe of the foundation to penetrate further into the soil, thereby decreasing the sliding motions. However, this will increase the rotations of the structure and therefore the foundation extension may have to be lengthened, depending on the results of the previous analysis. The revised structure is always reanalyzed for both conditions of the soil.

Further evaluation of the results is deferred until both analyses indicate that the structure attained its peak response and will neither overturn nor translate large distances under the action of the blast.

(8) Once the conditions of Step 7 are satisfied, evaluate the results of the analysis in order to determine if any further modification of the foundation dimensions is required. These added modifications are required when the analysis indicates that the structure attains peak rotations which are far less than what is permitted. In most cases, analyses of the structure supported by both a soft and a compact soil are required and generally, the foundation extension can be shortened until the results of the analyses indicate that the structure rotates to 40 percent of its overturning angle on the compact soil, provided the decreased length of the foundation extension does not violate the design criteria in paragraph 3.b of this section.

In the event that more accurate soils data is available, the structure can be allowed to rotate to the point of incipient overturning (see Figures 88 and 89).

(9) A detailed design of the foundation extension can commence after satisfactory results have been obtained from the computer analysis.

Determine the location of the critical section for shear according to the provisions of paragraph 2.c of this section.

(10) Determine from the printout of the soil bearing pressure-time history, the peak shear (and corresponding bending moment for thick sections, $*l_{cr}/d < 5$) at the critical section for shear and the peak bending moment at the face of the support. These quantities (V_{cr} , M_{cr} and M_{cr}) are computed by the program for a cantilever wall barrier. For other structural configurations, these quantities must be computed manually.

Generally, the bearing pressure distributions at several time stations are investigated to determine the peak shear and bending moments. When the computation is performed by the computer program, the bearing pressure distribution at every integration time station is investigated.

The peak shear usually occurs when the point on the foundation with zero bearing pressure approaches the critical section for shear on the extension. Figure 90 shows the configuration of the bearing pressure distribution curve, and identifies the design parameters and critical sections for shear and bending. The figure also illustrates the order in which the bearing pressures are printed out by the computer program.

Figure 91 shows the free body diagrams for computing the peak shear and bending moment on the foundation extension. The shear is determined by computing the area within the bearing pressure distribution curve. The bending moment is determined by computing the moment of the area within the bearing pressure distribution curve about the desired location on the extension.

(11) Determine the allowable shear stress that can be carried by the concrete using the equations provided in paragraph 2.c. of this section.

(12) Determine the thickness of concrete, d , required to carry the peak applied shear load using Equation (160).

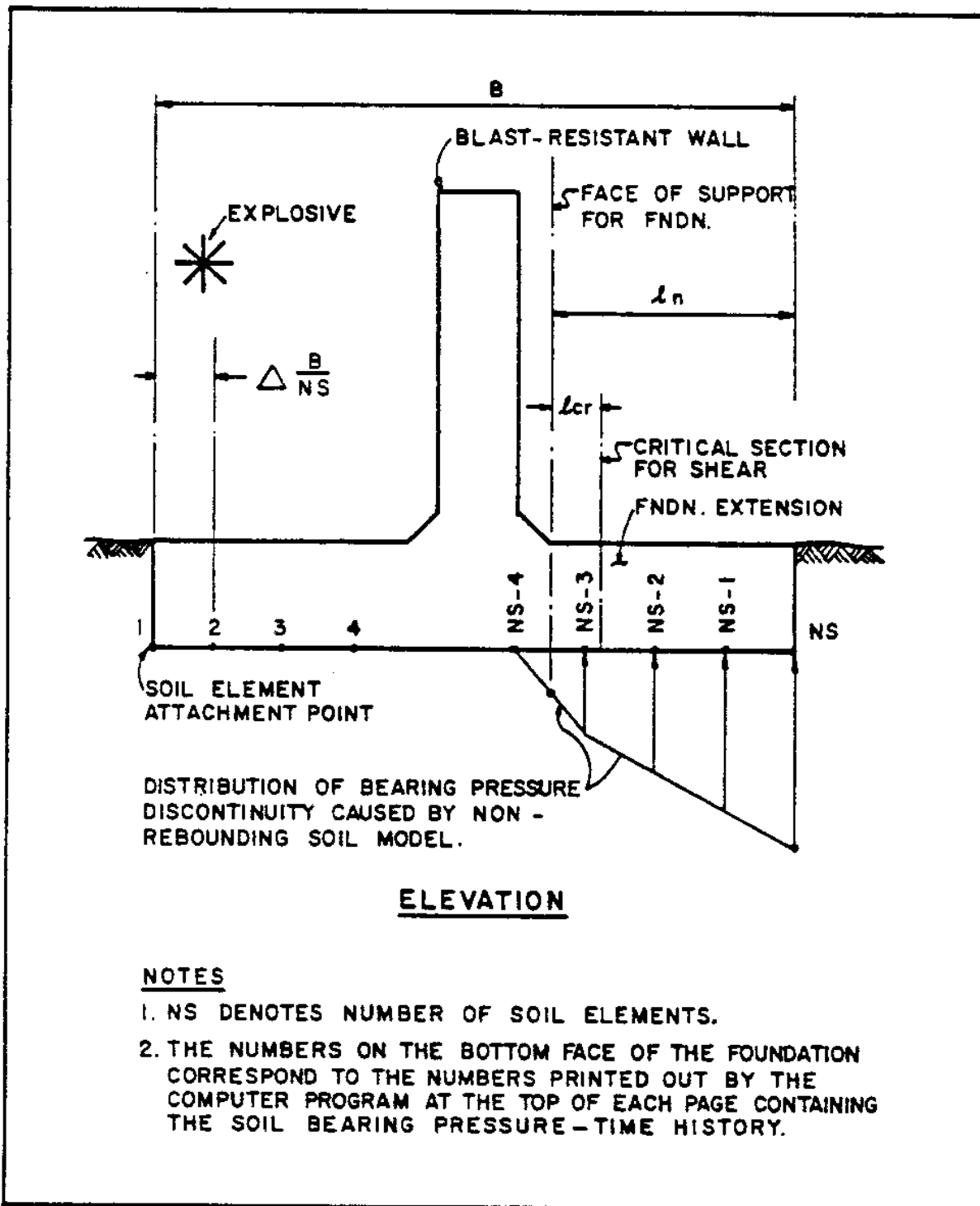
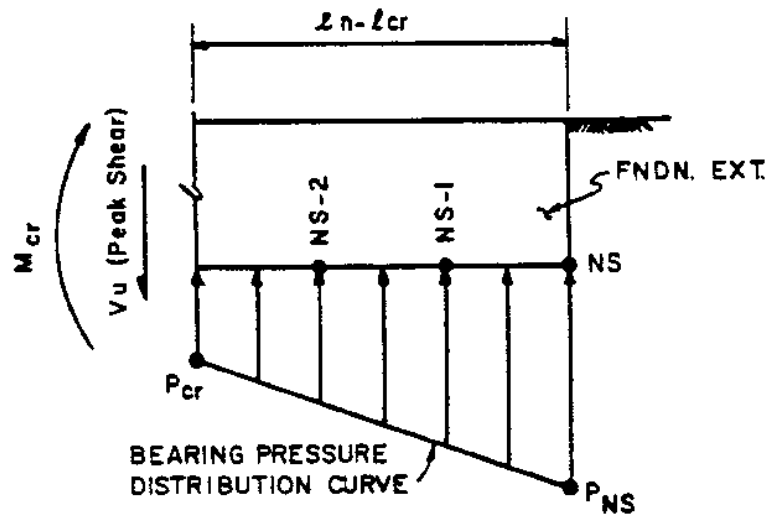
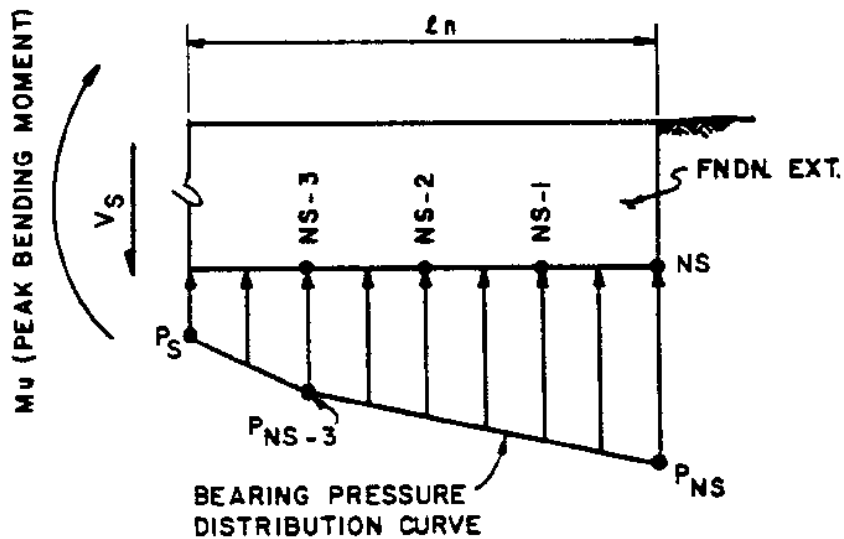

FIGURE 90

Design Parameters - Simple Type Foundation



FREE BODY DIAGRAM FOR SHEAR COMPUTATION



FREE BODY DIAGRAM FOR BENDING MOMENT COMPUTATION

FIGURE 91

Free Body Diagrams of Simple Type Foundation Extension for Computation of Peak Shear and Bending Moment

EQUATION:
$$d = V_{\Gamma u \Gamma} / v_{\Gamma c \Gamma} \quad (160)$$

where,

d = distance from extreme compression fiber to tension steel, in
 $V_{\Gamma u \Gamma}$ = peak applied shear load, lb/in
 $v_{\Gamma c \Gamma}$ = permissible shear stress carried by concrete, psi

(13) Determine the area of the flexural (main) reinforcement required using the peak applied bending moment (at the face of the support) in Equation (158). At the same time, compute the main reinforcement, according to the provisions of Table 31.

(14) Determine the actual thickness of the foundation using the following equation:

EQUATION:
$$T_{\Gamma c \Gamma} = d + d_{\Gamma b \Gamma} / 2 + c \quad (161)$$

where,

$T_{\Gamma c \Gamma}$ = thickness of foundation, in
 d = distance from extreme compression fiber to centroid of tension reinforcement, in
 $d_{\Gamma b \Gamma}$ = diameter of tension reinforcement bar, in
 c = thickness of bottom concrete cover specified in Section 7.14 of the ACI Code (always 3 inches).

Depending on the configuration of the structure, a significant decrease in the foundation thickness could result in a substantial increase in the peak rotation of the structure. This is generally the case with cantilever wall barriers; therefore, if the foundation thickness computed is much less than the thickness used in the overturning analysis, repeat the analysis with the revised foundation thickness in order to verify the final design. The verification analysis is generally not required for single cell barriers.

Calculation:

Given:

- (1) Configuration of the structure and details of the wall which is designed to the incipient failure conditions (Figure 92).
- (2) Quantity of explosive: three charges of TNT each weighing 1,900 lb and located as shown in Figure 92.

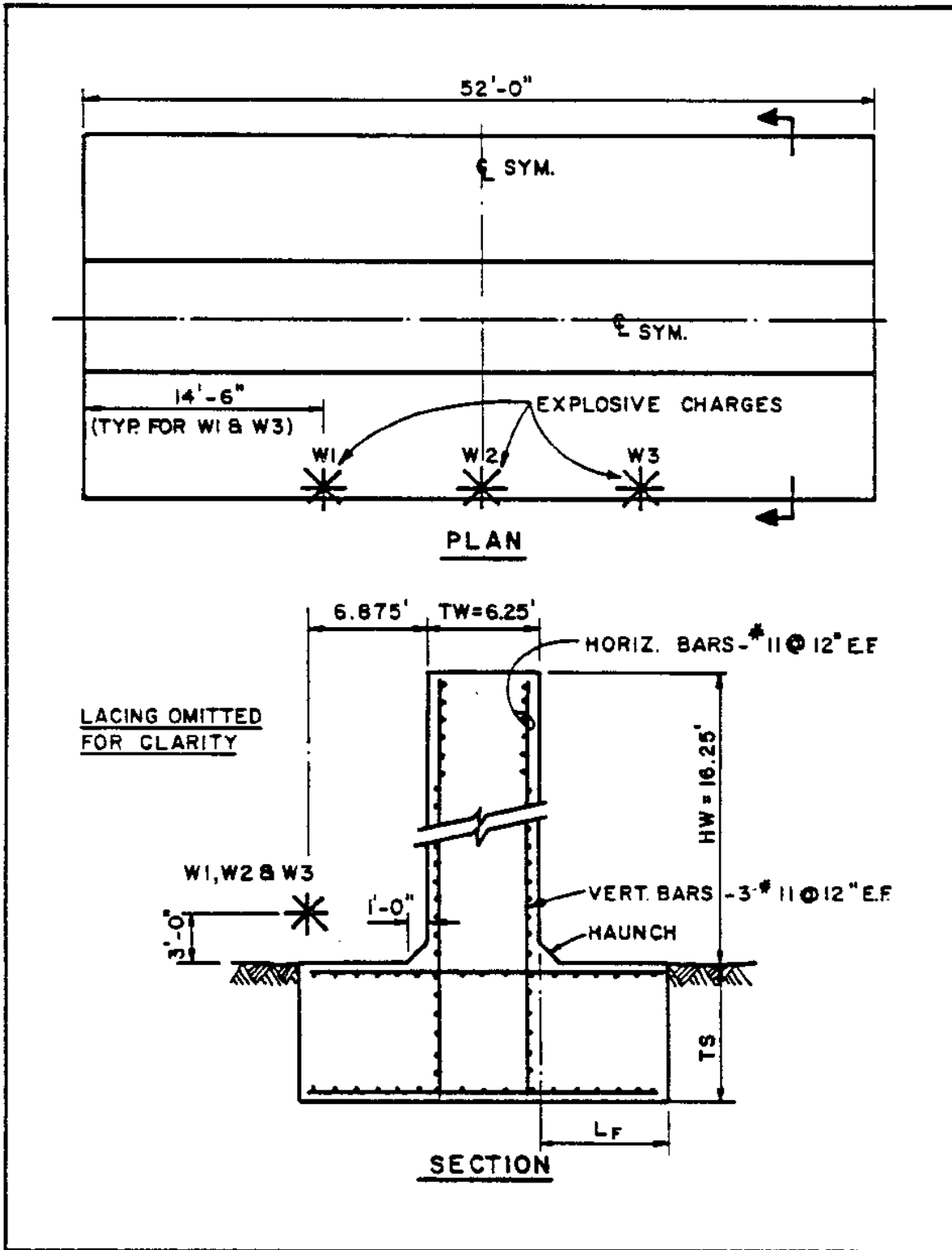

FIGURE 92

Dimensions of Structure, Design Details of Backwall and Charge Locations

(3) Soil data available:

Description - Gravel

Compaction - Medium

Blow count - 40

Allowable bearing pressure - 5 tons/ft²

(4) Design strength for building materials:

Concrete, $f'_c = 4,000$ psi

Steel, $f_y = 60,000$ psi

Solution:

(1) Estimate the dimensions of the foundation extension to be used in the overturning analysis.

Thickness of wall: (TW) = 6.25 ft

Height of wall: (HW) = 16.25 ft

Estimated thickness of foundation extension:

$$\begin{aligned} TS &= 1.25(TW) \\ &= 1.25(6.25) \\ &= 7.81 \text{ ft} \end{aligned}$$

Use 7.83 ft = 7 feet 10 inches

Estimated length of foundation extension:

$$\begin{aligned} L_F &= 0.45(HW) \\ &= 0.45(16.25) \\ &= 7.31 \text{ ft} \end{aligned}$$

Use 7.5 ft = 7 feet 6 inches

For an efficient design, the foundation should be symmetrical about the centerline of the wall.

(2) Determine the soil bearing pressure for the weight of the structure.

Estimate weight of structure:

$$\begin{aligned} W_s &= \frac{16.25(6.25) + [2(7.5) + 6.25](7.83)(150)}{2,000} \\ &= 1,045 \text{ T} \end{aligned}$$

Surface area of foundation:

$$\begin{aligned} A &= 52[2(7.5) + 6.25] \\ &= 1,105 \text{ ft}^2 \end{aligned}$$

Allowable bearing pressure:

$$\begin{aligned} W_{rs}/A &= 1,045/1,105 \\ &= 0.95T/\text{ft}^2 < 5T/\text{ft}^2 \end{aligned}$$

The foundation is adequate for the dead and live load condition.

- (3) Determine the average impulse loads on the foundation slab.

$$\begin{aligned} \text{Design charge weight} &= 1.20 (W) \\ &= 1.20(1,900) \\ &= 2,280 \text{ lb.} \end{aligned}$$

Using the procedure and data provided in NAVFAC P-397, the following average impulse loads on the foundation slab are computed:

$$\begin{aligned} W_{r1}: \bar{i}_{rb} &= 4,400 \text{ psi-ms} \\ W_{r2}: \bar{i}_{rb} &= 4,800 \text{ psi-ms} \\ W_{r3}: \bar{i}_{rb} &= 4,400 \text{ psi-ms} \end{aligned}$$

- (4) Establish the range of critical soil properties to be utilized in the analyses.

The field description of the soil and the results of the penetration tests indicate that the soil is a medium compact gravel; therefore, the structure is analyzed for the properties of the loose and very compact gravels provided in Table 32. The properties utilized in the analyses are presented below:

	Loose	Very Compact
	_____	_____
Modulus of elasticity (psi)	3,000	20,000
Poisson's Ratio	0.2	0.15
Friction Factor	0.6	0.70

- (5) Prepare the input data decks for the computer program.

Since the structure is a cantilever barrier, the "Normal Option" mode of the computer program is utilized to analyze the structure.

- (6) Run the analysis on the CDC 6600 computer using the overturning analysis program.

- (7) Inspect the results of the analyses.

The following is a summary of the peak response parameters for the structure on both the loose and very compact gravel.

Loose Gravel:

Maximum rotation of structure = 36.2deg.
 Maximum horizontal displacement of foundation =
 10.0 in
 Ratio of maximum rotation to overturning angle =
 0.70

Very Compact Gravel:

Maximum rotation of structure = 20.1deg.
 Maximum horizontal displacement of foundation =
 3.80 in
 Ratio of maximum rotation to overturning angle =
 0.39

Inspection of the above tabulation of the results indicates that, in both analyses, the structure:

- (a) Has reached its peak response
- (b) Did not overturn
- (c) Did not experience excessive horizontal (sliding) displacements.

Therefore, the design proceeds to the next step.

- (8) Inspection of the results (peak rotations) summarized in Step 7 indicates that no further modifications of the foundation dimensions for overturning or sliding are required; therefore, the design can proceed to the next step.

- (9) Determine the location of the critical section for shear.

$$\begin{aligned} *l_{rn} &= 6.50 \text{ ft or } 78.0 \text{ in} \\ TS &= 7.81 \text{ ft or } 94.0 \text{ in} \end{aligned}$$

Assume 4 inches for the bottom cover and tension reinforcement:

$$\begin{aligned} d &= 94.0 - 4.0 \\ &= 90.0 \text{ in} \end{aligned}$$

$$\begin{aligned} *l_{rn}/d &= 78.0/90.0 \\ &= 0.87 < 5.0 \end{aligned}$$

According to the provisions of paragraph 2.c. of this section, the foundation is considered a thick section and the critical section for shear is $0.15 *l_{rn}$ from the face of the support:

$$\begin{aligned} *l_{cr} &= 0.15 *l_{rn} \\ &= 0.15(78) \\ &= 11.7 \text{ inches from the haunch (see Figure 93)} \end{aligned}$$

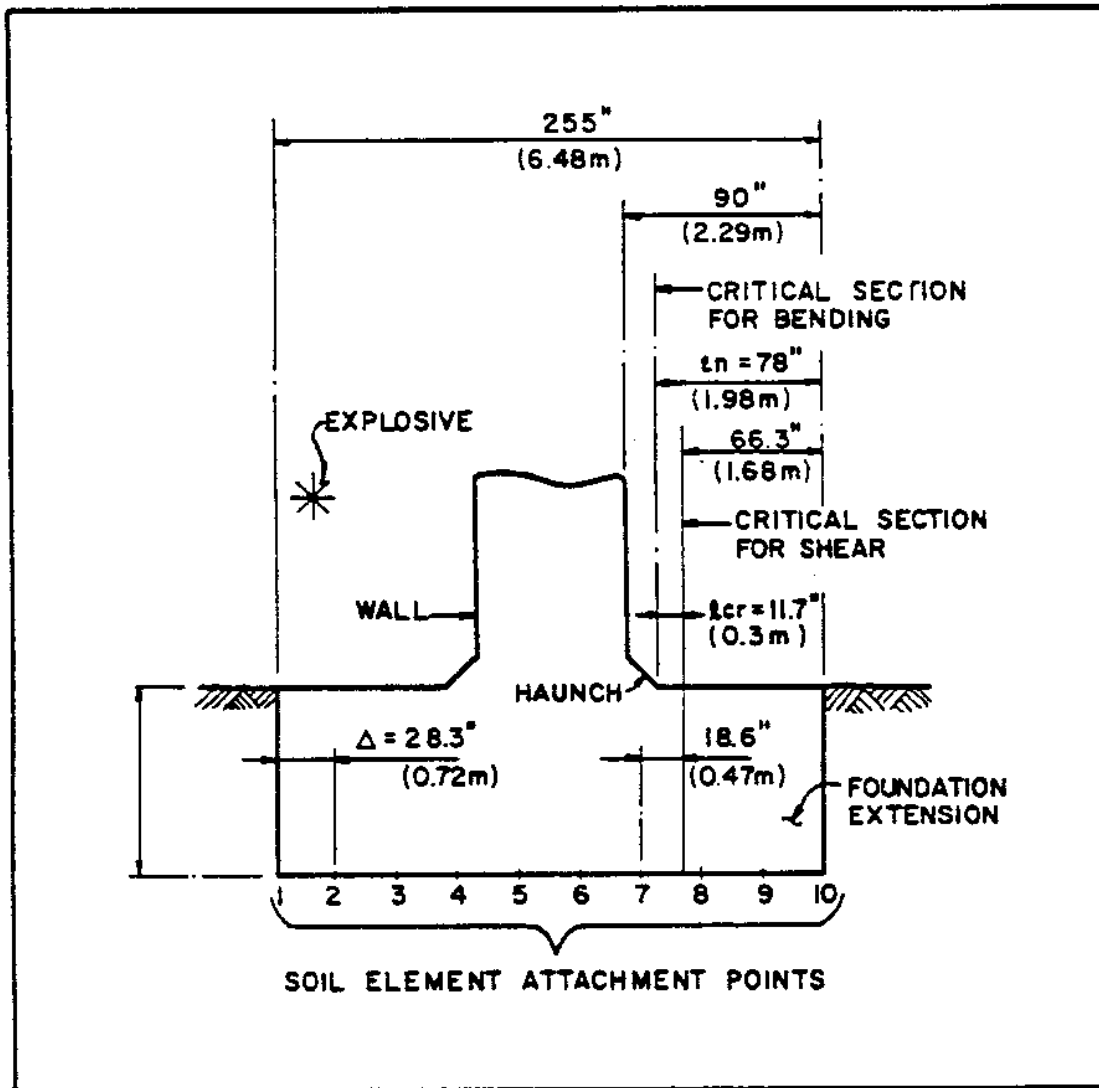

FIGURE 93

Locations of Critical Sections of Foundation Extension for Shear and Bending

- (10) Determine the peak shear (and the corresponding bending moment) at the critical section for shear and the peak bending moment at the face of the support. These quantities are computed for the response of the structure on the compact gravel. (Although these quantities are computed by the program, the hand calculation is presented to illustrate the procedure.)

The soil bearing pressures at three time stations are investigated. Figure 93 shows the location of the critical sections for shear and bending on the foundation extension. The locations of the soil element attachment points are also shown in the figure. The pressure distribution for which the shears and bending moments are computed are shown in Figure 94. The shears and bending moment are computed for a 1-inch wide segment of the foundation extension.

At $t = 0.0428$ second:

$$P_{cr} = \frac{(479.5 - 233.6)46.9 + 233.6}{4(28.3)}$$

$$= 335.5 \text{ psi}$$

$$P_{s} = \frac{(479.5 - 233.6)35.2 + 233.6}{4(28.3)}$$

$$= 310.1 \text{ psi}$$

$$V_{u} = \frac{(335.5 + 479.5)66.3}{2}$$

$$= 27,017 \text{ lb/in}$$

$$M_{u} = \frac{310.1(78)^2}{2} + \frac{(479.5 - 310.1)(78)^2}{3}$$

$$= 1,286,867 \text{ in-lb/in}$$

At $t = 0.05356$ second:

$$P_{cr} = \frac{(549.7 - 311.4)18.6 + 311.4}{3(28.3)}$$

$$= 363.6 \text{ psi}$$

$$P_{s} = \frac{(549.7 - 311.4)6.9 + 311.4}{3(28.3)}$$

$$= 330.6 \text{ psi}$$

$$V_{u} = \frac{(363.6 + 549.7)66.3}{2}$$

$$= 30,276 \text{ lb/in}$$

$$M_{u} = \frac{330.6(78)^2}{2} + \frac{(549.7 - 330.6)(78)^2}{3}$$

$$= 1,450,020 \text{ in-lb/in}$$

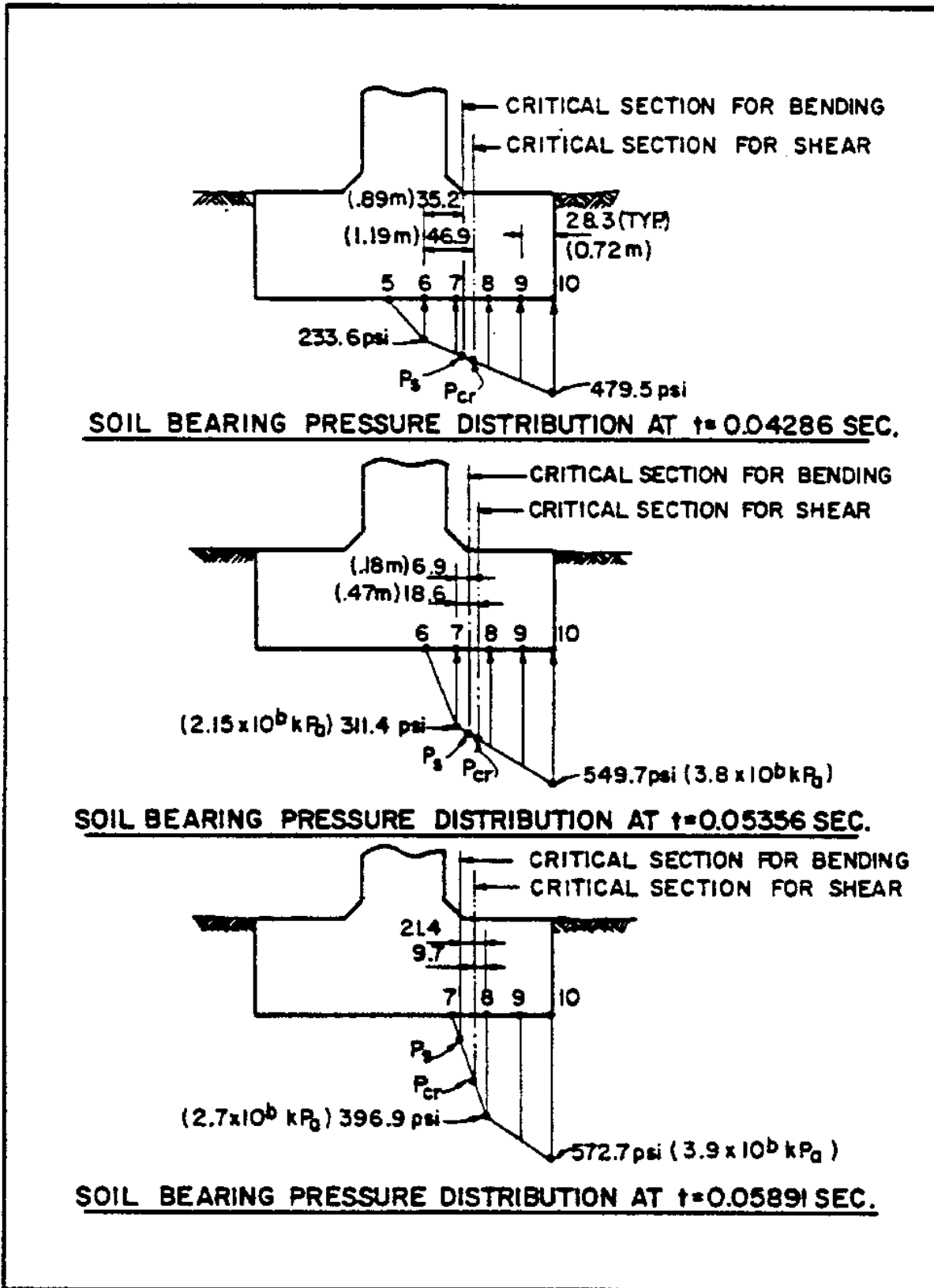

FIGURE 94
Foundation Extension Design Loadings

At $t = 0.05891$ second:

$$P_{cr\gamma} = (18.6/28.3)396.9 \\ = 260.9 \text{ psi}$$

$$P_{s\gamma} = (6.9/28.3)396.9 \\ = 96.8 \text{ psi}$$

$$V_{u\gamma} = \frac{(572.7 + 396.9)(2)28.3 + (396.9 + 260.9)9.7}{2} \\ = 30,630 \text{ lb/in}$$

$$M_{u\gamma} = \frac{96.8(21.4)^2}{2} + \frac{(396.9 - 96.8)(21.4)^2}{3} \\ + 396.9[2(28.3)][2(28.3)/2 + 21.4] \\ + (572.7 - 396.9)28.3[4(28.3)/3 + 21.4] \\ = 1,478,660 \text{ in-lb/in}^2$$

The peak shear occurs at $t = 0.05891$ second.

The corresponding bending moment at the critical section for shear is computed as follows:

$$M_{cr\gamma} = \frac{260.9(9.7)^2}{2} + \frac{(396.9 - 260.9)9.7^2}{3} \\ + 396.9[2(28.3)][2(28.3)/2 + 9.7] \\ + (572.7 - 396.9)28.3[4(28.3)/3 + 9.7] \\ = 1,106,179 \text{ in-lb/in}$$

The peak shear and corresponding bending moment at the critical section for shear are:

$$V_{u\gamma} = 30,630 \text{ lb/in} \\ M_{cr\gamma} = 1,106,179 \text{ in-lb/in}$$

The peak moment at the face of the support is:

$$M_{u\gamma} = 1,478,660 \text{ in-lb/in}$$

- (11) Determine the allowable shear stress for the concrete.

Since $*l_{r\gamma}/d < 5$, the allowable shear is computed using Equation (156a):

$$V_{u\gamma} = 30,630 \text{ lb/in} \\ M_{cr\gamma} = 1,106,179 \text{ in-lb/in} \\ d = 90 \text{ inches} \\ f'_{c\gamma} = 4,000 \text{ psi} \\ pw = 0.0025, \text{ assume minimum from Table 28} \\ v_{c\gamma} = 0.85[3.5 - 2.5(1,106,179)/(30,630(90))]$$

$$\times [1.9(4,000) L_{1/2} + 2,500(0.0025)(30,630)]$$

$$\times 90/1,106,179] \\ = 0.85(2.5)(135.7)$$

- (12) Determine the thickness of concrete required to carry the shear.

$$\begin{aligned}V_{\Gamma U\gamma} &= 30,630 \text{ lb/in} \\v_{\Gamma C\gamma} &= 288.5 \text{ psi} \\d &= 30,630/288.5 = 106.2 \text{ in}\end{aligned}$$

- (13) Determine the amount of flexural reinforcement required.

Main reinforcement:

Assume "a" block = 6 inches

$$A_{\Gamma S\gamma} = M_{\Gamma U\gamma} b / f_{\Gamma S\gamma} (d - a/2)$$

$$M_{\Gamma U\gamma} = 1,478,660 \text{ in-lb/in}$$

$$b = 12 \text{ in}$$

$$d = 106.2 \text{ in}$$

a = assumed value of 6 in

$$f_{\Gamma S\gamma} = 60,000 \text{ psi}$$

$$\begin{aligned}A_{\Gamma S\gamma} &= 1,478,660(12)/60,000(106.2 - 6/2) \\&= 2.87 \text{ in}^2/\text{ft}\end{aligned}$$

$$a = A_{\Gamma S\gamma} f_{\Gamma S\gamma} / 0.85bf'$$

$$f'_{\Gamma C\gamma} = 4,000 \text{ psi}$$

$$\begin{aligned}a &= 2.87(60,000)/0.85(12)(4,000) \\&= 4.22 \text{ in}\end{aligned}$$

$$\begin{aligned}A_{\Gamma S\gamma} &= 1,478,660(12)/60,000(106.2 - 4.22/2) \\&= 2.84 \text{ in}^2/\text{ft}\end{aligned}$$

$$\begin{aligned}A_{\Gamma \min\gamma} &= 0.0025bd = 0.0025(12)(106.2) \\&= 3.19 \text{ in}^2/\text{ft}\end{aligned}$$

Use minimum steel: $A_{\Gamma S\gamma} = 3.19 \text{ in}^2/\text{ft}$

Area of No. 11 bar = 1.56 in^2

Use two No. 11 bars, top and bottom, at 12-inch spacing. These bars should extend from one end of the foundation to the other end (see Figure 91).

Reinforcement in other direction:

$$\begin{aligned}A_{\Gamma S\gamma} &= 0.001bT_{\Gamma C\gamma} \\T_{\Gamma C\gamma} &= 110 \text{ inches} \\A_{\Gamma S\gamma} &= 0.001(12)(110) \\&= 1.32 \text{ in}^2/\text{ft}\end{aligned}$$

Use one No. 10 bar, top and bottom, at 12-inch spacing. These bars should be placed in both extensions of the foundation (see Figure 91).

(14) Determine the actual thickness of the foundation.

$$\begin{aligned}d &= 106.2 \text{ inches} \\d_{rb} &= 1.41 \text{ inches} \\c &= 3.0 \text{ inches} \\T_{rc} &= 106.2 + 1.41/2 + 3.0 \\&= 109.9 \text{ inches}\end{aligned}$$

Use $T_{rc} = 110$ inches.

5. NOTATION.

a	-	Depth of equivalent rectangular stress block, in
A	-	Surface area of foundation, ft ²
A _{rs}	-	Area of tension reinforcement, in ²
b	-	Width of compression face, in
B	-	Total width of foundation, in
c	-	Thickness of bottom concrete cover, in
d	-	Distance from extreme compression fiber to centroid of tension reinforcement, in
d _{rb}	-	Diameter of tension reinforcement bar, in
d _{rc}	-	Distance between tension and compression reinforcement, in
d _{rcBw}	-	Distance between tension and compression in reinforcement in back wall
d _{rcF}	-	Distance between tension and compression in reinforcement in foundation
d _{rcsw}	-	Distance between tension and compression in reinforcement in side wall
f _{rc}	-	Friction factor
f' _{rc}	-	Compressive strength of concrete, psi
f _{ds}	-	Dynamic design strength for the reinforcement
f _{dy}	-	Dynamic yield stress of reinforcement, psi
f _{rs}	-	Design stress for reinforcement, psi
f _{ry}	-	Static yield stress of steel, psi
HW	-	Height of wall, ft.
\bar{i}_{rb}	-	Average impulse load, psi-ms
*l _{rcr}	-	Distance to critical section, in

$*l_{fn}$	-	Clear span distance, in
L_{fF}	-	Length of foundation extension, ft
M_{fcr}	-	Applied design moment at critical section, in-lb
M_{fu}	-	Ultimate unit resisting moment, in-lb/in
N	-	Blow count from standard penetration test
NS	-	Number of soil elements
p_{fW}	-	Ratio of area of flexural reinforcement to area of concrete
P_{fcr}	-	Bearing pressure at critical section for shear
P_{fs}	-	Bearing pressure at critical section for bending
T_{fc}	-	Total thickness of foundation, in
TS	-	Thickness of foundation extension, ft
TW	-	Thickness of wall, ft
V_{fc}	-	Allowable concrete shear stress, psi
V_{fs}	-	Shear force at support, lb
V_{fu}	-	Total applied design shear force at critical section, lb or lb/in
W	-	Explosive charge weight, lb
W_{fs}	-	Weight of structure, tons
$[\phi]$	-	Capacity reduction factor
	-	Reinforcement bar diameter
$[\nu]$	-	Poisson's ratio
$[PHI]$	-	Overturning angle

PAGE 328 INTENTIONALLY BLANK

SECTION 8. COMPUTER PROGRAMS

1. GENERAL. Currently a large number of structural mechanics programs are available, most of which utilize finite element methods, finite difference methods or a combination of the two.

a. Finite Element Computer Programs. Four widely used finite element computer programs that have provisions for both static and dynamic structural behavior are listed in Table 34. Their applicability to blast resistant design is indicated by x's and dashes. Additional features of these programs, ADINA, ANSYS, NASTRAN, and STARDYNE are described in their respective manuals.

b. Additional Computer Programs. There are eight additional programs now available to the Navy, which are not as well known as the four described above. These programs offer unique capabilities for blast resistant design and were developed specifically to analyze structures encountered in this area. A brief description of each of these eight programs (DYNFA, OVER, BLAST, CEL SAPS5, BARCS, INSLAB, SINGER, and SDOOR) is presented in the next several paragraphs. Most of these programs were written in FORTRAN IV for the Control Data System, CDC 6600 computer and they are available to the Navy PWC/Ds, EFDs and NAVFACENCOM. The programs are stored in the NAVFACENCOM Library and the user can operate the programs via a time-share or batch terminal by addressing the Control Data Corporation CYBERNET Computer System. Additional information about these programs can be obtained from the Civil Engineering Laboratory, Naval Construction and Battalion Center in Port Hueneme, California.

(1) DYNFA - NONLINEAR ANALYSIS OF FRAME STRUCTURES SUBJECTED TO BLAST OVERPRESSURES.

(a) DYNFA was designed specifically to determine the response of frame structures to time-dependent blast loadings. This program implements a method of analysis which couples a lumped parameter representation of the structure with numerical integration procedure to obtain a solution.

(b) In addition to metal plasticity and other non-linear effects which are accounted for in the program, the P and beam-column effects are also considered. A static analysis routine is included and when utilized, the static nodal displacements and element loads are used as the initial conditions for the dynamic analysis.

(c) The results of the dynamic analysis consist of the deformations of the structure expressed in terms of the nodal displacements and rotations, the axial loads, bending moments and shears in each of the elements, and the plastic deformations expressed in terms of ductility ratios of the elements.

(d) The program is written in FORTRAN IV for execution on the CDC 6600 computer using the Extended (FE) FORTRAN computer. A central memory field length of 170,000 words (octal) is required for execution of the program on this computer.

TABLE 34
Capabilities of Computer Programs

CAPABILITIES	PROGRAM			
	ADINA	ANSYS	NASTRAN	STARDYNE
STATIC	x	x	x	x
DYNAMIC	x	x	x	x
TIME DEPENDENT BOUNDARY DISPLACEMENT	-	x	x	x
GEOMETRIC NON-LINEARITIES	x	x	x	-
ELEMENTS:				
1D	x	x	x	x
2D	x	x	x	x
3D	x	x	x	x

(2) OVER - OVERTURNING AND SLIDING ANALYSIS OF REINFORCED CONCRETE PROTECTIVE STRUCTURES.

(a) This special purpose program is designed specifically for performing dynamic analyses of structures subjected to close-in explosions. To this end, the bulk of the input data required for the dynamic analysis is computed internally by the program.

(b) The response of the structure is determined by performing a time-history dynamic analysis which considers the effect of the supporting soil on the response of the structure. To avoid a rigorous and time-consuming analysis, the structure is treated as a rigid body consisting of infinitely stiff elements. The blast loads and elemental inertial loads are assumed to act through the center of gravity of the structure, thus reducing its response to the motion of its center of gravity.

(c) The results of the analysis consist of the displacement, velocity and acceleration-time histories of the structure, and also the bearing pressures beneath the foundation. Options are included for the computation of the shears and moments for the foundation slab design of cantilever wall barriers and the peak response time for the back wall element designed to the incipient failure or post-failure fragment conditions.

(d) The program contains three optional modes of operation:

1. Normal Option - Used for analyzing the most common types of protective structures encountered in explosive manufacturing and storage facilities.

2. Special Loading Option - Used to accommodate rectangular or trapezoidal load histories in the analysis.

3. General Structure Option - Used to extend the applicability of the program to structures of arbitrary configurations.

(e) OVER is written in FORTRAN IV for the CDC 6600 computer system. A central memory field length of 150,000 words (octal) is required for compilation and execution of the program on the CDC system.

(3) BLAST - BLAST LOADING IN BLAST CELLS.

(a) BLAST is a computer program capable of generating characteristic blast loading parameters associated with confined explosions, such as determining the internal blast environment in a rectangular cell.

(b) The program, using existing state-of-the-art explosion theory, calculates shock pressure and gas pressure. The code includes blast parameters of approximately 20 different explosives. For the initial shock wave, it generates the incident and normally reflected pressure-time histories and impulse for positive phase duration at a specified distance. The code examines shock reflections in a closed or partially closed rectangular structure. Gas pressure generation is computed using the energy of chemical reaction. Venting is determined, giving the gas pressure in various chambers at different times.

(c) The program contains two options:

1. Shock calculation which produces a time history of the pressure at distance from the explosion and

2. An impulse calculation which gives total impulse for each wall. Within this latter option, a grid of impulse may also be computed.

(4) CEL SAP5 - A GENERAL PURPOSE FINITE ELEMENT PROGRAM.

(a) Program CEL SAP5 is a general purpose finite element program for the analysis of two-dimensional and three-dimensional elastic structures subjected to static and dynamic loads. It is well suited to analyze complete structures subjected to blast loading. However, the blast loadings have to be determined prior to code usage.

(b) The computer program is capable of analyzing linear static and dynamic problems using finite element techniques. The structural system that can be analyzed may be composed of combinations of the following elements: three-dimensional truss, two-dimensional plane stress/plane strain element, three-dimensional thin shell, three-dimensional solid element, three-dimensional thick shell and three-dimensional beam. The program is limited to linear elastic material properties and dynamic solutions may be by modal analysis for elastic systems or time-step integration.

(5) BARCS - DYNAMIC NONLINEAR ANALYSIS OF SLABS.

(a) This program is capable of performing dynamic nonlinear analysis and optimized design of rectangular reinforced concrete slabs with various boundary conditions subject to blast pressures. It is intended to perform the approximate design of slabs which form the walls and roofs of reinforced concrete blast cells, similar to those in use in conventional ammunition plants and for hazardous operations in testing missiles for acceptance by the Navy.

(b) The program can compute blast shock and gas pressures based on the type and quantity of explosive. It determines the structural properties of the reinforced concrete slab and then determines the dynamic response of the slab. The procedures used in the program are the same as defined in NAVFAC P-397.

(c) The program computes and prints the blast loading including peak shock pressure, and impulse and peak gas pressure, and impulse. The structural section properties, stiffness and resistance are determined. A dynamic time history of slab response is given up until maximum deflection is reached. Optimization procedures allow for iteration of design to produce the least cost design.

(6) INSLAB - TWO-DIMENSIONAL FINITE ELEMENT PROGRAM.

(a) This program is a general purpose two-dimensional finite element program for performing a bilinear dynamic analysis of plates and beams. It is intended for detailed analysis of complex plates which are not reliably designed by approximate techniques such as built-up or heavy steel blast doors.

(b) The program uses plate and beam finite elements for the solution of two-dimensional problems subject to dynamic distributed or concentrated loading. The material model is a bilinear model defined by yield stress and modulus of elasticity over the two regions. A provision is included to allow for internal hinges and the dynamic response is determined by time-step integrations.

(7) SINGER - TWO-DIMENSIONAL INELASTIC FRAMES.

(a) SINGER is a program used for the analysis of two-dimensional inelastic reinforced concrete frames subject to dynamic loads. It is intended to analyze the static and dynamic inelastic, nonlinear-geometry large deformation behavior of reinforced concrete frames.

(b) The user may model each element of the frames as a composite of longitudinal reinforcing bars confined within a mass of concrete stirrups that have a protective cover of unconfined concrete. Wide flange metal beams may also be included. Loadings may be input as time histories either acting as concentrated or distributed forces. The program predicts the equilibrium position either neglecting or considering inertia effects, allowing large changes in geometry. It models yielding and fracture of materials and elements.

(8) SDOOR - DYNAMIC NONLINEAR ANALYSIS OF PLATES.

(a) SDOOR is a computer program capable of performing dynamic bilinear analysis and optimized design, of rectangular steel plates with various boundary conditions subject to explosive blast pressures. The program is intended to perform the approximate design of built-up and heavy steel blast doors used in blast cells. The procedures used in the program are the same as those outlined in NAVFAC P-397.

(b) The program computes the blast shock and gas pressures based on the given type and quantity of explosive. It determines the structure properties of the plate, computes plate resistance using yield line theory, and determines the dynamic response of the plate.

(c) The results of the dynamic analysis consist of the blast loading (peak shock pressure, gas pressure and impulse), stiffness and resistance of structure, and a dynamic time history of the response of the plate. Optimization procedures allow for automatic interaction of design to produce a least-cost design.

THIS PAGE INTENTIONALLY LEFT BLANK

BIBLIOGRAPHY

Amman & Whitney, Consulting Engineers, 2 World Trade Center, New York, NY
10048

Design of Masonry Structures to Resist the Effects of HE Explosions,
1976

Design of Structures to Resist Atomic Blast, 1954

Arching Action Theory of Masonry Walls, E. McDowell, McKee, and E. Sevin,
Journal of the Structural Division, American Society of Civil Engineers, Vol
82, No ST 2, 1956

Design of Prestressed Concrete Structures, T.Y. Lin, John Wiley & Sons, 605
3rd Ave, New York, NY 10158, 1955

Existing Structures Evaluation - Part 1: Walls, C.K. Wiehle, et al.,
Standford Research Institute, Menlo Park, CA 94025, 1968

MSC/NASTRAN User's Manual, MSR-39, C.W. McCormick, (Editor), The
MacNeal-Schwendler Corp., 815-T W. Colorado Blvd, Los Angeles, CA 90041,
1976

Nonlinear Analysis of Frame Structure Subjected to Blast Overpressures,
ARLCD-CR-77008, W. Stea, prepared for U.S. Army Armament Research and
Development Center, Dover, NJ, 1977

Reinforced Concrete Fundamentals, P.M. Ferguson, John Wiley & Sons, 605 3rd
Ave, New York, NY 10158, 1979

Seismic Design for Buildings, Naval Facilities Engineering Command
(NAVFACENGCOM) Publication P-355, available from Naval Publications and
Forms Center, 5801 Tabor Ave, Philadelphia, PA 19121, 1982

STAR DYNE, Static and Dynamic Structural Analysis Systems, User's Manual,
Mechanics Research, Inc., Santa Monica, CA, 1976

URS Research Corporation, 155-T Bovet Rd, San Mateo, CA 94402

Response of Arching Walls and Debris and Debris From Interior Walls
Caused by Blast Loading, URS 7030-23, Gabrielsen, Wilton, and Kaplan,
1976

Shock Tunnel Tests of Pre-Loaded and Arched Wall Panels, URS 7030-10,
Wilton and Gabrielsen, 1973

PAGE 336 INTENTIONALLY BLANK

REFERENCES

ADINA, A Finite Element Program for Automatic Dynamic Incremental Nonlinear Analysis, Report 82448-1, K.J. Bathe, Massachusetts Institute of Technology, Cambridge, MA 02139, 1975.

The Air Blast from Simultaneously Detonated Explosive Spheres,, BRL No. 1294, B.R. Armendt, R.G. Hippensteel, A.J. Hoffman, and C.N. Kingery, Ballistic Research Laboratories, Aberdeen Proving Ground, MD 21005, 1960

American National Standards Institute, 1430 Broadway, New York, NY 10018

A58.1-82 Minimum Design Loads for Buildings and Other Structures

B18.22.1-85 Plain Washers

American Society for Testing and Materials, 1916 Race Street, Philadelphia, PA 19103

A36A-84 Specification for Structural Steel

A307-84 Specification for Carbon Steel Externally Threaded Standard Fasteners

A325-84 Specification for High-Strength Bolts for Structural Steel Joints

A446M-83 Specification for Sheet Steel, Zinc-Coated (Galvanized) by the Hot-Dip Process, Structural (Physical) Quality

A501-84 Specification for Hot-Formed Welded and Seamless Carbon Steel Structural Tubing

A529M-85 Specification for Structural Steel with 42 ksi (290 MPa) Minimum Yield Point (1/2 in (13mm) Maximum Thickness

A570M-85 Specification for Steel, Sheet and Strip, Carbon, Hot-Rolled, Structural Quality

A572M-85 Specification for High-Strength Low-Alloy Columbium-Vanadium Steels of Structural Quality

ANSYS, Engineering Analysis Systems, User's Manual, G.J. DeSalvo and J.A. Swanson, Swanson Analysis Systems, Inc., Houston, PA 15342, 1979.

Blast Capacity Evaluation of Glass Windows and Aluminum Window Frames, Report ARLCD-CR-78016, S. Weissman, et al., U.S. Army Armament Research and Development Center, Dover, NJ 07801, 1978.

Blast Capacity Evaluation of Pre-Engineered Building, Contractor Report ARLCD-CR-79004, W. Stea, N. Dobbs, S. Weissman, P. Price, and J. Caltagirone, U.S. Army Armament Research and Development Center, Dover, NJ, 1979.

Blast Effects of Simultaneous Multiple Charge Detonations, ARLCD-CRE-78-32, J.C. Hokanson, U.S. Army Armament Research and Development Center, Dover, NJ, 1978.

Blast Environment from Fully and Partially Vented Explosions in Cubicles, Technical Report R828, W.A. Keenan and J.E. Tancreto, Picatinny Arsenal, Dover, N.J., 1975

Blast Pressure from Sequential Explosions, Phase Report II, Project J6166, T.A. Zaker, ITT Research Institute Chicago, IL, 1969.

Building Code Requirements for Reinforced Concrete, ACI 318-83, American Concrete Institute, P.O. Box 19150, Redford Station, Detroit, MI 48219

Characteristics of Plexiglas Fragments from Windows Broken by Airblast, E.R. Fletcher, et al., Lovelace Foundation for Medical Education and Research, Albuquerque, NM, 1974.

Department of Defense Manuals, available from the Government Printing Office, Washington, D.C. 20402

DOD 4125.26 Contractors' Safety Manual for Ammunition and Explosives, 1986

DOD 6055.9-STD Ammunition and Explosives Safety Standards, 1984

Design Charts for Cold-Formed Steel Panels and Wide-Flange Beams Subjected to Blast Loads. TR 4838, G. Tseng, S. Weissman, N. Dobbs, and P. Price, Picatinny Arsenal, Dover, NJ, 1975.

Design of Concrete Structure, 8th Edition, G. Winter and A.H. Nilson, McGraw-Hill, Inc., 1221 Avenue of the Americas, New York, NY 10020, 1972.

Design of Steel Structures the Effects of HE Explosions, Technical Report 4837, J.J. Healey, et al., Picatinny Arsenal, Dover, NJ, 1975.

Designing Facilities to Resist Nuclear Weapon Effects - Structures, TM 5-858-3, Department of the Army Technical Manual, 1984, available from the Government Printing Office, Washington, D.C. 20402

Dynamics of Structures, R.W. Clough and J. Penzien, McGraw-Hill, Inc., 1221 Avenue of the Americas, New York, NY 10020, 1970

ESKIMO I Magazine Separation Test, Naval Weapons Center Technical Publication 5430, F.H. Weals, China Lake, CA, 1973.

ESKIMO II Magazine Separation Test, Naval Weapons Center Technical Publication 5557, F.H. Weals, China Lake, CA, 1974.

ESKIMO III Magazine Separation Test, Naval Weapons Center Technical Publication 5771, F.H. Weals, China Lake, CA, 1976.

Experimental Evaluation of Blast-Resistant Steel Doors, TM 51-79-09, G. Warren, Naval Facilities Engineering Command, Port Hueneme, CA 93043, 1979.

Explosion Effects and Properties; Part 1, Explosion Effects in Air, NSWC/WOL TR 75-116, M.M. Swisdak, Naval Surface Weapons Center, Silver Spring, MD 20903-5000, 1975

Explosions in Air, W.E. Baker, University of Texas Press, Austin, TX 78712

Formulation of an Analysis Methodology for Blast-Resistant Steel Doors, TM 51-79-23, G. Warren, A. Rinnan, and R.J. Odello, Naval Facilities Engineering Command, Port Hueneme, CA 93043, 1978.

Foundation Engineering Handbook, H.F. Winterkorn and H. Fang, Van Nostrand Reinhold Company, New York, NY, 1975.

Glass Engineering Handbook, E.B. Shand, 2nd Edition, McGraw Hill, Inc., 1221 Avenue of the Americas, New York, NY 10020, 1958.

High Explosive Multi-Burst Air Blast Phenomena (Simultaneous and Non-Simultaneous Detonations), Technical Report No. ARBRL-TR-02142, R.E. Reisler, L.W. Kennedy, and J.H. Keefer, Ballistic Research Laboratories, Aberdeen Proving Ground, MD 21005, 1979.

An Improved Computer Program to Calculate the Average Blast Impulse Loads Acting on a Wall of a Cubicle, Technical Report No. 4070, S. Levy, Picatinny Arsenal, Dover, NJ, 1970.

The Initial Velocities of Fragments from Bombs, Shells and Grenades, Report No. 405, R.W. Gurney, Ballistic Research Laboratories, Aberdeen Proving Ground, MD 21005, 1947.

Introduction to Structural Analysis, J.M. Biggs, McGraw-Hill, Inc., 1221 Avenue of the Americas, New York, NY 10020

Loading Characteristics of Air Blasts from Detonating Charges, Report No. 100, S.A. Granstrom, Transactions of the Royal Institute of Technology, Stockholm, Sweden, 1956.

A Manual for the Prediction of Blast and Fragment Loadings on Structures, DOE/TIC 11268, U.S. Department of Energy, 1980, available from U.S. Department of Commerce, National Technical Information Service, Springfield, VA 22161

The Mass Distribution of Fragments from Bombs, Shells and Grenades, Report No. 448, R.W. Gurney, Ballistic Research Laboratories, Aberdeen Proving Ground, MD 21005, 1944.

The Mechanical Properties of Glass, F.W. Preston, Journal of Applied Physics, Vol. 13, No. 10, October 1942.

Overturning and Sliding Analysis of Reinforced Concrete Protective Structures, Technical Report 4921, W. Stea, et al., Picatinny Arsenal, Dover, NJ, 1976.

Plastic Theory of Reinforced Concrete Design, C.S. Whitney, Transactions of the American Society of Civil Engineers, Vol. 107, American Society of Civil Engineers, 345 East 47th Street, New York, NY 10017, 1942.

Prestressed Concrete Institute, 201 North Wells, Suite 1410, Chicago, IL 60606

Design Handbook for Precast Prestressed Concrete, 1985

Manual for Structural Design of Architectural Precast Concrete, 1977

Manual on Design of Connections for Precast Prestressed Concrete, 1973

Primary Fragment Characteristics and Impact Effects on Protective Barriers, Technical Report 4903, J.J. Healey, et al., Picatinny Arsenal, Dover, NJ, 1975.

Response of Glass in Windows to Sonic Booms, R.W. McKinley, Materials Research and Standards, 1964.

Review Comments (Partial List) on Design Drawings and Specifications for Unaccompanied Enlisted Quarters (P-040), Naval Submarine Support Facility, San Diego, CA, W.A. Keenan, (Memorandum to Commanding Officer, Western Division, Naval Facilities Engineering Command), Civil Engineering Laboratory, Port Hueneme, CA 93043, 1981.

Safety Manual, AMCR 385-100, Army Material Command Regulation, 1981, available from the Government Printing Office, Washington, D.C. 20402

Shock Tube Tests of Glazing Materials, MR No. 626, W.J. Taylor and R.O. Clark, Ballistic Research Laboratories, Aberdeen Proving Ground, MD 21005, 1952.

Some Effects of Light Surrounds and Casings on the Blast from Explosives, BRL No. 1218, Ballistic Research Laboratories, Aberdeen Proving Ground, MD 21005, 1963

Specification for Structural Joints Using ASTM A325 or A490 Bolts, Research Council on Structural Connection, c/o Edward R. Estes, Jr., School of Engineering, Old Dominion University, Norfolk, VA 23508

Specification for the Design Fabrication and Erection of Structural Steel for Buildings, 5326-78, American Institute of Steel Construction, 400 North Michigan Ave, Eighth Floor, Chicago, IL 60611

Specification for the Design of Cold-Formed Steel Structural Members, SG-672-83, American Iron and Steel Institute, 1000 16th Street NW, Washington, D.C. 20036

Structural Welding Code, Steel, D1.1-85, American Welding Society, 550 Northwest Lejeune Road, Miami, FL 33126

Structures to Resist the Effects of Accidental Explosions, Naval Facilities Engineering Command (NAVFACENGCOM) Publication P-397, available from Government Printing Office, Washington, D.C. 20402

Structures to Resist the Effects of Accidental Explosions - Class Notes,
W.A. Keenan, Civil Engineering Laboratory, Port Hueneme, CA 93043, 1976.

A Theoretical Formula for the Distribution of Weights of Fragments, AC-3642,
R.I. Mott, Great Britain, 1943.

A Theory of Fragmentation, Army Operational Research Group Memorandum,
113-AC-6427, R. I. Mott, Great Britain, 1943.

Theory of Plates and Shells, S. Timoshenko, McGraw-Hill, Inc, 1221 Avenue of
the Americas, New York, NY 10020, 1940

Uniform Building Code, International Conference of Building Officials, 5360
South Workman Mill Road, Whittier, CA 90601