

**S0300-BB-MAN-010**

---

**0910-LP-111-3300**

**U.S. NAVY  
UNDERWATER  
CUTTING & WELDING  
MANUAL**



**DISTRIBUTION STATEMENT A: THIS DOCUMENT HAS BEEN APPROVED FOR PUBLIC RELEASE AND SALE; ITS DISTRIBUTION IS UNLIMITED.**

**THIS DOCUMENT SUPERSEDES NAVSHIPS 0929-LP-000-8010**

**PUBLISHED BY DIRECTION OF COMMANDER, NAVAL SEA SYSTEMS COMMAND**

---

**1 APRIL 1989**

**Change A Dated 15 September 1995**

**Change B Dated 1 June 2002**

---

**LIST OF EFFECTIVE PAGES**

---

Date of Original Pages is: 1 April 1989  
Date of Change A Pages is: 15 September 1995  
Date of Change B Pages is: 1 June 2002

<b>Page No.* Change No.</b>	<b>Page No</b>	<b>* Change No.</b>
Title and A . . . . . B	2-1 through 2-32 . . . . .	O
Certification Sheet . . . . . B	2-33 through 2-36 . . . . .	B
blank . . . . . O	2-37 through 2-38 . . . . .	O
Change Record . . . . . O	2-39 through 2-40 . . . . .	A
Change Record-2 blank . . . . . O	2-41 through 2-47 . . . . .	O
i . . . . . O	2-48 blank . . . . .	O
ii blank . . . . . O	3-1 through 3-26 . . . . .	O
iii . . . . . A	4-1 through 4-29 . . . . .	O
iv . . . . . B	4-30 . . . . .	B
v through viii. . . . . O	A-1 through A-2. . . . .	O
ix . . . . . B	B-1 through B-2. . . . .	O
x through xiii. . . . . O	C-1 . . . . .	O
xiv blank . . . . . O	C-2 blank . . . . .	O
xv through xxiii. . . . . A	D-1 through D-14. . . . .	A
xxiv blank . . . . . A	E-1 through E-28 . . . . .	O
1-1 . . . . . O	Glossary-1 through Glossary-4 . . . . .	O
1-2 . . . . . B	Index-1 . . . . .	B
1-3 . . . . . O	Index-2 through Index-4 . . . . .	A
1-4 blank . . . . . O		

\* 0 in this column indicates an original page.

DEPARTMENT OF THE NAVY  
NAVAL SEA SYSTEMS COMMAND  
WASHINGTON, D.C. 20362

NAVSEA S0300-BB-MAN-010  
U.S. NAVY UNDERWATER CUTTING & WELDING MANUAL

0910-LP-111-3301  
CHANGE B  
1 June 2002

PUBLISHED BY DIRECTION OF  
COMMANDER, NAVAL SEA SYSTEMS COMMAND

---

NAVSEA S0300-BB-MAN-010 is changed as follows:

1. Remove old pages and insert new pages as indicated in instruction below. Dispose of superseded pages in accordance with applicable regulations.
2. New or changed material is indicated by a vertical bar in the margin of the page.

REMOVE PAGES

TITLE AND A  
CERT SHEET  
iv  
ix  
1-2  
2-33 through 2-36  
4-30  
Index-1

INSERT PAGES

TITLE AND A  
CERT SHEET  
iv  
ix  
1-2  
2-33 through 2-36  
4-30  
Index-1

After the attached enclosures have been inserted, record this CHANGE on the Record of Changes sheet and insert this page behind the Title page.

Request for additional copies of this CHANGE shall be submitted to Commanding Officer, Naval Publications and Form Center, 5801 Tabor Avenue, Philadelphia, PA 19120-5099.

---

CHANGE INSTRUCTIONS  
SHEET 1 OF 1

**NAVSEA TECHNICAL MANUAL CERTIFICATION SHEET**1 of 1Certification Applies to:    New Manual             Revision             Change 

Applicable TMINS/Pub. No.    S0300-BB-MAN-010

Publication Date (Mo, Da, Yr) Original Manual, 1 April 1989; Change B Pages, 1 June 2002

Title: U.S. NAVY UNDERWATER CUTTING AND WELDING MANUAL

TMCR/TMSR/Specification No.: \_\_\_\_\_

**CHANGES AND REVISIONS:**Purpose: Change B updates information on Kerie Cable Thermal Arc Cutting System

Equipment Alteration Numbers Incorporated: \_\_\_\_\_

TMDER/ACN Numbers Incorporated: \_\_\_\_\_

*Continue on reverse side or add pages as needed.***CERTIFICATION STATEMENT**

This is to certify that responsible NAVSEA activities have reviewed the above identified document for acquisition compliance, technical coverage, and printing quality. This form is for internal NAVSEA management use only, and does not imply contractual approval or acceptance of the technical manual by the Government, nor relieve the contractor of any responsibility for delivering the technical manual in accordance with the contract requirement.

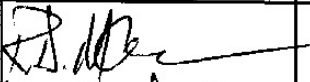
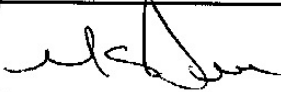
Authority	Name	Signature	Organization	Code	Date
Acquisition	R. McClellan		NAVSEA	00C56	5/14/02
Technical	M. S. DEAN		NAVSEA	00C5	7/18/02
Printing Release					

S0300-BB-MAN-010

---

**RECORD OF CHANGES**

---

CHANGE NO.	DATE OF CHANGE	TITLE AND/OR BRIEF DESCRIPTION	ENTERED BY
A	15 Sep 1998	Changes affect front matter, Chapter 2 and Appendix D	KLB
B	1 Jun 2002	Changes to Kerie Cable Thermal Arc Cutting System	FSL

S0300-BB-MAN-010

---

## FOREWORD

---

Ship Salvage, Harbor Clearance and Wreck Removal oftentimes require extensive underwater cutting and welding. The lack of recent fleet experience in these areas dictates the need for a manual that incorporates state of the art equipment and tried and proven underwater cutting and welding techniques. The knowledge contained in this manual is a collection of fleet and commercial experience. It has been reviewed by technical experts with extensive salvage and underwater cutting and welding experience.

This revision of the Underwater Cutting and Welding Manual has been prepared to provide the most current information on equipment and procedures available. All of the equipment covered may not be found on the Diving Equipment Authorized for Navy Use (ANU) list (NAVSEAINST 10560.2), but is included in this manual as an aid to the salvor who finds himself in a “must get the job done” situation. Further guidance can be found in [Appendix E](#).

Due to limited time allocation, there is a lack of realistic underwater cutting and welding training in the Navy’s diving schools. Students are given only the basics in school and thereafter must practice to become proficient and gain the experience necessary to become “qualified underwater cutters and welders.” I therefore charge all diving officers, master divers and diving supervisors to establish or maintain existing training programs for underwater cutting and welding. Practice, practice, practice.

C.A. BARTHOLOMEW  
Director of Ocean Engineering  
Supervisor of Salvage and Diving, USN

---

## TABLE OF CONTENTS

---

<b>Chapter/Paragraph</b>	<b>Page</b>
FOREWARD .....	i
TABLE OF CONTENTS.....	iii
LIST OF ILLUSTRATIONS.....	ix
LIST OF TABLES.....	xi
STANDARD NAVY SYNTAX SUMMARY .....	xiii
SAFETY SUMMARY .....	xv
<b>1 INTRODUCTION</b>	
1-1 SCOPE .....	1-1
1-2 UNDERWATER CUTTING OVERVIEW.....	1-1
1-3 UNDERWATER WELDING OVERVIEW .....	1-2
<b>2 UNDERWATER CUTTING</b>	
2-1 INTRODUCTION .....	2-1
2-2 OXYGEN-ARC CUTTING .....	2-2
2-2.1 Principles of Operation .....	2-2
2-2.2 Steel-Tubular Electrodes.....	2-2
2-2.2.1 Advantages of the Steel-Tubular Electrodes .....	2-5
2-2.2.2 Disadvantages of the Steel-Tubular Electrode.....	2-5
2-2.3 Electrode Amperage Requirements .....	2-5
2-2.4 Oxygen Requirements.....	2-6
2-2.5 Material Consumption .....	2-6
2-2.6 Oxygen Pressure .....	2-6
2-2.7 Oxygen Purity .....	2-11
2-2.8 Grounding the Work .....	2-11
2-2.9 Steel-Tubular Electrode Cutting Technique (Thick plate) .....	2-11
2-2.10 Steel-Tubular Electrode Cutting Technique (Thin plate) .....	2-15
2-2.11 Piercing Holes in Steel Plate.....	2-15
2-2.12 Steel-Tubular Electrode Cutting Technique (Cast Iron and Non-Ferrous Metals) .....	2-18
2-2.13 Post-dive Maintenance.....	2-18
2-3 EXOTHERMIC ELECTRODES.....	2-22
2-3.1 Electrode Amperage Requirements .....	2-22
2-3.2 Oxygen Requirements.....	2-25
2-3.3 Material Consumption .....	2-25
2-3.4 Advantages and Disadvantages of the Exothermic Electrode Cutting Process .....	2-25
2-3.4.1 Disadvantages of Exothermic Electrodes .....	2-27
2-3.5 Grounding the Work .....	2-27

## S0300-BB-MAN-010

2-3.6	Exothermic Cutting Technique .....	2-28
2-3.6.1	Exothermic Cutting Technique (Cast Iron, Stainless Steel and Non-Ferrous Metals).....	2-30
2-3.6.2	Exothermic Cutting Technique (Concrete, Rock and other Non-Conductive Materials) .....	2-31
2-3.6.3	Exothermic Hole Piercing.....	2-31
2-3.7	Trouble Shooting.....	2-31
2-3.7.1	Symptoms .....	2-31
2-3.7.2	Probable Causes.....	2-32
2-3.7.3	Locating and Solving the Problem.....	2-32
2-3.8	Post-Dive Maintenance.....	2-33
2-4	SEELER ENTERPRISES LU-001 EXOTHERMIC CUTTING TOOL (KERIE CABLE).....	2-33
2-4.1	Advantages and Disadvantages of the of the Kerie Cable.....	2-34
2-4.2	Materials Required for Kerie Cable Cutting.....	2-35
2-4.3	Equipment Set-up .....	2-37
2-4.4	Kerie Cable Preparation.....	2-39
2-4.5	Cutting Underwater.....	2-39
2-4.6	Cutting Technique.....	2-40
2-4.7	Cutting Thin Metals.....	2-40
2-4.8	Cutting Thick Metals .....	2-41
2-4.9	Re-Lighting Cable Underwater.....	2-43
2-4.10	Emergency Off Safety Procedures.....	2-43
2-4.11	Loss of Communications .....	2-43
2-4.12	Equipment Tender.....	2-43
2-4.13	Electrical Precautions .....	2-43
2-4.14	Post-Dive Maintenance.....	2-43
2-5	SHIELDED METAL ARC CUTTING.....	2-44
2-5.1	Principles of Operation .....	2-44
2-5.2	Materials .....	2-44
2-5.3	Waterproofing Electrodes .....	2-44
2-5.4	Underwater Shielded Metal-Arc Cutting Techniques.....	2-45
2-5.5	Drag Technique.....	2-46
2-6	CONCLUSION.....	2-46

**3 UNDERWATER WELDING**

3-1	INTRODUCTION .....	3-1
3-2	MECHANICAL BARRIERS .....	3-2
3-2.1	Cofferdams and Caissons.....	3-2
3-2.2	Mini-Habitats .....	3-2
3-3	SHIELDED METAL-ARC WELDING .....	3-3
3-4	WET WELDING .....	3-3
3-5	SHIPBUILDING MATERIALS .....	3-3



## S0300-BB-MAN-010

3-6	MATERIALS USED IN UNDERWATER SHIELDED METAL-ARC WELDING.....	3-6
3-6.1	Underwater Shielded Metal-Arc Welding Electrodes .....	3-6
3-6.2	Tong Test Ammeter .....	3-6
3-6.3	Electrode Polarity .....	3-6
3-7	UNDERWATER WELDING ARCS .....	3-8
3-8	CONDITIONS ADVERSE TO UNDERWATER WELDING.....	3-8
3-9	STRENGTH OF UNDERWATER FILLET WELDS .....	3-10
3-9.1	Parts of a Weld (Definitions) .....	3-10
3-9.2	Fillet Weld .....	3-12
3-9.3	Trial Weld .....	3-12
3-10	SURFACE CLEANING .....	3-12
3-11	JOINT FIT-UP .....	3-13
3-12	UNDERWATER SHIELDED METAL-ARC WELDING TECHNIQUES .....	3-13
3-12.1	Welding Set-Up Procedures.....	3-13
3-12.2	Self-Consuming Technique .....	3-14
3-12.3	Fillet Welding in the Horizontal Position (Self-Consuming Technique) ...	3-14
3-12.3.1	Fillet Welding in the Vertical Position .....	3-17
3-12.3.2	Fillet Welding in the Overhead Position.....	3-17
3-12.3.3	Self-Consuming and Manipulative Techniques.....	3-20
3-12.3.4	Fillet Welding Where There is Poor Fit-Up .....	3-20
3-12.4	Welding on Thin Plates.....	3-20
3-13	PROCEDURE FOR REPAIRING SMALL CRACKS .....	3-22
3-13.1	Using a Rectangular Patch .....	3-22
3-13.2	Using a Circular Patch .....	3-22
3-14	POST-DIVE MAINTENANCE .....	3-25
<b>4</b>	<b>UNDERWATER ARC CUTTING AND WELDING EQUIPMENT</b>	
4-1	INTRODUCTION .....	4-1
4-2	EQUIPMENT USED FOR UNDERWATER ARC CUTTING AND WELDING .....	4-1
4-2.1	Oxygen-Arc and Shielded Metal-Arc Equipment .....	4-1
4-2.2	Diving Equipment.....	4-1
4-2.2.1	Welding Shields .....	4-1
4-2.3	Power Supply Requirements.....	4-9
4-2.3.1	Power Converters.....	4-9
4-2.3.2	Welding Generator, Pre-Setup Inspection .....	4-11
4-2.3.3	Polarity .....	4-11
4-2.3.4	Polarity test .....	4-11
4-2.3.5	Tong Test Ammeter .....	4-13
4-2.3.6	Amperage and Voltage .....	4-13
4-2.3.7	Diesel Driven Welding Generator Amperage and Voltage Settings .....	4-15

## S0300-BB-MAN-010

4-2.4	Safety Switches .....	4-16
4-2.5	Power Cables and Connectors .....	4-16
4-2.6	Gas Manifolds .....	4-17
4-2.7	Underwater Oxygen-Arc Cutting Torches .....	4-17
4-3	EQUIPMENT FOR UNDERWATER SHIELDED METAL-ARC WELDING .....	4-19
4-3.1	Electrode Holders .....	4-19
4-4	WELDING ACCESSORIES .....	4-20

<b>Appendix</b>	<b>Page</b>
-----------------	-------------

**A DOCUMENTATION MATRIX**

A-1	PURPOSE .....	A-1
A-2	REFERENCE DOCUMENTS .....	A-1

**B METRIC CONVERSION FACTORS**

English and Metric Equivalents .....	B-1
Weights .....	B-2
Measures .....	B-2
Pressure or Stress (Force/Area) .....	B-3
Temperature Conversion .....	B-3
Metric Prefixes .....	B-3
Multiplication Factors .....	B-3

**C BIBLIOGRAPHY .....** C-1**D SAFETY IN UNDERWATER CUTTING AND WELDING**

D-1	PURPOSE .....	D-1
D-2	GENERAL .....	D-1
D-3	EXPLOSIVE GASES .....	D-1
D-3.1	General Information .....	D-2
D-3.2	Specific Information .....	D-2
D-4	ELECTRICITY UNDERWATER .....	D-4
D-5	GENERAL PRECAUTIONS FOR UNDERWATER CUTTING AND WELDING .....	D-4
D-6	POWER SUPPLY .....	D-5
D-7	ELECTRODE HOLDERS AND CUTTING TORCHES .....	D-6
D-8	POWER CABLES AND CONNECTORS .....	D-7
D-9	SAFETY SWITCH .....	D-8

## S0300-BB-MAN-010

D-10	FIRE AND EXPLOSION PREVENTION .....	D-9
D-10.1	Major Causes .....	D-10
D-11	COMPRESSED GAS SUPPLIES .....	D-10
D-11.1	Use, Handling and Storage of Compressed Gases.....	D-10
D-11.1.1	The Never List .....	D-10
D-11.1.2	The Always List.....	D-11
D-11.1.3	General Oxygen Precautions .....	D-12
D-11.1.4	General MAPP Gas Precautions .....	D-12
D-11.2	Additional Safety Precautions .....	D-13
D-12	PERSONAL SAFETY IN DIVING .....	D-14
D-12.1	Diving Dress .....	D-14
D-13	CONCLUSION.....	D-14

**E EXCEPTIONAL SITUATIONS**

E-1	PURPOSE.....	E-1
E-1.1	Discussion.....	E-1
E-1.2	Authorization .....	E-1
E-2	UNDERWATER CUTTING EQUIPMENT .....	E-1
E-2.1	Arcwater Cutting.....	E-1
E-2.2	Principles of Operation .....	E-2
E-2.3	Applications .....	E-2
E-2.4	Necessary Equipment .....	E-2
E-2.4.1	Power .....	E-2
E-2.4.2	Water.....	E-2
E-2.4.3	Arcwater torch .....	E-2
E-2.4.4	Electrodes.....	E-2
E-2.5	Arcwater Electrode Cutting Technique .....	E-4
E-2.5.1	Underwater Preparations.....	E-4
E-2.5.1.1	Cutting .....	E-4
E-2.5.1.2	Gouging .....	E-4
E-2.6	Material Consumption .....	E-5
E-2.7	Post-Dive Maintenance.....	E-5
E-3	CUTTING UNDERWATER WITH THERMIC LANCE (BURN BARS).....	E-5
E-3.1	Material Description .....	E-7
E-3.2	Required Equipment .....	E-8
E-3.3	Set Up Procedure .....	E-8
E-3.4	Material Consumption .....	E-10
E-4	MAPP GAS CUTTING .....	E-10
E-4.1	Principles of Operation .....	E-10
E-4.2	Equipment and Material.....	E-11
E-4.3	Protective Clothing .....	E-12
E-4.4	Cylinders and Regulators.....	E-12
E-4.4.1	Purging the Hoses .....	E-12
E-4.5	Underwater MAPP Gas Cutting Torches.....	E-14

## S0300-BB-MAN-010

E-4.6	Igniting the Torch Above Water .....	E-16
E-4.6.1	Preparation .....	E-16
E-4.6.2	Ignition .....	E-16
E-4.7	Lowering the Ignited Torch .....	E-18
E-4.8	Underwater Cutting.....	E-18
E-4.8.1	Starting the Cut at the Edge of a Plate .....	E-18
E-4.8.2	Starting the Cut at the Central Portion of a Plate.....	E-18
E-4.8.3	Advancing the Cut .....	E-21
E-5	UNDERWATER WELDING.....	E-22
E-5.1	Waterproofing Surface Electrodes.....	E-22
E-5.2	Preparation for Underwater Shielded Metal Arc Welding .....	E-24
E-6	LOSS OF VOICE COMMUNICATIONS .....	E-26
E-7	FRICTION STUD WELDER.....	E-26
E-7.1	Principle of Operation.....	E-26
E-7.2	Advantages.....	E-26
E-7.3	Equipment Requirements.....	E-27
E-7.3.1	Equipment Details.....	E-27
	Glossary .....	Glossary-1
	Index .....	Index-1

---

## LIST OF ILLUSTRATIONS

---

<b>Figure Title</b>	<b>Page</b>
2-1 Underwater Oxygen-Arc Cutting Electrodes.....	2-3
2-2 Underwater Oxygen-Arc Electrode Designs .....	2-4
2-3 Drag Techniques for Cutting Steel with Steel-Tubular Electrodes .....	2-12
2-4 Technique for Cutting Steel Less Than 1/4 Inch with Steel-Tubular Electrodes .....	2-16
2-5 Technique for Piercing Holes in Steel Plate using the Oxy-Arc Process with Steel Tubular Electrodes.....	2-17
2-6a Underwater Oxygen-Arc Cutting Torch Breakdown (Arcair).....	2-19
2-6b Underwater Oxygen-Arc Cutting Torch Breakdown (BROCO) .....	2-20
2-6c Underwater Oxygen-Arc Cutting Torch Breakdown (Craftsweld) .....	2-21
2-7 Technique for Cutting Steel Using Exothermic Electrode .....	2-29
2-8 Seeler Kerie Cable Control Panel .....	2-36
2-9 Typical Kerie Cable Set Up .....	2-38
2-10 Technique for Underwater Shielded Metal-Arc Cutting of Thick Plate and Round Stock.....	2-47
3-1 Test Specimen for Tee Fillet Weld .....	3-5
3-2 The Underwater Welding Arc.....	3-9
3-3 Parts of a Weld.....	3-11
3-4 Self-Consuming Technique for Underwater Shielded Metal Arc Welding of Horizontal Fillet Welds .....	3-16
3-5 Self-Consuming Technique for Underwater Shielded Metal Arc Welding of Vertical Fillet Welds.....	3-18
3-6 Technique for Underwater Shielded Metal Arc Welding of Overhead Fillet Welds.....	3-19

## S0300-BB-MAN-010

3-7	Feeding-In Technique for Underwater Shielded Metal Arc Welding of Fillet Welds in Wide-Gap Joints.....	3-21
3-8	Repair Method for Cracks in Underwater Structures Using a Rectangular Patch.....	3-23
3-9	Repair Methods for Cracks in Underwater Structures Using a Circular Patch.....	3-24
3-10	A Typical Underwater Welding Electrode Holder .....	3-26
4-1	Typical Arrangement of Underwater Arc Cutting Equipment .....	4-2
4-2	MK12 SSDS Welding Shield .....	4-3
4-3	MK1, MOD 0 Mask and Lens Holder Assembly .....	4-4
4-4	Superlite-17B/NS Helmet and Lens Holder Assembly .....	4-5
4-5	MK 12 Helmet Lens Holder Assembly with Parts Identification.....	4-6
4-6	Superlite-17B/NS Welding Lens Holder with Parts Identification .....	4-7
4-7	Typical Welding Generator and Power-Converter Control Panel .....	4-10
4-8	Equipment Arrangement for Welding and Cutting Straight Polarity .....	4-12
4-9	Tong Test Ammeter .....	4-14
4-10	Voltage Drop in Welding Cables.....	4-18
E-1	Arcwater Torch Assembly .....	E-3
E-2	Thermic Lance Holder Assembly .....	E-9
E-3	Standard Thermic Lance Equipment Set Up .....	E-9
E-4	Standard Surface Cutting Torch with Underwater Spacer Sleeve.....	E-15
E-5	Starting the Cut at the Edge of a Plate .....	E-19
E-6	Starting a Cut in the Central Portion of a Plate.....	E-20
E-7	Restarting the Cut .....	E-21
E-8	Friction Stud Welder.....	E-28

## S0300-BB-MAN-010

---

**LIST OF TABLES**

---

<b>Table</b>	<b>Title</b>	<b>Page</b>
2-1	Cutting Amperage Requirements for Steel-Tubular Electrodes .....	2-6
2-2	Oxygen Regulator Settings for Oxygen-Arc Cutting Electrodes (Hose Lengths 50 Foot and 200 Foot).....	2-7
2-3	Material Consumption using Steel-Tubular Electrodes .....	2-10
2-4	Recommended Power Settings for Cable Length/Size for Ultrathermic Electrodes .....	2-24
2-5	Exothermic Electrode Consumption Guide .....	2-26
2-6	Oxygen Regulator Settings for Kerie Cable Cutting .....	2-41
2-7	Kerie Cable Size/Metal to be cut .....	2-42
2-8	Kerie Cable Oxygen and Cable Consumption Ratio .....	2-42
2-9	Material Requirements for Underwater Shielded Metal-Arc Cutting .....	2-45
3-1	Guide to Steels and Electrodes for Wet Welding .....	3-4
3-2	Electrodes for Underwater Shielded Metal Arc Welding.....	3-7
3-3	Recommended Amperage Settings for Wet Welding to Depths of 50 Feet .....	3-7
4-1	Recommended Equipment for Underwater Arc Cutting and Welding.....	4-8
4-2	Equipment Load-out for Wet Cutting/Welding Operations .....	4-22
4-3	List of Manufacturers.....	4-26
4-4	Parts Information .....	4-28
A-1	Salvage Documentation Matrix .....	A-2
E-1	Arcwater Operating Data Cutting Carbon Steel .....	E-6
E-2	Equipment and Material Requirements for Underwater MAPP Gas Cutting .....	E-11
E-3	Regulator Gauge Settings .....	E-13
E-4	Recommended Cutting Tip Sizes .....	E-14
E-5	Recommended Pressure Settings and Hose Size Selection Chart .....	E-17
E-6	Surface Welding Electrodes Suitable for Wet Welding .....	E-23
E-7	Recommended Amperage Settings for Wet Welding to Depths of 50 FSW .....	E-25

S0300-BB-MAN-010



S0300-BB-MAN-010

---

## **STANDARD NAVY SYNTAX SUMMARY**

---

This manual utilizes standard Navy syntax as pertains to permissive, advisory, and mandatory language. The concept of word usage and intended meaning which has been adhered to in preparing this manual is as follows:

“Shall” has been used only when application of a procedure is mandatory.

“Should” has been used only when application of a procedure is recommended.

“May” and “need not” have been used only when application of a procedure is discretionary.

“Will” has been used only to indicate futurity; never to indicate any degree of requirement for application of a procedure.

Throughout the manual “electrode” and “rod” have been used interchangeably.

S0300-BB-MAN-010

---

## SAFETY SUMMARY

---

This Safety Summary contains all specific WARNINGS and CAUTIONS appearing elsewhere in this manual. Should situations arise that are not covered by the general and specific safety precautions, the Commanding Officer or other authority will issue orders, as deemed necessary, to cover the situation.

### GUIDELINES

Extensive guidelines for safety can be found in the OPNAV 5100 Series instruction manual, "Navy Safety Precautions." Personnel required to perform underwater cutting or welding operations shall be graduates of a U. S. Navy Diving School, thoroughly trained and equipped not only to perform routine underwater and "top-side" procedures but also to react appropriately to unusual or non-routine situations.

Diving Officers, Diving Supervisors and members of dive teams likely to be involved in salvage requiring underwater cutting or welding should continuously conduct safety indoctrination lectures and exercises aimed at reducing hazards and at reacting appropriately to unusual situations.

### PRECAUTIONS

The WARNINGS and CAUTIONS contained in this manual and listed below are referenced by page number. In addition, the general precautions listed below are offered as part of this Safety Summary. All personnel responsible for or engaged in underwater cutting or welding should:

- Read and comprehend this manual.
- Observe all warnings, cautions and notes listed herein.
- Know the capabilities of assigned equipment and strictly follow operational procedures.

Definitions of warnings and cautions are as follows:

#### WARNING

**A statement used to call particular attention to an action or procedural step which, if not strictly followed, could result in the injury or death of personnel.**

S0300-BB-MAN-010

**CAUTION**

A statement used to provoke notice, awareness, and attention from personnel regarding an action or procedural step which, if not followed, could result in possible injury or equipment malfunction.

The following warning and caution statements appear in this manual and are repeated here for emphasis:

**WARNING**

**Serious injury or death may result when adequate precautions are not followed during underwater cutting or welding operations. Supervisors shall ensure that all personnel become thoroughly familiar with the safety precautions covered in Appendix D. (pages 2-1, 3-1)**

**WARNING**

**Under no circumstances shall compressed air be substituted for oxygen in underwater cutting operations due to the danger of contaminating oxygen regulators and hoses with oil residue (hydrocarbons). (page 2-1)**

**WARNING**

**The position of the ground in relation to the diver must be such that at no time does the diver or equipment become positioned between the ground and the electrode. The diver must avoid becoming part of the electrical circuit. (pages 2-1, 2-26, 3-1, D-7, E-4)**

S0300-BB-MAN-010

**WARNING**

**AC power shall not be used for underwater cutting and welding due to the extreme danger involved with AC current underwater. Electrical shock produced by AC current prevents voluntary relaxation of the muscles controlling the hand. Consequently, the diver may be unable to let go if his body or equipment accidentally enters the electrical circuit. (pages 2-2, 3-1, 4-9, D-3)**

**WARNING**

**When the electrode has been consumed to within 3 inches of the torch, stop the cut and signal for SWITCH OFF before attempting to change electrodes. Maintain the torch in the cutting position until the tender (phone talker) acknowledges SWITCH OFF. Then tap the electrode twice to make sure the current is off. This safety precaution is mandatory, regardless of the type of electrode being used. (page 2-14)**

**WARNING**

**Hydrocarbons ignite almost spontaneously in the presence of oxygen. Never allow oxygen-carrying components to come in contact with oil or grease. (pages 2-18, D-10)**

**WARNING**

**It is unsafe to operate the torch without the flash arrestor in place. To do so may cause injury and/or destroy the torch. (pages 2-22, 4-17)**

S0300-BB-MAN-010

**WARNING**

**Never get between the electrode holder and the striker plate (ground) when the switch is on. (page 2-31)**

**WARNING**

**Do NOT attempt to speed up the cutting by creating a fire or inferno deep inside the metal. Such a situation can lead to an explosion. (pages 2-33, D-1)**

**WARNING**

**The Kerie Cable WILL NOT cut rock or concrete either above or below water. To attempt to do so may create an explosion causing serious injury or death. (page 2-33)**

**WARNING**

**The equipment should not be used to cut non-ferrous metals underwater since they do not oxidize and have to be melted. Experience has shown that this can result in a violent explosion which could be fatal. (page 2-34)**

**WARNING**

**It is very important that ignition NOT occur with oxygen pressure too low. To do so will cause the cable to burn inside itself, and as full pressure is applied, the flame will burn out sideways along the length of the cable in a series of blow holes that can cause diver injury. (page 2-37)**

S0300-BB-MAN-010

**WARNING**

Oxygen partial pressure increases with water depth, thereby creating a fire hazard in habitat environments. No habitat welding will be performed in an air environment at depths greater than 60 FSW. Habitats shall be filled with an inert gas at depths greater than 60 FSW. (page 3-2)

**WARNING**

A diver is at risk to severe electrical shock when performing a cutting or welding operation while only partially immersed in water. Hence, the splash zone is the most hazardous location in which a diver can be placed. (page D-2)

**WARNING**

**NEVER** bring a cutting torch into a bell with the oxygen on or with the welding generator running. (page D-2)

**WARNING**

When the arcwater electrode has been consumed to within 1.5 inches of the torch, stop the cut and signal for SWITCH and water OFF before changing the electrode. Maintain the torch in the cutting position until the tender signals SWITCH OFF. Then tap the electrode twice to make sure the current is off. This safety precaution is mandatory, regardless of the type of electrode used. (page E-5)

S0300-BB-MAN-010

**WARNING**

**This process produces large quantities of hydrogen gas. When combined with oxygen, these concentrations are highly explosive and will produce random explosions of some magnitude. Several divers engaged in salvage work have been killed using this process. (page E-5)**

**WARNING**

**Thermic Lances or Burn Bars are NOT to be used by divers while underwater or by topside personnel performing a cut below the waterline while a diver is in the water. However, during situations where it would be impossible to place a diver in position for cutting and where the cutting can be accomplished from the surface, the Thermic Lance may be used with EXTREME CAUTION! (page E-6)**

**WARNING**

**Always wear protective clothing when using the Thermic lance: full protective suit, leather gloves, tinted face shield, and a hard hat. (page E-7)**

**WARNING**

**Acetylene is very unstable at pressures above 15 psi, and is NOT used for underwater cutting. (page E-10)**

S0300-BB-MAN-010

**CAUTION**

The hand should never be closer than 4 inches from the electrode tip. Therefore, as the electrode is consumed and becomes manageable, the pool que grip can be released. (page 2-14)

**CAUTION**

Pushing the electrode into the hole too fast will result in a shower of spatter, which may damage the diving equipment and/or result in a blow-back. (page 2-15)

**CAUTION**

It is important that the proper washer-collet combination is used. An oversize washer will allow the electrode to bottom on the flashback arrestor, creating electrolysis and possible arcing. An undersize washer will restrict the flow of oxygen to the larger bore electrodes, causing inefficient cutting. (page 2-22)

**CAUTION**

Unlike steel-tubular rods that stop burning the instant the electrical circuit is broken, the exothermic electrodes will continue to burn as long as oxygen is flowing through the electrode. (page 2-25)



S0300-BB-MAN-010

**CAUTION**

When the electrode burns down to within 3 inches of the torch, call for SWITCH OFF. Release the trigger to extinguish the electrode, since it will continue to burn when the electrical power is off with oxygen still flowing. Do NOT attempt to use the last 3 inches of the electrode. To do so will subject the torch to unnecessary heat and possible damage. (page 2-27)

**CAUTION**

Burning the electrode shorter than the 3-inch minimum can damage the torch interior. (page 2-30)

**CAUTION**

Ensure that the red insulating sleeve is correctly reinstalled after replacing the Kerie Cable. (page 2-36)

**CAUTION**

Do not force or poke the cable into the material being cut, since this will cause blow-back. (page 2-40)

**CAUTION**

Due to the flammability and toxicity of fumes from waterproofing compounds, waterproofing must be conducted in a well-ventilated space, clear of any open flames or spark-producing machinery. (page 2-44, E-21)

S0300-BB-MAN-010

**CAUTION**

Arcing can damage welding machine switch contacts. DO NOT change the Range Switch position while welding or under load. Arcing causes pitting and will eventually render the contacts inoperative. (page 4-15)

**CAUTION**

When AC power is required for underwater lighting or operation of hand tools, the AC equipment must be protected by ground-fault detection (GFD) and/or ground-fault interruption (GFI) devices. (page D-8)

**CAUTION**

It is extremely important to mount the switch correctly. The switch must be positively acting, rigidly mounted, and located so that it cannot be accidentally knocked or vibrated closed. Should the switch fall, the circuit would be broken. (page D-8)

**CAUTION**

Sparkless tools are made of an alloy containing beryllium, which is extremely poisonous. DO NOT buff, steel wire brush, or grind tools containing beryllium as this action will release particles, dust or vapors which may be ingested. Obtain medical attention as soon as possible should cuts or ingestion occur. Consider all reddish, copper-colored tools as containing beryllium until, or unless, it is known otherwise. Such tools are not usually marked when they contain beryllium. Although, they may be marked with a Low-Mu mark. (page D-14)

S0300-BB-MAN-010

**CAUTION**

Keep all Thermic lance materials away from oil and/or grease.  
(page E-7)

S0300-BB-MAN-010

---

## CHAPTER 1

---

### INTRODUCTION

#### 1-1 SCOPE

This manual is intended to provide information on the use of conventional techniques for cutting and welding metals underwater. It is written for the U.S. Navy diver who specializes in ship salvage and harbor clearance operations. It is not a procedural guide for certifiable welding used in pre-planned underwater ship husbandry applications.

Divers who perform underwater cutting and welding must have greater skill and stamina than those doing the same work topside. The success and speed of operations depend upon the conditions under which the diver must work because the underwater environment imposes numerous limitations and restrictions on the operator and equipment. The diver is often restricted to working for only a short time on the bottom, particularly at deeper depths. The use of correct techniques and equipment becomes extremely important in terms of work accomplished per hour. Diving apparel, great depth, adverse currents, low temperature, lack of visibility and unstable footing are all factors which make underwater cutting and welding difficult.

Whenever practical, cutting techniques are preferred over welding during ship salvage operations. For example, when wrecking in place is the salvage technique, a chain reeved through two holes cut in the hull and around a transverse frame is the preferred attachment method over a welded padeye.

Only personnel trained and qualified in underwater cutting and welding may be assigned to use the procedures and techniques described herein. Additionally, the procedures in this manual must be carried out in conformance with the *U.S. Navy Diving Manual* (NAVSEA 0994-LP-001-9010) and standard Navy safety practices. [Appendix D](#) covers safety in greater detail.

#### 1-2 UNDERWATER CUTTING OVERVIEW

There are two underwater cutting processes currently approved for Navy use. They are:

- Oxygen-Arc cutting with exothermic electrodes, Steel-tubular electrodes and Kerie Cable; and,
- Shielded metal-arc cutting.

Of these, oxygen-arc (oxy-arc) is preferred because of its ease of use.

Two types of electrodes (also called rods) are used for oxy-arc cutting: the exothermic and

## S0300-BB-MAN-010

the steel-tubular electrode. Of these, the exothermic is preferred because it will burn independently after an arc is struck and oxygen is flowing.

Included in this manual is the Seeler Enterprises LU-001 Exothermic Cutting Tool (Kerie Cable), which operates on the same principal as the exothermic electrode.

The second method of underwater cutting is the shielded metal-arc process in which the metal is cut by the intense heat of the arc without the use of oxygen. This method is preferred over oxy-arc when cutting metal of 1/4-inch or less in thickness or when cutting non-ferrous or corrosion-resistant metal of any thickness.

Each underwater cutting method is covered in detail in [Chapter 2](#).

### 1-3 UNDER WATER WELDING OVERVIEW

The installation of large patches, as well as the attachment of suitable pad-eyes presents a more complicated problem to the diver than does underwater cutting. Considerable practice is necessary to achieve a consistently good standard of underwater welding for salvage work. As a result, the diver's underwater welding techniques must conform to acceptable standards. Also, the ocean acts as a large heat sink and draws off the heat of the electrode. This may cause blow holes and possible loss of strength between the patch and hull. This is true because the gas cannot escape from the molten pool of metal due to sudden cooling by the surrounding water. Despite the above shortfalls, underwater welds of good strength that are acceptable for salvage work are possible. Unless otherwise specified, the term "underwater welding" as used in this manual refers to the wet welding technique where no mechanical barrier separates the welding arc from the surrounding water.

The two types of welding to be covered in this manual are:

- wet welding and
- dry welding at the "splash zone."

Shielded metal-arc welding is the most widely used process for wet welding. Specific welding procedures for underwater maintenance work on ships is addressed in the *Underwater Ship-Husbandry Manual* (NAVSEA S0600-AA-PRO-010) and the *Naval Ship's Technical Manual, Chapter 074* (NAVSHIPS 59086-AA-STM-010).

Wet welding is accomplished with both the diver and the work completely submerged. The advantages and disadvantages will be discussed in detail in [Chapter 3](#).

Dry welding at the "splash zone" is generally conducted in a dry box or cofferdam at atmospheric pressure. It is essentially conventional welding and is discussed in [Chapter 3](#) to provide the salvor with methods to exclude water from the weld area.

Before proceeding with any cutting or welding procedure described in this manual, all personnel involved must thoroughly review and comprehend the applicable safety

#### 1-2 Change B

## S0300-BB-MAN-010

precautions, warnings and cautions. This information, which is based on knowledge and experience gained through many years of Naval and commercial operations, is presented in [Appendix D](#) and the [Safety Summary](#). Strict adherence to the safety regulations is required. Before starting any new job, a thorough inspection of the situation must be made to determine hazards to personnel, equipment or ship that may exist. Appropriate action must be taken to eliminate or minimize noted hazards.

S0300-BB-MAN-010

---

## CHAPTER 2

---

### UNDERWATER CUTTING

#### WARNING

Serious injury or death may result when adequate precautions are not followed during underwater cutting or welding operations. Supervisors shall ensure that all personnel become thoroughly familiar with the safety precautions covered in [Appendix D](#).

#### WARNING

Under no circumstances shall compressed air be substituted for oxygen in underwater cutting operations due to the danger of contaminating oxygen regulators and hoses with oil residue (hydrocarbons).

#### WARNING

The position of the ground in relation to the diver must be such that at no time does the diver or equipment become positioned between the ground and the electrode. The diver must avoid becoming part of the electrical circuit.

#### 2-1 INTRODUCTION

One of the major tasks of the Salvor is the refloating of stranded vessels and the clearance of navigable harbor areas of wrecks and grounded ships. Most often this requires the use of underwater cutting equipment. This chapter presents detailed technical information and procedures to be used while engaged in underwater cutting operations. As previously mentioned, there are two methods of underwater cutting currently being used: oxygen-arc and shielded metal-arc cutting. Each method is discussed in this chapter.



## S0300-BB-MAN-010

**2-2 OXYGEN-ARC CUTTING**

There are two types of electrodes used for oxygen-arc (oxy-arc) cutting—steel-tubular (manufactured by Arcair) and the exothermic types (Arcair's Sea-Jet and BROCO's Ultrathermic - [see Figure 2-1](#)). These electrodes provide excellent cutting results and can be used with a constant current DC welding generator set on straight polarity (electrode negative) supplying current to the electrode. With the work grounded, the electrode will ignite as it touches the work. Oxygen-Arc is preferred because it cuts plain and low-carbon steel easily.

**WARNING**

AC power shall not be used for underwater cutting and welding due to the extreme danger involved with AC current underwater. Electrical shock produced by AC current prevents voluntary relaxation of the muscles controlling the hand. Consequently, the diver may be unable to let go if his body or equipment accidentally enters the electrical circuit.

**2-2.1 Principles of Operation.** Oxygen-arc cutting is defined as an oxygen cutting process in which metal is severed by means of the chemical reaction of oxygen with the base metal at elevated temperatures. The heat of the arc brings the metal to its kindling temperature, then a high velocity jet of pure oxygen is directed through a tubular cutting electrode at the heated spot. The metal oxidizes and is blown away. The tip of the electrode, which is exposed to both heat and oxidation, is consumed in the process and must be replaced frequently.

**2-2.2 Steel-Tubular Electrodes.** The steel-tubular electrode consists of a steel tube with a waterproofed flux coating which is applied during the manufacturing process. The electrode is 14 inches long with a 5/16-inch outer diameter and a bore diameter of slightly less than 1/8 inch ([see Figures 2-2a and 2-2b](#)).

The waterproof flux coating is similar in composition to the coating on welding electrodes. The flux coating serves the following purposes:

- a. It promotes easy starting and maintenance of the arc.
- b. It liberates gases, thus forming a protective bubble around the arc.

S0300-BB-MAN-010

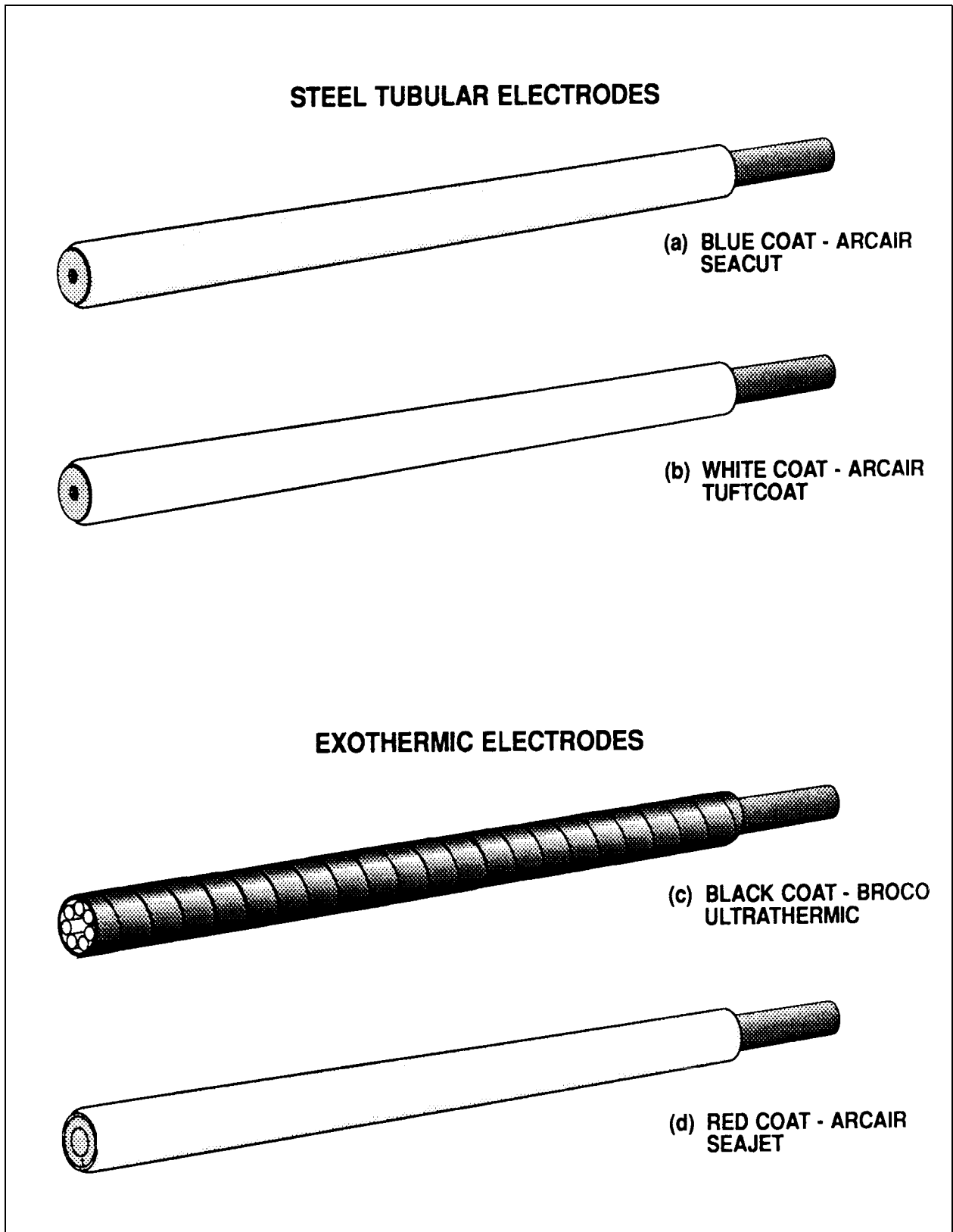

Figure 2-1. Underwater Oxygen-Arc Cutting Electrodes

S0300-BB-MAN-010

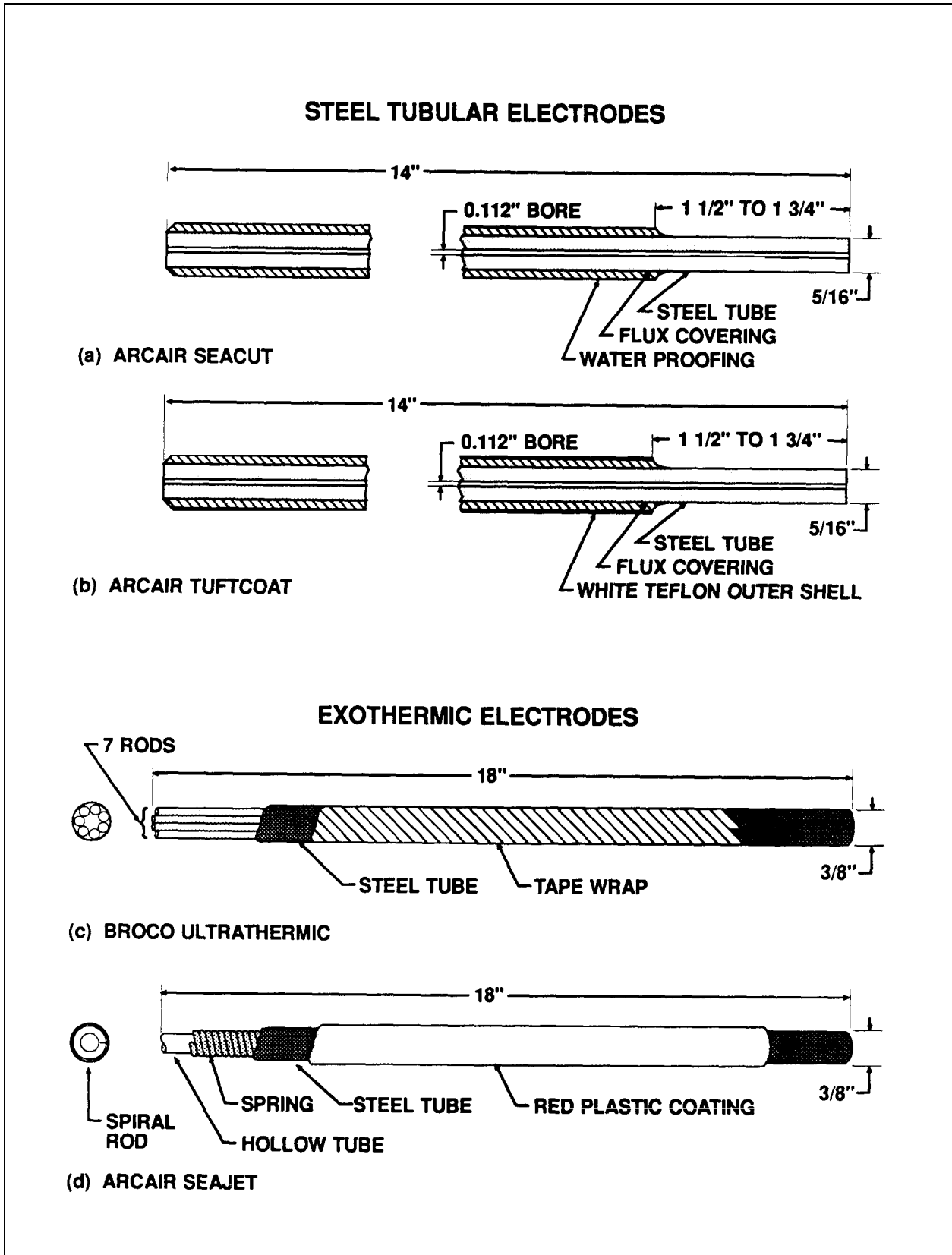

Figure 2-2. Underwater Oxygen-Arc Electrode Designs.

## S0300-BB-MAN-010

- c. It serves as an electrical insulator, even in wet conditions, thereby assisting in safeguarding the diver in the event of accidental body contact while cutting.
- d. It prevents arcing from the side of the electrode when working in confined quarters.

**2-2.2.1 Advantages of the Steel-Tubular Electrodes.** Steel-tubular electrodes have the following advantages:

- a. The cutting technique is simple and readily mastered.
- b. Metals up to 2 inches in thickness can be cut.
- c. Cutting is performed rapidly.
- d. Neat, trim, narrow cuts are produced.
- e. The power required is within the capacity of a 400-ampere welding power supply.
- f. There is less electrode waste because the electrode must be in constant contact with the metal being cut to sustain an arc.

**2-2.2.2 Disadvantages of the Steel-Tubular Electrode.** The disadvantages of the steel-tubular electrode are as follows:

- a. The burning time of the electrode is short (approximately one minute).
- b. It produces a narrow gap which may be difficult to locate in poor visibility conditions.
- c. A welding machine is required.
- d. The higher amperage requirement deteriorates electrode holder more rapidly than the exothermic process.

**2-2.3 Electrode Amperage Requirements.** The electrode amperage requirements for steel-tubular cutting are provided in [Table 2-1](#).

## S0300-BB-MAN-010

**Table 2-1. Cutting Amperage Requirements for Steel-Tubular Electrodes.**

Electrode	Current in Amps
Sea-Cut	300-400
Tuff Cote	300-400

The steel-tubular electrode requires 300-400 amps at the torch working depth. With proper power and oxygen pressure settings, satisfactory cutting results can be obtained. An amperage tong test ammeter is extremely useful in order to determine the exact amperage output of the welding generator. Do not rely solely on the values as indicated by panel control knobs or meters, as these are not always accurate. Simply encircle the welding lead with the tongs of the test ammeter and close them. A clear, accurate reading will instantly register on the scale. The tongs open by a slight pressure of one finger on the trigger and are self-closing. (See Chapter 4, Figure 4-9).

**2-2.4 Oxygen Requirements.** To ensure sufficient oxygen flow to the torch, a high volume, high flow regulator capable of delivering 70 CFM is necessary. A two-stage regulator is recommended. The cutting pressure must be 90 psi over bottom pressure. In Table 2-2, the regulator pressure settings are computed for the various oxygen lengths to a depth of 300 FSW. The formula used to calculate the oxygen values is provided following the table and may be used to determine oxygen requirements for depths and/or hose lengths not in the table.

**2-2.5. Material Consumption.** Table 2-3 is provided for planning purposes. It lists material consumption which can be expected while using steel-tubular electrodes during cutting operations.

**2-2.6 Oxygen Pressure.** Satisfactory cutting may be accomplished using a wide range of oxygen pressure settings; however, supplying less than optimum volume to the torch will decrease cutting efficiency, slow down the operation and unnecessarily fatigue the diver. On the other hand, too much oxygen for a given plate thickness wastes oxygen and increases diver stress by creating excessive back pressure at the electrode tip.

## S0300-BB-MAN-010

**Table 2-2. Oxygen Regulator Settings for Oxygen-Arc Cutting Electrodes  
(Hose Lengths - 50 Feet to 400 Feet)**

<b>Hose length 50 Foot Depth (FSW)</b>	<b>Regulator Pressure Setting (psi)</b>	<b>Hose length 100 Foot Depth (FSW)</b>	<b>Regulator Pressure Setting (psi)</b>
0	95	10	100
10	100	20	104
20	104	30	109
30	108	40	113
40	113	50	118
50	117	60	122
		70	127
		80	131
		90	136
		100	140
			145
<b>Hose length 50 Foot Depth (FSW)</b>	<b>Regulator Pressure Setting (psi)</b>	<b>Hose length 100 Foot Depth (FSW)</b>	<b>Regulator Pressure Setting (psi)</b>
0	105	0	110
10	109	10	114
20	114	20	119
30	118	30	123
40	123	40	128
50	127	50	132
60	132	60	137
70	136	70	141
80	141	80	146
90	145	90	150
100	150	100	155
110	154	110	159
120	158	120	163
130	163	130	168
140	167	140	172
150	172	150	177
		160	181
		170	186
		180	190
		190	195
		200	199

## S0300-BB-MAN-010

**Table 2-2. Oxygen Regulator Settings for Oxygen-Arc Cutting Electrodes  
(Hose Lengths - 50 Feet to 400 Feet) - Continued**

Hose length 250 Foot Depth (FSW)	Regulator Pressure Setting (psi)	Hose length 300 Foot Depth (FSW)	Regulator Pressure Setting (psi)
0	115	10	120
10	119	20	124
20	124	30	129
30	128	40	133
40	133	50	138
50	137	60	142
60	142	70	147
70	146	80	151
80	151	90	156
90	155	100	160
100	160	110	165
110	164	120	169
120	168	130	173
130	173	140	178
140	177	150	182
150	182	160	187
160	186	170	191
170	191	180	196
180	195	190	200
190	200	200	205
200	204	210	209
210	208	220	213
220	217	230	218
230	222	240	222
240	226	250	227
250		260	231
		270	236
		280	240
		290	245
		300	249
			254

## S0300-BB-MAN-010

**Table 2-2. Oxygen Regulator Settings for Oxygen-Arc Cutting Electrodes  
(Hose Lengths - 50 Feet to 400 Feet) - Continued**

Hose length 350 Foot Depth (FSW)	Regulator Pressure Setting (psi)	Hose length 400 Foot Depth (FSW)	Regulator Pressure Setting (psi)
0	125	0	130
10	129	10	134
20	134	20	139
30	138	30	143
40	143	40	148
50	147	50	152
60	152	60	157
70	156	70	161
80	161	80	166
90	165	90	170
100	170	100	175
110	174	110	179
120	178	120	183
130	183	130	188
140	187	140	192
150	192	150	197
160	196	160	201
170	201	170	206
180	205	180	210
190	210	190	215
200	214	200	219
210	218	210	223
220	223	220	228
230	227	230	232
240	232	240	237
250	236	250	241
260	241	260	246
270	245	270	250
280	250	280	255
290	254	290	259
300	259	300	264

Example: To calculate required gauge pressure at any depth, use the following:

For every 10' of oxygen hose, add 1 psi to the 90 psi required at electrode tip. This compensates for frictional line loss. Additionally, add 0.445 psi per foot of depth to compensate for increased hydrostatic pressure.

$$\text{i.e., } \frac{H}{10} + (0.445 \times D) + 90 = \text{Regulator Pressure Setting}$$

Where: H = Hose length (feet) D= Depth FSW 90 = Required psi at electrode tip



S0300-BB-MAN-010

**Table 2-3. Material Consumption using Steel-Tubular Electrodes**

Unit	Steel Plate cut in ft/box of electrodes			
	1/4-in. plate	1/2-in. plate	3/4-in. plate	1-in. plate
50-lb. Box of electrodes <sup>1</sup>	240	170	170	160
Oxygen cu.ft. per box of electrodes <sup>2</sup>	594	440	440	440

1. Each 50-pound box contains approximately 167 electrodes.

2. There are approximately 220 cubic feet of gas in a standard oxygen cylinder charged to 2000 psi.

## S0300-BB-MAN-010

**2-2.7 Oxygen Purity.** The oxygen purity for all underwater oxygen cutting should be 99.5 percent or greater. As the oxygen purity is reduced, so is the cutting efficiency. A one percent decrease in oxygen purity will result with a 25 percent reduction in cutting speed. In addition, the quality of the cut decreases and the amount of slag adherence increases. At oxygen purities of 95 percent or less, the operation becomes one of melting and washing out rather than cutting. Commercially available oxygen specifically for cutting should be 99.9 percent pure.

**2-2.8 Grounding the Work.** Before conducting any type of electric arc cutting or welding, a ground cable must be attached to the work piece. The diver can either leave the surface with the cutting torch, ground cable and cutting electrodes or they can be lowered after arrival at the work site. The first task is to clean a spot for the ground clamp. The spot should be in a position in front of the diver and should be scraped or wire brushed shiny clean. For diver safety, only C-type clamps should be used as grounding clamps for underwater cutting or welding operations. The clamp must be firmly secured to the work piece and the cable should have sufficient slack to prevent it from being pulled loose. The diver may elect to lightly tack weld the clamp in place when there is a possibility of it working loose. From time to time as the cut progresses, the diver may have to reposition the ground clamp to avoid becoming part of the electrical circuit.

**NOTE**

Clean metal cuts better than corroded or growth-encrusted metal. Steel covered with ordinary mill scale and one or two thin coats of paint may be cut easily. Thick scale, thick paint, barnacles and similar marine growth make cutting difficult and should be removed. An ordinary paint scraper is useful in removing light scale and paint; however, for heavier growths, a high-pressure water jet cleaning tool may perform the cleaning process satisfactorily. If possible, it is important to clean both sides of the metal before cutting. Obstructions on the opposite side of the metal will clog the cut and prevent the cutting jet from blowing through. If inaccessible, striking the area to be cut with a heavy sledge hammer may sufficiently loosen scale on the opposite side.

**2-2.9 Steel-Tubular Electrode Cutting Technique (Thick plate).** When cutting steel plate that is 1/4-inch thick or greater, use the drag technique (see [Figure 2-3](#)) and proceed as follows:

## S0300-BB-MAN-010

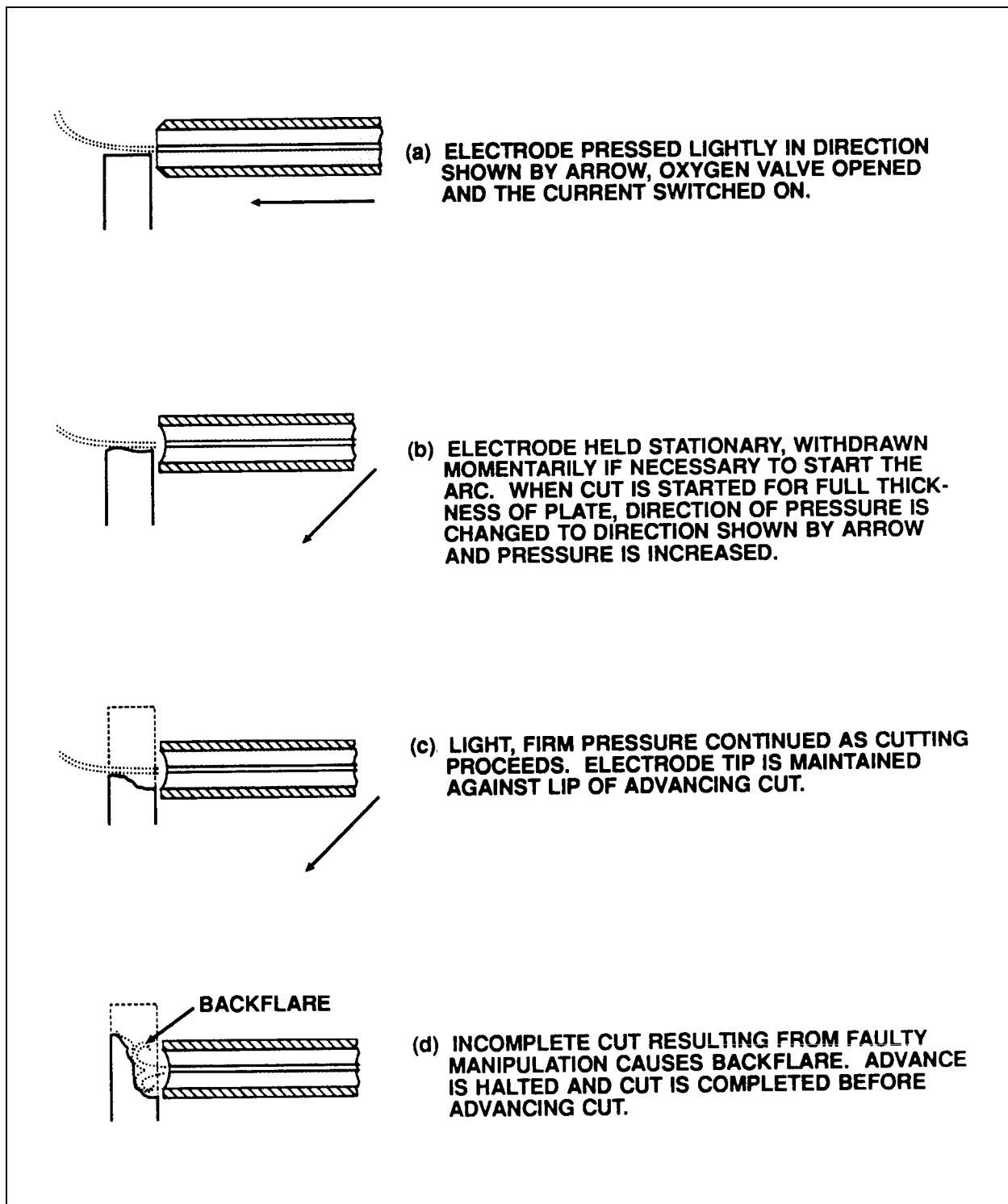

Figure 2-3. Drag Techniques for Cutting Steel with Steel-Tubular Electrodes

## S0300-BB-MAN-010

- a. Insert the electrode into the collet opening until it bottoms out against the washer. Tighten the collet nut. To start the cut, hold the electrode perpendicular to the surface to be cut and hold the oxygen trigger down to get a steady flow. Place the tip of the electrode against the work and call for SWITCH ON. If necessary, withdraw the electrode slightly and tap it against the work to start the arc.

### NOTE

Thick, gauntlet-type rubber gloves in good condition, worn over a pair of playtex-type gloves afford the best protection against electrical shock. They should be secured at the wrist to prevent slag from entering the glove. In cold water, wet-suit gloves in good condition, worn over surgical gloves are equally effective.

- b. As soon as the cut is started through the full thickness of the plate, drag the electrode along the desired line of cut and keep it perpendicular to the work. Hold the electrode with the free hand as if holding a pool cue, approximately Four inches from the tip for a more stable cut. The tip of the electrode should be pressed against the advancing lip of the cut. Pressure should be exerted in two directions: inward to compensate for electrode burn-off and forward to advance the cut.

S0300-BB-MAN-010

**CAUTION**

The hand should never be closer than 4 inches from the electrode tip. Therefore, as the electrode is consumed and becomes manageable, the pool que grip can be released.

**NOTE**

Before beginning the cut, the diver should visually check the oxygen flow while holding the electrode in a horizontal position. Holding the oxygen for approximately 20 seconds allows time for enough cutting-gas pressure to build up along the full length of the hose. To ensure a clean cut, at least a 6-inch stream of oxygen should be issued from the electrode tip.

- c. Low oxygen pressure, high travel speed and uncontrolled manipulation are typical causes of back-flare that result in incomplete cuts (see [Figure 2-3d](#)). In such cases, the area must be chipped and cleaned and the cut restarted.

**WARNING**

When the electrode has been consumed to within 3 inches of the torch, stop the cut and signal for SWITCH OFF before attempting to change electrodes. Maintain the torch in the cutting position until the tender (phone talker) acknowledges SWITCH OFF. Then tap the electrode twice to make sure the current is off. This safety precaution is mandatory, regardless of the type of electrode being used.

- d. When the electrode has burned down to within 3 inches of the collet nut, break the arc, release the oxygen trigger and call for SWITCH OFF. When the phone talker has confirmed SWITCH OFF, tap the electrode twice to make sure the switch is off. Loosen the collet nut 1/2-turn and blow the cutting stub from the torch by squeezing the trigger. Insert a new electrode and repeat the starting procedure.

## S0300-BB-MAN-010

**2-2.10 Steel-Tubular Electrode Cutting Technique (Thin plate).** When cutting steel plate which is 1/4-inch thick or less, use the following technique. This technique is slightly different from that used on thick plate.

- a. Instead of maintaining the electrode tip in the cut and pressing against the lip of the advancing cut, the tip should barely touch the plate surface as it advances along the line of cut. (See the technique illustrated in Figure 2-4.)
- b. When visibility is poor, an alternate technique can be used. Hold the electrode perpendicular to the plate until the cut is started through the full thickness. Then, angled at approximately 45° to the plate and in the direction of the cut, proceed as if cutting a thicker plate. The effective thickness of the plate is increased and normal pressure can be applied to the electrode. (See alternate technique, Figure 2-4.)

**CAUTION**

Pushing the electrode into the hole too fast will result in a shower of spatter, which may damage the diving equipment and/or result in a blow-back.

**2-2.11 Piercing Holes in Steel Plate.** Holes can be easily pierced in steel plate using steel-tubular electrodes. The following technique is recommended:

- a. Touch the plate lightly with the electrode at the desired point. Hold the oxygen trigger down and call for SWITCH ON.
- b. Hold the electrode stationary for a moment, withdrawing it momentarily as necessary to start an arc and permit melting of the steel tube inside the covering.
- c. Push the electrode slowly into the hole until the plate is pierced.

This technique has been used to pierce holes in 3-inch steel plate without difficulty (see Figure 2-5). A hole slightly larger than the electrode will be produced. The hole can be enlarged by working the electrode in and out in a sawing motion. A similar technique may be used with exothermic electrodes.

## S0300-BB-MAN-010

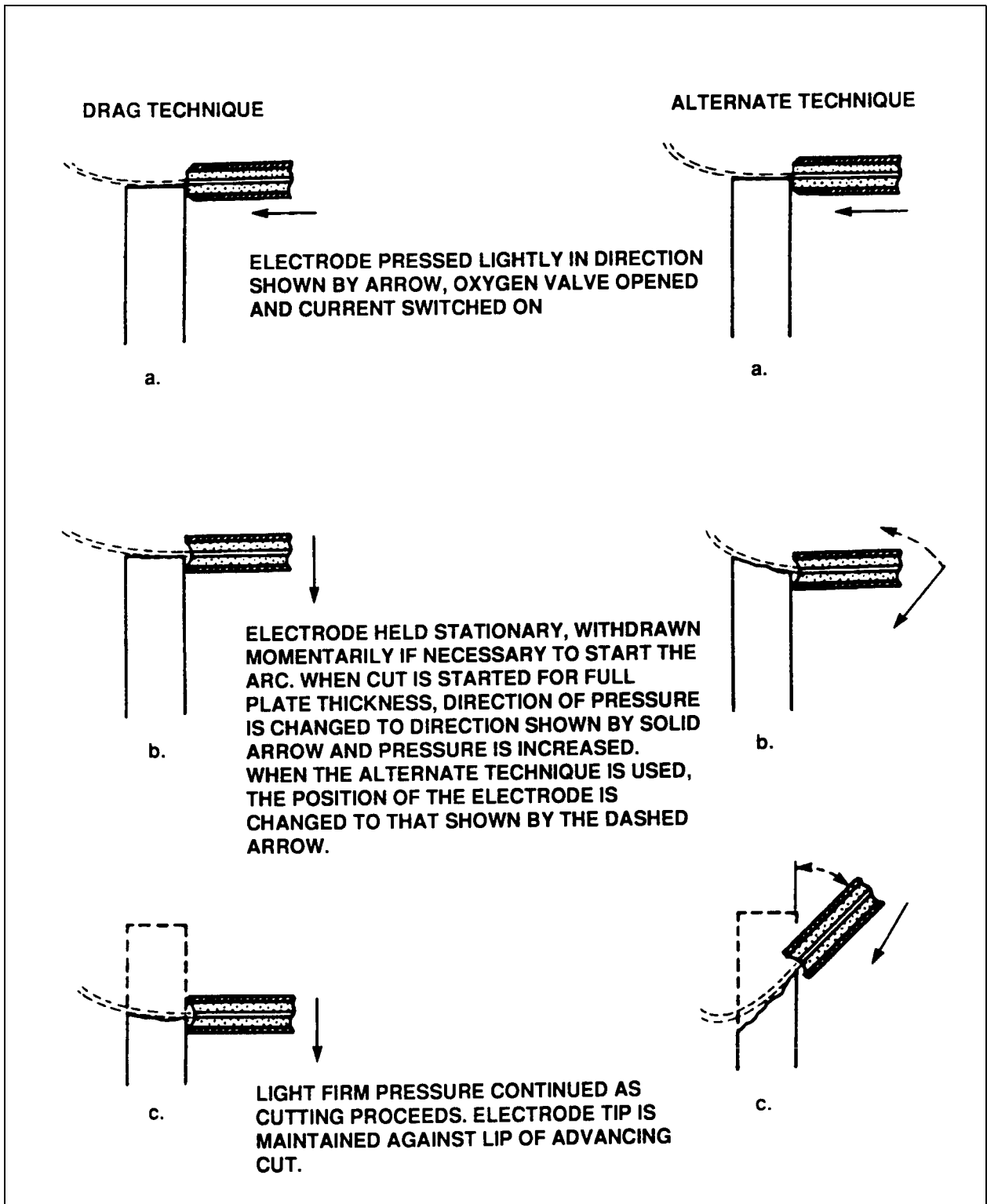

Figure 2-4. Technique for Cutting Steel Less Than 1/4 Inch with Steel-Tubular Electrodes.

S0300-BB-MAN-010

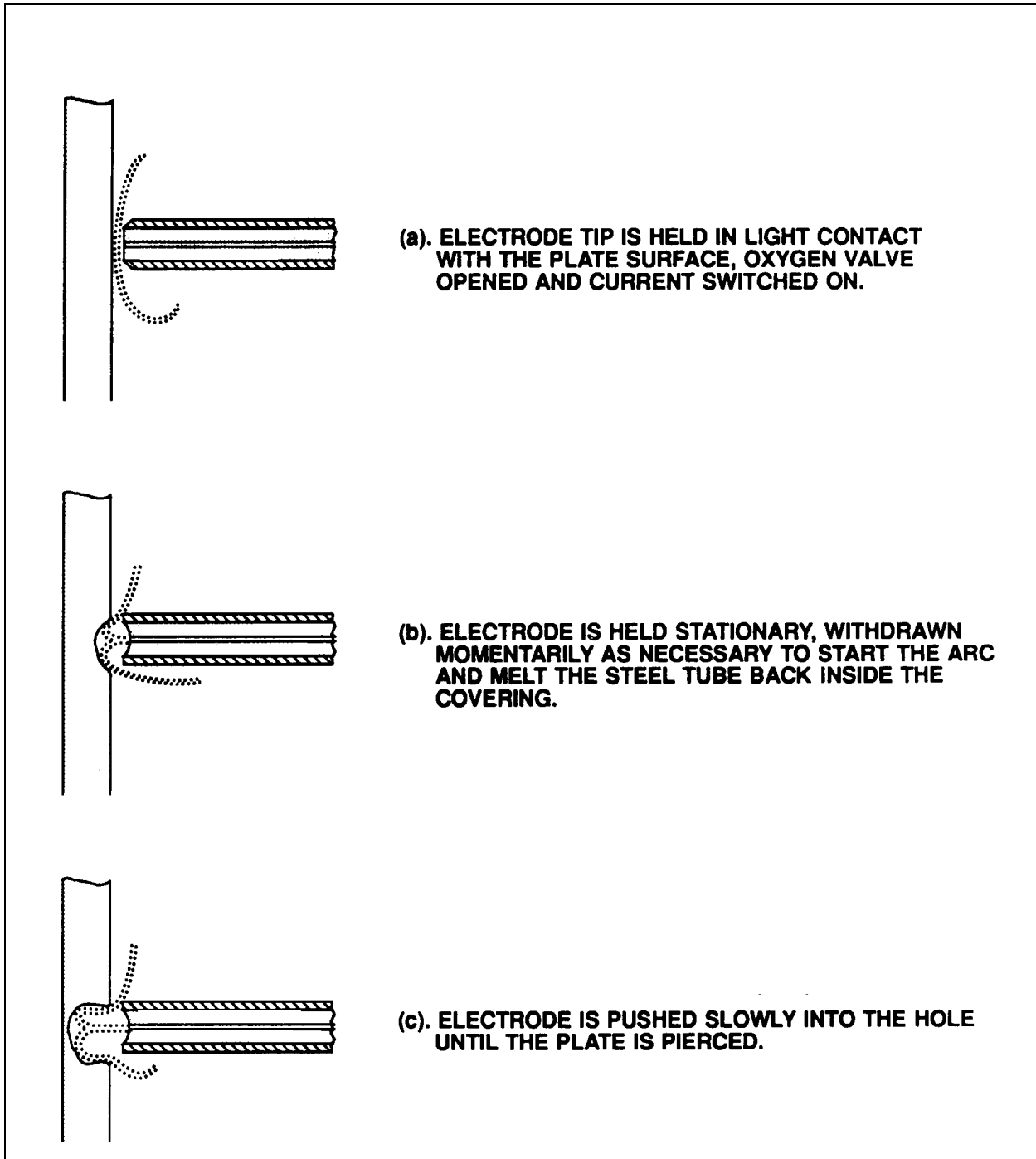

Figure 2-5. Technique for Piercing Holes in Steel Plate using the Oxy-Arc Process with Steel Tubular Electrodes.



## S0300-BB-MAN-010

**2-2.12 Steel-Tubular Electrode Cutting Technique (cast iron and non-ferrous metals).** Cast iron and non-ferrous metals do not oxidize; therefore, underwater cutting essentially becomes a melting process. There is no chemical reaction of the oxygen and the base metal. Therefore, the only benefit realized by the oxygen is the mechanical effect of blowing the molten metal away.

Since the melting process takes place only in the immediate vicinity of the arc, the following procedure is recommended:

- a. Using a sawing motion, manipulate the electrode in and out of the cut.
- b. For thin plates, electrode manipulation is not necessary since the procedure is virtually the same as when cutting thin, ferrous metal.
- c. Maximum current (up to 500 amperes if available and provided the safety switch is rated to carry such a load) is recommended since the cutting is dependent upon the melting action of the arc.

**WARNING**

Hydrocarbons ignite almost spontaneously in the presence of oxygen. Never allow oxygen-carrying components to come in contact with oil or grease.

**2-2.13 Post-dive Maintenance.** After each use, rinse the torch in fresh water and dry it. Disassemble and inspect the flashback arrestor for corrosion damage due to electrolysis or clogging. (Frequent clogging or screen burn-out indicates either insufficient oxygen pressure or burning the electrode shorter than the 3-inch minimum.) Replace any damaged parts (see [Figure 2-6a, b or c](#) as applicable). All equipment should be thoroughly dry before storing. Secure hose ends with caps or tape to keep out debris. Store all equipment, including electrodes, in an oil-free environment. Electrodes which have been exposed to salt water will rust. They should be rinsed with fresh water, blown dry and stored separately to prevent damage to other rods.

S0300-BB-MAN-010

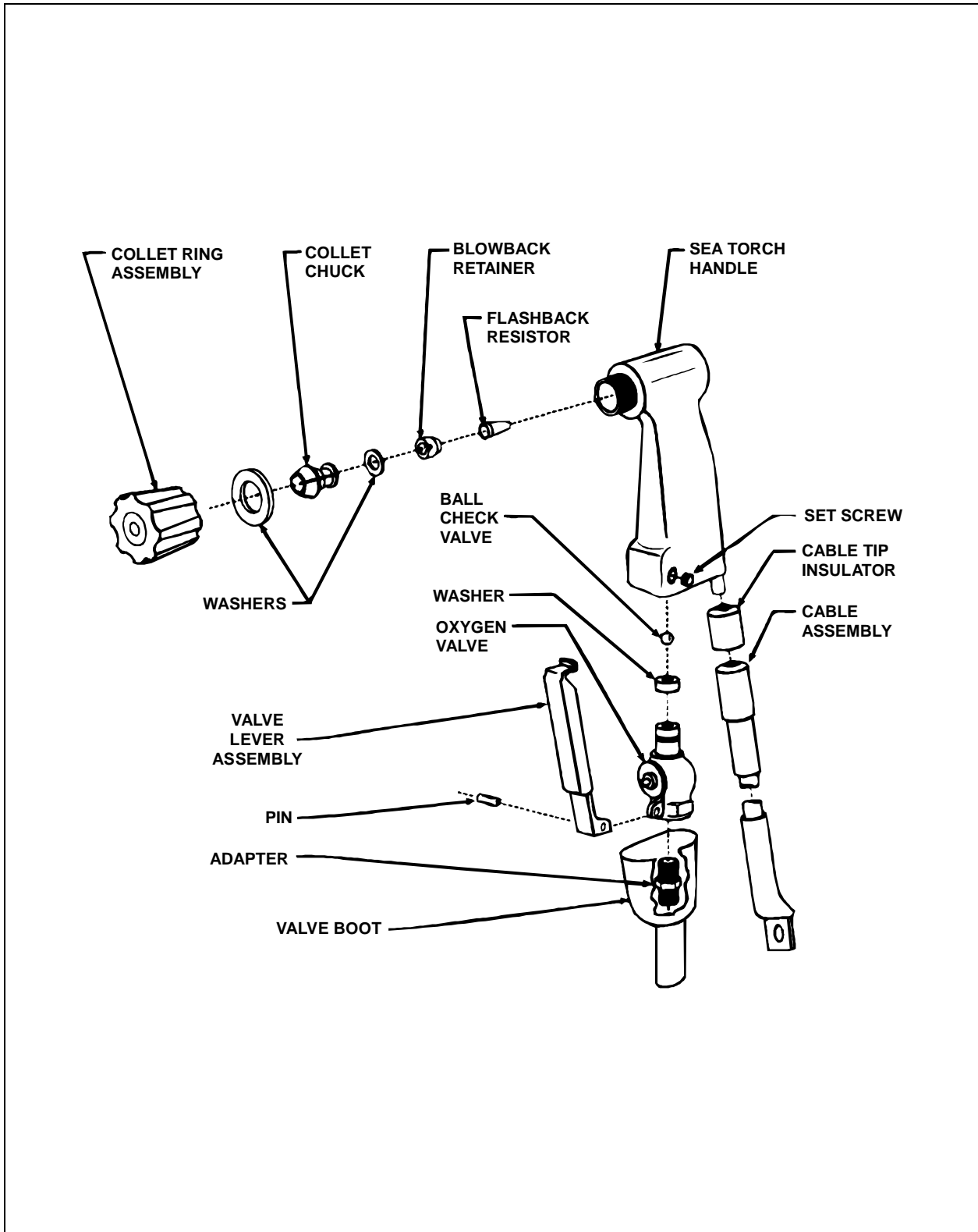

Figure 2-6a. Underwater Oxygen-Arc Cutting Torch Breakdown (Arcair).

S0300-BB-MAN-010

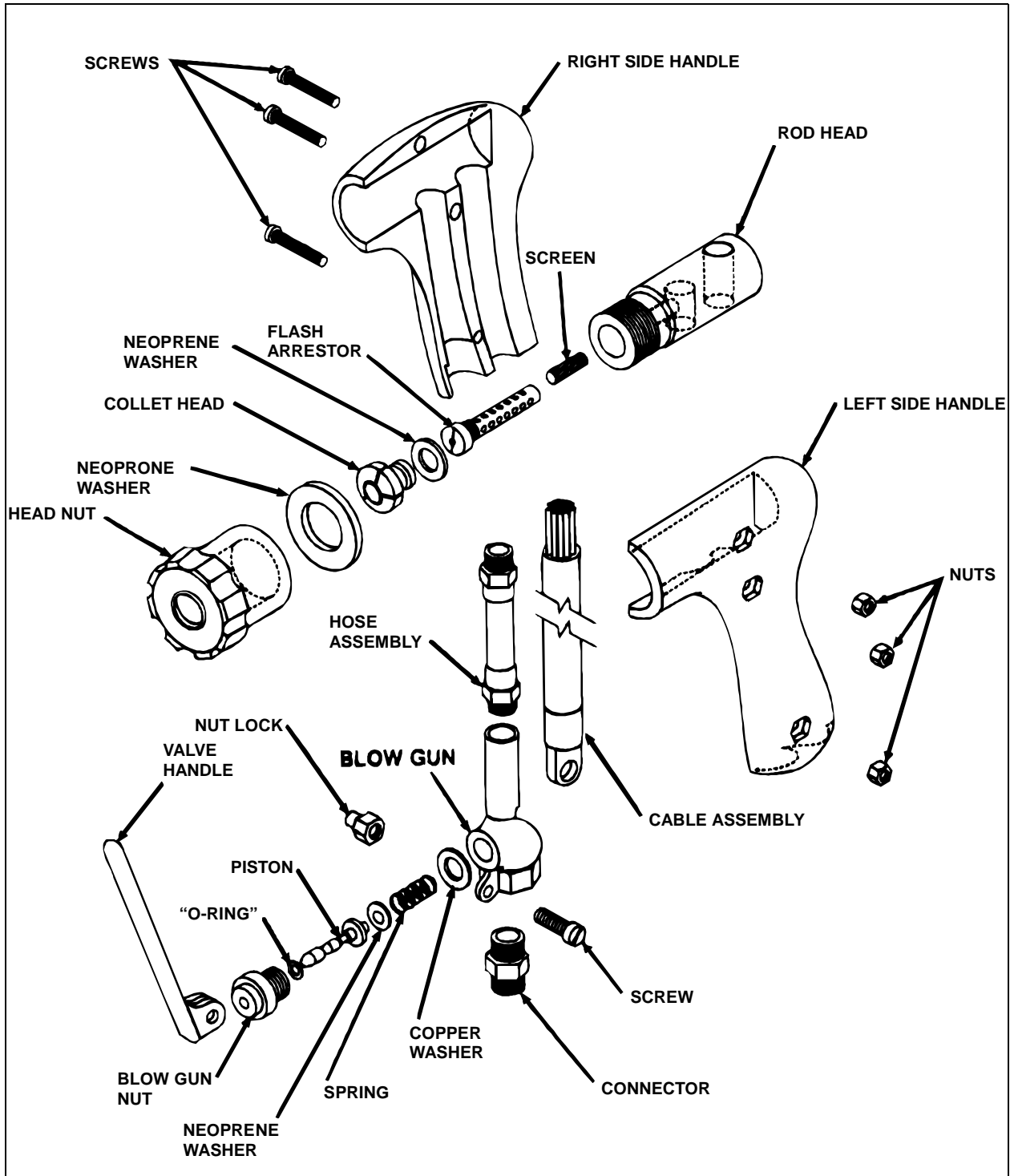

Figure 2-6b. Underwater Oxygen-Arc Cutting Torch Breakdown (BROCO).

S0300-BB-MAN-010

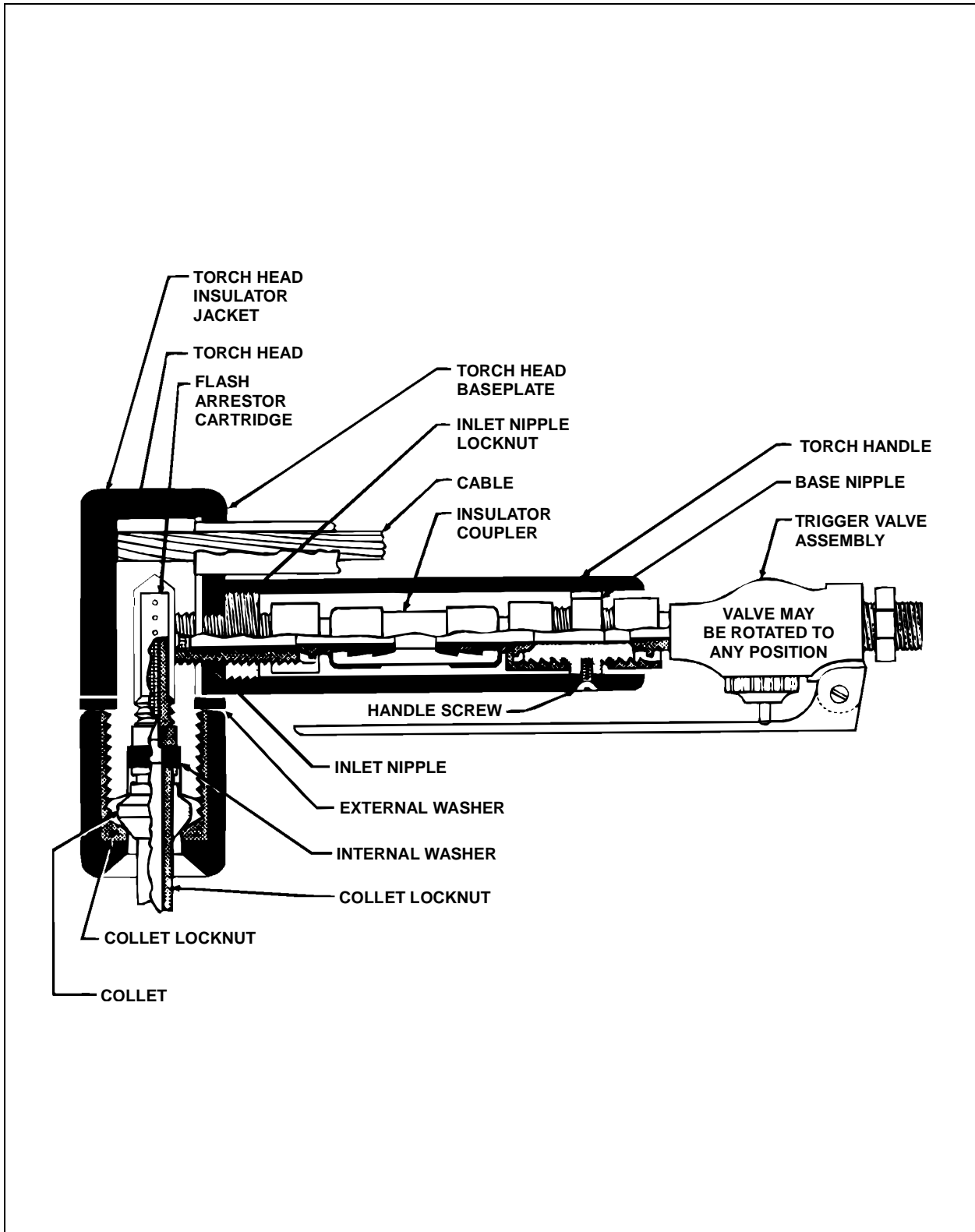

Figure 2-6c. Underwater Oxygen-ARC Cutting Torch Breakdown (Craftsweld).

## S0300-BB-MAN-010

**2-3 EXOTHERMIC ELECTRODES****WARNING**

It is not safe to operate the torch without the flashback arrestor installed. To do so may cause injury and/or destroy the torch.

**CAUTION**

It is important that the proper washer-collet combination is used. An oversize washer will allow the electrode to bottom on the flashback arrestor, creating electrolysis and possible arcing. An undersize washer will restrict the flow of oxygen to the larger bore electrodes, causing inefficient cutting.

The BROCO Ultrathermic electrode consists of seven small rods inside a thin steel tube (see [Figure 2-2c](#)). One of the seven rods is a special alloy that will burn independently after an arc is struck and oxygen is flowing through the tube. The remaining six rods are made of mild steel. The electrode is insulated with electrical tape. The 3/8-inch electrode is 18 or 36 inches long; the 1/4-inch comes only in 18-inch lengths. It will fit Arcair's Sea Torch, BROCO's BR-22 Underwater Cutting Torch and Craftsweld's Arc-Oxygen Cutting Torch by using the proper collet and washer combinations. The ultrathermic electrode will melt almost any material with its 10,000°F plus, tip heat.

The Arcair Sea-Jet cutting electrode consists of a thin mild steel tube enclosed in a spiral, mild steel spring-like wrapping, which is encased in a larger metal tube (see [Figure 2-2d](#)). The electrode is coated with waterproofing and insulating material. Like the Ultrathermic, the Sea-Jet will burn ferrous and non-ferrous materials such as concrete, rock, barnacles and other sea growth. The electrode is 3/8-inch in diameter and 18 inches long. It will also fit the Arcair, BROCO and the Craftsweld Torch.

When using the Ultrathermic or Sea-Jet cutting electrodes, an adapter kit will be necessary in order to achieve proper fit of the electrodes. The kits consist of a variety of collets and washers designed to adapt the torch for the standard 3/8- and 1/4-inch electrodes. Smaller adapters are available for other cutting or welding operations.

**2-3.1 ELECTRODE AMPERAGE REQUIREMENTS.** The exothermic electrodes will sustain ignition without electrical power as long as oxygen is flowing; therefore, the diver may call for SWITCH OFF once the electrode is burning. Although the exothermic

## S0300-BB-MAN-010

electrodes will continue to burn when the current is off, it is recommended that electrical current be used to provide more heat and enhance the cutting process on all conductive material.

[Table 2-4](#) lists recommended current settings for various cable lengths and sizes.

**NOTE**

The Sea-Jet electrode will operate on a wide range of amperage settings up to 400 amps. A 12-volt DC battery may be used for start up power and satisfactory cutting can be performed without power, however, the use of 200-300 amps will produce optimum cutting results. (Manufacturer's recommendations)

Correct power settings will result in quick, efficient cutting. The ultrathermic electrode requires only 150 amps at the torch working depth, as opposed to 200-300 for the Sea-Jet. Excessive current settings for the ultrathermic will result in rapid consumption of the electrode. With proper oxygen and power settings, the exothermic electrodes will burn for 45 to 55 seconds. A tong test ammeter is extremely useful in determining the exact amperage being used at the workpiece. Do not rely solely on the values as indicated by panel control knobs or meters, as these are not always accurate. Simply encircle the negative (-) welding lead with the tongs of the amperage tong meter and close them. A clear, accurate reading is instantly registered on the scale. The tongs open by a slight pressure of one finger on the trigger and are self-closing. (see [Chapter 4, Figure 4-9](#)).

S0300-BB-MAN-010

**Table 2-4. Recommended Power Settings for Cable Length/Size  
for Ultrathermic Electrodes<sup>1</sup>**

Length (Feet)	Amperage Setting for Cable Size Used	
	1/0	2/0
150	155	152
200	157	154
250	159	156
300	161	158
350	163	160
400	165	162
450	167	164
500	169	166

1. For greater cable lengths, add 2 amperes for each additional 50-foot length of power cable. (Based on manufacturer's data)

## S0300-BB-MAN-010

**2-3.2 Oxygen Requirements.** Exothermic cutting consumes a large volume of oxygen; therefore, a 3/8-inch inside diameter oxygen hose is required to maintain sufficient volume. **The hose size is important because it is the oxygen volume together with heat that does the cutting while the pressure blows the slag away.** A high volume, high flow regulator capable of delivering 70 CFM is necessary. A two-stage regulator is recommended. The cutting pressure must be 90 psi over bottom pressure (see Table 2-2).

**2-3.3 Material Consumption.** Table 2-5 is provided for planning purposes. It lists an approximate range of cut through various plate thicknesses. It is expected that actual lengths of cut will fall within the range of cut figures listed, as these figures were attained under actual field conditions. Allowances should be made for diver proficiency and underwater conditions such as visibility, metal cleanliness and current.

**2-3.4 Advantages and Disadvantages of The Exothermic Electrode Cutting Process.** Exothermic electrodes have the following advantages:

- a. The cutting technique is very simple and readily mastered.
- b. They will cut thin metal when the power is off.
- c. Cutting is performed rapidly.
- d. They will cut all ferrous and non-ferrous metals.
- e. They are applicable to all metal thicknesses.
- f. They will burn through concrete, rock, coral, marine growth and other non-conductive materials when the power is off.
- g. The power required is within the capability of a 200-ampere welding power source.
- h. A 12-volt battery can be used as an ignition source.

**CAUTION**

Unlike steel-tubular rods that stop burning the instant the electrical circuit is broken, the exothermic electrodes will continue to burn as long as oxygen is flowing through the electrode.



S0300-BB-MAN-010

**Table 2-5. Exothermic Electrode Consumption Guide**

<b>Electrode diameter</b>	<b>Plate Thickness</b>	<b>Range of cut per electrode<sup>1</sup></b>
1/4-in.	1/4-in.	20-25-ins.
	1/2-in.	10-15-ins.
3/8-in.	1/2-in.	12-20-ins.
	1-in.	9-14-ins.
	1 1/2-ins.	8-12-ins.

1. Range of cut figures represent cuts made with and without power. The lower numbers were attained without power and the higher numbers with power. Obviously, a 20 percent increase in cutting rates can be realized by using power as apposed to allowing the electrode to burn independently.

## S0300-BB-MAN-010

**2-3.4.1 Disadvantages of Exothermic Electrodes.** The following are disadvantages of exothermic electrodes.

- a. Larger volume of oxygen is required than with steel-tubular electrodes.
- b. Burning time of the electrode is short; 45 to 55 seconds.
- c. Contact with the work is not required to sustain ignition, thus electrode waste can occur.

**WARNING**

The position of the ground in relation to the diver must be such that at no time does the diver or the equipment get between the ground and the electrode. The diver must avoid becoming part of the electrical circuit.

**CAUTION**

When the electrode burns down to within 3 inches of the torch, call for SWITCH OFF. Release the trigger to extinguish the electrode, since it will continue to burn when the electrical power is off with oxygen still flowing. Do NOT attempt to use the last 3 inches of the electrode. To do so will subject the torch to unnecessary heat and possible damage.

**2-3.5 Grounding the Work.** Before conducting electric-arc cutting on conductive material, a ground cable must be attached to the work piece. The diver can either leave the surface with the cutting torch, ground cable and cutting electrodes or they can be lowered after arrival at the work site. The first task is to clean a spot for the ground clamp. The spot should be a position in front of the diver and should be scraped or wire brushed shiny clean. For diver safety, only C-type clamps are to be used as grounding clamps for underwater cutting or welding operations. The clamp must be firmly secured to the work piece and the cable should have sufficient slack to prevent the clamp from being pulled loose. The diver may elect to lightly tack weld the clamp in place where there is a possibility of it working loose. From time to time as the cut progresses, the diver may have to reposition the ground clamp to avoid becoming a part of the electrical circuit.

## S0300-BB-MAN-010

**NOTE**

Thick, gauntlet-type rubber gloves in good condition, worn over a pair of playtex-type gloves afford the best protection against electrical shock. They should be secured at the wrist to prevent slag from getting inside the glove. When working in cold water, wetsuit gloves in good condition, worn over surgical gloves are equally effective.

**NOTE**

A striker plate attached to the positive (+) clamp is a good idea for a starting point for rod ignition. The burning rod can then be used to clear off any marine growth, making a place for the ground clamp.

**2-3.6 Exothermic Cutting Technique.** The 1/4-inch electrode may be used to cut steel up to 1/2-inch in thickness. The 1/4-inch electrode leaves a narrow kerf and is preferable for fine cutting. When visibility is poor or when cutting heavier steel, the 3/8-inch electrode is more efficient. The following techniques are recommended:

- a. Insert the electrode into the collet opening until it bottoms out on the washer. Tighten the collet nut. When ready to start the cut, hold the oxygen trigger down to get a steady flow of oxygen. Release the trigger slightly. Hold the electrode at an angle of 45° to 90° to the surface to be cut, depending on material thickness (see [Figure 2-7](#)). Call for SWITCH ON. Draw the tip of the electrode across the work and strike an arc. As soon as the arc is established, squeeze the trigger full open. Hold the tip of the electrode in the molten pool and drag the electrode along the line of cut. Apply a downward pressure until the electrode penetrates the full thickness of the material to be cut.

**NOTE**

Before beginning the cut, the diver should visually check the oxygen flow while holding the electrode in a horizontal position. Holding the oxygen trigger down for approximately 20 seconds allows time enough for cutting-gas pressure to build up along the full length of the hose. To ensure a clean cut, a 6-inch (minimum) oxygen emission should be maintained at the electrode tip.

S0300-BB-MAN-010

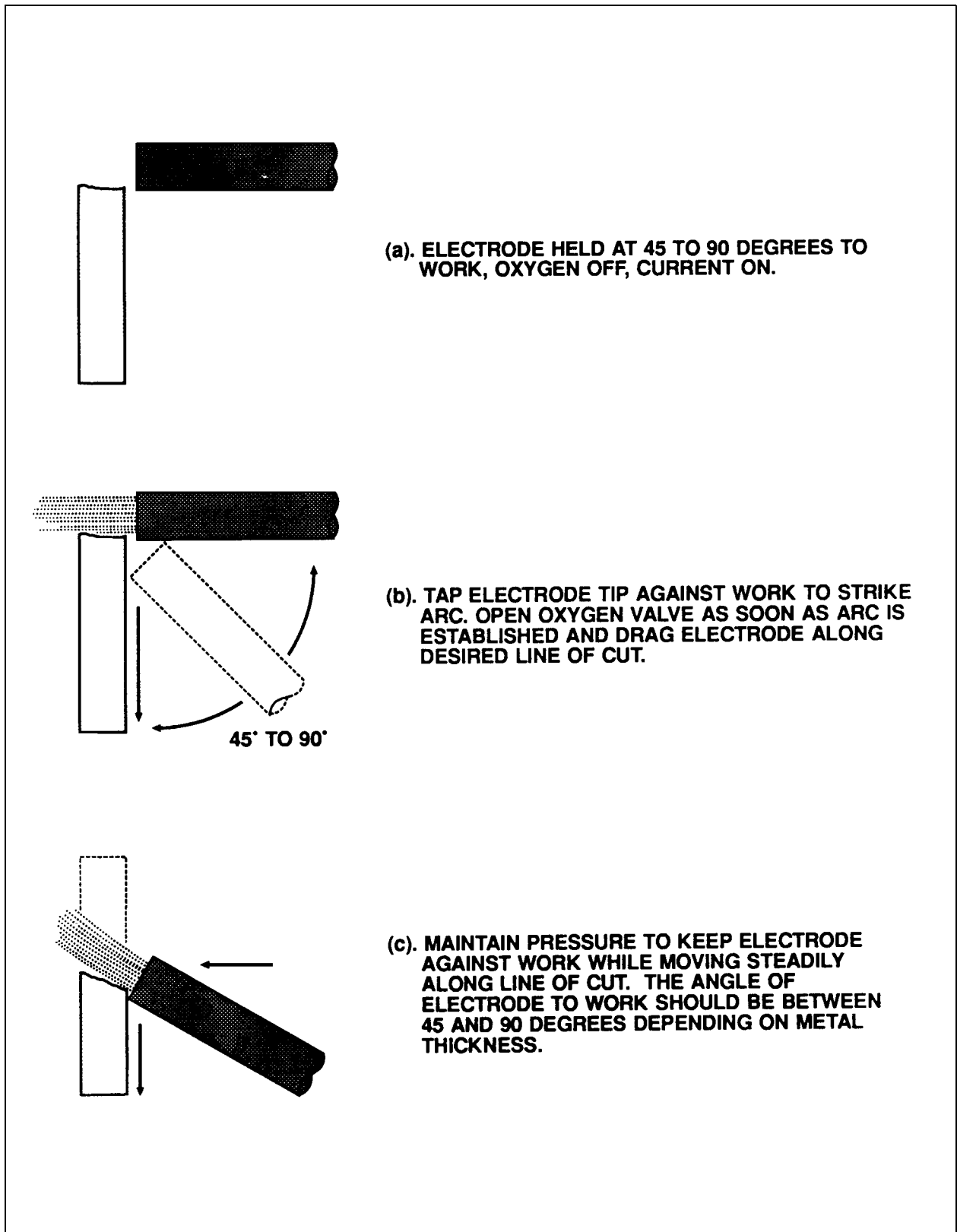

Figure 2-7. Technique for Cutting Steel Using Exothermic Electrode.

## S0300-BB-MAN-010

- b. To advance the cut, apply slight pressure to maintain electrode/work contact. Hold the electrode with the free hand as if holding a pool cue, approximately 4 inches from the tip for a more stable cut. Move slowly at first, maintaining full penetration. Lack of penetration will be evident by back-spray, increased cutting noise and slag build-up. In such cases, stop advancement and go back and wash out all hangers to complete the cut. It is important to keep the electrode against the work while cutting and keep the tip of the electrode in the puddle. Do NOT try to hold an arc.

**CAUTION**

Burning the electrode shorter than the 3-inch minimum can damage the torch interior.

- c. When the electrode has burned down to within 3 inches of the collet nut, break the contact, release the oxygen trigger and call for SWITCH OFF. When the phone talker has confirmed SWITCH OFF, tap the electrode twice to make sure the switch is off. Loosen the collet nut 1/2-turn and blow the cutting stub from the torch by squeezing the trigger. Insert a new electrode and repeat the starting procedure outlined in 2-3.6a. above.
- d. For cutting material thicker than 1/2-inch, use a 3/8-inch electrode. A sawing motion often works well on thicker materials.
- e. For materials several inches thick, a saw and wedge cutting technique similar to chopping a tree with an axe may be necessary to widen the cutting path.

**2-3.6.1 Exothermic Cutting Technique (Cast Iron, Stainless Steel and Non-Ferrous Metals).**

Cast iron, stainless steel and non-ferrous metals do not oxidize; therefore, underwater cutting becomes a melting process. The exothermic process develops tip-temperatures in excess of 10,000 °F, which is sufficient to melt these materials with ease. The following technique is recommended:

- a. Keep the tip firmly buried in the puddle. Using a sawing motion, manipulate the electrode in and out of the cut.

## S0300-BB-MAN-010

- b. To cut thick, non-ferrous metals, create a puddle and keep the electrode tip slightly below the surface of the molten metal. Every few seconds, push the cutting electrode deeper into the molten pool to wash out and blow the molten metal through. Increase the oxygen pressure at the electrode tip to 110 psi for metals over 3 inches in thickness (see Table 2-2).

**2-3.6.2 Exothermic Cutting Technique (Concrete, Rock and other Non-Conductive Materials).** When cutting non-conductive materials, a striker plate attached to the ground cable is necessary to strike an arc. The striker plate is placed next to the material to be cut. Call for SWITCH ON, squeeze the trigger slightly, drag the electrode across the striker plate and the electrode will ignite. Once the electrode is ignited, maintain the oxygen flow. Call for SWITCH OFF. If electrode ignition is lost, reignite it from the striker plate by repeating the procedure. Each subsequent electrode must be ignited from the striker plate in the same manner. The following procedure is recommended:

- a. For best results, use the 3/8-inch electrode. Ignite the electrode with a striker plate.
- b. Press the tip into the material to create a molten pool. As the material melts, periodically move the electrode in and out to allow the oxygen to blow the molten material away.

**WARNING**

Never get between the electrode holder and the striker plate (ground) when the switch is on.

**2-3.6.3 Exothermic Hole Piercing.** Exothermic electrodes can be used to pierce holes in plate using the same technique as described for steel-tubular electrode.

**2-3.7 Trouble Shooting.** Oxy-arc, especially exothermic cutting relies on an unobstructed oxygen flow to be most effective. With inadequate oxygen flow, the rod will burn but not produce the desired cutting effect. Since the actual cutting result is derived from the volume of oxygen reaching the target, any restriction in oxygen flow will decrease efficiency.

**2-3.7.1 Symptoms.** The following are indications of an oxygen-delivery problem:

- a. Oxygen jet at electrode tip less than 6 inches.

## S0300-BB-MAN-010

- b. Electrode burns down in approximately 60 seconds of continuous use and cuts less than 12 inches of 1/2-inch plate.

**2-3.7.2 Probable causes.** The following are possible causes to an oxygen flow problem:

- a. Regulator incapable of delivering 70 cfm.
- b. Torch incapable of delivering sufficient flow. Older torches; those designed for 5/16-inch electrodes will not flow sufficient oxygen volume.
- c. Torch obstruction, such as dirt in oxygen passage, a damaged flashback arrestor, clogged or burnt monel screen or a damaged oxygen flow valve.
- d. Oxygen hose too small, using 1/4- or 5/16-inch hose or a clogged or obstructed 3/8-inch hose.

In all the above cases the regulator pressure will appear normal. There simply is not enough oxygen volume to allow the electrode to cut properly.

**WARNING**

Do not operate the torch with the flashback arrestor removed. To do so may cause injury and/or destroy the torch.

**2-3.7.3 Locating and solving the problem.** The following steps will likely isolate the problem:

- a. Shut off electrical power to the torch.
- b. Remove electrode from torch and blow through electrode to check passage.
- c. Disconnect the oxygen supply line at the torch handle and flow oxygen through the hose. If the flow rate is weak the problem is likely a faulty regulator or a clogged hose. Check each independently and clean, repair or replace as necessary. If the flow rate is strong at the hose end then:
- d. Check the torch collet washer to ensure it is in proper position, that it is the correct one for the electrode being used and that it is not obstructing the oxygen passage.

## S0300-BB-MAN-010

**NOTE**

Washers for 5/16-inch electrodes and smaller will significantly obstruct the oxygen flow.

- e. Remove flashback arrestor and monel screen from torch and inspect. Replace as necessary. Blow oxygen through the valve and torch to ensure a clear passage.

This should complete the checkout of a low flow problem. Reassemble and recheck to ensure that the problem has been solved.

**2-3.8 Post-Dive Maintenance.** After each use, rinse the torch in fresh water and dry it. Disassemble and inspect the flashback arrestor and monel screen for corrosion damage due to electrolysis or clogging. Frequent clogging or screen burn-out indicates either insufficient oxygen pressure or burning the electrode shorter than the minimum 3-inch remainder. Replace any damaged parts (see [Figure 2-6a](#), [b](#) or [c](#) as applicable). All equipment should be thoroughly dry before storing. Secure hose ends with caps or tape to keep out debris. Store all equipment in an oil-free environment. Electrodes which have been exposed to salt water will rust. They should be rinsed with fresh water, blown dry and stored separately to prevent damage to other rods.

**2-4 SEELER ENTERPRISES LU-001 EXOTHERMIC CUTTING TOOL (KERIE CABLE) |****WARNING**

Do NOT attempt to speed up the cutting by creating a fire or inferno deep inside the metal. Such a situation can lead to an explosion.

**WARNING**

The Kerie Cable WILL NOT cut rock or concrete either above or below water. To attempt to do so may create an explosion causing serious injury or death.



## S0300-BB-MAN-010

**WARNING**

The equipment should not be used to cut non-ferrous metals underwater since they do not oxidize and have to be melted. Experience has shown that this can result in a violent explosion which could be fatal.

A similar exothermic cutting method is the Seeler Enterprises LU-001 Exothermic Cutting Tool (Kerie Cable). Unlike a rigid electrode, the consumable electrode is a long flexible spiral cable with the center strand pulled out to allow for oxygen passage. The cable consists of six bundles of high tensile steel wire. The cordless cable is surfaced with a rough ultraviolet inhibitor which is encased in a plastic sheath. To facilitate connecting to the control panel, a threaded female fitting is crimped to one end of each length of cable.

**2-4.1 Advantages and Disadvantages of the Kerie Cable.** The advantages of the Kerie Cable are as follows:

- a. There is less training and skill required.
- b. It is applicable to all metal thicknesses.
- c. It has a longer burn time.
- d. It has the ability to cut in hard-to-reach spots without frequent electrode changing.
- e. There is no electrical hazard after ignition. The electrical circuit is used only for igniting the thermic cable.
- f. It cuts on the surface as well as underwater.
- g. It is lightweight.
- h. Only one gas (oxygen) is needed.

The disadvantages of the Kerie Cable are as follows:

- a. It requires more oxygen.
- b. It will not cut concrete, rock, or non-ferrous metals.

Learning to use the Kerie Cable is very simple. To familiarize the diver and the topside support crew with the equipment and operating procedures, the team should follow the set-up described below and perform a cut on the surface. Use a piece of mild steel plate as practice material. Set the oxygen pressure to about 200 psi and turn the Hoke valve to the ON position. Close the knife switch and touch the practice metal with the

## S0300-BB-MAN-010

tip of the Kerie Cable. The cable should ignite immediately. Lift the knife switch (switch off) when ignition takes place. Proceed to cut the metal, starting at the edge. Once in the water, the diver will quickly become accustomed to the feel, sound and use of the Kerie Cable.

**2-4.2 Materials Required for Kerie Cable Cutting.** The Seeler Enterprises LU-001 Exo-thermic Cutting Tool (Kerie Cable) is supplied with a surface control panel. (See Figure 2-8, which includes an oxygen regulator, an on-off and vent flow valve for the oxygen and a knife switch and electrical and oxygen connections. Oxygen, batteries and ground cable are not included.)

The following equipment is required:

- a. One control panel.
- b. One three-cylinder, 10-foot, high pressure (HP) oxygen manifold.
- c. Three full 220-cubic foot oxygen cylinders.
- d. One 100-, 200- or 250-foot extension lead.
- e. One insulating sleeve.
- f. One 6.4mm x 6.4mm (1/4-inch x 1/4-inch) British standard pipe (BPS) double male adapter.
- g. One 6.4mm x 3.2mm (1/4-inch x 1/8-inch) double male adapter.
- h. A length of 6, 9 or 12mm (0.24-, 0.36- or 0.48-inch) Kerie Cable.
- i. Two fresh 12-volt, 20-ampere hour batteries or a welding machine capable of supplying 400 amps/80 volts.
- j. One pair of heavy duty wire cutters.

S0300-BB-MAN-010

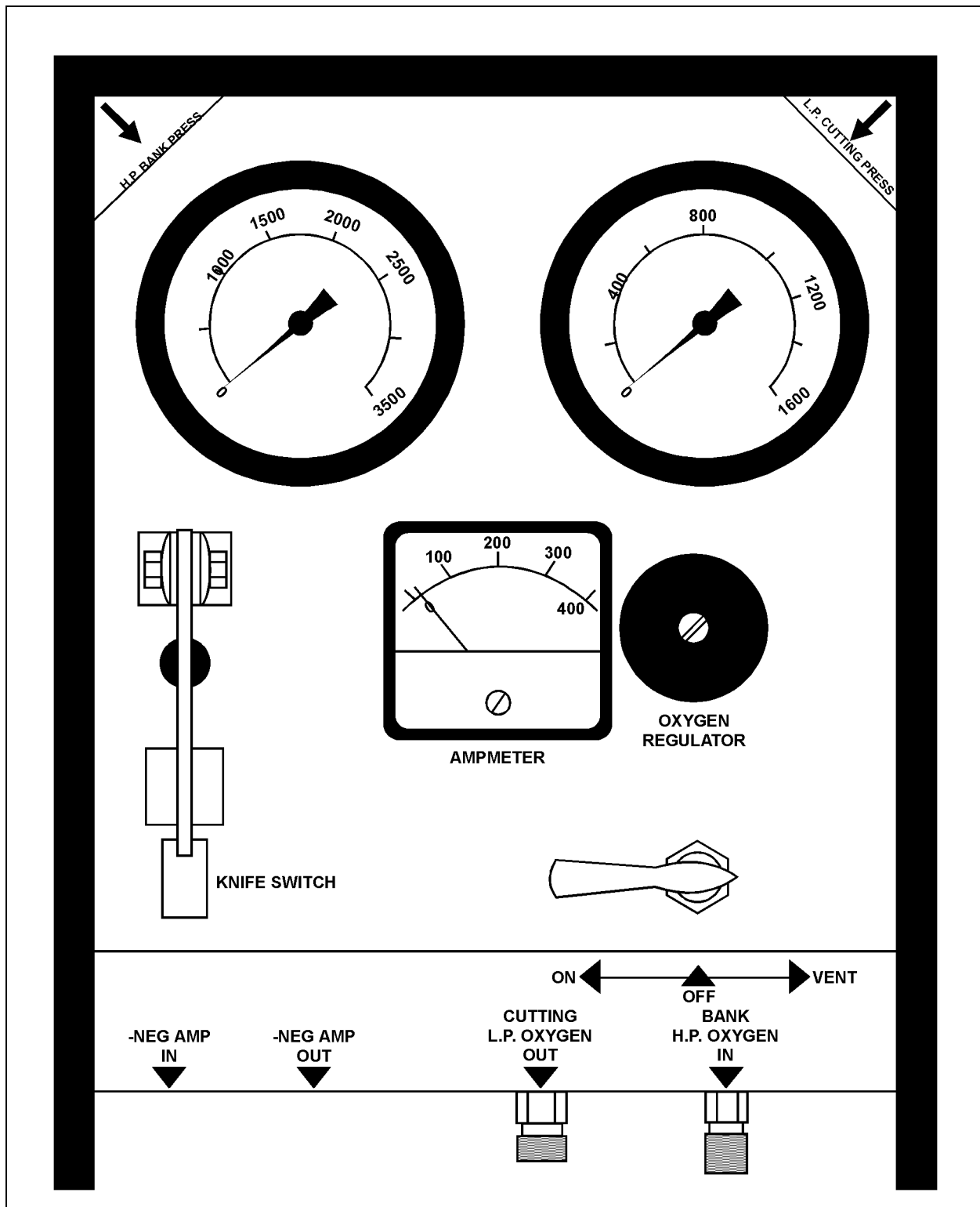

Figure 2-8. Seeler Kerie Cable Control Panel.

I

## S0300-BB-MAN-010

The Kerie Cable is manufactured in three sizes: 50-foot lengths of 9mm (0.36-inch) and 100-foot lengths of 12mm (0.48-inch) for cutting heavy plate wire and shackles, etc and 50-foot lengths of 6mm (0.24-inch) for cutting thinner plate, wire and shackles. The cable is the cutting electrode and is connected to the control panel via the extension lead, which supplies both power and oxygen to the cable.

The control panel is connected to three<sup>1</sup> oxygen cylinders using the 10-foot, HP manifold and to the power supply using the extension lead. Negative (-) amperage and low pressure oxygen are supplied through the control panel (see [Figure 2-9](#)).

While oxygen is flowing through the cable, it is ignited by closing the knife switch and touching the tip to the striker plate. The striker plate is connected to the positive (+) side of the paralleled batteries or a welding machine. The oxygen flow is directed to the cable through the three-way HOKE valve on the control panel. Once ignited, the knife switch is opened to cut off the power. The Kerie Cable will continue to burn until the oxygen is cut off or completely consumed. The burning cable can be stopped by turning the HOKE valve to the OFF position, which stops the flow of oxygen. The burning cable can be stopped almost instantly by turning the HOKE valve to the VENT position. This vents the oxygen to the atmosphere, allowing water to flood the cable and extinguish the flame. This should only be done in an emergency situation as flooding with water causes difficulties when attempting to relight the cable underwater.

**2-4.3 Equipment Set-up.** The following procedure should be followed when setting up the Kerie Cable equipment:

**WARNING**

It is very important that ignition not occur with oxygen pressure too low. To do so will cause the cable to burn inside itself and as full pressure is applied, the flame will burn out sideways along the length of the cable in a series of blow holes that can cause diver injury.

- a. Connect three full oxygen cylinders together with the 10-foot, HP manifold. Check the HP gauge for cylinder pressure.
- b. Turn the valve marked ON/OFF/VENT to the OFF position.
- c. Turn the regulator OFF.
- d. Connect the HP manifold to the fitting marked HP OXYGEN IN on the control panel.

---

1. Blanking plugs are supplied with the high pressure manifold for use on small cutting jobs, when only one oxygen cylinder is required.

S0300-BB-MAN-010

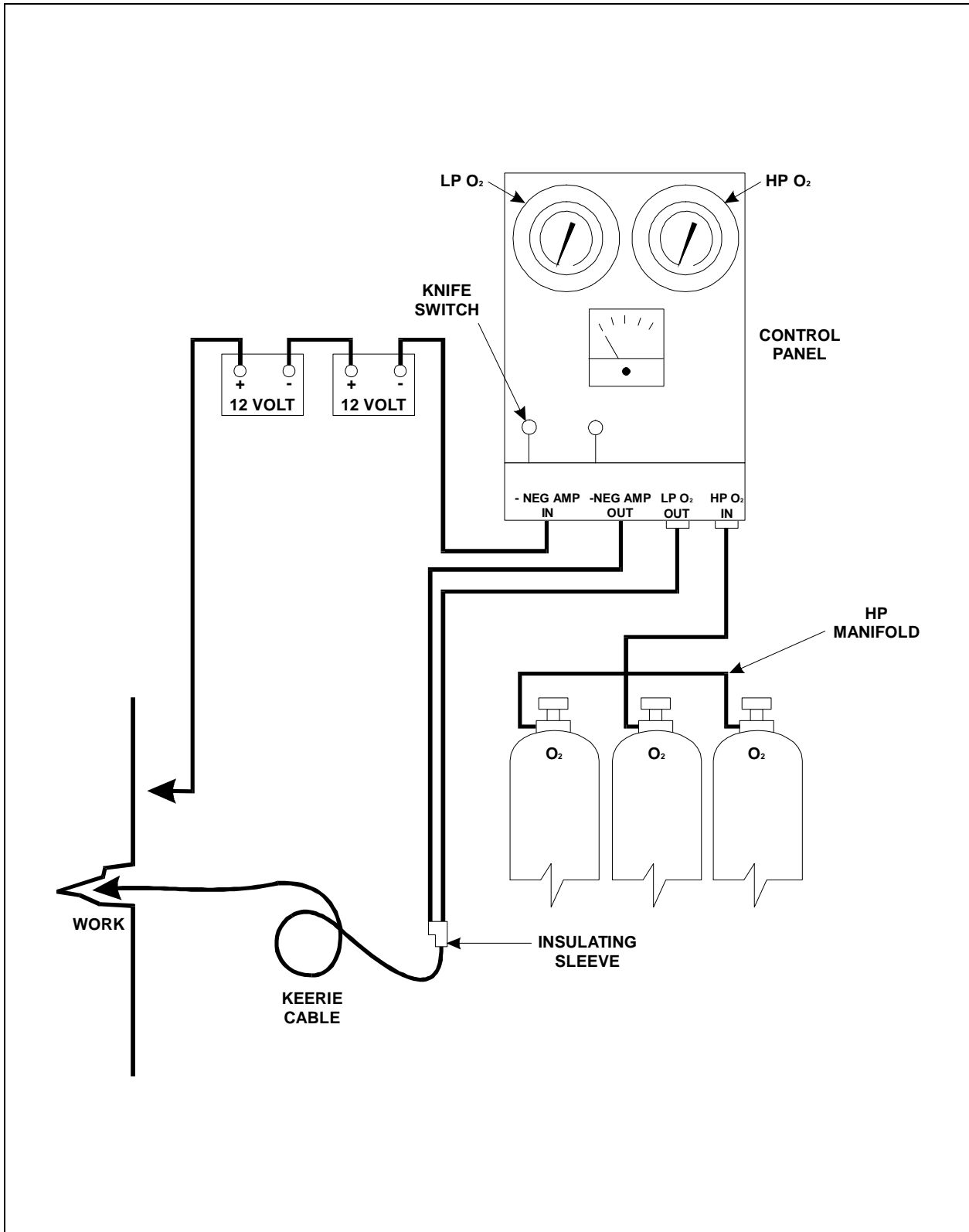

Figure 2-9. Typical Kerrie Cable Set Up.

## S0300-BB-MAN-010

- e. Connect a length of 100-, 200- or 250-foot extension lead to the control panel fitting marked LP CUTTING OXYGEN OUT.
- f. Open the knife switch.
- g. Connect a length of 100-, 200- or 250-foot electric lead to the control panel fitting marked NEG AMPS OUT.
- h. Place two fresh, 12-volt batteries of at least 20 ampere hours on a non-conductive surface (wooden plate, rubber mat etc). Connect the batteries in series.
- i. Connect the negative side of the batteries to the fitting marked NEG. AMPS IN on the control panel.
- j. Connect the positive side of the batteries to a suitable length of wire with the opposite end connected to the striker plate (ground).

**CAUTION**

Ensure that the red insulating sleeve is correctly reinstalled after replacing the Kerie Cable.

**2-4.4 Kerie Cable Preparation.** Kerie Cable comes from the manufacturer in individual coils that are tightly wound and should be opened and inspected for cuts in the plastic coating. The following procedure should then be followed:

- a. Recoil the Kerie Cable in large loops to prevent kinking.
- b. Connect the cable to the extension leads with the appropriate reducer.
- c. Blow down the hose with oxygen for approximately 20 seconds.
- d. Slide the red plastic insulating sleeve along the Kerie Cable until the joint between the cable and the extension lead is completely covered.
- e. The equipment is now ready for cutting.

**2-4.5 Cutting Underwater.** After the striker plate is secured at the work site, the cable should be pressurized and passed to the diver. The cable is taken down with sufficient oxygen flow to exclude water from entering the bore. The gas pressure need only be increased to overcome hydrostatic pressure.

## S0300-BB-MAN-010

Upon reaching the work site, the diver, when ready, should call and wait for gas pressure to be increased. A delay of approximately 20 seconds is necessary between applying full cutting-gas pressure and closing the knife switch to allow time for the oxygen pressure to build up along the full length of the cable. The following procedure should be followed:

- a. The tender will increase the oxygen supply to the proper over bottom pressure. (See [Table 2-6](#) for proper over bottom pressure formulas.)
- b. The diver calls for SWITCH ON when an increase in the amount of bubbles is observed emerging from the cable.
- c. The tender (phone talker) closes the knife switch and then responds with SWITCH ON.
- d. The diver should then touch the tip of the cable to the striker plate. The ammeter will give a reading as the diver attempts ignition and then will fall back to zero when ignition is achieved.
- e. Once it is obvious that ignition has been successful, the diver announces, "I have ignition."
- f. The tender (phone talker) will then open the knife switch, isolating the electric circuit.

Typically, the Kerie Cable burns at about two feet per minute. The selection of cable size depends on the thickness of the metal being cut (see [Table 2-7](#)). [Table 2-8](#) lists typical oxygen/cable consumption ratio.

**2-4.6 Cutting Technique.** To begin cutting, touch the ignited tip of the Kerie Cable to the material to be cut. The material will instantly begin to oxidize and burn away. Hold the cutting cable at about 90° perpendicular to the work, keeping the tip in constant contact with the material being cut. Keep the tip moving into the cut and keep hands at least six inches from the flame .

**CAUTION**

Do not force or poke the cable into the material being cut, since this will cause blow-back.

**2-4.7 Cutting Thin Metals.** When cutting thin steel plate, wire rope or routine light work, the 6mm or 9mm (0.24-inch or 0.36-inch) Kerie Cable should be used. Use a

## S0300-BB-MAN-010

brushing motion and several passes to eliminate molten metal from the cut.

**2-4.8 Cutting Thick Metals.** When cutting thicker metal (2-1/2 inches and greater), use the 12mm (1/2-inch) cable and a brushing motion to allow the metal surrounding the cut to cool enough to prevent molten metal.

Thick steel, such as propeller shafting, should be cut from the outside, working around the circumference, withdrawing the Kerie Cable every few seconds to allow water to enter the cut. A brushing or stroking action in the direction of the intended cut should be used.

**Table 2-6. Oxygen Regulator Settings for Kerie Cable Cutting**

Cable Size (mm)(in.)	Over Bottom (OB)		Pressure Formula (psi)
6mm (0.24 in.)	D + (250 to 300 psi)	=	OB <sup>1</sup>
9mm (0.36 in.)	D + (300 to 340 psi)	=	OB <sup>1</sup>
12mm (0.48 in.)	D + (340 to 380 psi)	=	OB <sup>1</sup>

1. A 40 to 50 psi range is allowed for diver preference.

Where D = depth in feet of sea water

Example: At a depth of 60 FSW using 6mm cable, overbottom pressure is:

$$60 + 275 = 335 \text{ psi.}$$

**NOTE**

Kerie Cable is not recommended for use deeper than 300 FSW.



## S0300-BB-MAN-010

**Table 2-7. Kerie Cable Size/Metal to be Cut<sup>1</sup>**

<b>Cable size (mm)</b>	<b>Metal Thickness (in.)</b>
6 (0.24 in.)	up to 1
9 (0.36 in.)	1 to 2-1/2
12 (0.48 in.)	over 2-1/2

1. Based on manufacturer's data.

**Table 2-8. Kerie Cable Oxygen and Cable Consumption Ratio**

<b>Cable Size (mm)</b>	<b>Average Cable Consumed (ft. per minute)</b>	<b>Average Oxygen Consumed (psi per minute)</b>
6 (0.24 in.)	2.1	13.9
9 (0.36 in.)	2.2	35.5
12 (0.48 in.)	2.4	40.6

## S0300-BB-MAN-010

**2-4.9 Re-lighting Cable Underwater.** After calling for GAS OFF, the diver should continue to rub the cable against the work to prevent the molten plastic coating from forming insulation over the inner wire core. This step is necessary to ensure reignition. When operations require reignition of the Kerie Cable for more than a second or third time, consideration should be given to the use of a DC welding machine due to limitations of the batteries.

**2-4.10 Emergency Off Safety Procedures.** The diver indicates emergency off action required by calling out EMERGENCY OFF and sending one hand-pull signal on the umbilical. The equipment tender turns the HOKE valve to the vent position. The cable will flood and the flame will stop immediately.

**2-4.11 Loss of Communications.** In the event of loss of communication, the cutting operation must be stopped until communications are restored. Diving supervisors shall establish an EMERGENCY OFF procedure to deal with loss of communications.

**2-4.12 Equipment Tender.** The phone talker may be assigned the task of equipment tender. The tender will **NOT** close the circuit unless specifically directed to do so by the diver. When directed, the tender will confirm each change with the diver.

The equipment tender will ensure that the diver has the proper oxygen overbottom pressure in accordance with [Table 2-6](#) and must remain within reach of the control panel at all times.

**2-4.13 Electrical Precautions.** It is important that the specially designed 10-foot, HP manifold, joining the oxygen cylinders with the panel, **NOT** be substituted. This is an electrically insulated manifold designed to prevent any return current from traveling up the steel-braided hose to the oxygen cylinders. All electrical connections shall be tight and insulated with red plastic sleeve or other non-conductive material, (rubber tape, heat-shrink tubing, etc).

**2-4.14 Post-Dive Maintenance.** Post-dive maintenance for the Kerie Cable is quite simple. The following procedures are recommended:

- a. Rinse equipment which has been exposed to salt water with fresh water.
- b. Blow any remaining moisture out of unused portion of cable and dry thoroughly.
- c. Return equipment to stowage in an oil free environment.

## S0300-BB-MAN-010

**2-5 SHIELDED METAL ARC CUTTING**

Underwater shielded metal-arc cutting is a simple process. It employs a stick-type electrode but can be accomplished with almost any waterproofed, mild steel electrode. Shielded metal arc has the following advantages over oxygen-arc cutting processes:

- a. It can cut corrosion and oxidation resistant steels and non-ferrous metals of all thicknesses.
- b. It can be used when no oxygen is available.

**2-5.1 Principles of Operation.** Shielded metal-arc cutting is a process in which the metal is cut by the intense heat of the arc. The heat melts a localized area of metal, forming a small molten pool. The pool will not flow enough to produce a good cut due to the rapid cooling from the quenching effect of the surrounding water. Therefore, the tip of the electrode must be manipulated to push the molten metal out of the kerf.

**2-5.2 Materials.** The equipment and materials required for shielded metal-arc cutting are the same as those used in shielded metal-arc welding, which is described in detail in [Chapter 3](#). Commercially waterproofed rods are listed in [Table 2-9](#), however, they are more expensive than surface electrodes. For extended cutting using this process, consideration should be given to the more economical on-site waterproofing of surface electrodes covered in [Appendix E, paragraph E-5.1](#).

**CAUTION**

Due to the flammability and toxicity of fumes from waterproofing compounds, waterproofing must be conducted in a well-ventilated space, clear of any open flames or spark-producing machinery.

**2-5.3 Waterproofing Electrodes.** The Andersen Easy weld #1 and BROCO SofTouch are both commercially prepared waterproof electrodes and have passed Navy welding qualification testing. The other electrodes used in underwater cutting are essentially surface welding electrodes. Before being used underwater, they must be waterproofed to protect the covering from deterioration by sea water. Although many paints, varnishes, shellacs or tapes have been satisfactory for waterproofing, the materials listed in [Table 2-9](#) have proven to last longer in sea water.

The waterproofing materials are applied by dipping the electrode into the solution and allowing the coating to dry. See [Appendix E](#) for detailed waterproofing instructions.

## S0300-BB-MAN-010

**2-5.4 Underwater Shielded Metal-arc Cutting Techniques.** The diver should understand that this process merely melts the metal and does not oxidize or consume the metal as in oxy-arc cutting. The molten metal will not run out of the cut on its own, but must be pushed out by manipulation of the electrode tip. By paying careful attention to the molten pool, the diver can master this process in a short period of time. This technique can be used effectively for cutting of steel, brass, copper and other copper-based alloys.

**Table 2-9. Material Requirements for Underwater Shielded Metal-Arc Cutting**

Item	Description	Specification
Andersen Easy <sup>1</sup> Weld #1	Carbon Steel (E7014)	--
BROCO Sof- <sup>1</sup> Touch	Carbon Steel (E7014)	--
Electrodes	E6013	--
	E7014	--
Electrode Waterproofing Materials	Epoxy 152 <sup>1</sup>  Sea Lac 30-L2093  Non-petroleum-based, clear, polyurethane	MIL SPEC P-24441  --  --

1. Commercially available

## S0300-BB-MAN-010

**2-5.5 Drag Technique.** Steel plate can be cut simply by dragging the electrode along the desired line of cut. The drag technique can be used to cut 1/4-inch steel plates with 300 amperes of current. 3/8-inch plate requires using 400 amperes of current. This technique works more effectively using larger electrodes and higher currents. The diver may find that using the drag technique in a flat position is more effective than in other positions.

When cutting thicker plates, a slow, short-stroke, sawing motion must be used to push the molten metal out of the far side of the cut. This technique is illustrated in [Figure 2-10](#).

Skillful application of this sawing technique makes the metal-arc cutting process practical over a wide range of thicknesses. When cutting non-ferrous metal round stock, a sawing motion should be used, starting at the bottom and pushing through.

## 2-6 CONCLUSION

This chapter has presented two methods of underwater cutting. Attention to safety procedures contained within this chapter and in [Appendix D](#) must be observed and carefully followed.

S0300-BB-MAN-010

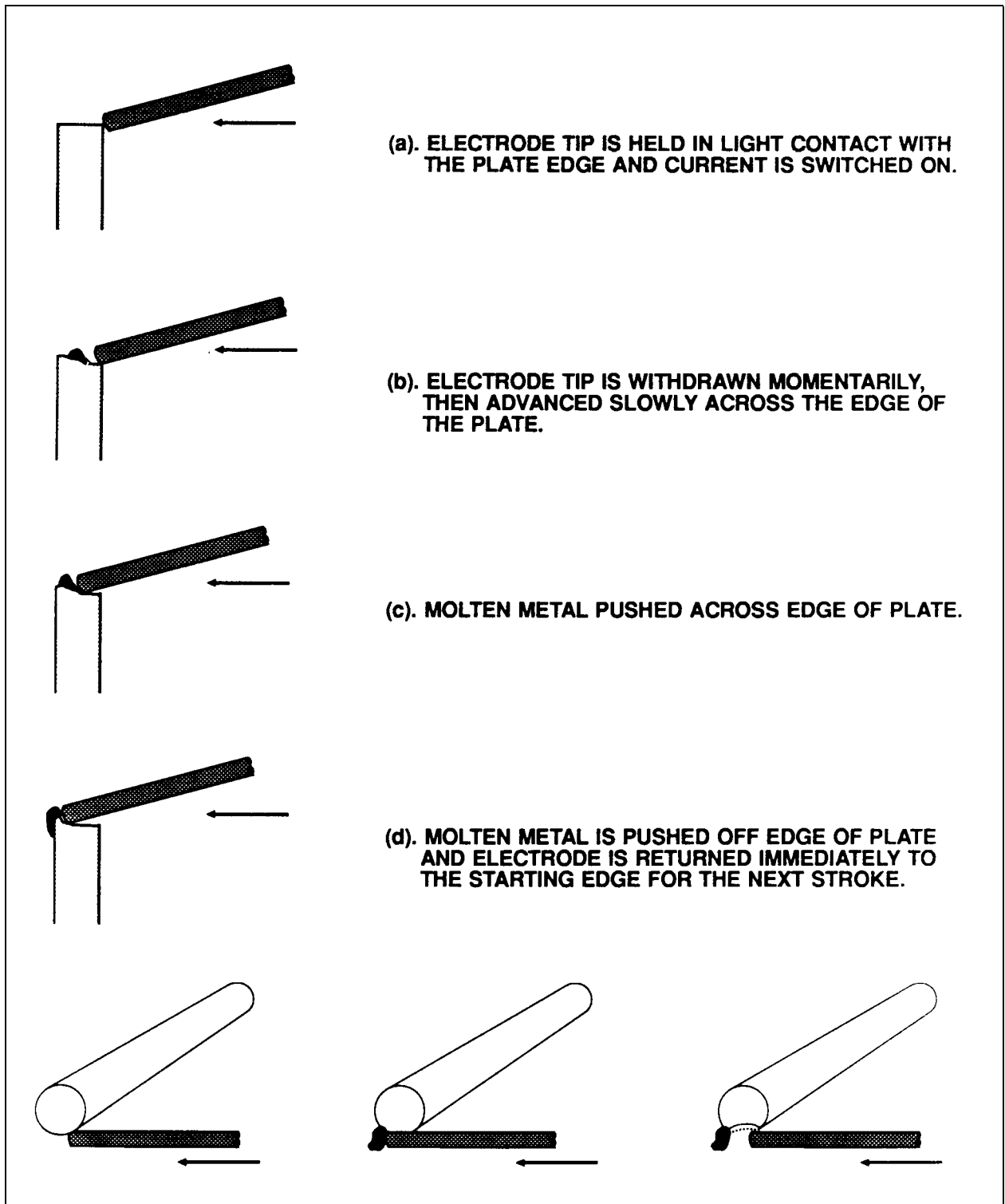

Figure 2-10. Technique for Underwater Shielded Metal-Arc Cutting of Thick Plate and Round Stock.

S0300-BB-MAN-010

S0300-BB-MAN-010

---

## CHAPTER 3

---

### UNDERWATER WELDING

#### WARNING

Serious injury or death may result when adequate precautions are not followed during underwater cutting or welding operations. Supervisors shall ensure that all personnel become thoroughly familiar with all of the safety precautions covered in [Appendix D](#).

#### WARNING

The position of the ground in relation to the diver must be such that at no time does the diver or his equipment get between the ground and the electrode. The diver must avoid becoming part of the electrical circuit.

#### WARNING

AC power shall not be used for underwater cutting or welding due to the extreme danger involved with AC current underwater. Electrical shock produced by AC current prevents voluntary relaxation of the muscles controlling the hand. Consequently, the diver may be unable to let go if his body or equipment accidentally enters the electrical circuit.

### 3-1 INTRODUCTION

Although underwater welding does not have as many applications in marine salvage operations as underwater cutting, welding is an extremely important and useful process. By substituting welding for mechanical methods of joining, the overall cost and time



## S0300-BB-MAN-010

spent on the job can be reduced considerably. Historically, the Navy has performed most underwater welding for the purpose of making temporary repairs to waterborne ships. Specific wet and dry welding techniques applicable to underwater ship husbandry are properly addressed in the *Underwater Ship Husbandry Manual*. This manual addresses basic welding techniques and their application to salvage operations. The joining of padeyes and patches onto recoverable objects are typical examples of underwater salvage welding.

Until mid-1960, all underwater welds were wet welds. The technique was usually limited to the shielded metal arc process (commonly known as stick welding). Wet welding is a situation where both work and welder are in contact with the water. Today there are two additional underwater welding methods available. While each technique has individual merits and limitations, both share one common factor: water is not in direct contact with the weld area. In a sense, the welding is “dry.” [Paragraph 3-2](#) discusses the two new methods.

## 3-2 MECHANICAL BARRIERS

**3-2.1 Cofferdams and Caissons.** Cofferdams and caissons are used at the waters edge or in the splash zone and below the water surface. While the structure excludes the surrounding water from the work area, its upper section is open to the atmosphere. This technique is depth-limited by the physical size of the cofferdam. Typical applications include ship’s hulls, dock and harbor facilities.

### WARNING

Oxygen partial pressure increases with water depth, thereby creating a fire hazard in habitat environments. No habitat welding will be performed in an air environment at depths greater than 60 FSW. Habitats shall be filled with an inert gas at depths greater than 60 FSW.

**3-2.2 Mini-Habitats.** Mini-habitat welding makes use of a small, easily portable, gas-filled enclosure. Often mini-habitats are transparent plexiglas boxes, which are placed over the joint by a diver. Water is displaced by an inert gas or air supplied from the surface. In this instance welding is performed at elevated ambient pressures. Depending on the size of the enclosure, the diver is partially immersed in water (only the diver’s hands and the welding torch are inside the habitat). This method requires adequate visibility and is limited to areas with clear access.

In general, dry welds are better than wet welds because cooling rates are slower. Both of the devices described above are methods of excluding water from the weld area, thereby creating a dry environment where dry welds and welds requiring more advanced

## S0300-BB-MAN-010

techniques may be produced. In salvage, most underwater welding consists of joining fairly simple steel patches to hull plating. Therefore, wet welding may be acceptable for most patching applications.

### 3-3 SHIELDED METAL ARC WELDING

Shielded metal arc welding is produced by heating with an electric arc created between a flux-covered metal electrode and the work. The arc creates intense heat, 7,000 °F to 11,000 °F, concentrated in a very small area. It results in melting of the parent metal parts, the core wire and some of the flux covering. Other elements of the flux covering decompose to form a gaseous shield around the arc. This shield protects the molten metals from contamination by the surrounding atmosphere. As the electrode melts, small drops or globules are formed, forced across the arc and deposited on the work into a molten pool which solidifies, forming a bead of weld metal.

The diver should understand that the drops or globules do not simply fall into the pool by gravity, but are forced by the electric current flow. Otherwise, overhead welding would not be possible.

### 3-4 WET WELDING

The wet welding process used for salvage operations is usually a simple underwater joining technique. The materials required are commercially manufactured shielded metal arc equipment and waterproofed electrodes. Minimal ancillary devices are needed. These include lighting, staging and hand tools.

There are advantages to wet welding. The underwater welder can work freely on any portion of complex structures or on sections with restricted access, whereas other underwater techniques may encounter difficulties. Patching can be performed faster and at less cost because no time is lost in construction and installation of enclosures.

Because standard welding power sources and equipment are used, a wet welding job can be easily mobilized at remote job sites. Wet welding also allows more freedom of patch design and size of patch sections.

### 3-5 SHIPBUILDING MATERIALS

The Navy diver should be familiar with the different types of steel used in shipbuilding in order to select the appropriate welding electrodes. Today shipbuilders have a wide range of steels which are used in the construction of ship's hulls and superstructures. Quite often, ship hulls are comprised of more than one type of steel. A ship may have stronger steel at the keel, garboard and sheer strakes and at the turn of the bilge where the stresses are higher. In these cases, electrodes of higher strength steel are applicable. Perhaps the simplest approach to these materials is by strength, although this is not the only criteria for selection. [Table 3-1](#) divides some of the more common steels into three groups. Oftentimes, accurate information is not readily available when needed. A quick, field-expedient method to determine the type of electrodes to use is as follows:

## S0300-BB-MAN-010

- a. Cut a small sample of the material to be welded and make a Tee fillet weld specimen similar to the one illustrated in [Figure 3-1](#).
- b. Wet weld the specimen and break it with a sledgehammer. If it breaks easily after being welded with mild steel electrodes, it is more than likely that the steel is of a high carbon content and should be welded with austenitic electrodes. On the other hand, a specimen that bends a great deal before breaking indicates low carbon content and may be welded with mild steel electrodes.

**Table 3-1. Guide to Steels and Electrodes for Wet Welding**

<b>Steel</b>	<b>Example</b>	<b>Approximate Tensile Strength (psi)</b>	<b>Use</b>	<b>Welding Electrode</b>
Mild and Carbon	ASTM-A36 ABS-A32	50,000	Hull shell plating	E6013 E7014 E308 E310
High strength	HTS ASTM-A3537 Class 1	70,000 to 90,000	Shell plating bilge turns rudders	E7014 E308 E310
Very high strength	HY-80 HSLA-80	>90,000 >90,000	Submarines Some rudders, garboard and shear strakes and bilge turns	*

\* Not recommended

S0300-BB-MAN-010

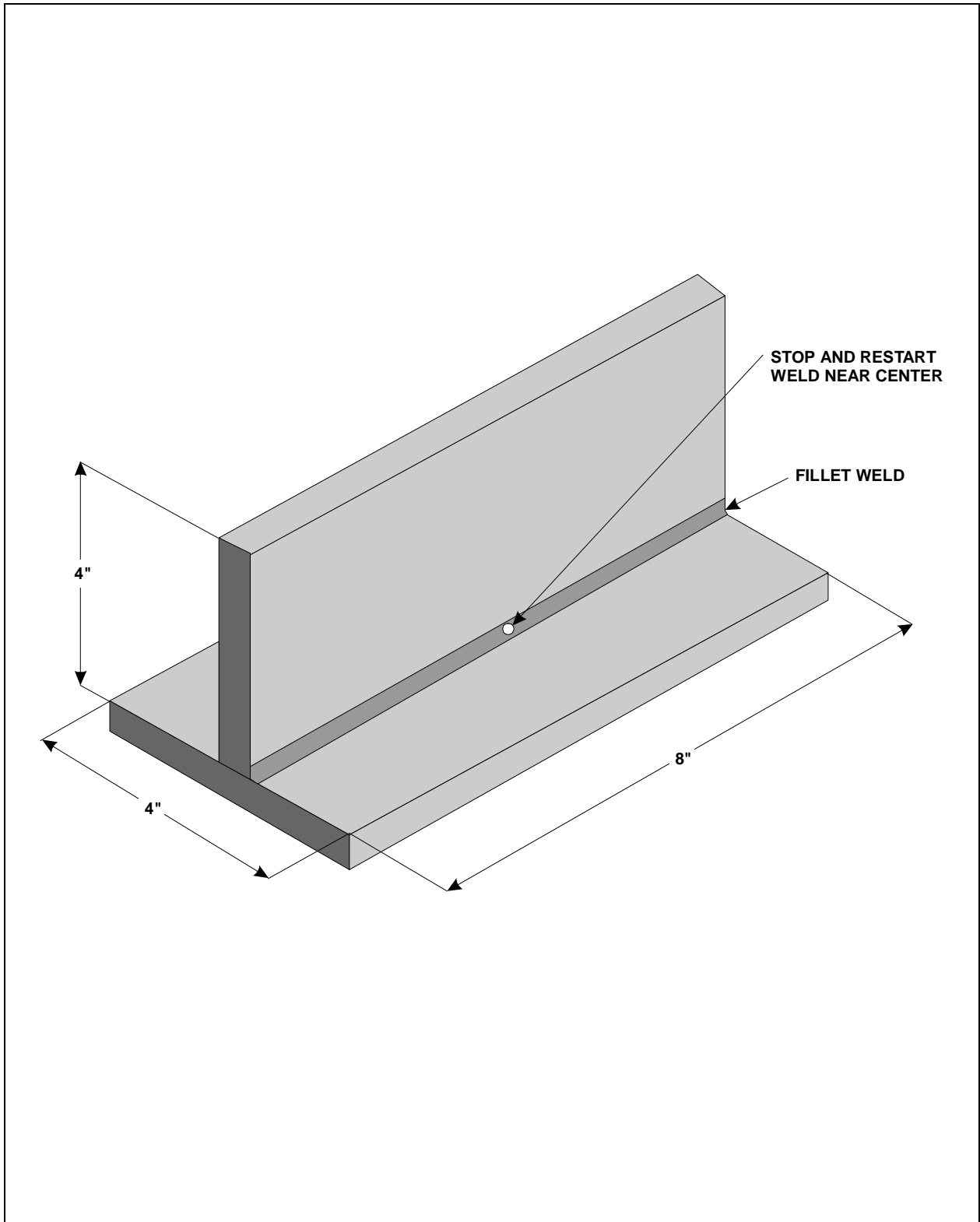

Figure 3-1. Test Specimen for Tee Fillet Weld.

## S0300-BB-MAN-010

**NOTE**

Very high strength steels, like HY-80, are not recommended for wet welding because of cracking problems stemming from the intense heat produced by the welding process followed by rapid cooling of the weld metal by the ambient water.

For high strength steels, a stainless steel electrode gives better results.

**3-6 MATERIALS USED IN UNDERWATER SHIELDED METAL ARC WELDING**

Equipment used for shielded metal arc welding is discussed in [Chapter 4](#). Consumable materials required for shielded metal arc welding consist of commercially produced waterproofed wet welding electrodes. [Table 3-2](#) lists the preferred electrodes identified during wet welding screening and certification tests conducted by the Navy.

**3-6.1 Underwater Shielded Metal Arc Welding Electrodes.** Commercial manufacturers have made significant progress in the development of waterproofing systems for wet welding electrodes. Details of these systems are proprietary to each manufacturer; however, the results of their cumulative efforts have produced a new generation of wet welding electrodes. Certain electrodes mentioned in [Table 3-2](#) are manipulative types for use in all positions. With the correct welding procedures and equipment, weld deposits display excellent bead appearance and improved mechanical properties.

[Table 3-3](#) depicts recommended welding currents and arc voltages to be used as a starting point for wet welding to depths up to 50 FSW.

**3-6.2 Tong Test Ammeter.** The tong test ammeter ([Figure 4-9](#)) is a portable instrument that will quickly measure current flowing in a circuit without making electrical connections to it. It is a most important tool use while setting-up for and during electric underwater cutting and welding operations. The tong test ammeter is discussed in greater detail in [Chapter 4](#).

**3-6.3 Electrode Polarity.** Wet welding is usually conducted using STRAIGHT POLARITY, sometimes referred to as DC ELECTRODE NEGATIVE, which results in longer life of the electrode holder. While straight polarity, electrode negative is the traditional method, this is by no means a hard and fast rule. Occasionally, more successful results may be obtained using reverse polarity, DC ELECTRODE POSITIVE. Some typical applications for reverse polarity include the following:

## S0300-BB-MAN-010

**Table 3-2. Electrodes for Underwater Shielded Metal-Arc Welding**

<b>Size</b>	<b>Description</b>	<b>Specification</b>
<b>Commercially Prepared Waterproof Electrodes</b>		
1/8" Andersen Easy <sup>1</sup> Weld #1	Carbon Steel (E7014)	--
1/8" BROCO Sof-Touch <sup>1</sup>	Carbon Steel (E7014)	--
1/8" BROCO SS	Stainless Steel (E3XX)	--

1. These electrodes have passed Navy qualification testing; larger sizes are available, but have not yet been tested by the Navy.

**Table 3-3. Recommended Amperage Settings for Wet Welding to Depths of 50 Feet**

<b>Electrode</b>		<b>Welding Position</b>			
<b>Type</b>	<b>Size inch</b>	<b>Horizontal Amps</b>	<b>Vertical Amps</b>	<b>Overhead Amps</b>	<b>Arc<sup>1</sup> Voltage</b>
E7014	1/8	140-150	140-150	130-145	25-35
	5/32	170-200	170-200	170-190	26-36
	3/16	190-240	190-240	190-230	28-38
E3XX	1/8	130-140	135-140	125-135	22-30

1. Arc voltage, also referred to as closed-circuit voltage, is the voltage recorded by the voltmeter as welding is in progress. Tong meter amperage reading should also be recorded as welding is in progress.

## S0300-BB-MAN-010

- a. Manufacturer's recommendations, particularly for stainless steel electrodes.
- b. Improved running characteristics of the electrode.
- c. Control of weld bead shape and penetration.
- d. Altered magnetic fields to reduce magnetic arc blow.

### 3-7 UNDERWATER WELDING ARCS

The welding arc does not behave underwater as it does on the surface and the activity of the gas bubble is particularly important to successful completion of the underwater weld. When the arc is struck, the combustion of the electrode and the detachment of water creates a gas bubble or envelope, as illustrated in [Figure 3-2](#). As the pressure within the bubble increases, it is forced to leave the arc and meet with the surrounding water while another bubble forms to take its place. Then, as this pressure head becomes greater than the capillary force, the bubble breaks down. Therefore, if the electrode is too far from the work, the weld will be destroyed as the gases explode and blow through. If the travel speed is too slow, the bubble will collapse around the weld and destroy the possibility of producing an effective weld.

#### NOTE

Thick, gauntlet-type rubber gloves in good condition, worn over a pair of playtex-type gloves afford the best protection against electrical shock. They should be secured at the wrist to prevent slag from getting inside the glove. When working in cold water, wetsuit gloves in good condition, worn over surgical gloves are equally effective.

### 3-8 CONDITIONS ADVERSE TO UNDERWATER WELDING

Before welding operations are started, the job should be inspected to determine whether or not the welding can be performed effectively at the work site. Satisfactory underwater welds are more difficult than welds laid down topside. The following factors make underwater welding difficult:

- a. Diving apparel
- b. Where a steady platform cannot be provided from which to weld. (Working near the surface in rough water makes it difficult to provide a stable platform. When working from a stage, it is preferable to attach the stage to the object being welded rather than to the salvage ship, diving launch or float, since the rising and falling of the surface vessel in rough water changes the position of the stage relative to the object being welded.)

S0300-BB-MAN-010

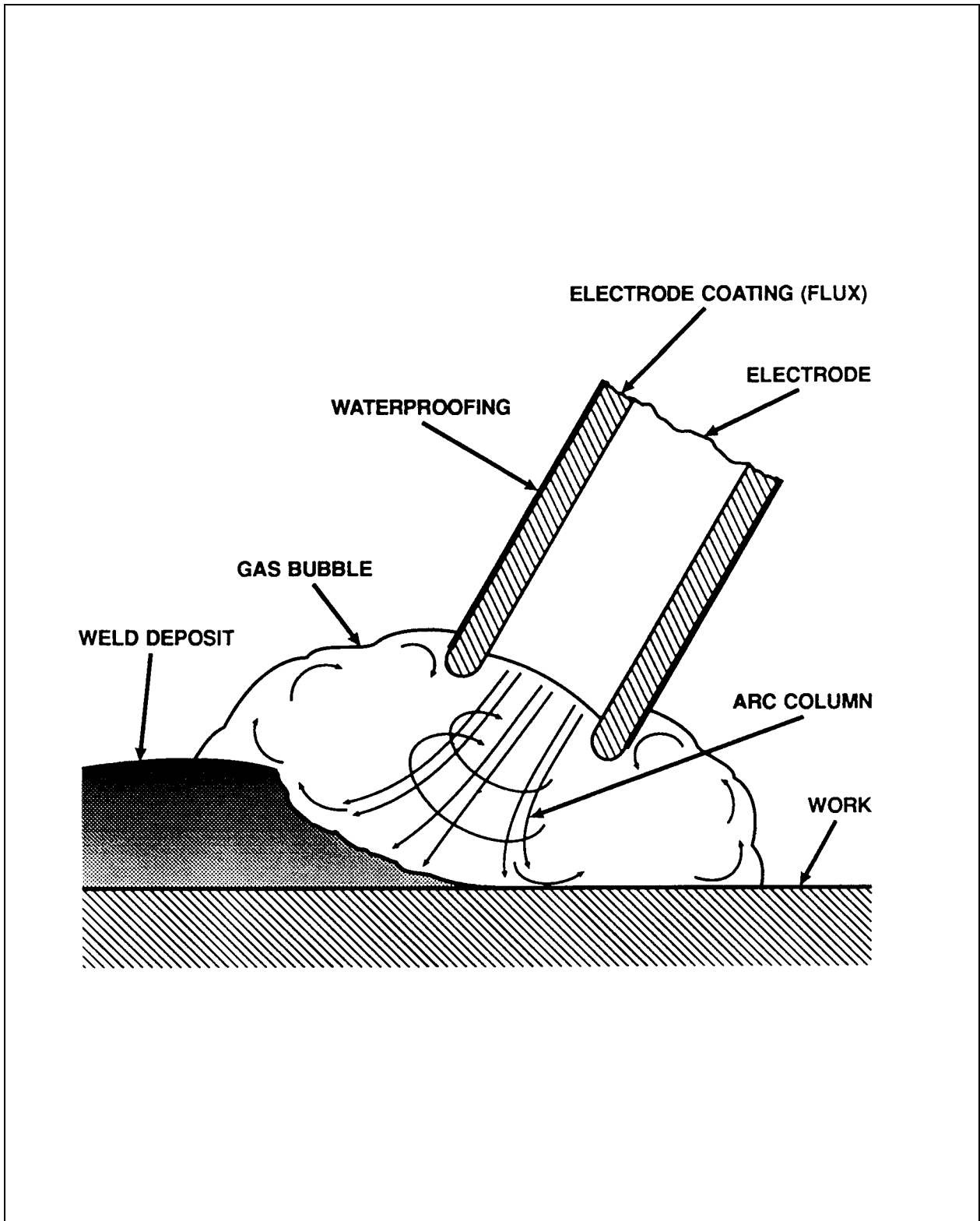

Figure 3-2. The Underwater Welding Arc.



## S0300-BB-MAN-010

- c. Adverse currents,
- d. Low temperature,
- e. Where the metal thickness is less than 0.20 inch.
- f. Where the fit-up is poor. A 1/8-inch gap should be considered the maximum permissible for a quality wet weld using the self-consuming technique and 1/8-inch electrodes.
- g. As the depth increases, due to the increase in hydrostatic pressure.
- h. Where the visibility is extremely low and the diver has no groove to follow.

### 3-9 STRENGTH OF UNDERWATER FILLET WELDS

The strength of a completed weld joint may well become the most important factor in the success of an entire salvage operation. The loading on a member, such as a padeye, involves both static and dynamic forces. Dynamic loading may be a combination of tension, compression, shear and bending. Because there is always some doubt concerning the magnitude of loading, a safety factor of six is used in calculating the required length of a fillet weld, which in turn determines the strength of the weld.

The second factor is the overall length of the fillet weld. In many cases, this will be determined by the size of the patch or work in question. However, if in doubt, use the 1,000 pounds per linear inch as a safe guideline. For example, a padeye for a 10-ton load will require 20 linear inches of fillet weld, as shown below:

$$\frac{20,000 \text{ pounds}}{1,000 \text{ pounds per linear inch}} = 20 \text{ inches of weld}$$

Before going into actual welding procedures, a few word of definition are required. The primary application for wet welding is the fillet weld. Groove welds may also be worked. For best results when welding a groove weld, a backing strip should be used.

**3-9.1 Parts of a Weld (Definitions).** The following terms are used to describe the parts of a weld. The **FACE** is the exposed surface on the side from which the weld was made. The **TOE** is the junction between the face of the weld and the base metal. [Figure 3-3a](#) illustrates. The **ROOT** of a weld includes the points at which the bottom of the weld intersects the base metal surfaces, as seen in cross section. [Figure 3-3b](#) illustrates weld **ROOTS**. The **LEGS** of a fillet weld are shown in [Figure 3-3c](#). When looking at a triangular cross section of a weld, the **LEG** is the portion of weld from the **TOE** to the **ROOT**.

S0300-BB-MAN-010

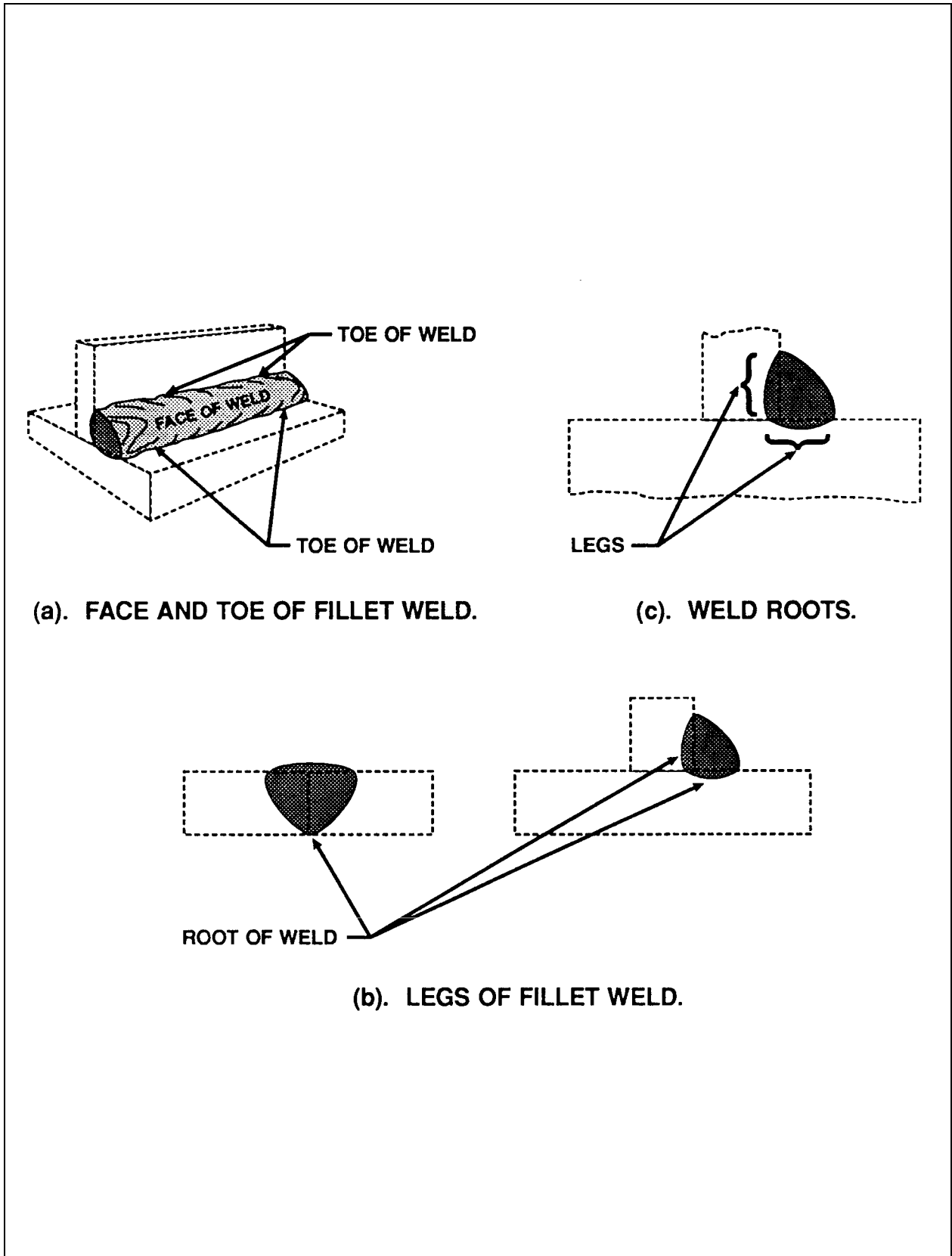

Figure 3-3. Parts of a Weld.

## S0300-BB-MAN-010

**3-9.2 Fillet Weld.** A fillet weld is a triangular weld used to join two surfaces that are at approximately right angles to each other. i.e., lap, tee and corner joints are normally welded with a fillet weld. A fillet weld should have a leg length equal to the plate thickness up to 3/8-inch plate. For plate thicknesses 3/8-inch and greater, a minimum of 3/8-inch leg length is required on all wet welds.

As with surface welding, the use of larger wet welding electrodes will result in greater weld metal deposition. However, the larger electrodes tend to produce more porosity (gas voids) in the deposited weld metal. Also, a larger single pass weld will have a lower toughness and an equivalent size multipass weld; this is the result of the tempering effect that each pass of the multipass weld has on the preceding passes.

For most positional work, a 1/8-inch electrode is recommended. Therefore, the diver will need to make a number of passes, usually 3 to 5, to achieve a 3/8-inch leg length. The number of runs will be determined by position and technique. The important point is not the number of runs, but obtaining the 3/8-inch leg length. In cases where the metal to be welded is thin and in **all overhead** work, a 1/8-inch electrode is required. Using the smaller electrode means more passes, but as previously stated, it allows succeeding passes to temper the preceding ones. Multipass welds using smaller diameter electrodes will actually result in higher quality wet welds with better metallurgical properties.

**3-9.3 Trial Weld.** As in all welding, good root penetration and avoidance of defects are important. In some cases, a trial weld will be required on site. This should be done at the working depth and in the most difficult position required, usually overhead. The specimen weld should be brought to the surface and inspected before the actual welding dive commences. A visual inspection should be conducted for bead profile and lack of defects. The weld may also be Dye Penetrant Tested (PT) or Magnetic Particle Tested (MT). If neither of these testing methods are available, break the specimen with a sledgehammer to determine how easily it breaks. The weld interior should then be inspected for slag entrapment and/or lack of fusion into the root.

### 3-10 SURFACE CLEANING

It is most important to properly prepare the surface to be welded because a satisfactory weld cannot be made over thick paint, rust or marine growth. The initiation of an arc may be impossible or, at best, very difficult when the surface has not been made ready for welding. Even a slightly rusty surface will adversely affect the quality of stainless steel and high nickel wet welds. Surfaces to be welded and adjacent surfaces for a distance of approximately 1/2-inch must be cleaned to sound metal.

Plates or patches should be prepared or cleaned aboard ship or above water with a sander, grinding wheel or by flame cleaning before being lowered for fitting and welding by the diver. Cleaning the base metal surfaces underwater necessitates strenuous application of the scraper, chipping hammer or wire brush. Mechanical methods of cleaning, such as a high-pressure water jet cleaning tool or pneumatic or hydraulic tools, should be considered to aid in cleaning underwater surfaces. In a multiple pass weld, each bead must be thoroughly cleaned and inspected for defects before depositing the next bead.

## S0300-BB-MAN-010

**3-11 JOINT FIT-UP**

Since most underwater tasks are more cumbersome than similar topside work, the proper positioning of large members or plates underwater for welding is also quite difficult. Positioning and fitting must be done with thoroughness and care to ensure a satisfactory weld. In underwater fillet welding, it is important that there be no gap at the root of the fillet before welding. When the gap cannot be eliminated entirely, it should be as small as the conditions will permit. For best results, a patch that is to be welded to a hull plate should be accurately flared to the contour of the hull plate before final fitting in place by the diver. Even the most expert welding is ineffective when the fit-up is poor. It is better to spend a little extra time fitting than to spend a lot of time welding.

**3-12 UNDERWATER SHIELDED METAL ARC WELDING TECHNIQUES**

There are two basic techniques used today in shielded metal arc wet welding: the self-consuming technique and the manipulative or weave technique. [Paragraph 3-12.3.3](#) describes the advantages of the self-consuming technique for the less experienced underwater welder. With the self-consuming technique, the electrode is dragged across the work and a significant amount of pressure must be applied by the diver. With the manipulative technique, the arc is held as it would be when welding on the surface and little or no pressure is applied to the electrode. The electrode can be maneuvered and manipulated by the diver. This method requires a great deal more skill and experience than does the self-consuming technique.

**3-12.1 Welding Set Up Procedures.** The following steps should be followed to establish optimum welding current and voltages.

- a. Before entering the water, set the amperage and run several beads on a plate.
- b. Use the tong test ammeter to check the amperage.
- c. After the diver enters the water, the first task is to clean a spot for the ground clamp. The spot should be in a position in front of the diver, as close as practical to the weld joint and should be scraped or wire brushed shiny clean. For diver safety, only C-type clamps should be used as grounding clamps for underwater cutting or welding operations. The clamp must be firmly secured to the work piece and the cable should have sufficient slack to prevent it from being pulled loose. The diver may elect to lightly tack weld the clamp in place when there is a possibility of it working loose. The ground should always be kept in the diver's forward line of vision.
- d. The diver should make a test weld to check the "heat" at working depth.
- e. Via the communications system, the diver can instruct the tender to fine tune the welding machine, that is; increase or decrease the amperage as

## S0300-BB-MAN-010

needed. The open circuit voltage may also require adjustment.

- f. After the optimum settings are determined, welding can begin.
- g. The diving tender should always maintain a written record of the following:
  - 1) The welding amperage as read from the tong meter.
  - 2) Both open and closed-circuit voltage as read from the volt meter.
  - 3) Electrode diameter, type, manufacturer and waterproofing material.
  - 4) Electrical polarity.
  - 5) Length of welding cable.
  - 6) Depth of work site.

By accurately recording this type of information, lessons may be learned and applied to future dives, thereby decreasing the likelihood of mistakes being duplicated.

**3-12.2 Self-consuming Technique.** When using the self-consuming technique, the weld metal is deposited in a series of beads or strings by dragging the electrode against the work. The technique is suited to fillet welding and can be readily adapted to underwater work since it provides a natural groove to guide the electrode. Tests have shown that the beads, when in the form of a fillet, result in welds having approximately the same leg length (size) as the diameter of the electrode used; that is, a single pass with a 1/8-inch electrode produces a fillet weld having a 1/8-inch leg.

**3-12.3 Fillet Welding in the Horizontal Position (Self-Consuming Technique).** In making fillet welds, pay particular attention to lead angles and work angles. The work angle is the angle between the electrode and the work in a plane at right angles to the long axis of the joint. The lead angle is the angle between the electrode and joint in the direction of travel. The following is the recommended procedure for fillet welding in the horizontal position:

- a. Make sure the safety switch is open.
- b. Thoroughly clean the surfaces to be welded.
- c. Set the welding power source to deliver the proper current for the electrode being used (see Table 3-3). This current is higher (0 to 30 percent) than the topside current for the same electrode since the surrounding water absorbs the heat rapidly.

## S0300-BB-MAN-010

- d. Hold the electrode against the plate at a work angle of  $45^\circ$  to the plate end surfaces as illustrated in [Figure 3-4](#). Tilt the electrode to a lead angle of  $45^\circ \pm 15^\circ$  in the line of intended weld. The angle variance, depends on the size of electrode used and the skill and technique of the diver.
  
- e. Call for SWITCH ON. The arc should start when the tender (phone talker) closes the safety switch. If the arc does not start, tap or rub the electrode tip against the work until the arc is established. Be sure to keep the electrode at the point where the weld is to begin. Once the arc is started, exert enough pressure against the work to allow the electrode to consume itself. Maintain the original work and lead angles between the electrode and line of weld by moving the hand perpendicularly toward the surface being welded (see [Figure 3-4](#)). Do not hold an arc as in topside welding, simply keep the electrode in contact with the work. Run straight beads; do not weave. About 8 inches of weld metal will be deposited for every 10 inches of electrode consumed. It is advantageous to use this method, especially when poor visibility makes it difficult to hold an arc in the usual topside manner.

## S0300-BB-MAN-010

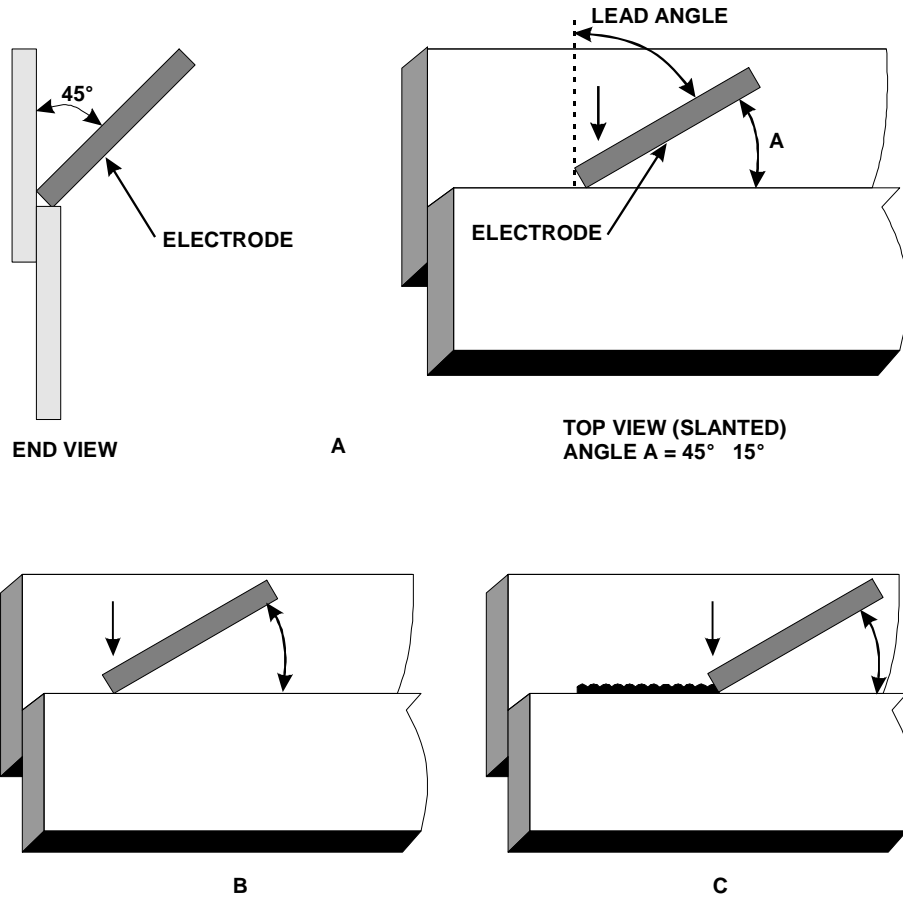

- A. POSITION THE ELECTRODE AT AN ANGLE OF APPROXIMATELY 30 DEGREES TO THE LINE OF WELD WITH THE ELECTRODE TIP IN CONTACT WITH THE WORK.
- B. CALL FOR SWITCH "ON." TAP THE ELECTRODE MOMENTARILY, IF NECESSARY, TO START THE ARC.
- C. APPLY SUFFICIENT PRESSURE IN THE DIRECTION OF THE ARROW TO ALLOW THE ELECTRODE TO CONSUME ITSELF.

**Figure 3-4. Self-Consuming Technique for Underwater Shielded Metal Arc Welding of Horizontal Fillet Welds.**

## S0300-BB-MAN-010

- f. When the electrode is consumed, break the arc, call for SWITCH OFF. Keep the electrode in welding position until the tender (phone talker) has confirmed switch off, then tap the electrode twice to make sure the switch is off. Only then proceed to change the electrode.
- g. Before starting to deposit a new weld, clean the previous weld thoroughly, especially the end where the arc was broken. Look for any visible pin holes or porosity which may affect the quality of the weld. Grinding is the best method as all slag, high points, lumps and any arc craters will be removed. The deposit from the new electrode should slightly overlap the previous deposit. All succeeding welds must be thoroughly cleaned and inspected for defects.
- h. Do not call for SWITCH ON until the new electrode is in position against the work and ready for welding. In general, try not to let the bubbles interfere with visibility when welding.

**3-12.3.1 Fillet Welding in the Vertical Position.** The self-consuming technique can also be used for fillet welding in the vertical position by following the same steps outlined above for horizontal fillet welding. The weld must start at the top and move down as shown in [Figure 3-5](#) so the bubbles generated will not interfere with the diver's visibility as he follows the line of the weld. Under certain conditions, it might be necessary to vary the lead angle of the electrode or adjust the current when welding in the vertical position.

**3-12.3.2 Fillet Welding in the Overhead Position.** The self-consuming technique can be applied to fillet welding in the overhead position ([Figure 3-6](#)) when using approved electrodes (see [Table 3-2](#)) and when the amperage is carefully adjusted. **THE AMPERAGE RANGE FOR OVERHEAD WELDING IS NARROW.** Welds deposited using current levels outside of this range will result in very poor deposits or no deposit at all. Good penetration and fusion can be obtained readily but undercutting and convex beads are difficult to avoid with this technique. Before attempting an actual overhead weld, the diver should make several practice runs under working conditions. These welds should be brought topside and examined to ascertain that the current setting is correct and that the diver has mastered the technique. Dripping beads indicate that (1) the current was too high, (2) the operator applied insufficient pressure or (3) both conditions were present. Skill, coupled with practice, is essential to the production of consistently good overhead welds.

The more experienced underwater welder can also use a modified self-consuming technique for overhead welding. The diver can vary the work angle from 35 to 55° while traveling down the line of the weld ([Figure 3-6](#)) maintaining slow, steady movement. With practice, overhead welds made this way will not have the undercutting and convexity which often result from using the standard self-consuming technique.



S0300-BB-MAN-010

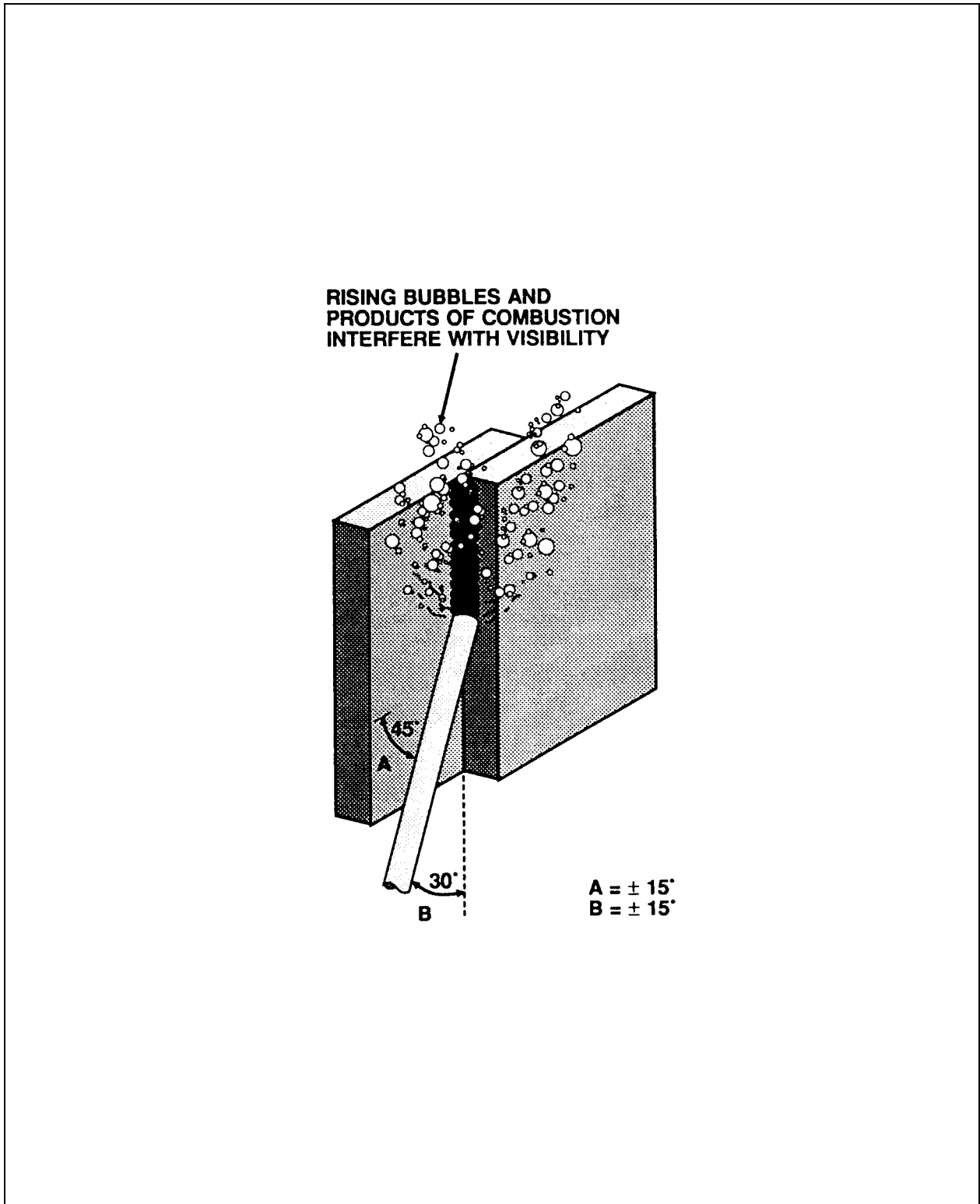
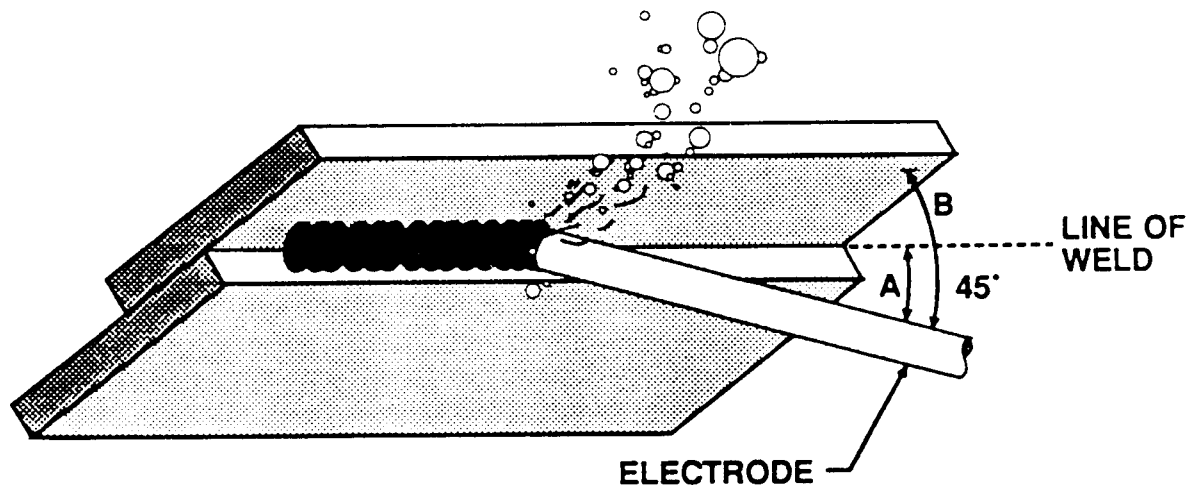

Figure 3-5. Self-Consuming Technique for Underwater Shielded Metal Arc Welding of Vertical Fillet Welds.

S0300-BB-MAN-010



ANGLE A = 15° TO 45° FOR SELF-CONSUMING TECHNIQUE  
ANGLE B = 35° TO 55° FOR "35°-55°" TECHNIQUE

Figure 3-6. Self-Consuming Technique for Underwater Shielded Metal Arc Welding of Overhead Fillet Welds.

## S0300-BB-MAN-010

**3-12.3.3 Self-Consuming and Manipulative Techniques.** The self-consuming technique is recommended for divers of average or less than average skill who have little time for practice. Naturally, the self-consuming technique does not produce as strong a weld as does one laid down by a skilled underwater welder using the manipulative technique. However, for salvage purposes, sound welds made using the self-consuming technique are considered acceptable. The manipulative or weave technique and the 35° to 55° self-consuming techniques are recommended for skilled operators only.

**3-12.3.4 Fillet Welding Where There is Poor Fit-Up.** Where there is poor fit-up of members or plates to be welded, additional weld metal is needed to fill the gap at the root of the fillet. This can be done by feeding in the electrode toward the joint faster than it is usually fed in when using the self-consuming technique. Approximately 6 inches of weld for 10 inches of electrode can be deposited instead of the usual 8 inches of weld by feeding in. When this technique is used underwater, the additional weld metal laid in the opening solidifies rapidly as shown in [Figure 3-7](#); it does not run out of the gap as it would in the air. Fillets with gaps at the root up to 1/8 inch have been successfully welded using this process, although it is not recommended for use on thin metals. [Paragraph 3-12.4.](#) addresses welding on thin metals.

Do not attempt to bridge a gap greater than 1/8-inch with weld metal. This will result in a cracked weld bead which will eventually have to be removed. The correct procedure is to run successive stringer beads on the continuous member until the gap is less than 1/8-inch. Then bridge the gap to join the members.

**3-12.4 Welding on Thin Plates.** The techniques for welding plates, which are 20-gauge or less, are basically the same as those described above. However, the following practices are required in order to successfully complete the weld and prevent the electrode from burning through the metal.

- a. The maximum electrode size shall be 1/8-inch.
- b. Maximum travel speed and minimum amperage should be used consistent with depositing a sound weld bead.
- c. Minimum electrode pressure is essential.
- d. Electrodes must be properly manipulated to avoid overheating a specific area.
- e. When welding a thicker material onto a thinner material by using manipulative or self-consuming technique, the majority of the heat should be directed toward the thicker metal. Ultrasonic equipment may be used to determine the actual thickness of the base metal to be welded.
- f. The arc should always be struck on previously deposited weld metal or on thicker metal.

S0300-BB-MAN-010

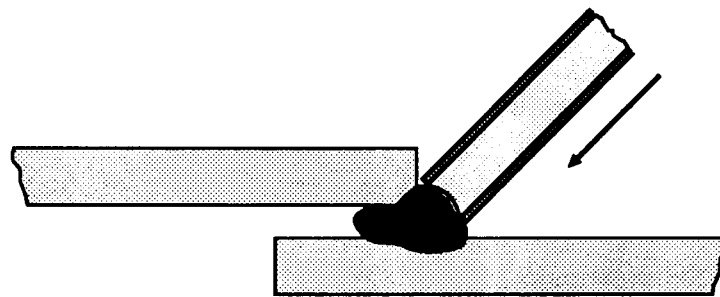

(a). SIDE

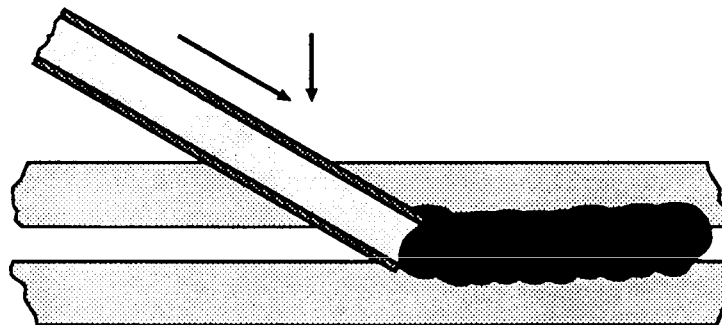

(b). FRONT

**PRESSURE APPLIED IN THE DIRECTION OF THE ARROWS  
TO DEPOSIT ENOUGH FILLER METAL TO FILL THE GAP**

**Figure 3-7. Feeding-In Technique for Underwater Shielded Metal Arc Welding of Fillet Welds in Wide-Gap Joints.**

## S0300-BB-MAN-010

- g. The arc should always be broken by pulling back on the previously deposited metal.
- h. It is always good practice to establish proper heat and travel speed on practice material of thickness equivalent to the base metal of the intended weld and under similar conditions.

### 3-13 PROCEDURE FOR REPAIRING SMALL CRACKS

Preparation is the key to stopping crack propagation. Attempts to stop a crack by filling in with weld metal most often result in failure as the crack is very likely to open up again through the weld. Therefore, small patches, preferably circular ones, are recommended. These patches can be readily attached to the hull of a ship by fillet welding because the groove of the fillet provides a guide for depositing the electrode.

The following procedures are recommended:

- a. Locate the ends of the crack by appropriate non-destructive testing techniques; Ultrasonic Testing (UT) or Magnetic Particle (MT).
- b. Drill small holes at the extreme ends of the crack to prevent further crack development. Alternatively, the holes may be burned.
- c. An area of approximately 2 inches should be scraped or wire brushed shiny clean around the crack where the patch is to be fixed. Prepare the patch, to extend beyond the crack 6 inches in all directions. Contour the patch as necessary to fit the work.

**3-13.1 Using a Rectangular Patch.** The following procedure is recommended for repairing cracks in underwater structures using a rectangular patch. [Figure 3-8](#) illustrates this procedure.

- a. Round the corners of the rectangular patch using a 3-inch radius.
- b. Place the patch over the crack and attach by fillet welding. To allow for venting, do not weld the uppermost 3-inch section of the patch during the root pass.
- c. Turn the patch on a 45° angle, if necessary, to reduce the need for overhead welding.

**3-13.2 Using a Circular Patch.** The following procedure is recommended for repairing cracks in underwater structures using a circular patch. [Figure 3-9](#) illustrates this procedure.

S0300-BB-MAN-010

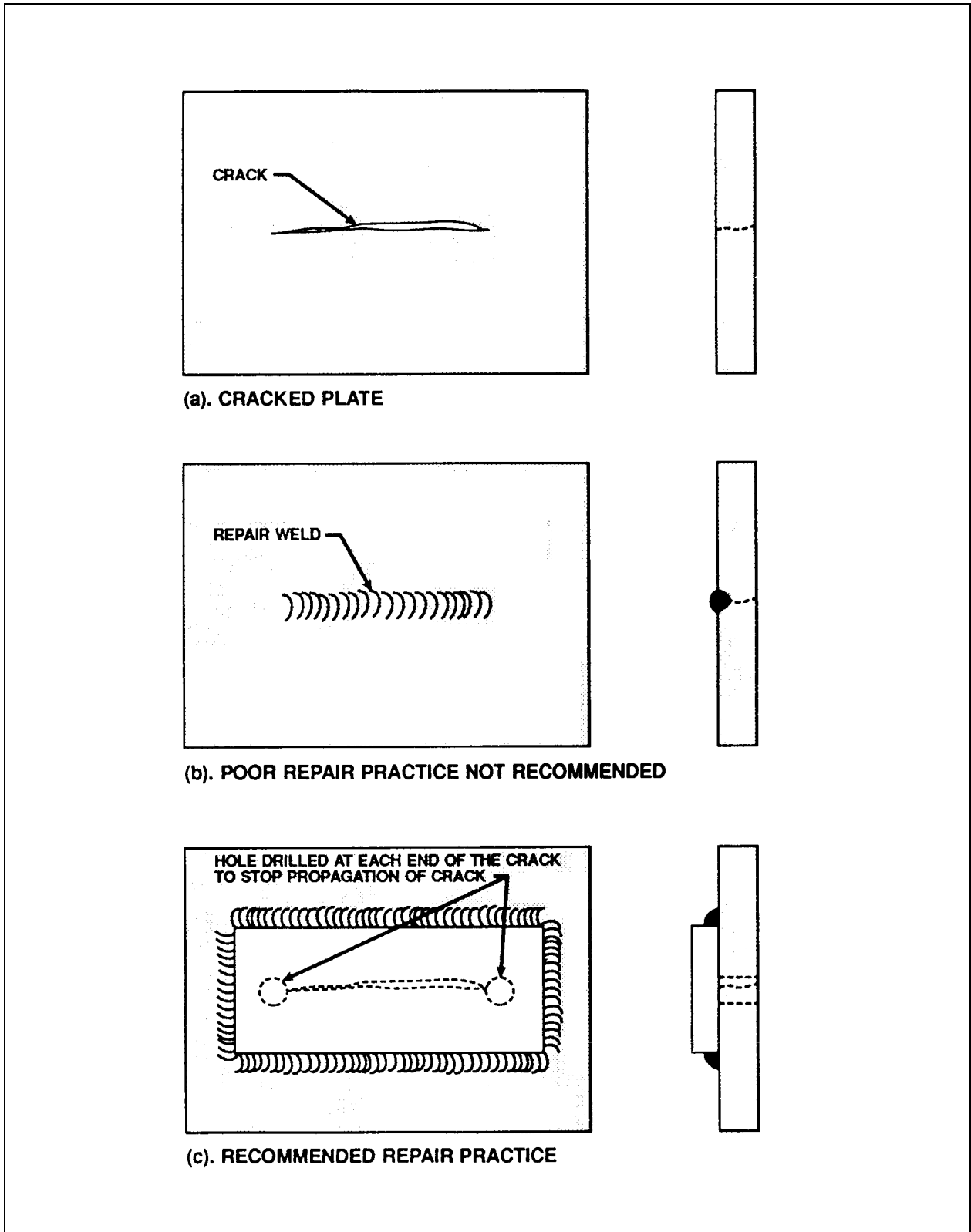

Figure 3-8. Repair Method for Cracks in Underwater Structures Using a Rectangular Patch.

S0300-BB-MAN-010

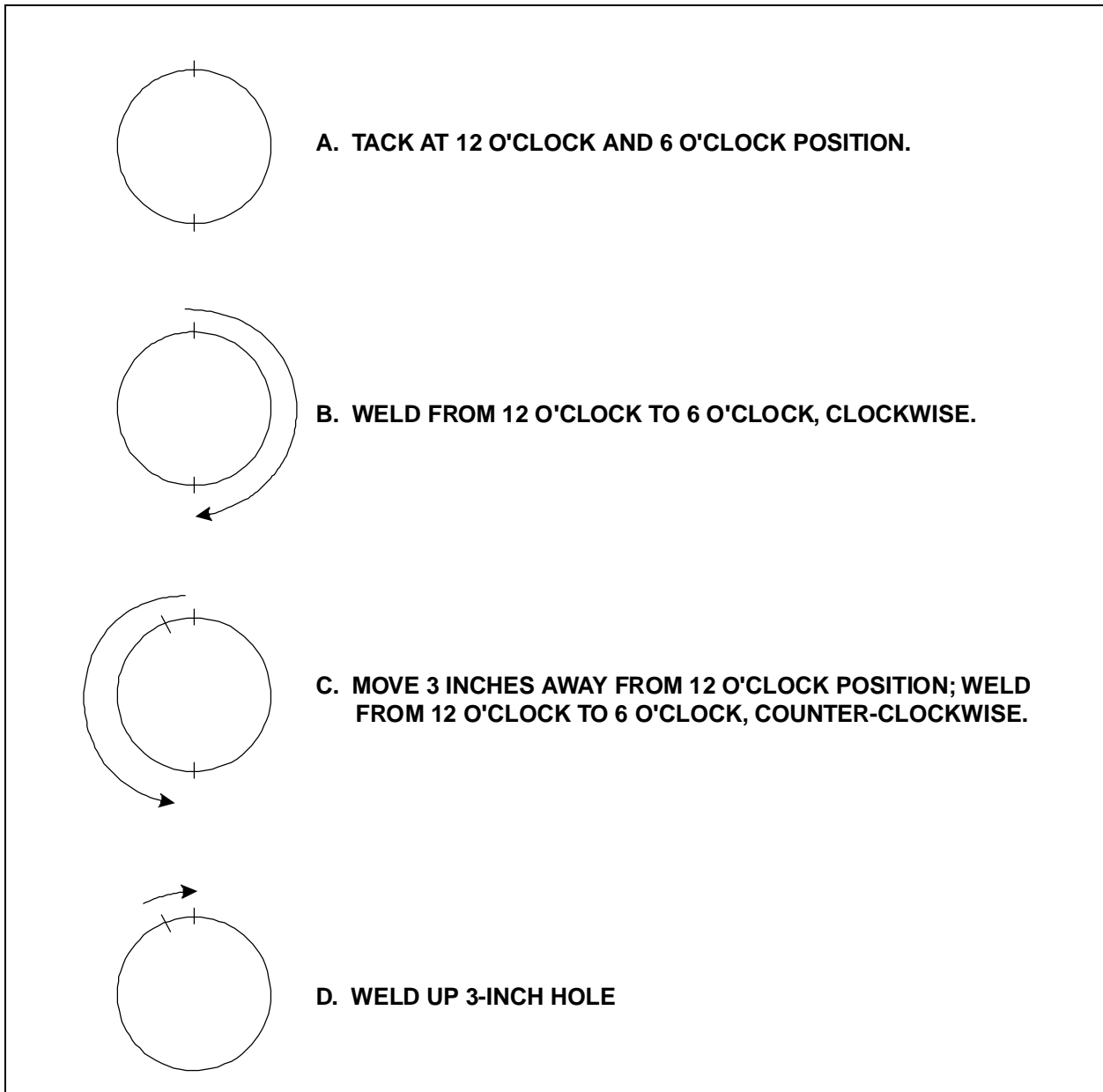

Figure 3-9. Repair Methods for Cracks in Underwater Structures Using a Circular Patch.

### S0300-BB-MAN-010

- a. Tack the patch on at the 12 o'clock position, tap it down and tack it on at the 6 o'clock position. Then tack at the 3 and 9 o'clock positions.
- b. Clean the slag from the tacks and grind all tack ends to a feather edge.
- c. Begin welding downhill at the 12 o'clock position. Weld clockwise to and including the tack at the 6 o'clock position.
- d. Return to the 12 o'clock position and move approximately 3 inches away from the previous weld. Then weld downhill counter clockwise to the 6 o'clock position.
- e. To finish, weld the remaining 3 inches at the top. Clean the entire weld bead and fill in any incomplete tie-ins. Additional passes are required to obtain the mandatory 3/8-inch leg length. Always completely de-slag previous beads before welding.

### **3-14 POST-DIVE MAINTENANCE**

After each use, rinse the electrode holder in fresh water and dry it. Disassemble and inspect metal parts for corrosion damage due to electrolysis. Replace any damaged parts (see [Figure 3-10](#)). All equipment should be thoroughly dry before storing. Store all equipment, including electrodes, in an oil-free environment.



S0300-BB-MAN-010

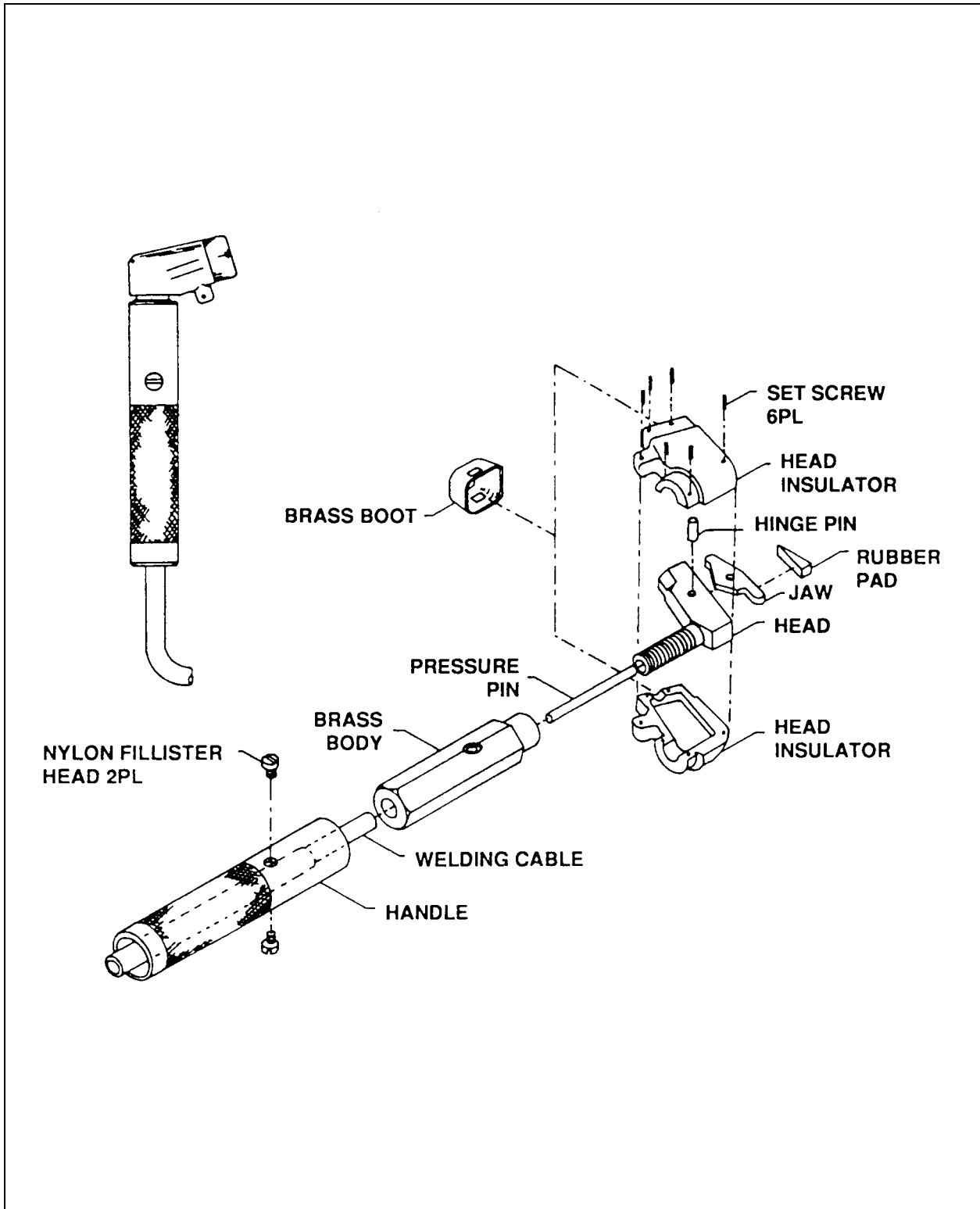

Figure 3-10. A Typical Underwater Welding Electrode Holder.

---

## CHAPTER 4

---

### UNDERWATER ARC CUTTING AND WELDING EQUIPMENT

#### 4-1 INTRODUCTION

This chapter presents information concerning underwater cutting and welding technology and the equipment necessary to conduct such operations. Included are discussions on the required equipment and equipment set up procedures. This information will be particularly useful during the planning and staging phase of an operation. Because no two underwater operations are exactly the same, each must be regarded as unique. The planning, preparation and execution of the underwater cutting or welding operation must be carefully worked out for each job. To aid in planning operations, tables listing the recommended equipment for a particular job, commercial vendor information and appropriate specifications are included. Only approved equipment shall be used, except in exceptional situations (see [Appendix E](#)).

#### 4-2 EQUIPMENT USED FOR UNDERWATER ARC CUTTING AND WELDING

**4-2.1 Oxygen-Arc and Shielded Metal Arc Equipment.** Underwater oxygen arc cutting and shielded metal arc cutting and welding are performed with basically the same equipment. A typical arrangement of this equipment is illustrated in [Figure 4-1](#); additional accessories not shown include scrapers and wire brushes which are used for both underwater cutting and welding operations. The equipment is also listed in [Table 4-1](#).

**4-2.2 Diving Equipment.** The standard Navy MK 1, MK 12 or Superlite-17 helmets will be used while conducting underwater cutting or welding operations. These helmets have wide fields of view and a welding shield can be attached, as shown in [Figures 4-2, 4-3 and 4-4](#).

Specific technical information necessary to operate the diving equipment is addressed in Operation and Maintenance Instructions for the MK 1, Mod “0” Lightweight Diving Outfit (NAVSEA SS520-AE-MMA-010/ DIV OST); for the MK 12 SSDS (NAVSEA 0994-LP-018-5010); for the Superlite 17b-Mod “0” Helmet (S6560-AG-OMP-010/SL17B/NS-DS118B); or, for the Superlite 17B-Mod “1” Helmet (S6560-AG-OMP-010/SL17B/NSI).

**4-2.2.1 Welding Shields.** The MK 12 welding shield is secured to the helmet by two spring clips which hook to the forward edge of the side viewport retainers. A rubber cushion on the rear of the shield body helps to hold it in place. The lens is clip-mounted in a hinged section. The hinged section can be flipped up or down and is held in position by a flat detent spring. The replaceable lenses, made of gold foil laminated with polycarbonate, are supplied in #4, #6 and #8 commercial shades of light density. Darker shades are available but are seldom required.

Close up views of the welding shields with parts identification are illustrated in [Figures 4-5 and 4-6](#).

S0300-BB-MAN-010

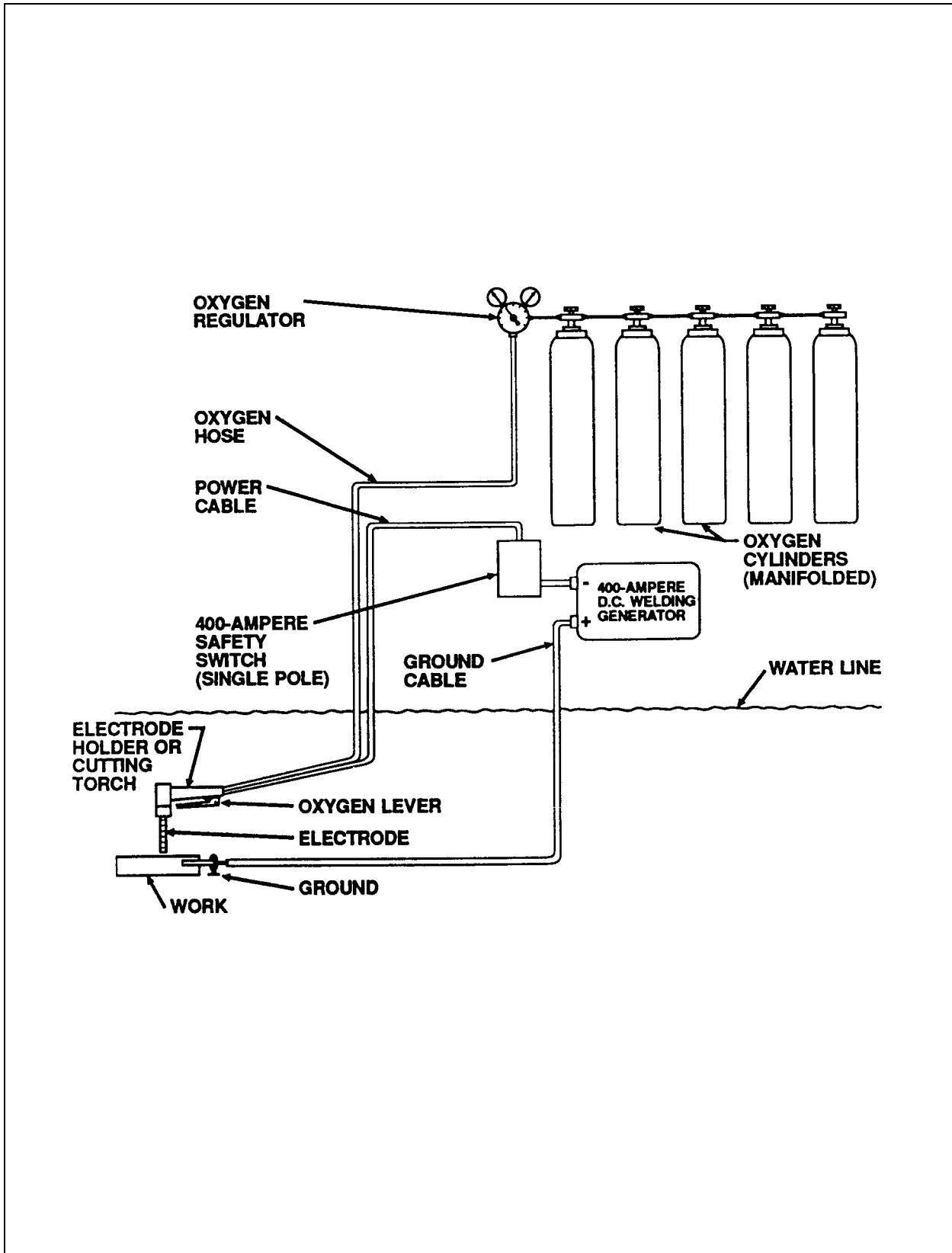

Figure 4-1. Typical Arrangement of Underwater Arc Cutting Equipment.

S0300-BB-MAN-010

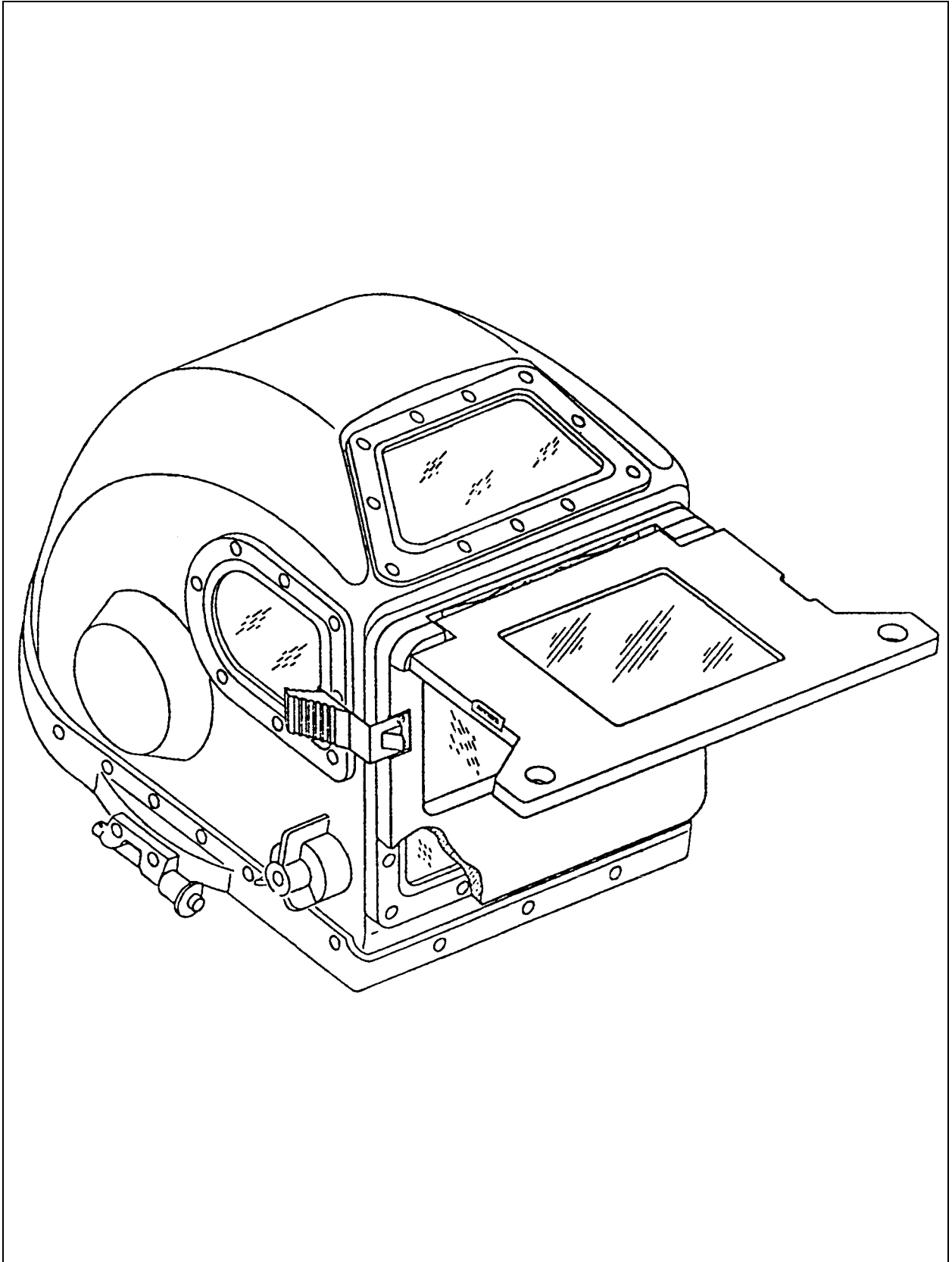

Figure 4-2. MK12 SSDS Welding Shield.

S0300-BB-MAN-010

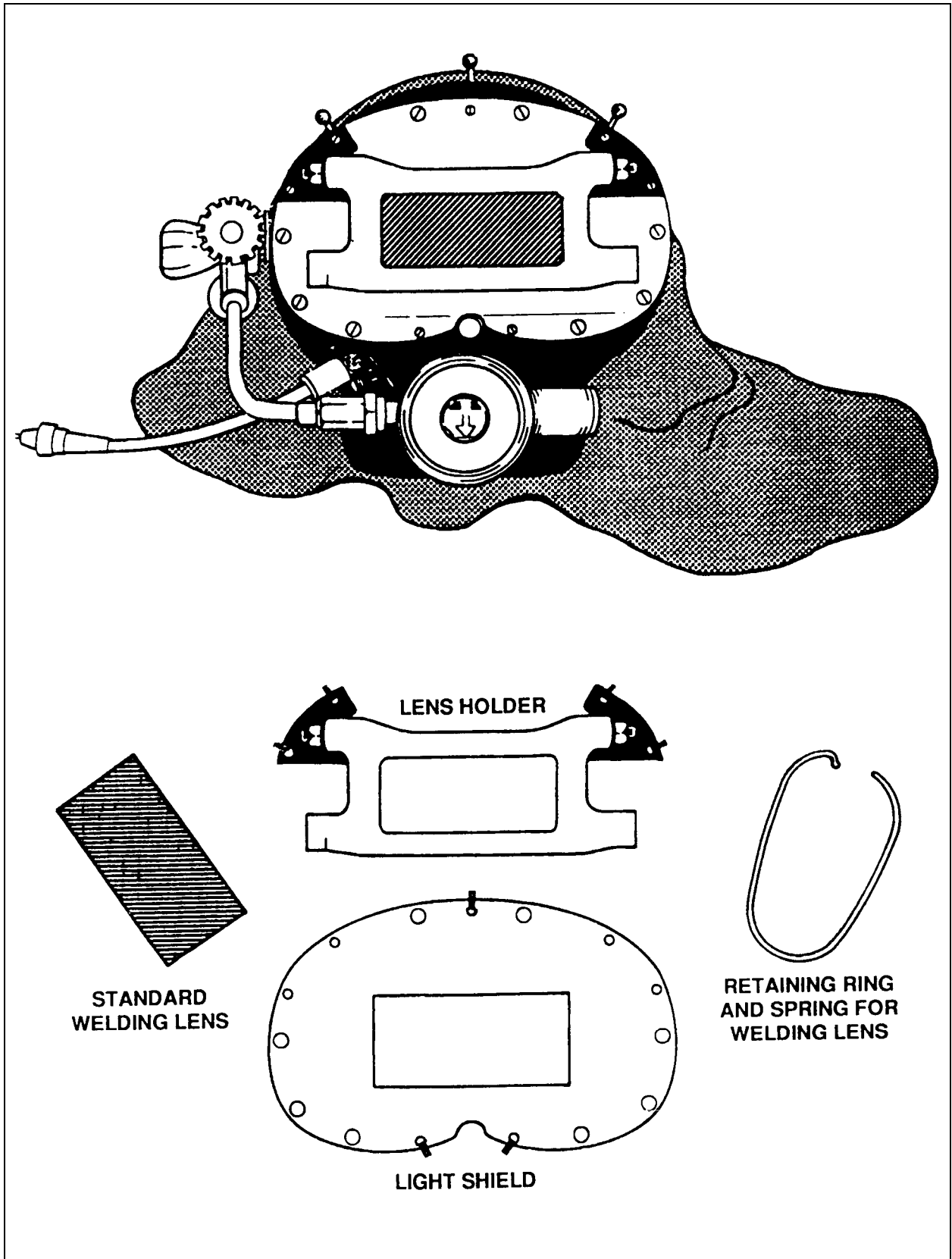

Figure 4-3. MK1, MOD 0 Mask and Lens Holder Assembly.

S0300-BB-MAN-010

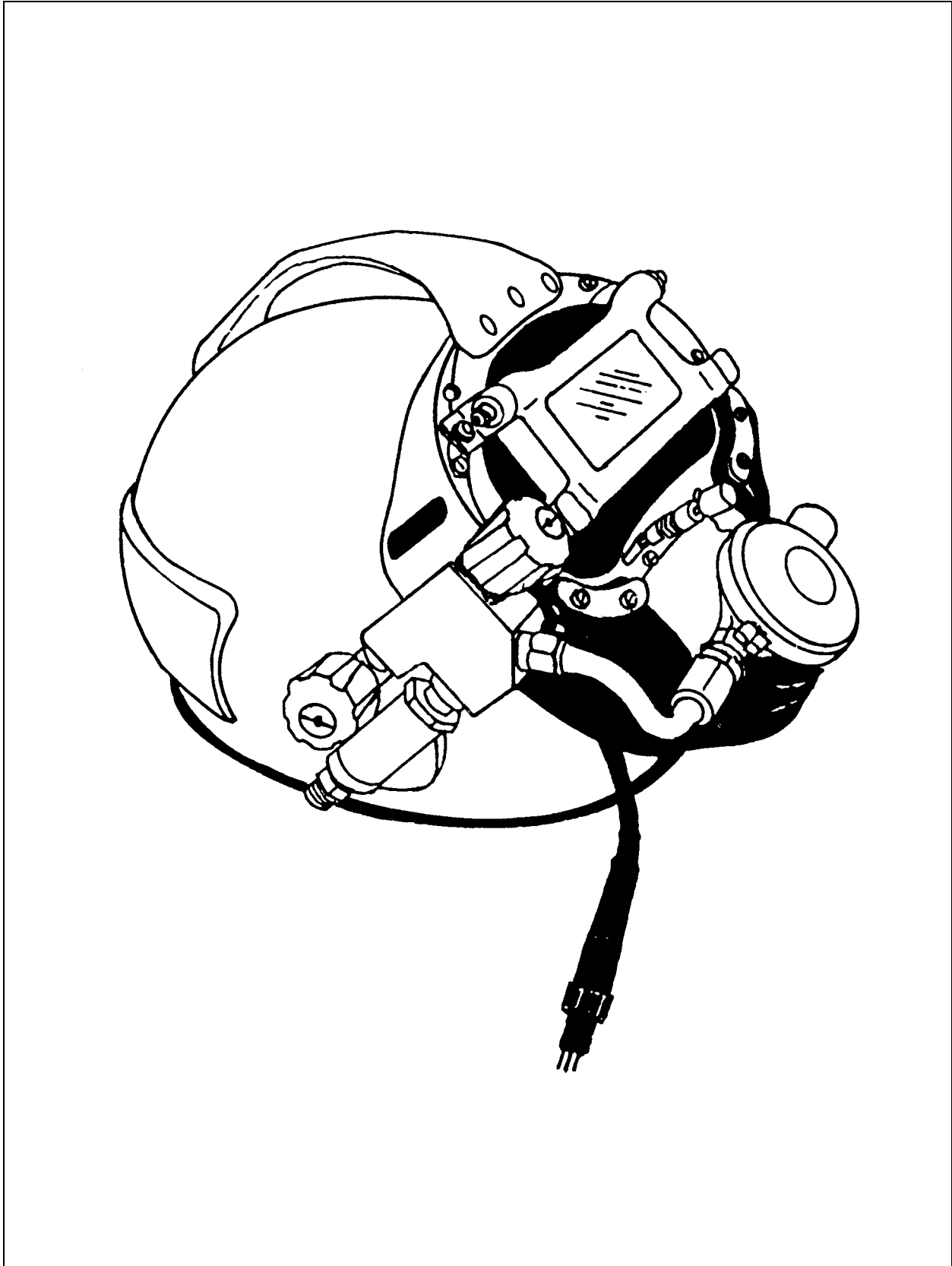

Figure 4-4. Superlite-17B/NS Helmet and Lens Holder Assembly.

S0300-BB-MAN-010

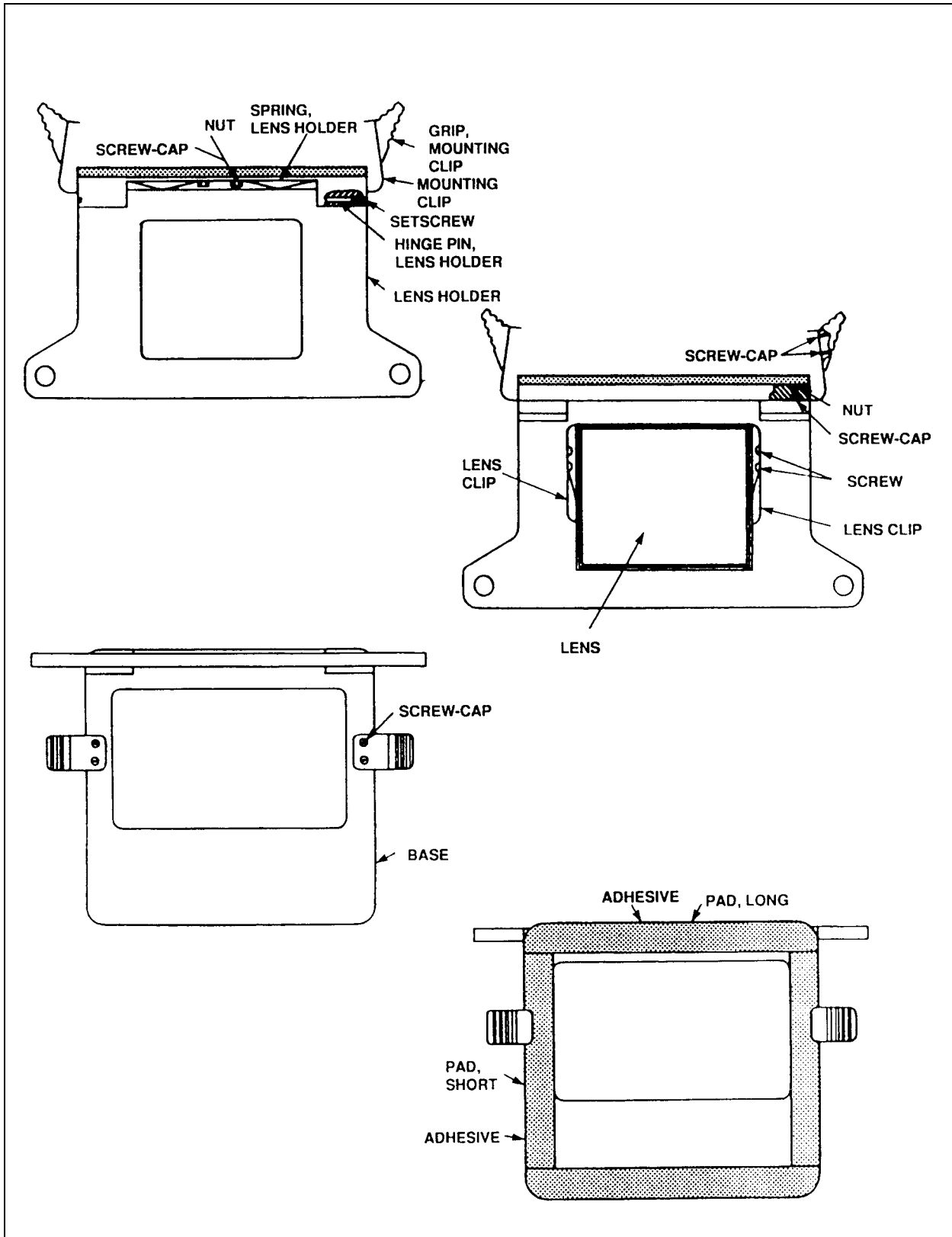

Figure 4-5. MK 12 Helmet Lens Holder Assembly with Parts Identification.

S0300-BB-MAN-010

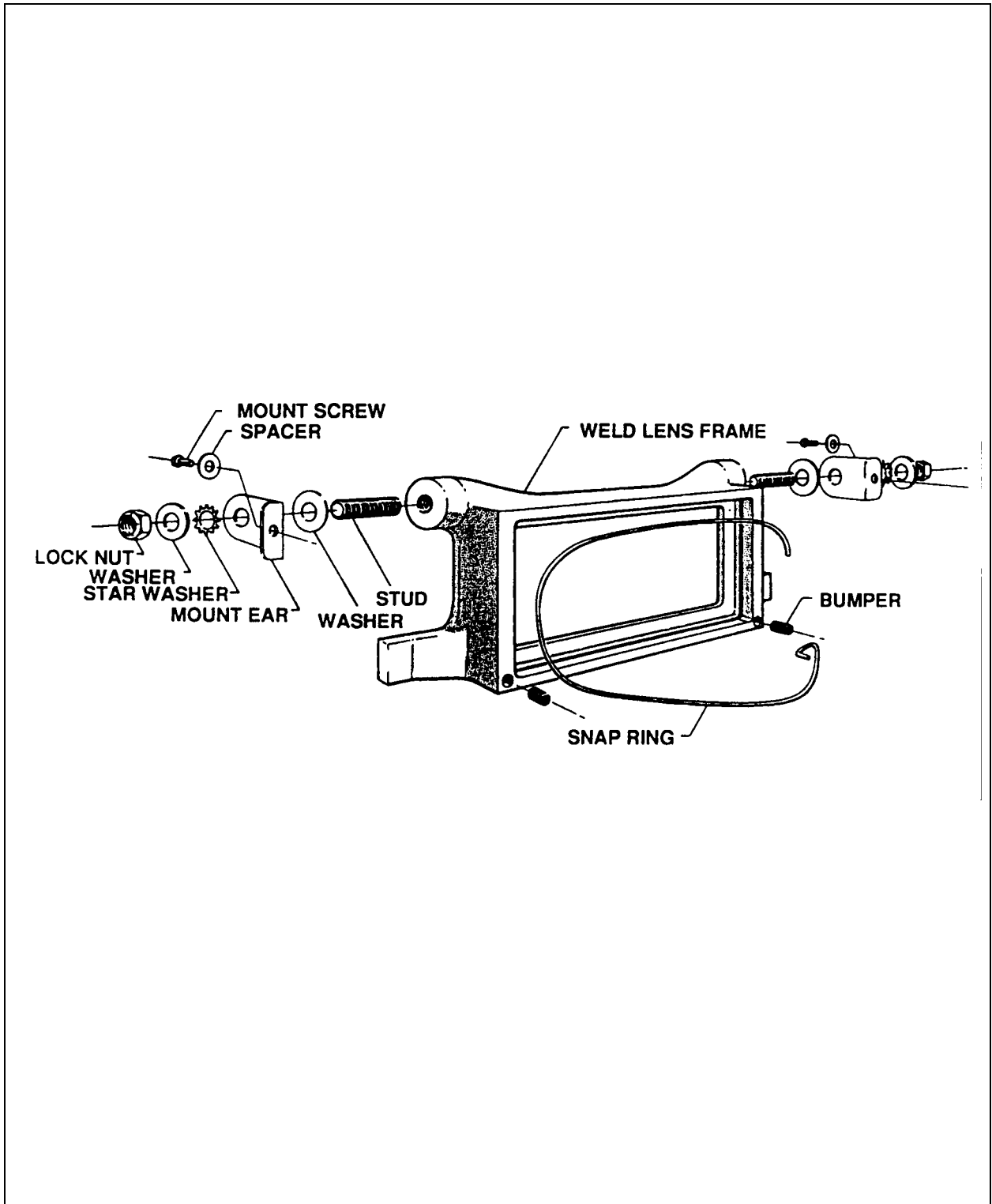

Figure 4-6. Superlite-17B/NS Welding Lens Holder with Parts Identification.



S0300-BB-MAN-010

**Table 4-1. Recommended Equipment for Underwater Arc Cutting and Welding**

Category	Item
Diving equipment	MK 12, MK 1 or Superlite 17B Surface Supported Diving System with Welding shield and assorted welding lens Heavy-duty rubber gloves and Playtex-type or surgical gloves Communications System
Cutting and welding equipment	DC welding power source 400 amperes Safety switch rated at 400 amperes, 250 volts Welding cables, sizes 1/0 and 2/0 with bolt-together cable connectors and necessary bolts and nuts "C"-type ground clamp Amperage tong meter Electrician's DC volt meter
Cutting equipment	Underwater cutting torches Oxygen hose Manifold to connect the cylinders; if more than one is to be used 2-stage, high flow, high volume regulator Leak detector - LEAK-TEC or soap suds
Welding equipment	Electrode holder Weighted wire brush Chipping hammer Scraper Ultrasonic thickness and flaw detection device Dye Penetrant test kit

## S0300-BB-MAN-010

Specific technical information necessary to operate diving equipment is addressed in the appropriate surface supported diving system technical manual.

**WARNING**

AC power shall not be used for underwater cutting or welding due to the extreme danger involved with AC current underwater. Electrical shock produced by AC current prevents voluntary relaxation of the muscles controlling the hand. Consequently, the diver may be unable to let go if his body or equipment accidentally enters the electrical circuit.

**4-2.3 Power Supply Requirements.** The preferred power supply for underwater cutting and welding is a 400 amp or larger, engine driven DC welding generator with a minimum of 60 percent duty cycle. The generator shall have independent voltage and amperage controls. [Figure 4-7a](#) shows control panel of a typical generator. A welding power source with a minimum capacity of 300 amperes is acceptable, however, cutting time is considerably longer whenever power is reduced. 400 amp and over are required for some operations. DC generators, motor generators and rectifiers are acceptable power supplies. In an emergency, a 200-ampere machine set for peak or near-peak load may be sufficient for short periods of time; rectified or motor driven type machines may also be used.

**4-2.3.1 Power converters.** Power converters are just what the name implies; the input alternating current (AC) primary power is passed through a circuit breaker to a rectifier, where the input is transformed to DC power. Portable power converters, though somewhat limited, are particularly useful for salvage work when ship or shore power is available. [Figure 4-8](#) shows one such unit which weighs only 70 pounds and will deliver a maximum of 80 volts open circuit with an adjustable current range of 30 to 375 amps. Power converters should not be used when the work is deeper than 100 FSW or with more than 200 feet of welding lead. To work beyond these boundaries would overwork the machine. This type machine will support cutting operations using the exothermic technique for short periods of time, however, for long burning jobs where power is to be used, a welding generator is recommended. This type of unit will not accommodate cutting operations using the steel-tubular electrode. When using electric-driven machines, ensure that the primary power supply cables are laid separately and away from welding supply cables.

Motor generator power sources consume large amounts of energy during their entire running period. A welding rectified power supply will require significant energy only during the welding cycle. This may be an important consideration when away from normal logistic support.

S0300-BB-MAN-010

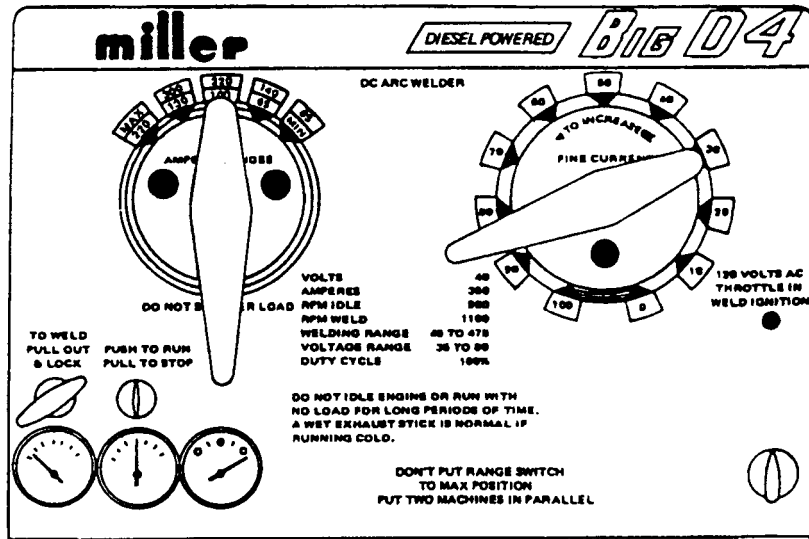

a.

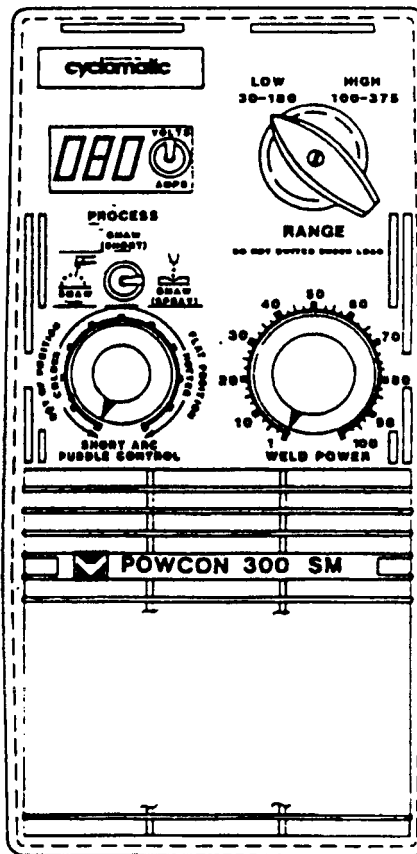

b.

Figure 4-7. Typical Welding Generator and Power-Converter Control Panel.

## S0300-BB-MAN-010

**4-2.3.2 Welding Generator, Pre-Setup Inspection.** Successful underwater welding and cutting is highly dependent on the efficient running of the power supply unit. Before any underwater work takes place, the welding power source should be fully inspected by qualified personnel. The commutators on motor-generators should be clean. Brushes must not be excessively short or worn. Slack brush rigging springs must be replaced. Operation of a welding generator beyond its capacity and duty cycle will melt the soldered rotor winding connections to the commutator. This will reduce the generator's capacity during future use. If the generator is incapable of achieving rated capacity for its duty cycle, then the interior of the housing should be checked for traces of soldered deposits. All power sources should be checked for confirmation of rated capacity before use. Motor generators designed solely for use with semi-automatic welding equipment are not suitable for underwater applications.

[Table 4-1](#) lists the equipment required for underwater cutting and welding.

**4-2.3.3 Polarity.** Underwater cutting and welding operations are usually performed with DC ELECTRODE NEGATIVE, i.e., STRAIGHT POLARITY. A typical equipment arrangement is illustrated in [Figure 4-8](#). The cable from the electrode holder is connected to the negative (-) terminal of the DC power supply and the positive (+) or ground cable is connected to the work. The majority of electrode manufacturers call for a DC, ELECTRODE NEGATIVE setup. Occasionally, there may be a requirement for reverse polarity, sometimes referred to as DC, ELECTRODE POSITIVE for a particular electrode or for improved welding as noted in [Chapter 3](#). This will normally be at the recommendation of the electrode manufacturer and will be printed on the electrode box or included in accompanying literature.

**4-2.3.4 Polarity test.** When the polarity of a welding generator is uncertain; i.e., the terminals are unmarked or not legible, it is necessary to determine the polarity before proceeding with welding or cutting operations.

The procedure for the test is as follows:

- a. With the power source dead, connect the ground and welding leads to the terminals.
- b. Attach a small, plate to the ground cable; place an electrode in the electrode holder or cutting torch as applicable.
- c. Personnel performing this test must be properly insulated from the current.
- d. Immerse the plate and the tip of the electrode in a container of salt water and hold them about 2 inches apart.
- e. Call for "Switch on," and one of the following will occur:
  - 1) A heavy stream of bubbles will rise from electrode tip. This indicates straight polarity, that is: DC, ELECTRODE NEGATIVE (-). Label the terminals on the welding machine.

S0300-BB-MAN-010

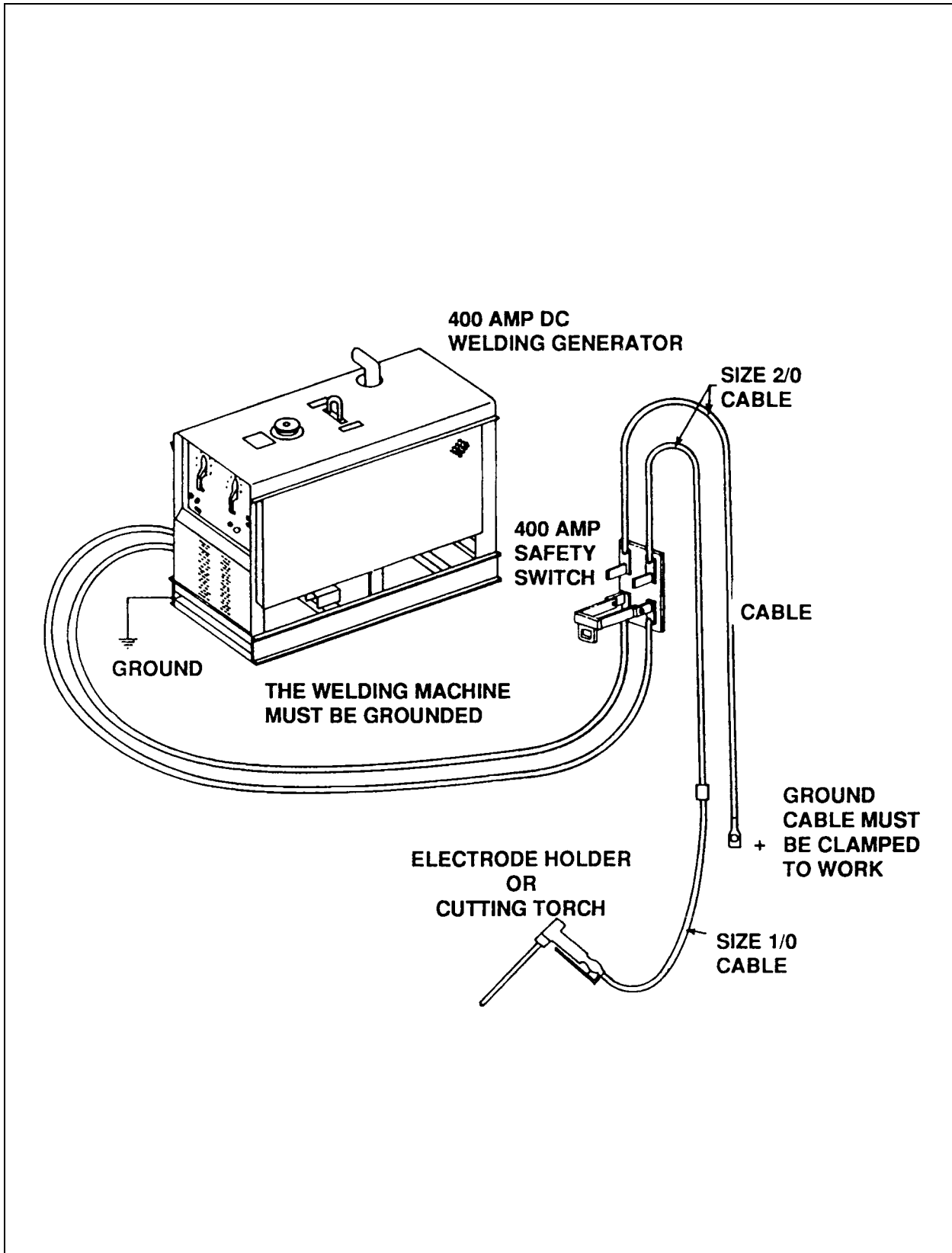

Figure 4-8. Equipment Arrangement for Welding and Cutting Straight Polarity.

## S0300-BB-MAN-010

- 2) If bubbles appear from the plate, switch off the current and change the lead connections to the opposite terminals. Repeat test and label the machine terminals for future reference.
- f. Once the correct polarity is determined, the ground clamp should then be bolted to the POSITIVE (+) lead and the electrode holder attached to the NEGATIVE (-) lead.

**4-2.3.5 Tong Test Ammeter.** The Tong Test Ammeter is a portable instrument that will measure current flowing in a circuit without making electrical connections to it. It is a most important tool to have on hand while setting-up for and during underwater cutting and welding operations. This is especially true when there is uncertainty as to the output of a particular welding machine. Costly mistakes and wasted bottom time may be avoided by simply taking a Tong reading before the diver enters the water. This step will eliminate any doubt as to the actual welding generator amperage output. There have been many holes burned in ship's bottoms by divers who assumed the welding machine was functioning properly when in fact it was delivering amperage far in excess of the dial setting. On the other hand, there have been many man-hours wasted by divers trying to weld or burn with too little amperage.

To determine the exact amperage output of the welding generator, take a tong meter reading. Wait until the diver has established an arc and is welding and simply encircle the welding lead with the tongs of the test ammeter and close them. A clear, accurate reading will instantly register on the scale. This will be the closed-circuit reading. The tongs open by a slight pressure of one finger on the trigger and are self-closing (see [Figure 4-9](#))

Do not rely exclusively on the values indicated by the control panel knobs or on installed meters. The meters are not intended for exact current or voltage measurements. The tong test ammeter will read the actual current passing through the welding cable.

**4-2.3.6 Amperage and Voltage.** An understanding welding of electricity and of the interrelationships of amperage and voltage is important for the diver involved with underwater cutting and welding. An electrical arc welding circuit is the same as any other electrical circuit. There are three factors in a simple electrical circuit:

- a. Current — flow of electricity
- b. Pressure — force needed to effect current flow
- c. Resistance — force used to regulate the flow of current

Current is a “rate of flow.” Current is measured in amperes. The term ampere is the amount of current that flows through a circuit per second. Amperage is also the current that provides the heat necessary to melt the base metal.

Pressure is the push or force that causes the current to flow. The measure of pressure is the volt. Voltage measured in machine out-put and across an arc are essentially the same. Before the arc is struck or if the arc is broken, the voltmeter will read the voltage across the

S0300-BB-MAN-010

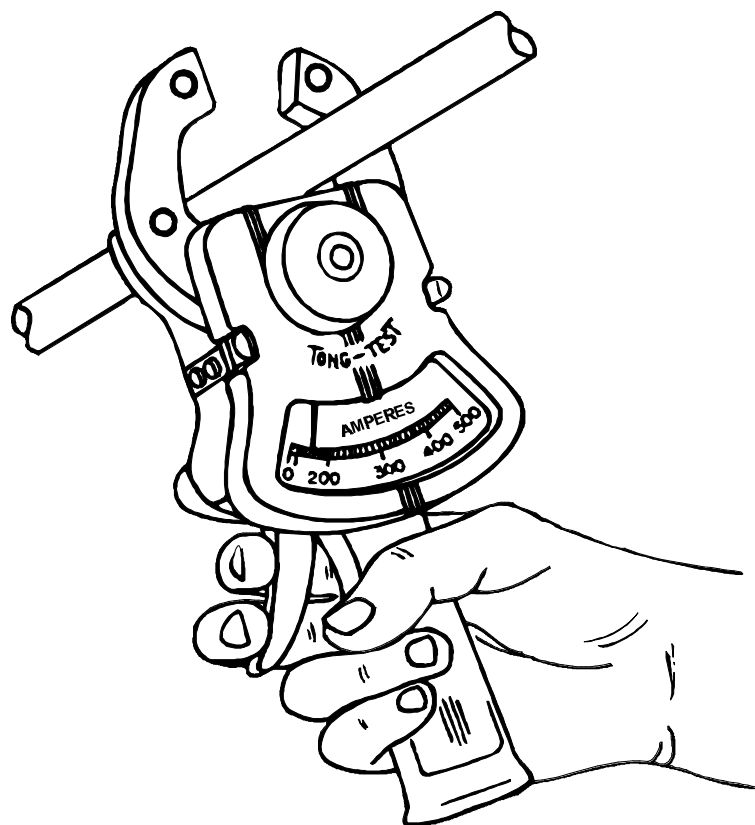

Figure 4-9. Tong Test Ammeter.

## S0300-BB-MAN-010

machine with no current flowing in the circuit. This is known as the open circuit voltage and is higher than arc voltage when current is flowing (closed circuit voltage, also referred to as arc voltage).

Resistance is a restriction to current flow in an electrical circuit. Every component in the circuit, including the conductor, (welding and ground leads) offers resistance to current flow. Current flows through some conductors easier than others. Resistance depends basically on the material and the thickness (cross sectional area) of a conductor. Welding leads are made of copper since it has the lowest electrical resistivity of common metals.

There are a number of variable factors affecting welding machine settings. These include size and type of electrode, thickness of metal to be welded, type of joint and the skill and technique of the diver. Current ranges as published by assorted manufacturers vary considerably for the same classification and size of electrode. The underwater welding or cutting operation should be started using the settings listed in [Tables 2-1](#) and [3-3](#) and adjusted as necessary to produce the desired effect.

**4-2.3.7 Diesel Driven Welding Generator Amperage and Voltage settings.** In addition to setting up for the desired polarity, the machine must also be set for the correct amperage and voltage. Setup procedures for welding machines vary according to the type of machine and according to the manufacturer. Therefore, the manufacturer's operating manuals and instructions for the particular machine should be consulted and closely followed.

Most diesel driven welding generators have two control dials, one for adjusting desired amperage and one for voltage adjustment. There are several types of welding generators in use throughout the Navy and the commercial industry. The overall functions and operating setup are essentially the same.

**CAUTION**

Arcing can damage welding machine switch contacts. Do NOT change the Range Switch position while welding or under load. Arcing causes pitting and will eventually render the contacts inoperative.

The dial on the operator's left is the Amperage Range or Course Amperage Control. The range of each switch position is displayed on the nameplate. The amperage range is set before welding begins and is not to be adjusted while actual welding is in progress. The dial on the right is the Fine Adjustment Control and selects a welding amperage and open-circuit voltage between the minimum and maximum values of the coarse range selected by the Range Switch. The scale surrounding the Fine Adjustment control is calibrated in percent and does not indicate an actual amperage value. The Fine Adjustment control may be adjusted while welding. The procedure is:



## S0300-BB-MAN-010

EXAMPLE: Setting up a Typical Welding Generator.

With the Amperage Range set at the 100 to 220 position and the Fine Adjustment set at 0 percent, the welding generator would produce 100 amps and 24 to 26 closed-circuit volts. By moving the Fine Adjustment to the 35 percent position, the generator would produce 140 amps and 28 to 30 closed-circuit volts. Should more closed-circuit voltage be desired with the same amperage, the Amperage Range can be moved to the 65 to 140 range and the fine current adjusted to the 100 percent position. This arrangement would cause the machine to produce 140 amps and 34 to 36 closed-circuit volts. This setting is often chosen to produce smoother beads, less arc blow and better penetration, however it can increase undercutting due to the increased voltage (pressure). Notice that the Amperage Ranges overlap. This allows amperage and voltage adjustment throughout the machines range.

**4-2.4 Safety Switches.** A safety switch, also referred to as “knife switch” and disconnect switch, is required in the electric circuit to protect the diver from electric shock when not cutting or welding. A typical four-pole safety switch used with underwater cutting and welding equipment is shown in [Figures 4-1](#) and [4-8](#). When a single-pole knife switch is used, it should always be located in the welding-lead side of the electric circuit and must be rated to handle the maximum welding current. Additionally, the safety switch must be mounted vertically on a non-conducting (wood, plastic, etc.) stand. The safety switch has an open circuit potential of some 80 volts across the poles. To prevent accidental contact, the switch should be fitted with a non-conducting slotted cover.

The use of an approved, positive-acting safety switch in the welding or cutting-circuit is mandatory. The switch must be mounted so the handle is in the upper-most position during welding or cutting. If the switch should accidentally fall, the circuit is broken. The switch illustrated in [Figure 4-8](#) shows the correct orientation. The safety switch protects the diver by allowing current flow only when the diver is actually cutting or welding or has the electrode poised and ready. When a single-pole switch is used, special care must be taken that the switch is not being shunted out or bypassed. This can occur if there is a break in the insulation between the welding machine and the safety switch. It is important to remember that wet, bruised or worn cables between the machine and the switch, either single or double pole, can be shorted out by abrading against the frame of the welding machine, hatch combings or lying on a steel deck. Cables in this condition would constitute a potential source of danger.

**4-2.5 Power Cables and Connectors.** The proper cable size for a particular job depends on the total length of circuit. Size 2/0, extra-flexible welding cable is recommended for work that is a considerable distance from the power source, because the voltage drop is less due to its lower resistance. It should be used where the total length of cable, including the electrode and ground leads, exceeds 300 feet. Where the total length of the leads exceeds 400 feet, 3/0 size cable should be used to reduce resistance. The length of cable attached to an electrode holder, sometimes referred to as the whip lead, may be size 1/0, extra-flexible cable. This will enable the diver to easily maneuver the electrode holder as he welds.

## S0300-BB-MAN-010

Each additional length of cable and its connectors produce a voltage drop. To prevent excessive voltage-drop in the welding or cutting leads, it is desirable to have various lengths of continuous lead on hand. Welding lead procured in lengths of 50, 100, 200 or 300 feet will prevent considerable current-loss at connections. Excess cable should be laid out in straight lines or large “U”s because coiling sets up an electrical field and reduces cutting or welding efficiency. To compensate for the voltage drop in a welding circuit the open circuit voltage must be increased. The voltage drops for various sizes of cables are shown in [Figure 4-10](#). This voltage drop does not include the effect of contact resistance which can be minimized by making sure all connections are completely insulated by wrapping in rubber tape, applying a layer of scotch cote, then a final wrap with electrical tape. The importance of waterproof connections cannot be over emphasized in underwater cutting or welding. A poorly insulated underwater connection allows a considerable current leak and very rapid deterioration of the copper cable. A poorly insulated connection between the whip (stinger) lead and the welding lead can be extremely dangerous to the diver. Bolt-on connectors are preferred as they are less likely to work loose. The life of any cable is increased by proper coiling when the cable is not in use and by minimizing its exposure to oil.

**4-2.6 Gas Manifolds.** Manifolds, sometimes referred to as coupler blocks, are used for the purpose of connecting two or more cylinders of the same kind of gas to discharge all of the cylinders through one regulator. The use of manifolds is desirable when it is necessary to furnish an uninterrupted supply of gas or when it is needed to supply gas at greater rates than can be supplied from a single cylinder.

Manifolds, are subjected to full cylinder pressure and they should, therefore, be strongly constructed. Oxygen manifolds should not be made of steel or iron pipe or copper tubing. They should be capable of withstanding a hydrostatic pressure test of 1-1/2 times the working pressure. For example, for use with oxygen cylinders rated at 2,000 psi, the manifold should be tested hydrostatically at 3,000 psi. Extreme care should be taken to see that no oil, grease or solvent is in an oxygen manifold when high-pressure oxygen is connected.

**4-2.7 Underwater Oxygen-Arc Cutting Torches.****WARNING**

It is unsafe to operate the torch without the flashback arrestor in place. To do so may cause injury and/or destroy the torch.

Underwater oxygen arc cutting torches are designed for gripping the cutting electrodes and for delivering power to the electrode and oxygen to the electrode bore. Safety is a primary consideration in their design and construction. All current-carrying parts of the torches must be fully insulated to afford full protection to the diver from electric shock and to protect the torch from rapid corrosion due to electrolysis. The torches also should be lightweight, simple in construction, easy to maintain and should incorporate an electrode clamping

S0300-BB-MAN-010

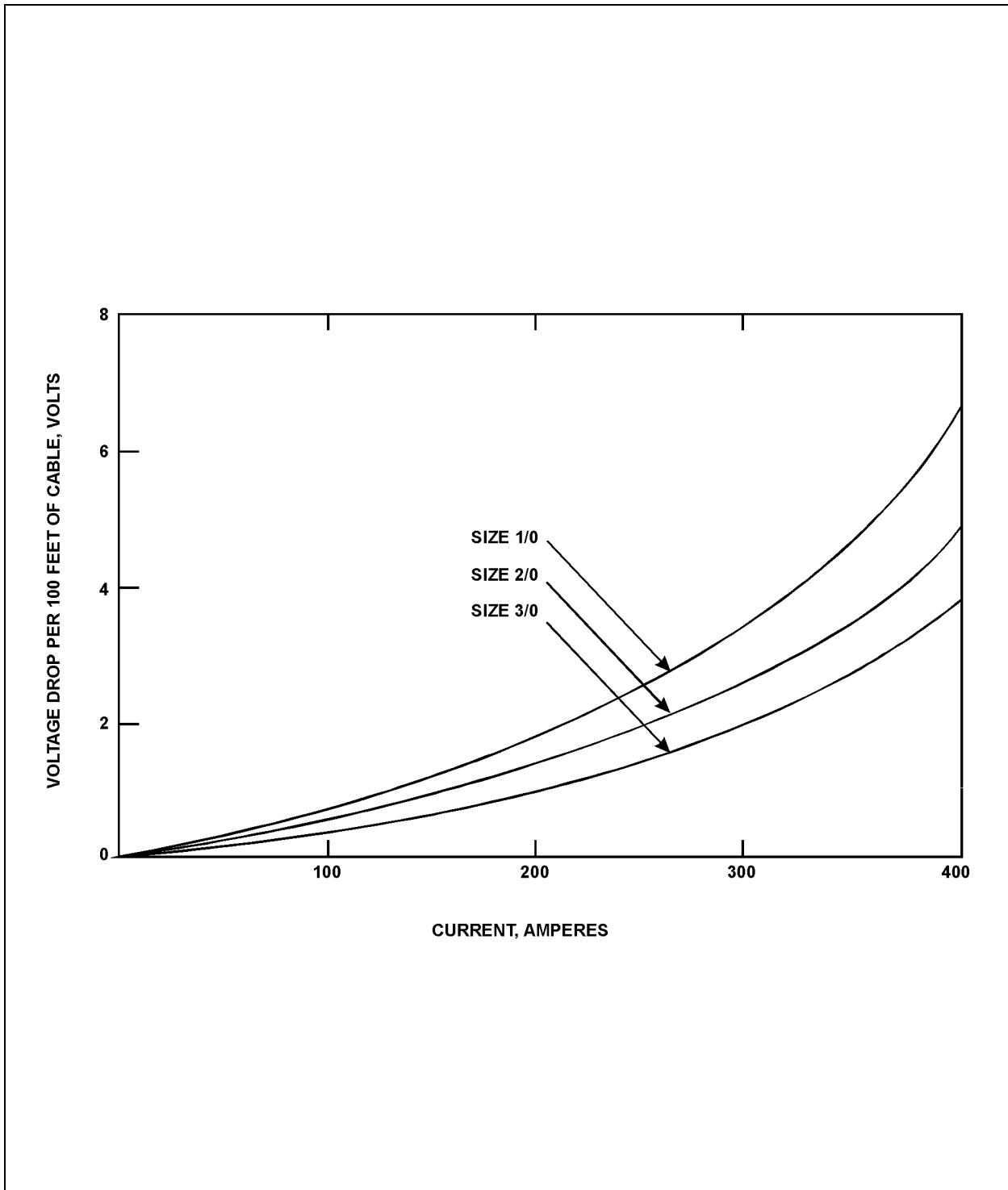

Figure 4-10. Voltage Drop in Welding Cables.

## S0300-BB-MAN-010

device which will make the changing electrodes underwater a relatively simple task. Only torches which have been designed specifically for underwater cutting shall be used. The torches must also have a sufficient capacity for the maximum current required by the electrodes with which the torch is to be used. The elements of an oxygen arc cutting torch are:

- a. Collet or grip which holds tubular cutting electrodes and provides for entry of oxygen into the cutting electrode bore.
- b. Oxygen valve for controlling oxygen flow rate.
- c. Electrical connector for attaching a power cable.
- d. Flash arrester to prevent hot metal particles from entering the torch. **Never, under any circumstances, operate a cutting torch without the flash arrester and monel screen.**
- e. Insulated coupling between the electrode and the oxygen valve to safeguard the operator from electric shock and to prevent damage of the valve due to electrolysis.
- f. Complete insulation for all current-carrying metal parts of the torch to safeguard the operator against electric shock and to protect the metal parts from deterioration by electrolysis.

The diver can check a particular torch or electrode holder for electrical integrity by calling for “switch on,” with the electrode not in contact with the work-piece. Bubbles due to electrolysis should arise only from the electrode tip. Bubbles occurring elsewhere indicate current leakage from the torch or electrode holder itself.

Figures 2-6a, b and c illustrates the elements of three torches specifically designed for underwater oxygen-arc cutting.

### 4-3 EQUIPMENT FOR UNDERWATER SHIELDED METAL-ARC WELDING

Basically, the same equipment used in underwater cutting is used for underwater welding with the exception of the torch; i.e., welding generator, welding leads and although the torch can be adapted for underwater welding, it is not practical to do so. Underwater electrode holders, which are light-weight, are recommended.

**4-3.1 Electrode Holders.** Underwater electrode holders differ from those used topside in their insulation and method of holding the electrode. Underwater holders are designed with a “twist-grip” action for gripping the electrode. The electrode can only be installed in one position (45 or 90° to the holder) as opposed to surface holders, which usually allow for both 45 and 90° positions of the electrodes. Underwater electrode holders should never be used for topside welding, as they are designed to be cooled by the surrounding water and would rapidly overheat. Some oxy-arc cutting torches can also be adapted for welding by changing the collet to fit the welding electrode. However, they are somewhat heavy for

## S0300-BB-MAN-010

welding and most experienced divers prefer the light-weight underwater “stinger” as it is most often called. Electrode holders are designed for welding and should only be used for that purpose and never as scrapers or hammers. A number of electrode holders specifically designed for underwater use are commercially available.

#### 4-4 WELDING ACCESSORIES

In addition to the basic equipment, the following accessories are necessary for underwater shielded metal arc welding.

- a. A supplementary welding shield attached to the diving helmet fitted with No. 4, 6, 8 or 10 or other appropriate welding lens.
- b. A suitable grounding clamp (C-clamp) to which the ground lead is bolted or preferably brazed, thus making it easy for the diver to connect the lead to the work.
- c. A weighted wire brush for cleaning the base metal and removing slag.
- d. A chipping hammer for removing slag, light rust and paint.
- e. A scraper for removing marine growth, rust and paint. In particularly bad cases, a hammer and chisel may be necessary.
- f. Tong test ammeter.
- g. Ultrasonic thickness and flaw detection equipment, when required.
- h. Magnetic Particle test kit
- i. Electrician’s DC volt meter.
- j. Pneumatic or hydraulic tools.

In planning any underwater work, every effort should be made to obtain and check all equipment and gear prior to reaching the job site. [Table 4-2](#) shows a typical load-out for wet welding and cutting. This list of equipment is suggested for a minimum load-out for an operation using two divers, both welding or cutting at the same time.

[Tables 4-3](#) and [4-4](#) are provided to aid in parts location of commonly used underwater cutting and welding equipment. [Table 4-3](#) is divided into two columns and lists:

- Manufacturer Vendor Codes as Listed in Defence Supply Cataloging Handbooks, H4-1 and H4-2.
- Names, Addresses and phone numbers of manufacturers.

## S0300-BB-MAN-010

Table 4-4 is divided into 4 columns and lists:

- Item and description alphabetically
- Military Specification Number.
- Federal Stock Code.
- Manufacturers part number (if applicable)

## S0300-BB-MAN-010

**Table 4-2. Equipment Load-out for Wet Cutting/Welding Operations**

Quantity	Unit	Description
<b>WELDING/CUTTING</b>		
2	Each	DC welding power sources: 400 amp capacity a. Checked for operation prior to load-out b. Fuel and oil source, if required, prior to load-out
3	Each	Knife switches: 400 amp/250 volt minimum
3	Each	Sets of welding leads: 2/0 size or larger. Each set to consist of: a. One ground cable 100 feet longer than the actual working depth with a "C" clamp attached (in an emergency, bolt a 2-inch x 6-inch x 1/2-inch flat bar on one end) b. One 100-foot cable for the welding machine to knife switch connection c. One cable for the knife switch to electrode connection; length determined by the depth of work and location of the knife switch
1	Each	Oxygen hose for underwater cutting (Length determined by working depth)
4	Each	Electrode holders with whip
2	Each	Cutting torches or one Kerie Cable Unit ( <a href="#">See Chapter 2, para. 2-4.2</a> )
A/R		Oxygen cylinders
2	Each	Two-stage, high-flow oxygen regulators
1	Each	Oxygen manifold
12	Each	Bolt-on connecting lugs for leads
6	Each	1-1/2 inch x 5/8 inch copper bolts and nuts

## S0300-BB-MAN-010

**Table 4-2. Equipment Load-out for Wet Cutting/Welding Operations**

<b>Quantity</b>	<b>Unit</b>	<b>Description</b>
<b>WELDING/CUTTING (CONT)</b>		
2	Each	Tubes of silicone lubricant for electrode holders
12	Each	Dark lenses: #4, #6, #8, and #10
4	Each	Lens holders for appropriate helmet
1	Each	Topside welding gear
1	Each	Topside oxy-acetylene burning gear
1	Each	Amperage tong meter
1	Each	Electrician's volt meter
12	Pair	Rubber gloves
24	Pair	Playtex-type gloves
48	Pair	Surgical gloves
6	Each	Soft leather rod bags and rubber bands
6	Each	Wire brushes - hand
6	Each	Chipping hammers - hand
1	Each	Pneumatic: Impact wrench, 1 inch Grinders - Large w/ 12 grinding disks Small w/ 12 grinding disks Chipping hammer Needle gun Chisels and needles Socket box Hose - 50 foot lengths OR
1	Each	Hydraulic: Power supply Impact wrench Grinders - Large w/ 12 grinding disks Small w/ 12 grinding disks Jack hammer Socket box Hose bundles - 50 foot lengths



## S0300-BB-MAN-010

**Table 4-2. Equipment Load-out for Wet Cutting/Welding Operations**

<b>Quantity</b>	<b>Unit</b>	<b>Description</b>
<b>WELDING/CUTTING (CONT)</b>		
2	Each	Framing squares
2	Each	Pipe wrap-arounds
1	Each	Ultrasonic thickness and flaw detection device
1	Each	Dye penetrant test kit
<b>TENDER'S TOOL BOX</b>		
2	Each	Hacksaws w/extra blades
Assorted		Open end and adjustable wrenches
Assorted	Each	Screwdrivers
2	Sets	Center punches
2	Sets	Files
		Hammers:
		Two 4 lb mauls
		Two 10 lb mauls
		Sledge hammer
4	Each	Rolls electrical tape (min)
4	Each	Rolls rubber tape (min)
4	Each	Rolls silver duct tape (min)
10	Feet	Heat-shrink tubing
<b>RIGGING EQUIPMENT</b>		
A/R		1/4 inch rope/wire
A/R		1/2 inch rope/wire
2	Each	Wire come-a-longs
2	Each	Chain come-a-longs
2	Each	Air tuggers
		Cable for tuggers
		Banding tool w/bands and clamps
		Slings and chockers
		Snatch blocks

## S0300-BB-MAN-010

**Table 4-2. Equipment Load-out for Wet Cutting/Welding Operations**

Quantity	Unit	Description
<b>MISCELLANEOUS</b>		
		Surface flood lights w/extension cords
		Underwater lights w/cable Spare light bulbs - surface and underwater
		Approved ground-fault detection (GFD) and/or interruption (GFI) devices
		Underwater flashlights Spare bulbs and batteries
		One of the two following systems:
		35mm still underwater camera w/strobe and close-up attachment; or
		TV system: Camera w/light and monitor System w/video and audio (hand held or helmet mounted) Video tape

S0300-BB-MAN-010

**Table 4-3. List of Manufacturer's**

<b>Manufacturer Code No.</b>	<b>Manufacturer</b>
N/A	Andersen Wet Weld P.O. Box 1529 New York, NY 10116-1529
09867	Arcair Company P.O. Box 406 Lancaster, OH 43130 (614) 653-5618
59491	BROCO Incorporated 2824 North Locust Avenue Rialto, CA 92376-1749 (714) 350-4701
N/A	Columbia Electric Mfg. Co. 4519 Hamilton Avenue N.E. Cleveland, Ohio 44114-3881 (216) 361-8060
94449	Craftsweld Equipment Corp. 26-26 Jackson Avenue Long Island City, N.Y. 11101 (718) 784-7346
57103	Duralac Inc. 84 Lister Avenue Newark, New Jersey 07105-4524
29156	3M Company 3M Center St. Paul Minnesota 55144-1000 (612) 733-1110
29192	Staveley Instruments 421 North Quay Kennwick, Washing 99336 (509) 735-7550
05670	Oxo Welding Equipment Company Cedar and Oak Streets New Lenox, Illinois 60451 (815) 485-8400

S0300-BB-MAN-010

**Table 4-3. List of Manufacturer's**

<b>Manufacturer Code No.</b>	<b>Manufacturer</b>
37775	Platex Ltd. 6363 Northam Drive Mississauga, Ontario Canada L4V
N/A	Proline Paint Company 2646 Main Street San Diego, California 92113
06023	Rego Company 4201 West Peterson Avenue Chicago, Illinois 60646-6020
94747	Seeler Enterprises 2046 Waverly Street Napa, California 94558-4637 (707) 252-8956
55681	TESCOM Corp. Smith Equipment Lockheed Avenue Waterton, SD 57201-5636 (605) 882-3200
63061	Victor Equipment Company Welding and Cutting Division Airport Road Denton, Texas 76201

## S0300-BB-MAN-010

**Table 4-4. Parts Information**

<b>Item</b>	<b>Military Specification Number</b>	<b>Federal Stock Group/Class</b>	<b>Manufacturer's Part Number</b>
Adhesive, non-water soluble		8040	N/A
Amperage tong meter		6610	N/A
Battery, 12 volt		6135	N/A
Bolt cutters		5110	N/A
Bolt-on connectors		5306	N/A
Chipping hammer	GG-H-35A 00-H-116D	5130	N/A
Cutting tip spacer sleeve (See Figure E-4)		5130	N/A
Cutting tip spacer Sleeve (AIRCO)		5130	N/A
DC Welding power supply (MILLER)	MS 336A	3433	902 571
DC Power Supply Sea-Pac 400-A (Aircair)		N/A	73-102-025
Electrician's volt meter		6610	N/A
Electrode holder	MIL-H-865D	3439	WBIN
Electrode holder Sea-Stinger II (Arcair)		N/A	14-050-128
Electrode holder (BROCO)		N/A	BR-20
Electrodes, oxy-arc cutting Sea-Jet (Arcair)			42-066-006
Steel-Tubular	MIL-E-17764	3439	MILE17764
Tuff-Cote			42-059-008

## S0300-BB-MAN-010

**Table 4-4. Parts Information**

<b>Item</b>	<b>Military Specification Number</b>	<b>Federal Stock Group/Class</b>	<b>Manufacturer's Part Number</b>
Electrodes, oxy-arc cutting Ultrathermic (BROCO)	- (continued)		
3/8-inch		N/A	3818-UW
1/4-inch		N/A	1418-UW
36-inch x 3/8-inch		N/A	3836-UW
Electrodes, SMA cutting and welding			
E 6013		3493	N/A
E 7014		3493	AWSAS.1- 78E7014
E 7018		3493	N/A
E 308		3493	N/A
E 309		3493	N/A
E 310		3493	N/A
E 312		3493	N/A
ENiCrFe-2		3493	N/A
ENiCrFe-3		3493	N/A
ENiCrMo-3		3493	N/A
Electrodes, SMA Wet Welding			
Andersen Easy Weld		N/A	#1
BROCO SofTouch		N/A	UW-CS-X
BROCO SofTouch		N/A	UW-SS-X
Epoxy 152 (2 part)	MIL-P-24441/3	8010	2439A/2439B
FS and Stinger cutting tips		5130	N/A
Fuel regulator, high capacity		6680	N/A
Gloves, rubber playtex surgical	22-G-381C	8415	N/A
Grounding Clamp	MS-39046A	5975	N/A
Hand mechanical igniter		5120	N/A

## S0300-BB-MAN-010

**Table 4-4. Parts Information**

<b>Item</b>	<b>Military Specification Number</b>	<b>Federal Stock Group/Class</b>	<b>Manufacturer's Part Number</b>
Kerie Cable Control Panel		N/A	LU-027
10-ft H.P. manifold		N/A	LU-033
Kerie Cable (SEELER)			
6 mm 50-ft roll		N/A	SP-A043
9 mm 50-ft roll		N/A	SP-A047
12 mm 100-ft roll		N/A	SP-A044
100-ft extension lead		N/A	LU-033
Wire cutter		N/A	LU-035
Insulation sleeve		N/A	LU-037
1/4" x 1/4" British Standard Pipe (BSP) double male adapter		N/A	LU-038
1/4" x 1/8" (BSP) double male adapter		N/A	LU-039
Knife switch, 400 amperes, 250 volts, unfusable		N/A	N/A
MAPP Gas, M70 cylinder		6830	N/A
Oxygen, cylinder-220 cu ft		6830	N/A
Oxygen hose		4720	N/A
Oxygen regulator, high-capacity		4820	N/A
Oxygen regulator, (BROCO) HIGH VOLUME OXYGEN		4820	HVR-4400
Scraper, paint		5110	N/A
Shrink-tubing		5970	N/A
Ultrasonic measuring device		5210	N/A

## S0300-BB-MAN-010

**Table 4-4. Parts Information**

---

<b>Item</b>	<b>Military Specification Number</b>	<b>Federal Stock Group/Class</b>	<b>Manufacturer's Part Number</b>
Underwater cutting torches			
Arcair		3433	14-050-126
BROCO		3433	BR-22
Crafsweld		3433	14-050-120
Weighted wire-brush		7920	
Welding cables	MIL-C-915/21		
size 1/0	MIL-C-915		
size 2/0	MIL-C-915		
size 3/0	MIL-C-915		

---



S0300-BB-MAN-010

S0300-BB-MAN-010

---

## APPENDIX A

---

### DOCUMENTATION MATRIX

#### A-1 PURPOSE.

The purpose of this matrix is to provide the user of this manual with a listing of additional reference documentation. This is given by reference manual and topic area.

#### A-2 REFERENCE DOCUMENTS.

The following manuals/publications are referenced on the matrix ([Table A-1](#)):

- SAFETY MANUAL - U.S. NAVY Ship Salvage Safety Manual (S0400-AA-SAF-010)
- SALVAGE MANUAL - U.S. Navy Salvage Manual
  - [Vol I Strandings](#) (S0300-A6-MAN-010/2K175)
  - [Vol II Harbor Clearance](#) (S0300-A6-MAN-020/2K175)
  - [Vol III Afloat](#) (S0300-A6-MAN-030/2K175)
  - [Vol IV Deep Ocean](#) (S0300-A6-MAN-040/2K175)
  - [Vol V POL Off Loading](#) (S0300-A6-MAN-050/2K175)
  - [Vol VI POL Spill Response](#) (S0300-A6-MAN-060/2K175)
- SALVORS HANDBOOK - U.S. Navy Salvor's Handbook (S0300-A7-HBK-010/2K175)
- UNDERWATER CUT & WELD - [U.S. Navy Underwater Cutting and Welding Manual](#) (S0300-BB-MAN-010/2K175)
- ENGINEERS HANDBOOK - [U.S Navy Salvage Engineer's Handbook](#) (S0300-A8-010/2K175) [Volumes I & II](#)
- TOWING MANUAL - U.S. Navy Towing Manual (SL740-AA-MAN-010)
- ESSM MANUAL - Emergency Ship Salvage Material Catalog (NAVSEA 0994-LP-017-3010)
- EXPLOSIVES MANUAL - Technical Manual for Use of Explosives in Underwater Salvage (NAVSEA SW061-AA-MMA-010)

S0300-BB-MAN-010

Table A-1. Salvage Documentation Matrix.

TOPIC AREA	Salvage Manual						Engineer's Handbook					
	Safety Manual	Volume 1	Volume 2	Volume 3	Volume 4	Volume 5	Volume 6	Salvor's Handbook	Underwater Cut & Weld	Towing Manual	ESSM Manual	Explosives Manual
Damage Control			•				•	•				
Stability	•				•		•	•	•			
Ship Strength	•				•		•	•	•			
Rigging	•	•	•		•	•	•	•		•		
Anchors	•	•				•	•	•			•	
Stranding		•			•		•	•	•			
Pulling Systems	•	•					•	•			•	
Safety	•	•	•	•	•	•	•	•		•		•
Machinery	•						•	•		•	•	
Explosives			•				•	•	•			•
HAZMAT	•				•	•	•	•			•	
POL	•				•	•	•	•				
Off Ship Fire Fighting	•			•	•		•				•	
Towing: Point to Point					•					•		
Rescue				•			•			•		
Patching		•	•	•			•	•				
Cofferdams							•	•				
Lifting Systems	•		•		•		•	•			•	
Pollution Control	•				•	•	•	•			•	
Pontoons			•		•		•	•			•	
Salvage Planning	•	•	•		•	•	•	•				•
Properties of Materials		•			•		•	•		•		•
Conversion Factors		•					•	•	•			
Computer Programming									•	•		
Deep Water Recovery				•			•				•	
Cutting	•		•					•				•
Welding	•							•				
Cargo Offload	•	•			•	•	•	•				

## S0300-BB-MAN-010

---

**APPENDIX B**

---

**METRIC CONVERSION FACTORS****METRIC TO ENGLISH**

kilograms x 2.2046	= pounds (lb)
kilograms ÷ 907.2	= tons (2000 lb)
millimeters x 0.03937	= inches (in)
or millimeters ÷ 25.4	= inches (in)
meters x 39.37	= inches (in)
meters x 3.281	= feet (ft)
meters x 1.094	= yards (yd)
sq millimeters x 0.00155	= sq inches (in <sup>2</sup> )
or sq millimeters ÷ 645.16	= sq inches (in <sup>2</sup> )

**ENGLISH TO METRIC**

pounds ÷ 2.2046	= kilograms (kg)
tons (2000 lb) x 907.2	= kilograms (kg)
inches ÷ 0.03937	= millimeters (mm)
or inches x 25.4	= millimeters (mm)
inches ÷ 39.37	= meters (m)
feet ÷ 3.281	= meters (m)
yards ÷ 1.094	= meters (m)
sq inches ÷ 0.00155	= sq millimeters (mm <sup>2</sup> )
or sq inches x 645.16	= sq millimeters (mm <sup>2</sup> )

## S0300-BB-MAN-010

**WEIGHTS**

1 pound (lb)	= 453.6 grams, or 0.4536 kilograms (kg)
1 pound per foot (lb/ft)	= 1.4882 kilograms per meter (kg/m)
1 net ton (2000 lb)	= 907.18 kilograms (kg)
1 gross ton (2240 lb)	= 1016 kilograms or 1,0160 metric tons
1 ounce per sq foot	= 305.15 grams, or 0.30515 kilograms per sq meter (kg/m <sup>2</sup> )
1 kilogram (kg)	= 2.2046 lb
1 kilogram per meter	= 0.67197 lb/foot = 2204.6 lb
1 metric ton (1000 kg)	= 1.10231 net tons = 0.98421 gross ton

**MEASURES**

1 inch (in.)	= 25.40 millimeters (mm)
1 sq inch (in. <sup>2</sup> )	= 645.16 square millimeters
1 sq foot (ft <sup>2</sup> )	= 0.092903 square meter
1 millimeter (mm)	= 0.03937 inch
1 sq millimeter (mm <sup>2</sup> )	= 0.00155 sq inch
1 meter (m)	= 3.2808 feet or 1.09361 yards
1 meter (m <sup>2</sup> )	= 10.7639 sq feet or 1.196 sq yards
1 gallon (U.S.)	= 3.785 litres
Gallons per minute (GPM)	= m <sup>3</sup> /second

## S0300-BB-MAN-010

**PRESSURE OR STRESS (FORCE/AREA)**

pascal (Pa)	= newton/meter <sup>2</sup> (N/m <sup>2</sup> )
pound-force/sq inch (psi) x 6894.757	= Pa
m Pa	= MN/m <sup>2</sup>
Thousand force per sq inch (ksi) x 6.894757	= M Pa

**TEMPERATURE CONVERSION**

Celsius (formerly known as centigrade)

$t_c$  = temperature (Celsius) in degrees

$t_f$  = temperature (fahrenheit) in degrees

$$t_c = \frac{t_f - 32}{1.8}$$

$$t_f = 1.8 t_c + 32$$

**METRIC PREFIXES**

Multiplication Factors		Prefix	Metric Symbol
1,000,000,000,000	= 10 <sup>12</sup>	tera	T
1,000,000,000	= 10 <sup>9</sup>	giga	G
1,000,000	= 10 <sup>6</sup>	mega	M
1,000	= 10 <sup>3</sup>	kilo	k
100	= 10 <sup>2</sup>	hecto	h
10	= 10 <sup>1</sup>	deca	da
0.1	= 10 <sup>-1</sup>	deci	d
0.01	= 10 <sup>-2</sup>	centi	c
0.001	= 10 <sup>-3</sup>	milli	m
0.000001	= 10 <sup>-6</sup>	micro	u
0.000000001	= 10 <sup>-9</sup>	nano	n

Metric prefixes should be used to indicate orders of magnitudes, thus eliminating insignificant digits and decimals. This provides a convenient substitute for writing powers of 10, as generally preferred in calculations.

For example:

12,300 m or 12.3 x 10<sup>3</sup> m becomes 12.3 km

and

400,000 Pa or 400 x 10<sup>3</sup> becomes 400 kPa

S0300-BB-MAN-010

S0300-BB-MAN-010

---

## APPENDIX C

---

### BIBLIOGRAPHY

ANSI/AWS D3.6, "Specification for Underwater Welding," American Welding Society, 1980.

AWS "Welding Terms and Definitions," American Welding Society, 1980.

AWS F4.1, "Recommended Safe Practices for the Preparation of Welding and Cutting of Containers and Piping that Have Held Hazardous Substances," American Welding Society, 1980.

Commercial Diving Manual, Richard Larn and Rex Whistler, David & Charles publishers. Second Printing 1986.

Electrician's Mate 3 & 2, NAVEDTRA 10546-E, 1981.

Hull Maintenance Technician 3 & 2, NAVEDTRA 10571-1, 1984 Revived 1987.

Naval Ships' Technical Manual (NSTM) [NAVSEA S9086-CH-STM-010]. Washington, D.C.: Naval Sea Systems Command. Chapter 074, Volume 1 — Welding and Allied Processes. September 1980, Change December 1984.

NAVSEA S0400-AA-SAF-010, U.S.Navy Salvage Safety Manual, 25 December 1988.

NAVSEA 0994-LP-018-5010, Operating and Maintenance Instructions, MK 12 Surface Supported Diving System, June 1980.

NAVSEA S6560-AG-OMP-010/SL17B/NS-DS118B, Operating and Maintenance Instructions, Superlite 17B/NS Helmet, 30 September 1987.

OPNAVINST 5100.19 Series, Navy Safety Precautions for Forces Afloat, 26 Jan 1983.

OPNAVINST 5100.23 Series, Navy Occupational Safety and Health (NAVOSH) Program, 31 August 1983.

NAVFAC P-990, Conventional Underwater Construction and Repair Techniques, not dated.

Santa Fe Diving Services, Inc., Diving Procedures and Safe Practices Manual, September 1980.

The Professional Diver's Handbook, Submex Limited 1982.

Underwater Electrical Safety Practices, Defense Documentation Center 1976.



S0300-BB-MAN-010

S0300-BB-MAN-010

---

**APPENDIX D**

---

**SAFETY IN UNDERWATER CUTTING AND WELDING****D-1 PURPOSE**

This appendix is intended to cover safety precautions to be followed while preparing for and conducting underwater cutting or welding operations. All personnel should read and comprehend the safety precautions listed in this section and the safety summary contained in the front section of this manual. Deviation from established standards are of course potentially dangerous; however, the most serious aspect of disregarding safety rules may not be the initial deviation, but the tendency to treat other rules just as casually. Remember, safety is a full-time job and the more safety-conscious each team member becomes, the safer each diving operation becomes.

For detailed information on chemical hazards encountered in salvage, refer to the *U.S. Navy Ship Salvage Safety Manual*, (S0400-AA-SAF-010), which covers toxic, explosive, corrosive and other special nature perils.

**D-2 GENERAL**

Underwater cutting and welding operations involve several hazards, including lethal electrical currents, oxygen and hydrogen rich gases which will explode in the presence of a spark and electrode tip temperatures in excess of 10,000°F. It is impossible to anticipate all possible situations that may arise in underwater cutting or welding operations. Consequently, it can not be assumed that safe operating conditions will exist simply by blindly following the guidelines set forth in this manual. Nonetheless, with a thorough knowledge of cutting and welding fundamentals combined with the use of common sense and sound judgment, the procedures described in this manual can be performed in maximum safety.

**D-3 EXPLOSIVE GASES****WARNING**

**Do NOT attempt to speed up the cutting by creating a fire or inferno deep inside the metal. Such a situation can lead to an explosion.**

S0300-BB-MAN-010

**WARNING**

**A diver is at risk to severe electrical shock when performing a cutting or welding operation while only partially immersed in water. Hence, the splash zone is the most hazardous location in which a diver can be placed.**

**WARNING**

**NEVER bring a cutting torch into a bell with the oxygen on or with the welding generator running.**

**D-3.1 General Information.** Gases produced by underwater cutting are rich in oxygen and hydrogen and will explode if trapped and ignited. Gases from underwater cutting will collect in closed compartments, open tubular structural members, open piping systems, shaped structural members and under such members as “H” beams. Before cutting, it is mandatory that provision be made to evacuate existing gases and eliminate the possibility of further gas entrapment. Refer to *Naval Ships Technical Manual NAVSEA S9086-CH-STM-030/CH-074 Volume 3* for detailed information on gas-free engineering.

If the presence of trapped explosive gas mixtures is uncertain, it may be necessary to drill holes in suitable locations to allow the gases to escape. This will flood the compartment with sea water. An alternative would be to purge the compartment with a mixture of gases which will not support combustion.

**D-3.2 Specific Information.** Underwater cutting and welding processes generate explosive gases.

- When cutting with power on or welding, hydrogen and oxygen are dissociated from the water and will travel separately as bubbles. These bubbles can collect in a trapped or confined space overhead. As the hydrogen and oxygen gases combine they will ignite, causing a popping sound.
- Oxygen cutting is about 60 percent efficient, resulting in approximately 40 percent pure oxygen being released into the environment. This gas can become entrapped above the work area, and when combined with a fuel such as hydrocarbons, can easily be ignited by a hydrogen bubble or a spark trapped in the bubble.

Any pop is a sign of explosive gases collecting above the underwater work area and is the point when cutting or welding must stop and the cause investigated.

Prior to the start of any underwater cutting or welding, as built drawings and physical configuration of the work area must be studied to determine all these areas and voids that could contain or

## S0300-BB-MAN-010

trap explosive gases. These areas and voids must be vented or made inert in accordance with Naval Ships Technical Manual NAVSEA 59086-CH-STM-030/CH-074 Vol 3 to prevent possible explosions.

Care should also be taken when cutting or welding on enclosures that are on or above river beds, especially in mud, because trapped methane gas in the proper concentrations can explode.

Explosive gases may be produced by any one or a combination of the following:

- Petroleum products such as gasoline, fuel oil or greases;
- Paint mixing mediums, such as linseed oil or thinners;
- Epoxies, adhesives and solvents;
- Ammunition or bulk explosives;
- Decaying vegetable or animal matter; and
- Unburned gases from cutting torches.

Every precaution must be taken to prevent an underwater explosion. To minimize the possibility of explosions from trapped gasses, the following procedures are recommended:

- a. Start cutting at the highest point and work downward.
- b. When cutting thick material, i.e., propeller shafting, cut from the outside and work around the circumference. By withdrawing the electrode every few seconds to allow water to enter the cut, exceedingly high temperatures can not build up inside the metal. A brushing or stroking action in the direction of the intended cut should be used.
- c. Gases may be vented to the surface with a vent tube (flexible hose) secured in place from the high point where gases would collect to a position above the waterline.
- d. When working under a sea chest, gas can be vented by briefly opening an internal valve or by the above method.

## S0300-BB-MAN-010

**D-4 ELECTRICITY UNDERWATER****WARNING**

**AC power shall not be used for underwater cutting or welding due to the extreme danger involved with AC current underwater. Electrical shock produced by AC current prevents voluntary relaxation of the muscles controlling the hand. Consequently, the diver may be unable to let go if his body or equipment accidentally enters the electrical circuit.**

Electricity and water are incompatible by nature and the use of electrically powered equipment underwater presents a potential shock danger to both the diver and the tender. When using electrically powered equipment such as cutting, welding or underwater lighting, the diver and tender must be protected from electric shock. All personnel engaged in underwater cutting and welding should be thoroughly trained in CPR and first-aid so they can render immediate assistance in the event of an accident.

The results of a study conducted for the Navy revealed that the principal underwater electrical hazard facing divers engaged in welding and cutting is non-lethal electric shock. The hazard exists when a diver wearing inadequate protective dress is in close proximity to a relatively high-powered source of electricity. **AC power was found to pose a considerably greater threat to the diver than DC, therefore AC power will NOT be used for underwater cutting or welding.**

Electrical current above shock levels that passes through human tissue is known to temporarily alter the physiological function of cells. The long-term effects, if any, are unknown. Much greater levels can cause thermal burns. Severe shocks could conceivably result in respiratory or cardiac arrest in divers. In addition, minor shocks may cause loss of control, panic or injury due to involuntary muscle contraction. Therefore, with the exception of a tingle at arc initiation, unpleasant electric shocks should not be tolerated in underwater operations, even though no physiological damage may be immediately apparent.

The safety rules listed in the following sections must be followed to provide maximum personal safety for the diver.

**D-5 GENERAL PRECAUTIONS FOR UNDERWATER CUTTING AND WELDING**

There are many conditions which contribute to making underwater work difficult. These include adverse currents, unstable footing, poor visibility and low temperatures. A constant source of danger comes from the falling or rolling of cut-away pieces. This is especially true in salvage wrecking. These, combined with the dangers involved in operating an electric arc capable of producing fatal shock, severe burns and explosive gas pockets, create a situation where the diver must be extremely alert.

## S0300-BB-MAN-010

The following precautions must be observed:

- a. Careful examination should be made before starting the cut to learn how the cut-away pieces will fall and whether there are any projections, wires or other objects which may foul lines or cause a piece to swing around in an unexpected manner.
- b. Be extremely careful when cutting tightly-bound wire rope e.g., wire wrapped in a ship's propeller. When severed, the wire can back-lash with spring-like force.
- c. Before cutting, ensure that umbilical and diving equipment will not be in the path of slag from the cutting operation.
- d. Avoid cutting overhead if possible, since the falling molten material will seriously damage the diving helmet, dress and umbilical.
- e. Never put down or carry an electrode holder while the power is on.
- f. Never change an electrode while the power is on.
- g. The diver must never allow any body part or equipment to come in contact with the grounded work when the safety switch is closed.
- h. Care should be taken with diver-carried large loose metallic items (i.e., wrenches and backpacks) to ensure no contact is made with a live electrode or the work.

## D-6 POWER SUPPLY

The power supply used for underwater cutting or welding shall consist of only approved electric welding machines and shall be tested for proper working order prior to use. **Use only DC welding power.** Electric welding equipment shall be installed by competent, experienced personnel in accordance with approved plans. This requirement is especially applicable to the installation of primary power lines and outlets intended to supply power to the electric welding machines. The equipment shall only be operated in accordance with the manufacturer's recommended operating procedures and the safety precautions outlined in this manual. Power supplies are covered in detail in [Chapter 4](#).

The following precautions are to be observed during set up and operation of arc cutting or welding equipment:

- a. Ensure that the welding machine frame and supporting structure are grounded before starting operations.
- b. Ensure that neither terminal of the welding machine is or becomes short-circuited to the machine frame before starting operations.
- c. Ensure that all electrical connections are securely made before starting operations.

## S0300-BB-MAN-010

- d. Stand on dry wood, rubber matting or similar insulating material and not on grounded metal.
- e. Wear dry rubber or rubberized-canvas gloves that are in good condition when handling energized holders, torches, cables or welding machines.
- f. Keep the welding machine commutators clean to prevent excessive flashing.
- g. Keep the welding machine clean and operable, free of oil and grease and (in electrical parts) free of metallic particles that can cause short circuits.

### **D-7 ELECTRODE HOLDERS AND CUTTING TORCHES**

The following are electrode holder and cutting torch precautions that should be observed:

- a. Use only torches and electrode holders that have been specifically designed for underwater applications. They must have the capacity to handle the maximum rated current required by the electrode being used.
- b. Inspect the apparatus and ensure that all current-carrying parts are fully insulated with nonconducting material. This material should safely insulate against the maximum voltage encountered to ground. Remember, new does not necessarily mean ready for use. Extra insulation may be required, which will provide further diver protection and extend the life of the electrode holder.
- c. Standard holders designed for surface use shall not be used except in exceptional situations. Refer to [Appendix E](#).
- d. Inspect the electrode holders for worn or damaged parts and insulating material and repair or replace any parts as necessary. Flashback arrestors and monel screens must always be in proper working order.
- e. Do not lower the welding or cutting torch before the ground clamp is securely attached near the work area.
- f. Before lowering or raising the electrode holder or ground clamp, ensure that the current is off and the knife switch is open.
- g. Never attempt to change or tighten an electrode with the current on.
- h. Never hold the holder so the electrode points toward the body. This can be likened to pointing a loaded pistol at oneself.
- i. Special care should be taken to avoid touching the metal parts of the diving equipment with the electrode or any uninsulated parts of the electrode holder.

## S0300-BB-MAN-010

- j. Never allow any metallic part of the diving dress to touch the work.

**D-8 POWER CABLES AND CONNECTORS**

The following are power cable and connector safety precautions that should be observed:

- a. All parts of the cables that are intended to be submerged shall be fully insulated and watertight. This can not be overstated.
- b. Inspect cables and cable connections for damaged insulation before starting operations. Defects in the cable must be repaired or the cable replaced before starting operations.
- c. All connections shall be made tight and thoroughly insulated by wrapping in rubber tape, applying a layer of scotch cote, then wrapping with electrical tape. This will prevent current loss at the connections. Cables which produce bubbles during operation should be replaced. The bubbles indicate that current is being lost through the porous insulation.
- d. Use only welding cables that are a minimum of 2/0 extra flexible. An exception is the electrode holder lead, which can be 1/0. The 1/0 lead is more flexible and will aid the diver in maneuvering the electrode holder. The cable must conform to the applicable requirements of Military Specification MIL-C-915. Cables must be capable of handling the maximum current requirements of the intended work.
- e. Do not use excessive lengths of cable with large sections stored on deck. When working in deep water, a strain relief should be provided across the connections to support cable weight.
- f. When connecting lengths of cable, use connectors which have a current carrying capacity that is equivalent to the cable being used.
- g. Ensure that the 1/0 stinger lead between the electrode holder and the welding lead is defect-free. The cable connection coupling the stinger lead to the 2/0 welding lead should be thoroughly insulated with a layer of scotch cote, wrapped in rubber tape, insulated with an additional layer of scotch cote, then finally wrapped with electrical tape or heat-shrink tubing. This will afford added protection for the diver.

**WARNING**

**The position of the ground in relation to the diver must be such that at no time does the diver or equipment become positioned between the ground and the electrode. The diver must avoid becoming part of the electrical circuit.**



## S0300-BB-MAN-010

- h. Secure the ground clamp as close to the work-site as possible, preferably in the forward line of vision. The diver must face the ground when welding or cutting. A good rule-of-thumb to remember is: NEVER TURN YOUR BACK TO THE GROUND WHEN THE POWER IS ON.
- i. Keep additional power cables such as underwater light cables and welding leads separated.

**CAUTION**

When AC power is required for underwater lighting or operation of hand tools, the AC equipment must be protected by ground-fault detection (GFD) and/or ground-fault interruption (GFI) devices.

- j. Cables should be strung overhead if they are to be run for long distances. If this is not practicable and they must be laid on deck, they must be protected and arranged to prevent interference with safe passage of personnel.
- k. When portable lighting is used, it should be clamped or fully secured in position and not hand held. The portable lighting power cords must be kept clear of the welding leads and work area. Additionally, a ground-fault detector/interrupter (GFD/I) must be incorporated in the circuit.
- l. Cables in storage should be kept dry and free of grease and oil, which cause premature breakdown of the insulation.

**D-9 SAFETY SWITCH**

A positive-acting, unfuzable current interrupt switch, rated at 400 amperes must be in the welding circuit. This switch protects the diver by breaking the electric circuit, thereby stopping the current supply to the electrode holder. A typical double-pole safety switch setup is shown in [Figure 4-8](#).

The safety switch, more often referred to as a knife switch, is the most important safety item included in the underwater cutting or welding equipment inventory. The diver is fully isolated from electric current when the knife switch is open. The tender (phone talker) should only be instructed to close the switch when the electrode is poised for cutting or welding.

**CAUTION**

It is extremely important to mount the switch correctly. The switch must be positively acting, rigidly mounted and located so that it cannot be accidentally knocked or vibrated closed. Should the switch fall, the circuit would be broken.

## S0300-BB-MAN-010

Both double-pole and single-pole safety switches are authorized, however a double-pole is the most often used because both the working and ground lead are opened or closed simultaneously (see Figure 4-8).

To ensure safety switch effectiveness, the following guidelines must be followed:

- a. When using a single-pole knife switch, it should be located in the welding-lead side of the electric circuit and should be able to handle the maximum welding current.
- b. The safety switch must be mounted vertically on a non-conducting (wooden, plastic, etc.) stand. The switch has an open circuit potential of approximately 80 volts across the poles. To prevent accidents, the safety switch should be fitted with a non-conducting slotted cover.
- c. When reverse polarity is required, the safety switch must be placed in the cutting or welding lead side of the circuit.
- d. Never operate a knife switch in a combustible atmosphere.
- e. The knife switch must be in proper working order. Additionally, the switch contact surfaces should be periodically checked for verdigris accumulation.
- f. The current shall be off (knife switch open) at all times, except when poised for or actually cutting or welding.

When a single-pole knife switch is used, special care must be taken to ensure that the safety switch is not shunted out between the switch and welding machine. Wet, bruised or worn cables can be shorted by rubbing against the welding machine frame, hatch combings or by lying on a steel deck. This creates a potential source of danger. Inspect the cable thoroughly and wrap any questionable spots in the insulation with rubber tape, followed by an additional layer of electrical tape or heat shrink. Periodic inspection should be made to ensure that the insulation is not damaged.

The safety switch shall be located in such a position that enables the phone talker or designated tender to operate or oversee the operation of the switch during the entire time the diver is in the water. The switch shall not be closed unless specifically directed by the diver to do so. The phone talker shall confirm each change to the diver via the intercommunications system.

## D-10 FIRE AND EXPLOSION PREVENTION

### WARNING

**Hydrocarbons ignite almost spontaneously in the presence of oxygen. Never allow oxygen-carrying components to come in contact with oil or grease.**

## S0300-BB-MAN-010

**D-10.1 Major Causes.** The major causes of fire and explosion are listed as follows:

- combustibles reached by the arc,
- flying sparks,
- hot slag,
- misuse of compressed gases and cylinders and
- short circuits.

It is necessary for the diving supervisor be aware of topside work being conducted in the vicinity of the diving station. Do not allow welding or cutting in an area where there are combustibles. Sparks and slag can fly up to 35 feet.

Keep equipment clean and operable, free of oil and grease and free of metallic particles (in electrical parts) that can cause short circuits.

## **D-11 COMPRESSED GAS SUPPLIES**

Oxygen is used in the oxygen arc cutting process. The gas is stored in high pressure cylinders and delivered at a reduced rate via the regulator to the cutting torch. Of all the high pressure gases handled during diving operations, oxygen is the most hazardous. This is true because it lowers the ignition temperature of flammables and greatly accelerates combustion. Hydrocarbons ignite almost spontaneously in the presence of oxygen and oxygen fires create intense heat. The following paragraphs describe precautions to be followed when handling compressed gases.

**D-11.1 Use, Handling and Storage of Compressed Gases.** The necessity for following the precautions in the lists below cannot be too strongly emphasized.

### **D-11.1.1 The Never List**

- a. Never use a cylinder or its contents for other than its intended use and **NEVER** use a cylinder (not even an empty one) as a roller or support.
- b. Never use valve protection caps for lifting cylinders.
- c. Never use a magnet for lifting.
- d. Never use slings for lifting. Use a cradle or pallet with proper cylinder spacers.
- e. Never use a hammer or wrench to open cylinder valves.
- f. Never drop or allow any cylinder to fall, especially one that contains oxygen.

## S0300-BB-MAN-010

- g. Never tamper with safety plugs (safety relief valves).
- h. Never connect a regulator to a cylinder containing a gas other than that for which the regulator was designed.
- i. Never, under any circumstances, tap an electrode against a cylinder or any other pressure vessel to strike an arc. It creates a brittle area that can cause a violent rupture or can lead to such a rupture under rough handling.

### **D-11.1.2 The Always List**

- a. Always open cylinder valves slowly to allow a gradual pressure build-up and to prevent diesel effect in the line or regulator.
- b. Always keep cylinders away from hot work areas so that sparks, slag or flames will not reach them.
- c. Always store cylinders, both full and empty, in a manner that prevents their being knocked over.
- d. Always keep valve protection caps in place and hand tight, except when in use or connected for use.
- e. Always clear the cylinder valve connections of any dirt particles by briefly opening and closing the valves before connecting regulators. Do not stand in direct line of a cylinder valve when opening it.
- f. Always purge manifolds in a similar manner before connecting regulators.
- g. To lessen the chance of rupturing the diaphragm, always ensure that the regulator adjusting screw is backed out all the way before opening bottle valve.
- h. Always remove faulty regulators from service. The following symptoms indicate a faulty regulator:
  - 1) External leaking.
  - 2) Excessive creep in delivery pressure with the downstream valve closed.
  - 3) Faulty gauge (if the gauge pointer does not move off the stop pin when pressurized or does not return to the stop pin after the pressure is bled off).

Additionally, the following general rules must be observed:

- a. Check identification tags for proper gas.

### S0300-BB-MAN-010

- b. Avoid storing cylinders in heavy traffic areas, such as near access or gangways of vessels.
- c. Do not store cylinders in unventilated enclosures.
- d. Secure all cylinders that are not actually in use in designated storage racks.
- e. Protect hoses from damage due to sharp edges, sparks, slag and open flame.
- f. Examine hoses regularly for leaks, wear and loose connections. Use non-ionic soap suds or a proper liquid leak detector.
- g. Ensure that all compressed gas cylinders are within the hydrostatic test date.
- h. To prevent a set in the diaphragm, always back the regulator adjusting screw out all the way before placing it into storage.
- i. The diving tender must pay close attention to the gas pressures and change out cylinders when cylinder pressure drops to within 100 psi of the overbottom pressure. This will prevent damage to the torch and possible diver injury.

#### **D-11.1.3 General Oxygen Precautions.** The following oxygen precautions must be observed:

- a. Avoid electrical circuit contact with cylinders, including electrical wires or welding circuits. They can produce short circuit arcs that can lead to a very serious accident.
- b. Oxygen cylinders, valves, regulators, hoses, fittings and other apparatus shall not be handled with oily hands, gloves or greasy materials.
- c. Never allow a jet of oxygen to strike an oily surface, greasy clothes or enter a fuel tank which contains or has contained a flammable substance.
- d. Never use oxygen as a substitute for compressed air or a source of pressure.
- e. Under no circumstances are air hoses to be used in oxygen systems of any kind.
- f. Do not store oxygen cylinders gauges or fittings where they may become fouled with oil or grease.
- g. Store oxygen cylinders separately from fuel gases.

**D-11.1.4 General MAPP Gas Precautions.** MAPP gas is a colorless, odorless combustible fuel gas. Like all fuel gases which are odorless by nature, a chemical has been added to aid in detecting leaks by smell. Like any other combustible gas, MAPP gas forms explosive mixtures with air or oxygen. The following precautions must be observed:

## S0300-BB-MAN-010

- a. During set-up procedures, point the MAPP gas valve outlet away from the oxygen cylinder before cracking to clear the valve connections.
- b. When MAPP gas lines are being purged, do not permit open lights or other sources of ignition in the vicinity of uncapped openings.
- c. Do not use copper connections or fittings with MAPP gas. There is a slight possibility that MAPP gas may react with copper to produce explosive acetylides when the gas is under high pressure.
- d. Never use a match or flame as a leak detector. Use non-ionic soap suds or a proper liquid leak detector.
- e. A lighted cutting torch must be handled with care to prevent the flame from coming in contact with the diver's dress or umbilical. A lighted torch should not be left unattended or in such a position that it is free to swing and possibly foul lines.
- f. Lowering a lighted MAPP gas torch to a diver should be done only in shallower depths and in locations where it is absolutely certain that the flame can be kept clear of all hoses, lines and the diver's umbilical and dress. A lighted torch should never be lowered until the diver is ready and watching for it.

**D-11.2 Additional Safety Precautions.** The following additional precautions must be observed:

**CAUTION**

Sparkless tools are made of an alloy containing beryllium, which is extremely poisonous. DO NOT buff, steel wire brush or grind tools containing beryllium as this action will release particles, dust or vapors which may be ingested. Obtain medical attention as soon as possible should cuts or ingestion occur. Consider all reddish, copper-colored tools as containing beryllium until or unless it is known otherwise. Such tools are not usually marked when they contain beryllium. Although, they may be marked with a Low-Mu mark.

- a. Use only authorized equipment which is in proper working order. All equipment shall be operated and cared for in accordance with manufacturers operating and maintenance instructions.
- b. A diving tender shall be assigned to the care and control of the gas, with unhindered, quick access to the valves in case of an emergency.
- c. Frequently inspect for evidence of leaks in the hoses, couplings, valve stems or other parts of the system while equipment is in use, especially in confined spaces. Failure to

## S0300-BB-MAN-010

do this can result in the accumulation of an explosive mixture. This is a serious explosive hazard.

- d. Metal tools (even the “sparkless” type) shall be used with caution to avoid making a spark. Such a spark could cause an explosion if the proper mixture is present.

### **D-12 PERSONAL SAFETY IN DIVING**

**D-12.1 Diving Dress.** It is extremely important that the diving attire afford maximum protection against electric shock and eye injury from electric arcs. The U.S. Navy Mk 12 Surface Supported Diving System (SSDS) affords the diver maximum protection, provided the dress is in good condition. In addition, the following guidelines are offered:

- a. A standard neoprene wet suit may be used, provided it is in good condition with the suit’s cellular structure intact. The suit must be free of tears, holes or other defects which may impair the electrical-insulation properties.
- b. Defect-free rubber or neoprene gloves over a pair of Playtex-type or surgical gloves are recommended for maximum protection. The glove gauntlets should fully cover the wrist. When performing underwater cutting, the gauntlets should be secured at the wrist to prevent slag from getting into the glove. Glove integrity is extremely important.
- c. The proper welding shield must be fitted to the helmet when electric arc cutting or welding is to be performed. The shield should be fitted with the appropriate welding lenses for the water conditions at the work site.

For maximum protection against shock, diver-support equipment for electric arc underwater cutting or welding should completely insulate the body, including the head, hands and feet.

### **D-13 CONCLUSION**

This Appendix has presented both general and specific safety precautions dealing with underwater cutting and welding and the necessary support equipment. The rules covered herein represent the minimum acceptable safety standards to be observed while engaged in underwater cutting or welding operations. The aim is to reduce the risk associated with the use of high-pressure gases, electricity and underwater explosive gases. Periodic review of this appendix is encouraged.

S0300-BB-MAN-010

---

## APPENDIX E

---

### EXCEPTIONAL SITUATIONS

#### E-1 PURPOSE

This appendix is intended to cover cutting and welding procedures and equipment which may be used during exceptional situations. Normally, the procedures covered in [Chapters 2 and 3](#) will be followed, using authorized equipment tabulated in [Table 4-4](#). However, when authorized equipment is not available and a situation requiring immediate action is at hand, alternate equipment and/or procedures will likely be necessary. Such a predicament is known as an “emergency” or “special circumstance” situation. Some examples of the terms “emergency” and “special circumstance” are defined as follows:

- a. A ship in irons (wire in her screw) drifting toward a lee shoal, would be deemed an emergency.
- b. A salvage operation, away from normal logistic support, would be deemed a special circumstance.
- c. A stricken submarine, with life aboard, would be deemed an emergency.

**E-1.1 Discussion.** Alternate equipment is defined as commercially available equipment which has not undergone specific Navy design, safety review or test and evaluation and therefore, is not identified in [Table 4-4](#) or included in the *Authorized for Navy Use* (ANU) list, NAVSEAINST 10560.2 Series. The equipment has, however, been commercially proven safe and operationally adequate.

**E-1.2 Authorization.** Commanding officers are authorized to procure and use such equipment when such action is deemed necessary for the accomplishment of a specific job. This authorization is to be effective only for the duration of the particular emergency or special circumstance. In this situation the commanding officer is accountable to ensure all operating and safety procedures are strictly followed.

#### E-2 UNDERWATER CUTTING EQUIPMENT

**E-2.1 Arcwater Cutting.** Water arc cutting is essentially a melting process. Water is used to blow the molten metal out of the kerf. Since the cutting is dependent solely on the melting action of the arc, all the power available, up to 500 amps may be used. The process is limited to one manufacturer and may prove valuable when gouging out welds or cutting thin metal.



## S0300-BB-MAN-010

**E-2.2 Principles of Operation.** The process consists of striking an arc underwater between a carbon-graphite, copper-coated and waterproofed electrode and the workpiece. The metal is instantly transformed into a molten state and is blown away by a high-pressure jet of water which exits the torch through an orifice located directly below the electrode opening in the torch.

**E-2.3 Applications.** This process can be used for the following applications:

- a. It can be used on almost all metals found in ships and underwater structures.
- b. To remove defective fillet welds for rewelding.
- c. To cut metal in a manner similar to the underwater oxygen-arc process.

**NOTE**

Cutting material in excess of one inch with this process is not practical.

- d. Cracked butt or seam welds can be grooved for weld repair.

**E-2.4 Necessary Equipment.** The following equipment is required when using the arcwater underwater cutting process.

**E-2.4.1 Power.** A DC welding generator capable of providing a constant open-circuit voltage of 60 volts and 350-500 amperes. This process calls for reverse polarity. That is: electrode positive (+).

**E-2.4.2 Water.** The process requires a constant supply of sea water or fresh water supplied at a flow-rate of 3.5 gallons per minute at 90 psi over bottom pressure. A ship's firemain will normally provide sufficient pressure for this process.

**E-2.4.3 Arcwater torch.** The arcwater torch ([Figure E-1](#)) is electrically insulated and completely waterproofed except in the area where the electrode is inserted. It is small and well balanced, designed to minimize diver fatigue.

**E-2.4.4 Electrodes.** The arcwater torch is designed to use especially formulated, copper-coated waterproofed electrodes. The electrodes dimensions are 5/16" x 9" and are completely waterproofed except the end which is inserted into the torch. The arc end has a special waterproofing which is removed by lightly tapping the electrode against the work.

S0300-BB-MAN-010



Figure E-1. Arcwater Torch Assembly.

## S0300-BB-MAN-010

**WARNING**

The position of the ground in relation to the diver must be such that at no time does the diver or his equipment get between the ground and the electrode. The diver must avoid becoming part of the electrical circuit.

**NOTE**

Thick, gauntlet-type rubber gloves in good condition, worn over a pair of Playtex-type gloves afford the best protection against electrical shock. They should be secured at the wrist to prevent slag from getting inside the gloves. In cold water, wet suit gloves in good condition, worn over surgical gloves are equally effective.

**E-2.5 Arcwater Electrode Cutting Technique.** As always, before conducting any type of electric arc cutting underwater, a ground cable must be attached to the work piece. The diver can either leave the surface with the cutting torch, ground cable and cutting electrodes or they can be lowered after arrival at the work site. The first task is to clean a spot for the ground clamp. The spot should be in a position in front of the diver and should be scraped or wire brushed shiny clean. For diver safety, only C-type clamps should be used as grounding clamps for underwater cutting or welding operations. The clamp must be firmly secured to the work piece and the cable should have sufficient slack to prevent it from being pulled loose. The diver may elect to lightly tack weld the clamp in place when there is a possibility of it working loose. From time to time as the cut progresses, the diver may have to reposition the ground clamp to avoid becoming part of the electrical circuit.

**E-2.5.1 Underwater Preparations.** Insert the electrode into the collet opening until it bottoms out. Tighten the collet nut. To start cut, hold electrode perpendicular to the surface to be cut. Place tip of electrode against the work and call for water on and then SWITCH ON. If necessary, withdraw electrode slightly and tap it against the work to start the arc.

**E-2.5.1.1 Cutting.** For cutting, the torch should be held at a 75° angle with the water jet under the electrode. Care must be taken to prevent molten metal blow-back. Once a hole is pierced, proceed along the intended line of cut using a sawing motion. Holes can be pierced in the same manner and enlarged using a sawing motion.

**E-2.5.1.2 Gouging.** The depth of the groove will vary with torch angle, travel speed, amperage and pressure exerted on the electrode. For gouging and weld removal, the torch

## S0300-BB-MAN-010

should be held at a 40° angle to the work with the water jet under the electrode. The torch should be moved forward at a speed sufficient to maintain the arc and the desired groove depth. The diver should not cut deeper than 1/4" in a single pass. This will prevent molten metal from being blown back at the diver.

**WARNING**

When the arcwater electrode has been consumed to within 1.5 inches of the torch, stop the cut and signal for SWITCH and water OFF before changing the electrode. Maintain the torch in the cutting position until the tender signals SWITCH OFF. Then tap the electrode twice to make sure the current is off. This safety precaution is mandatory, regardless of the type of electrode used.

**E-2.6 Material Consumption.** [Table E-1](#) is provided for planning purposes. It lists an approximate range of cut through various plate thicknesses up to 3/4-inch plate. Allowances should be made for diver proficiency and underwater conditions such as visibility, metal cleanliness and current.

**E-2.7 Post-dive Maintenance.** After each use, rinse the torch in fresh water and dry it. Disassemble and inspect for corrosion damage due to electrolysis. Replace any damaged parts as applicable. All equipment should be thoroughly dry before storing. Secure hose ends with caps or tape to keep out debris. Store all equipment, including electrodes, in an oil-free environment.

**E-3 CUTTING UNDERWATER WITH THERMIC LANCE (BURN BARS).****WARNING**

This process produces large quantities of hydrogen gas. When combined with oxygen, these concentrations are highly explosive and will produce random explosions of some magnitude. Several divers engaged in salvage work have been killed using this process.

## S0300-BB-MAN-010

**WARNING**

Thermic Lances or Burn Bars are NOT to be used by divers while underwater or by topside personnel performing a cut below the waterline while a diver is in the water. However, during situations where it would be impossible to place a diver in position for cutting and where the cutting can be accomplished from the surface, the Thermic Lance may be used with EXTREME CAUTION!

**Table E-1. Arcwater Operating Data Cutting Carbon Steel<sup>1</sup>**

<b>Metal Thickness</b>	<b>Inch/min cut</b>	<b>Water Over Bottom pressure</b>	<b>Amperage Range for Cutting</b>
0.1875	22.0	90-110 psi	475-525
0.2050	16.0	90-110 psi	475-525
0.375	12.4	90-110 psi	475-525
0.500	8.4	90-110 psi	475-525
0.625	4.2	90-110 psi	475-525
0.750	1.4	90-110 psi	475-525

1. Stainless steel operating data is similar to carbon steel. Non-ferrous materials such as bronze and brass with copper content above 80% can be cut with above operating conditions.

## S0300-BB-MAN-010

**WARNING**

Always wear protective clothing when using the Thermic lance: full protective suit, leather gloves, tinted face shield and a hard hat.

**CAUTION**

Keep all Thermic lance materials away from oil and/or grease.

Frequently, during a salvage operation, conditions prevent safely placing a diver in position for cutting. Such a situation might be a wrecked barge wrapped around a bridge pier in strong current or a situation where cutting from the surface through torn and twisted metal will be required. In such cases a Thermic Lance or burn-bar can be used to perform the cut. Still another application underwater is to cut holes in reinforced concrete.

**E-3.1 Material Description.** The Thermic Lance is a steel tube, 10-feet long by 3/8-inch in diameter, filled with ferrous or non-ferrous wires or rods being held in place by the crimped ends. At the standing end of the tube there is a holder and a connection for an oxygen hose. Due to the tremendous heat produced at the tip when oxygen is forced through the tube, the Thermic Lance will burn through almost anything. Any readily oxidable material such as iron, steel, non-ferrous metals, rock, masonry and concrete can be burned through or melted. It is difficult to handle underwater because of its length and it consumes a enormous amount of oxygen. The burning time for one lance is about 6-minutes. A number of lances can be coupled together for longer burning, but the extra length makes it extremely awkward to handle. The lance must be ignited by an outside source e.g., a cutting torch. The only way to extinguish the lance is to turn the oxygen off. To keep the flame from burning up the oxygen hose, it is necessary to secure the oxygen when the lance is consumed down to one foot in length.

The Thermic Lance has a major drawback or disadvantage. It produces large quantities of hydrogen in the cutting/reaction process. When the hydrogen gas combines with the oxygen in large pockets, there will be heavy concentrations of explosive gas.

These concentrations are well within the flammability and detonation limits of the gasses, producing random explosions of some magnitude. Obviously, there is a serious hazard connected with the use of Thermic Lances underwater because of the random explosions of large gas bubbles formed during operation. The explosions have killed a number of divers engaged in salvage work.

## S0300-BB-MAN-010

**E-3.2 Required Equipment.** The following is a list of required equipment:

- a. Thermic lance.
- b. Thermic lance holder/ball valve assembly.
- c. Oxygen (One burn bar requires 60 cubic feet of oxygen).
- d. 25 to 50 feet of 3/8 or 1/2-inch oxygen hose (Hose with smaller than 3/8-inch diameter will not deliver sufficient oxygen).
- e. A two-stage, high volume regulator.
- f. Ignition equipment. (oxy-acetylene torch).

**E-3.3 Set Up Procedure.** The following is the recommended set up procedure:

- a. Connect regulator to oxygen source.
- b. Connect oxygen hose (3/8 or 1/2-inch) to regulator.
- c. Connect lance holder, [Figure E-2](#), to hose.
- d. Adjust regulator to 80-120 psi.
- e. Insert lance into holder.
- f. Check for leaks—Open and close ball valve on holder.
- g. Purge the lance and close valve.
- h. Ignite oxy-acetylene torch and adjust to hottest flame.
- i. Light end of Thermic lance with oxy-acetylene torch. Adjust oxygen.
- j. The lance will begin to sparkle and will increase as more oxygen is applied.
- k. The Thermic lance is now ready to use. Place it against the work-piece and begin cutting. [Figures E-2](#) and [E-3](#) show a thermic lance equipment set up.

**NOTE**

The thermic lance will operate on oxygen pressures from 80-120 psi. If the pipe burns faster than the filler rods, use more pressure. If the filler rods burn much faster than the pipe, use less pressure.

S0300-BB-MAN-010

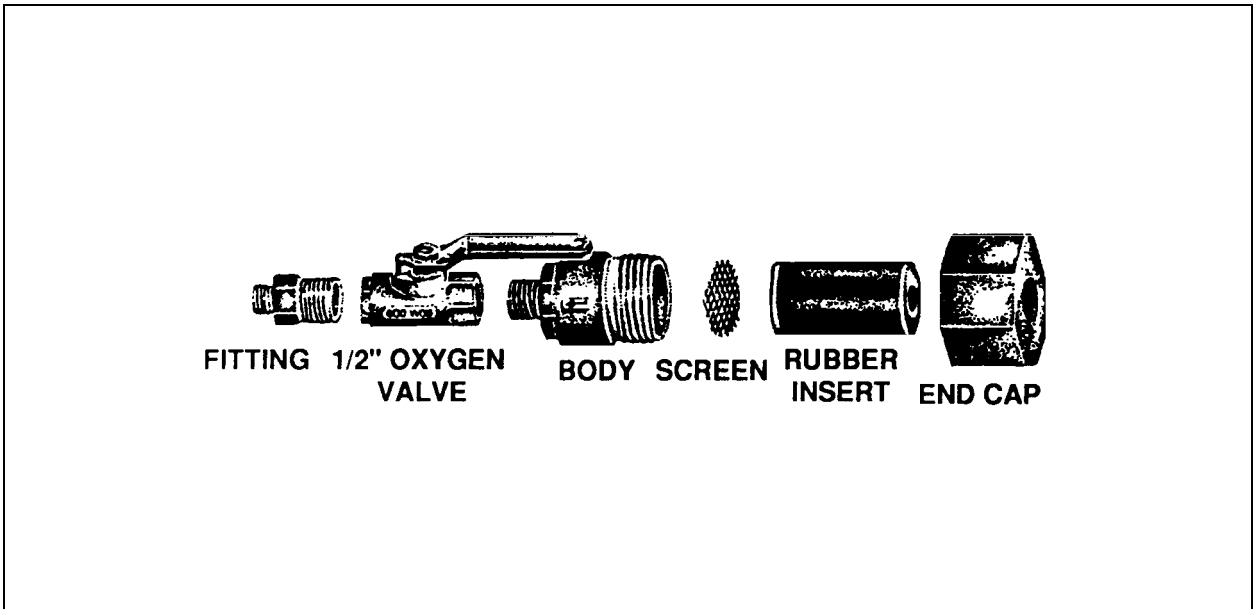
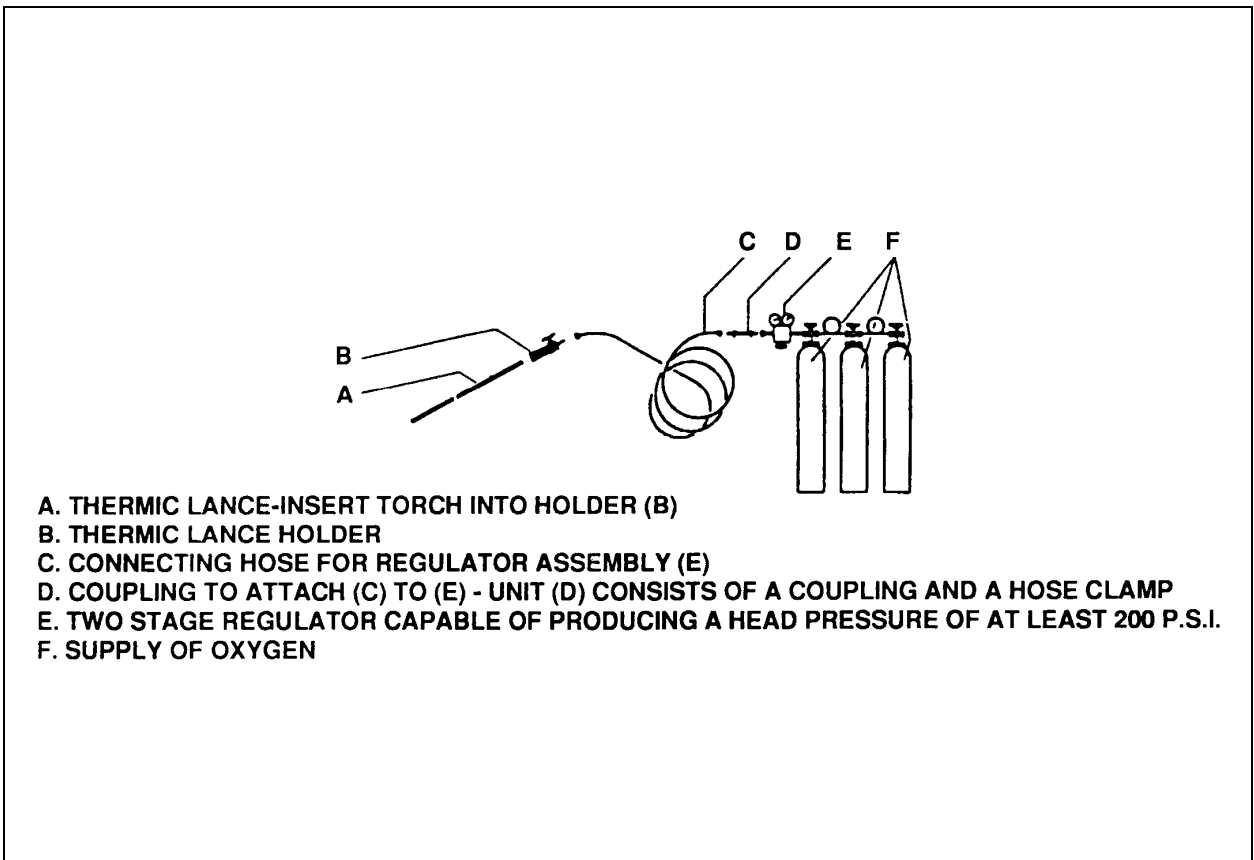

Figure E-2. Thermic Lance Holder Assembly.



- A. THERMIC LANCE-INSERT TORCH INTO HOLDER (B)
- B. THERMIC LANCE HOLDER
- C. CONNECTING HOSE FOR REGULATOR ASSEMBLY (E)
- D. COUPLING TO ATTACH (C) TO (E) - UNIT (D) CONSISTS OF A COUPLING AND A HOSE CLAMP
- E. TWO STAGE REGULATOR CAPABLE OF PRODUCING A HEAD PRESSURE OF AT LEAST 200 P.S.I.
- F. SUPPLY OF OXYGEN

Figure E-3. Standard Thermic Lance Equipment Set Up.



## S0300-BB-MAN-010

**E-3.4 Material Consumption.**<sup>1</sup> One Thermic lance will penetrate 24-inches of reinforced concrete producing a hole 2-1/2 inches in diameter using 60 cubic feet of oxygen in 5 minutes.

**E-4 MAPP GAS CUTTING****WARNING**

Acetylene is very unstable at pressures above 15 psi and is NOT used for underwater cutting.

MAPP Gas cutting is the only oxygen-fuel underwater cutting process approved for use by the Navy. It is used only when oxy-arc cutting equipment is not available or when there is an absence of sufficient electric power to conduct oxy-arc cutting.

MAPP gas is a mixture of stabilized methylacetylene propidene.

MAPP gas cutting is performed with a gas torch rather than with a cutting electrode. The technique for underwater cutting is exactly the same as oxygen-acetylene cutting topside. However, a great deal more skill is required using the MAPP gas process as opposed to Oxy-Arc underwater cutting.

Like Kerie Cable, this process is useful in ship salvage operations especially in areas where stringing long electrical power leads is difficult. Also, the necessary equipment can be carried in a small boat. The standard acetylene oxygen cutting torch is approved for Navy use. A spacer sleeve is attached over the cutting tip which aides the diver in maintaining the proper stand-off from the metal to be cut.

**E-4.1 Principles of Operation.** The principle of cutting metal underwater with a gas torch is virtually the same as that employed topside, except that the acetylene has been replaced with MAPP gas. The torch mixes the MAPP gas and oxygen which burn and generate sufficient heat to melt the metal to be cut. A small area on the metal is heated to a molten puddle and then oxygen is directed at that point. The oxygen instantly converts the molten puddle into a gaseous and chemical state, while simultaneously blowing it away. The flame is angled slightly in order to preheat the metal ahead of the cut, thus allowing the cut to continue.

---

1. These figures are manufacturer's estimates

## S0300-BB-MAN-010

**E-4.2 Equipment and Material.** The equipment generally required for underwater MAPP gas cutting is listed in Table E-2. Only approved equipment shall be used. Prior to use, it shall be examined, tested and determined to operate properly. The entire assembly, from cylinders to torch is essentially one complete functioning unit. The condition of internal cleanliness and repair of regulators, gauges, manifolds torch and hoses will govern the overall operating efficiency. A fleck of dirt in a regulator topside can cause complete failure at depth.

**Table E-2. Equipment and Material Requirements for Underwater MAPP Gas Cutting Equipment**

---

MAPP gas and oxygen supply
Torch equipped with torch tip spacer sleeve
Torch tip cleaner
Oxygen and fuel hose with proper fittings
High-capacity, 2-stage oxygen regulator
High-capacity, 2-stage fuel regulator
Hand mechanical torch igniter
Necessary tools
Appropriate diving equipment

---

## S0300-BB-MAN-010

**E-4.3 Protective Clothing.** MAPP gas cutting may be conducted underwater without special protective clothing or devices.

**E-4.4 Cylinders and Regulators.** Eight to ten 220 cubic feet cylinders of oxygen is required for each M-70 cylinder of MAPP gas. All cylinders must be secured in an upright position. When operating in extremely cold weather, it may become necessary to warm the MAPP gas bottles to maintain vapor pressure and proper gas flow. This may be accomplished in a heated deck room or with warm water. Never heat compressed gas cylinders with an open flame. Cylinders may also be warmed by placing them in front of radiators of running machinery such as welding machines or air compressors.

High-capacity, two-stage regulators should be used on both the oxygen and MAPP gas cylinders, although a standard fuel regulator equipped with a high pressure spring may be used on the MAPP gas cylinder. Hydrogen regulators, which are commercially available, may also be used with MAPP gas cylinders, however an adapter is necessary. A 15 psi overbottom pressure is required.

To avoid blockage of the torch due to dirt or foreign matter entering the jets, it is important to flush the various components with high-pressure gas before final connection. The following is the recommended set-up procedure:

- a. Clear the cylinder valve connections of any dirt particles by briefly opening and closing the valves of both oxygen and MAPP gas cylinders.
- b. Purge manifolds in a like manner before connecting regulators. Also, ensure that the pressure regulator thumb screws are backed out to full release position when connecting the regulators to the cylinders.
- c. The hoses are to be connected to the regulators but not to the torch, leaving the ends of the hoses open. A 50-foot section of 3/8-inch twin hose should be sufficient to work at depths of 25 to 30 feet; however, see [Table E-3](#) for information on setting pressure and selecting hose sizes. Avoid excessive hose length since it causes the pressure to drop and can get in the diver's way. Like all fuel gases which are odorless by nature, a chemical has been added to aid in detecting leaks by smell.

**E-4.4.1 Purging the Hoses.** The fuel and oxygen lines should be purged by holding the open-ended hoses in one hand, pointed away from any open flame or personnel. Use the other hand to slowly open cylinder valves. When the valves are open, screw in the thumb screw on the fuel regulator enough to purge the line and blow out any foreign matter; the thumb screw should then be backed out to stop the flow. Repeat this procedure with the oxygen line.

## S0300-BB-MAN-010

**Table E-3. Regulator Gauge Settings<sup>1</sup>**

<b>Depth</b>	<b>Minimum Water Temperature</b>	<b>Minimum Bottle Pressure when using Hydrogen Double Stage Regulators</b>	<b>Minimum Bottle Pressure when using Acetylene Single Stage Regulators</b>
(fsw)	°F	(psig)	(psig)
10	28	34	19
20	28	39	24
30	28	43	28
40	28	47	32
50	28	52	37
60	28	56	41
70	30	60	45
80	35	65	50
90	38	69	54
100 <sup>2</sup>	40	73	58
125	50	84	69
150	60	95	80
175	66	106	91
200	75	117	102

1. Based on manufacturer's data.

2. MAPP gas will turn to a liquid form at depths greater than 100 FSW, if not heated.

## S0300-BB-MAN-010

**E-4.5 Underwater MAPP Gas Cutting Torches.** A standard oxy-acetylene oxygen cutting torch can be used for cutting with MAPP gas underwater. [Figure E-4](#) shows a standard surface cutting torch with the underwater spacer sleeve, controls for oxygen and MAPP gas, the cutting oxygen control and the FS or stinger cutting tip. The torch must be attached to hoses which carry the gases and the torch is clearly marked so that the oxygen hose and the MAPP gas hose will be connected with the proper gas passages within the torch. As an additional safeguard, the threads which connect each of the hoses are not compatible, so that a hose carrying MAPP gas would not fit the connection to an oxygen passage.

As illustrated in [Figure E-4](#), the cutting tip is a two-piece, standard pressure tip with a fine spline which fits onto the standard acetylene oxygen cutting torch. Selection of the proper tip size depends on the thickness of the metal; refer to [Table E-4](#) for the proper size to be used with various plate thicknesses. The cutting tip has a preheat perimeter which is equally divided into 18 to 26 milled slots and displaces water more evenly than the 8 holes of the standard pressure tip. For that reason, the cutting tip preheats faster and gives quicker starts. It is especially recommended when cutting is to be done with a tip spacer sleeve.

**Table E-4. Recommended Cutting Tip Sizes**

Plate Thickness	1/4-1 in.	1 1/4-2 3/4 in.	3-4 in.	6-5 in.
<b>Cutting Tip Sizes</b>				
FS	#52	#46	#42	#38
Stinger	# 4	# 5	# 6	# 6

The spacer sleeve, shown in [Figure E-4](#) clamps over the cutting tips and is used to keep the cutting tips at the proper distance from the work, which should be a minimum of 3/16 inch and a maximum of 1/4 inch for the cutting tip. This sleeve should also be perforated to allow water to circulate around the cutting tip.

After the tip and spacer sleeve are seated, the flame should be lit and adjusted. It is necessary to set the recommended regulator pressures with the flame burning and the cutting oxygen valve wide open. Work should be stopped at once when any cylinder pressure drops below the recommended operating pressure. The preheat flame, produced from the mixture of MAPP gas and oxygen, supplies heat to start the cut and maintains the cutting temperature. The central oxygen jet accomplishes the actual cutting by oxidizing and blowing out a narrow band of metal to produce the kerf.

The gas controls typically incorporated in the cutting torches are shown in [Figure E-4](#). The torch is to be connected to the hoses and the working pressure must then be set. Before seating the cutting tip, purge the torch with each gas separately.

S0300-BB-MAN-010

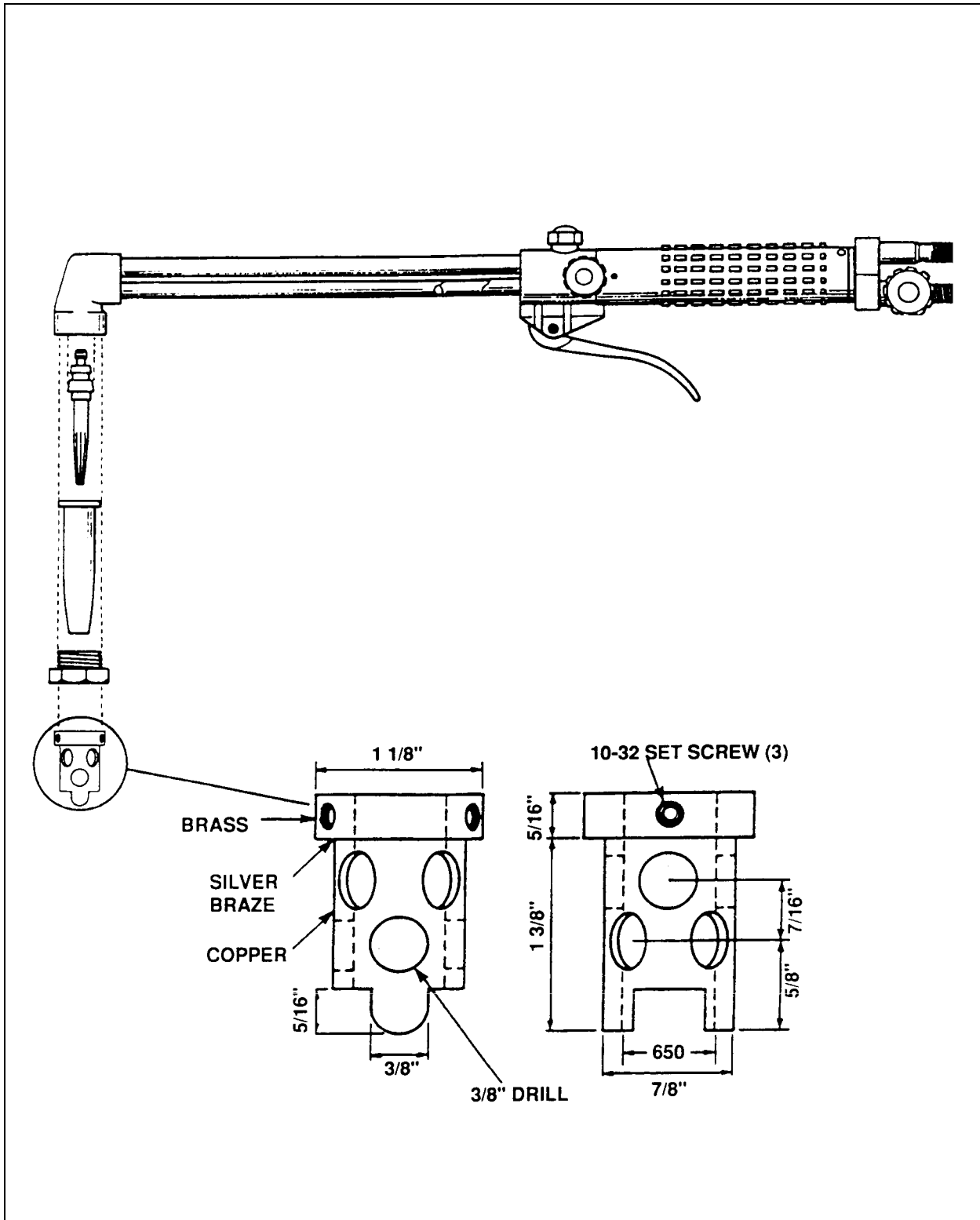

Figure E-4. Standard Surface Cutting Torch with Underwater Spacer Sleeve.

## S0300-BB-MAN-010

Torch Igniter. A hand mechanical igniter should be used for lighting the torch. This simple tool is safer than an electrical igniter and is equally effective.

After the steel has been pierced, cutting can proceed at approximately the same speed as it does above water. If loud popping sounds are heard, other than those made by hot slag forming in the water, add a small amount of preheat oxygen to the flame. This same procedure also applies to edge starts.

It is important to recall that the ocean is a giant heat-sink and has a cooling action at least 40 times greater than that of air and therefore, a light thickness of steel will require as much preheating as a heavy thickness because of the rapid heat transfer through lighter steel.

#### E-4.6 Igniting the Torch Above Water

##### NOTE

Before igniting the cutting torch, review the safety procedures in [Appendix D](#).

**E-4.6.1 Preparation.** An FS-52 or Stinger-4 cutting tip is recommended for underwater cutting of material up to one inch thick. Seat the cutting tip in the high-capacity torch and set a cutting tip spacing sleeve for 1/4 inch coupling distance. Set the MAPP gas regulator pressure at 20 psig and the oxygen regulator pressure at 60 psig. Once at the work site maintain MAPP gas and oxygen pressures in accordance with [table E-5](#).

**E-4.6.2 Ignition.** The following procedure is to be used when igniting the cutting torch in air:

- a. Open the fuel valve approximately 1/4 turn and crack the preheat oxygen valve.
- b. Light the torch with a sparklighter.
- c. Bring the flame up to a maximum by opening the preheat oxygen valve and adding fuel until a stable preheat flame is maintained at the tip end with the fuel valve nearly wide open.

The flame should be burning at a high volume and velocity in the atmosphere and there should be some adjustment left on the fuel and preheat oxygen valves so that the diver can make last minute adjustments as desired at work depth. The preheat flame should be adjusted correctly before the torch is lowered to the diver. When the flame has been adjusted above the surface, put the torch approximately 10 inches below the surface of the water and open the cutting oxygen valve wide open. If flames play around on the surface, add preheat oxygen until these flames disappear. The torch is now ready to be lowered to the diver.

## S0300-BB-MAN-010

**Table E-5. Recommended Pressure Settings and Hose Size Selection Chart**

<b>WATER</b>		<b>MAPP GAS</b>		
<b>Depth (FSW)</b>	<b>Pressure (psi)</b>	<b>Pressure (psi)</b>	<b>Hose Diameter (in)</b>	<b>Hose Length (ft)</b>
10	4.5	25	1/4	50
20	9.0	25	1/4	50
30	13.5	25	1/4	50
40	18.0	30	1/4	50
50	22.5	35	5/16	75
60	27.0	40	5/16	75
70	31.0	45	5/16	100
80	35.5	50	5/16	100
90	40.0	55	3/8	125
100	45.0	60	3/8	125

**OXYGEN**

Pressure in psig for Plate Thickness of:

<b>Depth (FSW)</b>	<b>Pressure (psi)</b>	<b>1/4-1" (psi)</b>	<b>1/4-2 3/4" (psi)</b>	<b>3-4" (psi)</b>	<b>5-6" (psi)</b>	<b>Hose Diameter (in)</b>	<b>Hose Length (ft)</b>
10	4.5	60	70	80	90	5/16	50
20	9.0	60	70	80	90	5/16	50
30	13.5	60	70	80	90	5/16	50
40	18.0	65	75	85	95	5/16	50
50	22.5	70	80	90	100	5/16	75
60	27.0	75	82	95	105	3/8	75
70	31.0	80	90	100	110	3/8	100
80	35.5	85	95	105	115	3/8	100
90	40.0	90	100	110	120	3/8	125
100	45.0	95	105	115	125	3/8	125



## S0300-BB-MAN-010

**E-4.7 Lowering the Ignited Torch.** The ignited torch may be lowered to the working location in one of two ways:

- a. Carrying the Torch Below - In moderate or shallow depths and easily accessible locations, the ignited torch may be carried below by hand. The diver should be prepared to make adjustments to the flame to compensate for increased hydrostatic pressure during descent.
- b. Lowering the Ignited Torch - In shallow depths and locations, where it is absolutely certain that the flame can be kept clear of all hoses, lines, diver's dress, helmet and other equipment or personnel, the ignited torch may be lowered directly to a point within reach of the diver. Never lower an ignited torch until it is certain that the diver is ready and watching for it and is in the clear in such a position that the torch flame cannot possibly strike his helmet, suit or umbilical.

It is the responsibility of the diver's tender to see that the correct pressures are maintained at the regulators. When the job has been completed, the diver should shut off the MAPP gas valve first and release the oxygen trigger; however, let preheat oxygen blow until the torch is removed from the water. This will keep the preheat parts from becoming clogged with foreign matter. Clean the torch and tips if it is suspected that clogging may have occurred.

**E-4.8 Underwater Cutting.** The cut may be started on the edge of the plate or in [Figure E-5](#).

**E-4.8.1 Starting the cut at the edge of a plate.** To start the cut at the edge of a plate, proceed as follows:

- a. Hold the torch head over the corner of the plate so that the preheat flames can heat a spot on the edge. Small sparks flying from the steel will indicate that the metal is hot enough to start the cut (see [Figure E-5](#)).
- b. Start the cut by pressing on the cutting lever and directing the cutting jet onto the hot spot. Better results will usually be obtained by opening the cutting jet about halfway for a few seconds at the start.

**E-4.8.2 Starting the cut at the central portion of a plate.** The cut may be started in the middle of a flat plate by "blowing through." The recommended procedure is as follows:

- a. Hold the torch tip at one spot on the plate until it is brought to heat. [Figure E-6](#) shows the torch positioned for starting a cut in the middle of a flat, horizontal plate.
- b. Turn on the cutting jet gradually, at the same time raising the torch head slightly so that slag will not blow back into the tip. The two motions should be simultaneous.

S0300-BB-MAN-010

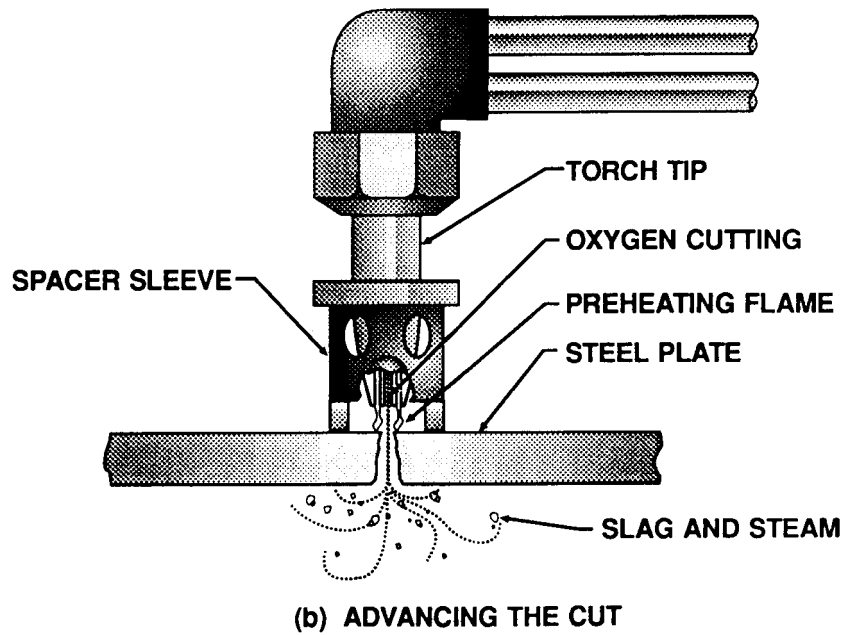
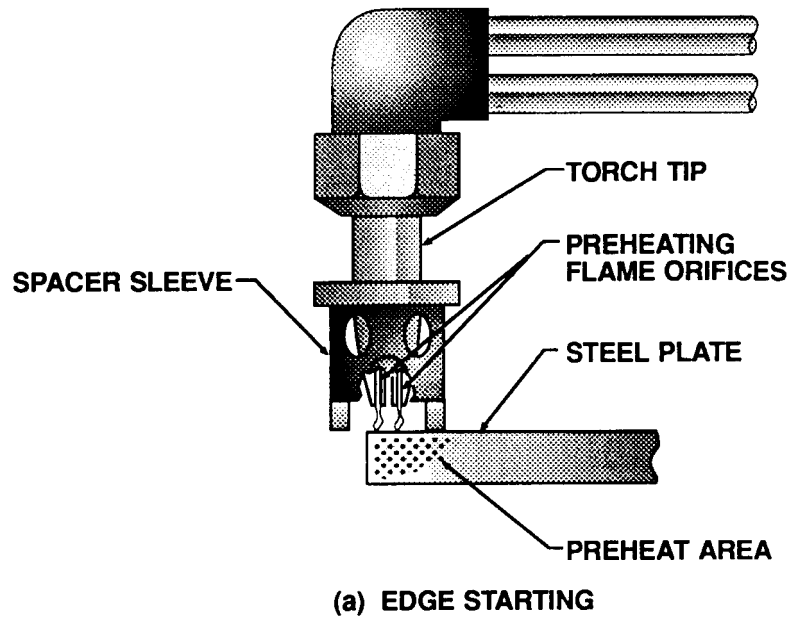

Figure E-5. Starting the Cut at the Edge of a Plate.

S0300-BB-MAN-010

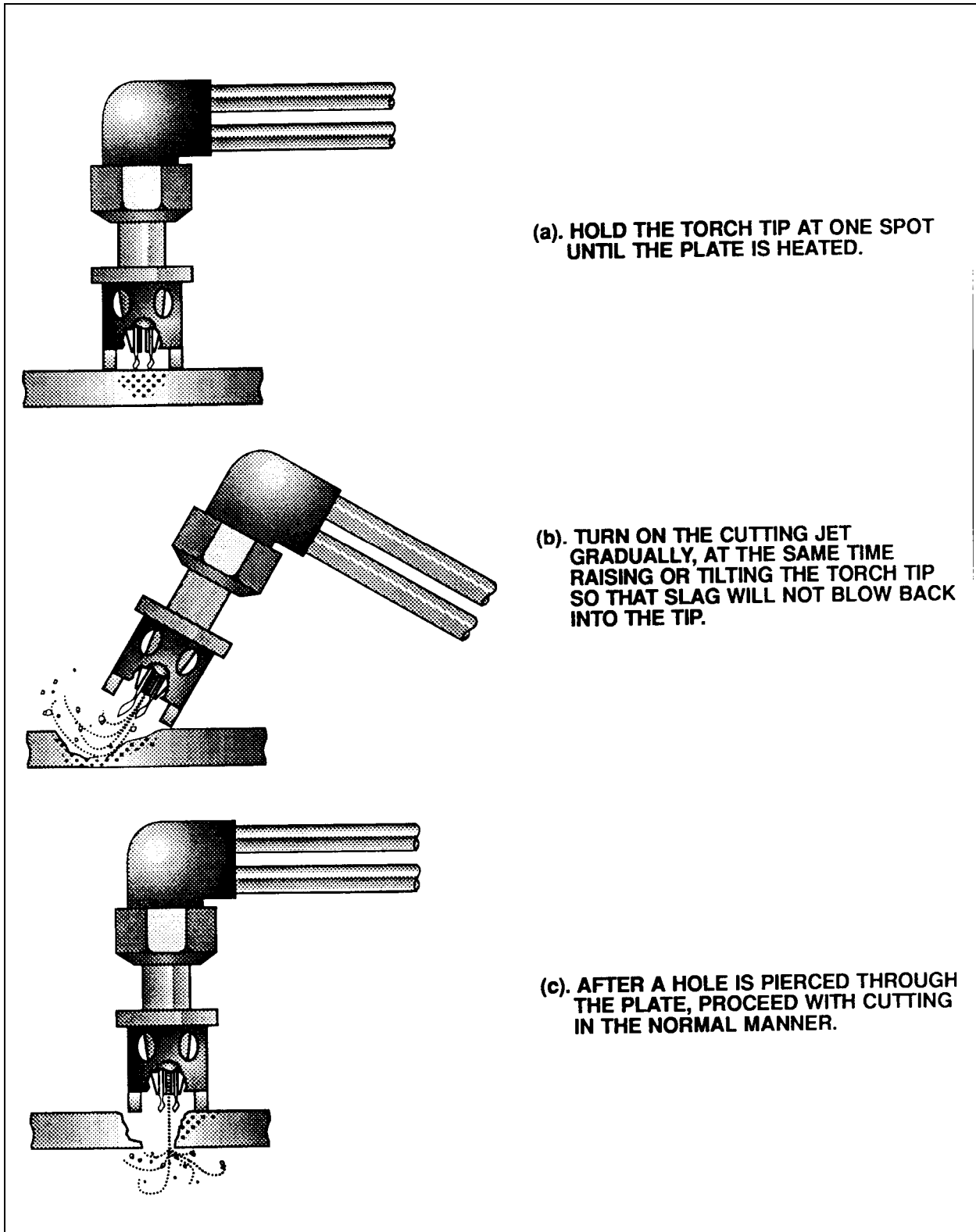

Figure E-6. Starting a Cut in the Central Portion of a Plate.

## S0300-BB-MAN-010

**E-4.8.3 Advancing the cut.** The cut is advanced by moving the torch at a steady, uniform rate of speed along the line of cut, fast enough to keep the cut going, but slow enough to cut completely through the metal. When the torch is advanced too slowly, the steel will cool below the ignition temperature and the cutting action will stop. The diver has “lost the cut” and will have to restart the cutting action. When the torch is advanced too rapidly, again the cut will not be completely through. The skipped spots (hangers) will be very hard to cut out. When the cut has been lost, it may be restarted by going back 1/2 to 3/4 inch and start a new kerf to one side of the old cut. As shown in [Figure E-7](#), the purpose of this is to be sure that the cut is complete.

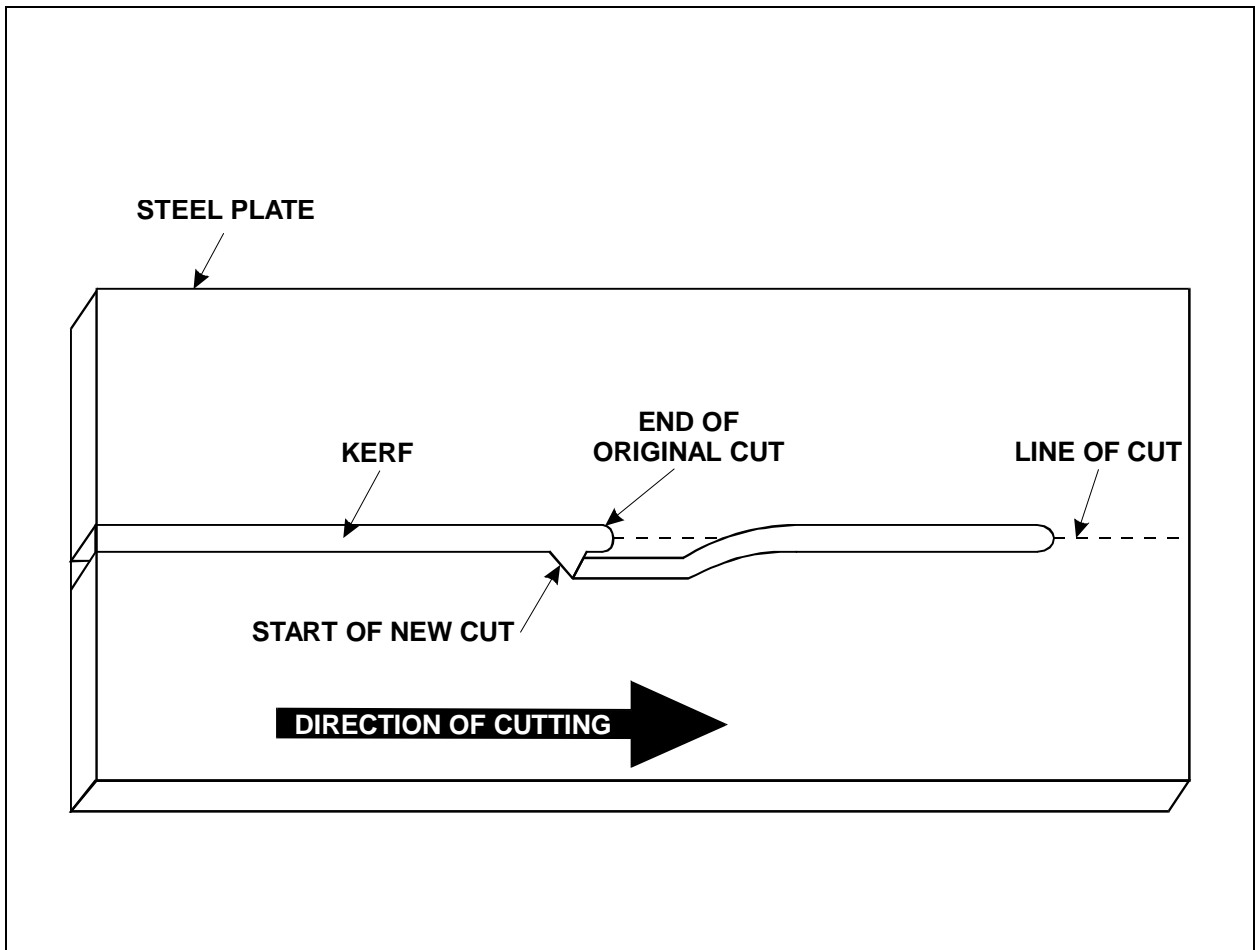

Figure E-7. Restarting the Cut.

## S0300-BB-MAN-010

**E-5 UNDERWATER WELDING****CAUTION**

Due to the flammability and toxicity of fumes from the waterproofing compounds, waterproofing must be conducted in a well ventilated space, clear of any open flames or spark-producing machinery.

When commercially produced waterproofed wet welding electrodes are not available, surface welding electrodes can be used if waterproofed. Some above-water electrodes will give satisfactory performance underwater if properly prepared and deposited by a skilled diver. The electrodes listed in [Table E-6](#) are suitable for on-site waterproofing. For positional welding underwater, E6013, E7014, E7016 and stainless steel electrodes of 1/8-inch diameter are suitable.

**E-5.1 Waterproofing Surface Electrodes.** Unlike commercially manufactured wet welding electrodes, it is necessary to waterproof the flux coating of surface welding rods. This is accomplished by dipping the electrode in one of the suitable waterproofing solutions listed in [table E-6](#). One or two dips may be required, depending on viscosity of waterproofing material. Be sure to completely cover all of the flux coating. One or two dips are required because when the waterproof coating is inadequate, water forced into the interstices will turn to steam when the arc is struck and will blow off the coating. The waterproofing coatings must be thoroughly dry before applying additional coatings and also before they are used. The grip ends of the electrodes should be cleaned to prevent the waterproofing material from interfering with electrical contact between the electrodes and holder. It is desirable to send the diver only a few electrodes at a time since waterproofing protects the electrode covering for a limited amount of time.

S0300-BB-MAN-010

**Table E-6. Surface Welding Electrodes Suitable for Wet Welding**

1/8", 5/32" & 3/16" E6013, E7014, E7016 & E7018	Carbon steel	American Welding Society, AWS A5.1
1/8", 5/32" & 3/16" E309, E310 & E312	Stainless steel	American Welding Society, AWS A5.4
1/8" & 5/32" ENiCrFe-2, ENiCrFe-3 & ENiCrMo-3	High nickel	American Welding Society, AWS A5.1
WATERPROOFING MATERIALS		
Epoxy 152	MIL-P-24441	
Lea-Lac 30-L2093		
Non-petroleum-based, clear, polyurethane		

## S0300-BB-MAN-010

**E-5.2 Preparation for Underwater Shielded Metal Arc Welding.** Standard electrode holders designed for surface use may be used when underwater holders are not available, **but only in an extreme emergency situation.** It must be realized that these holders were never intended to be used underwater and therefore are not adequately insulated. **The importance of fully insulating all current-carrying parts cannot be overemphasized.** See [Table E-7](#) for amperage settings to depths of 50 FSW.

When preparing for underwater welding operations, several factors must be considered before welding actually begins. Adequate electrode preparations must be made. Lack of attention to detail here may well result in wasted diving time. For best results, follow the guidelines below:

- a. Avoid handling the flux coating with fingers.
- b. Before the dipping process, E7014 and E7016 electrodes shall be removed from their containers and placed into an oven. The electrode shall be heated to 300°F and held at temperature for 4 hours. The oven temperature shall then be reduced to 150°F. The electrodes must remain in the oven until dipping operation takes place.
- c. It is important that the work be accomplished in an area of low humidity.
- d. Mix the waterproofing according to the manufacturer's instructions in a clean container.
- e. Attach handling clips to the bare metal end of the electrode before dipping. Suitable clips can be fashioned using alligator clips with holes drilled into one end and "S" hooks made from small wire.
- f. Dip warm electrodes vertically into the waterproofing solution. Wait until no more gas bubbles generated by the electrode appear in the dipping container. Only then remove the electrodes from the container. This ensures a sound, uniform waterproof coating on the flux covering.
- g. Dip electrodes once or twice as desired, covering all of the flux coating each time. If dipping more than one electrode at a time, do not allow their surfaces to touch each other.
- h. Hang electrodes vertically in a warm, dry area. This allows excess waterproofing, not absorbed into the flux coating, to run off evenly and form a slight bubble on the electrode tip. Leave the bubble attached. This will be removed when the diver strikes the arc.
- i. Allow electrodes to fully dry before re-dipping.
- j. Follow the same procedure for E308 and E310 electrodes.
- k. Do not heat E6013 electrodes prior to dipping. To do so would dry out the water-based flux adhesive rendering the flux useless.

## S0300-BB-MAN-010

**Table E-7. Recommended Amperage Settings for Wet Welding to Depths of 50 FSW**

Type	Electrode		Welding Position			Arc <sup>1</sup> Voltage
	Size inch	Horizontal Amps	Vertical Amps	Overhead Amps		
E6013	1/8	130-140	130-140	130-135	25-35	
	5/32	150-180	150-180	150-170	26-36	
E7016	1/8	140-150	140-150	130-140	25-35	
	5/32	160-200	160-200	160-180	26-36	
E7014	1/8	140-150	140-150	130-145	25-35	
	5/32	170-200	170-200	170-190	26-36	
	3/16	190-240	190-240	190-230	28-38	
E3XX	1/8	130-140	135-140	125-135	22-30	
High Nickel	1/8	130-150	125-145	125-145	22-30	

1. Arc voltage is the voltage recorded as welding is in progress. Tong meter amperage should also be recorded as welding is in progress.



## S0300-BB-MAN-010

- l. Waterproofing compounds drying times vary from minutes to several days.
- m. Never, under any circumstances, put a waterproofed electrode into a warm oven.

The coating process should produce a hard, uniform surface without lumps or blisters. The coating should not dissolve or deteriorate when exposed to salt water. If this occurs, the cause is usually incorrect waterproofing technique.

## E-6 LOSS OF VOICE COMMUNICATIONS

While operating under the guidelines of this chapter; contingency plans shall be adopted for loss of voice communications between tender and diver: Supervisors shall establish a clear line-pull command system with return confirmation for SWITCH ON and SWITCH OFF.

## E-7 FRICTION STUD WELDER

Historically, friction welding has been restricted to large heavy equipment permanently installed in workshops and stud attachment has involved an electrical process with a power source capable of delivering several hundred amps from a three-phase power supply.

The SEASTUD portable friction welder, [Figure E-8](#), is a lightweight, hand-held air-tool which will attach various size studs to metals and other materials.

**E-7.1 Principle of Operation.** The friction welding process produces a weld by using the heat generated between a rotating stud and the fixed metal. The heat generated at the junction of the rubbing components allows the interface metals to become plastic and flow away radially from the point of contact, at the same time removing any surface contaminants. When the interface has achieved a clean, high-temperature condition, the two components forge together. Rotation is stopped at this point and the bond is consolidated. All this occurs within seconds without protective atmospheres, gases or flux. Welding times vary from 1-40 seconds, depending on the materials, the stud size and the metallurgical properties involved. It is an ideal tool to install patches.

**E-7.2 Advantages.** The following advantages are associated with the SEASTUD:

- a. The SEASTUD is pneumatically powered and is independent of high voltage power supplies.
- b. Minimal surface preparation required as the process is unaffected by many surface contaminants.
- c. The operating technique is very simple and readily mastered.
- d. Only seconds are required to achieve a weld.

## S0300-BB-MAN-010

- e. There are considerable metallurgical advantages with the use of this method. Defects normally associated with weld metal, such as porosity, slag inclusions, cracking arising from arc irregularities are not possible therefore rapid solidification can occur.

**E-7.3 Equipment Requirements.** The term, hand-held, as used to describe this unit, is a somewhat misleading as the unit is merely carried to the job site by hand. To operate the SEASTUD friction welder, it must be locked in place by one of a variety of clamps which are supplied with the unit. These are either mechanical, electro-magnetic or vacuum and will hold the unit onto a variety of surfaces such as steel, ferrous or non-ferrous, concrete and wood.

**E-7.3.1 Equipment Details.** Equipment details are as follows:

- a. Welding gun - SEASTUD S1004

Weight: in air	24.2 lb
In water	13.2 lb
Required air supply:	150 SCFM at 125 psi <sup>1</sup>
Stud Capacity: Diameter	3/16-inch to 5/8-inch
Length	3/8-inch to 7.9-inch

Studs are available in low-strength carbon steel, stainless steel and commercial quality aluminum.

The clamps, called **reaction clamps**, are designed for quick deployment and release and are described as follows:

- a. Magnetic

Power required	35-volts DC
Pulling force	3,520 pounds <sup>2</sup>

- b. Vacuum (Air Eductor System)

Pulling force	5,280 pounds <sup>2</sup>
---------------	---------------------------

- c. Mechanical

Beam Clamps  
Pipe Clamps

---

1. Air requirements are at the welding gun working depth  
2. Based on manufacturer's data

S0300-BB-MAN-010

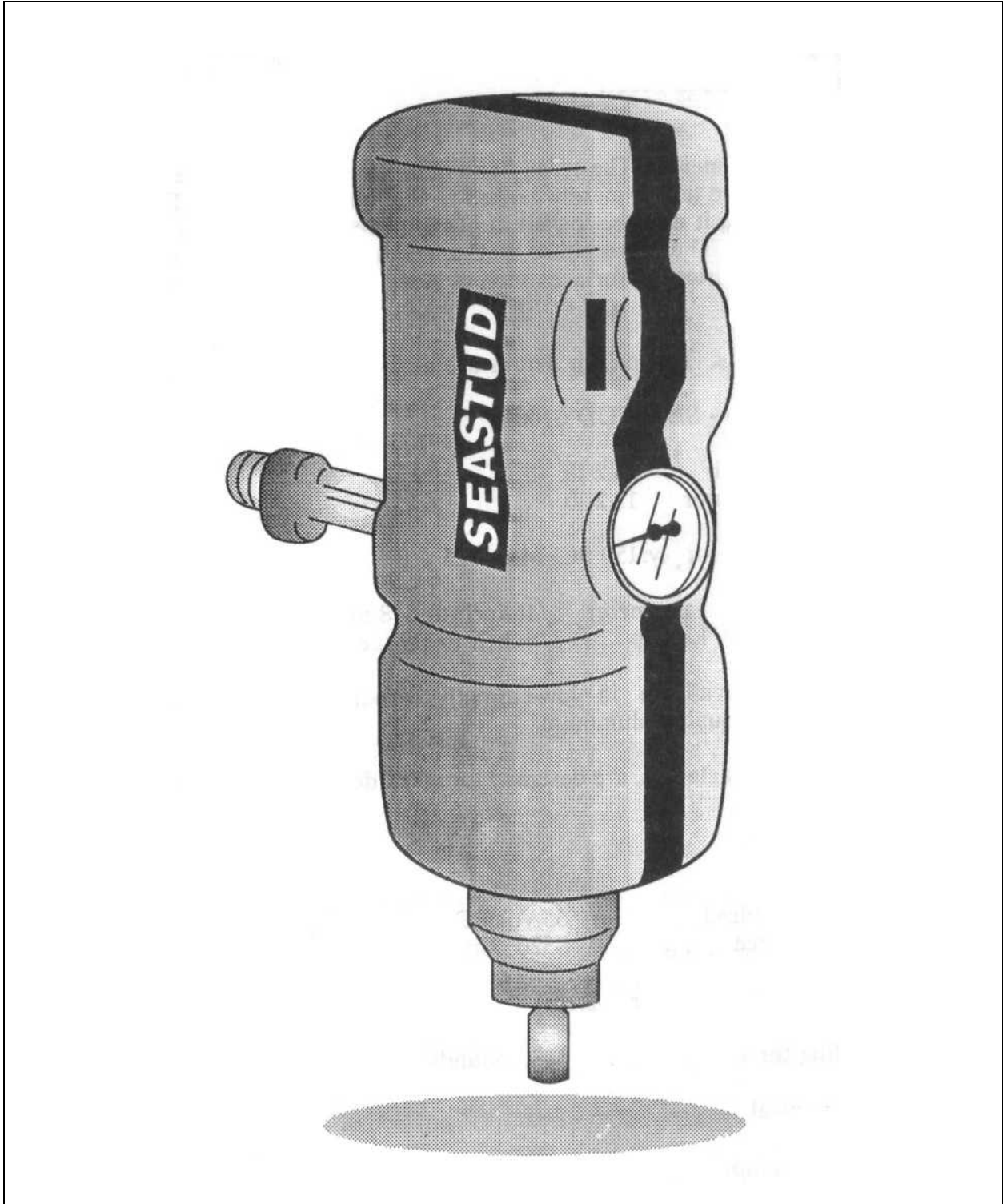

Figure E-8. Friction Stud Welder.

S0300-BB-MAN-010

---

## GLOSSARY

---

### NOTE

The following Glossary of Terms is intended to aid the reader in understanding the materials, tools and processes involved in underwater welding and cutting. Most of the definitions were obtained from the approved list of definitions published by the American Welding Society (AWS).

**Alternating current (AC).** Electricity which reverses its direction periodically. For cycle current, the current goes in one direction and then in the other direction 60 times in the same second, so the current changes direction 120 times in one second.

**Arc Column.** The result of an electric current passing between an electrode and metal to be cut or welded.

**Arc Cutting.** A group of cutting processes which melts the metals to be cut with the heat of an arc between an electrode and the base metal.

**Arc Oxygen Cutting.** See preferred term Oxygen Arc Cutting.

**Arc Voltage.** The voltage across the welding arc.

**Arc Welding.** A group of welding processes which produces coalescence of metals by heating them with an arc, with or without the application of pressure and with or without the use of filler metal.

**Austenitic Welding Electrodes.** Refers to that group of stainless steel electrodes having non-magnetic properties and a high degree of corrosion resistance. Chromium and nickel are the primary alloying elements of the austenitic stainless steels. These electrodes conform to Military Specification MIL-E-22200/2 and AWS Specification A5.4. Type MIL-310-15/16 is one austenitic stainless electrode which has been applied successfully underwater.

**Covered Electrode.** A composite filler metal electrode consisting of a core of a bare electrode or metal-cored electrode to which a covering sufficient to provide a slag layer on the weld metal has been applied. The covering may contain materials providing such functions as shielding from the atmosphere, deoxidation, and arc stabilization and can serve as a source of metallic additions to the weld.

**Cut/Burnoff Ratio.** Linear inches of metal cut per inch of electrode consumed.

**Cutting Nozzle.** See preferred term Cutting Tip.

**Cutting Spacer Sleeve.** That part of the MAPP gas underwater cutting torch that fits over the cutting tip to keep the tip at the proper coupling distance from the work.

## S0300-BB-MAN-010

**Cutting Tip.** That part of an oxygen cutting torch from which the gases issue.

**Cutting Torch.** A device used in oxygen cutting for controlling and directing the gases used for preheating and the oxygen used for cutting the metal.

**Direct Current (DC).** Electric current which flows only in one direction. It is measured with an ammeter.

**Electrode Holder.** A device used for mechanically holding the electrode and conducting current to it.

**Electrode Lead.** The electrical conductor between the source of arc welding current and the electrode holder.

**Fillet Weld.** A weld of approximately triangular cross section joining two surfaces approximately at right angles to each other in a lap joint, T-joint, or corner joint.

**Flashback.** A recession of the flame into or back of the mixing chamber of the torch.

**Flashback Arrestor.** A device to limit damage from a flashback by preventing propagation of the flame front beyond the point at which the arrestor is installed.

**Flux.** Material used to prevent, dissolve, or facilitate removal of oxides and other undesirable surface substances.

**FS Cutting Tip.** A two-piece, fine spline, standard pressure tip which is used with the MAPP gas cutting torch. It has a heavy preheat flame and usually gives a fast start.

**FSW.** Depth abbreviation for Feet Salt Water.

**Gas Bubble.** The result of the combustion of the electrode and the dissociation of water which is created when the arc is struck under water. If the gas bubble breaks, water will quench the arc.

**Gas Cutting.** See preferred term Oxygen Cutting.

**Groove Weld.** A weld made in the groove between two members to be joined.

**Ground Connection.** An electrical connection of the welding machine frame to the earth for safety.

**Hanger.** Area of incomplete burn-through left in the kerf after a cutting process.

**Inconel Welding Electrodes.** Nickel alloy electrodes conforming to Military Specification MIL-E-22200/3 and AWS Specification A5.11. These high nickel electrodes have properties similar to the austenitic steel electrodes. AWS Class E NiCrMo-5 has undergone experimental evaluation underwater.

## S0300-BB-MAN-010

**Kerf.** The width of the cut produced during a cutting process.

**Kerie Cable.** A flexible spiral cable with a hollow core enclosed in plastic. Consumable metal strands of the cable have a high carbon content which burns more slowly than mild steel. Supplied in 50 and 100-foot lengths and gives 45 minutes of non-stop cutting at very high speeds. Manufactured in 3 different diameters.

**Manipulative Technique.** A method of arc welding in which the electrode is maneuvered under water and a constant arc is maintained. See Weave Bead.

**Manual Oxygen Cutting.** A cutting operation performed and controlled completely by hand.

**MAPP Gas. Methylacetylene Propadiene.** This gas, which is used for underwater cutting, was developed by Dow Chemical Company. "MAPP Gas" is a registered trademark.

**Metal Arc Cutting.** An arc cutting process which severs metals by melting them with the heat of an arc between a metal electrode and the base metal.

**Molten Weld Pool.** The liquid state of a weld prior to solidification as weld metal.

**Oxy-acetylene Cutting.** A group of oxygen cutting processes used to sever metals by means of the chemical reaction of oxygen with the base metal at elevated temperatures, the necessary temperature maintained by means of gas flames obtained from the combustion of acetylene with oxygen.

**Oxygen Arc Cutting.** An oxygen cutting process used to sever metals by means of the chemical reaction of oxygen with the base metal at elevated temperatures. The necessary temperature is maintained by an arc between a consumable tubular electrode and the base metal.

**Oxygen Cutting.** A group of cutting processes used to sever or remove metals by means of the chemical reaction of oxygen with the base metal at elevated temperatures. In the case of oxidation-resistant metals, the reaction is facilitated by the use of a chemical flux or metal powder.

**Oxygen Lance.** A length of pipe or tube filled with ferrous wires or rods held in place by crimped ends of the tube. Used to convey oxygen to the point of cutting in oxygen lance cutting.

**Oxygen Lance Cutting.** An oxygen cutting process used to sever metals with oxygen supplied through a consumable lance; the flame to ignite the lance is usually an oxy-acetylene torch.

**Oxygen Lancing.** See Oxygen Lance Cutting.

**Pass.** A single progression of a welding or surfacing operation along a joint, weld deposit, or substrate. The result of a pass is a weld bead, layer, or spray deposit.

**PSI.** Pounds per square inch.

S0300-BB-MAN-010

**Puddle.** See preferred term Molten Weld Pool.

**Self-Consuming Technique.** A method of arc welding in which the electrode is dragged across the work with significant amount of pressure.

**Shielded Metal Arc Cutting.** A metal arc cutting process in which metals are severed by melting them with the heat of an arc between a covered metal electrode and the base metal.

**Shielded Metal Arc Welding.** An arc welding process which produces coalescence of metals by heating them with an arc between a covered metal electrode and the work. Shielding is obtained from decomposition of the electrode covering. Pressure is not used and filler metal is obtained from the electrode.

**Spatter.** In arc and gas welding, the metal particles expelled during welding and which do not form a part of the weld.

**Stinger.** Electrode holder.

**Stick Welding.** Welding used in Shielded Metal Arc Welding.

**Straight Polarity.** The arrangement of direct current arc welding leads wherein the work is the positive pole and the electrode is the negative pole of the welding arc.

**Stringer Bead.** A type of weld bead made without appreciable weaving motion. See also Weave Bead.

**Torch.** See preferred term Cutting Torch.

**Torch Tip.** See preferred term, Cutting Tip.

**Undercut.** A groove melted into the base metal adjacent to the toe or root of a weld and left unfilled by weld metal.

**Weave Bead.** A type of weld bead made with transverse oscillation.

## S0300-BB-MAN-010

---

**INDEX**

---

AC power .....	D-4
Adapter	
cutting torches .....	2-21
Advantages and Disadvantages	
exothermic process .....	2-5, 2-25
kerie cable .....	2-34
Alternate cutting technique	
in poor visibility conditions .....	2-15
Always List .....	D-11
Amperage .....	4-13
Current .....	4-13
Pressure .....	4-13
Resistance .....	4-13
Settings for Wet Welding .....	E-25
tong meter .....	4-13
Arc	
protective shield .....	3-3
voltage (also closed-circuit voltage) .....	3-7
Arcwater Cutting .....	E-1
Arcwater torch .....	E-2
Barriers	
mechanical .....	3-2
Blow holes	
see Warning .....	2-34
Burn Bars	
Thermic Lance .....	E-5
Seeler Enterprises LU-001 Exothermic Cutting Tool (Kerie Cable).....	1-2, 2-33 thru 2-43
Adapter, double male, 6.4mm x 3.2mm (1/4-inch x 1/8-inch) .....	2-35
Control Panel Set-up .....	2-36
Cutting Techniques .....	2-40
Emergency Off Procedures .....	2-43
Equipment Tender Responsibility .....	2-43
Extension Lead .....	2-35
Oxygen Pressure .....	2-41
Oxygen Regulator Settings .....	2-41
Relighting Underwater.....	2-43
Cofferdams And Caissons	
brief description .....	3-2
Compressed Gas	
Safety Precautions .....	D-10
Conditions Adverse to Underwater Welding .....	3-8
Cutting	
Shielded Metal-arc .....	2-44



## S0300-BB-MAN-010

Cutting and welding	
“C”-type ground clamps .....	4-8
equipment .....	4-21
Leak Detector .....	4-8
tong meter .....	4-8
Underwater Cutting Torches .....	4-8
Cutting Techniques	
exothermic .....	2-28
exothermic (cast iron, and non-ferrous metals) .....	2-30
exothermic (concrete, rock and non-conductive materials).....	2-31
steel-tubular (cast iron, and non-ferrous metals) .....	2-18
steel-tubular (thick plate) .....	2-11
steel-tubular (thin plate) .....	2-15
underwater shielded metal-arc .....	2-45
Cutting-gas	
Pressure .....	2-11
DC Welding Generators.....	2-2, 4-15, D-5
Disadvantages of the Steel-Tubular Electrode .....	2-5
Diving Equipment	
MK 1 .....	4-1
MK 12 .....	4-1
Superlite-17 .....	4-1
Documentation Matrix .....	A-1
Drag technique .....	2-12, 2-46
SMA cutting.....	2-44
Electric current flow	
as it affects the weld pool .....	3-3
Electricity Underwater .....	D-4
AC power .....	D-4
DC power .....	D-4
Electrode amperage requirements	
steel-tubular cutting .....	2-6
Electrode holders .....	D-6
Electrode selection	
field-expedient method .....	3-3

## S0300-BB-MAN-010

Electrodes	
Andersen Easy Weld .....	3-7
Broco Sof-Touch .....	3-7
Broco SS .....	3-7
E6013 .....	3-4
E7014 .....	3-4, 3-7
E3XX .....	3-7
after exposure to salt water .....	3-25
Seajet .....	2-22
Steel Tubular .....	2-4, 2-5, 2-10, 2-12
storage .....	2-18
Ultrathermic .....	2-22, 2-23
Exothermic Cutting	
Kerie Cable .....	2-33
Exothermic Electrode Consumption Guide, Table 2-5 .....	2-26
Exothermic electrode cutting	
oxygen requirement .....	2-25
Exothermic Electrodes .....	1-2, 2-14, 2-18, 2-22, 2-23, 2-25, 2-30
warnings .....	2-22
Explosive Gases .....	D-1
Fillet Weld .....	3-10
Fillet Welding	
in the horizontal position .....	3-14
in the overhead position .....	3-17
in the vertical position .....	3-17
where there is poor fit-up .....	3-20
Flashback Arrestor	
inspection .....	2-18
Flaw detection .....	4-8
Flaw detection device .....	4-8
Flux coating	
purpose .....	2-2
Friction stud welder	
SEASTUD .....	E-26
Gas Manifolds .....	4-17
Gouging .....	E-4
Ground .....	D-7
Ground clamp .....	4-8
Ground clamp position	
See Warning .....	2-27, D-7
Ground-fault Detections .....	D-7
Grounding clamps	
C-type .....	2-6
Grounding the Work .....	2-11, 2-27
procedures .....	3-13

## S0300-BB-MAN-010

Growth-encrusted metal	
(see Note) .....	2-11
Hole Piercing	
exothermic process .....	2-31
steel-tubular .....	2-15
Hose	
care during storage .....	2-18
Hose care	
during storage .....	2-33
Hose size	
gas volume .....	2-25
Hydrocarbons .....	D-10
Insulating sleeve	
Kerie Cable .....	2-35
Introduction .....	2-1
Job-site	
pre-inspection .....	1-1
Joint Fit-up .....	3-13
Knife Switch .....	4-16
Power On/Off .....	2-35
Leak detector .....	4-8
Lessons learned	
recording .....	3-14
Loss of Communications	
procedures for .....	2-43
Magnetic Particle .....	4-8, 4-21
Maintenance	
post-dive .....	2-18, 2-33
Manipulative or weave technique	
SMA .....	3-20
MAPP Gas .....	D-13, E-10
Marine Growth .....	2-11
Material Consumption	
exothermic cutting .....	2-25
steel-tubular cutting .....	2-6, 2-11
Materials Required	
Kerie cable cutting .....	2-35
Shielded metal-arc cutting .....	2-44
Materials for Underwater Shielded Metal Arc Welding .....	3-6
Mechanical Barriers	
Cofferdams and Caissons .....	1-2, 3-2
Metric Conversion Factors .....	B-1
Mini-habitats .....	3-2
Modified technique	
for the advanced operator .....	3-16
Never List .....	D-10

## S0300-BB-MAN-010

Operating principles	
Shielded Metal-Arc (SMA) .....	2-44
Oxygen	
Safety precautions .....	D-12
Oxygen-Arc Cutting Torches .....	4-17
Oxygen-Arc Cutting .....	1-2, 2-1 thru 2-3, 2-7 thru 2-9, 2-18 thru 2-20, 2-40
operating principles.....	2-3
Oxygen-delivery problem	
symptoms .....	2-31
Oxygen flow problem	
probable causes .....	2-32
Oxygen pressure	
underwater cutting .....	2-6
Oxygen purity	
underwater cutting .....	2-6
Oxygen Regulator Settings for Oxygen-Arc Cutting Electrodes	
Formula .....	2-9
Table 2-2 .....	2-7 thru 2-9
Oxygen Requirements	
at working depth .....	2-6
exothermic electrodes .....	2-22
oxy-arc cutting .....	2-2
per hose length .....	2-7
Parts Information .....	4-27
Parts of a Weld	
Definitions .....	3-10
Polarity .....	4-11
Polarity Test .....	4-11
Poor Visibility	
alternate technique .....	2-14
Poor weld deposits	
indications .....	3-16
Post-dive Maintenance	
SMA Welding .....	3-25
Underwater Cutting Equipment .....	2-17, 2-30
Power Cables .....	4-16, D-6
Power converters .....	4-9
Power Settings for Cable Length/Size	
Ultrathermic electrodes .....	2-22
Power Supply	
DC Welding Generators .....	D-5, 4-16
Power Supply Requirements .....	4-9
Procedure for Repairing Small Cracks .....	3-22
Recommended Amperage Settings	
for wet welding .....	3-7
References .....	C-1

## S0300-BB-MAN-010

Resistance .....	4-13
Safety in Underwater Cutting and Welding .....	D-1
Safety Switches .....	4-16, D-7
knife switch .....	4-16
Scope .....	1-1
Sea-Jet cutting electrode	
design .....	2-22
SEASTUD	
Friction Stud Welder .....	E-26
Self-Consuming Technique .....	3-14
SMA .....	3-13
Self-Consuming and Manipulative Techniques .....	3-20
Shielded Metal Arc .....	4-1, 4-18
Shielded Metal Arc Cutting .....	1-2, 2-1, 2-44 thru 2-46
Shielded Metal Arc Welding .....	3-3
Shipbuilding Materials .....	3-3
Special Electrical Precaution	
using Kerie cable .....	2-43
Steel-Tubular Electrode Cutting Technique	
cast iron and non-ferrous metals .....	2-18
thin plate .....	2-15
Steel-Tubular Electrode .....	2-3
description .....	2-3
Straight polarity .....	2-1
Strength of Underwater Fillet Welds .....	3-10
Surface Cleaning .....	3-12
Surface Welding Electrodes Suitable for Wet Welding .....	E-23
Thermic Lance	
Set Up Procedure .....	E-8
Thermic Lances (Burn Bars) .....	E-5
Tong Test Ammeter .....	2-5, 2-21, 3-6, 4-8, 4-13, 4-28
Torch	
over-bottom pressure .....	2-6
Trial Weld .....	3-12
Trouble Shooting	
oxy-arc cutting system .....	2-31
Ultrasonic thickness .....	4-8, 4-20
Ultrathermic .....	2-2, 2-22, 2-23
Ultrathermic electrode	
design .....	2-22
Underwater Arc Cutting and Welding Equipment	
Diving Equipment .....	4-1
Oxygen-Arc .....	4-1
Shielded Metal Arc .....	4-1

## S0300-BB-MAN-010

Underwater Cutting .....	1-1, 1-2, 2-1, 2-3, 2-6, 2-14, 2-21, 2-25, 2-27, 2-41, 2-43
methods .....	2-1
overview .....	1-1
Underwater Cutting and Welding	
difficulties .....	1-1, 3-8
qualification .....	1-1
Underwater Cutting Torch	
types .....	2-21
Underwater Shielded Metal Arc Welding Techniques .....	3-13
Underwater Shielded Metal Arc Welding Electrodes .....	3-6
Underwater Welding Arcs .....	3-8
Using a Circular Patch .....	3-22
Using a Rectangular Patch .....	3-22
Voltage .....	4-13
Pressure .....	4-13
Waterproof Flux Coating .....	2-2
Waterproofing Surface Electrodes	
for underwater cutting .....	2-44
Waterproofing Surface Electrodes for Underwater Welding .....	E-22
Weld Inspection .....	3-16
Welding Accessories .....	4-20
Magnetic Particle .....	4-20
Tong Test .....	4-20
Ultrasonic Thickness .....	4-20
Welding equipment	
Magnetic Particle test kit .....	4-20
Ultrasonic thickness and flaw detection device .....	4-8
Welding generator .....	4-11, 4-15
Amperage and Voltage Settings .....	4-15
Diesel Driven .....	4-15
Welding on Thin Plates .....	3-20
Welding Setup Procedures .....	3-13
Welding Shields	
MK12, MK1, MOD 0 and Superlite 17B .....	4-1, 4-3 thru 4-8
Wet Welding .....	3-3
advantages .....	3-3
Amperage Settings .....	E-25
definition .....	3-1
Wet welding electrodes	
commercially produced .....	3-6
When cutting is preferred over welding .....	1-1

Ref: NAVSEAINST 4160.1A  
NAVSEA S0005-AA-GYD-030/TMMP

(Insert Classification of TMDER Here) CLASSIFICATION:

**NAVSEA/SPAWAR TECHNICAL MANUAL DEFICIENCY/EVALUATION REPORT (TMDER)****INSTRUCTION: Continue on 8 1/2" x 11" paper if additional space is needed.**

1. USE THIS REPORT TO INDICATE DEFICIENCIES, PROBLEMS, AND RECOMMENDATIONS RELATING TO PUBLICATION.
2. FOR CLASSIFIED TMDERS, FILL IN YOUR ADDRESS IN SPACE PROVIDED ON BACK, FOLD AND TAPE WHERE INDICATED, AND MAIL (SEE OPNAVINST 5510H FOR MAILING CLASSIFIED TMDERS.)

1. PUB NO.	2. VOL/PART	3. REV. NO./DATE OR TM CH. NO./DATE	4. SYSTEM/EQUIPMENT IDENTIFICATION
------------	-------------	--	------------------------------------

5. TITLE	6. REPORT CONTROL NUMBER
----------	--------------------------

**7. RECOMMENDED CHANGES TO PUBLICATION**

PAGE NO. A.	PARA- GRAPH B.	C. RECOMMENDED CHANGES AND REASONS

8. ORIGINATOR'S NAME AND WORK CENTER (Please Print)	9. DATE	10. DSN/COMM NO.	11. TRANSMITTED TO
--	---------	------------------	--------------------

12. SHIP HULL NO. AND/OR STATION ADDRESS (Do Not Abbreviate)

-----  
FOLD HERE

DEPARTMENT OF THE NAVY

**PLACE  
POSTAGE  
HERE**

=====  
Official Business

**COMMANDER  
PORT HUENEME DIVISION CODE 5B00  
NAVAL SURFACE WARFARE CENTER  
4363 MISSILE WAY  
PORT HUENEME, CA 93043-4307**

-----  
FOLD HERE