

REV	A	APPLICATION	
		NEXT ASSY	USED ON
SHT	1		

REVISIONS			
REV	DESCRIPTION	DATE	APPROVED
-	RELEASED AS REVISION -	3/28/08	<i>Robert A Throm</i>
A	UPDATE OF REVISION -	6/12/09	<i>Robert A Throm</i>

NAVSEA DRAWING NO. 8328898
ESWBS 499

This Navy Drawing contains test sample configurations (including the fiber optic components/materials used), test sample fabrication (preparation), launch condition method, specific test practices pertaining to the mechanical splice per MIL-PRF-24623/7. This mechanical splice is used in aircraft applications primarily; however, usage may extend to shipboard and other vehicle type applications.

Intent

1. This Navy Drawing supports the Qualified Products List (QPL) testing for the MIL-PRF-24623/7 for both a temperature range of -40 to 85 °C and a temperature range of -55 to 165 °C.
2. This Navy Drawing supplements MIL-PRF-24623/7.
3. This Navy Drawing minimizes variables in testing by standardizing areas in fabrication and testing. Minimizing test variables permits more accurate comparison of test results from multiple sources of supply when testing is performed by multiple test laboratories. This consistency with test results allows the comparison with Fleet/Field performance, and if needed, the redress of performance requirements or test methodology.
4. The appendices to this Navy Drawing supplements MIL-PRF-24623 by specifying requirements for fixtures and tools required in testing and fabrication.

REV STATUS OF SHEETS	REV SHEET	A	A	-	A	A	A	-	-	-	-	-	-	-	-	-	-	-	-	-	-
		1	2	3	4	5	6	7	8	9	10	11	12	13	14	15	16	17	18	19	20

DISTRIBUTION STATEMENT A: APPROVED FOR PUBLIC RELEASE; DISTRIBUTION IS UNLIMITED.

UNLESS OTHERWISE SPECIFIED DIMENSIONS ARE IN INCHES TOLERANCES ARE:	CAGE CODE CONTRACT NO.			DEPARTMENT OF THE NAVY NAVAL SEA SYSTEMS COMMAND WASHINGTON, D.C. 20362-5101								
	APPROVED	B. McDermott	03/28/08									
FRACTIONS DECIMALS +/- .xx+/- ANGLES .xxx+/- P DO NOT SCALE DRAWING	CHECKED	O. Muja	03/28/08	MECHANICAL SPLICE, FIBER OPTIC, AIRCRAFT, TEST SAMPLE CONFIGURATIONS/FABRICATION & SPECIFIC METHODS/PRACTICES								
	CHECKED	C. Good	03/28/08									
PREPARED	E. Bluebond	03/28/08										
MATERIAL:	ACCEPTED FOR NAVSEA	R. Throm	03/28/08	SIZE	CAGE	ESWBS	DRAWING NO.	REV				
FINISHES:	APPROVED BY NAVSEA			A	53711	499	8328898	A				
				SCALE: NONE UCI		WT GRP		SHEET 1 OF 17				

REV A
SHT 2
NAVSEA DRAWING NO. 8328898
ESWBS 499

Contents

Qualification

Appendices:

- A: Termination for MIL-PRF-24623/7 Mechanical Splices.
- B: Fiber Optic Mechanical Splice Shock and Vibration Test Fixture.

Notes

1. Background.
 - a. Test sample configurations. Dependent upon the inspection/test performed, the mechanical splice test samples shall be in one of three configurations:
 - (1) Un-terminated,
 - (2) As part of a single fiber cable (i.e., a cable assembly),
 - (3) As a cable assembly outside of a cable harness.
 The construction details for each of the three test sample configurations are listed under the section in this drawing for "Qualification".
 - b. Multiple party testing considerations. The incentive to minimize test variables, resulting in a level playing field for multiple parties testing, leads the Government to establish a baseline. This baseline includes considerations for fabrication of test samples, methods to employ launch conditions and use of specific test practices in addition to specifics for test sample configurations.
2. Source to obtain this document. A copy of this document can be obtained at [Web Site: https://fiberoptics.nswc.navy.mil/](https://fiberoptics.nswc.navy.mil/) in the NAVSEA Drawing section under Component Information. If unable to access this Web Site, request an application by e-mail to NSWC DD Warfare Systems Department at DLGR_NSWC_Foweb@navy.mil.
3. Inquiries and clarifications on this NAVSEA Drawing are to be placed in writing and sent by e-mail to DSCC VQP. Current DSCC-VQP point of contact can be obtained at Web Site: <http://www.dsccl.dla.mil/programs/qmlqpl/>. To obtain current technical contact, select Programs/Contacts followed by selecting on Passive Devices Team.
4. Submittal of vendor documentation (termination procedures and test reports). Original and two copies are to be submitted to DSCC VQP.

Qualification.

1. Test sample configuration for MIL-PRF-24623/7 mechanical splice.
 - a. Applicable documentation.
 - (1) Termination procedure. Termination procedure is currently being prepared with the intent to incorporate into Fleet/Field personnel documents. This draft is not complete to the extent that process steps are incomplete or not defined and that strip dimensions, as listed in a table format, require input from each vendor. Vendors shall be required to use this termination procedure, enter the applicable table information and mark up any deviations taken. The marked up draft shall be submitted before test sample fabrication. Government personnel will verify adequacy of the marked up draft submitted as part of the QPL process. Upon verification, the Government will finalize the procedures for incorporation into Government documentation. Draft for this termination procedure is included as appendix A of this drawing for vendor convenience.
 - b. Test samples: Un-terminated termini
 - (1) Quantity: Minimum of 48 mechanical splices for each fiber type (single mode, multimode, multimode 100)
 - (1) Allocation of these 48 mechanical splices for remaining testing is as follows (see table III):
 - (a) Mechanical splice as part of a single fiber cable (16 for type 1 cable, 16 for type 2 cable, 8 for type 3 cable).
 - i Group 2 (Mechanical): 8 for type 1 cable, 8 for type 2 cable, 8 for type 3 cable.
 - ii Group 3 (Environmental): 8 for type 1 cable, 8 for type 2 cable.
 - iii Group 4 (Material): 4 with type 1 cable from Group 1, 4 with type 2 cable from Group 1, 4 with type 1 cable from Group 3, 4 with type 2 cable from Group 3, 4 with type 3 cable from Group 2.
 - (b) Mechanical splice outside a cable harness (4 for type 1 cable, 4 for type 2 cable).
 - i Optical, vibration, shock, optical: 4 with type 1 cable, 4 with type 2 cable.

SIZE A	CAGE 53711	ESWBS 499	DRAWING NO. 8328898	REV A
SCALE: NONE		UCI	WT GRP	SHEET 2 of 17

Table I. Mechanical splice allocation table for each fiber size tested. 1/, 2/

Test Performed	Cable		
	Type 1	Type 2	Type 3
Un-terminated mechanical splice			
Visual inspections	20	20	8
Mechanical splice as part of a single fiber cable assembly			
Group 1 (Optical)	16 of 20	16 of 20	8 of 8
Group 2 (Mechanical)	8 of 16 (from Group 1)	8 of 16 (from Group 1)	8 of 8 (from Group 1)
Group 3 (Environmental)	8 of 16 (from Group 1)	8 of 16 (from Group 1)	---
Group 4 (Material)	4 from Group 2 4 from Group 3	4 from Group 2 4 from Group 3	---
Mechanical splice outside a cable harness			
Optical, vibration, shock	4 of 20	4 of 20	---

- 1/ Fiber size refers to the fiber sizes listed in table II.
- 2/ A minimum of three separate samples (per test) of each polymeric material part that is part of the mechanical splice shall be included for fungus resistance, ozone exposure and fluid immersion.

- c. Test samples: Mechanical splice as part of a single fiber cable and when outside the cable harness
 - (1) Quantity: 48 mechanical splices from the lot of un-terminated mechanical splices
 - (2) Configurations and fabrication. Test sample configurations (single mode, multimode and multimode 100 on each type cable) and fabrication of each cable assembly shall conform as specified in 1.d below.
 - (3) Configurations and fabrication. Test sample configurations and fabrication of mechanical splice cable assembly shall conform as specified below. Other instrumentation-end connectors may be used in lieu of ST connectors. Each cable assembly shall consist of 10 meters of cable with the DUT (i.e., the Device Under Test or mechanical splice) in the middle (at 5 meters) and single ferrule connectors on the ends to mate with the optical instrumentation. Submit request for any alternate cable length proposal to DSCC-VQP. A justification with proposed length deviation and test setup that would allow for successful performance with the proposed deviated length must be included.
 - (4) Configuration allowance for insertion loss measurements. In general, each cable assembly (connector mated pair) shall consist of 10 meters of cable with the DUT in the middle (at 5 meters) and single ferrule connectors on the ends to mate with the optical instrumentation. For insertion loss tests on cable assemblies where a cut-back must be performed, a 13 meter length of cable is required with the DUT placed 8 meters from the launch end of the cable. This allows 3 cut-backs to be performed, each cut-back being one meter long.
 - (5) Cable type. Cable used must be the cable as specified in table II.
 - (6) Test methods and practices. Launch conditions and measurements for the change in optical transmittance shall conform as specified in 3.a below.
- d. Cabling
 - (1) Cable type. The type 1, type 2 and type 3 cable used is listed in table II.

Table II. Cable for each fiber type.

Fiber Size	Type 1 Cable	Type 2 Cable	Type 3 Cable
Single Mode	5/125 micron: OFS part # C10026 or BC06814 1/	<i>This test configuration is not required</i>	9/125 micron: MIL-PRF-85045 PIN M85045/16-02 2/
Multimode	50/125 micron: OFS part # C10027 or BC06815	62.5/125/155 micron: General Cable part # OC-1660	62.5/125 micron: MIL-PRF-85045 PIN M85045/16-01
Multimode 100	100/140/172 micron: OFS part # BC05082	100/140/172 micron: General Cable part # OC-1260	<i>This test configuration is not required</i>

- 1/ Fiber size: 5/ 125 micron = 5.1/125 micron at 1310 nm, 5.8/125 micron at 1550 nm
- 2/ Fiber size: 9/ 125 micron = 8.5-10/125 micron

- 2. Other fabrication and test sample assembly requirements.
 - a. Epoxy cure schedule.
 - (1) Epo-tek 353ND shall be used when the mechanical splice uses a two-part epoxy. The cure schedule shall be as follows:
 - (a) Ramp: From ambient to 80 C in 5 minutes
 - (b) Soak: 80 C for 10 minutes
 - (c) Ramp: 105 C for 5 minutes

REV A
 SHT 4
 NAVSEA DRAWING NO. 8328898
 ESWBS 499

- (d) Soak: 105 C for 5 minutes
- (e) Ramp: 120 C for 5 minutes
- (f) Soak: 120 C for 5 minutes
- (g) Ramp: 150 C for 5 minutes
- (h) Soak: 150 C for 5 minutes
- (i) Ramp: Turn heat off and let sit in oven for 15 minutes before removal

3. Test methods and practices.

a. Launch conditions.

- (1) Fiber size 5/125 micron. A mandrel diameter shall be used as the means of mode conditioning to filter out higher order modes. The technique of wrapping the fiber around a mandrel shall be performed as specified see 3.5 of TIA/EIA-455-34. A diameter of 60 mm shall be used with 1 complete turn of the fiber wrapped around the mandrel.
- (2) Fiber size 9/125 micron. A mandrel diameter shall be used as the means of mode conditioning to filter out higher order modes. The technique of wrapping the fiber around a mandrel shall be performed as specified see 3.5 of TIA/EIA-455-34. A diameter of 30 mm shall be used with 3 complete turns of the fiber wrapped around the mandrel.
- (3) Fiber size 50/125 micron. A 2 meter length of OFS optical fiber BF06819 or OFS fiber optic cable C16133 is to be used as the launch condition cable.

Note: Policy for Government provisioning of launch conditioning cable.

Eligible parties. The Government, at their discretion, may provide the test laboratory or vendor doing the testing (the recipient) with 70 meter spool of the required launch condition cable (sufficient length of OFS C16133 fiber optic cable to terminate connectors on the ends of 32 two meter lengths of launch conditioning jumpers). Only recipients doing the testing are to receive cable. Only one provision (70 meter spool) of cable will be provided even if the recipient is testing multiple vendors.

Intended use. Sole use of cable provisioned shall be for QPL testing. Cable shall not be used to fabricate MQJ (Measurement Quality Jumper) cables or other type cables.

Recipient responsibilities. The recipient shall make the connector terminations and retain the terminated cable for future use. Recipients that do not complete the QPL process shall return the cable. Unused lengths shall be returned to the Government. The recipient shall bare shipping costs.

Method to request launch condition cable. Requests for launch condition cable shall be made to DSCC-VQP Qualifications Group. Requests are to be submitted via e-mail and include the following information: Recipient (company) name, shipping address, point of contact with telephone number and e-mail address, DSCC test report number located on Form 19P, recipient's express mail shipping company, recipient's account number for the express mail shipping company.

- (4) Fiber size 62.5/125 micron. For 62.5/125 micron optical fiber, use a 2 meter minimum length of 50/125 micron optical fiber with a 0.2 NA.
- (5) Fiber size 100/140 micron. ASA 100 restricted launch condition shall be used as the means to provide a restricted launch.

Note: Government to provide details on standard method to implement this launch condition at a later date.

b. Specific test practices. Testing shall be performed as specified in MIL-PRF-24623/7 using cited test standards (such as TIA/EIA). Specific test practices for the optical performance tests, including clarifications and further details, are found in the Optical Test Measurement Guide. A copy of this document can be obtained at [Web Site: https://fiberoptics.nswc.navy.mil/](https://fiberoptics.nswc.navy.mil/) in the Policy and Guidance section under Testing Information. If unable to access this Web Site, request an application by e-mail to NSWC DD Warfare Systems Department at DLGR_NSWC_Foweb@navy.mil.

- (1) Shock test. Standard shock fixture 4A for bulkhead mounting shall be used. Supplement test fixture that shall be used and the mounting shall be performed as specified in Mechanical Shock (Hi-Impact) Test and Measurement Guide letter. A copy of this document can be obtained at [Web Site: https://fiberoptics.nswc.navy.mil/](https://fiberoptics.nswc.navy.mil/) in the Policy and Guidance section under Testing Information. If unable to access this Web Site, request an application by e-mail to NSWC DD Warfare Systems Department at DLGR_NSWC_Foweb@navy.mil.

SIZE A	CAGE 53711	ESWBS 499	DRAWING NO. 8328898	REV A
SCALE: NONE		UCI	WT GRP	SHEET 4 of 17

REV A
SHT 5
NAVSEA DRAWING NO. 8328898
ESWBS 499

This draft dated 07 September 2007 is to be used for termination or repair of a fiber optic cable by insertion of the M24623/7 fiber optic mechanical splice into a damaged section of fiber optic cable. This draft is intended to be used as a template and revised to accommodate each specific mechanical splice. Generic figures (black & white drawings) illustrating common operations and figures showing vendor specific operations are requested. Recommendations for any revisions are welcome and are to be submitted for approval.

Appendix A

Termination for M24623/7 Mechanical Splices

MECHANICAL SPLICE INSTALLATION

1. SCOPE.

1.1 Scope. This method describes a procedure for installing a MIL-S-24623/7 mechanical splice onto a single fiber cable. Mechanical splice end preparation sequencing/flow starts with the cable end in the harness assembly. Once that ends meets the tailored mechanical requirements the 18 inch terminus ended cable end will be prepared. Each layer of the cable assembly will be stripped, cut or cleaved to there appropriate dimensions in order to receive the mechanical splice.

2. REQUIRED EQUIPMENT AND MATERIALS.

2.1 The equipment and materials in table I shall be used to perform this procedure:

TABLE I. Equipment and materials.

Item	Description	Quantity	Cage Code	Part or Identifying No.
Termination Tools & Accessories				
Cutting and Stripping				
101	Marker, permanent, ink	1	TBD	TBD
102	Strip tool, buffer (micro strip), commercial & M85045/16 fiber, w/ red blades NSN 5110-01-419-4361	1	08RC6	0700-3070
102A	Blades, aircraft fiber, strip tool, buffer (micro strip), light blue blades	1	59984	MS1-RB-10S
103	Alternate strip tool, buffer (no nicks), commercial & M85045/16 fiber, red handle	1	71827	NN203
103A	Alternate strip tool, buffer (no nicks), aircraft fiber, blue handle	1	71827	NN254
104	Strip tool, OFCC, AWG 18, commercial & M85045/16 Cable	1	75347	11045
			64959	104 278 478
104A	Strip tool, OFCC, aircraft tight buffered cable	1	30119	45-162
104B	Strip tool, OFCC, aircraft loose tube cable	1	30119	45-163
105	Shears, Aramid yarn (Kevlar) NSN 5110-01-419-5283	1	71827	86 1 /2S
			OKN34	744
109A	Template, cut length, MIL-PRF-24623/7 mechanical splice (Vendor unique)	1	TBD	TBD
110	Ruler, Machinist NSN 5200-00-725-7347	1	81348	GGG-R-79
			32445	SS-6
111	Cleaning wire, 125 um, w/ container (3 pieces min) NSN 9505-01-376-9398	1	08RC6	0700-3210
112	Pick, for separating braided aramid yarn (fiber glass)	1		
Cleaving				
146	Cleaver (tip shaper -BGMcD), fiber optic, 3 degree cleave angle	1	TBD	TBD
147	Debris bottle, flip-top, for cleaved fiber ends	1	08RC6	0700-9975

SIZE A	CAGE 53711	ESWBS 499	DRAWING NO. 8328898	REV A
SCALE: NONE UCI		WT GRP	SHEET 5 of 17	

Item	Description	Quantity	Cage Code	Part or Identifying No.
Cable alignment & crimping				
121	Assembly tool, mechanical splice alignment	1	TBD	TBD
122	Tape, vinyl	1	TBD	TBD
123	Crimp tool, for crimp sleeve, M24623/7	1	TBD	TBD
124	UV blocking shield	1	TBD	TBD
Curing				
143	Curing oven, UV light source, M24623/7	12	TBD	TBD
144	Safety glasses, UV absorbing	1	TBD	TBD
Heat shrinking				
161	Heat shrink gun	1	TBD	TBD
Connector assembly				
171	Screwdriver, reversible	1	08RC6	4300-9000
Miscellaneous				
190	Flashlight	1	62576	230
			7J761	1900C
191	Foreign Object Debris (FOD) pouch	6	08RC6	0400-3020
192	Tweezers	1	08RC6	0700-8911
193	Eye Loupe, 7X min for viewing ferrule end face polish NSN 6650 00 994 6883	1	06175	654 2039
			4M564	ELP-174 10X
Safety				
001	Safety glasses NSN 6540-01-433-7953	1	75347	60050
			7J61	TK110
002	Tweezers, Teflon coated NSN 6635-01-232-9536	1	32218	GTP-293
			7J761	6005268
003	Mat, black, non-reflective work surface, 12"x18" min.	1	71827	FS100
Miscellaneous				
Cleaning supplies: See note below table.				
	Termini pigtail (pin or socket terminus on 18" cable)	1	TBD	TBD
Safety				
A001	Gloves,examining,nitrile,powder-free,6 mil thick,100/bx	1	59728	5761R08

1/ Cleaning consumable supplies only. Cleaning supplies are listed under Manual Cleaning Procedures in NAVAIR 01-1A-505-4/T.O. 1A-01-14-4 (see WP 008 02).

CAUTION: Throughout the termination process, cleanliness is critical to obtaining a high optical quality mechanical splice. Make sure that your hands and the work area are as clean as possible to minimize the ingress of dirt into the mechanical splice.

NOTE: Verify that the adhesive and index matching material shelf life has not expired. Do not use adhesive or index matching material with an expiration date that has passed.

3. PROCEDURE.

3.1 Safety summary. The following safety precautions shall be observed:

- a. Safety glasses shall be worn at all times when handling bare fibers or dispensing adhesive.
- b. Do not touch the ends of the fiber as they may be razor sharp. Wash your hands after handling bare fiber.
- c. Avoid skin contact with adhesives.

SIZE A	CAGE 53711	ESWBS 499	DRAWING NO. 8328898	REV A
SCALE: NONE		UCI	WT GRP	SHEET 6 of 17

REV -
SHT 7
NAVSEA DRAWING NO. 8328898
ESWBS 499

- d. Do not stare into the end of a fiber until verifying that the fiber is not connected to a laser light source or LED.
- e. Ultraviolet (UV) safety glasses shall be worn when using the UV curing lamp.

3.2 Procedure.

3.2.1 Pre-installation preparation, connector end.

- Step 1 - Remove faulty fiber optic terminus (such as MIL-STD-29504/4 or /5 terminus) from connector (i.e., a multiple terminus connector such as a MIL-DTL-38999).
- Step 2 - Annotate the cavity from which you removed the terminus.
- Step 3 - Insert the pre-terminated replacement cable pigtail (i.e., the terminus pigtail) into the slot vacated by the faulty terminus.
- Step 4 - Measure enough cable slack from the terminus pigtail connector, so that the pigtailed cable end over laps at least 2 1/2 – 3 inches of the harness cable end.
- Step 5 - Mark and the cut the terminus pigtail cable at your marking.
- Step 6 - Remove the cut terminus pigtail from the MIL-STD-38999 connector before continuing.
- Step 7 - Place a dust covers on the connector (such as a MIL-DTL-38999) front face.
- Step 8 - Dispose of fiber and cable harness debris.

3.2.2 Pre-installation preparation, cable harness end.

- Step 1 - Remove cable remnant from cable harness.
- Step 2 - Cut back the cable end in the cable harness a minimum of 8 inches to allow for cable restoration by installing a mechanical splice.
- Step 3 - Dispose of fiber and cable harness debris.

3.2.3 Cable and fiber preparation.

NOTE: Setup you work area. Make sure the working surface is clean, level and has access to power. Place your tool and consumables in easily accessible reach.

- Step 1 - As applicable, slip the heat shrink tubing with the fiber identification over the simplex cable (single fiber cable).
- Step 2 - Feed the simplex cable (single fiber cable) into the supplied heat shrink that is packaged with the mechanical splice. Next slide both the identification heat shrink and the mechanical splice heat shrink back from the end of the simplex cable.

NOTE: Only use the heat shrink that is supplied with the mechanical splice.

NOTE: Keep the cables and mechanical splice parts free from oil, dirt and grease throughout the installation procedure. If cleaning is necessary, use a wipe dampened with alcohol, then blow the part dry with air.

NOTE: If braided fiber glass, and not Kevlar (aramid yarn) is used in the cable as the strain relief, then the fiber glass must be “combed” straight from a braid prior to trimming. This combing is done using pick or other pointed edge tool (such as a tweezers).

- Step 3 – Mark the simplex cable outer jackets to dimension A and to dimension B in table II (see figure 1).
- Step 4 - Remove the simplex cable jackets back to dimension B in table II using the simplex cable stripper and trim the Kevlar (aramid yarn) using the Kevlar shears so that it is even with the simplex cable jacket.

NOTE: The optimum way to remove the simplex cable jackets is to ring cut the jacket with the simplex cable stripper and pull the jacket off by hand. Pushing off the simplex cable jacket with a tightly held simplex cable stripper can lead to fiber breakage.

SIZE A	CAGE 53711	ESWBS 499	DRAWING NO. 8328898	REV -
SCALE: NONE		UCI	WT GRP	SHEET 7 of 17

TABLE II. Cable stripping dimensions.

Vendors	Strip Dimensions mm (in) <u>1/</u> , <u>2/</u>		
	A	B	C
	???	???	???
	(?.?)	(?.?)	(?.?)

1/ Tolerances on all dimensions are ± 1.6 mm (0.06 in).
2/ Vendors are requested to provide their strip dimensions either to the nearest 1 mm or to the nearest 1/16 inch for ease of user measurement.

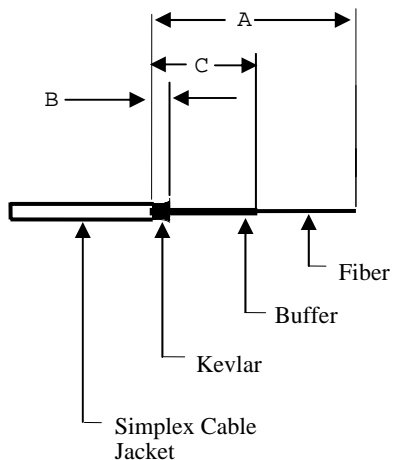

Figure 1. Cable stripping dimensions.

Step 5 - Next remove the simplex cable jackets back to dimension A in table II using the simplex cable stripper. This step will expose the Kevlar to the appropriate length.

Step 6 - **WARNING:** Wear safety glasses when removing the fiber buffer and coating to avoid possible eye injury.

Remove the fiber buffers and coatings back to dimension C in table II using the buffer stripper. Remove the buffer and coating in small sections (approximately 6 mm (0.25 in) at a time.)

NOTE: Normally, the buffer and coating are tightly adhered to one another and come off of the fiber at the same time.

NOTE: Some aerospace cables have a silicone buffer which can be remove in one section, using the buffer stripper, instead of having to be removed in 6 mm (0.25 in) increments.

NOTE: Polyimide coatings are not to be removed.

Step 7 - **CAUTION:** The uncoated/bare (or polyimide coated) fiber is in its most vulnerable state. Take extreme care not to damage the fiber. Breakage of any one fiber from this point until the connector is completely assembled will require repetition of this and the following steps in order to maintain approximately equal length of all the fibers in the cable.

Remove any residual coating material from the bare fibers with a wipe dampened with alcohol. Wipe only once from the end of the buffer towards the end of the fiber.

NOTE: Do not repeatedly wipe the bare fiber, as this will weaken the fiber.

NOTE: Do not dampen the Kevlar strength member while cleaning the fiber. Alcohol will contaminate the epoxy and compromise the bond of the strength member to the terminus.

NOTE: Recommended time that the bare fiber be exposed to the environment before installation into the mechanical splice is 60 minutes or less.

3.2.4 Cleave the ends of the fiber on each cable end.

- Step 1 - Set the cleaver for the cleaved bare fiber length in table III for the particular vendor mechanical splice being installed.
- Step 2 - Open the cleaver clamps.
- Step 3 - Insert the stripped portion of the fiber into the cleaver, bare fiber end first
- Step 4 - Continue to feed the stripped fiber into the cleaver until the start of the buffered fiber contacts a mechanical stop.
- Step 5 - Verify that the stripped fiber is seated properly on the cleaver table/optical fiber support channel.
- Step 6 - Tension the fiber by closing the cleaver clamp at the bare optical fiber end.
- Step 7 - Close the other cleaver clamps, verifying that the stripped fiber is in tension and seated properly.
- Step 8 - Depress the cleaving mechanism to cleave the stripped fiber to the specified length for the mechanical splice being installed (see table III).
- Step 9 - If the stripped fiber is cleaved, then proceed to step 12; otherwise, re-depress the cleaving mechanism.
- Step 10 - If the stripped fiber is cleaved, then proceed to step 12; otherwise, remove the stripped fiber from the cleaver and redo steps 1 through 7.
- Step 11 - If the stripped fiber is cleaved, then proceed to step 12; otherwise, remove the stripped fiber from the cleaver and replace the cleaver.
- Step 12 - Remove and dispose the remnant piece of cleaved optical fiber.
- Step 13 - Open the cleaver clamps and remove the stripped fiber with the cleaved fiber end.
- Step 14 - Measure the cleaved bare fiber length and verify the distance from the fiber end to the start of the buffer is the length listed for the mechanical splice in table III.
- Step 15 - If the proper length is measured, then proceed to step 16; otherwise, redo steps 1 through 14.

NOTE: Redo steps 1 through 14 if the fiber length exceeds the specified cleaved bare fiber length, fractures or breaks. Breaks include bare fiber lengths shorter or longer than those listed.

Step 16 - **CAUTION:** The uncoated/bare (or polyimide coated) fiber is in its most vulnerable state. Take extreme care not to damage the fiber. Breakage of any one fiber from this point until the connector is completely assembled will require repetition of this and the following steps in order to maintain approximately equal length of all the fibers in the cable.

Clean the bare fiber length with a wipe dampened with alcohol. Wipe only once from the end of the buffer towards the end of the fiber.

NOTE: Do not repeatedly wipe the bare fiber, as this will weaken the fiber.

NOTE: Do not dampen the Kevlar strength member while cleaning the fiber. Alcohol will contaminate the epoxy and compromise the bond of the strength member to the terminus.

NOTE: Recommended time that the bare fiber be exposed to the environment before installation into the mechanical splice is 60 minutes or less.

SIZE A	CAGE 53711	ESWBS 499	DRAWING NO. 8328898	REV -
SCALE: NONE UCI		WT GRP	SHEET 9 of 17	

TABLE III. Cleaved bare fiber insertion length and UV adhesive cure setting.

Vendor	Cleaved bare fiber length mm (in) <u>1/</u> , <u>2/</u>	Total UV Intensity Dose Joules/sq-cm
	???	<u>3/</u>
	(?.?)	

- 1/ Tolerances on all dimensions are ± 1.0 mm (0.04 in).
- 2/ Mechanical splice to comply with the cleaver compatibility requirement. The mechanical splice shall be able to accept one of the following cleaved bare fiber insertion lengths: 5, 10, 15 or 20 mm.
- 3/ Range of settable total UV dose shall be from 0.1 Joules/sq-cm to 10.0 Joules/sq-cm in increments of 0.1 Joules/sq-cm. Value vendor places in table is to be within this range.

3.2.5 Insert stripped fibers into mechanical splice.

- Step 1 - Place the mechanical splice assembly tool onto the work surface and orient in proper position for use.
- Step 2 - Open the locking mechanism.
- Step 3 - Remove dust covers/bonding agent plugs from the mechanical splice.
- Step 4 - Remove cable strain relief capture parts from the mechanical splice.
- Step 5 - Insert the mechanical splice into the assembly tool channel until a mechanical stop is reached. Lock mechanical splice in-place.
- Step 6 - Cover the entire mechanical splice with a UV blocking shield if the curing process will be performed in direct or bright sunlight or under bright fluorescent lamps
- NOTE: Normal ship lighting is not bright enough to cause the UV adhesive to cure prematurely.
- Step 7 - Place the cable strain relief capture parts from the mechanical splice onto each end of the stripped fiber.
- Step 8 - Carefully pick up the cable harness stripped fiber end by its coating and outer jacket.
- Step 9 - Insert the bare fiber end into the mechanical splice cavity. Feed the fiber into the cavity. If you feel resistance when sliding the fiber, try rotating while sliding.
- Step 10 - Continue to feed the bare fiber then the fiber buffer fully into the cavity. All that should be visible is the fiber jacket and strength member.
- Step 11 - Carefully pick up the pre-terminated replacement cable pigtail (i.e., the terminus pigtail) by its coating and outer jacket.
- Step 12 - Insert the bare fiber end into the mechanical splice cavity. Feed the fiber into the cavity. If you feel resistance when sliding the fiber, try rotating while sliding.
- Step 13 - Continue to feed the bare fiber then the fiber buffer fully into the cavity. All that should be visible is the fiber jacket and strength member.
- Step 14 - Push the cable on the cable harness end (i.e., first cable inserted into the mechanical splice) towards the terminus pigtail (i.e., second cable inserted into the mechanical splice) while holding or ensuring that the second cable is taught.
- Step 15 - Stop pushing the cable on the cable harness end once there are equal bends in both cables.

NOTE: Both cables should deflect about 10 to 13 mm (3/8 to 1/2 inch) at the maximum deflection (middle of the bent cable portion) from the taught position.

3.2.6 Curing the bonding agent.

- Step 1 - Remove the UV blocking shield, if it was used.
- Step 2 - Set the UV curing lamp to the specified value for the mechanical splice per table III.
- Step 3 - Place the UV curing lamp into the correct position on the assembly tool.
- Step 4 - Do not allow the mechanical splice to slide relative to either cable.

NOTE: If possible, tape the cables to any available surface during the curing period to avoid accidentally pulling the cables out of the mechanical splice out from under the curing lamp.

- Step 5 - WARNING: Wear UV safety glasses when using the curing lamp to avoid possible eye injury.

Turn on the curing lamp and cure the UV adhesive within the mechanical splice.

- Step 6 - Verify that the curing lamp has turned off. Remove the curing lamp from the assembly tool.
- Step 7 - Unlock the assembly tool locking mechanism and remove the mechanical splice from the assembly tool.

NOTE: Handling of the splice - Do not pull, jerk or twist fiber optic cable ends once the splice installation is completed.

3.2.7 Crimping.

- Step 1 - Slide the cable strain relief capture parts from the mechanical splice, now on the cable, onto the mechanical splice.
- Step 2 - Use the crimp tool to crimp the aramid yarn or fiber glass strength member in-place.
- Step 3 - Repeat for other cable inserted into the mechanical splice.

3.2.8 Heat shrink.

- Step 1 - Slide the 3 inch piece of heat shrink sleeving from the cable and center on the mechanical splice.
- Step 2 - Caution: Handle the heat gun with care once turned on. The tip gets very hot and can cause a burn to any skin in which the tip makes contact.
Turn on the heat gun.
- Step 3 - Apply the heated air to the heat shrink in a back and forth motion until the heat shrink reduces in size and tightly straddle the cable jacket and mechanical splice barrel.
NOTE: Do not let the heat gun remain in one position while applying heated air to the mechanical splice.
- Step 4 - Turn off the heat gun and rest it in a safe place (such as back in its cradle).
- Step 5 - Allow the heat shrink to cool for 2 to 3 minutes before proceeding to 3.2.8.

3.2.9 Reassemble connector.

- Step 1 - Insert the terminus back into the connector insert cavity vacated when the cable was cut and the cable remnant (with the terminus on the end) was removed..
- Step 2 - Rebuild the connector/backshell portion of the cable harness.

3.2.10 Quality check.

- Step 1 - Once the ends are mechanical splice are placed onto the fiber optic cabling, the cable harness shall be tested for optical loss compliance (less than 4.6 dB across a link; or 2.5 dB across a cable segment) in accordance with NAVAIR 01-1A-505-4/T.O. 01-1A-14-4 Work Package 009 01 (Optical Loss Measurement, Two Jumper Method).
- Step 2 - Determine if the value obtained for the optical loss is acceptable. If acceptable, proceed to step 10. Otherwise, proceed to step 3.
- Step 3 - If the optical loss exceeds the specified (maximum) value, a second optical loss measurement shall be performed. If the second optical loss measurement is acceptable, proceed to step 10. Otherwise, proceed to step 4.

SIZE A	CAGE 53711	ESWBS 499	DRAWING NO. 8328898	REV -
SCALE: NONE		UCI	WT GRP	SHEET 11 of 17

ESWBS 499
NAVSEA DRAWING NO. 8328898
SHT 12
REV -

- Step 4 - If a second optical loss measurement is not acceptable, the mechanical splice shall be removed (cut out). A second mechanical splice shall be placed onto the same cabling and the quality check in steps 1 through 3 performed. If the second optical loss measurement is acceptable, proceed to step 10. Otherwise, proceed to step 5.
- Step 5 - If the second optical loss measurement for the second installed mechanical splice is not acceptable, the whole cable harness shall be replaced and sent in for "I" level repair.
- Step 6 - Once the cable harness link with the mechanical splice has met the optical loss requirements, the connector backshell portion of the cable harness shall be rebuilt and restored.

SIZE	CAGE	ESWBS	DRAWING NO.	REV
A	53711	499	8328898	-
SCALE: NONE		UCI	WT GRP	SHEET 12 of 17

REV -
SHT 13
NAVSEA DRAWING NO. 8328898
ESWBS 499

Appendix B

Fiber Optic Mechanical Splice Shock and Vibration Test Fixture

Released: 28 March 2008

1. Intent. The purpose of this document is to specify the test fixture, test setup and specific installation requirements for performing shock and vibration testing on a fiber optic mechanical splice. This mechanical splice is used in aircraft applications primarily; however, usage may extend to shipboard and other vehicle type applications.
2. Reference documentation.
 - a. MIL-S-901: Shock Tests, H.I. (High Impact) Shipboard Machinery, Equipment, and Systems, Requirements For
 - b. A-A-52083 Commercial Item Description, Tape, Lacing and Tying, Glass
 - c. NAVAIR 01-1A-505-1/T.O. 1-1A-14: Technical Manual, Installation and Repair Practices, Aircraft Electric and Electronic Wiring
 - d. SAE AS21919 Society of Automotive Engineers Aerospace Standard, Clamp, Loop Type, Cushioned, Support-FSC 5340
 - e. SAE AS 50881: Society of Automotive Engineers Aerospace Standard, Wiring Aerospace Vehicle
3. Definitions.
 - a. Moderate force. The qualitative range of a force than can be applied that falls between a light force and a heavy force. A light force is one in which is limited to the weight of the hand. A heavy force is one that requires physical exertion to the extent that muscle contraction is noticeable or other muscles, outside the hand and wrist, are used to augment in applying the force. While applying a moderate force to test cable deflection, one would observe none to slight flexing of the fingers. No contraction or use of muscles, outside of the hand or wrist, is used to assist in applying the force.
 - b. Primary supports. Supports that carry the weight of and secure the fiber optic cable in its intended position by the use of metal cushion clamps in accordance with AS21919.
 - c. Secondary supports. Supports used to secure the cabling between primary supports and assist in carrying the weight. Lacing tape is used to provide the secondary support. Specifically for this application, the secondary support is the means used to secure the test sample to the test fixture.
4. Test fixture construction.
 - a. Components comprising test fixture. The test fixture shall consist of square stock, primary supports, secondary supports, cabling (simulated by the convoluted tubing portion of a cable harness) used between primary supports, a backing plate (if required) and the DUT (Device Under Test). The primary supports, secondary supports and cabling (simulated by the convoluted tubing portion of a cable harness) used between primary supports shall be affixed to the square stock as shown in figure 1. The square stock shall have a 4 x 4 inch cross section, approximately 0.5 inch thick, 20 inch length and be made of aluminum. If required for vibration testing, a backing plate may be used as an adapter to affix the square stock to the vibration table. The term "backing plate" is meant to include any additional structural member(s) for securing the square stock to the table on the vibration machine or drop tester. The configuration is not limited to a plate or specific location. Backing plate design must be approved by the Qualifying Activity.
 - b. Primary supports.
 - (1) Background. Primary support of fiber optic cable assemblies shall be provided by the use of metal cushion clamps in accordance with AS21919. Plastic cable clamps, lacing tape or plastic cable straps shall not be used for the primary support of fiber optic cable assemblies. Fiber optic cabling includes fiber optic cable, cable bundles, cable harnesses, conduit and convoluted tubing. Secondary supports, as shown in figure 1, are the means used to secure the mechanical splice to a fiber optic cable assembly. Secondary supports will be addressed separately.
 - (a) Size for 0.5 inch diameter convoluted tubing: MS21919WDG10 (NSN: 5340-00-584-6556).
 - (b) Size for 1.0 inch diameter convoluted tubing: MS21919WDG20 (NSN: 5340-00-664-8188).
 Note: These two part numbers may begin in AS21919 instead of MS21919.
 - (2) Distance between clamps. Most cabling damage requiring the use of a mechanical splice is expected to occur near the connector. Two installation configurations for mechanical splice are to be tested to simulate cabling runs from an electronic box that contains a mechanical splice. Test fixture shall simulate these following two installation configurations:
 - (a) Configuration 1. This configuration simulates the installation of a mechanical splice in an 18 inch unsupported run from electronics box. Mechanical splice shall be placed in the middle of the 18 inch run (see configuration (1) in figure 2).

SIZE A	CAGE 53711	ESWBS 499	DRAWING NO. 8328898	REV -
SCALE: NONE		UCI	WT GRP	SHEET 13 of 17

- (b) Configuration 2. This configuration simulates the installation of a mechanical splice at a primary support. Mechanical splice shall be at, and inside, of a primary support. The two adjacent primary supports shall be located 9 inches from the one at the mechanical splice (see configuration (2) in figure 2).
- (3) Number of splices tested. At a minimum, two mechanical splices affixed to a simulated cable harness per test configuration (1) in figure 2 and two mechanical splices affixed to a simulated cable harness per test configuration (2) in figure 2 shall be tested for each type cable and fiber size specified.
- (4) Installation. Open the cable clamp and lay the portion of the fiber optic cabling attached to the mechanical splice into the cable clamp. Do not push the cabling through the cable clamp.
- (5) Tightening. Clamp shall be installed such that they do not exert more pressure on the cable than the minimum required to prevent slipping. Tighten cable clamp to constrain, but not constrict, the cabling (i.e., cabling is snug, but no deformation, kink or pinch is evident).
- (6) Testing. Verify that cabling is installed properly in the cable clamp by performing the following inspections:
 - (1) Sliding (shear or parallel) force. Test by verifying that no sliding is evident when a moderate force is applied.
 - (2) Bending (downward or perpendicular) force. Test by applying a downward force with moderate hand pressure (force) midway between primary supports. Verify that the maximum slack (deflection) midway between primary supports does not exceed 1/2 inch (see figure 3).
- c. Secondary supports.
 - (1) Background. Secondary support of fiber optic cable assemblies shall be provided by the use lacing tape (also referred to as tying tapes, lacing ties or ties) in accordance with A-A-52083, glass tying, sizes 2 or 3, finish C. Continuous lacing, plastic cable clamps or plastic cable straps shall not be used for the secondary support of fiber optic cable assemblies. Lacing tape is the means used to secure the mechanical splice to the test fixture in its intended position and carries its weight. As such, the lacing tape is considered as the secondary support. The term "spot ties" becomes appropriate when lacing tape is used to separate a number of fiber optic cables or cable bundles within a cable harness or convoluted tubing (i.e., as a separator and not a means to secure).
 - (2) Distance between lacing tape (secondary support).
 - (a) At the mechanical splice. One lacing tie shall be placed 0.5 inch from the middle of the mechanical splice along the longitudinal axis (i.e., z axis). A second lacing tie shall be placed 0.5 inch from the middle of the mechanical splice from the other end (see figure 1). If the middle of the mechanical splice is affixed to a cable clamp as done for Configuration (2), then place the lacing ties on the mechanical splice prior to fastening the cable clamp (primary support).
 - (b) On the cabling exiting the mechanical splice. After the initial lacing tie is placed on the mechanical splice, the spacing between adjacent lacing ties on the simulated cable harness (convoluted tubing) shall be every 3 inches (see figure 1).
 - (3) Lacing procedure. Lace or tie mechanical splice and exiting cable securely enough to support these components between the primary supports. Extreme care should be used in lacing to assure that each lacing tie does not deform the exiting cable.
 - (a) First make a clove hitch (see figure 4).
 - (b) Next follow the clove hitch with a square knot. Complete the second part of the square knot with an extra loop as shown in figure 4.
 - (c) Trim the free ends of the lacing ties to 3/8 inch minimum.
- d. Cabling type used between primary supports. The cabling used to represent the outside of a protected cable harness shall consist of the following convoluted tubing:
 - (1) Configure (1). This configuration has 18 inch spacing between primary supports. The mechanical splice is located midway between these two primary supports and is held in-place only by secondary supports. Convoluted tubing used shall be made from FEP (fluorinated ethylene propylene), have a 1.0 inch diameter and conform to Glenair Part # 120-100-1-1-32CF or equivalent.
 - (2) Configure (1). This configuration has 9 inch spacing between primary supports. The mechanical splice is located at and centered in the middle primary support. The mechanical splice is held in-place by midway by the primary support and along the length by secondary supports. Convoluted tubing used shall be made from PEEK (polyether-ether-ketone), have a 0.5 inch diameter and conform to Glenair Part # 120-100-1-1-16CK or equivalent.
- e. Backing plate.
 - (1) MIL-S-901 LWSM (Light Weight Shock Machine). The square stock shall be affixed directly to a type "4A" mounting fixture without a backing plate.
 - (2) Vibration and sinusoidal shock pulse. The backing plate shall contain the applicable hole pattern and be affixed directly to both the square stock and to the vibration machine table.
 - (3) Backing plate material and configuration.
 - (a) Material: Aluminum 6061-T6.
 - (b) Dimensions (as applicable).
 - (c) Thickness: 2 inch (recommended).
- f. Hardware. Screws, spacers and other hardware to secure the primary support (cable clamps) to the 4 x 4 inch square stock are listed in table I.

SIZE A	CAGE 53711	ESWBS 499	DRAWING NO. 8328898	REV -
SCALE: NONE		UCI	WT GRP	SHEET 14 of 17

Table I. Hardware to secure primary supports.

Description	Part Number	NSN
Screw, hex-head, 1" by 10/32"	NAS1096-3-16	5305-01-135-7079
Spacer, 5/8"	NAS43DD3-40	5365-00-808-2527
Washer, flat, 10/32"	AN960C10L	5310-00-167-0812
Nut, self-locking, 10/32" 1/	BRH10A3	5310-00-680-4892

1/ Tapped holes with helical inserts in the 4 x 4 inch square stock and use of a locking compound is a permissible alternative to use of the self-locking nuts.

5. Supplementary requirements.

- a. Accelerometer placement. At a minimum, one accelerometer shall be used to record time history plot (amplitude trace) during shock. Accelerometer shall be mounted on the backing plate adjacent to the leftmost primary support for configuration (1) per figure 2.
- b. Test fixture configuration. The same test fixture with the same configuration shall be used for both shock and vibration testing.

6. Application notes.

- a. Clamp used at primary supports. AS21919 cable clamps are being specified as part of the test fixture since these are the types of clamps used in-service.
- b. Distance between secondary supports. SAE AS 50881 does not specify any distance between secondary supports. NAVAIR 01-1A-505-1/T.O. 1-1A-14 WP 010 00 paragraph 65 states where supports are more than 12 inches apart, space ties 12 inches or less apart. Distance between secondary supports is 3 inches for cabling installed in flight-testing applications.
- c. Test fixture configuration. The same test fixture, excluding backing plate, is used for both shock and vibration testing for test consistency.
- d. Cabling selection.
 - (1) Mechanical splice clamped at primary support. Increased stiffness results in maximum transmission of the input, including those at the higher frequencies. Stiffer material and smaller diameter convoluted tubing is used to simulate the cable harness to enhance this stiffness condition.
 - (2) Mechanical splice between primary supports. Decreased stiffness results in greater deflection and transmission of the input mostly at the lower frequencies. A section of more flexible material and larger diameter convoluted tubing is used to simulate the cable harness to enhance this stiffness condition.
- e. Type of cable harness selected. Open cable bundle selected to verify that mechanical splice does not damage (cut into) the electrical cable insulation during shock and vibration events.
- f. Use of standoffs or spacers. Another variable that influences the structural stiffness is the use of standoffs and spacers. The depth of these pieces should be as short as practicable to allow a 1/2 inch cable deflection without contacting the backing plate.

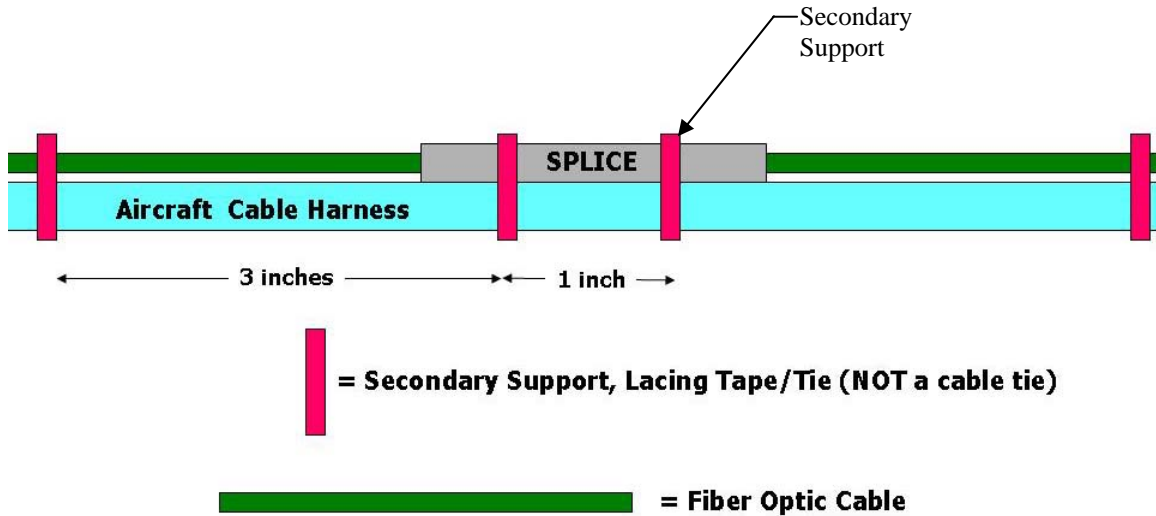

Figure 1. Secondary support spacing to secure mechanical splice to cable harness.

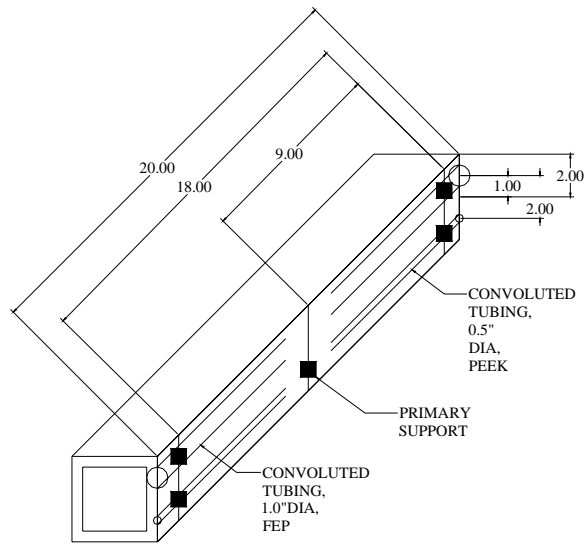

Figure 2. Test fixture construction illustrating the 2 different cable harnesses with mounting configurations.

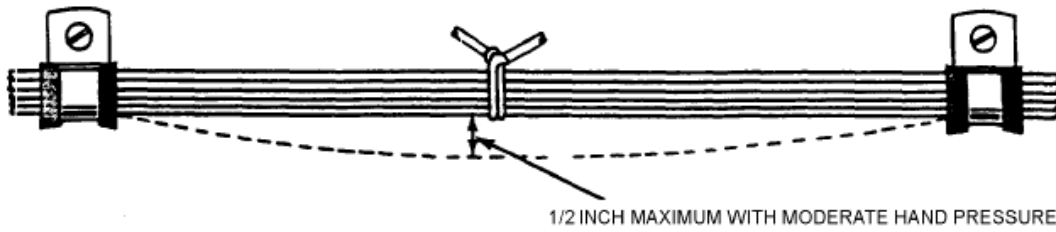

Figure 3. Allowed slack between primary supports.

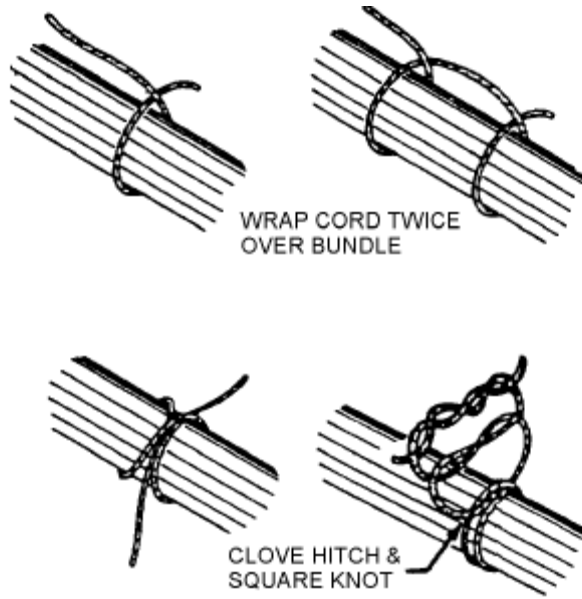

Figure 4. Lacing process for secondary support.

SIZE	CAGE	ESWBS	DRAWING NO.	REV
A	53711	499	8328898	-
SCALE: NONE		UCI	WT GRP	SHEET 17 of 17