

## TECHNICAL MANUAL

# CORROSION PREVENTION AND CONTROL, GROUND COMMUNICATIONS - ELECTRONIC EQUIPMENT (C-E)

BASIC AND ALL CHANGES HAVE BEEN MERGED  
TO MAKE THIS A COMPLETE PUBLICATION

DISTRIBUTION STATEMENT A - Approved for public release; distribution is unlimited. PA Case Number 06-11098. Submit recommended changes or problems with this Technical Order to 406 SCMS/GULAC, Robins AFB, GA 31098. Questions concerning technical content shall be referred to AFRL/RXSSR.

---

Published Under Authority of the Secretary of the Air Force

**31 JANUARY 2007**

**CHANGE 2 - 14 MARCH 2011**

TO 1-1-700

**LIST OF EFFECTIVE PAGES**

INSERT LATEST CHANGED PAGES. DESTROY SUPERSEDED PAGES.

NOTE: The portion of the text affected by the change is indicated by a vertical line in the outer margins of the page. Changes to illustrations are indicated by shaded or screened areas, or by miniature pointing hands.

Dates of issue for original and changed pages are:

Original.....0.....31 January 2007      Change .....2..... 14 March 2011

Change .....1.....21 July 2009

TOTAL NUMBER OF PAGES IN THIS PUBLICATION IS 252, CONSISTING OF THE FOLLOWING:

Page No.	*Change No.	Page No.	*Change No.	Page No.	*Change No.
Title .....	2	7-22 .....	0	12-40 Blank .....	0
A .....	2	7-23 .....	2		
i - iv .....	0	7-24 - 7-26 .....	0		
v .....	2	7-27 - 7-29 .....	1		
vi - xiii .....	0	7-30 - 7-37 .....	0		
xiv - xv .....	1	7-38 .....	1		
xvi - xvii .....	0	7-39 - 7-40 .....	2		
xviii .....	1	8-1 - 8-10 .....	0		
xix - xx .....	0	8-11 .....	2		
xxi .....	1	8-12 - 8-19 .....	0		
xxii .....	0	8-20 .....	1		
xxiii .....	1	8-21 - 8-32 .....	0		
xxiv - xxvii .....	0	8-33 .....	2		
xxviii Blank .....	0	8-34 .....	0		
1-1 .....	0	8-35 .....	1		
1-2 .....	1	8-36 - 8-40 .....	0		
2-1 .....	1	9-1 - 9-3 .....	0		
2-2 - 2-8 .....	0	9-4 Blank .....	0		
3-1 - 3-21 .....	0	10-1 - 10-4 .....	0		
3-22 Blank .....	0	10-5 .....	1		
4-1 - 4-4 .....	0	10-6 - 10-7 .....	2		
5-1 - 5-14 .....	0	10-8 .....	1		
6-1 - 6-3 .....	0	10-9 .....	0		
6-4 .....	1	10-10 .....	1		
6-5 .....	0	10-11 - 10-12 .....	0		
6-6 .....	1	10-13 .....	1		
6-7 .....	0	10-14 - 10-17 .....	0		
6-8 Blank .....	0	10-18 Blank .....	0		
7-1 - 7-2 .....	0	11-1 - 11-11 .....	0		
7-3 - 7-8 .....	1	11-12 - 11-13 .....	1		
7-9 .....	2	11-14 - 11-15 .....	0		
7-10 - 7-12 .....	1	11-16 .....	1		
7-13 - 7-16 .....	0	11-17 - 11-19 .....	0		
7-17 .....	1	11-20 .....	1		
7-18 .....	0	11-21 - 11-22 .....	0		
7-19 .....	2	12-1 - 12-18 .....	0		
7-20 .....	0	12-19 .....	1		
7-21 .....	2	12-20 - 12-39 .....	0		

\*Zero in this column indicates an original page.

## TABLE OF CONTENTS

Chapter	Page	Chapter	Page
LIST OF ILLUSTRATIONS .....	x	2.3.12	Plastic, Glass, and Ceramic Parts..... 2-6
LIST OF TABLES .....	xi	2.3.13	Rubber Parts .....
FOREWORD .....	xiii	2.3.14	Resistors .....
SAFETY SUMMARY .....	xvii	2.3.15	Spring Assemblies.....
1 INTRODUCTION .....	1-1	2.3.16	Sockets and Plug-In Devices.....
1.1 Corrosion Control Program.....	1-1	2.3.17	Fuses and Fuse Holders.....
1.1.1 Training .....	1-1	2.3.18	Panel Lamps .....
1.1.2 Maintenance .....	1-1	2.3.19	Shock Mounts .....
1.2 Safety .....	1-1	2.3.20	Safety Interlock Switches.....
1.2.1 Responsibility of Supervisors .....	1-1	2.3.21	Vibrators.....
1.2.2 Materials Handling.....	1-1	2.3.22	Motors, Generators, Blowers, and Fans .....
1.3 Materials.....	1-2	2.3.23	Waveguide Assemblies .....
2 GENERAL REQUIREMENTS .....	2-1	2.3.24	Protection for Spare Connectors and/or Receptacles .....
2.1 General .....	2-1	2.3.25	Moisture and Fungus Proofing.....
2.1.1 Specification Numbers .....	2-1	3 CORROSION THEORY .....	3-1
2.1.2 Material Substitutions .....	2-1	3.1 Purpose.....	3-1
2.2 Nonspecific General Requirements .....	2-1	3.2 Definition of Corrosion .....	3-1
2.2.1 Workmanship .....	2-1	3.3 Chemical Definitions .....	3-1
2.2.2 Overall Cleanliness and Cleaning .....	2-1	3.3.1 Atom.....	3-1
2.2.3 Soldering .....	2-2	3.3.2 Electron .....	3-1
2.2.4 Riveting .....	2-3	3.3.3 Ions.....	3-1
2.2.5 Welding.....	2-4	3.3.4 Electrolyte .....	3-1
2.2.6 Wiring and Cabling (Wire and Cable Runs).....	2-4	3.4 Theory of Corrosion.....	3-1
2.2.7 Grounding .....	2-4	3.5 Development of Corrosion.....	3-3
2.3 Specific General Requirements.....	2-4	3.6 Factors Influencing Corrosion .....	3-3
2.3.1 Fixed Capacitors .....	2-4	3.6.1 Type of Metal.....	3-3
2.3.2 Variable Capacitors.....	2-4	3.6.2 Dissimilar Metal Coupling (Galvanic Corrosion) .....	3-4
2.3.3 Controls .....	2-4	3.6.3 Anode and Cathode Surface Area.....	3-4
2.3.4 Dials and Pointers .....	2-5	3.6.4 Temperature .....	3-4
2.3.5 Frameworks, Cabinets, and Mechanical Assemblies .....	2-5	3.6.5 Heat Treatment and Grain Direction.....	3-4
2.3.6 Finishes .....	2-5	3.6.6 Electrolytes.....	3-5
2.3.7 Gaskets .....	2-5	3.6.7 Oxygen.....	3-5
2.3.8 Hardware .....	2-6	3.6.8 Electrolyte Concentration .....	3-5
2.3.9 Keys and Switches .....	2-6	3.6.9 Biological Organisms.....	3-5
2.3.10 Mounting of Parts.....	2-6	3.6.10 Time .....	3-5
2.3.11 Mechanical Parts .....	2-6	3.7 Types of Corrosion.....	3-5
		3.7.1 Uniform Surface Corrosion.....	3-5
		3.7.2 Galvanic Corrosion .....	3-5

## TABLE OF CONTENTS - CONTINUED

Chapter	Page	Chapter	Page
3.7.3	Pitting Corrosion.....3-5	3.9.18	Industrial and Ship Emitted Air Pollutants .....3-19
3.7.4	Intergranular Corrosion.....3-6	3.9.19	Animal Damage .....3-19
3.7.5	Exfoliation Corrosion.....3-6	3.9.20	Microorganisms .....3-19
3.7.6	Crevice/Concentration Cell Corrosion.....3-6	3.9.21	Bacteria .....3-19
3.7.7	Metal Ion Concentration Cells .....3-7	3.9.22	Microbial Growth Requirements .....3-19
3.7.8	Oxygen Concentration Cells .....3-8	3.9.23	Microbial Nutrients .....3-19
3.7.9	Active/Passive Cells.....3-8	3.10	Degradation of Non-Metals .....3-19
3.7.10	Filiform Corrosion .....3-8	3.11	Preventative Maintenance .....3-20
3.7.11	Fretting Corrosion .....3-9	3.12	Corrosion Effects on Ground Electrical and Communications, Electronic and Meteorological Equipment (C-E-M) .....3-20
3.8	Metals Affected By Corrosion .....3-9	3.12.1	Grounding and Bonding Connections .....3-20
3.8.1	Magnesium.....3-9	3.12.2	Dissimilar Metal Junctions, Corrosion Effects .....3-20
3.8.2	Steel.....3-11	3.12.3	EMI Shielding.....3-20
3.8.3	Aluminum .....3-11	3.12.4	EMI Seals and Gaskets, Corrosion Effects .....3-21
3.8.4	Anodized Aluminum.....3-11	3.12.5	Electrostatic Discharge Sensitivity (ESDS) .....3-21
3.8.5	Copper and Copper Alloys.....3-13	3.12.6	ESD Protective Systems, Corrosion Effects .....3-21
3.8.6	Cadmium.....3-13		
3.8.7	CRES/Stainless Steel .....3-16	4	COMPOSITE AND NON-METALLIC MATERIAL DEGRADATION AND REPAIR .....4-1
3.8.8	Nickel and Chromium.....3-16	4.1	Purpose.....4-1
3.8.9	Silver, Platinum, and Gold.....3-16	4.2	Material Substitutions .....4-1
3.8.10	Graphite (Carbon) Fiber/Epoxy Composites and Fiberglass Materials .....3-16	4.3	Workmanship and Safety .....4-1
3.9	Corrosive Environments .....3-16	4.3.1	Components and Parts .....4-1
3.9.1	Moisture .....3-16	4.3.2	Dimensions and Tolerances .....4-1
3.9.2	Condensed Moisture .....3-16	4.3.3	Tools and Tooling .....4-1
3.9.3	Effect of Moisture .....3-17	4.3.4	Safety and Health.....4-1
3.9.4	Temperature .....3-17	4.4	General Requirements.....4-1
3.9.5	Salt Atmospheres .....3-17	4.4.1	Wood.....4-1
3.9.6	Ozone .....3-17	4.4.1.1	Inspection.....4-1
3.9.7	Other Industrial Pollutants .....3-17	4.4.1.2	Repair.....4-1
3.9.8	Sand, Dust, and Volcanic Ash .....3-17	4.4.1.3	Finish .....4-2
3.9.9	Solar Radiation.....3-17	4.4.2	Composite Materials .....4-2
3.9.10	Climate .....3-18	4.4.3	Fabric and Leather .....4-2
3.9.11	Desert .....3-18	4.4.4	Plastic, Ceramics and Glass .....4-2
3.9.12	Temperate Zones.....3-18	4.4.5	Rubber.....4-3
3.9.13	Tropics .....3-18		
3.9.14	Factors of Influence in Tropical Environments .....3-18		
3.9.15	Manufacturing.....3-18		
3.9.16	Storage .....3-18		
3.9.17	Shipment .....3-18		

## TABLE OF CONTENTS - CONTINUED

Chapter	Page	Chapter	Page		
4.4.6	Felt .....	4-3	5.10.1	Preservation Methods.....	5-4
4.4.7	Honeycomb and Foam-Beam.....	4-3	5.10.2	MIL-STD-2073-1 .....	5-4
4.4.8	Gaskets .....	4-3	5.11	Contact Preservatives for Metals .....	5-4
4.4.9	Lenses and Optical Surfaces .....	4-4	5.12	Volatile Corrosion Inhibitors (VCI).....	5-4
4.4.10	Labels .....	4-4	5.12.1	VCI Coatings.....	5-4
4.5	Degradation Prevention.....	4-4	5.12.2	Impregnated Papers .....	5-4
4.5.1	Weather .....	4-4	5.13	Limitations of VCI .....	5-4
4.5.2	Damage .....	4-4	5.14	Effect of Heat, Light, Acids, and Strong Alkalis on VCIs .....	5-4
4.5.3	Normal Wear .....	4-4	5.15	Precautions for VCI Use .....	5-5
5	PACKAGING (STORAGE AND SHIPPING) .....	5-1	5.16	VCI Use.....	5-5
5.1	General .....	5-1	5.16.1	VCI Protection Usage .....	5-5
5.1.1	Packaging .....	5-1	5.16.2	VCI Usage Benefits .....	5-5
5.1.2	Military Specifications, Standards, and Manuals .....	5-1	5.17	VCI Packaging Materials Specifications .....	5-5
5.2	Levels of Protection .....	5-1	5.17.1	MIL-PRF-3420, Packaging Materials, Volatile Corrosion Inhibitor Treated, Opaque .....	5-5
5.2.1	Military Level of Preservation .....	5-1	5.17.2	MIL-PRF-22019, Barrier Materials, Transparent, Flexible, Sealable, VCI Treated .....	5-5
5.2.2	Military Level of Packing .....	5-1	5.17.3	MIL-B-22020, Bags, Transparent, Flexible, Sealable, VCI Treated.....	5-5
5.3	Cleaning .....	5-1	5.17.4	MIL-I-22110, Inhibitors, Corrosion, Volatile, Crystalline Powder .....	5-5
5.3.1	Contaminated Surfaces .....	5-1	5.17.5	Other Forms of VCIs.....	5-5
5.3.2	Post Wash Protection .....	5-1	5.18	Application of VCI.....	5-5
5.4	Cleaning Compounds .....	5-1	5.19	Desiccants .....	5-6
5.4.1	Alkaline Cleaners .....	5-2	5.19.1	Usage.....	5-6
5.4.2	MIL-PRF-87937, Types I and IV and MIL-PRF-85570, Types I and II.....	5-2	5.19.2	Application.....	5-6
5.4.3	MIL-PRF-87937, Type IV and MIL-PRF-85570, Type II.....	5-2	5.19.3	Usage Areas .....	5-6
5.5	Solvents .....	5-2	5.19.4	Moisture .....	5-6
5.6	Item Cleaning Requirements.....	5-2	5.19.5	Benefits .....	5-6
5.6.1	Cleaning Materials Knowledge.....	5-2	5.20	Desiccant Application .....	5-6
5.7	Container Cleaning Requirements .....	5-2	5.21	Cushioning .....	5-7
5.7.1	Shipping Container Protection .....	5-2	5.21.1	Purpose.....	5-7
5.7.2	Unprotected Shipping Containers .....	5-3	5.21.2	MIL-HDBK-304 .....	5-7
5.7.3	The Effects of Moisture on Equipment Cases (Containers) .....	5-3	5.22	Methods of Cushioning .....	5-7
5.8	Basic Principles of Preservative Protection .....	5-4	5.22.1	Floated Items .....	5-7
5.8.1	Preservations .....	5-4	5.22.2	Floated Pack .....	5-7
5.8.2	Barriers .....	5-4	5.22.3	Corner Pads/Blocks and Side Pads .....	5-7
5.8.3	Volatile Corrosion Inhibitors .....	5-4	5.22.4	Shock Mounts .....	5-8
5.9	Classification of Preservatives .....	5-4			
5.10	Methods of Preservation .....	5-4			

## TABLE OF CONTENTS - CONTINUED

Chapter	Page	Chapter	Page
5.23	Cushioning vs. Dunnage .....5-8	6.2	Detailed Requirements .....6-1
5.23.1	Dunnage .....5-8	6.2.1	Leather .....6-1
5.23.2	Cushioning .....5-8	6.2.2	Canvas and/or Duck .....6-1
5.23.3	Functions of Cushioning .....5-9	6.2.3	Cork .....6-2
5.24	Cushioning Materials .....5-10	6.2.4	Paper .....6-2
5.24.1	Bound Fiber (PPP-C-1120) .....5-10	6.2.5	Webbing .....6-3
5.24.2	Cellulosic (A-A-1898) .....5-10	6.2.6	Felt .....6-3
5.24.3	Low Density Polypropylene Foam .....5-10	6.2.7	Treatment of Metal Parts .....6-3
5.24.4	Solid and Corrugated Fiberboard .....5-10	6.3	Moisture and Fungus Resistant Varnish Treatment of Ground Communications, Electronic, Meteorological (C-E-M) and Associated Electrical Equipment .....6-4
5.24.5	Solid Fiberboard (MIL-F-26862) .....5-10	6.3.1	Retreatment Criteria .....6-4
5.24.6	Wrapping Paperboard (A-A-1051) .....5-10	6.3.2	Cleaning .....6-4
5.24.7	Flexible Open Cell Plastic Film (A-A-3129) .....5-10	6.3.2.1	Varnish Treatment Removal .....6-4
5.24.8	Polystyrene Expanded, Resilient .....5-10	6.3.2.2	Final Cleaning and Debris Removal .....6-4
5.24.9	Closed Cell Foam Plank (A-A-59136), Polyethylene and Other Polyolefin .....5-10	6.4	Preparation for Retreatment .....6-5
5.24.10	Rigid or Flexible Polyurethane Foam (MIL-PRF-26514) .....5-13	6.4.1	Masking .....6-5
5.24.11	Packaging (Flexible Closed Cell Plastic Film for Long Shipping Cycle Applications) (PPP-C-795) .....5-13	6.4.2	Drying of Equipment .....6-5
5.25	Method 20 - Preservative Coating Only with Greaseproof Wrap .....5-13	6.4.3	Methods of Treatment .....6-5
5.25.1	Concept .....5-13	6.4.4	Preparing Coating Material for Application .....6-6
5.25.2	Intended Use .....5-13	6.4.5	Coverage .....6-6
5.25.3	Determining Factor .....5-13	6.4.6	Exemptions .....6-7
5.26	Method 30 - Waterproof/Waterproof- Greaseproof Protection .....5-13	6.4.7	Final Drying of Coated Materials .....6-7
5.26.1	Concept .....5-13	6.4.8	Adjusting and Final Testing .....6-7
5.26.2	Intended Use .....5-13	6.4.9	Marking of Treated Equipment .....6-7
5.27	Method 40 - Water Vapor Proof Protection .....5-14	6.4.10	Determination of Coverage .....6-7
5.27.1	Concept .....5-14	7	Preventative Maintenance and Refinishing on Structural Components .....7-1
5.27.2	Intended Use .....5-14	7.1	Purpose .....7-1
5.27.3	Critical Parts .....5-14	7.1.1	Interpretation .....7-1
5.27.4	Usage Without Contact Preservation .....5-14	7.1.2	Technical Manuals .....7-1
5.28	Method 50 - Water Vapor Proof Protection with Desiccant .....5-14	7.2	Corrosion Protection .....7-1
5.28.1	Concept .....5-14	7.3	Preventative Maintenance .....7-1
5.28.2	Sub-Method Requirements .....5-14	7.3.1	Cleaning .....7-1
5.28.3	Sub-Methods of Method 50 .....5-14	7.3.1.1	Cleaning Compounds .....7-2
5.28.4	Intended Use .....5-14	7.3.1.1.1	Alkaline Cleaners .....7-2
6	MOISTURE AND FUNGUS PROOFING .....6-1	7.3.1.1.2	MIL-PRF-87937, Type I (Terpene Solvent Based) and MIL-PRF-85570, Type I (Aromatic Solvent Based) .....7-2
6.1	General .....6-1	7.3.1.1.3	MIL-PRF-87937, Type IV and MIL-PRF-85570, Type II .....7-2

## TABLE OF CONTENTS - CONTINUED

Chapter	Page	Chapter	Page
7.3.1.2	Cleaning Equipment..... 7-13	7.7.1	Iron and Plain Low Carbon Steel..... 7-25
7.3.1.2.1	High Pressure/Hot Wash Equipment .... 7-13	7.7.2	Aluminum ..... 7-27
7.3.1.2.2	Portable, 15 gallon, Foam Generating, Cleaning Unit ..... 7-13	7.7.3	Magnesium..... 7-28
7.3.1.2.3	Portable, 45 gallon, Foam Generating Cleaning Unit ..... 7-14	7.7.4	Zinc and Cadmium Plated Surfaces ..... 7-29
7.4	Lubrication ..... 7-14	7.7.5	Tin on Ferrous Base Metal ..... 7-31
7.4.1	Conventional Lubricants ..... 7-14	7.7.6	Tin on Copper and Copper Base Alloys ..... 7-32
7.4.2	Solid Film Lubricants..... 7-15	7.7.7	Nickel on Copper and Copper Base Alloys ..... 7-33
7.4.3	Application of Conventional Lubricants ..... 7-17	7.7.8	Nickel on Ferrous Base Metal..... 7-34
7.5	Preservation..... 7-17	7.7.9	Stainless Steel (CRES)..... 7-35
7.5.1	CPC Formulation ..... 7-17	7.7.10	Bright Chromium on Ferrous, Copper, and Copper Alloy Base Metals ..... 7-36
7.5.2	Operational Preservation ..... 7-17	7.7.11	Lead on Copper, Copper Alloy, and Ferrous Base Metals..... 7-37
7.5.3	Non-Operational Preservation..... 7-17	7.8	MIL-C-10578 Metal Conditioner..... 7-37
7.5.4	Types of CPCs ..... 7-18	7.8.1	Type I Application ..... 7-38
7.5.4.1	Water Displacing Compounds ..... 7-18	7.8.2	Type II Application ..... 7-38
7.5.4.1.1	Water Displacing, Hard Film ..... 7-18	7.9	Special Applications for Iron and Steel ..... 7-38
7.5.4.2	Non-Water Displacing Compounds ..... 7-18	7.9.1	Finishing..... 7-38
7.5.5	Time Limitations of CPCs ..... 7-18	7.9.2	Screws Used for Wood ..... 7-38
7.5.6	Description of CPCs..... 7-19	7.9.3	Screws Not Used for Wood ..... 7-38
7.5.6.1	MIL-PRF-81309; Corrosion Preventive Compound, Water Displacing, Ultra Thin Film and MIL-L-87177; Lubricants, Corrosion Preventive, Water Displacing, Synthetic ..... 7-19	7.9.4	Moving Parts ..... 7-38
7.5.6.2	MIL-PRF-81309, Type II and MIL-L-87177, Grade B ..... 7-19	7.9.5	Mechanical Use Parts..... 7-38
7.5.6.3	MIL-PRF-81309, Type III and MIL-L-87177, Grade B ..... 7-19	7.10	Chemical Finishes ..... 7-38
7.5.6.4	MIL-DTL-85054 Corrosion Preventive Compound, Clear ..... 7-19	7.11	Special Cases..... 7-38
7.5.6.5	MIL-PRF-16173 Corrosion Preventive Compound, Solvent Cutback, Cold Application..... 7-19	7.11.1	Threaded Parts..... 7-38
7.5.6.6	MIL-PRF-63460 Lubricant, Cleaner, and Preservative ..... 7-20	7.11.2	Springs ..... 7-39
7.6	Preservation of Specific Areas ..... 7-22	7.11.3	Wood ..... 7-39
7.6.1	Preservation Application Methods ..... 7-24	7.12	Rust Converters ..... 7-39
7.6.1.1	Brushing ..... 7-24	7.12.1	Recommended Rust Cover Products..... 7-39
7.6.1.2	Dipping..... 7-25	8	PREVENTATIVE MAINTENANCE ON ELECTRONIC COMPONENTS ..... 8-1
7.6.1.3	Spraying ..... 7-25	8.1	General ..... 8-1
7.7	Finishing..... 7-25	8.2	Description ..... 8-1
		8.3	Repair Sequence..... 8-1
		8.3.1	Inspect Component ..... 8-1
		8.3.2	Clean Component and Remove Corrosion..... 8-1
		8.3.3	Identify the Conformal Coating ..... 8-1
		8.3.4	Remove the Conformal Coating ..... 8-2

## TABLE OF CONTENTS - CONTINUED

Chapter	Page	Chapter	Page
8.3.5	Repair Damage.....8-2	8.6.2.3	Aqueous Ultrasonic Cleaner .....8-25
8.3.6	Reapply Conformal Coating .....8-2	8.6.2.3.1	Solvent Ultrasonic Cleaner .....8-26
8.4	Electronic-Specific Principles and Descriptions .....8-2	8.6.2.3.2	Water Base Solvent Spray Booth.....8-26
8.4.1	Materials and Their Electronic Applications .....8-2	8.6.2.3.3	Abrasive Tools .....8-26
8.4.2	Corrosive Conditions .....8-2	8.6.3	Cleaning Procedures/Selection Criteria .....8-27
8.4.2.1	Moisture .....8-2	8.6.3.1	Hazards of Cleaning .....8-27
8.4.2.2	Salt .....8-2	8.6.3.2	When to Clean .....8-27
8.4.2.3	Other Fluids .....8-2	8.6.3.3	Precleaning Treatment .....8-27
8.4.2.4	Temperature .....8-2	8.6.3.4	Cleaning and Drying Restrictions .....8-27
8.4.2.5	Pollution .....8-2	8.6.3.5	Hand Cleaning Methods and Materials .....8-28
8.4.2.6	Sand and Dust .....8-2	8.6.3.6	Removal of Fingerprints .....8-28
8.4.2.7	Biological Factors (Microorganism, Insect, Animal).....8-2	8.6.3.7	Removal of Solder Flux Residue .....8-29
8.4.2.8	Fumes, Vapors, Residues from Assembly Processes .....8-3	8.6.3.8	Removal of Silicone Lubricant .....8-29
8.4.2.9	Solder Flux Corrosion .....8-3	8.6.3.9	Removal of Bacteria and Fungi .....8-29
8.4.2.10	Equipment Handling .....8-3	8.6.3.10	Removal of Dust, Dirt, Grease, and Oil .....8-29
8.4.2.11	Packaging .....8-3	8.6.4	Drying Equipment and Procedures .....8-30
8.4.2.12	Storage .....8-3	8.6.4.1	Air Drying .....8-30
8.4.2.13	Shipment .....8-3	8.6.4.2	Hot Air Blower .....8-30
8.5	Inspection .....8-3	8.6.4.3	Circulating Air Drying Oven .....8-30
8.5.1	Corrosion-Prone Areas.....8-3	8.6.4.4	Forced Air Drying Oven .....8-30
8.5.1.1	Moisture and Fluid Intrusion Sources .....8-3	8.6.4.5	Vented Drying Oven .....8-30
8.5.1.2	Electromechanical .....8-3	8.6.4.6	Vacuum Drying Oven .....8-30
8.5.1.3	Electronic .....8-4	8.6.5	Preservatives .....8-31
8.5.2	Recognizing Corrosion .....8-4	8.6.5.1	When to Preserve .....8-31
8.5.3	Effects of Solder Flux .....8-4	8.6.5.2	What to Preserve .....8-31
8.5.4	Effects of Microbial Presence .....8-4	8.6.5.3	Preservative Materials.....8-31
8.5.5	Effects of Insect and Animal Presence .....8-4	8.6.6	Lubricants .....8-31
8.5.6	Inspection Procedures .....8-4	8.6.7	Packaging .....8-32
8.5.6.1	General .....8-4	8.7	Corrosion Removal .....8-33
8.5.6.2	Water Intrusion .....8-5	8.7.1	Materials .....8-33
8.5.6.3	Evaluation of Damage.....8-7	8.7.1.1	Hand Rubbing/Abrasion .....8-33
8.6	Cleaning .....8-7	8.7.1.2	Portable Mini-Abrasive Unit .....8-33
8.6.1	Required Materials and Support Equipment .....8-7	8.7.1.3	Hand-Held Abrasive Tool .....8-33
8.6.2	Materials and Equipment .....8-25	8.7.1.4	Chemical Paint Removers.....8-33
8.6.2.1	Materials .....8-25	8.8	Surface Treatment .....8-33
8.6.2.2	Equipment .....8-25	8.8.1	Chemical Conversion Coatings .....8-33
		8.8.2	Protective Coatings .....8-34
		8.8.3	Encapsulates.....8-34



## TABLE OF CONTENTS - CONTINUED

Chapter	Page	Chapter	Page
8.8.3.1	Potting Compounds ..... 8-34	9.1.3	General Inspections ..... 9-1
8.8.3.1.1	Materials ..... 8-34	9.1.4	Detailed Inspections ..... 9-1
8.8.3.1.2	Precautions ..... 8-34	9.2	Inspection Methods ..... 9-1
8.8.3.1.3	Reverted Potting Compounds ..... 8-35	9.2.1	Visual Inspection ..... 9-1
8.8.3.2	Conformal Coatings ..... 8-35	9.2.1.2	Evidence of Corrosion ..... 9-2
8.8.3.3	Fungus-Proof Coatings ..... 8-35	9.2.2	Depth Gauge, Mechanical Type ..... 9-2
8.8.3.3.1	Items to be Protected Against Fungus-Proof Varnish ..... 8-35	9.2.3	Optical Depth Micrometers ..... 9-2
8.8.3.3.2	Application ..... 8-36	9.2.4	Fluorescent Penetrate Inspection ..... 9-2
8.8.3.3.3	Curing of Varnish ..... 8-36	9.2.4.1	Limitations of Penetrate Inspection ..... 9-2
8.8.3.3.4	Precautions ..... 8-36	9.2.4.1.1	Restricted Flaw Openings ..... 9-3
8.8.4	Sealants ..... 8-37	9.2.4.1.2	Smeared Metal ..... 9-3
8.8.4.1	Suitable for Electronics ..... 8-37	9.2.4.1.3	Porous Surfaces ..... 9-3
8.8.4.2	Unsuitable for Electronics (Containing Acetic Acids) ..... 8-37	9.2.5	Coin Tap-Test (Non-Destructive Inspection Method) ..... 9-3
8.9	Handling of Specific Equipment/ Components ..... 8-37	9.3	Evaluation of Corrosion Damage ..... 9-3
8.9.1	Bonding/Grounding ..... 8-37	9.4	Degrees of Corrosion ..... 9-3
8.9.1.1	Cleaning and Corrosion Removal ..... 8-37	9.4.1	Light Corrosion ..... 9-3
8.9.1.2	Preservation ..... 8-38	9.4.2	Moderate Corrosion ..... 9-3
8.9.1.3	Application ..... 8-38	9.4.3	Severe Corrosion ..... 9-3
8.9.2	EMI Shielding ..... 8-38	10	CORROSION PRONE AREAS ..... 10-1
8.9.2.1	Effects of Corrosion on EMI Shielding ..... 8-38	10.1	Common Areas ..... 10-1
8.9.2.2	Addressing Corrosion ..... 8-38	10.2	Dissimilar Metals ..... 10-1
8.9.2.2.1	Inspection ..... 8-38	10.3	Fasteners ..... 10-1
8.9.2.2.2	Treatment ..... 8-39	10.4	Rivets ..... 10-3
8.9.3	ESD Sensitive Components ..... 8-39	10.5	Mating Surfaces and Crevices ..... 10-3
8.9.3.1	Effects of Corrosion ..... 8-39	10.5.1	Faying Surface Sealing ..... 10-3
8.9.3.2	Recommended Practices for Handling ESD Sensitive Components ..... 8-39	10.5.2	Fillet Sealing ..... 10-3
8.9.3.3	Addressing Corrosion ..... 8-40	10.6	Spot-Welded Assemblies ..... 10-4
8.9.3.3.1	Preventive Maintenance and Control ..... 8-40	10.7	Hinges and Latches ..... 10-5
8.9.3.3.2	ESD Protective System Repair and Treatment ..... 8-40	10.7.1	Van and Shelter (Fixed and Mobile) Hinges and Latches ..... 10-5
9	INSPECTION ..... 9-1	10.7.2	Equipment Hinges and Latches ..... 10-6
9.1	Purpose ..... 9-1	10.8	Steel Cables ..... 10-8
9.1.1	Responsibility ..... 9-1	10.9	Water Entrapment Areas and Drain Holes ..... 10-9
9.1.2	Frequency of Inspection ..... 9-1	10.10	Battery Compartments and Battery Vent Openings ..... 10-9
		10.11	Natural and Synthetic Rubber Parts ..... 10-9
		10.12	Electrical Components and Other Components ..... 10-10
		10.13	Bonding/Grounding ..... 10-10

## TABLE OF CONTENTS - CONTINUED

Chapter	Page	Chapter	Page
10.13.1	Corrosion Prevention and Treatment for Grounding and Bonding Connections .....10-11	11.6	3M Co. Scotch-Brite™ Finishing Flap Brushes .....11-6
10.13.2	Electrical Bonding/Grounding .....10-11	11.6.1	Flap Brushes .....11-6
10.14	Antennas and Radar Surfaces .....10-11	11.6.2	Abrasive Flap Wheels .....11-6
10.15	Van and Trailer Undercarriages .....10-11	11.7	Abrasive Cloth and Paper .....11-6
10.15.1	Shelter Underbody .....10-11	11.8	Powered Wire Brushes .....11-6
10.15.2	Shelters Skids .....10-12	11.9	Rotary Files .....11-6
10.15.2.1	Repair of Damaged Shelter Skids .....10-12	11.10	3M Co. Roloc™ Disc and Radial Disc Abrasives .....11-6
10.15.2.2	Replacing Damaged Shelter Skids .....10-13	11.10.1	Roloc™ Discs .....11-6
10.16	Van and Trailer Attachment Points (Including Lift Rings) .....10-13	11.10.2	Radial Type Plastic Bristle Disc™ .....11-7
10.16.1	Corrosion Prevention and Control for Lift Rings .....10-14	11.11	Abrasive Blasting .....11-7
10.17	Razor Edge Doors .....10-14	11.11.1	Conventional Equipment .....11-7
10.18	Magnesium Alloy Components .....10-15	11.11.2	Control of Mechanical Damage During Abrasive Blasting .....11-8
10.19	EMI Shielding .....10-15	11.11.3	Abrasive Blasting Corrosion Removal .....11-8
10.20	Electrostatic Discharge (ESD) Components .....10-16	11.11.3.1	Personal Protection .....11-9
11	CORROSION REMOVAL .....11-1	11.11.3.2	Abrasive Blasting Procedures .....11-9
11.1	General .....11-1	11.12	Non-Powered and Powered Tool Corrosion Removal .....11-9
11.1.1	Training .....11-1	11.12.1	Personal Protection .....11-9
11.1.2	Corrosion Risk .....11-1	11.12.2	Mechanical Damage .....11-10
11.1.3	Maintenance Level .....11-1	11.12.3	Non-Powered Tool Corrosion Removal Procedures .....11-10
11.2	Corrective Actions .....11-1	11.12.4	Powered Tool Corrosion Removal .....11-10
11.2.1	Exposure .....11-1	11.13	Chemical Corrosion Removal .....11-10
11.2.2	Mechanical Procedures .....11-1	11.13.1	Aluminum Alloys .....11-10
11.3	Corrosion Removal Methods .....11-1	11.13.1.1	Preparation .....11-10
11.3.1	Mechanical Methods .....11-2	11.13.1.2	Chemical Corrosion Removal Materials for Aluminum Alloys .....11-11
11.3.1.1	Mechanical Compatibility .....11-2	11.13.1.2.1	SAE AMS-1640 (MIL-C-38334, Type I) Corrosion Removing Compound Uses and Mixing Instructions .....11-11
11.3.1.2	Material Compatibility .....11-2	11.13.1.2.2	Uses for Semco® Pasa-Jell 102 .....11-11
11.4	Non-Powered Tools and Materials .....11-2	11.13.1.2.3	MIL-DTL-81706 (MIL-C-81706), Class 1A, Uses and Mixing Instructions .....11-12
11.4.1	Abrasive Mats .....11-2	11.13.2	Magnesium Alloys .....11-13
11.4.2	Abrasive Cloth .....11-2	11.13.2.1	Preparation .....11-13
11.4.3	Abrasive Paper .....11-2	11.13.2.2	Chemical Corrosion Removal Materials for Magnesium Alloys .....11-13
11.4.4	Wire Brushes .....11-2		
11.4.5	Scrapers .....11-2		
11.5	Power Tools and Materials .....11-3		
11.5.1	Pneumatic Drill Motors .....11-5		
11.5.2	Pneumatic Sanders .....11-5		

## TABLE OF CONTENTS - CONTINUED

Chapter	Page	Chapter	Page
11.13.2.3	Application of Organic Coatings ..... 11-14	11.13.6.2.1	Acid Pickling Solutions ..... 11-20
11.13.3	Ferrous Metal (Steel) Alloys Other Than Stainless Steels (CRES) ..... 11-14	11.13.6.2.2	SAE AMS-1640 (MIL-C-38334) Corrosion Removal Compound Solutions ..... 11-20
11.13.3.1	Preparation ..... 11-14	11.13.6.3	Application of Organic Coatings ..... 11-20
11.13.3.2	Chemical Corrosion Removing Materials for Ferrous Metal Alloys Other Than Stainless Steels (CRES) ..... 11-14	11.13.7	Plated and Phosphate Surfaces ..... 11-21
11.13.3.2.1	MIL-C-10578 Corrosion Removing and Metal Conditioning Compound (Phosphoric Acid Base) ..... 11-14	11.13.7.1	Preparation ..... 11-21
11.13.3.2.2	A-A-59260 (MIL-C-14460, Type I) Corrosion Removing Compound, Sodium Hydroxide Base; for Electrolytic or Immersion Application ..... 11-15	11.13.7.2	Treatment of Corroded Areas on Cadmium or Zinc Plated Surfaces ..... 11-22
11.13.4	Stainless Steel (CRES) and Nickel Based Alloys ..... 11-15	11.13.7.3	Treatment of Corroded Areas on Plated Surfaces Except Cadmium or Zinc Plating ..... 11-22
11.13.4.1	Preparation ..... 11-16	11.13.7.4	Treatment of Corroded Areas on Phosphate Surfaces ..... 11-22
11.13.4.2	Chemical Corrosion Removing Materials for Stainless Steel (CRES) and Nickel Based Alloys ... 11-18	11.13.8	Application of Organic Coatings ..... 11-22
11.13.4.2.1	Semco® Pasa-Jell 101 ..... 11-18	12	SEALANTS ..... 12-1
11.13.4.2.2	MIL-C-10578, Type III Corrosion Removing and Metal Conditioning Compound (Phosphoric Acid Base)/Inhibited ..... 11-18	12.1	Purpose ..... 12-1
11.13.4.2.3	Acid Pickling for Corrosion Removal ..... 11-18	12.2	Applications ..... 12-1
11.13.5	Copper and Copper Based Alloys ..... 11-19	12.3	Sealing Compounds ..... 12-1
11.13.5.1	Preparation ..... 11-19	12.3.1	Sealant Packaging ..... 12-1
11.13.5.2	Chemical Corrosion Removing Materials for Copper and Copper Based Alloys ..... 11-19	12.3.1.1	Two-Part Kit (KT) ..... 12-1
11.13.5.2.1	MIL-C-10578, Type III Corrosion Removing and Metal Conditioning Compound (Phosphoric Acid Base)/Inhibited ..... 11-19	12.3.1.2	Cartridge (CA) ..... 12-1
11.13.5.2.2	A-A-55828 (O-S-809) Sulfuric Acid Solutions ..... 11-19	12.3.1.3	Premixed and Frozen (PMF) ..... 12-1
11.13.6	Titanium and Titanium Based Alloys ..... 11-20	12.3.2	Polysulfide, Polyurethane, and Polythioether Sealing Compounds .... 12-1
11.13.6.1	Preparation ..... 11-20	12.3.3	Silicone Sealing Compounds ..... 12-2
11.13.6.2	Chemical Corrosion Removal Materials for Titanium and Titanium Based Alloys ..... 11-20	12.3.4	Adhesion Promoters ..... 12-11
		12.3.5	SAE AMS 3255 Oil and Water Resistant, Expanded Polytetrafluoroethylene Sealing Tape (EPTFE) (Skyflex®) ..... 12-11
		12.3.6	Av-Dec® Polyurethane Sealant Tapes and Two Component Sealants ..... 12-11
		12.4	Equipment ..... 12-11
		12.4.1	Sealant Gun ..... 12-11
		12.4.2	Application Nozzles ..... 12-11
		12.4.3	Injection Gun ..... 12-12
		12.4.4	Sealant Kits (Semkits®) ..... 12-18
		12.4.5	Sealant Removal and Application Tools ..... 12-19
		12.5	Sealant Mixing ..... 12-19

## TABLE OF CONTENTS - CONTINUED

Chapter	Page	Chapter	Page
12.5.1	Application Life .....12-19	12.7.2	Fillet Sealing .....12-31
12.5.2	Storage Instructions .....12-25	12.7.3	Injection Sealing .....12-31
12.5.3	Mixing MIL-PRF-81733, Type III Sprayable Sealant Coating .....12-25	12.7.4	Fastener Sealing .....12-31
12.6	Sealant Application Procedures .....12-26	12.7.5	Form-In-Place (FIP) Gasket Sealant Repair .....12-31
12.6.1	Cleaning .....12-26	12.7.6	SAE AMS 3255 EPTFE (Skyflex®) and Av-DEC® HT3000 and HT3935-7 Sealing Tape Gasket Repair .....12-32
12.6.2	Masking .....12-26	12.7.7	External Structure .....12-34
12.6.3	Adhesion Promoters .....12-27	12.7.8	Depressions .....12-34
12.6.4	Brush Spatula or Caulking Gun Application .....12-27	12.7.9	Damaged Sealant .....12-35
12.6.5	Spray Gun Application .....12-28	12.7.10	Extensive Repair .....12-35
12.6.6	Peel and Stick Application; AMS 3255 EPTFE Skyflex® and Av-DEC® HT3935-7 and HT3000 Sealing Tapes .....12-28	12.7.11	High Temperature Areas .....12-35
12.7	Sealing of Specific Areas .....12-29	12.7.12	Low Temperature Curing .....12-35
12.7.1	Faying Surface Sealing .....12-29	12.8	Storage/Shelf Life Control of Sealants .....12-36

## LIST OF ILLUSTRATIONS

Number	Title	Page	Number	Title	Page
3-1	Simplified Corrosion Cell .....3-2	3-2	3-16	Schematic of the Development of Filiform Corrosion on an Aluminum Alloy .....3-11	3-11
3-2	Elimination of Corrosion by Application of an Organic Film to a Metal Surface .....3-2	3-2	3-17	Galvanic Series of Metals and Alloys in Sea Water .....3-12	3-12
3-3	Effect of Sea Water on Galvanic Corrosion .....3-3	3-3	3-18	Magnesium Corrosion Products .....3-13	3-13
3-4	Galvanic Corrosion in a Flashlight Battery .....3-4	3-4	3-19	Steel Corrosion Products (Rust) .....3-13	3-13
3-5	Effect of Area Relationship in Dissimilar Metal Contacts .....3-5	3-5	3-20	Aluminum Surface Corrosion Products .....3-14	3-14
3-6	Galvanic Corrosion of Magnesium Adjacent to a Steel Fastener .....3-6	3-6	3-21	Cadmium Plated Surface Conditions .....3-14	3-14
3-7	Pitting of an Aluminum Angle Assembly .....3-6	3-6	3-22	Failed Chromium Plating .....3-15	3-15
3-8	Cross-section of Corrosion Pits .....3-7	3-7	4-1	Electronic Shelter: Installed Wood Cabinetry .....4-1	4-1
3-9	Cross-section of 7075-T6 Aluminum Alloy .....3-7	3-7	5-1	Tripod Storage Case .....5-3	5-3
3-10	Grain Structure of a Corroding Aluminum Surface .....3-8	3-8	5-2	Corroded Tripod Part .....5-3	5-3
3-11	Intergranular Corrosion of a 7075-T6 Aluminum Alloy Adjacent to Steel Fastener .....3-8	3-8	5-3	Corroded Tripod .....5-4	5-4
3-12	Example of Exfoliation .....3-9	3-9	5-4	Method 50 Label .....5-7	5-7
3-13	Another Example of Exfoliation .....3-9	3-9	5-5	Placement of Desiccant in Electronic Area .....5-7	5-7
3-14	Concentration Cell Corrosion .....3-10	3-10	5-6	Floated Item .....5-8	5-8
3-15	Filiform Corrosion Found Under a Paint Coating on a Magnesium Alloy Panel .....3-10	3-10	5-7	Floated Pack .....5-8	5-8
			5-8	Shock Isolators .....5-9	5-9
			5-9	Examples of Fiberboard Die-Cuts, Open End Cell, Tray and Pads .....5-11	5-11

## LIST OF ILLUSTRATIONS - CONTINUED

Number	Title	Page	Number	Title	Page
5-10	Application of Fiberboard Die-Cuts, Open End Cell, Tray and Pads .....	5-12	10-15	EMI Bonding Washers for Electronics .....	10-16
5-11	Polyurethane Foam.....	5-13	10-16	Dissipation of Static Charge.....	10-17
7-1	Corroded Hardware .....	7-1	11-1	3M Co. Scotch-Brite™ Flap Brush and Mandrel .....	11-7
8-1	ANMST-TIV Corroded Exterior Plugs.....	8-1	11-2	Abrasive Flap Wheels with Spindle Mount .....	11-8
9-1	Visual Evidence of Corrosion .....	9-2	12-1	Pneumatic Sealant Gun .....	12-13
10-1	Galvanic Corrosion Adjacent To Steel Fasteners.....	10-1	12-2	Sealant Application Nozzles .....	12-14
10-2	Corrosion Around Fasteners .....	10-2	12-3	Countersink Application Nozzles .....	12-15
10-3	Typical Methods of Sealing Fasteners .....	10-2	12-4	Rivet Application Nozzles - Upper/Lower .....	12-16
10-4	Faying Surface Sealing .....	10-3	12-5	Sealant and Adhesive Smoothing Tools .....	12-17
10-5	Typical Fillet Seal .....	10-4	12-6	Sealant Injection Guns .....	12-18
10-6	Spot Weld Corrosion.....	10-4	12-7	Injection Style Semkit® .....	12-21
10-7	Spot Welded Skin Corrosion Mechanism. ....	10-5	12-8	Non-Metallic Spatula .....	12-27
10-8	Electronic Shelter Door.....	10-7	12-9	Faying Surface Sealing .....	12-31
10-9	Steel Control Cables.....	10-8	12-10	Typical Fillet Seal .....	12-33
10-10	Corroded Battery Compartment.....	10-9	12-11	Typical Injection Seal .....	12-33
10-11	Bonding Cable Between Frame and Door .....	10-11	12-12	Typical Methods of Sealing Fasteners .....	12-34
10-12	ANTPS-75 Antenna Radar Surface .....	10-11	12-13	Typical Lap Skin Sealing .....	12-37
10-13	Corrosion Undercarriage of Shelter .....	10-13	12-14	Sealing Procedures for Typical Fitting .....	12-38
10-14	Magnesium Corrosion Products.....	10-16	12-15	Sealing of Access Doors .....	12-39

## LIST OF TABLES

Number	Title	Page	Number	Title	Page
3-1	Corrosion of Metals - Type of Attack and Appearance of Corrosion Products .....	3-15	8-6	Recommended Cleaning Processes for Electronic Equipment.....	8-24
7-1	Cleaning of Specific Areas and Components.....	7-3	8-7	Cleaning and Drying Problems and Solutions ....	8-28
7-2	Common Military Greases and Their Uses .....	7-15	8-8	Preservative Compounds for Electronic Equipment .....	8-32
7-3	Time Limitations for CPCs .....	7-18	11-1	Recommended Powered Abrasives for Corrosion Removal .....	11-3
7-4	Corrosion Preventive Compounds .....	7-21	11-2	Recommended Non-Powered Abrasives for Corrosion Removal .....	11-4
7-5	Preservation of Specific Areas and Components.....	7-23	11-3	Typical Chemical Corrosion Removal Procedures for Aluminum Alloy Parts and Assemblies .....	11-12
8-1	Effects of Corrosion on Electronic Equipment .....	8-4	11-4	Typical Chemical Corrosion Removal Procedures for Magnesium Alloys.....	11-14
8-2	Materials, Their Electronic Applications, and Corrosion Symptoms .....	8-5	11-5	Typical Chemical Corrosion Removal Procedures for Stainless Steel (CRES) and Nickel Based Alloys.....	11-17
8-3	Deterioration of Non-Metallic Materials .....	8-6			
8-4	Electronic Cleaning and Corrosion Removal Consumable Materials.....	8-7			
8-5	Accessories of Electronic Cleaning and Corrosion Control.....	8-20			

TO 1-1-700

**LIST OF TABLES - CONTINUED**

<b>Number</b>	<b>Title</b>	<b>Page</b>	<b>Number</b>	<b>Title</b>	<b>Page</b>
11-6	Typical Chemical Corrosion Removal Procedures for Plated and Phosphate Surfaces .....	11-21	12-1	Sealing Compounds .....	12-2
			12-2	Time Requirements for Sealants When Used at 75 °F (24 °C) & 50% RH .....	12-22

## FOREWORD

### 1. PURPOSE.

The purpose of this manual is to provide information on materials and procedures for the prevention and control and repair of corrosion damage to ground electronics equipment and associated structures, shelters, vans, and containers. Supervisory and maintenance personnel shall use this manual as an instruction for all corrosion control and maintenance efforts. Contractors who maintain and repair corrosion on ground electronics equipment and associated structures, shelters, vans, and containers shall also use this manual.

**1.1 Usage.** Use this manual in conjunction with and in support of the system specific ground electronics equipment and/or associated structure, shelter, van, or container technical orders (TOs) as well as general series TOs 1-1-8, 1-1-689, and 1-1-691. In case of a conflict between this manual and a system specific ground electronics equipment and/or associated structure, shelter, van, or container manual, the system specific manual shall take precedence over this manual. Paragraph 5 of this foreword lists related technical publications used by personnel involved in cleaning, corrosion prevention and control, and painting operations.

### 2. SCOPE.

The material in this manual provides basic cleaning, corrosion prevention and control, and corrective maintenance information for use by organizational, intermediate, and depot levels of maintenance. This manual consists of a foreword, a safety summary, and twelve chapters.

**2.1 Foreword.** The Foreword explains the purpose of this manual, defines the responsibility for changing this manual, and presents the scope and outlay of the manual.

**2.2 Safety Summary.** The Safety Summary provides general safety precautions personnel shall use during all phases of maintenance operations.

**2.3 Chapter 1, Introduction.** This chapter explains the appropriate usage of this manual.

**2.4 Chapter 2, General Requirements.** This chapter outlines specification numbers, material substitutions, nonspecific general requirements, and specific general requirements for corrosion prevention and control and repair of Ground Communication, Electronics, and Meteorological (C-E-M) Equipment and its protective shelters, vans, and radomes.

**2.5 Chapter 3, Corrosion Theory.** This chapter explains what corrosion is, why it occurs, the various forms it can take, and how to recognize it.

**2.6 Chapter 4, Composite and Non-Metallic Material Degradation and Repair.** The information contained in this chapter is intended to provide guidance and references for maintenance personnel to test, inspect, and/or repair damaged/degraded non-metallic materials or components used in the construction of ground-based C-E-M equipment and its protective shelters, vans, and radomes.

**2.7 Chapter 5, Packaging (Storage and Shipping).** This chapter is intended for use by depot and field level maintenance personnel as a guide for proper corrosion prevention and control of Ground Communications, Electronics, and Meteorological Equipment (C-E-M) during storage and shipment.

**2.8 Chapter 6, Moisture and Fungus Proofing.** This chapter provides moisture and fungus-proofing requirements to enable inspecting personnel to determine quality and acceptability of repaired equipment.

**2.9 Chapter 7, Preventative Maintenance and Refinishing on Structural Components.** This chapter is intended for use by depot and field level maintenance personnel for preventive maintenance, preservation methods and refinishing using approved materials and processes.

**2.10 Chapter 8, Preventative Maintenance on Electronic Components.** This chapter outlines corrosion inspection, removal, repair and protection for electronic components and assemblies.

**2.11 Chapter 9, Inspection.** This chapter describes the basic visual and non-destructive inspection (NDI) procedures for detecting corrosion as well as some of the signs of corrosion damage.

**2.12 Chapter 10, Corrosion Prone Areas.** This chapter describes corrosion prone areas that should be cleaned, inspected and treated more frequently than less corrosion prone areas.

**2.13 Chapter 11, Corrosion Removal.** This chapter covers procedures for corrosion removal and surface treatment.

**2.14 Chapter 12, Sealants.** This chapter covers sealing compounds and procedures for their application.



## TO 1-1-700

3. ABBREVIATIONS AND ACRONYMS.

This manual contains standard and non-standard abbreviations. The standard abbreviations are in accordance with ASME Y14.38.

Abbreviation	Definition
AFCPCO	Air Force Corrosion Prevention and Control Office
AFFF	Aqueous Film Forming Foam
AISI	American Iron and Steel Institute
BOD	Biological Oxygen Demand
CaCO <sub>3</sub>	Calcium Carbonate
CBR	Chemical, Biological, Radiological
CFM	Cubic Feet per Minute
CPC	Corrosion Preventive Compounds
CRES	Corrosion Resistant Steels
CWR	Clear Water Rinse
°C	Degrees Celsius
°F	Degrees Fahrenheit
DI	Deionized
DTIC	Defense Technical Information Center
EA	Each
EPA	Environmental Protection Agency
EPTFE	Expanded Polytetrafluoroethylene
ft	Foot/Feet
FIP	Form-In-Place
HAP	Hazardous Air Pollutants
IAW	In Accordance With
ID	Inside Diameter
in	Inch/Inches
KSI	Kilograms per Square Inch
LOX	Liquid Oxygen
MEK	Methyl Ethyl Ketone
mg/L	Milligrams Per Liter
mm Hg	Millimeters of Mercury
MOS	Maximum Operating Speed
MSDS	Material Safety Data Sheet
NDI	Non-Destructive Inspection
NRA	Nuclear Regulatory Agency
NSN	National Stock Number
OD	Outside Diameter
ODC	Ozone Depleting Compounds
ODS	Ozone Depleting Substances
%	Percent
pH	Hydrogen Ion Concentration
PMF	Pre-Mixed and Frozen
PPE	Personal Protective Equipment
ppm	Parts Per Million
QPL	Qualified Products List
RH	Relative Humidity
RTU	Ready-To-Use
SE	Support Equipment
SPD	System Program Director

Abbreviation	Definition
SPM	System Program Manager
TDS	Total Dissolved Solids
TNP	Touch-N-Prep™
TO	Technical Order
TPH	Total Petroleum Hydrocarbons
TSS	Total Suspended Solids

4. RESPONSIBILITY FOR CHANGES TO THIS MANUAL.

This manual is maintained for technical content by the Air Force Corrosion Prevention and Control Office (AFCPCO), AFRL/RXSSR, 325 Richard Ray Blvd., Robins AFB, GA 31098-1639, Tel: (478) 926-3284 (DSN 468-3284), Fax: (478) 926-6619 (DSN 468-6619), email: [afcorr@robins.af.mil](mailto:afcorr@robins.af.mil); and for administration by 406 SCMS/GUHA, 460 Richard Ray Blvd. Ste 200, Robins AFB, GA 31098-1813, email: [584msug.gbmudeafto22@robins.af.mil](mailto:584msug.gbmudeafto22@robins.af.mil).

4.1 Recommended Changes, Corrections, or Deletions. Recommendations for improvements to this technical order will be submitted in accordance with TO 00-5-1 through JCALS or on AFTO Form 22, Technical Order Improvement Report and Reply, via email to [542msug.gbmudeafto22@robins.af.mil](mailto:542msug.gbmudeafto22@robins.af.mil) or to the Technical Order Management Agency (TOMA) at 584 CBSS/GBHDE, Robins AFB, GA 31098.

5. RELATED PUBLICATIONS.

List of Related Publications	
Number	Title
DODI 6050.05	DoD Hazard Communication (HAZCOM) Program
AFI 21-105	Air and Space Equipment Structural Maintenance
AFI 21-116	Maintenance Management of Communications - Electronics
AFI 32-1067	Water Systems
AFI 32-7042	Solid and Hazardous Waste Compliance
AFI 32-7080	Pollution Prevention Program
AFI 40-201	Managing Radioactive Materials in the US Air Force
AFMAN 23-110, Vol. 7, Pt 3	The Air Force Shelf-Life Program
AFOSH STD 91-25	Confined Spaces
AFOSH STD 91-66	General Industrial Operations
AFOSH STD 91-501	Air Force Consolidated Occupational Safety Standard
AFPAM(I) 24-237	Packaging of Material - Preservation



## List of Related Publications - Continued

## List of Related Publications - Continued

Number	Title	Number	Title
MIL-E-17555	Electronic and Electrical Equipment, Accessories, and Provisioned Items (Repair Parts), Packaging of	TO 00-85-38	Preparation for Shipment of Ground Communications, Electronic, Meteorological and Navigational Aids in Vans or Shelters
MIL-DTL-14072	Finishes for Ground-Based Electronic Equipment	TO 00-110A-1	Guidelines for Identification and Handling of Aircraft and Materiel Contaminated with Radioactive Debris (Fallout)
MIL-HDBK-263	Electrostatic Discharge Control Handbook for Protection of Electrical and Electronic Parts, Assemblies and Equipment (Excluding Electrically Initiated Explosive Devices) (Metric)	TO 1-1-8	Application and Removal of Organic Coatings, Aerospace and Non-Aerospace Equipment
MIL-HDBK-304	Package Cushioning Design	TO 1-1-689-1	Cleaning and Corrosion Control - Corrosion Programs and Corrosion Theory (Vol I)
MIL-HDBK-454	General Guidelines for Electronic Equipment	TO 1-1-689-3	Cleaning and Corrosion Control - Avionics and Electronics (Vol III)
MIL-HDBK-729	Corrosion and Corrosion Prevention - Metals	TO 1-1-689-5	Cleaning and Corrosion Control - Consumable Materials and Equipment for Avionics (Vol V)
MIL-HDBK-773	Electrostatic Discharge Protective Packaging	TO 1-1-690	General Advanced Composite Repair Processes Manual
MIL-STD-129	Military Markings for Shipment and Storage	TO 1-1-691	Cleaning and Corrosion Prevention and Control, Aerospace and Non-Aerospace Equipment
MIL-STD-1686	Electrostatic Discharge Control Handbook for Protection of Electrical and Electronic Parts, Assemblies and Equipment (Excluding Electrically Initiated Explosive Devices)	TO 1-1A-1	Engineering Handbook Series for Aircraft Repair-General Manual for Structural Repair (ARINC)
MIL-STD-8651	Installation of Identification and Modification of Plates (for Aircraft)	TO 1-1A-8	Engineering Manual Series for Aircraft and Missiles Repair - Structural Hardware
MIL-STD-2073-1	DoD Standard Practice for Military Packaging	TO 1-1A-9	Engineering Series for Aircraft Repair, Aerospace Metals - General Data and Usage Factors
TO 00-5-1	AF Technical Order System	TO 1-1A-12	Fabrication, Maintenance, and Repair of Transparent Plastics
TO 00-5-15	Air Force Time Compliance Technical Order Process	TO 1-1A-14	Installation Practices for Aircraft Electric and Electronic Wiring
TO 00-20-1	Aerospace Equipment Maintenance Inspection, Documentation, Policies, and Procedures	TO 1-1A-15	General Maintenance Instructions for Support Equipment (SE)
TO 00-20-2	Maintenance Data Documentation	TO 31-1-69	Maintenance and Reconditioning of Radomes for Ground Communications-Electronic Equipment
TO 00-20-3	Maintenance Processing of Reparable Property and Repair Cycle Asset Control System	TO 31-1-75	Maintenance Engineering Standard, General Maintenance Practices
TO 00-20-14	AF Metrology and Calibration Program	TO 31-1-221	Field Instructions for Painting and Preserving Electronics Command Equipment
TO 00-25-107	Maintenance Assistance	TO 31-1-233	Field Instructions for Painting and Preserving Communications-Electronics Equipment
TO 00-25-108	Communications-Electronics (C-E) Depot Support	TO 32-1-101	Use and Care of Hand Tools and Measuring Tools
TO 00-25-234	General Shop Practice Requirements for the Repair, Maintenance, and Test of Electrical Equipment	TO 33B-1-1	Non-destructive Inspection Methods, Basic Theory
TO 00-35D-2	Electronic Set Inventory Checklist for Ground Communications-Electronic (C-E) Equipment		
TO 00-35D-54	USAF Materiel Deficiency Reporting and Investigating System		

**TO 1-1-700**

## List of Related Publications - Continued

Number	Title
TO 34-1-3	Inspection and Maintenance of Machinery and Shop Equipment
TO 35-1-3	Corrosion Prevention and Control, Cleaning, Painting, and Marking of USAF Support Equipment (SE)
TO 35-1-4	Processing and Inspection of Support Equipment for Storage and Shipment
TO 35E4-1-162	Field and Depot Maintenance Repair Instruction - Tactical Shelters Foam-Beam-Honeycomb
TO 35E4-192-2	Maintenance Instructions (Organizational and Intermediate Levels) Ground Support Equipment Cleaning and Corrosion Control AN/MSM-107

## List of Related Publications - Continued

Number	Title
TO 36-1-161	Color, Marking, and Camouflage Painting of Military Vehicles, Construction Equipment and Materials Handling Equipment
TO 36-1-191	Technical and Managerial Reference for Motor Vehicle Maintenance
TO 42A3-1-2	General Use of Cements, Sealants, and Coatings
TO 42B-1-6	Corrosion Preventive Lubricants and Anti-Seize Compounds
TO 42C2-1-7	Process Instruction - Metal Treatment of Electrode Position of Metals and Metal Surface Treatments to Meet AF Maintenance Requirements

## SAFETY SUMMARY

### 1. GENERAL SAFETY INSTRUCTIONS.

This manual describes physical and chemical processes which may cause injury or death to personnel or damage to equipment if not properly followed. This safety summary includes general safety precautions and instructions that must be understood and applied during equipment operation and maintenance to ensure personnel safety and protection of equipment. Prior to performing any task, the WARNINGS, CAUTIONS, and NOTES included in that task shall be reviewed and understood.

### 2. WARNINGS, CAUTIONS, AND NOTES.

**WARNINGS** and **CAUTIONS** are used in this manual to highlight operating or maintenance procedures, practices, conditions, or statements which are considered for the protection of personnel (**WARNING**) or equipment (**CAUTION**). **NOTES** are used in this manual to highlight operating or maintenance procedures, practices, conditions, or statements which are not essential to the protection of personnel or equipment, but are added to enhance the understanding and/or efficiency of a process. The headings used and their definitions are as follows:

#### WARNING

Highlights an essential operating or maintenance procedure, practice, condition, or statement, etc. which if not strictly observed could result in injury to, death of, or long term health problems for personnel.

#### CAUTION

Highlights an essential operating or maintenance procedure, practice, condition, or statement, etc. which if not strictly observed could result in damage to or destruction of equipment, and/or loss of mission effectiveness.

#### NOTE

Highlights an essential operating or maintenance procedure, practice, condition, or statement that enhances the understanding and/or efficiency of a process.

### 3. HAZARDOUS MATERIALS WARNINGS.

Hazardous Materials Warnings are provided through use of Hazard Symbols listed below. Consult the HAZARDOUS MATERIALS DESCRIPTION below or Material Safety Data

Sheets (MSDS) Occupation Safety and Health Administration (OSHA) Form 20 or equivalent for specific information on hazards, effects, and protective equipment requirements. If you do not have an MSDS for the material involved, contact your supervisor, or the base Safety or Bioenvironmental Engineering Offices.

3.1 Hazardous Materials Icons. The following icons are used throughout Air Force technical manuals to indicate the use of hazardous materials:



The abstract symbol bug shows that a material may contain bacteria or viruses that present a danger to your life or health.



The symbol of drops of liquid onto a hand shows that the material will cause burns or irritation to human skin or tissue.



The rapidly expanding symbol shows that the material may explode if subjected to high temperatures, sources of ignition or high pressure.



The symbol of a person wearing goggles shows that the material will injure your eyes.



The symbol of a flame shows that the material can ignite and cause burns.



The symbol of a human drinking shows that a material is poisonous or is a danger to life if ingested.



The symbol of flames over circle shows that the material has stability and reactivity properties.



The symbol of a human figure in a cloud shows that vapors of a material present a danger to life or health.



The symbol of a skull and crossbones shows that the material is poisonous or is a danger to life.

3.2 Hazardous Materials Description. The following detailed HAZMAT warnings pertain to materials or substances used in connection with procedures called out or described in this technical manual. Use these advisory warnings and their associated precautions in conjunction with the current MSDS for each material or substance. If there is a conflict between this safety summary and the MSDS, the MSDS takes precedence.

## TO 1-1-700

**A-A-3007, THINNER, PHENOLFORMALDEHYDE AND MEDIUM OIL AND STYRENATED ALKYD PAINTS AND VARNISHES** 1

A-A-3007, Thinner, is extremely flammable and a skin, eye and respiratory tract irritant. Use only in a well ventilated area. Impervious gloves, chemical goggles and impervious footwear are required. Do not take internally. Avoid contact with skin and eyes. Avoid breathing vapor and/or mist. Isolate from oxidizers, heat, sparks, electric equipment and open flame. Do not apply to hot surfaces without taking special precautions.

**A-A-55827, CHROMIUM TRIOXIDE** 2

A-A-55827, Chromium Trioxide, is highly toxic to the eyes, skin and respiratory tract. Chemical splash proof goggles and/or face shield, chemical resistant rubber gloves and apron are required. Good general ventilation is usually adequate. Do not inhale dust. Reacts vigorously or violently with a range of organic materials.

**A-A-55828 (O-S-809), SULFURIC ACID SOLUTIONS** 3

A-A-55828 (O-S-809), Sulfuric Acid Solutions, are toxic to the skin, eyes, and respiratory tract. Use only in well ventilated areas. Chemical, splash proof goggles and/or face shields and chemical resistant rubber gloves and aprons are required. Highly reactive. Prevent accidental contact with water. Never add water to corrosive. Always add corrosives to water. Store in cool, dry, well ventilated location.

**A-A-59105 (O-N-350), NITRIC ACID** 4

A-A-59105 (O-N-350), Nitric Acid, is highly toxic and a strong oxidizer. Do not get on skin, eyes, or clothing. Do not breathe vapors or mist. Use only in well ventilated areas. Wash hands thoroughly after handling. Never pour water into acid, as excessive heat will be generated. Always pour the acid into the water. Do not store near combustible materials.

**A-A-59199, CLEANING COMPOUND, OPTICAL LENS** 5

A-A-59199, Optical Lens Cleaning Compound, is flammable and a skin, eye and respiratory tract irritant. Ingestion can cause blindness and death. Use only in a well ventilated area. Neoprene, nitrile or rubber gloves, safety goggles and protective apron are required. Wash thoroughly after handling and before eating, drinking or smoking. Store in a clean, cool well ventilated area away from ignition sources.

**A-A-59260 (MIL-C-14460, TYPE I), CORROSION REMOVING COMPOUND** 6

A-A-59260 (MIL-C-14460, Type I), Corrosion/Rust Removing Compound, is a sodium hydroxide solution and therefore, highly alkaline. It is toxic to skin, eyes and respiratory tract. Chemical splash proof goggles and/or face shields and chemical resistant rubber gloves and aprons are required. Heated dip tanks shall be properly ventilated, and ventilation shall be evaluated by the Bioenvironmental Engineer prior to their initial use. When preparing/mixing this highly alkaline solution, never pour water onto the sodium hydroxide granules or flakes; this will generate an excessive amount of heat. Always pour the sodium hydroxide granules/flakes into the water.

**A-A-59282, ACID, BORIC** 7

A-A-59282, Boric Acid, is a skin, eye and respiratory tract irritant. Avoid contact with skin and eyes. Do not breathe dust or take internally. Dust mask, protective gloves, and splash proof or dust resistant goggles are required. Wash thoroughly after handling. Use only in a well ventilated area. Keep away from heat and open flames.

**AMS-G-4343, GREASE, AIRCRAFT** 8

AMS-G-4343, Aircraft Grease, is a skin and eye irritant. Do not take internally. Avoid skin and eye contact. Wash hands after each use. Use only in a well ventilated area. Rubber or plastic gloves and safety glasses are recommended. Store in a clean, cool well ventilated area away from ignition sources.



## AMS-G-6032, GREASE, PLUG VALVE

9

AMS-G-6032, Plug Valve Grease, is an eye irritant. Wash hands after use. Avoid contact with eyes. Use safety glasses as a minimum. Do not heat to above 300 °F/149 °C to prevent formulation of toxic vapors.



## AMS-S-83318, SEALING COMPOUND, LOW TEMPERATURE CURING

10

AMS-S-83318, Low Temperature Curing Sealing Compound, is a skin, eye and respiratory tract irritant. Avoid repeated or prolonged contact with the skin. Use in well ventilated areas only. Nitrile or rubber gloves and chemical resistant goggles are required. To prevent ingestion, always wash your hands before eating or smoking. Store in cool, dry, well ventilated area away from heat, ignition sources and direct sunlight.



## ASTM D 329 (PART NO. O-A-51), ACETONE

11

ASTM D 329 (part No. O-A-51), Acetone, is a flammable low order oral toxin and is a skin, eye and respiratory tract irritant. Do not take internally. Use only in a well ventilated area. Rubber, vinyl or other imperious gloves and splash proof goggles are required. Keep away from heat and open flames. Store in a clean, cool well ventilated area.



## ASTM D 3955 (MIL-V-173), VANISH, ELECTRICAL INSULATING

12

ASTM D 3955 (MIL-V-173), Electrical Insulating Vanish, is a skin, eye and respiratory tract irritant. Do not take internally. Rubber gloves, safety goggles, coverall or long sleeves are required. Wash hands with soap and water after handling. Use only in a well ventilated area. Keep away from heat and open flames. Store in a clean, cool well ventilated area.



## ASTM D 928, SODIUM BICARBONATE

13

ASTM D 928, Sodium Bicarbonate, is an eye irritant. Avoid contact with eyes. Safety glasses/goggles are required. Store in a clean, cool well ventilated area.



## DIHYDROXYDICHLORODIPHENYL METHANE

14

Dihydroxydichlorodiphenyl methane is an eye, skin, and respiratory tract irritant. Not to be swallowed. Moderately toxic. Use only in a well ventilated area. Chemical gloves and splash proof safety goggles are required. Keep away from heat and open flames. Store in a clean, cool well ventilated area away from ignition sources.



## DOD-L-25681, LUBRICANT, MOLYBDENUM DISULFIDE SILICONE

15

DOD-L-25681, Molybdenum Disulfide Silicone Lubricant, is an eye, skin, and respiratory tract irritant. Avoid breathing vapors, and skin and eye contact. Rubber gloves and safety goggles are required. Wash hands thoroughly after handling. Use only in well ventilated areas.



## DOD-P-15328, PRIMER, PRETREATMENT (WASH) FOR METALS

16

DOD-P-15328, Pretreatment (Wash) Primer, is flammable and a skin, eye, and respiratory tract irritant. Avoid breathing vapors. Use only in well ventilated areas. Rubber gloves and safety glasses with side shields are required. Wear face shield when spraying. Avoid excessive heat and sources of ignition.

## TO 1-1-700



## MIL-A-24641, ACID, HYDROFLUORIC

17

MIL-A-24641, Hydrofluoric Acid, is highly toxic if inhaled in high concentrations. Ingestion is harmful/fatal. Do not get on skin or in eyes. Do not breathe vapors or mists. Use only in well ventilated area. Rubber gloves, safety goggles with face shield, impervious boots, apron, and coveralls are required. Observe good personal hygiene practices and do not wear contaminated clothing or footwear. Never pour water into acid, as excessive heat will be generated. Always pour the acid into the water.



## MIL-A-46106, ADHESIVE/SEALANT, SILICONE RTV, CORROSIVE

18

MIL-A-46106, Corrosive Silicone RTV Adhesive/Sealant, is flammable and a skin and eye irritant. Avoid contact with skin and eyes. Use in well ventilated areas and avoid prolonged breathing of vapors. Do not take internally. Avoid contact with oxidizing materials. Store below 90 °F. Wash hands before eating and at end of work shift.



## MIL-A-46146, ADHESIVE/SEALANT, SILICONE RTV, NON-CORROSIVE, GROUP I/II/III, TYPE I OR GROUP I, TYPE II

19

MIL-A-46146, Non-Corrosive Silicone RTV Adhesive/Sealant, is flammable and a skin and eye irritant. Avoid contact with skin and eyes. Use in well ventilated areas and avoid prolonged breathing of vapors. Safety goggles required. Avoid contact with oxidizing materials. Store below 90 °F. Wash hands before eating and at end of work shift.



## MIL-C-10578, COMPOUND, CORROSION REMOVING AND METAL CONDITIONING

20

MIL-C-10578, Corrosion Removing Compound, is a skin, eye and respiratory tract irritant. Do not get on skin, in eyes or on clothing. Do not breathe vapors or mists. Use only in a well ventilated area. Protective gloves and safety goggles are required. Keep away from heat and open flames. Avoid strong alkaline materials. When mixing, always add the phosphoric acid corrosion remover to the water. Do not add the water to the acid, since this causes excessive heat to be generated.



## MIL-C-8514, PRIMER, PRETREATMENT (WASH) FOR METALS

21

MIL-C-8514, Pretreatment (Wash) Primer, is flammable and a skin, eye, and respiratory tract irritant. Avoid breathing vapors. Use only in well ventilated areas. Rubber gloves and safety glasses with side shields are required. Wear face shield when spraying. Do not store above 120 °F. Keep away from heat, sparks and flame.



## MIL-D-16791, DETERGENT, NON-IONIC

22

MIL-D-16791, Non-Ionic Detergent, Type I, is an eye irritant. Avoid contact with eyes. Chemical resistant goggles are required. Store away from heat sources. Avoid contact with strong oxidizing or reducing agents. Material is corrosive to copper and brass on long storage.



## MIL-DTL-81706 (ALODINE), COATING, CHEMICAL CONVERSION

23

MIL-DTL-81706 (Alodine) Chemical Corrosion Coating, contains carcinogenic chromates and is an eye, skin, and respiratory tract irritant. May be fatal if swallowed. For mist conditions an approved respirator is required. Rubber gloves, rubber boots, chemical resistant apron, coveralls, and face shield or goggles are required. Use only in a well ventilated area. Keep away from heat, open flames and other chemicals.





MIL-DTL-64159, COATING, POLYURETHANE, CHEMICAL RESISTANT, WATERBORNE 24

MIL-DTL-64159, Chemical Resistant Polyurethane Coating, is a skin, eye and respiratory tract irritant. Use only in a well ventilated area. An approved respirator, protective gloves, and safety goggles are required. Wash hands after each use. Keep away from heat and open flames. Store in a clean, cool well ventilated area.



MIL-DTL-85054, COMPOUND, CORROSION PREVENTIVE 25

MIL-DTL-85054, Corrosion Preventive Compound, is a skin, eye and respiratory tract irritant. Use only in a well ventilated area. Avoid breathing vapors. Protective gloves and safety goggles are required. Do not take internally. Wash thoroughly after use and before eating, drinking or smoking. Keep away from heat and open flames.



MIL-G-21164, GREASE, MOLYBDENUM DISULFIDE 26

MIL-G-21164, Molybdenum Disulfide Grease, is toxic. Avoid contact with skin and eyes. Use only in ventilated areas. Oil resistant gloves, safety goggles and protective clothing to minimize skin contact are required. Wash hands thoroughly after handling. Keep away from all sources of ignition, such as sparks and flames. Avoid strong oxidizing agents.



MIL-G-25013, GREASE, BALL AND ROLLER BEARING 27

MIL-G-25013, Ball and Roller Bearing Grease, is a skin, and eye irritant. Minimize skin and eye contact. Impervious gloves and safety glasses/goggles are required. Wash hands thoroughly after each use. Use only in a well ventilated area. Keep away from heat and open flames.



MIL-G-25537, GREASE, AIRCRAFT, OSCILLATING BEARING 28

MIL-G-25537, Oscillating Bearing Grease, is a skin and eye irritant. Minimize skin contact. Rubber gloves and safety glasses are required. Wash with soap and water after use. Keep away from heat and open flames.



MIL-I-22110, INHIBITOR, CORROSION VOLATILE, CRYSTALLINE POWDER 29

MIL-I-22110, Crystalline Powder, is poison and may be explosive. It is an eye, skin, and respiratory tract irritant. Do not take internally. Do not inhale dust. Impervious gloves, apron and dust proof goggles are required. Use only in a well ventilated area. Store in a clean, cool well ventilated area away from ignition sources and oxidizing agents.



MIL-L-23398, LUBRICANT, SOLID FILM 30

MIL-L-23398, Solid Film Lubricant, is a skin, eye and respiratory tract irritant. Use only in a well ventilated area. Avoid skin contact. Rubber gloves and face shield/goggles are required. Wash hands after each use. Keep away from heat and open flames.



MIL-PRF-3150, LUBRICATING OIL 31

MIL-PRF-3150, Lubricating Oil, is a skin, eye, and respiratory tract irritant. Avoid skin and eye contact. Avoid breathing vapors/mist. Use only in well ventilated area. Rubber gloves and safety goggles are required. Store in cool, dry and well ventilated area.

## TO 1-1-700



MIL-L-87177, LUBRICANT, CORROSION PREVENTIVE COMPOUND, WATER DISPLACING 32

MIL-L-87177, Corrosion Preventive Compound Lubricant, is a skin, eye and respiratory tract irritant. Wear gloves and safety goggles. Use only in a well ventilated area. Wash with soap and water after handling product and before eating, drinking or smoking. Keep away from heat and open flames. Store in a clean, cool well ventilated area.



MIL-M-24041, SEALING COMPOUND 33

MIL-M-24041, Sealing Compound, is a skin, eye and respiratory tract irritant. Avoid skin and eye contact. Avoid breathing vapors/mist. Use only in well ventilated area. Rubber gloves and safety goggles are required. Store in cool, dry and well ventilated area.



MIL-P-53022, PRIMER, EPOXY, CORROSION INHIBITING, LEAD AND CHROMATE FREE 34

MIL-P-53022, Epoxy Primer, is flammable and a skin, eye and respiratory tract irritant. Can be fatal if taken internally. Use only in a well ventilated area. Use of an approved respirator is required when spraying primer. Solvent impermeable gloves and safety glasses/goggles are required. Keep away from heat and open flames.



MIL-P-53030, PRIMER, EPOXY, WATER REDUCIBLE, LEAD, CHROME FREE 35

MIL-P-53030, Epoxy Water Reducible Primer, is toxic, flammable and a skin, eye and respiratory tract irritant. Avoid prolonged breathing of vapors or mists. Avoid skin and eye contact. Do not take internally. Approved respirator, protective gloves, and splash proof goggles are required. Wash hand thoroughly after each use. Keep away from heat, sparks or flame. Avoid strong acids and oxidizing agents.



MIL-P-85891, GRAIN, ABRASIVE 36

MIL-P-85891, Abrasive Grain, is flammable and an eye, skin, and respiratory tract irritant. May be harmful if ingested. Use only in a well ventilated area. Approved respirator, rubber gloves, and safety goggles are required. Wash hands thoroughly with soap and water after each use. Keep away from heat and open flames.



MIL-PRF-16173, COMPOUND, CORROSION PREVENTIVE 37

MIL-PRF-16173, Corrosion Preventive Compound, is an eye, skin, and respiratory tract irritant. May be flammable. Protect arms and legs from chemicals. Use only in a well ventilated area. Keep away from heat and open flames. Store in a clean, cool well ventilated area.



MIL-PRF-23377, TYPE I & II, PRIMER, EPOXY CHEMICAL AND SOLVENT RESISTANT 38

MIL-PRF-23377, Epoxy Primer, is flammable. It contains carcinogenic chromate compounds. Avoid prolonged or repeated breathing of vapors. Avoid skin and eye contact. Use approved respirator when spraying. Use only in a well ventilated area. Keep away from heat and open flames. Store in a clean, cool well ventilated area.



MIL-PRF-26915, PRIMER, ZINC RICH, WATERBORNE 39

MIL-PRF-26915, Zinc Rich Waterborne Primer, is flammable and a skin, eye and respiratory tract irritant. Use only in a well ventilated area. Avoid eye and skin contact. Avoid breathing sanding dust. Approved respirator, rubber gloves and safety goggles are required. Keep away from heat and open flames.





MIL-PRF-27617, GREASE, AIRCRAFT AND INSTRUMENT, FUEL AND OXIDIZER RESISTANT 40

MIL-PRF-27617, Aircraft Grease, is a skin and eye irritant. Rubber gloves and safety goggles are required. Store in a clean, cool well ventilated area away from ignition sources.



MIL-PRF-32033, LUBRICATING OIL, GENERAL PURPOSE, PRESERVATIVE (WATER-DISPLACING, LOW TEMPERATURE) 41

MIL-PRF-32033, General Purpose Preservative (Water Displacing, Low Temperature) Lubricating Oil, is a skin, eye, and respiratory tract irritant. Avoid contact with skin or eyes. Avoid breathing vapors and mists. Store in a cool dry place away from strong oxidizing agents. Rubber gloves, and safety goggles must be worn. Respiratory protection may be required in poorly ventilated areas, especially when misting occurs.



MIL-PRF-46010, LUBRICANT, SOLID FILM, HEAT CURED 42

MIL-PRF-46010, Heat Cured Solid Film Lubricant, is a skin, eye and respiratory tract irritant. Moderately toxic if ingested. Use only in a well ventilated area. Avoid prolonged or repeated breathing of vapors/dust. Safety goggles are required. Wash hands after handling and after each use. Keep away from heat and open flames.



MIL-PRF-46147, LUBRICANT, SOLID FILM, AIR CURED 43

MIL-PRF-46147, Air Cured Solid Film Lubricant, is flammable and a skin, eye and respiratory tract irritant. Do not take internally. Use only in a well ventilated area. Avoid prolonged or repeated breathing of vapors/dust. Safety goggles are required. Wash hands thoroughly after each use. Keep away from heat and open flames.



MIL-PRF-63460, LUBRICANT, CLEANER AND PRESERVATIVE 44

MIL-PRF-63460, Cleaner and Preservative Lubricant, is a skin, eye and respiratory tract irritant. Use only in a well ventilated area. Rubber gloves and splash proof goggles are required. Keep away from heat and open flames. Avoid strong oxidizing agents.



MIL-PRF-680 AND A-A-59601, SOLVENT, DEGREASING, TYPE II AND III 45

MIL-PRF-680 and A-A-59601, Degreasing Solvent, is flammable and an eye, skin, and respiratory tract irritant. Use only in a well ventilated area. Use explosion proof equipment. Nitrile gloves, splash proof goggles and impervious clothing is required. Wash thoroughly after handling and before eating or smoking. Keep away from heat and open flames. Store in a clean, cool well ventilated area away from ignition sources and oxidizing agents.



MIL-PRF-81309, LUBRICANT, CORROSION PREVENTIVE COMPOUND 46

MIL-PRF-81309, Corrosion Preventive Compound, is toxic, flammable and a skin, eye and respiratory tract irritant. Rubber gloves and safety goggles are required. Avoid skin and eye contact. Avoid breathing vapors. Use in well ventilated area. Keep away from heat, sparks, and flame. Vapor accumulations may explode if ignited.

## TO 1-1-700



## MIL-PRF-81322, GREASE, AIRCRAFT GENERAL PURPOSE 47

MIL-PRF-81322, General Purpose Aircraft Grease, is a minor skin and eye irritant. Use only in a well ventilated area. Safety glasses and gloves are required. Wash hands thoroughly with soap and water after use. Store in a clean, cool well ventilated area away from ignition sources.



## MIL-PRF-81733, SEALING AND COATING COMPOUND, CORROSION INHIBITIVE 48

MIL-PRF-81733, Sealing and Coating Compound, is flammable and may contain chromate compounds that are carcinogens. Avoid skin and eye contact. Solvent resistant gloves and safety glasses are required. Avoid breathing vapors. Use only in well ventilated areas. Wash thoroughly after handling and before smoking or eating. Keep away from heat and open flames. Store in a clean, cool well ventilated area.



## MIL-PRF-8516, TYPE II, SEALING COMPOUND, POLYSULFIDE RUBBER 49

MIL-PRF-8516, Sealing Compound, Type II, is toxic. Avoid contact with skin and eyes. Avoid breathing vapors. Wash hands thoroughly after each use; do not smoke, eat or drink in work area. Keep away from heat and flames. Rubber gloves, safety goggles and skin protection required.



## MIL-PRF-85285, COATING, POLYURETHANE, HIGH SOLIDS 50

MIL-PRF-85285, High Solids Polyurethane Coating, is toxic and flammable. Avoid skin and eye contact. Avoid breathing vapors. Use approved respirator when mixing or spraying. Wear rubber gloves and safety goggles with shield. Do not take internally. Wash hands thoroughly after each use. Keep away from heat, sparks and flame. Do not apply to hot surfaces. Store in a well ventilated area.



## MIL-PRF-85570, CLEANING COMPOUND, AIRCRAFT 51

MIL-PRF-85570, Aircraft Cleaning Compound, is a skin and eye irritant. Avoid skin and eye contact. Use in well ventilated areas. Rubber gloves and splash proof goggles are required. Wash hands thoroughly after each use. Avoid breathing vapors. Store in cool, dry, well ventilated and low fire risk area. Avoid contact with strong acids or oxidizing agents.



## MIL-PRF-87937, CLEANING COMPOUND, AIRCRAFT 52

MIL-PRF-87937, Aircraft Cleaning Compound, is a skin, eye and respiratory tract irritant. Avoid breathing vapors. Avoid skin and eye contact. Rubber or latex gloves and safety glasses with side shields or goggles are required. Wash thoroughly after handling. Use only in well ventilated areas.



## MIL-S-85420, SEALING COMPOUND, QUICK REPAIR, LOW TEMPERATURE CURING 53

MIL-S-85420, Sealing Compound, is a skin, eye and respiratory tract irritant. Use only in well ventilated area. Impervious gloves, splash proof goggles and protective clothing are required. Avoid breathing vapor and/or mists. Wash thoroughly after handling and before eating, drinking, smoking or using restroom facilities. Store in cool, dry, well ventilated area at a temperature not to exceed +80 °F.



## O-E-760, ALCOHOL, DENATURED ETHYL 54

O-E-760, Denatured Ethyl Alcohol, is a flammable liquid and a skin, eye and respiratory tract irritant. Do not take internally. Use only in a well ventilated area. Chemical resistant gloves, splash proof goggles, chemical resistant boots and protective clothing should be worn. Store in a clean, cool well ventilated area away from ignition sources.



## O-L-164, DRESSING, LEATHER

55

O-L-164, Leather Dressing, is a skin, eye and respiratory tract irritant. Do not take internally. Use only in a well ventilated area. Chemical resistant gloves, splash proof goggles and impervious clothing are required. Store in a clean, cool well ventilated area away from ignition sources. Avoid contact with strong oxidizing agents.

SAE AMS-3276 (MIL-S-83430), SEALING COMPOUND,  
INTEGRAL FUEL TANK

59

SAE AMS-3276 (MIL-S-83430), Sealing Compound, is a skin and eye irritant. Solvent resistant gloves and safety goggles are required. Wash thoroughly after handling and before smoking or eating. Avoid ingestion. Avoid oxidizing agents, heat, sparks or open flames.

SEMCO PASA-JELL 102, CHEMICAL CORROSION  
REMOVAL FOR ALUMINUM ALLOYS

56

Semco Pasa-Jell 102 is moderately toxic and is a skin, eye, and respiratory tract irritant. Chemical or splash proof goggles and/or face shield and chemical resistant gloves and apron are required. Good ventilation is normally adequate. Do not use aluminum or any type of steel wool to apply or agitate or fire will result. Wash thoroughly after each use.

SAE AMS-1640 (MIL-C-38334), CORROSION REMOVING  
COMPOUND

60

SAE AMS-1640 (MIL-C-38334), Corrosion Removing Compound, Type I, is moderately toxic to skin, eyes, and respiratory tract. Chemical splash proof goggles and/or face shield and chemical resistant rubber gloves and aprons are required. Avoid inhaling fumes, and use only in a well ventilated area.

PR-1773, SEALING COMPOUND, LOW ADHESION,  
NON-CHROMATE CORROSION INHIBITORS

57

PR-1773, Sealing Compound, is a skin, eye and respiratory tract irritant. Use only in well ventilated area. Solvent resistant gloves and safety glasses are required. Wash thoroughly after handling.

SAE AMS-3277 (MIL-S-29574), SEALING COMPOUND,  
LOW TEMPERATURE CURING

61

SAE AMS-3277 (MIL-S-29574) Sealing Compound, is flammable and a skin, eye and respiratory tract irritant. Use only in well ventilated area. Chemical resistant gloves and safety glasses/face shield must be worn. Wear appropriate clothing to avoid prolonged skin contact. Wash hands thoroughly after handling this product and prior to eating, drinking or smoking. Store below 120 °F, in a dry area away from acids, oxidizers, open flame or other possible ignition sources.

SAE AMS-3267 (MIL-S-8784), SEALING COMPOUND,  
RUBBER, HEAT RESISTANT

58

SAE AMS-3267, Sealing Compound, is a skin, eye and respiratory tract irritant. Use only in well ventilated area. Avoid breathing vapor and/or mist. Solvent resistant gloves, and splash proof goggles and faceshield are required. Wash thoroughly after handling. Store in cool, dry, well ventilated area.

SAE AMS-S-8802, SEALING COMPOUND (POLYSUL-  
FIDE)

62

SAE AMS-S-8802, Sealing Compound (Polysulfide), is toxic and flammable. Avoid prolonged breathing of vapors and prolonged or repeated skin contact. Keep away from heat, sparks, and open flame. Use with adequate ventilation to prevent vapor buildup. Rubber gloves, safety goggles and protective skin compound or coveralls are required.

## TO 1-1-700



## SALICYLANILIDE

63

Salicylanilide is very hazardous in case of ingestion and is a skin, eye and respiratory tract irritant. Avoid breathing vapors and/or dust. Splash goggles, gloves, and dust respirator are required. Use only in a well ventilated area. Store away from extreme heat and away from strong oxidizing agents. Keep away from heat and open flames.

SEMCO PASA-JELL 101, CHEMICAL CORROSION  
REMOVAL FOR STAINLESS STEEL (CRES) AND  
NICKEL BASED ALLOYS

64

Semco Pasa-Jell 101 contains strong acids and is toxic to the skin, eyes and respiratory tract. Chemical splash proof goggles and/or face shield and chemical resistant rubber gloves and aprons are required. Avoid inhaling fumes and use only in a well ventilated area. Do not use aluminum or steel wool to agitate as a combustible reaction will occur. Wash thoroughly after each use.



## TT-I-735, ALCOHOL, ISOPROPYL

65

TT-I-735, Isopropyl Alcohol, is flammable and a skin, eye, and respiratory tract irritant. In case of ingestion seek medical attention immediately. Avoid contact with eyes, skin or clothing. Use only in a well ventilated area. Neoprene gloves, safety goggles, coveralls and boots are required. Wash thoroughly after handling. Avoid breathing vapor or mist. Do not use synthetic fiber wiping cloths due to its low flash point. Dry synthetic fiber wiping cloths will cause static charge buildup and can result in a fire. Store in a clean, cool well ventilated area away from ignition sources.



## TT-N-95, NAPHTHA, ALIPHATIC

66

TT-N-95, Aliphatic Naphtha, is flammable and a skin, eye and respiratory tract irritant. Avoid breathing vapors. Neoprene, nitrile or rubber gloves and safety goggles are required. Wash thoroughly after handling and before eating, drinking or smoking. Keep away from heat and open flames or other ignition sources.

TT-P-2760, PRIMER, POLYURETHANE, ELASTOMERIC,  
HIGH SOLIDS

67

TT-P-2760, High Solids Polyurethane Primer, is flammable and a skin, eye and respiratory tract irritant. Avoid breathing vapor and/or mist. Approved organic vapor respirator, cotton, neoprene, or rubber gloves, and splash proof goggles or face shield are required. Use of long sleeve and long leg clothing is recommended. Wash thoroughly after handling and before eating or smoking. Avoid storing near high temperatures, fire, open flames, and spark sources.



## VV-P-236, PETROLATUM

68

VV-P-236, Petrolatum, is an eye irritant and upon prolonged exposure, a skin irritant. May cause stomach/intestinal irritation upon ingestion. Avoid extreme heat and strong oxidizing agents. Wear rubber gloves and safety goggles.



## MIL-PRF-85582, PRIMER, EPOXY, WATERBORNE

69

MIL-PRF-85582, Waterborne Epoxy Primer, is flammable and a skin, eye and respiratory tract irritant. Do not take internally. Avoid contact with skin, eyes and clothing. Use only in well ventilated areas. Approved respirators, protective gloves, protective goggles or safety glasses with splash guards are required. Avoid breathing vapors or mist. Wash thoroughly after handling. Store in a clean, cool, well ventilated areas away from ignition sources.



MIL-T-81772, THINNER, POLYURETHANE 70

MIL-T-81772, Polyurethane Thinner, is flammable and a skin, eye and respiratory tract irritant. Avoid contact with eyes and skin. Do not breathe vapors. Wash hands thoroughly after handling. Use only in well ventilated area. Neoprene gloves and safety glasses with side shields are required. Store in a clean, cool well ventilated area away from ignition sources.



SAE AMS 3166, SOLVENT, WIPING 71

SAE AMS 3166, Wiping Solvent, is flammable and toxic to the skin, eyes and respiratory tract. Use only in well ventilated areas. Approved respirator, impervious gloves, rubber apron, and chemical resistant goggles are required. Store in well ventilated areas away from heat, sparks, electrical equipment and open flames.



A-A-59281, SOLVENT, CLEANING 72

A-A-59281, Cleaning Solvent, is extremely flammable. Closed containers may explode if exposed to extreme heat. Use only in well ventilated areas. Approved respirator, impervious gloves, rubber apron, and chemical resistant goggles are required. Isolate from oxidizers, chromates and peroxides. Store in well ventilated areas away from heat, sparks, electrical equipment and open flames. Vapors may ignite explosively and spread long distances. Prevent vapor buildup.



SAE AMS 3255, TAPE, SEALING, POLYTETRAFLUOROETHYLENE 73

SAE AMS 3255, Polytetrafluoroethylene Sealing Tape, is a skin, eyes and respiratory tract irritant. Keep away from eyes. Use in a well ventilated area. Wash hands thoroughly after handling.



MIL-C-43616, CLEANING COMPOUND, AIRCRAFT 74

MIL-C-43616, Aircraft Cleaning Compound, is a skin, eye and vapor irritant. Keep away from eyes and use in ventilated area. Neoprene gloves and chemical goggles are required. Wash hands thoroughly after handling. Store at temperatures of 30 - 90 °F away from sparks/flame/heat.



SAE AMS 3374, SEALANT, SILICONE 75

SAE AMS 3374, Silicone Sealant, is a mild eye and skin irritant. Avoid contact with skin and eyes. Remove contact lenses before using sealant. Wash hands after handling.



# CHAPTER 1

## INTRODUCTION

### 1.1 CORROSION CONTROL PROGRAM.

All activities responsible for maintenance of Ground Communications, Electronics, and Meteorological Equipment (C-E-M) and the shelters, vans and support equipment in/on which they are contained/mounted shall establish a corrosion prevention and control program as required by AFI 21-105. The type of program depends upon the environment to which the equipment may be exposed such as industrial gases, rain, high humidity, deicing chemicals, mud, and salt-laden air or mists if located in the vicinity of salt water. A comprehensive corrosion prevention and control program shall provide ground communications and electronics equipment maintenance work centers with personnel who are both trained in and dedicated to the prevention, early detection, reporting, and repair of corrosion damage. This type of corrosion prevention and control program prevents much of the corrosion from occurring and/or detects it in its initial stages so that early treatment will minimize costly repairs and improve the operational readiness of ground communications and electronics equipment and the shelters, vans and support equipment in/on which they are contained/mounted.

**1.1.1 Training.** All personnel performing maintenance on ground communications and electronics equipment and the shelters, vans and support equipment in/on which they are contained/mounted shall be trained in basic corrosion prevention and control skills and must be fully aware of the reasons for the corrosion prevention and control program. Without such training and understanding, more severe damage and additional problems will result.

**1.1.2 Maintenance.** An effective corrosion prevention and control program shall include thorough cleaning, inspection, preservation, and lubrication at established specified intervals according to Chapter 7 of this manual and the applicable system/equipment specific maintenance manual. Check for corrosion damage and the integrity of the protective finishes and preservative coatings during all scheduled and unscheduled maintenance. Early detection and repair limits the severity of the damage. When corrosion is found, treat the corrosion as prescribed in Chapters 7 and 8 of this manual, TOs 1-1-689-series and 1-1-691, and the applicable system/equipment specific maintenance manual using only approved materials, equipment, and techniques. Seal according to Chapter 12 of this manual, TO 1-1-691, and the applicable system/equipment specific maintenance manual. Touch-up or repaint according to TO 1-1-8 and the applicable system/equipment specific maintenance manual. All maintenance personnel shall report corrosion promptly according to established Air Force directives.

### 1.2 SAFETY.

Safety is everyone's business and concern.

**1.2.1 Responsibility of Supervisors.** Work center supervisors shall receive the following training in accordance with established Air Force directives:

- The recognition and elimination of hazards.
- Occupational safety and health.
- The safety of the individual.
- Accident investigation and reporting.
- The inspection and maintenance of personal protective equipment (PPE).

**1.2.1.1** Supervisors shall ensure that all maintenance personnel are informed of:

- Current safety procedures.
- Characteristics of materials to which they will be exposed and the existence and location of the applicable Material Safety Data Sheets (MSDS).
- Required protective clothing and personal protective equipment (PPE) to ensure safety of personnel.

**1.2.1.2** Supervisors shall also ensure that an adequate supply of safety equipment and PPE are available and in a ready-for-issue condition and personnel under their control use the appropriate safety equipment and PPE while exposed to hazardous conditions during corrosion prevention and control operations to prevent accidents, injuries, and occupational illnesses. Supervisors shall instruct personnel and make sure that they report any protective equipment and PPE that is broken, damaged, defective, or inadequate to ensure that no one uses equipment that is not in a satisfactory and serviceable condition.

**1.2.1.3** Finally, supervisors shall ensure that all their personnel comply with occupational safety and health requirements to include: medical examinations, respirator training and fit testing, and protection for eyes, ears, head, skin, and feet.

**1.2.2 Materials Handling.** Many of the materials and procedures outlined in this manual are either potentially hazardous to personnel or damaging to ground communications and elec-



**TO 1-1-700**

tronics equipment and the shelters, vans and support equipment in/on which they are contained/mounted; especially when improperly used. When using chemicals such as paint removers, cleaning compounds, conversion coatings, and solvents or mechanical tools such as sanders, grinders, and abrasive blasting equipment, follow the correct procedures, use the appropriate PPE, and use proper protection for surrounding areas on the equipment being repaired to prevent personnel injury and/or functional or structural damage to the equipment. Read the appropriate WARNINGS and CAUTIONS in this manual and the MSDSs prior to using any hazardous materials. Misuse of some materials can damage parts and/or generate corrosion which may cause catastrophic failures. Refer to DODI 6050.05, DoD Hazard Communications (HAZCOM) Program, and the appropriate Air Force directives for handling, storage, and disposal of hazardous materials. Refer to local directives and policies pertaining to hazardous waste management. When in doubt, contact the base safety office and/or the bioenvironmental engineer for assistance.

**1.3 MATERIALS.**

Consumable materials listed in TOs 1-1-689-5 and 1-1-691, Appendix A, shall be used for cleaning and corrosion preven-

tion and control. The materials and equipment listed in these appendices have been approved after extensive testing to prove their ability to perform properly and effectively without causing damage to any of the metallic or nonmetallic materials used in ground communications and electronics equipment and the shelters, vans and support equipment in/on which they are contained/mounted when used according to procedures in these manuals. Only those materials listed in these manuals shall be used for cleaning of and corrosion prevention and control on ground communications and electronics equipment and the shelters, vans and support equipment in/on which they are contained/mounted unless they are specified in and required by procedures in a system specific maintenance manual. When materials and processes considered to be an improvement over existing ones are found, information concerning these materials and processes shall be forwarded to the equipment System Program Manager (SPM) and the Air Force Corrosion Prevention and Control Office (AFCPCO), AFRL/RXSSR, for further evaluation and approval. When several materials and/or methods are listed, the preferred one is listed first with alternates following.



## CHAPTER 2

# GENERAL REQUIREMENTS

### 2.1 GENERAL.

This technical manual is intended for use by depot and field level maintenance personnel in the requirement and determination of the quality and acceptability of work performed for corrosion prevention and control and repair of Ground Communication, Electronics, and Meteorological Equipment (C-E-M) and its protective shelters, vans, and radomes. Nothing in this technical manual shall be interpreted as specifying the extent of repair or refinish except when noted defects affect the operational characteristics or tolerances of a piece of equipment. All activities involved with corrosion prevention and control and repair of C-E-M equipment or inspection and/or testing of the repaired or refurbished equipment shall use this technical manual in conjunction with TOs 1-1-8, 1-1-689-series, 1-1-691, and equipment system specific maintenance manuals as a guide for corrosion prevention and control and refinishing/touchup operations.

**2.1.1 Specification Numbers.** The primary specification number only without the revision letter suffix (e.g. MIL-PRF-23377 and not MIL-PRF-23377G, H, etc.) will be used when military, federal, and/or commercial item description (CID) specifications are listed in this manual to avoid having to update this manual every time a specification is revised. Use of materials conforming to the most current revision of a specification is implied by referencing the primary specification number without the revision letter suffix.

**2.1.2 Material Substitutions.** Manufactured items shall conform to the applicable requirements of MIL-HDBK-454 unless otherwise covered by Air Force technical data. If a material substitute conforms to this handbook, no further authorization for its use is required. If a satisfactory substitute conforming to MIL-HDBK-454 cannot be found or if in doubt as to the applicability of the substitute, forward the problem along with a proposed solution to the equipment System Program Manager (SPM) at the prime Air Logistics Center (ALC).

### 2.2 NONSPECIFIC GENERAL REQUIREMENTS.

**2.2.1 Workmanship.** This list of general nonspecific requirements establishes repair standards that determine the acceptability of repaired and/or refurbished equipment.

- Repair and/or rework components/parts in a thoroughly workman-like manner.
- Maintain dimensions within the specified tolerances in/on the equipment drawings, specifications, or system

specific technical manuals. If not specified, hold dimensions within tolerances that are according to the best manufacturing practice for the type of equipment involved.

- If special tools are required, they shall not be unserviceable, broken, or excessively worn; and mounting facilities for the tools shall be adequate.

**2.2.2 Overall Cleanliness and Cleaning.** Maintain the exterior and interior of equipment and components such that they will be free of grease, dirt, corrosion, fungus, and any other extraneous/foreign matter. Use only those cleaning processes that have no harmful or damaging effect on the equipment being cleaned. Observe all the warnings, cautions, and notes listed below as well as in other published specific cleaning procedures during all cleaning operations.



MIL-PRF-680 AND A-A-59601, SOLVENT, DEGREASING, TYPE II AND III 45



MIL-PRF-87937, CLEANING COMPOUND, AIRCRAFT 52



TT-N-95, NAPHTHA, ALIPHATIC 66



MIL-PRF-680 and A-A-59601 Dry Cleaning/Degreasing Solvents and TT-N-95 Aliphatic Naphtha shall not be used on electrical parts, and rubber jacketed cords and cables as these solvents can damage them.

- Clean exterior and interior structural areas of vans, shelters, and equipment cases with MIL-PRF-87937, Type III (undiluted) or Type IV (diluted solution) Cleaning Compounds or MIL-PRF-680 or A-A-59601, Type II or III Dry Cleaning/Degreasing Solvents or TT-N-95 Aliphatic Naphtha or other cleaners as dictated by the

## TO 1-1-700

cleaning situation, system-specific manuals, or equipment SPD involved according to methods and procedures in Chapter 7 of this manual.

- b. Clean electrical contacts per procedures in Chapter 8 of this manual.
- c. Clean electrical parts such as resistors, fixed or variable capacitors, coils, and switches with an appropriate non-metallic, soft bristle brush or a lint-free cloth only per procedures in Chapter 8 of this manual.
- d. Clean ventilation screens and filters with an appropriate vacuum cleaner to remove any accumulated dust or debris that would impede the free flow of air.

**WARNING**

Use of compressed air can create airborne particles that can enter the eyes and/or penetrate the skin and cause serious injury. Air pressure for compressed air cleaning shall be maintained at 30 PSIG or lower at the nozzle. Use of proper eye and hand protection is mandatory during compressed air cleaning operations. Control of nozzle direction to direct the air stream away from equipment interiors, other equipment and other personnel in the area is also required.

**CAUTION**

Compressed air with entrained moisture or oils can cause corrosion of and/or interfere with the electrical properties of equipment. Use only compressed air from a source with an oil/water separator installed and preferably, with an additional air dryer also. To be on the safe side, always direct the first air blast at the floor to clear any possible condensed moisture

from the compressed air line before using it for cleaning.

- e. Compressed air may be used to clean away dirt, dust, and other debris from equipment mounting areas in vans and shelters, the exterior and interior of removed equipment cases and covers, an open equipment chassis. Compressed air shall not be used to clean speaker cones, the interior of electrical meters, plates of tuning capacitors, relay contacts, plates of selenium rectifiers, transistors, and distributor wiring in high or ultra-high frequency RF amplifiers or oscillator circuits. Use a hand bellows or rubber bulb to direct air onto these components for cleaning.
- f. Lubricate all components/parts requiring lubrication according to the applicable equipment system specific technical manual (Air Force or commercial) and/or lubrication charts after cleaning operations. Parts not usually covered by lubrication requirements such as door mechanisms, hinges, latches, locks, and exposed gears and bearings shall also be lubricated at this time with an appropriate water displacing lubricant listed in Chapter 7 of this manual to prevent corrosion, squeaking, and binding.

**2.2.3 Soldering.** Soldering can be the source of many corrosion problems in electronics equipment if the process is not proper and/or the wrong materials are used. The process consists of pre-cleaning areas to remove contaminants, tinning of areas, applying flux or using a flux cored solder, heating to flow the solder, and post cleaning to remove flux residue. Unless otherwise directed in a system specific technical manual, use only the materials listed in this manual for soldering operations. Solder shall be a non-activated/non-corrosive rosin or rosin/alcohol flux cored solder conforming to ANSI-J-STD-006 and listed in the most current qualified products list (QPL) for this specification. Use the following techniques to provide good, corrosion free soldered electrical connections in ground C-E-M equipment:



TT-I-735, ALCOHOL, ISOPROPYL

65



TT-N-95, NAPHTHA, ALIPHATIC

66

**WARNING**

- Soldering can generate toxic fumes and sometimes pop solder particles into the air. Avoid breathing the fumes, and provide adequate ventilation. Eye protection is required.
- Use of compressed air can create airborne particles that can enter the eyes and/or penetrate the skin and cause serious injury. Air pressure for compressed air cleaning shall be maintained at 30 PSIG or lower at the nozzle. Use of proper eye and hand protection is mandatory during compressed air cleaning operations. Control of nozzle direction to direct the air stream away from equipment interiors, other equipment, and other personnel in the area is also required.

**CAUTION**

Do not use acid or acid salt type fluxes in soldering electrical connections as this can cause corrosion problems at these connections as well as elsewhere within electronic equipment. Acid or acid salt type fluxes can be used only for tinning and soldering of mechanical joints not associated with electrical connections; and then, only if completely neutralized and removed immediately after the soldering operation.

- Clean areas to be soldered with a lint-free cloth wet with TT-I-735, Isopropyl Alcohol, or TT-N-95, Aliphatic Naphtha, to remove any contaminants; and wipe the areas dry with a clean, lint-free cloth.
- Use SN60WRP solder for general electrical and electronic connections, SN62WRP solder for silver plated connections, and SN63WRP solder for printed wiring boards and other applications where temperature limitations are critical.

- Tin all areas of all components to be soldered properly with the appropriate solder for the type of solder connection being made.
- Position and hold fixed all components to be soldered in a joint so that after assembly the mechanical strength of the joint is not dependant on the solder. Apply the appropriate amount of heat for the type of solder being used and flow the solder to make the solder joint.
- Inspect the soldered joint to ensure that a good, neat electrical connection that feathers out to a thin edge indicating proper solder flow and wetting is made. Ensure that no sharp points, rough areas, overheated or underheated areas, crystallized areas that are indicative of a cold solder joint or rosin joint is present.



TT-I-735, ALCOHOL, ISOPROPYL

65



TT-N-95, NAPHTHA, ALIPHATIC

66

- Clean the solder joint to remove all rosin flux residue with a lint-free cloth wet with TT-I-735 isopropyl alcohol or TT-N-95 Aliphatic Naphtha; and dry the area either by wiping with a clean, lint-free cloth or by directing a blast of compressed air onto the joint.

2.2.4 Riveting. Consult TO 1-1A-8 for assistance with the determination of the type of rivet to be used for a specific application and for proper techniques of rivet installation.

MIL-PRF-81733, SEALING AND COATING COMPOUND,  
CORROSION INHIBITIVE 48

- When riveting structural joints, rivets shall be installed with the structure faying surfaces and rivet shanks wet with a MIL-PRF-81733 corrosion inhibiting sealant. Consult Chapter 12 of this manual to determine the proper type, class, and grade to be used as well as the proper mixing and application techniques.
- Rivet heads shall be properly seated and flush against the surfaces of the parts being riveted.

## TO 1-1-700

- c. Riveted joints shall be tight, and each of the joined parts shall be undamaged.
- d. Riveting shall not be used to mount components such as capacitors, transformers, resistors, reactors, etc. unless directed by an equipment system specific technical manual or specification.

**2.2.5 Welding.** Improper welding can be the cause of severe corrosion problems. Use these general precautions and techniques during welding operations to minimize in-service corrosion problems on welded components. Consult Chapter 1 of TO 31-1-75 for additional information on welding.

**WARNING**

Welding operations produce high heat, highly toxic fumes, injurious radiation, metal slag, and airborne particles. Welding goggles and/or face mask with properly tinted lenses, protective apron or jacket, and welder's boots and gloves are required. Adequate ventilation with air flow from behind the welder and toward the work piece is usually sufficient.

- a. Make sure welds are of ample size with thorough penetration and good fusion and are free of scabs, blisters, abnormal pockmarks, bruises, spatter, and any other harmful defects. This will prevent corrosion due to moisture entrapment in crevices created by incomplete and/or poor welds.
- b. Arc welding electrodes shall be a type that produces a weld having chemical and physical properties very similar to the parent metal properties. This will prevent galvanic corrosion associated with the weld due to dissimilar metal contact.



MIL-PRF-81733, SEALING AND COATING COMPOUND,  
CORROSION INHIBITIVE 48

- c. When tack/spot welds are used to permanently secure parts together, a sufficient number of welds shall be made to provide adequate joint strength and rigidity to hold the parts together, with a minimum of two welds being required. This type of welded structure is highly susceptible to crevice corrosion due to moisture intrusion between the parts by capillary action. To prevent this from happening, apply a continuous bead of MIL-PRF-81733, Type IV-12, Class 1, Grade A corrosion inhibiting sealant around the entire periphery of the fay-

ing or contacting surfaces of the parts according to procedures in Chapter 12 of this manual. Mate the parts and tack/spot weld them together while the sealant is still wet.

**2.2.6 Wiring and Cabling (Wire and Cable Runs).** Wire and cable runs should be inspected for defects such as cuts, cracks, kinks, crushed areas, abraded or deteriorated insulation that exposes the wire/cable conductors. If any of these conditions are found, the wire/cable should be replaced per the criteria in Chapter 1 of TO 31-1-75 as soon as possible to prevent moisture from contacting the conductors and causing them to corrode and/or short out. Using insulation sleeving to repair insulation defects should be avoided if at all possible because moisture can be wicked under the sleeving by capillary action, become trapped, and cause corrosion of the metal conductors. Wires and cables shall be protected from cuts and abrasion; shall not be sharply bent around corners or edges to prevent cutting and cracking of the insulation; and when passing through a hole in sheet metal with a thickness of 1/8 inch or less, shall be protected by using a suitable rubber grommet. Wire and cable runs, including hookup wiring, shall be properly supported to prevent undue stress on their conductors and the terminals to which they are attached.

**2.2.7 Grounding.** All C-E-M equipment shall be properly grounded. See Chapter 8 of this manual for further information on grounding.

### 2.3 SPECIFIC GENERAL REQUIREMENTS.

**2.3.1 Fixed Capacitors.** All fixed capacitors should be inspected for swelling; leakage or breaks in the protective covering; cracked or chipped terminal insulation bushings; or leaking gaskets, seams, or bushings. If any of these conditions are found, the capacitor should be replaced with a like item and clean up any leaked dielectric to prevent corrosion of the surrounding circuitry due to the leaked dielectric in conjunction with moisture and the internal areas of the capacitor itself due to moisture intrusion.

**2.3.2 Variable Capacitors.** Inspect the plates of variable/tunable capacitors for corrosion and determine that the tuning shaft is free moving. Remove minor/surface corrosion from the plates with A-A-58054, Type I, Class 1, Grade A (very fine) abrasive mat per procedures in Chapters 11 and 12 of this manual and Chapter 5 of TO 1-1-691. Lubricate the tunable shaft of the capacitor with MIL-L-87177, Grade B or MIL-PRF-81309, Type III avionics grade, water displacing lubricant/corrosion preventive compound (CPC) per procedures in Chapter 7 of this manual.

**2.3.3 Controls.** Inspect controls and moving parts of switches, rheostats, and potentiometers for the presence of any corrosion; smooth mechanical operation at all points with no

dead spots, binding, scraping, or excessive backlash; and for proper electrical operation with good electrical contact without any cut-outs or erratic operation. Remove minor/surface corrosion from these parts with A-A-58054, Type I, Class 1, Grade A (very fine) abrasive mat per procedures in Chapters 8 and 11 of this manual and Chapter 5 of TO 1-1-691. Lubricate the tunable shafts of these parts with MIL-L-87177, Grade B or MIL-PRF-81309, Type III avionics grade, water displacing lubricant/corrosion preventive compound (CPC) per procedures in Chapter 7 of this manual.

**2.3.4 Dials and Pointers.** Inspect dials and pointers for the presence of any corrosion; clear and complete marking with proper alignment to indicate the correct values and/or settings; secure attachment to either the equipment case or control shaft as applicable; and freedom of movement throughout their entire operational range with no binding or sticking. Remove minor/surface corrosion from these parts with A-A-58054, Type I, Class 1, Grade A (very fine) abrasive mat per procedures in Chapters 8 and 11 of this manual and Chapter 5 of TO 1-1-691. Lubricate the tunable shafts of these parts with MIL-L-87177, Grade B or MIL-PRF-81309, Type III avionics grade, water displacing lubricant/corrosion preventive compound (CPC) per procedures Chapter 7 of this manual.

**2.3.5 Frameworks, Cabinets, and Mechanical Assemblies.** Frameworks, cabinets, and assemblies will conform to the original/modified system specific specifications and be free of broken, cracked, distorted, and corroded members.

- a. Metal cases and cabinets will be free of corroded areas, cracks, deep cuts, and holes or openings (except those required by the system specific equipment specifications and/or drawings).
- b. Minor damage, such as discolored or tarnished surfaces that do not effect operational performance, slight scratches, dents, and chipped edges that can be readily smoothed out are permissible as long as the defects are properly noted in the equipment maintenance forms, and the tarnish is removed and the other defects are properly touched-up as soon as practical.
- c. Removable assemblies will fit securely in their proper places and be easily removed and reinstalled without sticking or binding due to mechanical distortion and/or corrosion.

**2.3.6 Finishes.** Finish systems are applied to C-E-M equipment and its shelters, vans, and radomes to provide corrosion protection to the equipment, and they shall be maintained in good condition. The exterior and interior of C-E-M equipment shall be completely covered with a corrosion preventive finish system consisting of plating, chemical conversion coating,

primer, paint/coating topcoat, or an appropriate combination of them as required by the original system specific specifications and drawings, the system specific maintenance manuals, and/or MIL-HDBK-454. Finish systems shall conform to the required Military or Federal Specification. Either touch-up, complete overcoat, or complete recoating is satisfactory for maintaining the finish system. Complete recoating/refinishing shall not be done solely to match the colors, shades, and glosses of the various components or to replace a wrinkle finish of an electronic system and is not required if the cost of touch-up and/or overcoat is less than 65% of the cost to completely refinish the item. Touch-up plating (brush plating) and/or complete replating shall be done per the appropriate section of TO 42C2-1-7. Application of conversion coatings shall be done per Chapter 7 of this manual. Touch-up painting/maintenance painting, overcoating, and complete repainting shall be done per procedures in Chapter 7 of this manual. The color, shade, and gloss of paint used for touch-up operations shall match the FED-STD-595 color number of the original finish system; but it should be understood that exact matching of an old finish system is very unlikely.

#### NOTE

MIL-E-4158, Wrinkle Finish, is not used for newer C-E-M equipment. If touch-up or complete refinishing of an older piece of equipment having a wrinkle finish is required, use a flat polyurethane coating that is available in the Air Force supply system and matches as close as possible the original finish system chosen from FED-STD-595.

**2.3.7 Gaskets.** Gaskets can prevent corrosion if they seal effectively or they can be the cause of corrosion if improperly mounted and/or do not seal properly.

- a. Inspect gaskets to ensure they are live/resilient and have no breaks, cracks, or chips that prevents them from providing a tight seal thus allowing moisture to enter a piece of equipment and cause corrosion. In addition, ensure that an installed gasket meets all mating edges/surfaces evenly with no high spots and look for places where the gasket does not make complete contact with the seal flanges that would allow moisture to wick between the gasket and the flange surface and cause corrosion.
- b. Replace cork or paper gaskets when they are disturbed by removal of parts from a piece of equipment. Cork and paper gaskets are notorious for absorbing moisture and causing corrosion of the metal seal plane surfaces; so if at all possible, replace them with a new closed cell rubber gasket with the approval of the equipment System Program Manager (SPM).



**TO 1-1-700**

- c. Remove and replace any gasket that shows signs of a permanent set, as this condition prevents proper sealing.

**2.3.8 Hardware.** Ensure that all hardware such as carrying handles, latches, and hinges are fastened securely in place and are finished per the equipment specifications and drawings. Ensure that all latches and hinges operate freely with no sticking or binding and that all latches snap firmly in place and hold latched parts tightly together to prevent moisture entry into a piece of equipment. Consult Chapter 10 of this manual for periodic lubrication and preservation procedures for these parts.

**2.3.9 Keys and Switches.** Inspect key and switch frames and plungers for corrosion, wear, bending, and any other distortion that would interfere with the proper functioning of the key or switch, and correct any problems found by removing the corrosion if possible, replacing the mechanically defective part, and/or properly lubricating working mechanisms with an avionics grade lubricant/preservative per Chapter 8 of this manual.

**2.3.9.1** Ensure that plungers of push button and twist type keys operate freely in the key frame but that any side thrust on the plunger will not operate spring contacts.

**2.3.9.2** Ensure that levers of lever type keys operate freely in either direction without binding and that levers return unaided from their operational position on lock combinations before traveling approximately one-half the total allowable lever travel distance when released from the operational position.

**2.3.9.3** Ensure that any cam rollers associated with keys turn freely on their bearings and that plunger springs of non-locking spring combinations press against the cam rollers with enough force to return the key lever to its normal operational position when it is released from the operational position.

**2.3.9.4** Ensure that rotary switches have a positive mechanical index at both the CONTACT and OFF positions so that the rotating shaft stops only at those positions.

**2.3.9.5** Inspect all accessible type relays for condition of contacts, arching, chatter, proper alignment, and proper operational control functions. Adjust, clean, and burnish contacts as required per procedures in Chapter 8 of this manual.

**2.3.10 Mounting of Parts.** To ensure proper equipment operation and prevent moisture entry into the faying surface area of mounted parts and subsequent corrosion problems, ensure that all parts are securely mounted and that all missing hardware and components are replaced.

**2.3.10.1** All mounting screws, nuts, bolts, rivets and welds shall be tight when checked by hand and/or with a suitable

tool. All required lock-washers and cotter pins shall be installed and tight where used on mounting screws, bolts, nuts, and linkage assemblies.

**2.3.10.2** Knurled surfaces shall not be worn smooth or severely, mechanically damaged, and threaded parts shall not have stripped or cross threaded threads.

**2.3.11 Mechanical Parts.** Ensure that mechanically operated parts, such as gears, sprockets, and claws, operate freely without binding or excessive looseness and are free of worn, bent, broken, or burred teeth. Periodic lubrication with the lubricant specified in the equipment system specific maintenance manual will ensure that these parts continue to function properly and free of corrosion.

**2.3.12 Plastic, Glass, and Ceramic Parts.** Ensure that plastic and glass parts are free of cracks, breaks, severe chipping or scratching that would impair their proper functioning, allow leakage of moisture into a piece of equipment and cause corrosion, or present a personnel hazard due to sharp edges. Finished surfaces of plastic parts shall be free of burned or melted spots and warping. Ceramic parts shall be free of surface cracks and glazing, but minor chipping is allowed as long as it does not interfere with proper functioning or impair the insulating properties of the parts. If these conditions are found, the parts shall be replaced.

**2.3.13 Rubber Parts.** Ensure that rubber parts, such as grommets, gaskets, seals, etc., are in a sufficiently live or resilient condition to allow them to function. Rubber parts that are cut, torn, crushed, permanently set, worn, or embrittled to the point they will not function properly shall be replaced. Defective gaskets and seals are of particular concern as they will allow moisture entry into equipment and cause corrosion.

**2.3.14 Resistors.** Inspect resistors for chipping and/or cracking that results in exposure of the resistive element, an illegible color codes, and an ohmic value outside the specified tolerance range. If any of these conditions exist, the resistor shall be replaced because exposure of the resistive element can lead to corrosion of the element and illegible color codes, and out of tolerance conditions can lead to improper circuit resistances; all of which can cause the equipment in which the resistors are installed to malfunction. Potentiometer type resistors shall have center arms that operate smoothly with no evidence of scratching, dead spots caused by contact corrosion, or a burned out portion that causes loss of electrical contact. Refer to Chapter 8 of this manual if any of these conditions are found.

**2.3.15 Spring Assemblies.** Inspect keys, jacks, relays, and similar types of spring assemblies to ensure they are tightly and securely assembled with spring contacts that line up so that the contact point of each falls within the boundary of the

opposing contact and are approximately straight and free of sharp bends (gradual bowing is allowed). Ensure also that insulators are not cracked or broken to the point that shorting can occur. Chipped insulator edges are allowed as long as the chipped area does not extend below the spring contact. Inspect contacts for heavy build-up of soils, tarnishing, and pitting that penetrates through the plating to the base metal. If the contact area is heavily soiled, tarnished, or has minor pitting, clean and/or remove the tarnish and minor pitting per procedures in Chapter 8 of this manual. If severe pitting is found, replace the part.

**2.3.16 Sockets and Plug-In Devices.** Inspect plug-in devices for firm seating that produces reliable electrical contact in their sockets and for sockets that are not cracked or badly chipped. If badly chipped and/or cracked sockets and/or poor electrical contact are noted, replace the plug-in device.

**2.3.16.1** Inspect sockets designed to absorb vibration for loss of resiliency through normal aging and/or over-tightening of their rubber mountings. If this condition exists, replace the plug-in device.

**2.3.16.2** Inspect all terminals and prongs for corrosion, bending, breaks, burning, and contact positioning not conforming to the connector design parameters. If any of these conditions are found, attempt to correct the conditions per procedures in Chapter 8 of this manual. Replace any connector that can not be made serviceable by those procedures.

**2.3.17 Fuses and Fuse Holders.** Ensure that fuses and fuse holders are free of corrosion, cracks, and any evidence of overheating and that indicating type fuse holders illuminate when the installed fuse is open and its associated circuit is energized. Corroded, cracked, and overheated fuses shall be replaced. Cracked fuse holders shall be replaced while corroded ones shall be treated per procedures in Chapters 8 and 11 of this manual to remove the corrosion and replaced if this is unsuccessful. When overheating is indicated, its source shall be determined and the problem corrected.

**2.3.18 Panel Lamps.** Ensure that panel indicator lamps operate per design and applicable technical data parameters. The glass jewels or lenses shall be the proper color and not cracked, broken, or discolored/darkened by heat emitted by the installed bulbs. Lenses showing any of these conditions shall be replaced. Bulbs that are burned out or have corroded bases and bulb sockets that are corroded shall also be replaced.

**2.3.19 Shock Mounts.** Ensure that shock mounts are in good condition and cushion the equipment mounted on them

properly. Shock mounts with severe corrosion and/or with other defects that impairs proper functioning shall be replaced. Shock mounts with minor to moderate corrosion that does not impair their function shall have the corrosion removed by an appropriate procedure in Chapter 11 of this manual.

**2.3.20 Safety Interlock Switches.** Ensure that all safety interlock switches on equipment doors and/or panels operate with a very positive action to make or break electrical contact with no sluggishness when the doors or panels are opened and/or closed. All slow acting and/or non-acting safety interlock switches caused by extremely dirty, corroded, or otherwise defective contacts and/or plungers shall be replaced. All manually operated safety interlock bypass switches shall function properly or they shall be replaced. CAUTION plates for these manual switches shall be in place and legible or they too shall be replaced.

**2.3.21 Vibrators.** Ensure that vibrator cans are not severely corroded or dented, show no evidence of tampering, and have straight pins with no cracks in the base. When vibrator cans have any of the above noted defects, the vibrators shall be replaced. Minor corrosion on the exterior of vibrator cans can be removed by an appropriate non-powered abrasive method in Chapter 11 of this manual.

**2.3.22 Motors, Generators, Blowers, and Fans.** Ensure that motors, generators, blowers, and fans are mounted securely and operate without excessive vibration and noise. Make sure these components are free of corrosion, clean, properly lubricated, show no evidence of overheating, and have free moving blades that do not contact enclosures or other stationary parts. Clean and lubricate these components periodically as required by the equipment system specific maintenance manuals to prevent corrosion and ensure proper operation.

**2.3.23 Waveguide Assemblies.** Ensure that waveguide assemblies, including any platings used on them, are free of dents, pitting and other types of corrosion, and arc burns. Minor corrosion on exterior surfaces at places where the organic finish system is damaged or deteriorated can be removed by an appropriate non-powered abrasive method (the mildest method that is effective) per procedures in Chapters 8 and 11 of this manual followed by touch-up of the finish system with a like material applied per procedures in TO 1-1-8. More extensive corrosion on exterior surfaces and any corrosion on interior surfaces of waveguide assemblies requires replacement of the assemblies.

TO 1-1-700



MIL-L-87177, LUBRICANT, CORROSION PREVENTIVE  
COMPOUND, WATER DISPLACING 32



MIL-PRF-81309, LUBRICANT, CORROSION PREVEN-  
TIVE COMPOUND 46

**2.3.24 Protection for Spare Connectors and/or Receptacles.** Installed spare and/or unused connectors/receptacles with attached protective mating covers shall have these covers installed on them while they are not being used after spraying the connector/receptacle with a film of MIL-L-87177, Type I, Class B or MIL-PRF-81309, Type III, Class 2 avionics grade, water displacing, corrosion preventive compound (CPC). This will prevent corrosion and/or damage to the connectors/receptacles while not in use.

**2.3.25 Moisture and Fungus Proofing.** C-E-M equipment and its shelters, vans, and radomes shall be moisture proofed per procedures in Chapter 6 of this manual to prevent damage and subsequent corrosion caused by mildew, fungus, and microorganisms in tropical environments.



## CHAPTER 3 CORROSION THEORY

### 3.1 PURPOSE.

This chapter is an introduction to corrosion theory, the causes of corrosion, and the factors which influence its development. The various forms of corrosion and the effect of corrosive environments on equipment and metals are described. The purpose of this discussion is to provide maintenance personnel with the background knowledge necessary to understand the causes of corrosion and to minimize corrosion damage.

### 3.2 DEFINITION OF CORROSION.

Corrosion is the electrochemical deterioration of a metal because of its chemical reaction with the surrounding environment. This reaction occurs due to the tendency of metals to return to their naturally occurring states, usually oxide or sulfide ores. For example, iron in the presence of moisture and air will return to its natural state, iron oxide or rust. Aluminum and magnesium form corrosion products that are white oxides or hydroxides. When a water solution containing soluble salts is present, corrosion of many alloys can occur easily at ambient temperatures. This type of corrosion can be treated effectively by maintenance personnel as discussed in this manual. Corrosion can also occur in the absence of water, but only at high temperatures such as those found in gas turbine engines. However, the most common type of corrosion (and the one that can be most effectively treated by maintenance personnel) is electrochemical corrosion.

### 3.3 CHEMICAL DEFINITIONS.

**3.3.1 Atom.** An atom is the smallest unit of an element. There are over 100 elements, including metals such as gold, platinum, silver, carbon, titanium, copper, nickel, chromium, iron, tin, lead, uranium, aluminum, cadmium, beryllium, zinc, magnesium, and non-metals such as sulfur, hydrogen, oxygen, nitrogen, chlorine, helium, and boron.

**3.3.2 Electron.** An electron is a negatively charged particle much smaller than an atom. An electric current occurs when electrons are forced to move through metal conductors. Electrons flow through water solutions only in the presence of ions.

**3.3.3 Ions.** Atoms or groups of atoms bound together which are either positively or negatively charged. An electric current

occurs when ions are forced to move through water solutions. Ions cannot move through metal conductors.

**3.3.4 Electrolyte.** An electrolyte is a liquid (usually water) solution containing ions. Salt water is an electrolyte; an aqueous (water) solution of sodium ions and chloride ions. Electrochemistry is the branch of chemistry concerned with chemical reactions at surfaces in contact with electrolytes.

### 3.4 THEORY OF CORROSION.

All structural metals will corrode to some extent in a natural environment. When a metal corrodes, the metal atoms lose electrons and become positively charged metal ions in the electrolyte. In solution, the positively charged metal ions can combine with negatively charged ions to form corrosion products, such as metallic chlorides, oxides, hydroxides, sulfides, etc. Four conditions must exist before this type of corrosion can occur.

- A metal which has a tendency to corrode must be present (the corroding metal is known as the anode).
- A dissimilar conductive material (the cathode) which has less tendency to corrode than the anode must be present (such as a different metal, a protected part of the same metal, or conductive plastics).
- A conductive liquid (electrolyte) must connect the anode and cathode (so that ions can carry electric current between them).
- Electrical contact between the anode and cathode (usually in the form of metal-to-metal contact) must exist so that electrons can move from the anode, where they are released, to the cathode.

Eliminating any one of the four conditions (see Figure 3-1) stops corrosion. For example: a paint film on a metal surface prevents the conducting liquid (electrolyte) from connecting the anode and cathode and stops the electric current (see Figure 3-2). Another example: two connected dissimilar metal parts placed in distilled water corrode very slowly due to a lack of ions in solution to conduct the electric current; in sea water the corrosion reaction is accelerated by a factor of 1000 or more (see Figure 3-3).

TO 1-1-700

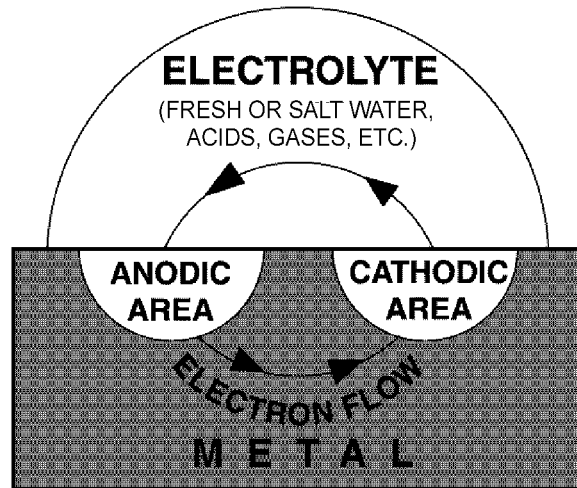

Figure 3-1. Simplified Corrosion Cell

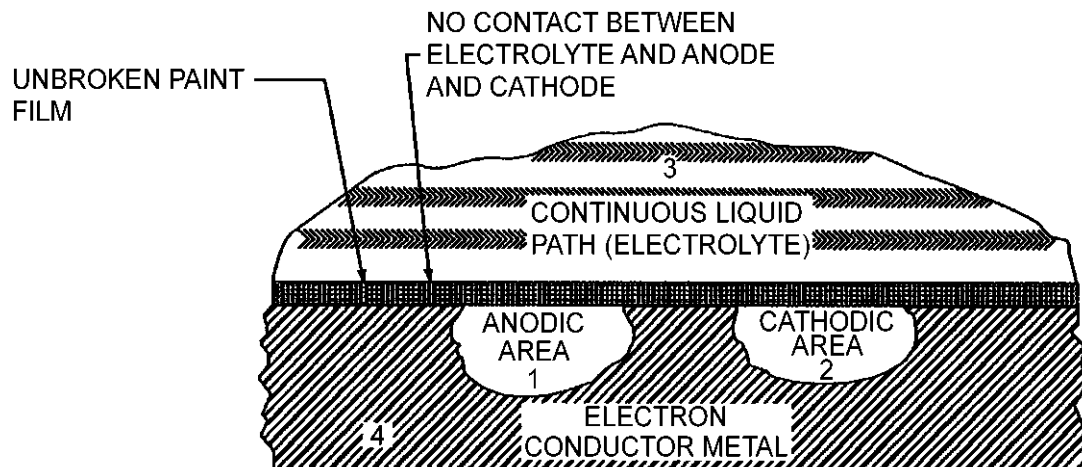

Figure 3-2. Elimination of Corrosion by Application of an Organic Film to a Metal Surface



**Figure 3-3. Effect of Sea Water on Galvanic Corrosion**

### 3.5 DEVELOPMENT OF CORROSION.

All corrosive attacks begin on the surface of a metal. If allowed to progress, corrosion can penetrate into the metal. If corrosion begins on an inside surface of a component (for example, the inner wall of a metal tube), it may go undetected until perforation occurs. When corrosion products form, they often deposit on the corroding surface as a powdery deposit. This film of corrosion products may reduce the rate of corrosion if the film acts as a barrier to electrolytes. Some metals (such as stainless steel and titanium), under the right conditions, produce corrosion products that are so tightly bound to the corroding metal that they form an invisible oxide film (called a passive film), which prevents further corrosion. However, when the film of corrosion products is loose and porous (such as those of carbon steel, aluminum, and magnesium), an electrolyte can easily penetrate to the metal surface, continue the corrosion process, and produce more extensive damage than surface appearance shows. Paint coatings can sometimes mask the initial stages of corrosion. Since corrosion products occupy more volume than the original metal, painted surfaces should be inspected often for irregularities such as blisters, flakes, chips, lumps, and worm like tracks.

### 3.6 FACTORS INFLUENCING CORROSION.

Some factors which influence metal corrosion and the rate of corrosion are:

- Type of metal.
- Presence of a dissimilar, less corrodible metal (galvanic corrosion).
- Anode and cathode surface areas (in galvanic corrosion).
- Temperature.
- Heat treatment and grain direction.
- Presence of electrolytes (hard water, salt water, battery fluids, etc.).
- Availability of oxygen.
- Presence of different concentrations of the same electrolytes.
- Presence of biological organisms.
- Time of exposure to a corrosive environment.

**3.6.1 Type of Metal.** Most pure metals are not suitable for equipment construction and are used only in combination with other metals, and sometimes non-metals, to form alloys. Most alloys are made up of small crystalline regions called grains. Corrosion can occur on surfaces of those grains, which are less

## TO 1-1-700

resistant, and also at the boundaries between grains, resulting in pitting and inter granular corrosion. The metal alloys most commonly used in equipment construction are steel, corrosion resistant steel (CRES), aluminum, and magnesium. Cadmium, zinc, tin, nickel, and chromium are frequently used as protective platings. Silver and gold are used extensively within electrical and electronic equipment as electrical conductors while tin and lead are used in solders. Various metals have a wide range of corrosion resistance. The most active metals, those which tend to lose electrons easily such as magnesium and aluminum, corrode easily and are listed at the top or anodic end of Figure 3-17. The most noble metals, those which do not lose electrons easily such as gold and silver, do not corrode easily and are listed at the bottom or cathodic end of Figure 3-17.

### 3.6.2 Dissimilar Metal Coupling (Galvanic Corrosion).

When two dissimilar metals make electrical contact in the presence of an electrolyte, the rate at which corrosion occurs depends on the difference in their chemical activities, that is, their positions in the galvanic series (see Figure 3-17). The greater the difference in activity, the faster corrosion occurs. For example, magnesium would corrode very quickly when coupled with gold in a humid atmosphere; but aluminum would corrode very slowly, if at all, in contact with cadmium. A flashlight battery (or dry cell) is an example of galvanic corrosion put to practical use. In Figure 3-4, the zinc battery casing steadily corrodes supplying a steady flow of electrons, but only when the switch is closed. When the switch is open, there is no corrosion because electrons are not able to leave the zinc anode.

**3.6.3 Anode and Cathode Surface Area.** The rate of galvanic corrosion also depends on the size of the parts in contact. If the surface area of the corroding metal (the anode) is smaller than the surface area of the less active metal (the cathode), corrosion will be rapid and severe. When the corroding metal surface area is larger than the less active metal surface area, corrosion will be slow and superficial. For example, an aluminum fastener in contact with a relatively inert Monel structure may corrode severely, while a Monel bracket secured to a large aluminum member would result in a relatively superficial attack on the aluminum sheet (see Figure 3-5).

**3.6.4 Temperature.** Higher temperature environments tend to produce more rapid corrosion due to acceleration of chemical reactions and, in humid environments, higher concentration of water vapor in the air. In addition, nightly drops in temperature can cause greater amounts of condensation, leading to increased corrosion rates.

**3.6.5 Heat Treatment and Grain Direction.** When heat-treated, heavy sections of metals do not cool uniformly, the result can be a variation in chemical composition from one part of the metal to another. This can cause galvanic corrosion

if one area is more active than another. Alloys which are fabricated by rolling, extruding, forging, or pressing have different properties on its surface along the grain length as compared to those across the grains. For example, exposed end grains corrode much more easily than flattened elongated surfaces in sheet stock. This explains why exfoliation occurs at the edge of skin sheet sections or next to countersunk fasteners.

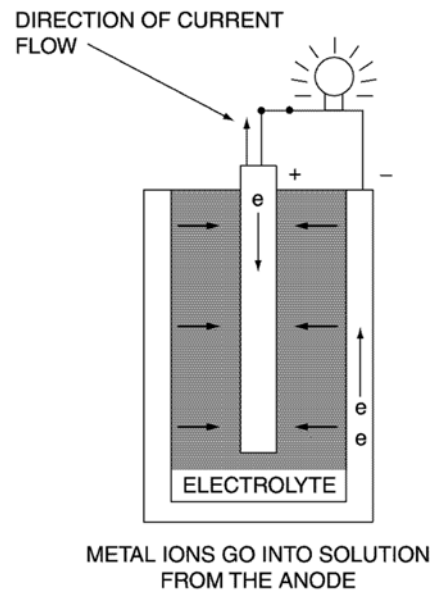
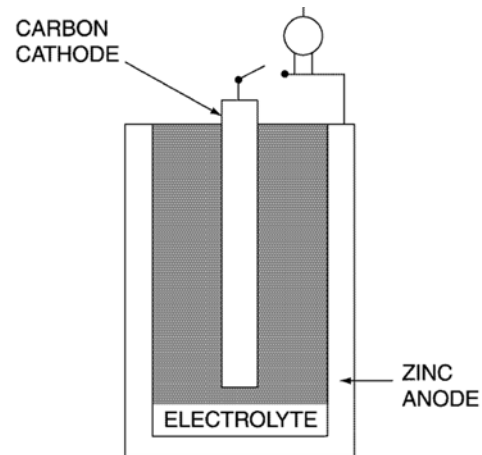
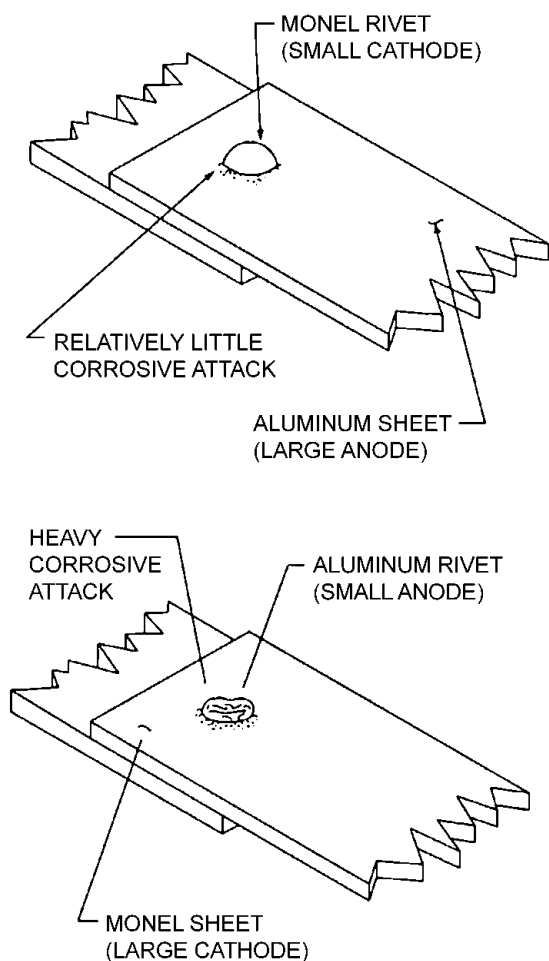

Figure 3-4. Galvanic Corrosion in a Flashlight Battery

**3.6.6 Electrolytes.** Electrically conducting solutions are easily formed on metallic surfaces when condensation, salt spray, rain, or rinse water accumulate. Dirt, salt, acidic stack gases, and engine exhaust gases can dissolve on wet surfaces, increasing the electrical conductivity of the electrolyte, thereby increasing the rate of corrosion.

**3.6.7 Oxygen.** When some of the electrolyte on a metal surface is partially confined (such as between faying surfaces or in a deep crevice) the metal in this confined area corrodes more rapidly than other metal surfaces of the same part outside this area. This type of corrosion is called an oxygen concentration cell or differential aeration cell. Corrosion occurs more rapidly than would be expected because the reduced oxygen content of the confined electrolyte causes the adjacent metal to become anodic to other metal surface areas on the same part immersed in electrolyte exposed to the air.



**Figure 3-5. Effect of Area Relationship in Dissimilar Metal Contacts**

**3.6.8 Electrolyte Concentration.** In the same way that metals can corrode when exposed to different concentrations of oxygen in an electrolyte, corrosion will also occur if the concentration of the electrolyte on the surface varies from one location to another. This corrosive situation is known as a concentration cell.

**3.6.9 Biological Organisms.** Slimes, molds, fungi, and other living organisms (some microscopic) can grow on damp surfaces. Once they are well established, the area tends to remain damp, increasing the possibility of corrosion. Their presence can cause the areas they occupy to have different oxygen and electrolyte concentrations. In addition, corrosive wastes are secreted which cause corrosion.

**3.6.10 Time.** As time elapses, metals naturally tend to corrode. In some cases, the corrosion process occurs at the same rate, no matter how long the metal has been exposed to the environment. In other cases, corrosion can decrease with time due to the barrier formed by corrosion products or increase with time if a barrier to corrosion is being broken down.

### 3.7 TYPES OF CORROSION.

Corrosion is catalogued in many ways. Occasionally, different names are used for the same type of corrosion. The common types of corrosion are described below.

**3.7.1 Uniform Surface Corrosion.** Uniform surface corrosion or etching results from a direct chemical attack on a metal surface and involves only the metal surface. On a polished surface, this type of corrosion is first seen as a general dulling or etching of the surface and, if the attack is allowed to continue, the surface becomes rough and possibly frosted in appearance. This type of corrosion appears uniform because the anodes and cathodes are very small and constantly shift from one area of the surface to another. An example is the etching of metals by acids. The discoloration or general dulling of metal created by exposure to elevated temperatures is not considered to be uniform surface corrosion.

**3.7.2 Galvanic Corrosion.** Galvanic corrosion occurs when different metals are in contact with each other and an electrolyte, such as salt water. It is usually recognizable by the presence of a buildup of corrosion at the joint between the metals. For example, aluminum skin panels and stainless steel doublers, riveted together in a structure, form a galvanic couple if moisture and contamination are present. Figure 3-6 shows galvanic corrosion of magnesium adjacent to steel fasteners. When metals well separated from each other in Figure 3-17 are known to be in electrical contact, galvanic corrosion is probably occurring.

**3.7.3 Pitting Corrosion.** The most common corrosion on aluminum and magnesium alloys is pitting (see Figure 3-7). It



## TO 1-1-700

is first noticeable as a white or gray powdery deposit, similar to dust, which blotches the surface. When the deposit is cleaned away, tiny pits or holes can be seen in the surface (see Figure 3-8). Pitting corrosion can also occur in other types of alloys. The combination of small active anodes with large passive cathodes causes severe pitting.

**3.7.4 Intergranular Corrosion.** Intergranular corrosion is an attack at the grain boundaries of the metal. A highly magnified cross section of any commercial alloy (see Figure 3-9 and Figure 3-10) shows the granular structure of the metal. It consists of quantities of individual grains and each one has a clearly defined boundary that differs chemically from the metal within the grain. Frequently, the grain boundaries are anodic (tend to corrode more easily) to the metal within the grain. When in contact with an electrolyte, rapid corrosion occurs at the grain boundaries. Figure 3-11 shows intergranular corrosion of a 7075-T6 aluminum alloy adjacent to steel fasteners. In this example, the grain boundaries are anodic to both the metal grain and the steel fasteners.

**3.7.5 Exfoliation Corrosion.** Exfoliation (see Figure 3-12 and Figure 3-13) is an advanced form of intergranular corrosion where the surface grains of a metal are lifted up by the force of expanding corrosion products occurring at the grain boundaries. The lifting up or swelling is visible evidence of exfoliation corrosion. Exfoliation occurs on extruded, rolled, wrought, and forged high strength aluminum and magnesium parts.

**3.7.6 Crevice/Concentration Cell Corrosion.** Crevice corrosion occurs when the electrolyte has a different concentration from one area to another. Electrolyte inside the crevice contains less oxygen and more metal ions than electrolyte just outside the crevice. As a result, the metal surfaces, even though they may be part of the same metal, have different activities; and corrosion occurs inside the crevice. This kind of corrosion also occurs when a surface is covered by a foreign material. There are three general types of crevice/concentration cell corrosion: (1) metal ion concentration cells; (2) oxygen concentration cells; and (3) active-passive cells (see Figure 3-14).

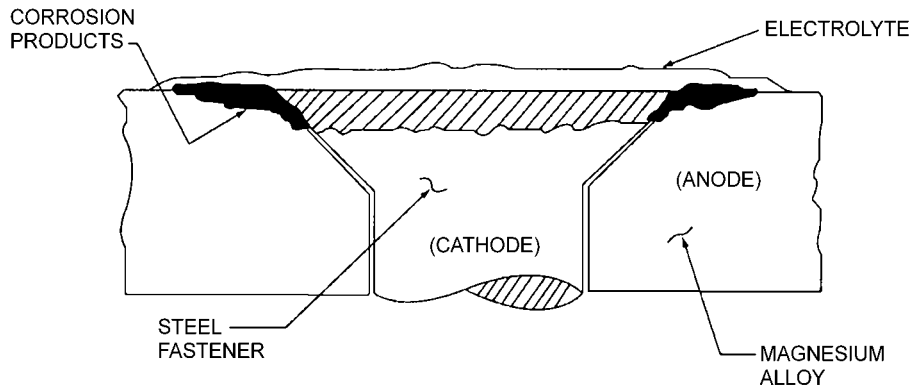

**Figure 3-6. Galvanic Corrosion of Magnesium Adjacent to a Steel Fastener**



**Figure 3-7. Pitting of an Aluminum Angle Assembly**

3.7.7 Metal Ion Concentration Cells. Stagnant electrolytes under faying surfaces will normally have a high concentration of metal ions, while a low concentration of metal ions will exist adjacent to the crevice created by the faying surfaces. The area of the metal in contact with the higher concentration

of metal ions will be cathodic and not show any signs of corrosion, but the area in contact with the lower metal ion concentration will be anodic and suffer corrosion. Figure 3-14, View A, illustrates metal ion concentration cell corrosion.

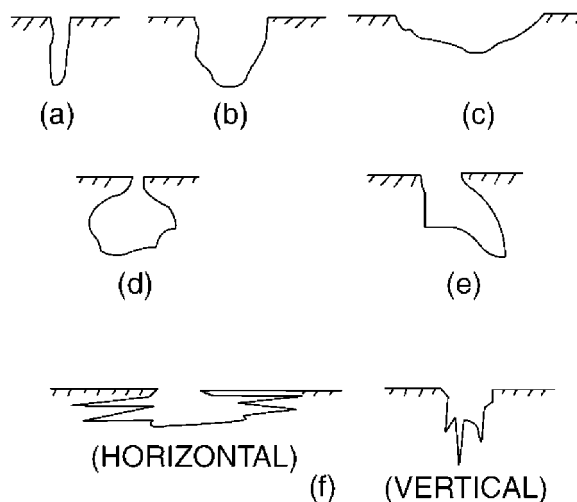

VARIATIONS IN THE CROSS-SECTION SHAPE OF PITS.

(a) NARROW AND DEEP. (b) ELLIPTICAL. (c) WIDE AND SHALLOW. (d) SUBSURFACE. (e) UNDERCUTTING. (f) SHAPES DETERMINED BY MICROSTRUCTURAL ORIENTATION.

Figure 3-8. Cross-section of Corrosion Pits

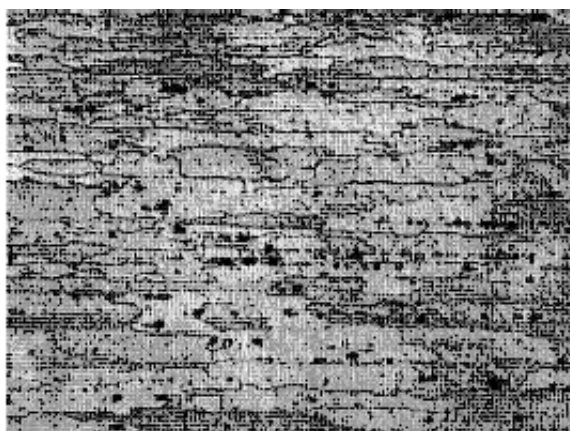

Figure 3-9. Cross-section of 7075-T6 Aluminum Alloy



## TO 1-1-700

**3.7.8 Oxygen Concentration Cells.** Electrolyte in contact with metal surfaces will normally contain dissolved oxygen. An oxygen cell can develop at any point where the oxygen in the air is not allowed to diffuse into the solution, thereby creating a difference in oxygen concentration between two points. Typical locations of oxygen concentration cells are under either metallic or non-metallic deposits (dirt) on the metal surface and under faying surfaces such as riveted lap joints. Oxygen cells can also develop under gaskets, wood, rubber, plastic tape, and other materials in contact with the metal surface. Corrosion will occur in the area of low oxygen concentration (anode) as illustrated in Figure 3-14, View B. Alloys such as stainless steel, which owe their corrosion resistance to surface passivity, are particularly susceptible to this type of crevice/concentration cell corrosion.

**3.7.9 Active/Passive Cells.** Metals which depend on a tightly adhering passive film, such as the oxide film on corrosion resistant steel, are prone to rapid corrosive attack by active-passive cells. The corrosive action usually starts with a deposit of dirt or salt, which creates an oxygen concentration cell. The passive film is then broken in the area of the salt deposit and the more active metal beneath the passive film will be prone to corrosive attack. This small anodic area will corrode rapidly due to the much larger area of the surrounding cathode (passive film). The result is rapid pitting of the surface, as illustrated in Figure 3-14, View C.

**3.7.10 Filiform Corrosion.** Filiform corrosion (see Figure 3-15) is a special form of oxygen concentration cell corrosion or crevice corrosion which occurs on metal surfaces having an organic coating system. It is recognized by its characteristic wormlike trace of corrosion products beneath the paint film. Filiform occurs when the relative humidity of the air is between 78% and 90% and when the surface is slightly acidic. It starts at breaks in the coating system, such as scratches and cracks around fasteners and seams, and proceeds underneath

the coating due to the diffusion of water vapor and oxygen from the air through the coating (see Figure 3-16). Filiform corrosion can attack steel, magnesium, and aluminum surfaces and may lead to more serious corrosion in some locations. Filiform corrosion can be prevented by storing equipment in an environment with a relative humidity below 70%, by using a coating system having a low rate of diffusion for oxygen and water vapors, by maintaining coatings in good condition, and by washing equipment to remove acidic contaminants from the surface (such as those created by pollutants in the air). Maintain coatings in good condition (prompt touchup around fasteners) and apply corrosion preventive compounds (CPC) when paint is damaged.



**Figure 3-10. Grain Structure of a Corroding Aluminum Surface**

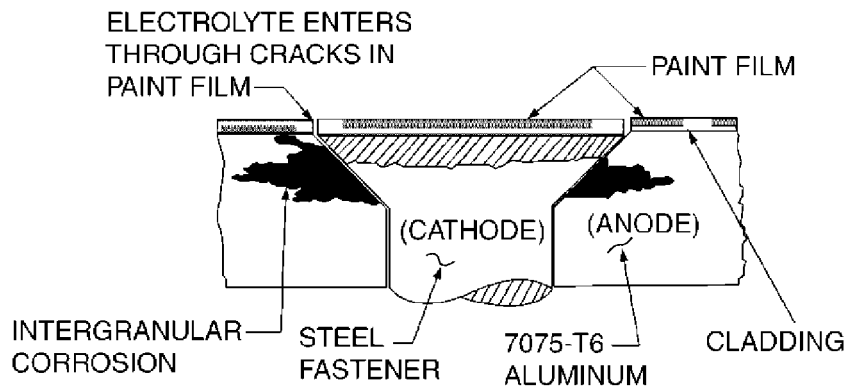

**Figure 3-11. Intergranular Corrosion of a 7075-T6 Aluminum Alloy Adjacent to Steel Fastener**



**Figure 3-12. Example of Exfoliation**



**Figure 3-13. Another Example of Exfoliation**

**3.7.11 Fretting Corrosion.** This is a special form of concentration cell corrosion which occurs in combination with surface wear. The corrosion products increase the wear of the surface and the wear exposes more bare metal surface to be corroded. The overall effect is greater than the single effects of

corrosion and wear added together. It has the general appearance of galling, in which chunks of metal are torn from the surface with corrosion at the torn areas or ragged pits. This type of corrosion occurs on faying surfaces of close tolerance and on parts under high pressure in a corrosive environment when there is slight relative movement of the parts such as that caused by vibration. Fretting corrosion is normally encountered in heavily loaded static joints which are subject to vibration and are not and/or cannot be sealed to prevent moisture entry, such as landing gear component attachment areas having lug holes with slight press fits or slip fit bushings with very close tolerance bolts passing through the bushings. Another area is wing root access panels or wing-to-body fairings, which are generally not tightly secured and cannot be sealed in faying surface

### **3.8 METALS AFFECTED BY CORROSION.**

Characteristics of corrosion on metals are summarized in Table 3-1. The following is a discussion of corrosion characteristics of metals commonly used on C-E-M and related equipment.

**3.8.1 Magnesium.** Magnesium alloys are the lightest metals used for C-E-M and related equipment structures. These alloys are highly susceptible to corrosion, which appears as white, powdery mounds or spots when the metal surface is exposed to the environment without a protective finish (see Figure 3-18). The normal oxide-carbonate film formed on magnesium alloys does not provide sufficient corrosion protection even in the mildest environment. The corrosion rate of a magnesium alloy increases when the alloy is immersed in water, periodically subjected to moisture, coupled to a dissimilar metal, or exposed to water in which conductive contaminants are dissolved. Corrosion of magnesium alloys can be greatly diminished by the use of the proper protective finish. Some magnesium parts have been originally protected by anodizing processes, such as the ASTM D1732, Class II, Type III (MIL-M-45202, Type I, Class A) HAE coatings and the ASTM D1732, Class II, Type II (MIL-M-45202, Type I, Class C) DOW 17 coatings. The HAE process can be identified by the brown to mottled gray appearance of the unpainted surface. DOW 17 coatings have a green to grayish-green color. Coatings of this type are thicker than those applied by immersion or brushing. Anodized finishes cannot be restored in the field. Care should be taken to minimize removal of these coatings.

TO 1-1-700

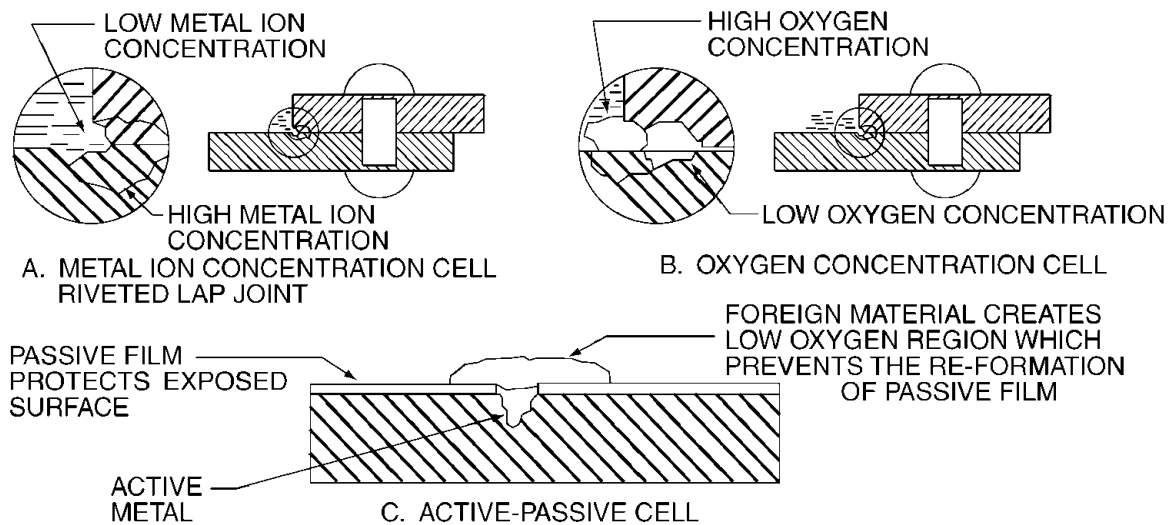
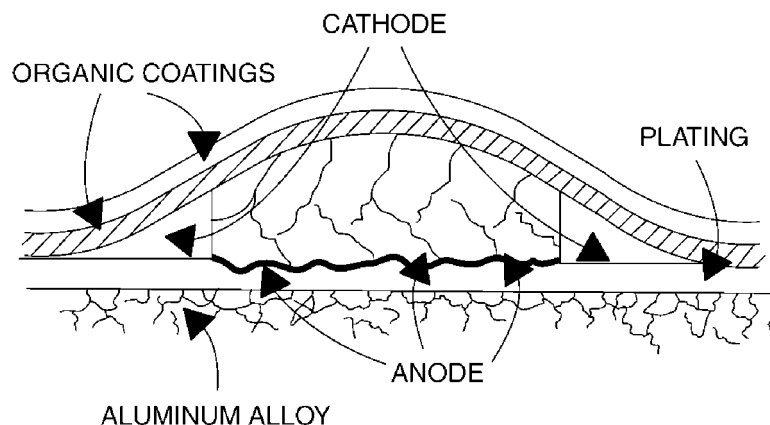

Figure 3-14. Concentration Cell Corrosion



Figure 3-15. Filiform Corrosion Found Under a Paint Coating on a Magnesium Alloy Panel



**Figure 3-16. Schematic of the Development of Filiform Corrosion on an Aluminum Alloy**

**3.8.2 Steel.** Ferrous (iron) alloys are used to manufacture many C-E-M and related equipment components and massive assemblies in structures, ground support equipment, and frames and bodies of trailers and vans, and lesser structural parts such as brackets, racks, and panels. If unprotected, ferrous alloy surfaces (with the exception of CRES or stainless steels) easily corrode or rust in the presence of moisture. Ferrous alloy surfaces of structures or assemblies are normally painted or plated and painted to prevent corrosion. Corrosion of steel is easily recognized because the corrosion product is red rust (see Figure 3-19). When ferrous alloys corrode, a dark corrosion product usually forms first, and it converts to red rust when moisture is present. Further attack is promoted because the rust absorbs moisture from the air.

**3.8.3 Aluminum.** Aluminum alloys are the most widely used materials for C-E-M cases, chassis', and support structures. Aluminum is highly anodic as evidenced by its position in the galvanic series (see Figure 3-17). However, the formation of a tightly adhering oxide film offers increased resistance under mild corrosive conditions. The corrosion products of aluminum (see Figure 3-20) are white to gray powdery materials (aluminum oxide or hydroxide) which can be removed by mechanical polishing or brushing with abrasive. It is anodic to most other metals and, when in contact with them, galvanic corrosion of the aluminum will occur. Aluminum alloys are subject to surface, pitting, intergranular, and exfoliation corrosion. In some cases, the corrosion products of the metal in

contact with aluminum are corrosive to aluminum. Therefore, it is necessary to clean and protect aluminum alloys to prevent corrosion. Since pure aluminum is more corrosion resistant as well as being more anodic than most alloys, aluminum alloy sheet stock is often covered with a thin layer of nearly pure aluminum called alclad. While fully intact, the alclad layer is very resistant to corrosion because a very adherent oxide film rapidly forms on its surface to protect it. Alclad is easily removed by harsh treatment with abrasives and tooling, exposing the more corrosion susceptible aluminum alloy base metal surface. If the break in the alclad layer is small, the alclad will sacrificially corrode and protect the exposed base metal alloy because it is more anodic than the alloy. In such areas, chemical conversion coatings, paints, and corrosion preventive compounds are especially important. In a marine environment, all aluminum surfaces require protection.

**3.8.4 Anodized Aluminum.** Some aluminum alloy parts are protected with an electrochemically applied oxide coating (i.e. anodize). An aluminum oxide film on aluminum is a naturally occurring protective film and anodizing merely increases the thickness and density of the oxide film. When this coating is damaged in service, it can be only partially restored by chemical conversion coating treatment of the damaged area (see Chapter 7 of this manual). Avoid damage (e.g. nicks and scratches) to the anodized surface during processing of anodized aluminum alloy parts.

TO 1-1-700

ANODIC (High Corrosion Potential)
Lithium
Magnesium Alloys
Zinc (plate)
Beryllium
Cadmium (plate)
Uranium (depleted)
Aluminum Alloys
Indium
Tin (plate)
Stainless Steel 430 (active)
Lead
1010 Steel
Cast Iron
Stainless Steel 410 (active)
Copper (plate)
Nickel (plate)
AM 350 (active)
Chromium (plate)
Stainless Steels 350, 310, 301, 304 (active)
Stainless Steels 430, 410 (passive)
Stainless Steel 13-8, 17-7PH (active)
Brass, yellow, Naval
Stainless Steel 316L (active)
Bronze 220
Copper 110
Stainless Steel 347 (active)
Copper-Nickel 715
Stainless Steel 202 (active)
Monel 400
Stainless Steel 201 (active)
Stainless Steels 321, 316 (active)
Stainless Steels 309 13-8 17-7 PH (passive)
Stainless Steels 304, 301, 321 (passive)
Stainless Steels 201, 31, 6L (passive)
Stainless Steel 286 (active)
AM355 (active)
Stainless Steel 202 (passive)
Carpenter 20 (passive)
AM355 (passive)
Titanium Alloys
AM350 (passive)
Silver
Palladium
Gold
Rhodium
Platinum
Carbon/Graphite
CATHODIC (Low corrosion potential)

Figure 3-17. Galvanic Series of Metals and Alloys in Sea Water



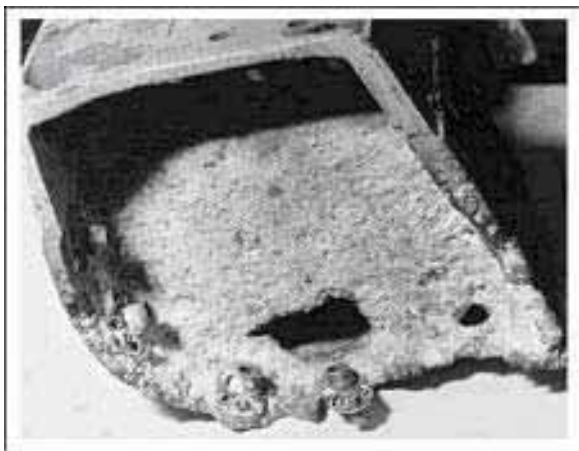

**Figure 3-18. Magnesium Corrosion Products**

**3.8.5 Copper and Copper Alloys.** Copper and copper alloys are quite corrosion resistant and corrosion is usually limited to staining and tarnish. Generally, such changes in surface conditions are not dangerous and should ordinarily have no effect on the part. Copper corrosion is evidenced by the accumulation of blue or blue-green corrosion products on the corroded part. Protective paint coatings are seldom required because of the inherent resistance of the metal. However, paint finishes may be applied for decorative purposes or if the normal tarnish or green patina on the copper is objectionable. The green patina is merely a thin coating consisting mainly of

basic copper sulfate and perhaps hydrated copper carbonate. The patina in the thin, firmly adhering state actually offers increased corrosion protection to the base metal, but the patina in a rough or frosted state should be removed. When coupled with most metals used in equipment construction, copper is the less active metal and greatly accelerates corrosion of the other metals. This is especially true in copper/aluminum couples. Examples are usually found in electrical components and in areas where copper bonding strips or wires are fastened to an aluminum chassis or structural components.

**3.8.6 Cadmium.** Metal parts are plated either to increase the corrosion resistance of the parts or to develop certain physical properties on the surface of the parts, such as abrasion (wear) resistance and high temperature oxidation resistance. Parts may also be plated to create a compatible dissimilar metal contact, to provide a sacrificial metal layer, or to provide a satisfactory surface for soldering. Cadmium is used as a coating to protect steel parts by acting as a sacrificial layer and to provide a compatible surface when a part is in contact with other metals such as aluminum alloys. Attack on cadmium is evidenced by brown to black mottling of the surface or as white powdery corrosion products. When cadmium shows mottling and isolated voids or cracks in the coating, the plating is still performing its protective function. The cadmium plate on iron or steel continues to protect until such time as actual iron rust appears (see Figure 3-21). Even then, any mechanical removal of corrosion products should be limited to metal surfaces where cadmium has been depleted.



**Figure 3-19. Steel Corrosion Products (Rust)**

TO 1-1-700



Figure 3-20. Aluminum Surface Corrosion Products

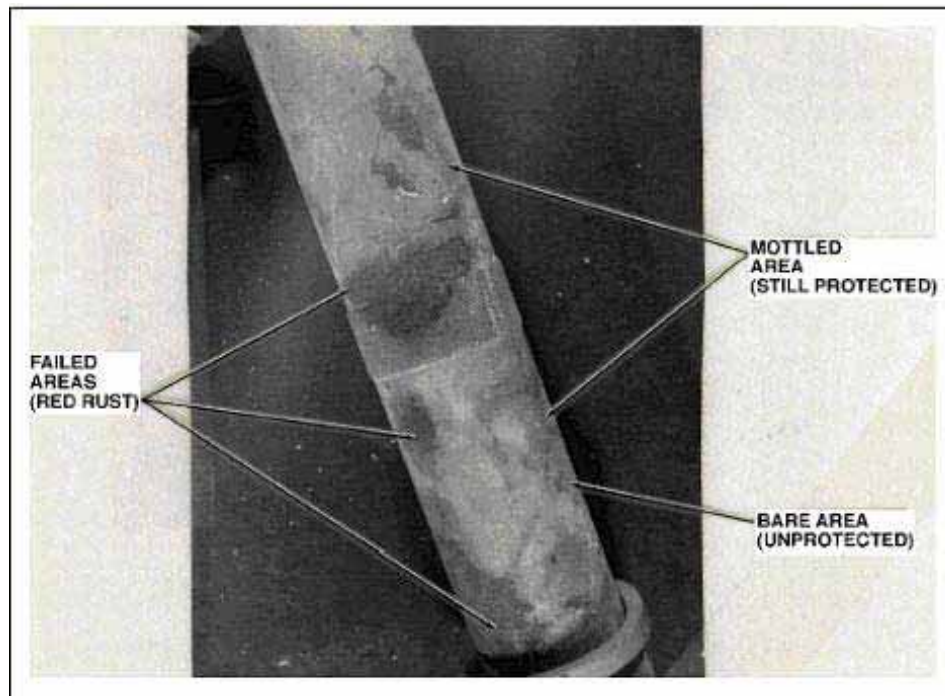
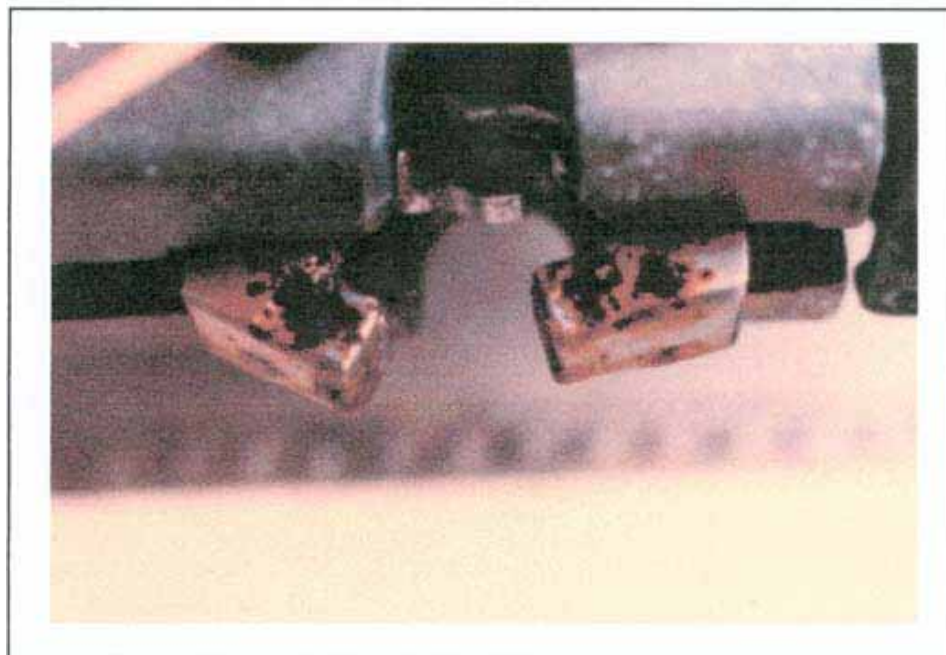

Figure 3-21. Cadmium Plated Surface Conditions





**Figure 3-22. Failed Chromium Plating**

**Table 3-1. Corrosion of Metals - Type of Attack and Appearance of Corrosion Products**

Alloys	Type of Attack to Which Alloy Is Susceptible	Appearance of Corrosion Product
Magnesium Alloy	Highly susceptible to pitting	White, powdery, snow-like mounds, and white spots on the surface.
Low Alloy Steel (4000-8000 series)	Surface oxidation and pitting, surface, and intergranular	Reddish-brown oxide (rust).
Aluminum Alloy	Surface pitting, intergranular, exfoliation, and fretting	White to gray powder.
Cadmium (used as a protective plating for steel)	Uniform surface corrosion; used as sacrificial plating to protect steel	From white powdery deposit to brown or black mottling of the surface.
Stainless Steels (300-400 series)	Crevice/concentration cell corrosion; some pitting in marine environments; corrosion cracking; intergranular corrosion (300 series); surface corrosion (400 series)	Rough surface; sometimes a red, brown, or black stain.
Nickel-base Alloy (Inconel, Monel)	Generally has excellent corrosion resistance qualities; susceptible to pitting in sea water	Green powdery deposit.
Copper-base Alloy, Brass, Bronze	Surface and intergranular corrosion	Blue or blue-green powdery deposit (patina).
Chromium (plate)	Pitting (promotes rusting of steel where pits occur in plate)	No visible corrosion products; blistering of plating due to rusting of the base metal and lifting of plating.
Silver and Gold	Gold - none; Silver - tarnish from sulfides in air; can cause galvanic corrosion of contacting metals	Black tarnish deposits on silver surfaces

**TO 1-1-700**

**3.8.7 CRES/Stainless Steel.** Basically, stainless steels or corrosion resistant steels (CRES) as they are more properly described, are alloys of iron with chromium and nickel. Many other elements, such as sulfur, molybdenum, vanadium, cobalt, columbium, titanium, and aluminum are added in various amounts and combinations to develop special characteristics. Stainless (CRES) steels are much more resistant to common rusting, chemical action, and high temperature oxidation than ordinary steels, due to the formation of an invisible oxide film or passive layer on the surface of these alloys. Corrosion and heat resistance are the major factors in selecting stainless (CRES) steels for a specific application. However, it should be well understood that stainless (CRES) steels are not the cure-all for all corrosion problems due to service conditions which can destroy the oxide film on their surfaces. Stainless (CRES) steels are highly susceptible to crevice/concentration cell corrosion in moist, salt laden environments and can cause galvanic corrosion of almost any other metal with which they are in contact if proper techniques of sealing and protective coating are ignored. Stainless (CRES) steels may be magnetic or non-magnetic. The magnetic steels are identified by numbers in the American Iron and Steel Institute (AISI) 400-series, such as 410, 430, etc. These steels are not as corrosion resistant as the non-magnetic steels which are identified by numbers in the AISI 300-series, such as 304, 316, etc. The AISI 300-series steels have nickel contents ranging from 6% to 22%, while the 400-series steels have nickel contents of only 2%.

**3.8.8 Nickel and Chromium.** Nickel and chromium are used as protective platings. Chromium plating is also used to provide a smooth, wear-resistant surface and to reclaim worn parts. Where corrosion resistance in a marine environment is required, a nickel under-coat is used. The degree of protection is dependent upon plating thickness. Both of these metals form continuous oxide coatings that can be polished to a high luster and still protect not only themselves but also any underlying metal. Chromium platings contain micro-cracks, and corrosion/rust originates on the base metal below these separations and spalls the plating from the surface. Figure 3-22 shows the results of a failed chromium plate.

**3.8.9 Silver, Platinum, and Gold.** These metals do not corrode in the ordinary sense, although silver tarnishes in the presence of sulfur. The tarnish is a brown-to-black film. Gold tarnish is not really corrosion but is a very thin layer of soils or contaminants that shows up as a darkening of the reflecting surfaces. Silver and gold are used extensively in C-E-M equipment because of their high degree of conductivity and solderability. All these metals are highly cathodic to almost all other metals and can cause severe galvanic corrosion of almost any metal with which they are in contact in the presence of moisture if joint areas are not sealed or otherwise insulated.

**3.8.10 Graphite (Carbon) Fiber/Epoxy Composites and Fiberglass Materials.** Graphite or carbon fiber/epoxy composites are materials consisting of reinforcing fibers in a matrix of an organic epoxy resin. They are an important class of materials because of their high strength-to-weight ratios and high stiffness. Since carbon is the least active metal in the galvanic series, it will accelerate the corrosion of any metal to which it is coupled; so insulation, usually with sealants, between graphite/epoxy composites and other metals is an absolute necessity to prevent dissimilar metal attack on the attached part. Graphite/epoxy composites are not frequently encountered in C-E-M and associated equipment, but fiberglass materials are used extensively as the foundation of printed circuit/wiring boards and skin panels of vans and shelters. Fiberglass materials consist of a mat of cut glass fibers or a woven mesh of long glass fibers in a matrix of either an epoxy or a polyester resin. Skin panels of some vans and shelters may be fabricated from Kevlar® fiber mesh in an epoxy resin matrix. The fiberglass and Kevlar® materials present no galvanic couple problems, but the joint areas between these types of panels and their metal support frames or structures should be faying surface sealed to prevent fluid intrusion that can lead to corrosion of the metal components.

**3.9 CORROSIVE ENVIRONMENTS.**

Corrosion of C-E-M and associated equipment is caused by both natural and man-made environments. Natural conditions, which affect the corrosion process, are moisture, temperature, salt atmospheres, ozone, sand, dust, solar radiation, insects and birds, and microorganisms. Man-made conditions, which also affect the corrosion process, are industrial pollution, manufacturing operations, storage conditions, and shipment. By understanding these conditions, maintenance personnel will be better able to prevent damage by corrosion.

**3.9.1 Moisture.** Moisture is present in air as a gas (water vapor) or as finely divided droplets of liquid (mist or fog) and often contains contaminants such as chlorides, sulfates, and nitrates, which increase its corrosive effects. Moisture enters all areas of equipment that air can enter. All enclosed areas that are not sealed allow air to enter and leave as the pressure between inside and outside changes. These pressure changes occur when the atmospheric pressure changes and when the air temperature inside or outside of an enclosed area changes. Moisture condenses out of air when the air becomes too cool to hold all of the moisture in it. The dew found on equipment exterior surfaces, and many times on their interior surfaces, after a cool night is the result of condensation.

**3.9.2 Condensed Moisture.** Condensed moisture will usually evaporate as surrounding air warms; but its dissolved contaminants, including salts, will be left behind as residues or deposits on the surfaces. This can result in the build-up of soils and salt contamination. Condensed moisture and its con-

taminants can also be trapped in close fitting wettable joints, such as unsealed faying surfaces as well as in poorly ventilated areas, such as vans and shelters with deactivated cooling systems. Some gasket and packing materials will absorb several times their weight in water and, when heated, can transmit this retained moisture into semi-sealed areas. Moisture can accumulate in such areas through successive cycles of warming and cooling leaving pools of moisture and a relative humidity approaching 100%. This is known as the desert still effect. In addition, moisture can be drawn into poor bond lines by capillary action (wicking). Conditions of temperature and humidity can vary widely in separate sections of equipment, such as vans and shelters and even electronic equipment cases, depending on the success of environmental sealing condensation and location near heat-generating equipment.

**3.9.3 Effect of Moisture.** Electrolyte formation results from condensation and/or collection of moisture. All non-metals absorb some moisture, which may cause changes in dimensional stability, dielectric strengths, ignition voltages, volume and contact insulation resistances, and conductivities. In general, organic matrix composites, are adversely affected by moisture and may suffer a loss of strength and stiffness from exposure. Hermetic sealing (liquid and vapor proof at normal temperatures and pressures) is recommended for moisture-critical items such as capacitors and quartz crystals. TO 1-1-689-3 is an excellent source for additional information related to electronics equipment.

**3.9.4 Temperature.** Temperatures at the high end of the range for which equipment is designed may result in either improvement or degradation of equipment operational characteristics. Some electronic equipment may not function properly at high temperatures. Generally, corrosion and other harmful processes (such as the degradation of non-metallic materials) increase as temperatures rise, but in some instances, moderate increases in temperature may serve to reduce corrosion by preventing condensation. Growth of molds and bacteria is also inhibited by temperatures above 104 °F (40 °C). Operation at temperatures near the low end of the design range of below 32 °F (0 °C) generally reduces the rate of corrosion.

**3.9.5 Salt Atmospheres.** When dissolved in water, salt particles form strong electrolytes. Ocean waters contain from 3.5% to 3.9% salt and are the world's primary source of salt. Normal sea winds carry from 10 to 100 pounds of sea salt per cubic mile of air. Since dissolved salts are strong electrolytes, it is easy to understand why shipboard and coastal environments are highly corrosive.

**3.9.6 Ozone.** Ozone is made up of three molecules of oxygen instead of the normal two. It is a particularly active form of oxygen, which is formed naturally during thunderstorms by arcing in electrical devices, and by photochemical reactions in smog. When ozone is absorbed by electrolyte solutions in con-

tact with metals, it increases the rate of corrosion. It also oxidizes many non-metallic materials, being particularly harmful to natural and certain types of synthetic rubber. Rubber seals stored near welding equipment have experienced complete degradation.

**3.9.7 Other Industrial Pollutants.** Carbon (from internal combustion engine exhaust), nitrates (from agricultural fertilizers), ozone (from electrical motors and welding operations), sulfur dioxide (from engine exhaust and industrial and ship smoke stacks), and sulfates (from automobile exhaust) are important airborne pollutants. The combination of these pollutants contributes to the deterioration of non-metallic materials and severe corrosion of metals.

**3.9.8 Sand, Dust, and Volcanic Ash.** Sand, dust, and volcanic ash are present in many areas. In industrial areas, they often contain a number of tar products, ashes, and soot. Dust is also found in the tropic zones during times of little or no rainfall. Sand and dust are extreme problems in the deserts, since dry, powdery sand and dust are carried by wind. During sandstorms, they can penetrate sealed equipment as well as many internal areas of vans and shelters, and small sand particles are often blown as high as 10,000 feet by the siroccos (hot, dust laden winds). Sand, dust and volcanic ash are hygroscopic (water absorbing) and, when present on internal or external surfaces of equipment or electronic parts, can absorb and hold moisture. The presence of sand, dust and volcanic ash may also affect the operation of electrical contacts, prevent proper action of rotating motor-driven devices, and cause malfunctions of indicating instruments. Dust from volcanic areas contains chlorides and sulfates, which are extremely corrosive in the presence of moisture. Although small amounts of sand or dust may be unnoticed by operating personnel, they may be sufficient to promote corrosion and wear.

**3.9.9 Solar Radiation.** The two ranges of solar radiation most damaging to materials are ultraviolet, the range that causes sunburn, and infrared, the range that makes sunlight feel warm. On earth, maximum solar radiation occurs in the tropics and equatorial regions, but considerable damage occurs in the temperate zones as a result of solar heating, photochemical effects, and combinations of these two phenomena. Non-metals, especially organic and synthetic materials, are strongly affected by sunlight. Both natural and synthetic rubber deteriorates rapidly in sunlight. After extended exposure, plastics darken, paints lose their protective characteristics, polymers undergo marked decreases in strength and toughness, and colors fade. This can lead to removal of essential color-coding on tubing and electronic components. Most electronic equipment is housed in enclosed structures and is protected from solar radiation. Extra care must be taken in the selection and surface treatment of parts, such as cables and harnesses that are to be exposed to exterior environments.

**TO 1-1-700**

**3.9.10 Climate.** Warm, moist air, normally found in tropical climates tends to accelerate corrosion; while cold, dry air normally found in arctic climates tends to reduce corrosion rates. Corrosion does not occur in very dry conditions. For this reason, desiccants are used in shipping containers to produce very dry local environments. The operational climate extremes have always been considered in equipment design. However, certain areas within electronics equipment, vans, and shelters, such as air-conditioned and/or cooled areas, may be subjected to climatic conditions very different from external areas. Relatively warm, dry air that has been cooled by air conditioners, thus increasing its relative humidity, and ducted into interior areas of equipment, vans, and shelters without drying or passing it through an expansion valve can release sufficient moisture to accelerate corrosion. It is imperative to consider not only the exterior operational environment but also the environments in which C-E-M equipment will be fabricated, transported, reworked, repaired, and mounted inside a van or shelter.

**3.9.11 Desert.** Hot, wind-swept deserts create a severe maintenance problem because powdery dust can penetrate even supposedly sealed components. High daytime temperatures, high humidity (in areas such as the Persian Gulf), ultraviolet radiation, and fine dust are the four most serious, destructive elements of the desert climate. Non-metallic materials suffer the most damage from the hot desert climates where air temperatures during the day may reach 124 °F (51 °C). Temperatures inside closed containers may be 100 °F (38 °C) higher than external air temperatures.

**3.9.12 Temperate Zones.** The temperate or intermediate climate zone encompasses most of the North American and European continents. At various times of the year, these areas may approximate the extremes of polar, desert, or tropical temperatures and humidity. The temperate zone temperatures range from -25 °F to +59 °F (-32 °C to +15 °C) in the winter and from +59 °F to +125 °F (+15 °C to +52 °C) in the summer. The relative humidity (RH) also fluctuates between five and 100%. The most critical areas are coastal locations during the warm periods of the year in which the relative humidity approaches 100% RH at night and the air has high concentrations of salt. Moisture from this salt laden air can condense on equipment during early evening and morning hours, thereby causing serious corrosion. Because of its relatively mild temperatures, the temperate zone is also the most heavily populated. Consequently the smoke, smog, ozone, and corrosive fumes associated with heavy industry are also found there.

**3.9.13 Tropics.** The greatest challenge to the C-E-M equipment industries is to design equipment that is protected from corrosion and deterioration in the heat and humidity of tropical climates. Even though they encompass only a small portion of the earth's land area, the tropics demand the greatest amount of consideration from the standpoint of corrosion treatment and

control. Relative humidity of up to 100% RH at ambient air temperatures up to and above 85 °F (29 °C) create a formidable threat of corrosion. When high humidity and temperature conditions are combined with salt-laden air, the corrosive environment becomes extremely severe. The critical combination of high temperatures, condensation, high relative humidity, and contaminants such as salt and sand may cause catastrophic failure of equipment. Deterioration of the materials used in electronic equipment is also accelerated.

**3.9.14 Factors of Influence in Tropical Environments.**

Tropical environments are noted for long periods of heavy rainfall during which 100 inches or more of rain may fall. Extended periods of high heat and humidity contribute to rapid corrosion of metals, cracking and flaking of rubber and plastic materials, and deterioration of seals. Equipment, whether stored or in use, requires special protective containers/measures and frequent preventive maintenance. Microorganisms multiply excessively in tropical environments and attack many non-metallic materials. Many items become covered with fungi in a matter of hours. Electronic equipment requires special efforts for effective operation in the tropics. Intensive preventive maintenance and the best possible protective techniques are necessary for C-E-M and associated equipment in tropical environments.

**3.9.15 Manufacturing.** During the manufacture, assembly, or repair of C-E-M and associated equipment, many factors that might lead to corrosion may be introduced. The use of unsuitable materials and improper materials processing can cause corrosion. Assembly of parts in areas contaminated by fumes or vapors from adjacent operations may result in entrapment of the fumes or vapors in the equipment which may cause future corrosion. Spaces that are air conditioned without humidity control may be sources of condensed moisture.

**3.9.16 Storage.** Even traces of corrosive vapors in packages containing electronic parts may result in serious corrosion. Moreover, the natural breathing of packages may introduce moisture into the parts and equipment. Some packing materials have been known to decompose and emit corrosive vapors during periods of prolonged storage. Refer to the equipment system specific maintenance manual for additional storage information.

**3.9.17 Shipment.** During shipment, materials such as plastics and lubricants are often exposed to environments that were not considered during the design stage. Materials shipped by air are subjected to changes in atmospheric pressure and can lose volatile components by out gassing. The vibration and mechanical shocks associated with shipment by truck can damage protective coatings or platings. Shipment by ocean vessel may expose the equipment to corrosive marine environments, vibrations and shock from engines or sea conditions, and residual corrosive vapors from previous shipments.

Although packaging equipment in accordance with MIL-STD-2073-1 will protect the equipment from corrosive environments, packaging may be damaged during handling and thus become ineffective.

**3.9.18 Industrial and Ship Emitted Air Pollutants.** Smog, smoke, soot, and other airborne contaminants are extremely corrosive to exposed C-E-M equipment. Many of the fumes and vapors emitted by ships and from factories can greatly accelerate metal corrosion. Industrial atmospheres may exist over large areas, since wind may carry these corrosive gases many miles from their source. Generally, air pollutants, when combined with water, create electrolytic solutions and accelerate corrosion.

**3.9.19 Animal Damage.** Damage to C-E-M and associated equipment may be caused by insects, birds, and various small animals, especially in tropical environments. Equipment in storage is most susceptible to this type of attack, since animals may enter through vent holes or tears in packaging and sometimes build nests. Moisture absorbed by nests plus excretions from animals may cause corrosion and deterioration that goes unnoticed until equipment is put into use and fails. Another type of damage may occur when organic materials, such as upholstery, are shredded for nests or consumed as food.

**3.9.20 Microorganisms.** Microbial attack includes the action of bacteria, fungi, or molds. Microorganisms are nearly everywhere and outnumber all other types of living organisms. Organisms that cause the greatest corrosion problems are bacteria and fungi. Damage resulting from microbial growth can result from: (1) the tendency of the growth to hold moisture which then causes corrosion; (2) digestion of the substrate as food for the microorganism; and (3) corrosion of the surface beneath the growth by secreted corrosive fluids.

**3.9.21 Bacteria.** Bacteria may be either aerobic or anaerobic. Aerobic bacteria require oxygen to live. They can accelerate corrosion by oxidizing sulfur to produce sulfuric acid or ammonia to produce nitric acid. Bacteria living on or adjacent to metals may promote corrosion either by depleting the oxygen supply or by releasing metabolic products. Anaerobic bacteria, on the other hand, can survive only when free oxygen is not present. The metabolism of these bacteria requires them to obtain food sources by oxidizing inorganic compounds such as iron, sulfur, hydrogen, and carbon monoxide. The resultant chemical reactions cause corrosion.

**3.9.22 Microbial Growth Requirements.** Fungi make up one class of microorganisms that feed on organic matter. Low humidity levels inhibit the growth of most species of fungi and bacteria. Ideal growth conditions for most fungi and bacteria are temperatures of +68 °F to +104 °F (+20 °C to +40 °C) and

relative humidity of 85% to 100% RH. It was formerly believed that microbial attack could be prevented by applying moisture-proof coatings to nutrient materials or by drying the interiors of compartments with desiccants. However, even some moisture-proof coatings are attacked by microorganisms, especially if the surface to which they are applied is contaminated. Some microorganisms can survive in spore form for long periods while dry, and can become active when moisture is available. When desiccants become saturated, they form what is known as a "desiccant pump" which pumps their absorbed moisture into the affected area by evaporation and allows microorganisms to begin to grow. Dirt, dust, and other airborne contaminants are the least recognized contributors to microbial attack. Unnoticed, small amounts of airborne debris may be sufficient to promote fungal growth by absorbing moisture.

**3.9.23 Microbial Nutrients.** Since fungi, bacteria, and other microorganisms are classified as living, it was previously thought that only materials derived from living organisms could provide them with food. Thus wool, cotton, feathers, leather, etc., were known to be microbial nutrients. To a large extent this rule of thumb is still valid, but the increasing complexity of synthetic materials makes it difficult, if not impossible, to determine from the name alone whether a material will support growth of microorganisms. Many otherwise resistant synthetic materials are rendered susceptible to microbial attack by the addition of chemicals, which change the properties of the material. In addition, different species of microorganisms have different growth requirements. The service life, size, shape, surface smoothness, cleanliness, environment, and species of microorganism involved all determine the degree of microbial attack on the affected item.

### 3.10 DEGRADATION OF NON-METALS.

Non-metallic materials (plastics, elastomers, paints, and adhesives) are not subject to electrochemical corrosion, since ions are not easily formed from non-metallic materials and their electrical conductivity is extremely low. The degradation of non-metals depends on the chemical makeup of the material and the nature of the environment. In general, non-metallic materials on C-E-M and related equipment are selected for their obvious performance properties (flexibility, transparency, strength, electrical resistance, etc.) as well as their resistance to heat, impact, abrasion, ultraviolet radiation, moisture, ozone and other detrimental gases, and operational fluids such as hydraulic fluid, lube oil, cleaners, deicing fluids, etc. However, the use of unauthorized maintenance chemicals and procedures can accelerate degradation and ultimately lead to material failure resulting in leakage, corrosion, electrical shorts, crazing, and/or mechanical failure.



**TO 1-1-700****3.11 PREVENTATIVE MAINTENANCE.**

The two most important factors in preventing corrosion, and the only ones which can be controlled by field personnel, are the removal of the electrolyte and the application of protective coatings. Since the extent of corrosion depends on the length of time electrolytes are in contact with metals, corrosion can be minimized by frequent cleaning/washing. If non-corrosive cleaners are used, the more frequently a surface is cleaned in a corrosive environment the less the possibility of corrosive attack. In addition, by maintaining chemical treatments, paint finishes, lubricants, and corrosion preventive compounds (CPC) in good condition, corrosion can be minimized. The degradation of non-metallic materials can be minimized by avoiding the use of unauthorized maintenance chemicals and procedures. In addition, when repair or replacement of non-metallic materials is required use only approved materials. Dedication to proper preventive maintenance practices maximizes equipment reliability.

**3.12 CORROSION EFFECTS ON GROUND ELECTRICAL AND COMMUNICATIONS, ELECTRONIC AND METEOROLOGICAL EQUIPMENT (C-E-M).**

C-E-M and electrical equipment are easily damaged by contamination with corrosion removal debris and by application of improper corrosion control materials. In addition, corrosion can severely damage and/or impair the proper operation of C-E-M equipment by totally destroying and/or severely deteriorating bonding/grounding connections, EMI shielding, conductive paths for electrostatic discharge. Many of the conventional corrosion treatment methods used on equipment structural components are also used on areas adjacent to or supporting C-E-M equipment, electrical equipment, wire bundles, and other electrical parts. Personnel performing corrosion control tasks on or around this equipment shall be familiar with materials and procedures used for corrosion prevention and control on electrical and electronic equipment to ensure that no damage to electrical or C-E-M equipment will occur. For more specific information, refer to TO 1-1-689-series, TO 1-1-691, TO 00-25-234, and TO 1-1A-14, and the system specific equipment maintenance manuals.

**3.12.1 Grounding and Bonding Connections.** Electrical bonding provides a low resistance electrical path between two or more conductive units or components so that the low end of the electrical circuits of each unit or component is at the same electrical potential. Grounding is electrical bonding that uses the primary structure to which an electronic system is mounted as the return for its electrical circuit. Corrosion products are non-conductive, so corrosion at a bonding/grounding connection can create an open circuit at the connection and cause the system to be inoperative.

**3.12.2 Dissimilar Metal Junctions, Corrosion Effects.**

Connecting two or more diverse electrical objects almost always in a dissimilar metal couple which is susceptible to galvanic corrosion that can rapidly destroy a bonding connection if proper precautions are not observed. Aluminum alloy jumpers/bonding straps are used for most bonding connections, but copper jumpers/bonding straps are sometimes used for bonding parts/components made of stainless/corrosion resistant steel (CRES), cadmium plated low carbon steel, aluminum alloy, brass, or some other metal. It is important to choose bonding and associated hardware materials such that the part in the connection that is most prone to corrode (the anode) is the easiest to replace. After the grounding or bonding connection has been made, overcoat the entire connection, including all bare metal areas from which the finish system was removed to provide good electrical contact, with a protective sealant for all permanent bonding/grounding connections and a film of water displacing corrosion preventive compound (CPC) overcoated with heavy wax-like CPC for bonding/grounding connections that must be frequently removed due to frequent equipment maintenance or replacement. Consult Chapter 7 of this manual for additional information on proper bonding/grounding installation and sealing as well as the proper materials for the hardware used. Consult TO 1-1A-8 for assistance with hardware selection.

**3.12.3 EMI Shielding.** Radiated electromagnetic fields produced by aircraft and ground radar antennas; ground C-E-M, aircraft, and missile transmitters; certain poorly designed electronic units; electric motors; lightning; or any other natural effects can interfere with ground C-E-M systems causing electrical and/or electronic malfunctions. This radiation is known as EMI (electromagnetic interference). To prevent malfunctions caused by EMI, electrically conductive shielding is either built into the electronic device or must be added to access panels, doors, or covers to: 1) prevent emission of EMI from its own circuits and; 2) prevent susceptibility to outside EMI. EMI seals and gaskets may also act as environmental seals in certain locations especially around doors and access panels. Since aluminum alloy surfaces oxidize very easily, thus becoming much less conductive and/or non-conductive, other materials have been used to make electrical contacts (i.e., beryllium-copper, titanium, silver plate, and tin-zinc coatings). However, since these contacts must provide a conductive path to an aluminum alloy or graphite/epoxy skin, galvanic corrosion often occurs at the junction of these dissimilar metals. When corrosion occurs, the conductive path is lost along with the EMI protection, making the equipment susceptible to electrical and electronic malfunctions caused by external radiation. Examples of system malfunctions are microprocessor bit errors, computer memory loss, false indicators (alarms, lights, read-outs), CRT ripple, false signals and power loss. The result of such malfunctions can be catastrophic (e.g., EMI radiation was responsible for an aircraft jettisoning a bomb while taking off from a carrier).



TT-I-735, ALCOHOL, ISOPROPYL

65



MIL-PRF-81309, LUBRICANT, CORROSION PREVENTIVE COMPOUND

46

### 3.12.4 EMI Seals and Gaskets, Corrosion Effects.

Examples of typical EMI shielding and gasket materials can be found in Chapter 7 of TO 1-1-691. Figure 7-1 shows an elastomeric seal and gasket with an embedded or attached conductor, Figure 7-2 shows a conductive elastomer gasket, Figure 7-3 shows metallic screens installed under composite cover, Figure 7-4 shows bonding cables on an access door, and Figure 7-5 shows bonding washers for an electronics equipment bay enclosure. When corrosion is observed in such areas, disassemble only the affected areas and remove the corrosion using the mildest available method necessary to remove the corrosion. Carefully clean the area with a lint free cloth wet with TT-I-735 Isopropyl Alcohol. Dry with a clean cloth. If replacement seals are available, install them in accordance with the appropriate equipment system specific maintenance manual. If replacement seals are not available or do not exist, spray the contacting surfaces with a light coating of MIL-PRF-81309, Type III avionics grade, water displacing CPC, and then reassemble. Periodically inspect repaired areas and areas known to be chronic problems. Consult Chapter 8 of this manual for additional information on effects and treatment of corrosion at EMI shielding and gasket locations.

### 3.12.5 Electrostatic Discharge Sensitivity (ESDS).

ESD is the transfer of electrostatic charge between bodies with different electrostatic potentials caused either by direct contact or induced by an electrostatic field. The most formidable ESD is lightning or electromagnetic pulse (EMP). Discharges from human bodies are the most frequent, least noticeable, and most ignored ESD. ESD affects electronic devices in a number of different ways. It can degrade performance, change the electri-

cal characteristics, or cause complete failure. Very Large Scale Integration Devices (VLSI) digital components are rapidly increasing in functional power, speed, and system applications in military C-E-M equipment. Making VLSI devices small results in less voltage required for circuit operation, but this decreases the noise immunity, and many are highly susceptible to damage from ESD. ESD affects many components such as transistors, resistors, Integrated Circuits (IC), and other types of semiconductor devices. A spark discharge resulting from an accumulation of electrostatic charges may not immediately destroy a device or cause it to become nonfunctional; it can be permanently damaged and yet perform its intended function. Additional exposure to spark discharges and/or continued use of the device can further damage the device until failure finally occurs. Known as latent failure, this results in a serious system reliability problem. It is essential that all personnel involved with repair, handling, transporting, and storing of ESDS items be concerned about ESD. Package, ship, and store all ESDS items in ESD protective materials. Consult TO 00-25-234 and TO 1-1-689-series for additional information on the Air Force ESD program.

### 3.12.6 ESD Protective Systems, Corrosion Effects.

Corrosion degrades electrical and mechanical properties of ESD protective systems and can significantly increase the susceptibility of ESDS equipment/components. Exposure to various field service environmental conditions in normal usage, sometimes in only 3 to 4 months, can cause galvanic corrosion problems to start. Corrosion between metal surfaces of C-E M equipment generates a two-fold problem: 1) structural weaknesses that open gaps in the exterior case of the equipment thus undermining the shield to internal ESDS components; and 2) damage and/or elimination of the conductive path that allows static electricity to be bled away from the equipment before it can begin sparking due to static discharge. Without regular maintenance and cleaning, the buildup of absorbed atmospheric pollutants, dust, and field debris can contribute to degradation of ESD shielding by promoting corrosion and acting as insulators themselves. Follow the instructions for protective measures required for ESDS equipment in Chapter 8 of this manual as well as procedures for maintaining proper bonding/grounding connections and protective EMI shields and gaskets in Chapters 8 of this manual respectively.





## CHAPTER 4

# COMPOSITE AND NON-METALLIC MATERIAL DEGRADATION AND REPAIR

### 4.1 PURPOSE.

The information contained in this Chapter is intended to provide guidance and references for maintenance personnel to test, inspect, and/or repair damaged/degraded non-metallic materials or components used in the construction of ground-based C-E-M equipment and its protective shelters, vans, and radomes. Repair parameters in this Chapter shall not be construed as specifying the extent of repair or refinish required, except where it is determined that repair of the existing defects will prevent the equipment from meeting operational requirements or will exceed allowable physical tolerances. The general methods described in this Chapter shall be used in conjunction with the equipment system specific maintenance manuals, instructions found elsewhere in this manual, MIL-HDBK-454, TOs 1-1-689-series, 1-1-691, 00-25-234, 31-1-69, 31-1-75, 35E4-1-162, and 00-25-108, and all specifications and drawings pertinent to maintenance on the equipment in question.

### 4.2 MATERIAL SUBSTITUTIONS.

Repair materials and processes shall be in accordance with applicable portions of system specific manuals or Air Force technical data. If a satisfactory substitute cannot be found or if any doubt exists as to the applicability of the substitute, forward the problem along with a recommended solution to the equipment System Program Manager (SPM) for resolution.

### 4.3 WORKMANSHIP AND SAFETY.

The following list of general requirements establishes repair standards of a nonspecific nature that determine acceptability of repaired equipment:

**4.3.1 Components and Parts.** Components and parts shall be repaired in a thoroughly workman-like manner using best manufacturing practices.

**4.3.2 Dimensions and Tolerances.** Dimensions and tolerances shall be in accordance with drawings and specifications pertinent to the equipment under repair. If not specified, dimensions and tolerances shall be in accordance with best manufacturing practices for the type of equipment being repaired.

**4.3.3 Tools and Tooling.** Tools and tooling used for maintenance and repair shall be appropriate for the task, in good

repair, and shall pose no undue safety hazards for operating personnel when used according to manufacturer's instructions.

**4.3.4 Safety and Health.** Repairs shall be conducted in accordance with all personnel safety and health standards pertinent to the type of equipment under repair and for the maintenance site used for the repair activity.

### 4.4 GENERAL REQUIREMENTS.

#### 4.4.1 Wood.

**4.4.1.1 Inspection.** Wood structures and surfaces shall be inspected at frequent periodic intervals to determine if they are damaged and the extent of damage to the wood material and to any applied protective coatings (see Figure 4-1).



**Figure 4-1. Electronic Shelter: Installed Wood Cabinetry**

**4.4.1.2 Repair.** Repair wood-to-wood joints using means comparable to those used in the original fabrication. Glued joints shall be securely bonded. Gluing, if required, shall be completed prior to application of sealers, if possible. If not possible, the surface areas to be glued shall be masked. Reinforcement of glued joints using metal brackets or plates is permissible, provided external appearance or equipment function and operation is not altered.

**4.4.1.2.1** Deeply scratched or gouged wood shall be repaired with an approved wood filler and sanded smooth and flush with surrounding surfaces. After sanding, the repaired area shall be sealed with an approved clear wood preservative per manufacturer's instructions for that product.

**TO 1-1-700**

4.4.1.2.2 If required, damaged wood may be replaced with new wood of equal or better quality. The quality of fabrication and appearance shall also be equal to or better than the original product. After fabrication, all new wood required for repair shall be sanded and sealed with an approved clear wood preservative in accordance with manufacturer's instructions for that product.

4.4.1.3 **Finish.** Inspect coated wood surfaces to determine if the paint system is damaged and the extent of the damage.

4.4.1.3.1 Surfaces with lightly damaged or deteriorated paint shall be sanded smooth to remove all cracked and loose paint material.

4.4.1.3.2 Before painting, all surfaces shall be clean, dry, and free of contamination. If required, surfaces shall be wiped with a clean rag using a suitable approved cleaner or solvent to remove oils, greases or other more persistent contamination. After cleaning, painted surfaces shall be lightly sanded. After sanding, surfaces shall again be wiped with a clean rag to remove all dust or other contamination resulting from the sanding process.



MIL-P-53030, PRIMER, EPOXY, WATER REDUCIBLE,  
LEAD, CHROME FREE

35



MIL-PRF-85285, COATING, POLYURETHANE, HIGH  
SOLIDS

50

4.4.1.3.3 After surface preparation, all new wood surfaces shall be primed with one coat of MIL-P-53030 water reducible epoxy primer, and finished with two coats of MIL-PRF-85285 polyurethane coating in a semi-gloss color to match the original color of the equipment or as modified per the equipment system specific maintenance manuals. Application shall be per procedures in TO 1-1-8.

4.4.1.3.4 Painted wood surfaces with repaired minor scratches or damage shall be prepared as described in paragraph 4.4.1.3.2 and painted with one coat of enamel in accordance with paragraph 4.4.1.3.3.

4.4.2 **Composite Materials.** Composite materials (e.g., fiberglass or other resin impregnated cloth materials) shall be inspected on a frequent periodic basis for damage and deterioration. If degradation is sufficient to seriously affect the function (or appearance, if essential) of the material, repair or

replacement shall be conducted. Repair or replacement shall be in accordance with best manufacturing practices, the equipment system specific maintenance manuals, and TOs 1-1A-12, 1-1-690, 31-1-69, 31-1-75, and 35E4-1-162.

4.4.3 **Fabric and Leather.** Fabric and leather materials shall be inspected on a frequent periodic basis for damage and deterioration. Fabric and leather parts such as carrying cases, belts, straps, tarps etc. shall be reasonably free from damage, deterioration or excessive wear. If degradation is sufficient to seriously affect the function (or appearance, if essential) of the material, repair or replacement shall be conducted. Repair or replacement shall be in accordance with best manufacturing practices, the equipment system specific maintenance manuals, TO 31-1-75, and any other approved Air Force procedures and methods for the material under repair. Additional specific requirements are:

4.4.3.1 Stitching and riveting shall be tight and unbroken.

4.4.3.2 Tips, eyelets and fasteners shall be securely fastened to fabric or leather materials.

4.4.3.3 Leather straps and belts shall show no cracks or breaks other than slight surface cracks when bent over a mandrel no more than 3/4-inch in diameter with the grain (smooth) side out.

4.4.3.4 Leather and fabric parts shall not be severely discolored, hard, brittle, cracked or split. They shall not have taken a permanent deformed set or exhibit the visual/physical effects of exposure to excessive heat or damaging environments.

4.4.4 **Plastic, Ceramics and Glass.** Plastic, ceramic and glass materials shall be inspected on a frequent periodic basis for damage and deterioration. If degradation is sufficient to seriously affect the function (or appearance, if essential) of the material, repair or replacement shall be conducted. Repair or replacement shall be in accordance with best manufacturing practices, the equipment system specific maintenance manuals, TO 31-1-75, and any other approved Air Force procedures and methods for the material under repair. Additional specific requirements are:

4.4.4.1 Plastic parts shall be free of cracks, breaks, chips, scratches or other severe damage that may impair their proper function or present a personnel health/safety hazard.

4.4.4.2 Finished surfaces will be smooth and shall not have burned, melted, warped or other heat-damaged areas.

4.4.4.3 Ceramic insulating materials will be free of surface cracks or glazing. Minor chips are acceptable providing the electrical insulation properties and function is not impaired or present a personnel health/safety hazard.

4.4.4.4 Glass parts shall be free of cracks, breaks, severe chipping, sharp edges or scratches that may impair their function or present a personnel health/safety hazard.

4.4.4.5 Electrical wires and cables having plastic jacket insulation shall not be painted or coated with greases or oils except as required for protection from moisture and fungus. Consult TOs 00-25-234, 1-1-689-series, 1-1A-14, and 31-1-75 for additional information.

4.4.5 Rubber. Rubber materials and parts shall be inspected on a frequent periodic basis for damage and deterioration. If degradation is sufficient to seriously affect the function (or appearance, if essential) of the material, repair or replacement shall be conducted. Repair or replacement shall be in accordance with best manufacturing practices, the equipment system specific maintenance manuals, TO 31-1-75, and any other approved Air Force procedures and methods for the material under repair. Additional specific requirements are:

4.4.5.1 Rubber parts and components shall be in a live condition with sufficient resilience to ensure proper function. Rubber materials shall not be cut, torn, crushed, stretched, distorted or worn to the extent that they no longer function properly for their intended purpose. Installation methods shall be in accordance with the equipment system specific maintenance manual and any other approved Air Force procedures.

4.4.5.2 Natural and synthetic rubber shall not be painted or oiled. As a general rule, grease should not be applied to rubber parts, but some parts, such as "O" rings, require a grease coating (consult the appropriate equipment system-specific maintenance manual).

4.4.5.3 Many types of rubber are subject to fungus growth (e.g., mold, mildew) which can cause deterioration of the rubber and corrosion of surrounding metal surfaces. If fungus is noted on rubber parts, they should be cleaned in accordance with methods in Chapter 6 of this manual for fungus removal and reinspected for damage or deterioration.

4.4.5.4 If damaged rubber material is found, it shall be replaced with new rubber material of equal or better quality and properties. Installation methods shall be in accordance with the equipment system specific maintenance manual and any other approved Air Force procedures.

4.4.6 Felt. Felt materials shall be inspected on a frequent periodic basis for damage and deterioration. If degradation is sufficient to seriously affect the function (or appearance, if essential) of the material, repair or replacement shall be conducted. Repair or replacement shall be in accordance with best manufacturing practices, the equipment system specific maintenance manual, TO 31-1-75, and any other approved Air

Force procedures and methods for the material under repair. Specific requirements are:

4.4.6.1 Felt shall be inspected for tears, hardening, wear, fungi, or other evidence of damage, deterioration or failure that results in serious degradation of function. If damaged felt is found, it shall be replaced with new felt material of equal or better quality and properties. Installation methods shall be in accordance with the equipment system specific maintenance manual, TO 31-1-75, and any other approved Air Force procedures.

4.4.6.2 Felt materials shall not be painted. Oil or grease shall not be applied to felt materials.

4.4.7 Honeycomb and Foam-Beam. Maintenance and repair of honeycomb and foam-beam structure materials as defined by paragraphs 4.4.7.1 through 4.4.7.4 shall be repaired per the procedures and methods specified in Chapter 4 of TO 35E4-1-162.

4.4.7.1 Foam-Beam (aluminum face sheets bonded to polyurethane composite core)

4.4.7.2 Paper Core (aluminum face sheets bonded to resin-impregnated paper honeycomb core)

4.4.7.3 Polymer (Plastic) Core (aluminum face sheets bonded to fiberglass honeycomb core)

4.4.7.4 Aluminum Core (aluminum face sheets bonded to aluminum honeycomb core)

4.4.8 Gaskets. Gaskets shall be inspected on a frequent periodic basis for damage and deterioration. If degradation is sufficient to seriously affect the function (or appearance, if essential) of the material, repair or replacement shall be conducted. Repair or replacement shall be in accordance with best manufacturing practices, the equipment system specific maintenance manual, TO 31-1-75, and any other approved Air Force procedures and methods for the material under repair. Additional specific requirements are:

4.4.8.1 Gaskets will be live, resilient and have no breaks, tears, cracks or chips that would impair making a tight seal for the intended application.

4.4.8.2 Cork or paper gaskets, when disturbed by removal of parts from equipment, shall be replaced with a closed cell rubber gasket having the same physical dimensions.

4.4.8.3 Gaskets showing evidence of permanent set or deformation shall be replaced.

**TO 1-1-700**

4.4.8.4 Installed gaskets shall meet mating edges or surfaces evenly, shall have no high spots and shall not protrude excessively.

4.4.8.5 Replacement gasket materials shall be of equal or superior quality to the gasket replaced.

4.4.9 Lenses and Optical Surfaces. Optical components shall be inspected on a frequent periodic basis for damage and deterioration. If degradation is sufficient to seriously affect the function (or appearance, if essential) of the component, repair or replacement shall be conducted. Repair or replacement shall be in accordance with best manufacturing practices, the equipment system specific maintenance manual, TO 31-1-75, and any other approved Air Force procedures and methods for the component under repair. Additional specific requirements are:

4.4.9.1 Mirrors, ground glass, optical surfaces, etc. will be clean, firmly mounted and free from cracks, scratches or significant discoloration. Minor defects shall be permissible where they do not interfere with or degrade the normal function and operation of the associated equipment.

4.4.9.2 Optical systems such as viewfinders, rangefinders, enlargers, projectors, viewers, etc. shall be aligned and adjusted in accordance with equipment manufacturer's specifications and the equipment system specific maintenance manual.

4.4.9.3 Lens elements shall be fastened securely and accurately in their mounts.

4.4.9.4 There shall be no evidence of foreign material on or between optical element surfaces (lenses, mirrors, etc.). All optical element surfaces shall be cleaned in accordance with original equipment manufacturer specifications and the equipment system specific maintenance manual.

4.4.10 Labels. Labels shall be inspected on a frequent periodic basis for damage and deterioration. Specific requirements are:

4.4.10.1 Paper labels shall be mounted in accordance with procedures in Chapter 2 of TO 31-1-75.

4.4.10.2 Labels other than paper and decals shall be securely and firmly mounted using screws or rivets.

**4.5 DEGRADATION PREVENTION**

4.5.1 Weather. All reasonable precautions shall be taken to protect equipment and materials from exposure to direct sunlight, humidity and/or temperature extremes, precipitation, or other hostile environmental conditions (e.g., corrosive atmospheres, dust, harsh chemicals, etc.). Protection shall include: avoidance of damaging environments when possible; use of approved protective coatings, sealants, enclosures, containers or shrouds; and frequent periodic inspections followed by immediate maintenance and remediation using procedures in the equipment system specific maintenance manuals, instructions found elsewhere in this manual, MIL-HDBK-454, TOs 1-1-689-series, 1-1-691, 00-25-234, 31-1-69, 31-1-75, 35E4-1-162, and 00-25-108, and all specifications and drawings pertinent to maintenance on the equipment in question when damage or deterioration is detected.

4.5.2 Damage. Frequent periodic inspections for damage shall be conducted and followed by immediate repair actions in accordance with all appropriate equipment system specific maintenance manuals, instructions found elsewhere in this manual, MIL-HDBK-454, TOs 1-1-689-series, 1-1-691, 00-25-234, 31-1-69, 31-1-75, 35E4-1-162, and 00-25-108, and all specifications and drawings pertinent to maintenance on the equipment in question.

4.5.3 Normal Wear. Equipment shall be used in accordance with all appropriate operation and maintenance instructions to provide optimum performance and obtain maximum useful service life.

## CHAPTER 5

### PACKAGING (STORAGE AND SHIPPING)

#### 5.1 GENERAL.

This chapter is intended for use by depot and field level maintenance personnel as a guide for proper corrosion prevention and control of Ground Communications, Electronics, and Meteorological Equipment (C-E-M) during storage and shipment.

**5.1.1 Packaging.** Packaging is used to prevent physical/mechanical damage or harm to items during storage, issue, or transfer and to provide protection from corrosion causing elements. All items (serviceable, repairable, etc.) placed in storage or shipped to another activity (including depot) should be preserved in order to prevent deterioration from corrosion, mildew, mold, and decay as well as to protect from attack by microorganisms, vermin, or rodents. The type of preservation required for stored and/or shipped equipment and parts depends on the packaging process, material, containers and condition of the items before being packaged.

#### 5.1.2 Military Specifications, Standards, and Manuals.

All activities involved with corrosion prevention and control of C-E-M equipment during storage and shipment shall use this technical manual in conjunction with TOs 1-1-8, 1-1-689-series, 1-1-691, AFPAM (I) 24-237 and equipment system specific maintenance manuals as a guide for corrosion prevention and control. Numerous military specifications, standards, and manuals are mentioned throughout this chapter and should be referred to as directed.

#### 5.2 LEVELS OF PROTECTION.

Specifying the level of protection provides the level of military preservation and packing that a given item requires to ensure that it is not degraded during shipment and storage. Specific levels of protection are as follows:

**5.2.1 Military Level of Preservation.** This is the required preservation designed to protect an item during shipment, handling, indeterminate storage, and distribution to consignees worldwide.

**5.2.2 Military Level of Packing.** There are two levels of packing:

**5.2.2.1 Level "A"** is protection required to meet the most severe worldwide shipment, handling, and storage conditions. A Level "A" pack, in tandem with the applied preservation, must be capable of protecting material from the effects of direct exposure to extremes of climate, terrain, and operational

and transportation environments. Examples of situations which indicate a need for use of a Level "A" pack are: storage of War Reserve Material (WRM), mobilization, strategic and theater deployment and employment, open storage, and ship deck loading. Examples of containers used for Level "A" packing requirements include, but are not limited to, overseas type wood boxes, and reusable plastic and metal containers.

**5.2.2.2 Level "B"** is protection required to meet moderate worldwide shipment, handling, and storage conditions. A Level "B" pack, in tandem with the applied preservation, must be capable of protecting material not directly exposed to extremes of climate, terrain, and operational and transportation environments. Examples of situations which indicate a need for use of a Level "B" pack are: shipment of security assistance materials/Foreign Military Sales (FMS) materials and fully containerized overseas shipments. Examples of containers used for Level "B" packing requirements include, but are not limited to: domestic wood crates, weather resistant fiber-board containers, fast pack containers, weather-resistant fiber drums, and weather-resistant paper and multi-wall shipping sacks.

#### 5.3 CLEANING.

Cleaning is the first step in preventing corrosion. The success of preservation and packing operations depends upon the items being clean.

**5.3.1 Contaminated Surfaces.** A preservative film will not protect an item if the surfaces are dirty or are covered with corrosion-producing contaminants. When surfaces of items are dirty or are covered with substances that are not part of the items, they are contaminated.

**5.3.2 Post Wash Protection.** The fact that items have been cleaned and dried does not ensure that they will remain free from future contamination. Cleaning may increase the possibility of damage to an item by removing a protective film and leaving its surfaces exposed to the direct attack of destructive forces. Applying protection as soon as possible after cleaning will help prevent the attack.

#### 5.4 CLEANING COMPOUNDS.

Cleaning compounds work by dissolving soluble soils, emulsifying oily soils, and suspending solid soils. There are several types of cleaning compounds, each of which cleans a surface using one or more of these mechanisms.





- When high strength steels (typically 180 KSI and above), some high strength aluminum, and some stainless steels are exposed to acid paint removers, plating solutions, other acidic materials (cleaners, etc.), and even some alkaline materials, a cathodic reaction on the metal surface produces hydrogen. The hydrogen diffuses into the bulk metal, accumulating at grain boundaries and weakens the structure.
- If the part is under load or contains residual manufacturing stresses, sudden catastrophic failure known as hydrogen embrittlement occurs when the part can no longer sustain the internal and/or applied stresses.
- Hydrogen embrittlement has been known to occur in parts stressed to only 15% of the nominal tensile strength of the metal.

**5.4.1 Alkaline Cleaners.** Many alkaline cleaners are not authorized for cleaning of Air Force equipment because they are incompatible with the polyimide insulation on the electrical wiring used on a great deal of military equipment. Cleaning compounds conforming to MIL-PRF-87937 and MIL-PRF-85570 and that are listed on the QPL for each specification have been tested and proven compatible with polyimide insulation.

**5.4.2 MIL-PRF-87937, Types I and IV and MIL-PRF-85570, Types I and II.** Types I and IV of MIL-PRF-87937 and Types I and II of MIL-PRF-85570 all contain detergents and foaming agents and work the same way as any detergent solution. Type I cleaners of both specifications contain solvents and are more effective for removal of heavy oils and greases such as wire rope lubricant, but they cannot be used in poorly ventilated areas due to their solvent content.

**5.4.3 MIL-PRF-87937, Type IV and MIL-PRF-85570, Type II.** Types IV of MIL-PRF-87937 and Type II of MIL-PRF-85570 are all good general cleaners for removal of dirt, grime, light oils, and hydraulic fluid; and they contain no solvents.

## 5.5 SOLVENTS.

Cleaning solvents dissolve oily and greasy soils so that they can be easily wiped away or absorbed on a cloth. However, solvents differ significantly in their cleaning ability, toxicity, evaporation rate, effect on paint, and flammability. A-A-59601, Type II and/or MIL-PRF-680, Type II are the most common cleaning solvents used due to their low toxicity, mini-

mal effect on paint, and relative safety. Other solvents such as alcohols, ketones, chlorinated solvents, and naphtha, are specialized materials restricted for use, as recommended in Table 3-2 of TO 1-1-691.

## NOTE

- Solvent cleaning operations are becoming more and more limited due to environmental regulations. Determine local requirements regarding limitations on type and volume used and disposal from your work center supervisor, safety officer, and/or bioenvironmental engineer.
- A-A-59601 Dry Cleaning and Degreasing Solvent PD680 and MIL-PRF-680 Degreasing Solvent, replace the old P-D-680 Dry Cleaning and Degreasing Solvent. MIL-PRF-680 has been reformulated to reduce hazardous air pollutants by reducing the aromatic content of the solvent, while A-A-59601 is identical to P-D-680.

## 5.6 ITEM CLEANING REQUIREMENTS.

When preserving items for shipment or storage, clean and dry all items by any suitable process that does not harm the item before applying preservation techniques. Basic cleaning requirements are listed in MIL-STD-2073-1. In addition, consult TOs 1-1-689-series and 1-1-691 for further information on cleaning.

## NOTE

Complex items will not be disassembled without prior authorization and/or technical instructions.

**5.6.1 Cleaning Materials Knowledge.** Cleaning requires knowledge of the materials and methods needed to remove corrosive contaminants and fluids that tend to retain contaminants. The selection of a cleaning process depends on the characteristics of the item, the nature of the contaminants, availability of cleaning materials and equipment, and the safety hazards involved.

## 5.7 CONTAINER CLEANING REQUIREMENTS.

Not only must the item(s) be free from contaminants but the shipping or storage container must also be clean, dry and free from corrosion and damage producing contaminants.

**5.7.1 Shipping Container Protection.** Shipping containers require special attention due to their requirement to protect items packed or stored in them from the elements. If left open and in the elements, they may cause more damage to the parts than providing protection for items packed in them with the



extent of damage depending on the length of time the items or equipment is left in them.

**5.7.2 Unprotected Shipping Containers.** Shipping containers and equipment not protected from or used in the elements (e.g., rain, dust, snow, etc.) require cleaning and drying more frequently to prevent corrosion.

**5.7.3 The Effects of Moisture on Equipment Cases (Containers).** Thousands of dollars have been spent to repair or replace equipment due to improper care, use, maintenance and storage of containers used to protect equipment from things such as rain, heat, cold, etc.

**5.7.3.1** The most common type of container consists of an outer case of composite or metal material with foam cushioning material formed to fit the item which is placed in the container.

**5.7.3.2** Since cushioning material absorbs and holds moisture very well it can cause damage to the equipment in the form of corrosion and mold.

**5.7.3.3** If a container is left open after unpacking, there is a very good chance for collecting moisture from humidity, rain and water intrusion. If the moisture isn't removed from the container before the equipment is returned, the moisture will, over time, cause the item to corrode or rust.

**5.7.3.4** It has been documented that equipment such as tripods have arrived at depot with more than an inch of water in their cases. This caused the tripods to corrode and rust to the point that minor maintenance such as lubrication which was to have been performed at the depot was insufficient. Major maintenance, such as disassembly, repair and many times complete replacements was required (see Figure 5-1, Figure 5-2, and Figure 5-3). Not only was the equipment damaged, but the container required drainage and drying, and sometimes, complete replacement adding man hours and/or equipment replacement cost to the depot support task.

**5.7.3.5** Proper care should be taken with any container to help reduce the effect of corrosion damage to equipment. The procedures below will help in that effort:

- a. Open containers within an area or under condition where moisture is at a minimum.
- b. Once the item is removed, close the container as soon as possible.
- c. Store the container out of the elements and in a dry climate controlled area.

- d. Ensure that the container is dry and free from moisture before repacking the equipment or item in it.
- e. Wipe the equipment and container dry before placing equipment in the container.
- f. Ensure the equipment and the container is dry and free from contaminants before placing it in storage.

Taking these steps along with using common knowledge will not only help reduce corrosion but will also save money by limiting the number of man hours used for repair and equipment replacement cost.



**Figure 5-1. Tripod Storage Case**



**Figure 5-2. Corroded Tripod Part**



**Figure 5-3. Corroded Tripod**

## 5.8 BASIC PRINCIPLES OF PRESERVATIVE PROTECTION.

Preservatives are materials that are applied to, or come in contact with, items to protect them from deterioration resulting from exposure to environmental conditions during shipment and storage.

**5.8.1 Preservatives.** Preservatives should be applied whenever items require protection against deterioration and corrosion.

**5.8.2 Barriers.** Some preservatives protect items by providing a barrier against moisture, air, and other agents of corrosion and are known as contact preservatives.

**5.8.3 Volatile Corrosion Inhibitors.** Other preservatives protect items by releasing vapors which deposit an invisible protective film on the items. These materials are called volatile corrosion inhibitors (VCI).

## 5.9 CLASSIFICATION OF PRESERVATIVES.

There are preservatives for metals and for non-metals. Preservatives are classified on the basis of the material to be preserved and are either permanent or temporary. Preservatives for metals are intended to protect items from corrosion and rusting while those used on non-metals are intended to protect against deterioration by hardening, drying, aging, decaying, rotting, or decomposing.

## 5.10 METHODS OF PRESERVATION.

A Special Packaging Instruction (SPI) or Technical Order (TO) prescribing a method of preserving a particular item or group of items takes precedence over general guidelines.

**5.10.1 Preservation Methods.** Preservation methods are standardized and have become generally known as Method 10 (physical protection), Method 20 (preservative coating only), Method 30 (waterproof protection), Method 40 (water vapor

proof protection) and Method 50 (water vapor proof protection with desiccant).

**5.10.2 MIL-STD-2073-1.** When there are no specific instructions, or for complete details on methods of preservation, general requirements, and suggested methods of application, refer to MIL-STD-2073-1 for a listing of the groups and their usage.

## 5.11 CONTACT PRESERVATIVES FOR METALS.

Many finished metal items require a preservative coating that is easily removed and yet will not rub or abrade off. Several temporary preservatives have been developed by adding water displacing compounds and inhibiting compounds to lubrication oils, greases, and hydraulic fluids. These preservatives have different consistencies and require different methods of application. Information on the various types of preservatives can be found in MIL-STD-2073-1 and Chapter 7 of this manual where the various groups with their usages are listed.

## 5.12 VOLATILE CORROSION INHIBITORS (VCI).

VCI compounds are white crystalline powders similar in appearance to fine talc. In some instances, the crystals are used directly for preserving interiors of engines and other applications, but the most widely used types of these materials are in the form of coated and/or impregnated papers.

**5.12.1 VCI Coatings.** As a coating, the chemical is mixed with casein that acts as a bonding agent or adhesive to stick the crystals to the paper surface.

**5.12.2 Impregnated Papers.** For impregnated papers, the paper is soaked in a solution containing a dissolved or suspended inhibitor; and when the liquid evaporates, the crystals are left impregnated in the fibers of and on the surface of the paper.

## 5.13 LIMITATIONS OF VCI.

VCI materials will not protect all metals from corrosion. For certain metals, VCIs tend to increase the rate of corrosion. VCI materials must not be used to protect any assemblies containing optical systems or precision moving parts that have been coated with a preservative or lubricant, unless otherwise specified. This does not include items protected with bonded films, such as a molybdenum disulfide dry film lubricant.

## 5.14 EFFECT OF HEAT, LIGHT, ACIDS, AND STRONG ALKALIS ON VCIS.

VCI materials lose their effectiveness as the temperature increases and they decompose if exposed to direct sunlight for extended periods. They also decompose in the presence of acids or strong alkali.

### 5.15 PRECAUTIONS FOR VCI USE.

When a VCI is used with items, assemblies, and subassemblies containing cadmium, zinc plating, zinc alloys, magnesium alloys, lead alloys, and alloys of other metals including solders and brazing alloys, plastics, painted parts, or components of natural or synthetic rubber, precautions must be taken. Assemblies containing parts made of these materials should not be packed with a VCI until proof is established that they have passed the compatibility test required by MIL-I-8574. Direct contact of a VCI with nonferrous metals except aluminum and aluminum alloys should be avoided unless specific permission had been granted.

### 5.16 VCI USE.

VCI materials offer effective protection to iron and steel that is equal to or better than that provided by the more commonly used contact preservative compounds. They provide good protection to areas where it would be impossible or impractical to apply a grease or oil type preservative to an item. Such areas as small holes, blind holes, cups, cavities, or threads are also protected by VCI vapors.

5.16.1 VCI Protection Usage. VCIs offer a choice of degrees of protection varying from temporary protection to items during processing operations, through protection for shipment and immediate use, to complete protection for long-term storage or overseas shipment.

5.16.2 VCI Usage Benefits. The simplicity and ease of application of VCIs result in monetary savings by reducing labor and time in the complicated preserving and cleaning operations normally associated with the use of grease and oil type preservatives.

### 5.17 VCI PACKAGING MATERIALS SPECIFICATIONS.



VCI materials may include ingredients irritating to the eyes and skin of some people. Do not rub or wipe eyes while handling VCI treated material. After handling, wash hands thoroughly with soap and water.

These materials are covered in several specifications and are available in the forms of treated kraft paper, barrier materials, paperboard wrapping, cushioning, oils, crystalline powders, and other types.

5.17.1 MIL-PRF-3420, Packaging Materials, Volatile Corrosion Inhibitor Treated, Opaque. This specification establishes the requirements for materials (kraft paper, barrier

materials, paperboard wrapping, and cushioning) which are treated with a corrosion inhibitor. The treated materials come in two forms, three classes, and seven styles. Forms "a" and "b" represent carrier materials which have been coated or impregnated respectively with corrosion inhibitors. The three classes relate to the strength of the material, and the seven styles relate to the composition of the material.

5.17.2 MIL-PRF-22019, Barrier Materials, Transparent, Flexible, Sealable, VCI Treated. This material is available in two types. Type I is intended for use where a heat-sealable, VCI treated barrier material is required. Type II is used where either production processing or custom hand processing requires a cold-sealable, VCI treated barrier material.

5.17.3 MIL-B-22020, Bags, Transparent, Flexible, Sealable, VCI Treated. These bags come in two classes:

5.17.3.1 Class 1 is intended for use where heat-sealable, transparent, VCI treated bags are required. They are made from barrier material qualified under Type I of MIL-PRF-22019.

5.17.3.2 Class 2 bags are intended for use where pressure cold-sealable, transparent, VCI treated bags are required and are fabricated from Type II material of MIL-PRF-22019. They are available in eleven sizes, from as small as 2-1/2 in. x 3 in. to as large as 10 in. x 13 in.

5.17.4 MIL-I-22110, Inhibitors, Corrosion, Volatile, Crystalline Powder. VCI crystals provide corrosion protection for most metals under specific conditions. This VCI can be sprayed, atomized or dusted over the entire surface of the item. See MIL-I-8574 for application and use criteria.

5.17.5 Other Forms of VCIs. Although specifications have not yet been issued covering some other forms of VCIs available to industry, they may be used if permitted by the military activity concerned.

5.17.5.1 These are tablet forms of VCIs which can be used in automated packaging of small items such as bolts, pins, dowels, screws, drills, taps and dies, etc.

5.17.5.2 VCI crystals compounded with a non-caking agent and supplied in 2-ounce cotton bags: VCI treated kraft paper, spirally-wound fiber cans (MIL-C-3955), fiberboard boxes coated with a VCI; and aerosol type VCIs dissolved in alcohol are also available.

### 5.18 APPLICATION OF VCI.

The following procedures should be used when applying VCI for the protection of metals.

## TO 1-1-700

**NOTE**

- If a vapor degreaser is used, operation and control instructions furnished by the manufacturer of the degreaser must be strictly followed to prevent the possibility of acid residues being left on the item which would render the VCI ineffective as well as promoting corrosion.
  - When a VCI material is to be used on assemblies containing operational lubricants, the compatibility of the specific VCI with the lubricants being used must be established prior to using the VCI.
  - Prior to the application of the VCI to the assemblies, any excess oil must be drained off.
  - Items protected with bonded films such as molybdenum disulfide solid film lubricants require no special treatment prior to using a VCI.
- a. Clean and dry items in accordance with requirements of MIL-STD-2073-1.
  - b. After cleaning the items completely enclose the item in VCI treated materials or wrap with strips of material without any other material between the item and the wrapping. Complete wrapping, where feasible, is preferred.
  - c. Wrap by placing the treated face of the material toward the item being wrapped.
  - d. Apply the wraps in such a manner that any air entering the pack will pass through and/or over the surface of the VCI before reaching the item.
  - e. Apply the VCI treated materials no more than 12 inches away from any surfaces to be protected.
  - f. If using VCI treated transparent bags, MIL-B-22020, the opening should be heat sealed whenever possible.

**5.19 DESICCANTS.**

A desiccant is any substance that draws moisture from its environment and retains it. Different desiccant products have different properties such as absorption rates, capacities, effective operating temperature ranges, etc.

**5.19.1 Usage.** Desiccants are used when humidity and moisture need to be mitigated. They are typically an inexpensive, inert and environmentally safe product which keeps products dry very effectively.

**5.19.2 Application.** The application of a desiccant involves segregating the item from the environment. Desiccants absorb moisture until they are completely saturated. If new air is allowed to pass into the protected areas the desiccant will eventually become saturated or "full". That is why when using desiccant it is important to place the item in a relatively isolated condition such as a well-sealed carton lined with a poly bag or a full-fledged heat sealed foil barrier bag with the desiccant inside. The desiccant will dry the air inside the container and keep the item dry.

**5.19.3 Usage Areas.** When properly used, desiccants should keep products dry for many years. The key to a good result with desiccant is good packaging. Remember a desiccant is like a sponge.

**5.19.4 Moisture.** Use desiccant wherever moisture is detrimental to the item. If the item is susceptible to corrosion it is a good idea, but not necessary to use it along with a VCI. The more layers of protection you have the better.

**5.19.5 Benefits.** The benefits of using desiccant products are:

- They are very inexpensive.
- They are clean, dry and environmentally safe.
- They are easy to use and save labor and repair costs.
- They present virtually no health concerns.

**5.20 DESICCANT APPLICATION.**

The following procedures should be use during the application of desiccants:

**NOTE**

When direct contact is absolutely unavoidable, the desiccant shall be isolated from the item with MIL-PRF-121 barrier material and MIL-DTL-6060, as applicable.

- a. Desiccants shall be in standard unit sized bags conforming to MIL-D-3464, Type I, unless Type II or III is specified or required because of special characteristics of the item.
- b. Place the desiccant in a location in the pack/container or item most accessible to voids in the item or pack interior.



- c. Secure the desiccant by tying, taping, etc. or in specially designed desiccant baskets affixed to the container interior (some desiccants are supplied in self adhesion packs).
- d. Secure the desiccant adequately to prevent it from shifting, moving and preventing it in all circumstances from coming into direct contact with critical surfaces of the enclosed item.
- e. Removing the desiccant and inserting it into the unit pack shall be the last action before final sealing of the bag or container.
- f. Once desiccant is applied and the bag or container is sealed/closed, place a Method 50 label on the outer surface to indicate that a desiccant is placed inside (see Figure 5-4 and Figure 5-5).

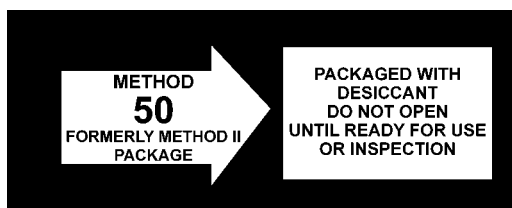

Figure 5-4. Method 50 Label



Figure 5-5. Placement of Desiccant in Electronic Area

## 5.21 CUSHIONING.

MIL-STD-2073-1 states that shock and vibration absorption shall be provided by cushioning materials or devices that adequately protect the contents and packaging components from physical damage during handling, shipment, and storage. Cushioning shall be placed as close to the contents as practicable. A non-corrosive wrap shall be placed between the item and all corrosive type cushioning media.

**5.21.1 Purpose.** The purpose of cushioning is the protection of an item from physical and mechanical damage afforded an item by means of compressible and resilient material designed to absorb the energy of shocks and vibration caused by external forces.

**5.21.2 MIL-HDBK-304.** To better understand the characteristics and functions of cushioning materials and how they function, refer to MIL-HDBK-304, Package Cushioning Design.

## 5.22 METHODS OF CUSHIONING.

Cushioning is usually accomplished by any of four methods or a combination thereof. They are known as floated item, floated pack, corner pads and side pads, and shock mounts.

**5.22.1 Floated Items.** The item is floated in non-corrosive and low moisture content cushioning material and placed within a unit container. This is perhaps the method most commonly used for cushioning small, lightweight, fragile items against shock, vibration, and abrasion. Since a container may be dropped on any one of its faces, edges or corners, the cushioning material is designed to withstand the full impact of the entire weight of the item in any direction (see Figure 5-6).

**5.22.2 Floated Pack.** The item is packed in an interior container which in turn is floated in cushioning material. This method is generally used in connection with semi-fragile items of medium size and weight. The item is initially packed in an interior container, then floated in cushioning, and placed into an exterior container. Since the materials will not come in contact with the item the non-corrosiveness and moisture content of the cushioning materials is not critical (see Figure 5-7).

**5.22.3 Corner Pads/Blocks and Side Pads.** Corner pad/blocks are used where a minimum amount of material is required to cushion the item and a full floated item or pack is not justified because of the weight and size or fragility of the item. They are also used where the only requirement of the cushioning is separation of the item from the container. If the amount of cushioning material is too great for corner pads, then side pads may be used.

TO 1-1-700

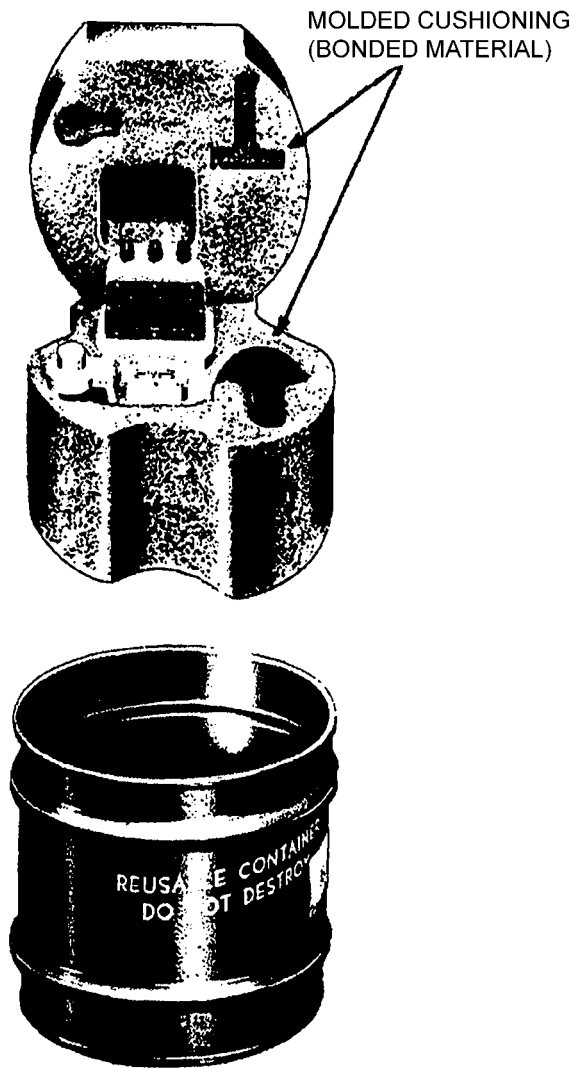

Figure 5-6. Floated Item

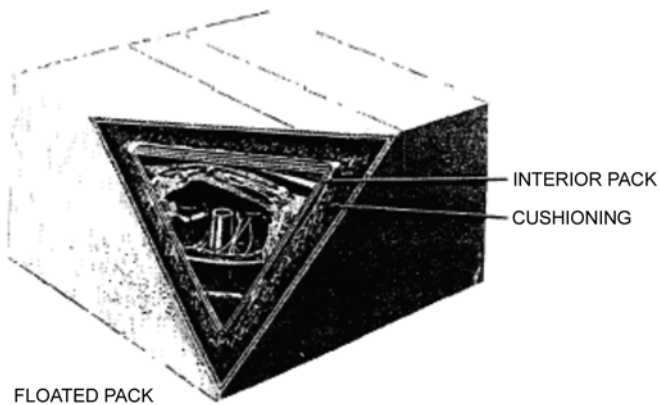

Figure 5-7. Floated Pack

5.22.4 Shock Mounts. The shock mount method is used to cushion very fragile items and sensitive instruments or mechanisms that can be damaged by shock and vibration, and the weight and size of the item may vary from light and small to heavy and large (see Figure 5-8). The shock mounts may consist of metal springs with damping, shear mounts, or corner blocks. This method may be accomplished in any one of four main ways:

- The item may be suspended directly by the means of shock mounts.
- The item may be blocked in a cradle and the cradle suspended by means of shock mounts.
- The item may be boxed in a unit container and the unit container suspended by means of shock mounts.
- The item may be boxed in an intermediate container and the intermediate container suspended by means of shock mounts.

### 5.23 CUSHIONING VS. DUNNAGE.

There is a profound difference between cushioning material and dunnage. Cushioning is an engineering application of a specific material thickness and bearing areas to protect against known forces whereas dunnage is the application of a unspecific material for minor protection.

5.23.1 Dunnage. Dunnage is the application of unspecific material to fill voids, to protect the finish from scratches or abrasions, or to prevent load shifting during transport. Dunnage may be loose-fill material. According to MIL-STD-2073-1 loose fill materials are prohibited in all military packages. Materials such as polyethylene, polyurethane, and polypropylene foams, flexible cellular plastic films (bubble wrap) and thin-sheet cellulose material are all acceptable for filling voids.

5.23.2 Cushioning. Cushioning materials can be used as dunnage but due to the cost, it is best to only use the cheaper dunnage materials for filling voids. Unless there is an excess or scrap cushioning materials available that can not be otherwise used, don't use them as dunnage.



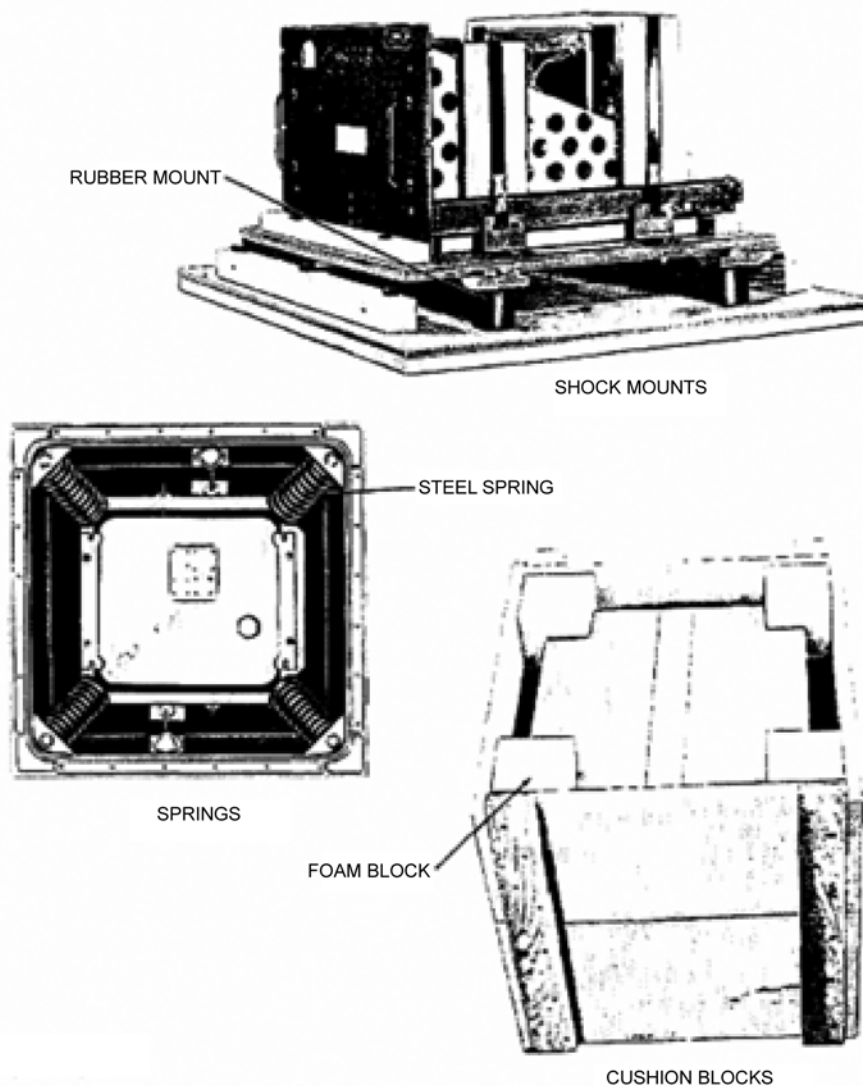

**Figure 5-8. Shock Isolators**

**5.23.3 Functions of Cushioning.** In order to properly utilize the many cushioning materials available, it is necessary to understand the functions of cushioning. The following is a list of items considered to be the most important functions of cushioning according to AFPAM(I) 24-237:

- **Control of Item Movement** - When applied properly, a cushioning controls the movement of items within the barrier or container while mitigating the effects of shock and vibration.
- **Protection of Fragile or Delicate Components** - Cushioning is applied to give protection to fragile or delicate items not permitted to be disassembled and packed separately and are otherwise a part of a rugged item.
- **Prevent Rupture of Barriers and Containers** - Cushioning is applied to items that may have sharp corners or projections which could puncture barriers or containers in which they are packed to prevent the entry of moisture or water by ensuring that waterproof or water vapor proof barriers are not rendered useless by such damage.
- **Distribute Forces** - Cushioning reduces the effects of impact shock to items by distributing the damaging forces over a large area.
- **Prevent Abrasion** - Cushioning protects against abrasion on items with highly finished surfaces which may be marred by blocking, strapping, or contact with other items in the container.

**TO 1-1-700**

- **Absorb Shocks** - Perhaps the most frequent and important function of cushioning is to absorb the energy resulting when a container is subjected to impact.

**5.24 CUSHIONING MATERIALS.**

Cushioning is made from many different materials and is used for different purposes. The following is a description of several types of cushioning materials, what they consist of and their intended use is as defined in AFPAM(I) 24-237:

**5.24.1 Bound Fiber (PPP-C-1120).** These materials consist of any suitable natural hair, vegetable fiber, or synthetic fiber bound with an elastic material. There are four types and two classes. The four types are variations of firmness, from soft to firm. Bound fiber materials are intended to protect items against vibration and impact shocks where resilient and water-resistant cushions are required. The classes are as follows:

- Class A - Water resistant, natural hair.
- Class B - Common class, not necessarily water-resistant.

**5.24.2 Cellulosic (A-A-1898).** This material may be made of any kind of cellulosic matter which will result in a product meeting the Commercial Item Description (CID). The matter used may be cotton, bonded fibers, natural fibers, or creped wadding. Its intended use is for packing lightweight, fragile items as a protection against abrasion. Grade I is specifically for absorbing liquids from containers broken in transit. The material is readily moldable, fairly resilient and furnished in three grades and three classes which are:

- Grade I - Water absorbent.
- Grade II - Water resistant.
- Grade III - Fire retardant, water resistant
- Class A - Low tensile strength
- Class B - Medium tensile strength
- Class C - High tensile strength

**5.24.3 Low Density Polypropylene Foam.** This material is supplied in rolls, tear-perforated rolls, or flat cuts, and is

made from a low density, resilient, unicellular (closed cell) polypropylene foam. The typical application of this material would be for surface protection of optical lenses, equipment with critical surfaces, electrical and electronic equipment, glassware, ceramics, and magnetic tape rolls.

**5.24.4 Solid and Corrugated Fiberboard.** Both solid and corrugated fiberboard are used in cushioning, but corrugated is more frequently used because it has greater cushioning value. The most common forms of fiberboard application are die-cuts, open end cells, trays, pleated pads, and flat pads (see Figure 5-9 and Figure 5-10).

**5.24.5 Solid Fiberboard (MIL-F-26862).** This fiberboard is made from cane, wood or other vegetable fiber. It is intended for use in packaging where a non-corrosive, fungus resistant material is needed to afford protection against vibration and impact damage during shipment and handling.

**5.24.6 Wrapping Paperboard (A-A-1051).** This is a paperboard composed of a corrugated sheet or a solid pulp sheet firmly cemented to a flat sheet of unbleached sulfate fiber paper backing. It has high compression low resilience, excellent damping, and some dusting. Its moisture content and absorption are high. The material is acidic and hence, has a high corrosion effect. Its performance in cold weather is poor, and it is neither fungus nor flame resistant.

**5.24.7 Flexible Open Cell Plastic Film (A-A-3129).** This material is intended for use within packages and available in sheets and rolls. It can be ordered in two types, two styles, two classes, and three grades with Grade B being static dissipative.

**5.24.8 Polystyrene Expanded, Resilient.** This is a resilient material of expanded polymers or copolymers of styrene for use in cushioning and packaging application. It is nonabrasive and fungus and mold resistant. It is used within packs to protect items from damage due to shock, vibrations, abrasion, and concentrated forces during handling and shipment. It is especially suited to packing problems where a high degree of energy absorption is required in a minimum space and with a minimum weight of cushioning.

**5.24.9 Closed Cell Foam Plank (A-A-59136), Polyethylene and Other Polyolefin.** These materials are intended for use within packages to protect items from damage due to shock, vibration, concentrated forces, contamination and abrasions during transit. Refer to MIL-HDBK-304 for specific application guidance.

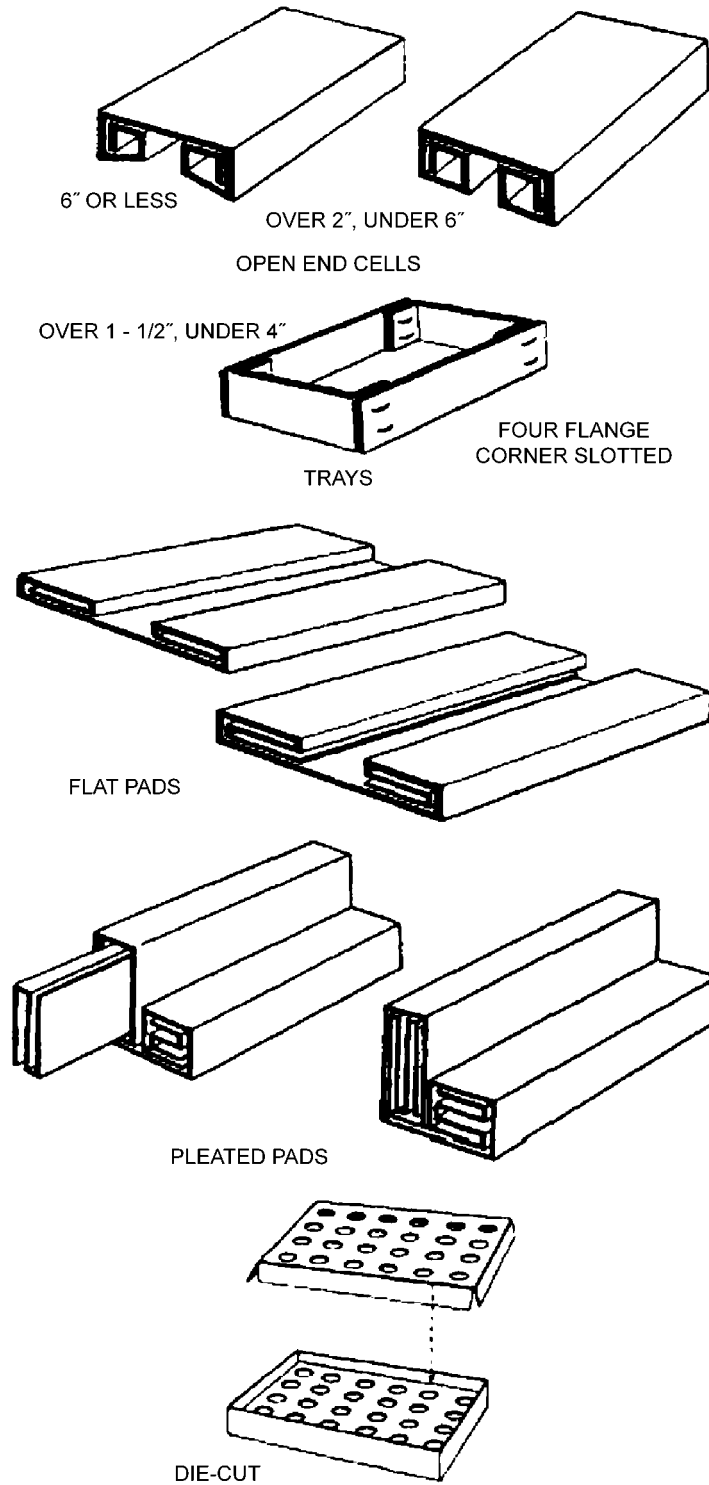

Figure 5-9. Examples of Fiberboard Die-Cuts, Open End Cell, Tray and Pads

TO 1-1-700

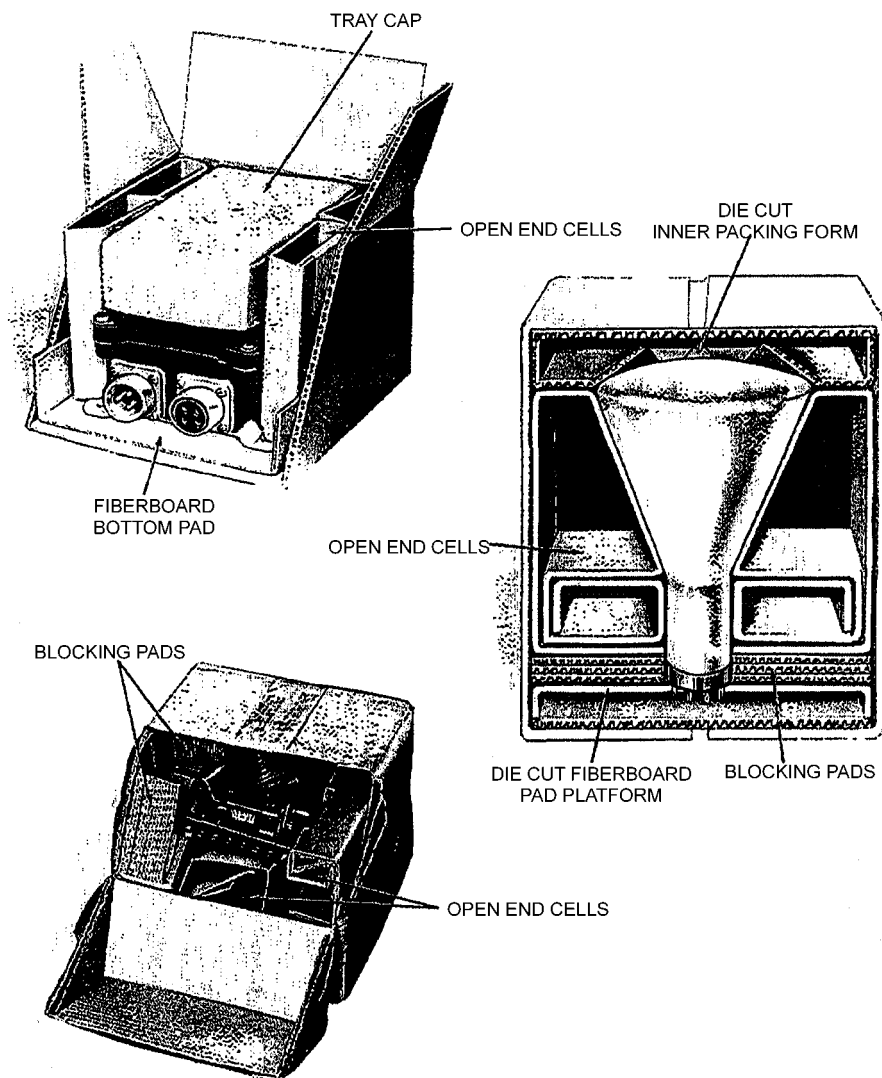

Figure 5-10. Application of Fiberboard Die-Cuts, Open End Cell, Tray and Pads

5.24.10 Rigid or Flexible Polyurethane Foam (MIL-PRF-26514). This material, furnished in rolls, sheets, or molded shapes, is available in two types, two classes, and three grades per type as follows:

Type I - Standard Foam	Type III - Antistatic Foam
Class 1 - Rigid	Class 1 - Rigid
Class 2 - Flexible	Class 2 - Flexible
Grade A - Blue	Grade A - Yellow
Grade B - Green	Grade B - Red
Grade C - Charcoal	Grade C - Brown

5.24.10.1 Materials covered by this specification (see Figure 5-11) are intended for use as cushioning and blocking braces in packages to protect equipment and items from damage by shocks or impacts incurred during shipment and handling.



**Figure 5-11. Polyurethane Foam**

5.24.11 Packaging (Flexible Closed Cell Plastic Film for Long Shipping Cycle Applications) (PPP-C-795). This specification establishes requirements for flexible closed cell, heat-sealable, non-corrosive, plastic film for use in cushioning and packaging applications. The cellular materials are intended for use within packages to protect items from damage due to shock, vibration, concentrated forces, contamination, and abrasion during handling and shipment. Refer to MIL-HDBK-304 for specific application guidance.

## 5.25 METHOD 20 - PRESERVATIVE COATING ONLY WITH GREASEPROOF WRAP.

Method 20 is one of the five basic methods of preservation and always requires the application of a preservative. See AFPAM(I) 24-237, Chapter 4, for application procedures.

5.25.1 Concept. Method 20 is accomplished by applying a preservative coating to the item. This protects the item against free water, salt spray, gases, and fumes which may be encountered during handling, shipping, and storage. The entire chemical protection afforded to the item is through the contact preservative.

5.25.2 Intended Use. Method 20 is used primarily on metal items whose characteristics allow ready application of a corrosion preventive compound by dipping, flow coating, slushing and spraying, flushing, brushing, or fogging.

5.25.3 Determining Factor. The determining factor in the selection of this method is whether or not the nature and design of the items permit application and removal, when necessary, of the compound without damage to the items. The protection of an item preserved by this method depends upon a clean and moisture-free surface. After the cleaning operation, items must be protected, particularly against moisture and deposits from fingerprints, until the preservative is applied.

## 5.26 METHOD 30 - WATERPROOF/WATERPROOF-GREASEPROOF PROTECTION.

See AFPAM(I) 24-237, Chapter 4, for application procedures.

5.26.1 Concept. Method 30 is accomplished by one of three sub-methods. Items protected in accordance with this method must be sealed within a waterproof or greaseproof-waterproof enclosure required by the specific sub-method. The three sub-methods under Method 30 concepts are:

- Method 31 - Waterproof bag, sealed.
- Method 32 - Container, waterproof bag, sealed.
- Method 33 - Greaseproof-waterproof bag, sealed.

5.26.2 Intended Use. This method is appropriate for almost any item that will fit into a bag; a rigid container other than all metal; or as long as only waterproof or greaseproof-waterproof protection is needed. If water/vapor proofness is a requirement, then choose either Method 40 or Method 50.

**TO 1-1-700****5.27 METHOD 40 - WATER VAPOR PROOF PROTECTION.**

See AFPAM(I) 24-237, Chapter 4, for application procedures.

**5.27.1 Concept.** This is a water vapor proof enclosure in which the items, with or without a preservative coating, are placed. The enclosure may be a rigid container or a water vapor proof barrier, depending on the method being developed. The sub-methods under Method 40 are:

- Method 41 - Water vapor proof bag, sealed.
- Method 42 - Container, water vapor proof bag, sealed, container.
- Method 43 - Floating water vapor proof bag, sealed.
- Method 44 - Rigid container (other than metal), sealed.
- Method 45 - Rigid metal container, sealed.

**5.27.2 Intended Use.** It is intended to afford protection to metallic and non-metallic items against deterioration caused by water or water vapor and by natural or industrial contaminants and pollutants.

**5.27.3 Critical Parts.** When critical functioning metal surface parts and equipment require close tolerances, Method 40 can be supplemented with contact preservatives.

**5.27.4 Usage Without Contact Preservation.** This method was originally intended to prevent corrosion on metal parts, but can also be used without a contact preservative to keep fabric, paper, plastic, and other non-metallic items clean and dry during shipment and storage.

**5.28 METHOD 50 - WATER VAPOR PROOF PROTECTION WITH DESICCANT.**

See AFPAM(I) 24-237, Chapter 4, for application procedures.

**5.28.1 Concept.** Items protected in accordance with this method shall be sealed in a water vapor proof enclosure with activated desiccant as required for the specific sub-method of

this group. A humidity indicator should be use with the packs unless otherwise stated in the contract or order.

**5.28.2 Sub-Method Requirements.** There are five sub-methods of this method which can be used. The following general requirements apply to all sub-methods:

- Items shall be sealed in a water vapor proof enclosure with activated desiccant.
- Unit packs shall include a humidity indicator.
- Methods 50 labels will be applied to unit packs (see Figure 5-8).
- Items shall be cushioned as required to mitigate shock, thereby preventing physical and functional damage to the item.
- When bags are used, the sealed edge of the bag that would normally be opened for item inspection shall be of sufficient surface area to permit two subsequent resealing after item inspection, unless otherwise specified.

**5.28.3 Sub-Methods of Method 50.** The five sub-methods of Method 50 are:

- Method 51 - Water vapor proof bag, sealed.
- Method 52 - Container, water vapor proof bag, sealed, container.
- Method 53 - Floating water vapor proof bag, sealed.
- Method 54 - Rigid Container (other than metal), sealed.
- Method 55 - Rigid metal container, sealed.

**5.28.4 Intended Use.** This method is used for items of a highly critical nature which require the highest degree of protection from damage by the effects of water vapor. It is applicable to mechanical or electrical items including assemblies with functional components which, because of their nature, cannot be treated with a preservative. This method is not used on any item where the withdrawal of moisture would cause damage to the item.



## CHAPTER 6

### MOISTURE AND FUNGUS PROOFING

#### 6.1 GENERAL.

The following moisture and fungus-proofing requirements are furnished to enable inspecting personnel to determine quality and acceptability of repaired equipment. Consult Appendixes A and B of TO 1-1-691 for information on materials and equipment required for these procedures.

#### 6.2 DETAILED REQUIREMENTS.

The following materials will be treated as specified in this manual prior to assembly on electronic equipment and will need no additional varnish coverage.

**6.2.1 Leather.** Examine leather items such as bags, cases, belts, etc., for wear, torn seams, stains, fungi, etc. Leather is highly prone to attack by mold, mildew, and fungus.

**6.2.1.1** Repair all torn seams with MIL-T-713, Type N, Class 3 wax impregnated twine mildew proofed per MIL-T-3530, Type I, Class 2. Use No. 301 lock stitches per ASTM-D-6193.

**6.2.1.2** Remove paint (lacquer and enamel), ink, or other similar marking materials applied by field units for identification purposes as follows:



ASTM D 329 (PART NO. O-A-51), ACETONE 11

- a. Dampen a cloth with ASTM D 329 (O-A-51) acetone and lay it on the area from which the marking materials are to be removed.
- b. Allow the dampened cloth to remain in contact with the area until marking material has softened.
- c. Remove softened marking material by scraping, rubbing or brushing with a toothbrush with medium stiffness bristles. Clean leather items with a mild soap and water solution at a temperature not to exceed 100 °F (38 °C) applied with a cloth followed by brushing with a toothbrush with medium stiffness bristles to remove any remaining dirt.

**6.2.1.3** Rinse with clean water at a temperature between 75 °F (24 °C) and 100 °F (38 °C) applied with a cloth.

**6.2.1.4** Wipe off all standing water from the leather surface and allow it to air dry for 40 minutes if subsequent treatment is required, treat with Type I mildew preventive leather dressing compound.



O-L-164, DRESSING, LEATHER

55

#### NOTE

O-L-164, Type I Leather Dressing compound is available through GSA in a 5 gallon can under NSN 8030-00-221-0665.

- a. Mix one part of O-L-164, Type I leather dressing compound by volume into 5 parts by volume of clean water. Preferably, application will be by immersing leather items in the solution and stirring and/or tumbling them for 10 minutes. When immersion is impractical due to inclusion of critical parts on a leather item, application of solution may be made with a soft bristled brush, felt dauber or cloth.
- b. Allow treated leather to dry in open air.



Under no condition shall olive drab paint be used to paint canvas or duck items.

**6.2.2 Canvas and/or Duck.** Examine canvas or duck items for wear, torn seams, stains, fungi, etc. Those considered to be still serviceable will be processed as follows:

- a. Repair all torn seams with either 10/3 or 12/4 cotton thread conforming to Commercial Item Description (CID) A-A-52094, Type II.

#### NOTE

These threads are available through the Air Force supply system in 16 oz. tubes and olive drab in color under NSN 8310-00-262-2782 for the 10/3 thread and NSN 8310-00-197-7757 for the 12/4 thread.

- b. Wash items in a washing machine or other device in which canvas and/or duck items are tumbled in a solu-

## TO 1-1-700

tion of soap/detergent (any commercial dishwasher type) and water at a temperature of 100 °F (38 °C) to 140 °F (60 °C). Use of bleach is prohibited. Any residual dirt after this washing may be removed by scrubbing with a brush having medium stiffness bristles only. Rinse with clean water at a temperature between 75 °F (24 °C) and 100 °F (38 °C), and allow items to dry in open air.



O-E-760, ALCOHOL, DENATURED ETHYL 54



DIHYDROXYDICHLORODIPHENYL METHANE 14

- c. To provide fungus resistance, immerse canvas and/or duck in a 2% solution by volume of dihydroxydichlorodiphenyl methane in O-E-760, Type III denatured ethyl alcohol until all bubbling ceases; remove the item from the solution; allow it to dry in open air.
- d. To provide moisture repellency, immerse the item that has already been treated for fungus resistance in an aqueous solution of Aridex L mixed per the manufacturer's instructions, and allow it to remain in solution until thoroughly impregnated. Allow items to drain at room temperature and dry with hot air at a temperature not exceeding 250 °F (121 °C).

## NOTE

- Dihydroxydichlorodiphenylmethane fungus repellent may be procured commercially from the Sindar Corp; New York, NY.
- Aridex L moisture repellent may be procured commercially from the Aridex Co; New York, NY.
- O-E 760, Type III denatured ethyl alcohol is available through the Air Force supply system in a 1 gallon can under NSN 6810-00-543-7415.
- To prevent shrinkage, a drying frame may be used on canvas cases during these procedures.

6.2.3 **Cork.** Cork is notorious for absorbing moisture and causing crevice corrosion in faying surface areas. If at all pos-

sible, cork items should be replaced with like sized items fabricated from an appropriate type of closed cell rubber material. If this can not be done, the cork material shall at least be treated to make it fungus resistant.



O-E-760, ALCOHOL, DENATURED ETHYL 54



SALICYLANILIDE 63

6.2.3.1 To provide fungus resistance for cork items, immerse them in a 2% solution by volume of salicylanilide in O-E-760, Type III denatured ethyl alcohol until all bubbling ceases; allow them to dry in open air.

6.2.4 **Paper.** Paper hermetically sealed within parts or bonded between sheets of plastic material need not be treated.



ASTM D 3955 (MIL-V-173), VANISH, ELECTRICAL INSULATING 12

- a. Brush or spray mounted paper labels and approximately 1/2 inch of mounting surface immediately adjacent to the label edges with ASTM D 3955 (MIL-V-173) electrical insulating (moisture and fungus resistant) varnish.



SALICYLANILIDE 63



O-E-760, ALCOHOL, DENATURED ETHYL 54

- b. Immerse unmounted paper charts, diagrams, speakers, cones, etc. in a 2% solution by volume of salicylanilide in O-E-760, Type III denatured ethyl alcohol; allow them to dry in open air.



ASTM D 3955 (MIL-V-173), VANISH, ELECTRICAL INSULATING

12

- c. Spray or brush decalcomanias used on interior surfaces with ASTM D 3955 (MIL-V-173) electrical insulating (moisture and fungus resistant) varnish.

#### NOTE

ASTM D 3955 (MIL-V-173) electrical insulating (moisture and fungus resistant) varnish is available through the Air Force supply system in a 16 oz. aerosol can under NSN 5970-00-832-6950 and in a 1 gallon can under NSN 5970-00-285-0269.

#### 6.2.5 Webbing. Examine webbing.

- a. Wash items in a washing machine or other device in which webbing items are tumbled in a solution of soap/detergent (any commercial dishwasher type) and water at a temperature of 100 °F (38 °C) to 140 °F (60 °C). Use of bleach is prohibited. Any residual dirt after this washing may be removed by scrubbing with a brush having medium stiffness bristles only. Rinse with clean water at a temperature between 75 °F (24 °C) and 100 °F (38 °C), and allow items to dry in open air.



DIHYDROXYDICHLORODIPHENYL METHANE

14



O-E-760, ALCOHOL, DENATURED ETHYL

54



Re-dyeing or painting webbing with enamels is prohibited as this can damage the webbing.

- b. To provide fungus resistance, immerse webbing in a 2% solution by volume of dihydroxydichlorodiphenyl methane in O-E-760, Type III denatured ethyl alcohol until all bubbling ceases; remove the item from the solution; allow it to dry in open air.

6.2.6 Felt. Examine felt for wear, torn seams, stains, fungi, etc. Felt items considered to be still serviceable will be processed as follows:



O-E-760, ALCOHOL, DENATURED ETHYL

54



SALICYLANILIDE

63

#### NOTE

The foregoing treatment may be eliminated if it can be ascertained that felt was properly treated prior to procurement.

- a. To provide fungus resistance for felt items, immerse them in a 2% solution by volume of salicylanilide and denatured ethyl alcohol until bubbling ceases.
- b. Remove excess solution by squeezing felt items through a wringer such as an electric or hand operated household washing machine wringer or equivalent.
- c. Dry the felt items in open air.

6.2.7 Treatment of Metal Parts. Metal parts on any of the leather, canvas or duck, cork, paper, webbing, or felt items shall be cleaned after treatments specified above have been applied. The cleaning procedures are as follows:



TT-I-735, ALCOHOL, ISOPROPYL

65



TT-N-95, NAPHTHA, ALIPHATIC

66

- a. Clean any oil, grease, or residual treatment from the metal parts by wiping with a soft cloth wet with a 50/50 by volume mixture of TT-N-95 aliphatic naphtha and TT-I-735 isopropyl alcohol, and dry them by wiping with a clean, dry cloth.
- b. Surface of metal parts shall be finished to meet requirements stated in the equipment system specific maintenance manual.

**TO 1-1-700**

nance manual and/or the item specifications and drawings.

### 6.3 MOISTURE AND FUNGUS RESISTANT VARNISH TREATMENT OF GROUND COMMUNICATIONS, ELECTRONIC, METEOROLOGICAL (C-E-M) AND ASSOCIATED ELECTRICAL EQUIPMENT.

6.3.1 Retreatment Criteria. Equipment shall be examined and retreated if its condition can be classified under one of the following criteria:

6.3.1.1 The equipment shows evidence of any type of deterioration whether previously treated or not.

6.3.1.2 During the process of repair, the equipment has been subjected to abrasion by sanding or blasting of any nature.

6.3.1.3 The presence of white powdery oxide deposits on aluminum alloy or cadmium-plated parts that interfere with proper operation of the equipment thus requiring some disassembly or overhaul.

**NOTE**

The presence of these deposits in itself will not constitute reason for disassembly or overhaul unless they specifically interfere with proper operation of the equipment.



MIL-DTL-81706 (ALODINE), COATING, CHEMICAL CONVERSION

23

6.3.1.4 The presence of white powdery oxide deposits on aluminum alloy or cadmium-plated parts that do not interfere with proper operation of the equipment requires only brushing off accessible oxide deposits with a non-metallic (nonabrasive) stiff bristle brush and treatment of affected surfaces with MIL-DTL-81706 (MIL-DTL-5541), Class 1A, Form VI, Method D solution (Touch-N-Prep/TNP pen method) per Section II of Chapter 5 in TO 1-1-691.

6.3.2 Cleaning.



MIL-P-85891, GRAIN, ABRASIVE

36

**WARNING**

Open air, glove box, and walk-in booth operations will be evaluated by the safety officer and the bioenvironmental engineer to ensure personnel safety.

**CAUTION**

- The use of sand, carborundum, aluminum oxide, or steel grit should be avoided since abrasive material of this type may enter moving parts and cause jamming or excessive wear. Any conductive types of these materials remaining in equipment may also impair its electrical operation.
- When plastic media is used, use only MIL-P-85891, Type V as all other types are too hard and can damage the substrate.

**NOTE**

A-A-1722, Type II black walnut shells are available through Air Force supply in a 50 lb. Bag under NSN 5650-00-050-1094, and MIL-P-85891, Type V plastic media is available through Air Force supply in a 250 lb. bag under NSN 5650-01-327-8461.

6.3.2.1 Varnish Treatment Removal. Remove old existing varnish by abrasive blasting with abrasive material such as ground black walnut shells conforming to A-A-1722, Type II or plastic media conforming to MIL-P-85891, Type V per procedures in Chapter 2 of TO 1-1-8 for process guidelines.

**WARNING**

Use of compressed air for cleaning can create airborne particles which may enter the eyes and cause serious injury. Effective chip guarding including eye protection is required.

**CAUTION**

Excessive air pressures or a concentrated blast stream can damage insulation and delicate electronic parts. This will be avoided during the cleaning process. Air pressure for cleaning shall be limited to a pressure of 30 PSI at the nozzle. The nozzle diameter shall be 1/4 inch minimum.

6.3.2.2 Final Cleaning and Debris Removal. Remove all loose dirt, dust, abrasive debris, and any grease or oil as follows:

- a. After first directing blast of air at floor to clear any condensed moisture from the air line, blow air over all surfaces or use a commercial grade wet/dry vacuum to remove all loose dirt, dust, and abrasive debris.



TT-N-95, NAPHTHA, ALIPHATIC

66



TT-I-735, ALCOHOL, ISOPROPYL

65

- b. Clean any oil, grease, or residual treatment from the metal parts by wiping with a soft cloth wet with a 50/50 by volume mixture of TT-N-95 Aliphatic Naphtha and TT-I-735 Isopropyl Alcohol, and dry them by wiping with a clean, dry cloth.
- c. Clean any remaining visible resin deposits from areas where soldering operations will be conducted by scraping or chipping.

#### 6.4 PREPARATION FOR RETREATMENT.

After all repairs and refinishing in accordance with Chapters 7 and 8 of this manual and TOs 1-1-8, 1-1-689-series, 1-1-691 31-1-69, 31-1-75, 35E4-1-162, and all applicable equipment system specific maintenance manuals have been completed, reassemble equipment as far as practicable while still allowing complete coverage of required areas. Sometimes, it is better to coat subassemblies with varnish prior to assembly to provide better coverage and/or aid in application.

6.4.1 **Masking.** Mask all surfaces or parts where such application of the varnish coating will interfere with operation or performance of equipment. The following are examples of surfaces which are NOT to be treated by the method specified herein:

6.4.1.1 Contact portion of binding posts, connectors, fuses, jacks, keys, plugs, relay, sockets, switches, test points, and variable capacitors.

6.4.1.2 Surfaces which rub together for electrical or magnetic contact such as those in contact fingers, potentiometers, shafts, shields, variable autotransformers, and relays.

6.4.1.3 Bearing surfaces, including bearing surfaces of gas-kets and sliding surfaces.

6.4.1.4 Bearings, gear teeth, and gear trains of assemblies.

6.4.1.5 Screw threads and screw adjustments, normally moved in process of operation or adjustments.

6.4.1.6 Springs, except at base of pile up.

6.4.1.7 Surfaces whose operating temperatures exceed 302 °F (150 °C) or will cause carbonization or smoking.

6.4.1.8 Transparent plastic parts.

6.4.1.9 Windows, lenses, etc.

6.4.1.10 Cable with plastic or rubber insulation.

6.4.1.11 Capacitors - variable, air, ceramic, or micadielectric types.

6.4.1.12 Ceramic insulators subject to 600 V operating voltage, where danger of flashover exists.

6.4.1.13 Materials when used for their specific ARC-RESISTANT properties and classified as ARC-RESISTANT in applicable material specifications.

6.4.1.14 Painted, lacquered, or varnished exterior surfaces.

6.4.1.15 Pins, mating surfaces, and threads of plugs, plug-connectors, tube sockets, etc.

6.4.1.16 Resistors where heat dissipation is undesirably affected and where coating material may become carbonized.

6.4.1.17 Rotating equipments, dynamotors, generators, motors, etc., however, their associated electronic components such as filter units, etc., shall be treated according to requirements specified herein.

6.4.1.18 Wave guides and R.F. plumbing, in particular on mating flange areas, where the varnish coating may be detrimental to proper functioning, cause an improper VSWR to develop, and/or attenuate signals to a greater than allowable degree.

6.4.1.19 The exterior, visible outside portions of indicating instruments and control boxes.

6.4.2 **Drying of Equipment.** Apply the varnish coating only on dry surfaces and never on wet or damp surfaces. Dry equipment by heating it to 120 °F to 140 °F (49 °C to 60 °C) for a minimum period of 1/2 hour but no longer than 3 hours to substantially dehydrate equipment, and allow it to cool below 100 °F (38 °C) prior to varnish coating application.

6.4.3 **Methods of Treatment.** Use the following techniques and criteria for application of the varnish coating:

**TO 1-1-700**

- a. Apply varnish to either totally assembled equipment or to subassemblies prior to installation in their next higher assembly; whichever will ensure that all fixed electrical connections are adequately coated. Parts which require treatment and cannot be properly coated after assembly into equipment will be coated prior to assembly.



■ **ASTM D 3955 (MIL-V-173), VARNISH, ELECTRICAL INSULATING** 12

- b. Apply varnish by spraying, dipping, brushing, or any combination thereof in such a manner that dried film will provide complete coverage and have a clear smooth finish free from defects such as bubbles, wrinkles, filaments, or dry spray dust. Where practicable, the thickness of dried coating shall be at least 0.002 inches (2 mils).

**6.4.4 Preparing Coating Material for Application.** Use these guidelines when preparing the varnish coating materials for application:



■ **ASTM D 3955 (MIL-V-173), VARNISH, ELECTRICAL INSULATING** 12

- a. Choose an appropriate coating material that conforms to ASTM D 3955 (MIL-V-173).



■ **A-A-3007, THINNER, PHENOLFORMALDEHYDE AND MEDIUM OIL AND STYRENATED ALKYD PAINTS AND VARNISHES** 1

- b. If thinning is required, thinner conforming to A-A-3007 shall be used. Mixing of the thinner with the varnish shall be per the varnish manufacturer's instructions.
- c. The varnish when ready for application shall contain 50 percent or more by weight of nonvolatile matter.

**NOTE**

ASTM D 3955 (MIL-V-173), Moisture and Fungus Resistant Varnish, and A-A-3007, Thinner, are both available through the Air Force supply system. A-A-

3007, Thinner, can be procured in a 1 quart can under NSN 8010-00-441-5938 and a 1 gallon can under NSN 8010-00-441-5940. ASTM D 3955 (MIL-V-173), Moisture and Fungus Resistant Varnish, can be procured in a 16 oz. aerosol can under NSN 5970-00-832-6950, a 1 quart can under NSN 8010-00-180-6343, and a 1 gallon can under NSN 5970-00-285-0271.

**6.4.5 Coverage.** Apply coating material thoroughly and completely over all surfaces, circuit elements, resistors, capacitors, coils, etc., all surfaces supporting circuit elements, interconnecting wiring and connections unless such application will interfere with operating performance of equipment. The following are examples of parts which normally require treatment in complete assembly; however, the part need not be treated if specifically exempted by applicable repair standard, if marked as required by paragraph 6.4.9 or if exempted under paragraph 6.4.6.

**6.4.5.1 Cables, cordage, braid-covered cables, cable forms, lacing cord, wire, etc., (i.e., those inside equipment and not normally fixed in operation).**

**6.4.5.2 Capacitors, fixed under 600-volts operating, must be treated after assembly.**

**6.4.5.3 Chassis, bottom, and top, unless finished in accordance with requirements of Chapter 7.**

**6.4.5.4 Chokes.**

**6.4.5.5 Coils.**

**6.4.5.6 Metals, joints between dissimilar metals and unvarnished or unpainted metallic surfaces, including shield cans, cases, and covers, unless finished in accordance with requirements of REP-1007.**

**6.4.5.7 Paper labels and decalcomanias.**

**6.4.5.8 Pile-up portions of jacks, relays, switches, etc.**

**6.4.5.9 Resistors, fixed, except hermetical types, all others must be treated after assembly.**

**6.4.5.10 Tube sockets, except contacts.**

**6.4.5.11 Soldered joints, including adjacent wire insulation and terminal boards.**

**6.4.5.12 Toggle switches.**

**6.4.5.13 Terminal boards.**



6.4.5.14 Terminals, screw lugs, and soldered connections, after making connections.

#### 6.4.6 Exemptions.

6.4.6.1 The following parts need not be coated, however, no precaution need be taken to prevent coverage, except that dripping thereon shall be prevented.

6.4.6.1.1 Cable wire, braids, and jackets whose outside surface is of rubber, synthetic rubber, or Vinylite type composition, not flexed in normal operation.

6.4.6.1.2 Materials such as nylon, cellulose-acetate rayon glass, natural or synthetic rubber; this is not applicable to cable and wire.

6.4.6.1.3 Painted, lacquered, varnished, or surface treated metal such as chromated zinc or cadmium and anodized aluminum, interior surfaces.

6.4.6.1.4 Parts made of or plated with chromium, gold, nickel, rhodium, or stainless steel.

6.4.6.1.5 Shields for coils, electron tubes, transformers, etc., and interior surfaces of the shields.

6.4.6.1.6 Small surfaces which were covered to affect required masking; this is not applicable to solder joints.

6.4.6.1.7 Tubes, electron, and avoid direct application to envelopes.

6.4.6.2 The following parts and materials shall not be treated in accordance with this process except as specified herein, but shall be obtained with an approved fungicidal treatment or be given a fungicidal treatment in accordance with other processes.

6.4.6.2.1 Cables, cordage, cords, braided cable, etc., which are flexed in normal operation.

6.4.6.2.2 Instruments, electrical, indicating, treat soldered connections only during repair operations of the meter.

6.4.6.2.3 Lacing cord, but no precaution need be taken to prevent overall spray.

6.4.6.2.4 Materials such as canvas, duck, cork, felt, wool or hair fiber, leather, rope, wood, etc.

6.4.6.2.5 Wave guides.

#### **NOTE**

Rotating equipment, such as dynamotors, generators, motors, power units, and engines, will be impregnated with a varnish conforming to Grade CB of MIL-I-24092.

#### 6.4.7 Final Drying of Coated Materials.

6.4.7.1 Prior to packaging, coating shall be dried hard on metal surfaces and on other surfaces, coating shall not be tacky.

6.4.7.2 Coated assemblies shall be force-dried at a temperature not exceeding 60 °C (140 °F). Care shall be taken to ensure sufficient drying to prevent presence of solvent vapors in any enclosure.

6.4.7.3 Force drying shall be accomplished for a minimum period of 1/2 hour and not exceeding 3 hours.

6.4.8 Adjusting and Final Testing. (After 24 hours of air drying.) After treatment, the equipment or individual assembly shall be adjusted and aligned for optimum operating characteristics and, wherever film is broken during alignment. Breaks will be retouched.

6.4.9 Marking of Treated Equipment. Each unit of equipment which has been treated and each treated plug-in assembly as well as all cases and containers in which they are packed for shipment, will bear a permanent and legible marking reading MFP. Where any equipment is composed of major components or assemblies each of these may be individually marked.

#### 6.4.10 Determination of Coverage.

6.4.10.1 Coverage will be inspected for compliance with requirements of this process.

6.4.10.2 In general, coating will present a glossy appearance when viewed under ordinary light.

6.4.10.3 Since varnish coating material is inherently fluorescent, inspection of treated equipment will be made under an ultraviolet light.

6.4.10.4 The extent of coverage will be determined by appearance of fluorescence.



## CHAPTER 7

# PREVENTATIVE MAINTENANCE AND REFINISHING ON STRUCTURAL COMPONENTS

### 7.1 PURPOSE.

This technical manual is intended for use by depot and field level maintenance personnel in the requirement and determination of the quality and acceptability of work performed for cleaning, corrosion prevention and control, and repair of Ground Communication, Electronics, and Meteorological Equipment (C-E-M) and its protective shelters, vans, and radomes.

**7.1.1 Interpretation.** Nothing in this technical manual shall be interpreted as specifying the extent of repair or refinish except when noted defects affect the operational characteristics or tolerances of a piece of equipment.

**7.1.2 Technical Manuals.** All activities involved with cleaning, corrosion prevention and control, and repair of C-E-M equipment or inspection and/or testing of the repaired or refurbished equipment shall use this technical manual in conjunction with TOs 1-1-8, 1-1-689-series, 1-1-691, and equipment system specific maintenance manuals as a guide for cleaning, corrosion prevention and control, and refinishing/touchup operations.

### 7.2 CORROSION PROTECTION.

All structural metals will corrode to some extent in a natural environment. When a metal corrodes, the metal atoms lose electrons and become positively charged metal ions in the electrolyte. In solution, the positively charged metal ions can combine with negatively charged ions to form corrosion products, such as metallic chlorides, oxides, hydroxides, sulfides, etc.

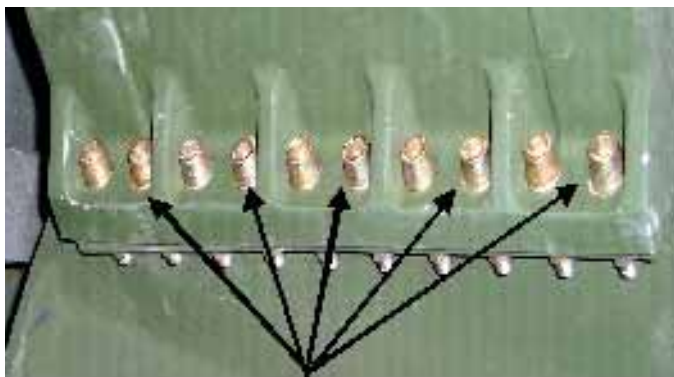

**Figure 7-1. Corroded Hardware**

### 7.3 PREVENTATIVE MAINTENANCE.

As directed by AFI 21-116, the prevention and control of corrosion communications equipment is a command responsibility. Each command must place special emphasis on the importance of the corrosion control program and lend its full support to ensure that control receives sufficient priority to be accomplished along with other maintenance.

**7.3.1 Cleaning.** Maintain the exterior and interior of equipment and components such that they will be free of grease, dirt, dust, corrosion, fungus, mold, and any other extraneous/foreign matter. Use only those cleaning processes that have no harmful or damaging effect on the equipment being cleaned. Observe all the warnings, cautions, and notes listed below as well as in other published specific cleaning procedures during all cleaning operations.



- Do not use unauthorized cleaners. Although other commercial cleaners may appear to perform as well as, or better than approved products, these materials may be corrosive to metal alloys used in C-E-M equipment. They can accelerate degradation of non-metallic materials causing material failures, which may result in corrosion of surrounding metals, electrical shorts, crazing, and/or mechanical/electrical failure.
- Ozone depleting substances (ODS) such as, but not limited to, 1,1,1 trichloroethane (MIL-T-81533) and trichlorotrifluoroethane (MIL-C-81302) solvents, as well as products containing them, are still used in some maintenance processes. Alternate materials continue to be identified; and wherever possible, specifications are being changed to eliminate their use automatically. Some products that have been reformulated are now flammable, so pay close attention to all CAUTION/WARNING labels on solvents and solvent-based products as well as in their MSDSs.

**NOTE**

- Authorized cleaning agents and equipment are listed in Table 7-1; Chapter 2 of TO 1-1-689-3; Chapter 3 of TO 1-1-691; Appendix A of TO 1-1-691 and Table 2-3 of TO 1-1-689-5. Order materials and equipment by NSN from the lists in these appendixes through normal Air Force supply channels, by local purchase from vendors listed on the most current Qualified Products List (QPL) of a listed specification, or by vendor part number listed in these appendixes for an authorized non-specification material.
- Specification QPLs are the responsibility of the authority for the specification. For information on and most current revision of the many cleaning and corrosion prevention and control material and process related specifications as well as the most current QPLs for those specifications having a QPL are available from the ASSIST Quick Search, website <http://assist.daps.dla.mil/quicksearch/>.

7.3.1.1 **Cleaning Compounds.** Cleaning compounds work by dissolving soluble soils, emulsifying oily soils, and suspending solid soils. There are several types of cleaning compounds, each of which cleans a surface using one or more of these mechanisms.

7.3.1.1.1 **Alkaline Cleaners.** Many alkaline cleaners are not authorized for cleaning Air Force communications equipment because they are not compatible with insulation on electrical wiring and related equipment.

7.3.1.1.1.1 Cleaning compounds conforming to MIL-PRF-87937 and MIL-PRF-85570 and that are listed on the QPL for

each specification have been tested and proven compatible with polyamide insulation. Types I and IV of MIL-PRF-87937 and Types I and II of MIL-PRF-85570 all contain detergents and foaming agents and work the same way as any detergent solution.

7.3.1.1.1.2 Type I cleaners of both specifications contain solvents and are more effective for removal of heavy oils and greases such as wire rope lubricant, but they cannot be used in poorly ventilated areas due to their solvent content. Type IV of MIL-PRF-87937 and Type II of MIL-PRF-85570 are all good general cleaners for removal of dirt, grime, light oils, and hydraulic fluid and they are usable in confined areas such as vans, shelters, and enclosed radar antennas as they contain no solvents.

7.3.1.1.2 MIL-PRF-87937, Type I (Terpene Solvent Based) and MIL-PRF-85570, Type I (Aromatic Solvent Based). These cleaners are water dilutable and biodegradable materials and are very good general cleaners for washing components and support equipment. However, since they contain solvents, environmental and waste disposal factors need to be considered prior to use. Since MIL-PRF-87937, Type I materials contain terpenes which are potentially corrosive if entrapped and not completely removed, their use may be restrictive on some C-E-M equipment.

7.3.1.1.3 MIL-PRF-87937, Type IV and MIL-PRF-85570, Type II. These cleaners are water dilutable and biodegradable materials and are the primary cleaners for washing the exterior of support equipment (SE). They are excellent materials for removing light to medium soils (greases, oils, grime, etc.) from almost all surfaces.

7.3.1.1.4 For the areas in which these and other cleaners are used refer to Table 7-1.

Table 7-1. Cleaning of Specific Areas and Components



Area or Component	Type of Contaminant	Cleaning Agent	Mixing Directions and Nomenclature	Cleaning Procedures
				
		MIL-PRF-680 AND A-A-59601, SOLVENT, DEGREASING, TYPE II AND III	45	
				
		MIL-PRF-85570, CLEANING COMPOUND, AIRCRAFT	51	
				
		MIL-PRF-87937, CLEANING COMPOUND, AIRCRAFT	52	
<b>NOTE</b>				
<ul style="list-style-type: none"> <li>• Cleaning procedures are listed in this table. Ordering information for approved materials can be found in Appendix A and ordering information for approved equipment can be found in Appendix B of TO 1-1-691.</li> <li>• Use of hot water (120 to 140 °F/49 to 60 °C) for rinsing during CEM washing operations is strongly recommended as it provides much more efficient rinsing and is known to reduce man-hours for cleaning operations by approximately 20%.</li> </ul>				
EXTERIOR SURFACES, PAINTED	Light Soils (dirt, dust, mud, salt, loose soot)	MIL-PRF-87937, Type IV or MIL-PRF-85570, Type II or MIL-PRF-85570, Type I	1 part cleaner in 9 parts water  1 part cleaner in 16 parts water	Apply cleaner solution with foam generator, spray, sponge, soft brush, or cloth. Scrub, then rinse with fresh water, and dry. MIL-PRF-87937, Type I materials contain terpenes. Aircraft SPD and/or missile or equipment SPM restrictions may apply. Consult system specific maintenance manuals.
	Moderate Soils (hydraulic fluids, lube soils, light preservatives)	MIL-PRF-87937, Type IV or MIL-PRF-85570, Type II or MIL-PRF-85570, Type I	1 part cleaner in 4 parts water  1 part cleaner in 9 parts water	Apply cleaner solution with foam generator, spray, sponge, soft brush, or cloth. Rub gently with a circular motion for up to 1 minute. Rinse with fresh water and dry. Use of MIL-PRF-87937, Type I is subject to restrictions noted above.
	Heavy Soils (carbonized oil, aged preservatives, grease, gun blast and exhaust deposits)	MIL-PRF-87937, Type III or MIL-PRF-85570, Type V	Undiluted	Spray or brush on cleaner. After 5 to 15 minutes, brush and rinse thoroughly.

Table 7-1. Cleaning of Specific Areas and Components - Continued







Area or Component	Type of Contaminant	Cleaning Agent	Mixing Directions and Nomenclature	Cleaning Procedures
				
		MIL-PRF-680 AND A-A-59601, SOLVENT, DEGREASING, TYPE II AND III		45
				
		MIL-PRF-85570, CLEANING COMPOUND, AIRCRAFT		51
				
		MIL-PRF-87937, CLEANING COMPOUND, AIRCRAFT		52
EXTERIOR SURFACES, PAINTED - Continued		<p>or</p> <p>A-A-59601 or MIL-PRF-680, Type and</p> <p>CCC-C-440, Type II or III, Class 1 or A-A-2522, Grad A or AMS 3819, Class 1 Grade A and</p> <p>MIL-PRF-87937 or MIL-PRF-85570, Type I</p> <p>or</p> <p>MIL-PRF-87937, Type IV or MIL-PRF-85570, Type II</p> <p>MIL-PRF-87937, Type IV</p> <p>MIL-PRF-85570, Type III, IV or V</p> <p>MIL-PRF-85570, Type IV</p>	<p>Degreasing Solvent Undiluted</p> <p>Cotton Cheese-cloth (Unbleached) White Cotton cloth, White Cleaning Cloth</p> <p>1 part cleaner in 4 parts water</p> <p>1 part cleaner in 4 parts water</p> <p>Undiluted</p> <p>Undiluted</p>	<p>Pre-clean by wiping or brushing with A-A-59601 or MIL-PRF-680, Type II solvent, then apply cleaner solution with foam generator, spray sponge, or cloth. Allow the cleaner to dwell for up to 1 minute without scrubbing then scrub for up to a minute. Rinse thoroughly, then dry. Do not allow cleaning solution to dry on surfaces or streaking will occur. Use of MIL-PRF-87937, Type I is subject to restrictions noted above.</p> <p>Apply cleaner with a damp cloth. Rub with a circular motion. Rinse thoroughly, then dry. Do not allow the cleaner to dry on surfaces or rinsing may be difficult.</p> <p>Apply cleaner with a non-abrasive cleaning pad. Allow 1 - 3 minutes dwell time. Rub with a circular motion. Rinse thoroughly, then dry. Do not allow the cleaner to dry on surfaces or rinsing may be difficult.</p>



Table 7-1. Cleaning of Specific Areas and Components - Continued

Area or Component	Type of Contaminant	Cleaning Agent	Mixing Directions and Nomenclature	Cleaning Procedures
				
		MIL-PRF-680 AND A-A-59601, SOLVENT, DEGREASING, TYPE II AND III		45
				
		MIL-PRF-85570, CLEANING COMPOUND, AIRCRAFT		51
				
		MIL-PRF-87937, CLEANING COMPOUND, AIRCRAFT		52
				
<p>Do not allow MIL-PRF-87937 or MIL-PRF-85570, Type I cleaning solutions to contact canopy, window, or windshield/windscreen transparent plastic panels as they may cause crazing.</p>				
<b>INTERIOR AREAS</b>				
Floor and Deck	Dirt, debris	MIL-PRF-87937, Type IV or MIL-PRF-85570, Type II (Preferred)	1 part cleaner in 9 parts water	Remove loose dirt with vacuum cleaner. Wipe with cleaning compound and rinse with fresh water. Use of MIL-PRF-87937, Type I, is subject to restrictions noted above in Exterior Painted Surfaces.
		or MIL-PRF-87937 or MIL-PRF-85570, Type I (Alternate)	1 part cleaner in 16 parts water	
Radome and Equipment Compartment (interior)	Dust, dirt, oil, and debris	MIL-PRF-87937, Type IV or MIL-PRF-85570, Type II	1 part cleaner in 16 parts water	Remove loose dirt with a vacuum cleaner. Wipe fiberglass and other surfaces with a cloth wet with cleaning solution and rinse with cloth wet with fresh water. Dry with a clean CCC-C-440, Type I or II cloth.
		and CCC-C-440, Type I or II, Class 1 or A-A-59323, Type II, or AMS 3819, Class 1, Grade A or B	Cotton Cheese-cloth (Unbleached) Cleaning Cloth, Low Lint White Cleaning Cloth	
<b>ACRYLIC PLASTIC PARTS</b>	Light soil and smudges	MIL-PRF-87937, Type IV or MIL-PRF-85570, Type II	1 part cleaner in 16 parts water	Wipe with cloth wet with cleaning solution and follow with a cloth wet with fresh water. Dry with a clean cloth.
		A-A-50129	Cloth, Flannel	

TO 1-1-700

Table 7-1. Cleaning of Specific Areas and Components - Continued



Area or Component	Type of Contaminant	Cleaning Agent	Mixing Directions and Nomenclature	Cleaning Procedures
				
MIL-PRF-680 AND A-A-59601, SOLVENT, DEGREASING, TYPE II AND III				45
				
MIL-PRF-85570, CLEANING COMPOUND, AIRCRAFT				51
				
MIL-PRF-87937, CLEANING COMPOUND, AIRCRAFT				52
INTERIOR PLASTIC AND GLASS PANELS		A-A-50129	Cloth, Flannel	Vacuum and then dust with soft, clean, damp cloth. Keep cloth free of grit by rinsing frequently in water and wringing out.
ELASTOMERIC SEALS	Dust, dirt, oil, and grime	MIL-PRF-87937, Type IV or MIL-PRF-85570, Type II  CCC-C-440, Type I or II, Class 1  or  A-A-59323, Type II or AMS 3819, Class 1, Grade A or B	1 part cleaner in 9 parts water  Cotton Cheese-cloth (Unbleached)  Cleaning Cloth (Low Lint) White  Cleaning Cloth	Wipe with cloth wet with cleaning solution and rinse with a cloth wet with fresh water. Dry with a clean cloth.
FABRIC PARTS AND UPHOLSTRY	Light soil and oil spots	MIL-PRF-87937, Type IV or MIL-PRF-85570, Type II	1 part cleaner in 4 parts	Remove loose dirt with vacuum cleaner. Apply soap solution with sponge and scrub briskly. Rinse with clean, dampened rag or sponge using clean, fresh water. Allow area to dry. Raise nap by brushing.

Table 7-1. Cleaning of Specific Areas and Components - Continued



Area or Component	Type of Contaminant	Cleaning Agent	Mixing Directions and Nomenclature	Cleaning Procedures
				
MIL-PRF-680 AND A-A-59601, SOLVENT, DEGREASING, TYPE II AND III				45
				
MIL-PRF-85570, CLEANING COMPOUND, AIRCRAFT				51
				
MIL-PRF-87937, CLEANING COMPOUND, AIRCRAFT				52
<div style="border: 1px solid black; padding: 5px; display: inline-block; margin: 10px auto; width: 100px;"> <b>WARNING</b> </div> <p style="text-align: center; margin-top: 10px;">Open all circuit breakers associated with battery power (refer to applicable system specific maintenance manuals) prior to application of MIL-PRF-680, Degreasing Solvent or A-A-59601 Dry Cleaning and Degreasing Solvent, PD680.</p>				
<div style="border: 1px solid black; padding: 5px; display: inline-block; margin: 10px auto; width: 100px;"> <b>CAUTION</b> </div> <p style="text-align: center; margin-top: 10px;">Do not use excessive cleaning solvent on control cables. Solvent will remove internal lubricant.</p>				
CONTROL CABLES	Dust, dirt, oil, grease	A-A-59601 or MIL-PRF-680, Type II  MIL-C-81309, Type II and  MIL-PRF-16173, Grade 4	Degreasing Solvent  Water Displacing, CPC  CPC	Wipe with clean cloth dampened with solvent. Apply MIL-C-81309, Type II water displacing CPC to cables, and recoat cables with MIL-PRF-16173, Grade 4 CPC.

Table 7-1. Cleaning of Specific Areas and Components - Continued



Area or Component	Type of Contaminant	Cleaning Agent	Mixing Directions and Nomenclature	Cleaning Procedures
				
		MIL-PRF-680 AND A-A-59601, SOLVENT, DEGREASING, TYPE II AND III		45
				
		MIL-PRF-85570, CLEANING COMPOUND, AIRCRAFT		51
				
		MIL-PRF-87937, CLEANING COMPOUND, AIRCRAFT		52
<div style="border: 1px solid black; padding: 5px; display: inline-block; margin: 10px auto;"> <b>WARNING</b> </div> <p>Open all circuit breakers associated with battery power (refer to applicable system specific maintenance manuals) prior to application of MIL-PRF-680, Degreasing Solvent or A-A-59601 Dry Cleaning and Degreasing Solvent, PD680.</p> <div style="border: 1px solid black; padding: 5px; display: inline-block; margin: 10px auto;"> <b>CAUTION</b> </div> <p>Do not use MIL-PRF-16173, Grade 4 or MIL-C-85054 on micro-switches or exposed piston rod surfaces.</p>				
DOORS, LINKAGES, CYLINDERS	Dust, dirt, oil, grease	A-A-59601 or MIL- PRF-680, Type II  MIL-PRF-16173, Grade 4 or  MIL-C-85054	Degreasing Sol- vent  CPC  CPC	Brush surfaces as necessary with solvent. Cover rod ends and springs with MIL-PRF- 16173, Grade 4 CPC. Where lubrication is not required, MIL- C-85054 CPC may be applied.

Table 7-1. Cleaning of Specific Areas and Components - Continued



Area or Component	Type of Contaminant	Cleaning Agent	Mixing Directions and Nomenclature	Cleaning Procedures
				
MIL-PRF-680 AND A-A-59601, SOLVENT, DEGREASING, TYPE II AND III				45
				
MIL-PRF-85570, CLEANING COMPOUND, AIRCRAFT				51
				
MIL-PRF-87937, CLEANING COMPOUND, AIRCRAFT				52
<div style="border: 1px solid black; padding: 5px; width: fit-content; margin: 0 auto;"><b>WARNING</b></div> <p>Open all circuit breakers associated with battery power (refer to applicable system specific maintenance manuals) prior to application of TT-I-735 Isopropyl Alcohol.</p>				
<div style="border: 1px solid black; padding: 5px; width: fit-content; margin: 0 auto;"><b>CAUTION</b></div> <p>Do not use synthetic wiping clothes with flammable solvents such as TT-I-735 Isopropyl Alcohol.</p>				
ORGANIC MATERIALS; MILDEW, MOLD, FUNGUS, ETC.	Fungi, mold, mildew, etc.	TT-I-735  CCC-C-440, Type I or II, Class 1 or A-A-59323, Type II or AMS 3819, Class 1, Grade A or B  NAVCLEAN, Mildew Remover Kit NSN 6850-01-581-2150 (Single Kit) NSN 6850-01-581-2172 (Five Single Kits)	Isopropyl Alcohol  Cotton Cheese-cloth Cleaning Cloth  Low Lint Cleaning Cloth	<p>Wipe with clean cloth wet with isopropyl alcohol. To prevent recurring fungus growth, keep area dry and clean. For treatment of fungus in fuel systems, contact the appropriate aircraft SPD and/or missile or equipment SPM.</p> <p>Apply using a clean cheesecloth or soft bristle brush. Allow to remain on surface for 5-15 minutes. Thoroughly rinse treated surfaces with fresh water to ensure no residue remains. Re-apply mildew remover as necessary followed by thorough rinsing. Inspect treated surfaces for detergent residue. If any indication of residue remains, rinse treated surfaces again with fresh water and re-inspect. Repeat process as necessary to remove residue.</p>

Table 7-1. Cleaning of Specific Areas and Components - Continued





Area or Component	Type of Contaminant	Cleaning Agent	Mixing Directions and Nomenclature	Cleaning Procedures
		MIL-PRF-680 AND A-A-59601, SOLVENT, DEGREASING, TYPE II AND III	45	
		MIL-PRF-85570, CLEANING COMPOUND, AIRCRAFT	51	
		MIL-PRF-87937, CLEANING COMPOUND, AIRCRAFT	52	
 <p>Nickel-cadmium batteries must not be exposed to acid or acid vapors. Battery electrolytes are extremely corrosive. Spilled electrolyte shall be removed immediately. Refer to applicable system specific aircraft, missile, or equipment manuals for battery type. Fumes from overheated electrolyte will spread to adjacent areas, causing rapid corrosion on unprotected surfaces.</p>				
BATTERY COMPARTMENTS	Nickel-cadmium battery electrolyte deposits (potassium hydroxide solution)	A-A-59282 or ANSI/AWWA B 504  MIL-PRF-81309, Type II, Class 1 or 2, or MIL-L-87177, Type I or II, Grade B	Boric Acid  Monobasic sodium phosphate  Mix either material 6 oz in 1 gallon water  Water Displacing CPC	Remove spilled electrolyte immediately by flushing with fresh water. Spray the contaminated area with Bromothymol Blue solution (Refer to TO 1-1-691, Chapter 7). Neutralize the area by sponging or spraying generously with boric acid or sodium phosphate solution. Brush with a fiber bristle brush and flush with fresh water. Reapply the Bromothymol Blue solution to determine if all the electrolyte has been neutralized. Retreat area as required and rinse. Dry with clean wiping clothes. Keep the cell vents open, but do not allow any solutions to enter the cells. Preserve compartment with MIL-PRF-81309, Type II, Class 1 or 2 or MIL-L-87177, Type I or II, Grade B CPC. Do not paint or preserve batteries.





Table 7-1. Cleaning of Specific Areas and Components - Continued

Area or Component	Type of Contaminant	Cleaning Agent	Mixing Directions and Nomenclature	Cleaning Procedures
				<p>MIL-PRF-680 AND A-A-59601, SOLVENT, DEGREASING, TYPE II AND III 45</p> <p>MIL-PRF-85570, CLEANING COMPOUND, AIRCRAFT 51</p> <p>MIL-PRF-87937, CLEANING COMPOUND, AIRCRAFT 52</p>
BATTERY COMPARTMENTS - Continued	Lead-acid battery electrolyte deposits (sulfuric acid solution)	ASTM D 928  MIL-PRF-81309, Type II, Class 1 or 2, or MIL-L-87177, Type I or II, Grade B	Sodium Bicarbonate, 6 oz in 1 gallon water  Water Displacing CPC	Remove spilled electrolyte immediately by flushing with fresh water. Spray the contaminated area with Litmus solution (Refer to TO 1-1-691, Chapter 7). Neutralize the area by sponging or spraying with sodium bicarbonate solution. Apply generously until bubbling stops and the Litmus solution turns blue. Let it stay on the surface for 5 minutes, but do not allow to dry. Brush with a fiber bristle brush, then flush with fresh water. Reapply the Litmus solution to determine if all electrolyte has been neutralized. Retreat the area as required and rinse. Dry with clean wiping clothes. Keep the cell vents open but do not allow an solutions to enter the cells. Preserve compartment with MIL-PRF-81309, Type II, Class 1 or 2 or MIL-L-87177, Type I or II, Grade B CPC. Do not paint or preserve batteries.
BILGE AREAS	Hydraulic fluid, water, dirt, metallic debris	MIL-PRF-87937, Type IV or MIL-PRF-85570, Type II  or	1 part cleaner in 9 parts water	Vacuum clean liquids and debris. Wipe area with a sponge dampened in cleaning solution. Rinse by sponging with fresh water. Wipe dry with a clean cloth.

TO 1-1-700

Table 7-1. Cleaning of Specific Areas and Components - Continued

Area or Component	Type of Contaminant	Cleaning Agent	Mixing Directions and Nomenclature	Cleaning Procedures	
					
MIL-PRF-680 AND A-A-59601, SOLVENT, DEGREASING, TYPE II AND III				45	
					
MIL-PRF-85570, CLEANING COMPOUND, AIRCRAFT				51	
					
MIL-PRF-87937, CLEANING COMPOUND, AIRCRAFT				52	
BILGE AREAS - Continued	Algae contamination	MIL-PRF-87937 or MIL-PRF-85570, Type I	1 part cleaner in 16 parts water	Use of MIL-PRF-87937, Type I may be restricted as noted in Exterior Painted Surfaces.	
		or	A-A-59601 or MIL-PRF-680, Type III	Degreasing Solvent	Wipe with cloth dampened with solvent. Wipe dry with a clean cloth.
		MIL-PRF-87937, Type IV or MIL-PRF-85570, Type II	1 part cleaner in 4 parts water	Mix cleaner and water in a pump spray bottle. Spray mixture on contaminated area and allow it to dwell at least 2 minutes. Wipe off with a sponge and dry with a clean cloth.	
		or	MIL-PRF-87937 or MIL-PRF-85570, Type I	1 part cleaner in 9 parts water	Use of MIL-PRF-87937, Type I may be restricted as noted in Exterior Painted Surfaces.
		or	MIL-PRF-87937, Type III or MIL-PRF-85570, Type V	Undiluted concentrate	
OPTICAL GLASS	Dust, grease, oil	A-A-59199 and A-A-50129	Optical Cleaner Cloth, Flannel	Spray cleaner onto flannel and carefully wipe the lens or other optical surface. Wipe dry with clean flannel A-A-50129, Flannel cloth.	

### 7.3.1.2 Cleaning Equipment.



High pressure wash equipment which develops more than 175 PSI nozzle pressure shall not be used to apply cleaning compounds unless specifically authorized by the equipment SPM.

#### NOTE

Use only cleaning materials and equipment authorized and described in this manual. Experimentation with unauthorized cleaners may damage equipment thus reducing reliability and increasing maintenance costs.

7.3.1.2.1 High Pressure/Hot Wash Equipment. If approved by the equipment SPM, high pressure/hot water wash equipment can be used for general purpose cleaning of vans/shelters, support equipment, and vehicles. These machines can deliver four gallons per minute of water and/or cleaning solution at a temperature of 210 °F (99 °C) and a pressure of 3000 PSI at the attach points on the machine for each output hose. These machines shall be operated per these instructions and the directions in the specific equipment operating manual.

- a. Fill the cleaner reservoir with only approved cleaning compounds.
- b. Set the water to cleaning compound mixture ratio to 50 parts water and 1 part cleaner.
- c. Use only 40° flat fan spray nozzles.
- d. Ensure that the nozzle stand off distance to the surface is always at least 12 inches and never less.

#### NOTE

- Pressure and temperature at the nozzles will be less than at the hose attach points on the machine due to losses in the hoses.
- This equipment may remove any loose sealant and/or paint.

7.3.1.2.2 Portable, 15 gallon, Foam Generating, Cleaning Unit. This cleaning unit is compact, portable, light, and ideal for cleaning hard to reach areas. It consists of a 54 inch applicator wand, 50 feet of hose, and a 15 gallon tank mounted on a frame with rubber tire wheels. The control system allows

the operator to adjust the foam wetness to fit any job. The cleaning unit provides foam capable of clinging to vertical surfaces to soften and dislodge soils. These machines shall be operated per these instructions and the directions in the specific equipment operating manual:

#### WARNING

Do not service the portable 15 gallon foam generation cleaning unit without releasing the tank pressure.



When the cleaning task is completed, drain and flush the tank with fresh water to prevent forming an extremely concentrated solution by pouring additional cleaner into the solution remaining in the tank which could damage the equipment being cleaned.

- a. Release the tank pressure prior to servicing, and remove the tank fill cap. Fill the tank with an authorized, pre-diluted cleaning solution, while leaving an adequate air space at the top of the tank. Replace the tank fill cap.
- b. Connect the air supply hose to the air inlet valve on the air regulator.

#### NOTE

Refer to Table 7-1 for the proper cleaner to water mix ratio.

- c. Open the cleaning compound metering valve and the air inlet valve to the full position and set the air regulator to a pressure within the range of 30 to 70 PSI.
- d. Open the foam discharge valve while directing the nozzle at the surface to be cleaned.
- e. If the foam is too wet, close the cleaning compound metering valve slightly. If the foam is too dry, open the cleaning compound metering valve slightly and/or lower the air pressure slightly by adjusting the air regulator. Dry foams have a longer dwell time and prolong the cleaning operation, but wet foams clean better.
- f. Apply the foam to the surface and allow it to dwell for a minimum of one minute, but not long enough to dry on the surface, and then scrub with a cleaning kit, brush, or cloth and rinse. See Table 7-1 for additional instructions.

**TO 1-1-700**

7.3.1.2.3 Portable, 45 gallon, Foam Generating Cleaning Unit. This cleaning unit is a simplified, portable, pressure operated foam-dispensing system. It uses available air supply for its power source without using pumps. Air is metered directly into the pressurized solution chamber which forces cleaning solution into the hose to create foam. These machines shall be operated per these instructions and the directions in the specific equipment operating manual:

**WARNING**

Do not service the 45 gallon foam generating cleaning unit without releasing the tank pressure.

**CAUTION**

- When the cleaning operation is completed, drain the tank and flush with fresh water to prevent forming an extremely concentrated solution by pouring additional cleaner into the solution remaining in the tank which could damage the equipment being cleaned.
  - Release the tank pressure prior to servicing. Close the cleaning compound metering valve and the air valve, and open the air dump valve to bleed off retained air pressure.
- a. Open the tank by removing the cover retaining bolts and lifting off the cover. Fill the tank with an authorized, pre-diluted cleaning solution, while leaving an adequate air space at the top of the tank. Replace the cover and bolt it firmly in place.

**NOTE**

Refer to Table 7-1 for the proper cleaner to use.

- b. Make sure the cleaning compound metering valve and the air valve are closed; attach an airline to the air inlet/dump valve on the side of the unit; and fill the void in the tank with air until the pressure is within the range of 30 to 70 PSI as indicated at the air regulator.
- c. Open the air valve, and then open the cleaning compound metering valve slowly while pointing the nozzle at the surface to be cleaned. Adjust the cleaner compound metering valve until the desired foam consistency is reached.

- d. If the foam is too wet, close the cleaning compound metering valve slightly and/or open the air valve slightly. If the foam is too dry, open the cleaning compound metering valve slightly and/or close the air valve slightly.
- e. Apply the foam to the surface and allow it to dwell for a minimum of one minute, but not long enough to dry on the surface, and then scrub with a cleaning kit, brush, or cloth and rinse. See Table 7-1 for additional instructions.

**7.4 LUBRICATION.****CAUTION**

- Not all lubricating materials are compatible with each other and/or metals used in Air Force C-E-M equipment. Some are known to promote galvanic corrosion or cause paint or acrylic plastics to deteriorate. Using the correct lubricating material is critical. Do not use greases or oils with solid film lubricants. Use only lubricants specified by appropriate system specific manuals and/or cards.
- Do not lubricate Teflon bearings or bushings. Clean Teflon bearings and bushings with A-A-59601, Type II or III or MIL-PRF-680, Type II or III degreasing solvent.
- Lubricants containing graphite, both alone or in mixture with any other lubricants, shall not be used, since graphite is cathodic to most metals and will cause galvanic corrosion in the presence of electrolytes.

Lubrication performs a dual purpose: to prevent wear between moving parts; and also to fill air spaces, displace water, and provide a barrier against corrosive elements. The lubrication requirements contained in system specific maintenance manuals and/or cards are usually adequate to prevent corrosion of most lubricated surfaces under normal operating conditions. In the event that the specified lubricant is not available, request substitutions from the equipment SPM.

**NOTE**

Comply with re-lubrication time frame requirements outlined in the system specific maintenance manual.

7.4.1 Conventional Lubricants. Table 7-2 contains the title, specification, intended use, and temperature range of the most frequently used conventional lubricating materials.



- Do not use solid film lubricants in areas subject to rotational speeds above 1000 rpm under heavy loads or on roller bearing elements because they will not provide adequate lubrication in these situations.
- Do not use solid film lubricants in conjunction with oils or greases as they are not compatible.

**7.4.2 Solid Film Lubricants.** Solid film lubricants are used where conventional lubricants are difficult to apply or retain or where other lubricants may be contaminated with dust, wear

products, or moisture and to reduce fretting corrosion on close tolerance fittings that see primarily static loads with only very small relative movement caused by vibration. Typical applications of solid film lubricants are sliding motion components such as hinges, turnbuckles, and cargo latches.

**7.4.2.1** As with paints, surface preparation prior to application is extremely important to the service wear life of solid film lubricants. In reality, solid film lubricants are nothing more than paints with solid (powder) type lubricants used as the pigment. They are usually applied over surfaces pre-coated with other films, such as anodize (aluminum and magnesium base material), phosphate (steel base material), and sometimes over organic coatings such as epoxy primers.

**Table 7-2. Common Military Greases and Their Uses**

Specification and Nomenclature	Intended Use	Recommended Temperature Range
AMS-G-4343 Grease, Pneumatic System (NATO Code G-392)	Lubrication between rubber and metal parts of pneumatic systems; pressurized cabin bulkhead grommets and other mechanisms requiring rubber to metal lubrication.	-65 to 200 °F (-54 to 93 °C)
AMS-G-6032 Grease, Plug, Valve, Gasoline and Oil Resistant (NATO Code G-363)	Tapered plug valves; gasket lubricant or seal; general plug valve and fitting use where gasoline, oil, alcohol, or water resistance is required.	-32 to 200 °F (0 to 93 °C)
MIL-G-21164 Grease, Molybdenum Disulfide, for Low and High Temperatures (NATO Code G-353)	Heavily loaded steel sliding surfaces, accessory splines, or anti-friction bearings carrying high loads and operating through wide temperature ranges where molybdenum disulfide will prevent or delay seizure in the event of inadequate lubrication. This grease is not intended for use in wheel bearings.	-100 to 250 °F (-73 to 121 °C)
MIL-PRF-23827 Grease, Aircraft and Instrument, Gear and Actuator Screw (NATO Code G-354)	Lubrication of ball, roller, and needle bearings, gears, and sliding and rolling surfaces of equipment such as instruments, cameras, electronic gear and aircraft control systems that are subject to extreme marine and low temperature conditions; rolling and sliding surfaces of equipment with low motivating power (low torque equipment); general use on aircraft gears, actuator screws, and other equipment with high load carrying capacity. Its extremely low volatility makes it useful on aircraft optical equipment since it will not produce oil fogging.	-100 to 250 °F (-73 to 121 °C)
MIL-G-25013 Grease, Aircraft, Ball and Roller Bearing (NATO Code G-372)	Lubrication of ball and roller anti-friction bearings that operate at extreme high or low temperatures, especially in applications where soap-type petroleum or synthetic oil greases and oils cannot be used. Can be used on aircraft actuators, gearboxes, and similar equipment.	-100 to 450 °F (-73 to 232 °C)

Table 7-2. Common Military Greases and Their Uses - Continued

Specification and Nomenclature	Intended Use	Recommended Temperature Range
MIL-G-25537 Grease, Aircraft, Helicopter, Oscillating Bearing (NATO Code G-366)	Lubrication of aircraft bearings having oscillating motion of small amplitude.	-65 to 160 °F (-54 to 71 °C)
MIL-PRF-27617 Grease, Aircraft and Instrument, Fuel and Oxidizer Resistant	Lubrication of taper plug valves, gaskets, and bearings in aircraft and ground support equipment fuel systems; lubrication of valves, threads, and bearings of liquid oxygen (LOX) systems of aircraft, aerospace vehicles, and support equipment. Do not use on aluminum or magnesium dynamic bearings due to possible ignition hazard.	
Type I (NATO Code G-397)		-65 to +300 °F (-54 to +149 °C)
Type II (NATO Code G-398)		-40 to +400 °F (-40 to +204 °C)
Type III (NATO Code G-399)		-30 to +400 °F (-34 to +204 °C)
Type IV (NATO Code G-1350)		-100 to +400 °F (-73 to +204 °C)
Type V		-100 to +450 °F (-73 to +232 °C)
MIL-PRF-81322 Grease, Aircraft, General Purpose, Wide Temperature Range (NATO Code G-395)	NLGI Grade 1: arresting gear sheave spacers and other equipment that operates under high contact loads and high sliding speeds. NLGI Grade 2: aircraft wheel bearings and internal brake wheel assemblies, antifriction bearings, gearboxes, and plain bearings. Both will withstand high speed operations and operations on equipment subject to extreme marine environments.	-65 to 350 °F (-54 to 177 °C)



MIL-PRF-46010, LUBRICANT, SOLID FILM, HEAT CURED

42

7.4.2.2 SAE AS5272 (MIL-PRF-46010), Lubricant, Solid Film, Heat Cured, Corrosion Inhibiting is a cured, corrosion-inhibiting solid film lubricant that provides extended wear life. It can be used on aluminum, copper, steel, stainless steel, and titanium in areas of infrequent operation and in areas requiring long term protection under static conditions to prevent galling, corrosion, and metal seizure. Because SAE AS5272 (MIL-PRF-46010), Type II must be cured at 400 °F (205 °C) for 1 hour and Type I must be cured at 300 °F (149 °C) for 2 hours they are not suitable for all applications as metallurgical damage may occur at these temperatures.



MIL-PRF-46147, LUBRICANT, SOLID FILM, AIR CURED

43



MIL-L-23398, LUBRICANT, SOLID FILM

30

7.4.2.3 MIL-PRF-46147 and/or MIL-L-23398, Lubricant, Solid Film, Air Cured, Corrosion Inhibiting are air-cured corrosion-inhibiting solid film lubricants that can be used on aluminum, steel, and titanium in areas of infrequent operation and areas requiring long term protection under static conditions to prevent galling, corrosion, and metal seizure. They provide moderate wear life and corrosion protection in these areas when it is not feasible to use a solid film lubricant that requires curing at elevated temperatures, and can be used to



repair damaged SAE AS5272 (MIL-PRF-46010) heat cured solid film lubricants. MIL-L-23398, Type I (bulk) and Type II (aerosol) both require a 6-hour cure at a temperature of 77 °F  $\pm$ 3 °F (25 °C  $\pm$ 2 °C). MIL-PRF-46147, Form 1 (bulk) and Form 2 (aerosol); Type I (standard solvents) requires an 18-hour cure and Type II (low VOC content), both forms, requires a 24-hour cure at these same temperatures. Curing both MIL-L-23398 and MIL-PRF-46147 solid film lubricants may be accelerated by allowing air drying at room temperature for 30 minutes to flash off solvents and then heating to 124 °F  $\pm$ 5 °F (52 °C  $\pm$ 3 °C) for 1 to 1-1/2 hours.



MIL-PRF-63460, LUBRICANT, CLEANER AND PRESERVATIVE

44



MIL-PRF-81309, LUBRICANT, CORROSION PREVENTIVE COMPOUND

46



MIL-PRF-32033, LUBRICATING OIL, GENERAL PURPOSE, PRESERVATIVE (WATER-DISPLACING, LOW TEMPERATURE)

41



- When lubricating hinges and pinned joints, apply a generous quantity of either MIL-PRF-63460 (preferably); MIL-PRF-81309, Type II; or MIL-PRF-32033 water displacing, corrosion preventative compound (CPC) before applying any additional specified lubricant.
- Actuate hinges several times to make sure that the CPCs and lubricants penetrate all crevices thoroughly. Wipe off excess from exterior surfaces.

#### 7.4.3 Application of Conventional Lubricants.

7.4.3.1 Apply lubricants as sparingly as possible to prevent accumulation of dust, dirt, and other foreign matter, but always apply enough to provide adequate lubrication. Wipe away any excess lubricant. Using the proper method of application as specified in the appropriate system specific maintenance

manual is important. Apply lubricants by one of the following methods: grease guns, lever or pressure type; oil, squirt, and aerosol spray cans; hand or brush.



MIL-PRF-680 AND A-A-59601, SOLVENT, DEGREASING, TYPE II AND III

45

7.4.3.1.1 When applying grease type lubricants in pressure type grease fittings (Zerk Fittings) with a grease gun, clean grease fitting with A-A-59601, Type II or III or MIL-PRF-680, Type II or III degreasing solvent and clean cloth before applying lubricant. Make sure the lubricant has emerged around the bushing. If no grease appears, check the fitting and grease gun for proper operation. Be certain the grease gun is properly attached to the fitting prior to applying pressure.

7.4.3.1.2 When applying grease to a flush type (high pressure) fitting, make sure that the grease gun is fitted with a flush type adapter and held perpendicular to the surface of the fitting before applying pressure. If the fitting does not accept lubrication, replace the fitting and lubricate. Wipe excess grease from the fitting and surrounding surfaces with a clean, dry cloth.

#### 7.5 PRESERVATION.

Corrosion preventative compounds (CPC) or preservatives are used to protect metal equipment parts and components by preventing corrosive materials from contacting and corroding bare metal surfaces. Many of these compounds are also able to displace water, including sea water, and other contaminants from these surfaces, and some provide lubrication, as well as corrosion protection.

7.5.1 CPC Formulation. Generally, CPCs are mixtures of special additives in petroleum derivative bases (special oils or greases). The thicker CPCs provide the best corrosion protection, are longer lasting, and are more difficult to remove. The thinner materials provide some lubrication and do not crack, chip, or peel; but they must be removed and replaced regularly to provide continuing protection.

7.5.2 Operational Preservation. The day to day application of CPCs to prevent corrosion on operational equipment is known as operational preservation. Areas which are corrosion prone or where paint has been damaged should be routinely protected by CPCs until more permanent treatment, such as paint touchup or sealant, can be applied.

7.5.3 Non-Operational Preservation. Preservation of C-E-M equipment or components during periods of prolonged

**TO 1-1-700**

inactivity, storage, or shipment is known as non-operational preservation.

**7.5.4 Types of CPCs.** CPCs can be separated into two major categories: water displacing and non-water displacing compounds.

**7.5.4.1 Water Displacing Compounds.** Water displacing CPCs can be used to remove water, including sea water, or other electrolytes from metal surfaces. MIL-PRF-81309, MIL-PRF-63460, MIL-PRF-16173, Grade 3, and MIL-PRF-32033 are water displacing CPCs that are able to penetrate into cracks, crevices, voids at faying surface edges, around fastener heads, and into hinges. They usually provide very thin coatings, one mil (0.001 inch) or less in thickness, they are clear or translucent and remain soft and oily after application, so they cannot provide long term protection outdoors or in areas which are frequently handled.

**7.5.4.1.1 Water Displacing, Hard Film.** Another type, MIL-DTL-85054, differs from the other water displacing compounds as it doesn't penetrate into joints very well but forms a

relatively hard, dry film on exterior surfaces; and therefore, it can be used for protection outdoors and in areas of frequent handling.

**7.5.4.2 Non-Water Displacing Compounds.** Non-water displacing CPCs may be used on dried surfaces or on wet surfaces which have been first treated with a water displacing CPC. MIL-PRF-16173, Grades 1, 2, and 4 are non-water displacing CPCs. They are heavier bodied waxy type greases which provide long term corrosion protection by forming a barrier film on metal surfaces. These CPCs provide thicker coatings and are light brown to very dark brown in color, with a waxy greasy appearance. They provide good corrosion protection and in areas where large amount of water collect on or run off of structures.

**7.5.5 Time Limitations of CPCs.** Because of their temporary nature, CPCs must be regularly removed and replaced to provide continuing corrosion protection. Table 7-3 provides the recommended time intervals for indoor and outdoor CPC use.

**Table 7-3. Time Limitations for CPCs**

CPC	Outdoor <sup>1</sup>	Indoor <sup>2</sup>	Indoor Covered <sup>3</sup>
Soft Thin Films			
MIL-PRF-81309, Type II	14 Days	30 Days	180 Days
MIL-PRF-81309, Type III	5 Days	14 Days	90 Days
MIL-L-87177, Grade B	5 Days	14 Days	90 Days
MIL-PRF-16173, Grade 3	14 Days	30 Days	180 Days
Lubrication and Protection			
MIL-PRF-32033	5 Days	30 Days	180 Days
MIL-PRF-63460	5 Days	30 Days	180 Days
Hard Thick Films			
MIL-DTL-85054	90 Days	210 Days	365 Days
MIL-PRF-16173 Grade 4	90 Days	210 Days	365 Days
MIL-PRF-16173 Grade 2	90 Days	210 Days	365 Days
MIL-PRF-16173 Grade 1	210 Days	365 Days	365 Days

<sup>1</sup> Outdoor: Without cover; exposed to elements in a mild climate; absence of rain and other washing forces; free from air and water borne pollutants.

<sup>2</sup> Indoor: Hangars, shop areas, storage or parts accumulation areas, warehouses.

<sup>3</sup> Indoor covered: Items are wrapped or sealed in a water-resistant material and stored indoors in a hangar, warehouse, or shop area. Soft thin film CPCs were designed for indoor use and ease of removal.

7.5.6 Description of CPCs. A list of CPCs and their intended uses is summarized in Table 7-4.

**WARNING**

MIL-DTL-85054, MIL-PRF-63460, and MIL-PRF-81309 have been revised to eliminate ODCs. Some reformulated products now contain flammable solvents and/or propellants. Pay close attention to all CAUTION/WARNING labels on the product containers as well as in their MSDSs.

7.5.6.1 MIL-PRF-81309; Corrosion Preventive Compound, Water Displacing, Ultra Thin Film and MIL-L-87177; Lubricants, Corrosion Preventive, Water Displacing, Synthetic. MIL-PRF-81309 and MIL-L-87177 materials are general purpose corrosion preventive compounds for use when a thin, water displacing CPC is needed. MIL-PRF-81309 and MIL-L-87177 are for indoor protection and short term protection where surfaces can be re-coated when required.

7.5.6.1.1 These materials are excellent water displacing compounds which provide an ultra thin soft film (0.5 mils/0.0005 inch or less). The MIL-PRF-81309 specification covers two types of materials and the MIL-L-87177 specification covers one grade of material that are useful for Air Force purposes to provide temporary protection from corrosion while still being easily removable with solvent.

7.5.6.1.2 They should not be used around liquid oxygen fittings. All of these CPCs may be applied by dipping, brushing, or spraying with a pump or aerosol sprayer.

7.5.6.2 MIL-PRF-81309, Type II and MIL-L-87177, Grade B. These CPCs form a soft, thin film for general use on moving or sliding parts where some lubrication is needed, such as on hinges. These materials can be easily washed away by rain or wash procedures, so frequent reapplication may be required. They are useful in the protection of areas which cannot be properly drained or contain recesses that are particularly difficult to reach due to their excellent water displacing abilities.

7.5.6.3 MIL-PRF-81309, Type III and MIL-L-87177, Grade B. These CPCs form an ultra thin, soft film that provides excellent water displacement and corrosion protection for the interior of electrical, avionics, and other electronic equipment and connectors. Although these CPC coatings are non-conductive, they will allow electrical contact because their very soft, thin film is easily moved aside by mechanical action or contact. These materials are the only CPCs allowed for the interior use on electrical and electronic equipment.

7.5.6.4 MIL-DTL-85054 Corrosion Preventive Compound, Clear. MIL-DTL-85054 is a water displacing CPC which forms a clear, hard/dry, semi-flexible film. It is intended for use as a protective coating on bare metal areas where the paint system has been damaged or failed until touchup and/or repainting are practical. Because of its paint-like characteristics, it provides no lubrication and blocks electrical conductivity.

**NOTE**

- MIL-DTL-85054 can be applied by dipping, brushing, or spraying with a paint spray gun or an aerosol can; but it is primarily applied by spraying from aerosol cans. Invert the aerosol can after each use and spray to clear the spray tip (nozzle) of entrapped material.
- If an aerosol can does not spray, invert and depress the spray tip several times to clear the delivery tube and spray tip (nozzle).
- If the can still does not spray, remove and clean the plastic spray tip (nozzle) and then reinstall the spray tip (nozzle) and spray again to clear the delivery tube.
- Dip application provides only a very thin coating and therefore much less corrosion protection.
- Remove MIL-DTL-85054 if it is damaged due to abrasion, there are cracks in the coating, or if there is evidence of corrosion under the coating.
- Since excessive MIL-DTL-85054 buildup is difficult to remove, especially after prolonged exposure to direct sunlight, remove previously applied coatings before reapplication. If the solvents recommended in Table 7-5 do not remove old films of MIL-DTL-85054, spraying on fresh MIL-DTL-85054 to soften the film and wiping or rubbing while wet is often effective.

7.5.6.5 MIL-PRF-16173 Corrosion Preventive Compound, Solvent Cutback, Cold Application. MIL-PRF-16173 covers five different grades of CPCs, four which can be applied by brushing or dipping. Grades 1, 2, and 4 do not displace water and must be applied to dried surfaces after joint areas have been treated with MIL-PRF-81309, Type II or III, MIL-L-87177, Grade B or MIL-PRF-16173, Grade 3 to penetrate into the joints.

**TO 1-1-700**

7.5.6.5.1 Grade 1 - A thick, hard, black CPC which can be removed with difficulty using mineral spirits or degreasing solvents. It offers the most corrosion protection of all the CPCs indoors and outdoors and may be used at temperatures down to 0 °F (-18 °C). If used at temperatures below 0 °F (-18 °C), the CPC film can crack and fall off leaving the surface unprotected.

7.5.6.5.2 Grade 2 - A thick, soft, grease-like, brown CPC that remains tacky and can be removed with mineral spirits or degreasing solvents. It protects under relatively severe conditions and given adequate maintenance touch-up as necessary, can be used for most maximum protection requirements. It may be used at temperatures down to -40 °F. It is not a good choice for parts that are handled frequently since it remains tacky.

7.5.6.5.3 Grade 3 - A thin, soft, oily film, water displacing CPC. This CPC doesn't penetrate into tight joints as well as MIL-PRF-81309, Type II or MIL-L-87177, Grade B, so one of them should be used as a substitute for this type of application.

**NOTE**

Remove the MIL-PRF-16173, Grade 3 film with A-A-59601, Type II or III or MIL-PRF-680, Type II or III degreasing solvent prior to inspecting an area when the coating is dark and prevents visual inspection of the underlying surface for cracks.

7.5.6.5.4 Grade 4 - A thick, soft, waxy type CPC that dries to a tack free, semi-transparent film through which identification can be read. It provides good protection under relatively severe conditions when touched-up as necessary. It is excellent for use on in service equipment over MIL-PRF-81309, Type II, MIL-L-87177, Grade B, or MIL-PRF-16173, Grade 3 water displacing CPC since it dries to a tack free film.



- If MIL-PRF-63460 is used in an area which will later be sealed or totally enclosed with no ventilation, allow at least 4 hours for the solvent to evaporate prior to sealing or closing off the area. Although MIL-PRF-63460 is a corrosion preventive compound, its solvent vapors may cause corrosion if not allowed to dissipate.
- Do not use MIL-PRF-63460 on rubber or other elastomeric parts. MIL-PRF-63460 contains solvents which attack rubber "O" rings and other elastomeric parts. Do not use as a direct substitute for MIL-PRF-32033 (VV-L-800).
- Do not use corrosion preventive compounds on the interior of fuel tanks or fuel cells, engines, or engine fuel systems as fouling of fuel systems may occur.
- Do not use corrosion preventive compounds on engine parts or accessories which exceed 800 °F (427 °C). Corrosive reactions may occur with CPCs at high temperatures.
- CPCs are not compatible with liquid oxygen and should not be used on oxygen equipment, lines, fittings, or storage bottles. Fire may result.

7.5.6.6 MIL-PRF-63460 Lubricant, Cleaner, and Preservative. MIL-PRF-63460 is a thin, water displacing, protective, penetrating lubricant used for cleaning, lubrication, and preservation of equipment hinges and fitting joints that experience only minor and infrequent relative motion. This material has good lubricating properties between -65 °F and +150 °F (-54 °C and +65 °C), and it is the best lubricant of all water displacing CPCs. It may be applied by brushing, dipping, or spraying by aerosol can or a pump sprayer.

**NOTE**

Use only CPCs authorized by and described in this manual and/or a system specific equipment manual.

Table 7-4. Corrosion Preventive Compounds

Specification and Nomenclature	Intended Use	Type of Coating
WATER-DISPLACING CPCs		
MIL-PRF-32033 Lubricating Oil, General Purpose, Preservative, (Water Displacing, Low Temperature); Military Symbol PL-S; NATO Code O-190	Lubrication and corrosion protection of hinges, other moving parts, small arms and automatic weapons, and wherever a low temperature, water displacing lubricant is required; requires frequent reapplications.	Soft, oily coating and lubricant
MIL-PRF-63460 Lubricant, Cleaner, and Preservative for Weapons and Weapons Systems; Military Symbol CLP; NATO Code S-758	Lubrication and short term preservation of hinges, and small and large caliber weapons in all climatic conditions within a temperature range of -65 to +150 °F (-54 to +66 °C); facilitates the effective removal of firing residues, gums, and other contaminants from weapons components while providing adequate lubrication and short term preservation. Of all water displacing CPCs, this material is the best lubricant. Excellent water displacing characteristics and penetration into tight joints.	Thin corrosion preventive lubricant film
MIL-PRF-16173 Corrosion Preventive Compound, Solvent Cut-back, Cold Application, Grade 3	Displacement of water; short term corrosion protection of metal surfaces during shipment, storage, and in service use; can be used on moving parts where minor lubrication is required, such as on hinges, bomb racks, and sliding parts.	Soft, oily, thin film (1.0 mil), light amber color
MIL-PRF-81309 Corrosion Preventive Compounds, Water Displacing, Ultra-thin Film		
Type II	Displacement of water; short term corrosion protection of metal surfaces during shipment, storage, and in service use; corrosion protection of moving parts where very minor lubrication is required, such as hinge areas, bomb racks, and sliding parts. Cannot be used on interior of electrical or electronic equipment and connectors.	Soft, oily, very thin film (0.5 mil) translucent, light amber color
Type III	Displacement of water; corrosion protection of electrical, avionics, and other electronic equipment, electrical connector plugs and contact pins. This material and MIL-L-87177, Grade B are the only CPCs that can be used on the interior of electrical or electronic equipment and connectors.	Soft, oily, ultra thin film (0.2 mil), translucent, light amber color.
MIL-L-87177 Lubricants, Corrosion Preventive, Water Displacing, Synthetic Grade B	Displacement of water, corrosion protection, and some lubrication on in service lightly loaded moving parts. Can be used on interior of electrical, avionics and other electronics equipment and connectors.	Soft, oily, thin film (0.5 mil), translucent, light amber color
MIL-DTL-85054 Corrosion Preventive Compound, Water Displacing, Clear	Corrosion protection and water displacement for non-moving parts, such as skin seams, installed fastener heads where paint has cracked, access panel edges, and areas with damaged paint. Cannot be used on interior areas of electrical or electronics equipment and connectors or in joint areas of moving parts as it dries to a hard film.	Dry, thin film (1.0 mil), transparent, colorless to slight blue tint

**Table 7-4. Corrosion Preventive Compounds - Continued**

Specification and Nomenclature	Intended Use	Type of Coating
NON-WATER DISPLACING CPCs		
MIL-PRF-16173 Corrosion Preventive Compound, Solvent Cut-back, Cold Application		
Grade 1	Protection of metal surfaces against corrosion when exposed with or without covering indoors or outdoors. Cannot be used if temperatures will fall below 0 °F (-18 °C) as the film will crack and can peel from the surface leaving it unprotected.	Hard, tack-free, thick film (4.0 mils), dark brown or black color
Grade 2	Protection of metal surfaces against corrosion during rework or storage; film remains tacky.	Soft, non-drying, thick (2.0 mils), light brown color
Grade 4	Protection of metal surfaces against corrosion during indoor storage when a transparent coating is required; coating of aircraft and equipment interior, metal wire control cables.	Soft, tack-free, thick (2.0 mils), light brown color

#### 7.6 PRESERVATION OF SPECIFIC AREAS.

Table 7-5 provides procedures for the preservation of specific areas and components where the use of a CPC on exposed metal surfaces is generally recommended for reducing corrosion. This list does not constitute authority to use CPCs on

specific equipment. The use of some or all types of CPCs in certain areas or on equipment may be detrimental. Therefore, consult the appropriate system specific equipment corrosion and/or maintenance manuals before applying a CPC in a new area to determine which compounds should be used in that area.





MIL-DTL-85054, COMPOUND, CORROSION PREVENTIVE

25



MIL-PRF-680 AND A-A-59601, SOLVENT, DEGREASING, TYPE II AND III

45



MIL-PRF-81309, LUBRICANT, CORROSION PREVENTIVE COMPOUND

46



MIL-PRF-63460, LUBRICANT, CLEANER AND PRESERVATIVE

44



MIL-L-87177, LUBRICANT, CORROSION PREVENTIVE COMPOUND, WATER DISPLACING

32



MIL-PRF-32033, LUBRICATING OIL, GENERAL PURPOSE, PRESERVATIVE (WATER-DISPLACING, LOW TEMPERATURE)

41



MIL-PRF-16173, COMPOUND, CORROSION PREVENTIVE

37

**WARNING**

Do not use synthetic wiping rags or cloths with the use of these materials as they will dissolve the synthetic cloth/rag.

**Table 7-5. Preservation of Specific Areas and Components**

Area or Component	CPC	Application Instructions	Removal Instructions
<b>NOTE</b> Prior to the application of preservatives (CPCs), ensure removal of old preservative CPC coatings.			
<p><b>EXTERIOR SURFACES NOT REQUIRING LUBRICATION</b></p> <p>Unpainted areas and areas with damaged paint which do not require lubrication (fastener heads; faying surface, access panel, door, and frame edges; attachment points; nonmoving attachment hardware; wheel well areas; ram air ducts; and flap/slat cavities)</p>	<p>MIL-DTL-85054</p> <p>or</p> <p>MIL-PRF-81309, Type II</p> <p>or</p> <p>MIL-L-87177 Grade B and</p> <p>MIL-PRF-16173, Grade 4</p>	<p>Wipe off dirt and excess moisture. Apply thin coating of MIL-DTL-85054. Allow to dry 1/2 hour. Apply a second coat.</p> <p>Wipe off dirt and excess moisture. Apply a coating of MIL-PRF-81309, Type II or MIL-L-87177, Grade B followed by a coating of MIL-PRF-16173, Grade 4.</p>	<p>Use a non-synthetic wiping cloth wet with A-A-59601, Type II or III, or MIL-PRF-680, Type II or III degreasing solvent. For stubborn MIL-DTL-85054, refer to TO 1-1-691, Chapter 3.</p>

Table 7-5. Preservation of Specific Areas and Components - Continued

Area or Component	CPC	Application Instructions	Removal Instructions
<p>EXTERIOR SURFACES NOT REQUIRING HIGH PERFORMANCE LUBRICANT OR HYDRAULIC FLUID</p> <p>Sliding or moving parts requiring only minor lubrication (bomb rack components, hinges, door locks)</p>	<p>MIL-PRF-63460 or</p> <p>MIL-PRF-81309, Type II or</p> <p>MIL-L-87177, Grade B and MIL-PRF-32033</p>	<p>Apply a continuous wet coat of MIL-PRF-63460.</p> <p>Apply a coating of MIL-PRF-81309, Type II or MIL-L-87177, Grade B followed by a coating of MIL-PRF-32033. If handled, reapply as necessary.</p>	<p>Use a non-synthetic wiping cloth wet with A-A-59601, Type II or III, or MIL-PRF-680, Type II or III degreasing solvent.</p>
<p>THREADED SURFACES</p> <p>Screws, various fasteners</p>	<p>MIL-PRF-63460</p>	<p>Dip screws or fasteners in CPC and install. When disassembly is frequent, use MIL-PRF-63460, preferably, or use MIL-PRF-81309, Type II or MIL-L-87177, Grade B as alternates. When disassembly is infrequent, use MIL-PRF-16173, Grade 4 for long term protection.</p>	<p>Immerse screws or fasteners in A-A-59601, Type II or III, or MIL-PRF-680, Type II or III degreasing solvent and blot or blow dry.</p>
<p>HYDRAULIC PISTON SURFACES</p>	<p>System hydraulic fluid</p>	<p>Wipe exposed surface with a cloth dampened with the hydraulic fluid used in the system. Always wipe away from seals. Take care not to scratch surfaces.</p>	<p>Do not remove. Reapply as necessary.</p>
<p>CONTROL CABLES (ALL) (INTERIOR and EXTERIOR)</p>	<p>MIL-PRF-81309, Type II or</p> <p>MIL-L-87177, Grade B or</p> <p>MIL-PRF-16173, Grade 3 and</p> <p>MIL-PRF-16173, Grade 4</p>	<p>Apply a continuous film of MIL-PRF-81309, Type II; MIL-L-87177, Grade B; or MIL-PRF-16173, Grade 3 water displacing CPC by aerosol can or by wiping with cloth wet with the CPC.</p> <p>Follow with a coating of MIL-PRF-16173, Grade 4 applied with a non-synthetic cloth or a nonmetallic bristle brush.</p>	<p>Use a non-synthetic wiping cloth wet with A-A-59601, Type II or III, or MIL-PRF-680, Type II or III degreasing solvent.</p>

**7.6.1 Preservation Application Methods.** CPCs can be applied by brushing, dipping, or spraying. The area of application, viscosity of the material and conditions under which they need to be applied are factors that influence the decision of which application method should be used. Low viscosity materials are best applied by spraying, where as high viscosity materials are more suited for brushing or dipping. Dipping can be used for all types of materials, but the thickness of the coating obtained with low viscosity materials may be too thin

to provide adequate corrosion protection. Prior to application of preservatives, remove old preservative coatings; and then apply a fresh coating using one of the following methods:

**7.6.1.1 Brushing.** Brushing may be accomplished using an ordinary paint brush. This method is most appropriate for applying thick materials on small areas or in area where it is necessary to prevent material from getting on surrounding areas or nearby equipment.

7.6.1.2 Dipping. Dipping may be accomplished using any suitable container for the CPC. It is most suitable for smaller disassembled parts. It cannot be used for assemblies which contain any part or area adversely affected by the CPC.



For spray application, do not thin or dilute bulk preservative (CPC) unless absolutely necessary. Do not use synthetic wiping cloths. Mask off adjacent areas to prevent overspray.

7.6.1.3 Spraying. Spraying may be accomplished using paint spraying equipment, various types of pump sprayers, or aerosol cans. This method is very effective for application to large areas where confined areas are not involved. The viscosity of the material will determine which type of spraying apparatus to use.

## 7.7 FINISHING.

7.7.1 Iron and Plain Low Carbon Steel. When complete refinishing is required due to extensive corrosion or loss of film adhesion, disassemble the equipment and/or structure as far as practical. Remove the defective paint system per procedures in Chapter 2 of TO 1-1-8.

7.7.1.1 If the surface, when reassembled in its normal operating position, will be exposed to direct view, the following procedure shall apply:

- a. Clean surface of dirt, oil, grease, welding flux, and all loose scale per procedures in Chapter 3 of TO 1-1-691.



MIL-C-10578, COMPOUND, CORROSION REMOVING AND METAL CONDITIONING 20

- b. For DEPOT LEVEL maintenance, surfaces of the disassembled steel parts shall be given a TT-C-490, Type I zinc phosphate treatment per procedures in TO 42C2-1-7 when treatment tanks are available. For FIELD LEVEL maintenance and when this treatment is impractical due to unavailability or part size, surfaces shall be treated with an appropriate Type of MIL-C-10578 metal conditioner per procedures in Chapter 5 of TO 1-1-691.

### NOTE

In lieu of the phosphate treatment, steel surfaces may be primed directly with MIL-PRF-26915 waterborne zinc rich primer applied per procedures in TO 1-1-8.



MIL-P-53022, PRIMER, EPOXY, CORROSION INHIBITING, LEAD AND CHROMATE FREE 34



MIL-P-53030, PRIMER, EPOXY, WATER REDUCIBLE, LEAD, CHROME FREE 35



MIL-DTL-64159, COATING, POLYURETHANE, CHEMICAL RESISTANT, WATERBORNE 24



MIL-PRF-23377, TYPE I & II, PRIMER, EPOXY CHEMICAL AND SOLVENT RESISTANT 38



MIL-PRF-85582, PRIMER, EPOXY, WATERBORNE 69



MIL-PRF-85285, COATING, POLYURETHANE, HIGH SOLIDS 50



MIL-PRF-26915, PRIMER, ZINC RICH, WATERBORNE 39

- c. Properly prepare the surface by solvent wiping per procedures in Chapter 3 of TO 1-1-8. Apply one coat of MIL-P-53022 (solvent type) or MIL-P-53030 (waterborne) epoxy primer to a dry film thickness (DFT) of 0.9 to 1.1 mils (0.0009 to 0.0011 inch) to surfaces that will be topcoated with MIL-DTL-64159 waterborne CARC polyurethane coating; or apply one coat of MIL-PRF-23377, Type I, Class A (solvent type) or MIL-PRF-85582, Type I, Class C2 (waterborne) epoxy primer to a DFT of 0.6 to 0.9 mils (0.0006 to 0.0009 inch) to surfaces that will be topcoated with MIL-PRF-85285 standard polyurethane coating. In either case,

## TO 1-1-700

MIL-PRF-26915 waterborne zinc rich primer may be applied to steel surfaces to a DFT of 2.0 to 3.0 mils (0.0020 to 0.0030 inch) for one coat or 4.0 to 6.0 mils (0.004 to 0.006 inch) in lieu of the epoxy primers. Application shall be per procedures in Chapters 4, 5, and 6 of TO 1-1-8.

- d. Apply two coats of either MIL-PRF-85285 standard polyurethane coating or MIL-DTL-64159 waterborne CARC polyurethane coating to a DFT of 1.8 to 3.2 mils (0.0018 to 0.0032 inch) over the primer per procedures in Chapters 4, 5, and 6 of TO 1-1-8. The color and gloss shall match the existing coating system as specified in equipment system specific technical data or as otherwise directed by the equipment SPM.

7.7.1.1.1 Where only partial refinishing (touch-up) is required for a few small scratches, nicks, or spots where corrosion was removed on painted surfaces, the following procedure shall be used:

- a. Scuff sand and feather out painted edges and all corroded or scratched surfaces to be refinished per maintenance painting and touch-up procedures in Chapter 5 of TO 1-1-8.
- b. Clean the entire surface to be touched-up of all dust, dirt, oil, and grease by solvent wiping per procedures in Chapter 3 of TO 1-1-8 prior to priming and top coating. Apply the same primers and topcoats noted in paragraph 7.7.1.1 using maintenance painting and touch-up procedures in Chapter 5 of TO 1-1-8.

7.7.1.2 If surface, when reassembled in its normal operating condition will not be exposed to direct view except while under repair, the following procedure shall be used:

- a. Clean surface of dirt, oil, grease, welding flux, and all loose scale per procedures in Chapter 3 of TO 1-1-691.



MIL-C-10578, COMPOUND, CORROSION REMOVING AND METAL CONDITIONING 20

- b. For DEPOT LEVEL maintenance, surfaces of the disassembled steel parts shall be given a TT-C-490, Type I zinc phosphate treatment per procedures in TO 42C2-1-7 when treatment tanks are available. For FIELD LEVEL maintenance and when this treatment is impractical due to unavailability or part size, surfaces shall be treated with an appropriate type of MIL-C-10578 metal conditioner per procedures in Chapter 5 of TO 1-1-691.

## NOTE

In lieu of the phosphate treatment, steel surfaces may be primed directly with MIL-PRF-26915 waterborne zinc rich primer applied per procedures in TO 1-1-8.



MIL-P-53022, PRIMER, EPOXY, CORROSION INHIBITING, LEAD AND CHROMATE FREE 34



MIL-P-53030, PRIMER, EPOXY, WATER REDUCIBLE, LEAD, CHROME FREE 35



MIL-PRF-23377, TYPE I & II, PRIMER, EPOXY CHEMICAL AND SOLVENT RESISTANT 38



MIL-PRF-85582, PRIMER, EPOXY, WATERBORNE 69



MIL-PRF-26915, PRIMER, ZINC RICH, WATERBORNE 39

- c. Properly prepare the surface by solvent wiping per procedures in Chapter 3 of TO 1-1-8. Apply one coat of MIL-P-53022 (solvent type) or MIL-P-53030 (waterborne) epoxy primer to a dry film thickness (DFT) of 0.9 to 1.1 mils (0.0009 to 0.0011 inch) to surfaces that require a CARC coating; or apply one coat of MIL-PRF-23377, Type I, Class A (solvent type) or MIL-PRF-85582, Type I, Class C2 (waterborne) epoxy primer to a DFT of 0.6 to 0.9 mils (0.0006 to 0.0009 inch) to surfaces that do not require a CARC coating. In either case, MIL-PRF-26915 waterborne zinc rich primer may be applied to steel surfaces to a DFT of 2.0 to 3.0 mils (0.0020 to 0.0030 inch) for one coat or 4.0 to 6.0 mils (0.004 to 0.006 inch) in lieu of the epoxy primers. Application shall be per procedures in Chapters 4, 5, and 6 of TO 1-1-8. No topcoat is required over the primer.

7.7.1.2.1 Where only partial refinishing (touch-up) is required for a few small scratches, nicks, or spots where corrosion was removed on painted surfaces, the following procedure shall be used:

- a. Scuff sand and feather out painted edges and all corroded or scratched surfaces to be refinished per maintenance painting and touch-up procedures in Chapter 5 of TO 1-1-8.
- b. Clean the entire surface to be touched-up of all dust, dirt, oil, and grease by solvent wiping per procedures in Chapter 3 of TO 1-1-8 prior to priming. Apply the same primers noted in paragraph 7.7.1.2 using maintenance painting and touch-up procedures in Chapter 5 of TO 1-1-8. No topcoat is required.

7.7.2 **Aluminum.** When complete refinishing is required due to extensive corrosion or loss of film adhesion, disassemble the equipment and/or structure as far as practical; and remove the defective paint system per procedures in Chapter 2 of TO 1-1-8.



MIL-DTL-81706 (ALODINE), COATING, CHEMICAL CONVERSION

23

#### NOTE

The presence of a white powdery oxide formation on cadmium plated fasteners will not in itself constitute reason for disassembly or overhaul unless these deposits interfere with proper operation of equipment. It will be sufficient to brush off accessible deposits of oxide with a stiff bristle brush, nonabrasive, and treat affected surface with MIL-DTL-81706/MIL-DTL-5541, Class 1A solution while treating the surrounding aluminum alloy structure.

7.7.2.1 If the surface, when reassembled in its normal operating condition will be exposed to direct view, the following procedure shall be used:

- a. For DEPOT LEVEL maintenance only new/replacement aluminum alloy parts shall be anodized per MIL-A-8625, Type II, Class I (dichromate or duplex sealed)

using procedures in TO 42C2-1-7. Structures that are too large to be anodized shall be treated according to the paragraph below.



MIL-DTL-81706 (ALODINE), COATING, CHEMICAL CONVERSION

23

- b. For both DEPOT and FIELD LEVEL maintenance, surfaces of repaired/refurbished aluminum alloy parts shall be treated to repair damaged areas in the anodize coating due to nicks, scratches, and corrosion removal with MIL-DTL-81706/MIL-DTL-5541, Class 1A chromate conversion coating per procedures in Section II of Chapter 5 in TO 1-1-691. For small areas, use MIL-DTL-81706, Class 1A, Form VI, Method D Touch-N-Prep™ (TNP) pens per procedures in Section II of Chapter 5 in TO 1-1-691.



MIL-PRF-23377, TYPE I & II, PRIMER, EPOXY CHEMICAL AND SOLVENT RESISTANT

38



MIL-PRF-85582, PRIMER, EPOXY, WATERBORNE

69



MIL-P-53030, PRIMER, EPOXY, WATER REDUCIBLE, LEAD, CHROME FREE

35

- c. Properly prepare the surface by solvent wiping per procedures in Chapter 3 of TO 1-1-8. Apply one coat of MIL-PRF-23377, Type I, Class C (solvent type), MIL-PRF-85582, Type I, Class C2 (waterborne) epoxy primer, or MIL-P-53030 (waterborne) epoxy primer to a DFT of 0.6 and 0.9 mils (0.0006 to 0.0009 inch). Application shall be per procedures in Chapters 4, 5, and 6 of TO 1-1-8.

## TO 1-1-700



MIL-PRF-85285, COATING, POLYURETHANE, HIGH SOLIDS 50



MIL-PRF-23377, TYPE I & II, PRIMER, EPOXY CHEMICAL AND SOLVENT RESISTANT 38



MIL-DTL-64159, COATING, POLYURETHANE, CHEMICAL RESISTANT, WATERBORNE 24



MIL-PRF-85582, PRIMER, EPOXY, WATERBORNE 69

- d. Apply two coats of either MIL-PRF-85285 standard polyurethane coating or MIL-DTL-64159 waterborne CARC polyurethane coating to a DFT of 1.8 to 3.2 mils (0.0018 to 0.0032 inch) over the primer per procedures in Chapters 4, 5, and 6 of TO 1-1-8. The color and gloss shall match the existing coating system as specified in equipment system specific technical data or as otherwise directed by the equipment SPM.

7.7.2.2 If surface, when reassembled in its normal operating condition will not be exposed to direct view except while under repair, the following procedure shall be used:

- a. For DEPOT LEVEL maintenance only, new/replacement aluminum alloy parts shall be anodized per MIL-A-8625, Type II, Class I (dichromate or duplex sealed) using procedures in TO 42C2-1-7.

- c. Surfaces finished per "step a." need no further finishing. Surfaces finished per "step b." will be primed with one coat of either MIL-PRF-23377, Type I, Class C (solvent type) or MIL-PRF-85582, Type I, Class C2 (waterborne) epoxy primer to a DFT of 0.6 and 0.9 mils (0.0006 to 0.0009 inch). Application shall be per procedures in Chapters 4, 5, and 6 of TO 1-1-8.

7.7.2.3 Where only partial refinishing (touch-up) is required for a few small scratches, nicks, or spots where corrosion was removed on painted surfaces, the following procedure shall be used:

- a. Scuff sand and feather out painted edges and all corroded or scratched surfaces to be refinished per maintenance painting and touch-up procedures in Chapter 5 of TO 1-1-8.
- b. Clean the entire surface to be touched-up of all dust, dirt, oil, and grease by solvent wiping per procedures in Chapter 3 of TO 1-1-8 prior to priming. Apply one coat of the same primers specified in paragraph 7.7.2.1 step c to all surfaces to be touched-up (both those exposed and unexposed to direct view in normal operating conditions) using maintenance painting and touch-up procedures in Chapter 5 of TO 1-1-8.
- c. If surfaces are exposed to direct view in normal operating conditions, apply one coat of the same topcoats specified in paragraph 7.7.2.1 step d over the primer using maintenance painting and touch-up procedures in Chapter 5 of TO 1-1-8.



MIL-DTL-81706 (ALODINE), COATING, CHEMICAL CONVERSION 23

- b. For both DEPOT and FIELD LEVEL maintenance, surfaces of repaired/refurbished aluminum alloy parts shall be treated to repair damaged areas in the anodize coating due to nicks, scratches, and corrosion removal with MIL-DTL-81706/MIL-DTL-5541, Class 1A chromate conversion coating per procedures in Section II of Chapter 5 in TO 1-1-691. For small areas, use MIL-DTL-81706, Class 1A, Form VI, Method D Touch-N-Prep™ (TNP) pens per procedures in Section II of Chapter 5 in TO 1-1-691.

7.7.3 **Magnesium.** The entire part, exposed or unexposed, shall be replaced with a new magnesium part when complete refinishing is required due to extensive corrosion along with loss of paint film adhesion. For treatment after removal of mild to moderate corrosion and touch-up of the paint system the following procedure shall be used:





MIL-PRF-87937, CLEANING COMPOUND, AIRCRAFT 52



MIL-PRF-85570, CLEANING COMPOUND, AIRCRAFT 51

- a. Clean surfaces with a MIL-PRF-87937, Type IV or a MIL-PRF-85570, Type II alkaline, water based cleaner per procedures in Table 7-1 to remove protective chipping treatment, dirt, oil, grease, welding flux, and loose scale followed by solvent wiping per procedures in Chapter 3 of TO 1-1-8.
- b. The properly cleaned surface shall be treated with an SAE AMS-M-3171 (MIL-M-3171), Type VI brush on chromate treatment per procedures in Section II of Chapter 3 in TO 1-1-691.



MIL-PRF-23377, TYPE I & II, PRIMER, EPOXY CHEMICAL AND SOLVENT RESISTANT 38

- c. Apply two coats of MIL-PRF-23377, Type I, Class C epoxy primer to all properly prepared and treated surfaces, exposed and unexposed to a total DFT of 1.2 and 1.8 mils (0.0012 to 0.0018 inch). Application shall be per procedures in Chapters 4, 5, and 6 of TO 1-1-8.



MIL-PRF-85285, COATING, POLYURETHANE, HIGH SOLIDS 50

- d. Apply two coats of MIL-PRF-85285 polyurethane topcoat over the primed surfaces to a total topcoat DFT of 1.8 to 3.2 mils (0.0018 to 0.0032 inch) over the primer per procedures in Chapters 4, 5, and 6 of TO 1-1-8. The color and gloss shall match the existing coating system as specified in equipment system specific technical data or as otherwise directed by the equipment SPM.

**7.7.4 Zinc and Cadmium Plated Surfaces.** When complete refinishing is required due to extensive corrosion or loss of film adhesion, disassemble the equipment and/or structure as far as practical; and remove the defective paint system per procedures in Chapter 2 of TO 1-1-8.



MIL-DTL-81706 (ALODINE), COATING, CHEMICAL CONVERSION 23

### WARNING

Cadmium and zinc platings are extremely toxic to eyes, skin and respiratory tract. Eye, skin and respiratory protection is required. Good general ventilation is normally adequate. Cadmium is also toxic if ingested. Wash hands thoroughly after handling or working with cadmium plating before eating, drinking, or smoking.

### NOTE

The presence of a white powdery oxide formation on cadmium plated surfaces, in particular fasteners, will not in itself constitute reason for disassembly or overhaul unless these deposits interfere with proper operation of equipment. It will be sufficient to brush off accessible deposits of oxide with a stiff bristle brush, nonabrasive, and treat affected surface with MIL-DTL-81706/MIL-DTL-5541, Class 1A solution while treating the surrounding aluminum alloy structure.

**7.7.4.1** For DEPOT LEVEL maintenance only, strip old plating from equipment or part to the base metal per procedures in TO 42C2-1-7. For FIELD LEVEL maintenance and when it impractical to strip the plating due to size, shape, or connection to other parts, lightly sand areas where corrosion is noted to remove corrosion products of the plating as well as the base metal per procedures in Chapter 5 of TO 1-1-691.

**7.7.4.2** If the surface is exposed to direct view in its normal operating condition, the following procedures shall be used:

- a. For DEPOT LEVEL maintenance only, replate surfaces with zinc per ASTM B-633 (QQ-Z-325) or cadmium per SAE AMS-QQ-P-416 (QQ-P-416) using procedures in TO 42C2-1-7. Both zinc and cadmium plating shall have at least a Class 2 coating with a minimum thickness of 0.2 mils (0.0002 inch) and preferably a Class 1 coating with a minimum thickness of 0.5 mils (0.0005 inch).
- b. Zinc plated surfaces shall receive either a Type II supplementary chromate treatment or a Type III supplementary phosphate treatment per ASTM B-633 (QQ-Z-325) using procedures in TO 42C2-1-7. Bleached or clear chromate treatment is not permissible.

## TO 1-1-700

- c. Cadmium plated surfaces shall receive either a Type II supplementary chromate treatment or a Type III supplementary phosphate treatment per SAE-AMS-QQ-P-416 (QQ-P-416) using procedures in TO 42C2-1-7. Bleached or clear chromate treatment of is not permissible.

**NOTE**

For DEPOT LEVEL maintenance, touch-up of small areas of zinc and/or cadmium plating may be accomplished by brush plating per MIL-STD-8651 using procedures in TO 42C2-1-7 in lieu of complete stripping and replating.



MIL-PRF-23377, TYPE I & II, PRIMER, EPOXY CHEMICAL AND SOLVENT RESISTANT 38



MIL-PRF-85582, PRIMER, EPOXY, WATERBORNE 69



MIL-P-53022, PRIMER, EPOXY, CORROSION INHIBITING, LEAD AND CHROMATE FREE 34



MIL-P-53030, PRIMER, EPOXY, WATER REDUCIBLE, LEAD, CHROME FREE 35

- d. Prime the plated surfaces with one coat of MIL-PRF-23377, Type I, Class C or MIL-PRF-85582, Type I, Class C2 epoxy primers to a DFT of 0.6 to 0.9 mils (0.0006 to 0.0009 inch) or MIL-P-53022 or MIL-P-53030 epoxy primers to a DFT of 0.9 to 1.1 mils (0.0009 to 0.0011 inch); as applicable from the equipment system specific technical data. Application shall be per procedures in Chapters 4, 5, and 6 of TO 1-1-8.



MIL-PRF-85285, COATING POLYURETHANE, HIGH SOLIDS 50



MIL-DTL-64159, COATING, POLYURETHANE, CHEMICAL RESISTANT, WATERBORNE 24

- e. Apply two coats of either MIL-PRF-85285 standard polyurethane coating or MIL-DTL-64159 waterborne CARC polyurethane coating to a DFT of 1.8 to 3.2 mils (0.0018 to 0.0032 inch) over the primer per procedures in Chapters 4, 5, and 6 of TO 1-1-8. The color and gloss shall match the existing coating system as specified in equipment system specific technical data or as otherwise directed by the equipment SPM.

7.7.4.3 If surface is not exposed to view in its normal operating condition, except while under repair, use the same procedures specified in paragraph 7.7.4.2 step a, step b., and step c., the NOTE under step c. and step d. Application of a topcoat per paragraph 7.7.4.2 step e is not required.

7.7.4.4 Where only partial refinishing (touch-up) is required for a few small scratches, nicks, or spots where corrosion was removed on painted surfaces, the following procedure shall be used:

- Scuff sand and feather out painted edges and all corroded or scratched surfaces to be refinished per maintenance painting and touch-up procedures in Chapter 5 of TO 1-1-8.
- Clean the entire surface to be touched-up of all dust, dirt, oil, and grease by solvent wiping per procedures in Chapter 3 of TO 1-1-8 prior to priming. Apply one coat of the same primers specified in paragraph 7.7.4.2 step d to all surfaces to be touched-up (both those exposed and unexposed to direct view in normal operating conditions) using maintenance painting and touch-up procedures in Chapter 5 of TO 1-1-8.
- If surfaces are exposed to direct view in normal operating conditions, apply one coat of the same topcoats specified in paragraph 7.7.4.2 step e over the primer using maintenance painting and touch-up procedures in Chapter 5 of TO 1-1-8.



MIL-DTL-81706 (ALODINE), COATING, CHEMICAL CONVERSION

23

### NOTE

The initial chromate surface treatment is required on these surfaces and may be applied by using MIL-DTL-81706, Class 1A, Form VI, Method D Touch-N-Prep™ (TNP) pens per procedures in Section II of Chapter 5 in TO 1-1-691.

**7.7.5 Tin on Ferrous Base Metal.** When complete refinishing is required due to extensive corrosion or loss of film adhesion, disassemble the equipment and/or structure as far as practical and remove the defective paint system per procedures in Chapter 2 of TO 1-1-8.

**7.7.5.1** If surface, when reassembled in its normal operating condition will be exposed to direct view, the following procedures will be used:

- a. For DEPOT LEVEL maintenance only, strip old plating from equipment or part to the base metal per procedures in TO 42C2-1-7. For FIELD LEVEL maintenance and when it is impractical to strip the plating due to size, shape, or connection to other parts, lightly sand areas where corrosion is noted to remove corrosion products of the plating as well as the base metal per procedures in Chapter 5 of TO 1-1-691.
- b. For DEPOT LEVEL maintenance, reapply tin plating by the hot dip method per ASTM B-339, Grade A to a minimum thickness of 0.5 mils (0.0005 inch) or by electroplating per ASTM B-545 to a minimum thickness of 0.3 mils (0.0003 inch) using procedures in TO 42C2-1-7, and treat the plated surface with the metal conditioner described in paragraph 7.8 of this manual.



MIL-PRF-23377, TYPE I & II, PRIMER, EPOXY CHEMICAL AND SOLVENT RESISTANT

38



MIL-PRF-85582, PRIMER, EPOXY, WATERBORNE

69



MIL-P-53022, PRIMER, EPOXY, CORROSION INHIBITING, LEAD AND CHROMATE FREE

34



MIL-P-53030, PRIMER, EPOXY, WATER REDUCIBLE, LEAD, CHROME FREE

35

- c. Prime the plated surfaces with one coat of MIL-PRF-23377, Type I, Class C or MIL-PRF-85582, Type I, Class C2 epoxy primers to a DFT of 0.6 to 0.9 mils (0.0006 to 0.0009 inch) or MIL-P-53022 or MIL-P-53030 epoxy primers to a DFT of 0.9 to 1.1 mils (0.0009 to 0.0011 inch), as applicable, from the equipment system specific technical data. Application shall be per procedures in Chapters 4, 5, and 6 of TO 1-1-8.



MIL-PRF-85285, COATING POLYURETHANE, HIGH SOLIDS

50



MIL-DTL-64159, COATING, POLYURETHANE, CHEMICAL RESISTANT, WATERBORNE

24

- d. Apply two coats of either MIL-PRF-85285 standard polyurethane coating or MIL-DTL-64159 waterborne CARC polyurethane coating to a DFT of 1.8 to 3.2 mils (0.0018 to 0.0032 inch) over the primer per procedures in Chapters 4, 5, and 6 of TO 1-1-8. The color and gloss shall match the existing coating system as specified in equipment system specific technical data or as otherwise directed by the equipment SPM.

**7.7.5.2** If the surface is not exposed to view in its normal operating condition, except while under repair, no further finish over plated surfaces will be required. However, plating thickness shall be a minimum of 0.5 mils (0.0005 inch) for hot dip and 0.3 mils (0.0003 inch) for electroplate.

**7.7.5.3** Where only partial refinishing (touch-up) is required for a few small scratches, nicks, or spots where corrosion was removed on painted surfaces, the following procedure shall be used:

## TO 1-1-700

- a. Scuff sand and feather out painted edges and all corroded or scratched surfaces to be refinished per maintenance painting and touch-up procedures in Chapter 5 of TO 1-1-8.
- b. Clean the entire surface to be touched-up of all dust, dirt, oil, and grease by solvent wiping per procedures in Chapter 3 of TO 1-1-8 prior to priming. Apply one coat of the same primers specified in paragraph 7.7.4.2 step d to all surfaces to be touched-up (both those exposed and unexposed to direct view in normal operating conditions) using maintenance painting and touch-up procedures in Chapter 5 of TO 1-1-8.
- c. If surfaces are exposed to direct view in normal operating conditions, apply one coat of the same topcoats specified in paragraph 7.7.4.2 step e over the primer using maintenance painting and touch-up procedures in Chapter 5 of TO 1-1-8.

**7.7.6 Tin on Copper and Copper Base Alloys.** When complete refinishing is required due to extensive corrosion or loss of film adhesion, disassemble the equipment and/or structure as far as practical. Remove the defective paint system per procedures in Chapter 2 of TO 1-1-8.

**7.7.6.1** If surface, when reassembled in its normal operating condition will be exposed to direct view, the following procedure shall be used:

- a. For DEPOT LEVEL maintenance only, strip old plating from equipment or part to the base metal per procedures in TO 42C2-1-7. For FIELD LEVEL maintenance and when it impractical to strip the plating due to size, shape, or connection to other parts, lightly sand areas where corrosion is noted to remove corrosion products of the plating as well as the base metal per procedures in Chapter 5 of TO 1-1-691.
- b. For DEPOT LEVEL maintenance, reapply tin plating by the hot dip method per ASTM B-339, Grade A to a minimum thickness of 0.7 mils (0.0007 inch) or by electroplating per ASTM B-545 to a minimum thickness of 0.5 mils (0.0005 inch) using procedures in TO 42C2-1-7, and treat the plated surface with the metal conditioner described in paragraph 7.8 of this manual.



MIL-PRF-23377, TYPE I & II, PRIMER, EPOXY CHEMICAL AND SOLVENT RESISTANT 38



MIL-PRF-85582, PRIMER, EPOXY, WATERBORNE 69



MIL-P-53022, PRIMER, EPOXY, CORROSION INHIBITING, LEAD AND CHROMATE FREE 34



MIL-P-53030, PRIMER, EPOXY, WATER REDUCIBLE, LEAD, CHROME FREE 35

- c. Prime the plated surfaces with one coat of MIL-PRF-23377, Type I, Class C or MIL-PRF-85582, Type I, Class C2 epoxy primers to a DFT of 0.6 to 0.9 mils (0.0006 to 0.0009 inch) or MIL-P-53022 or MIL-P-53030 epoxy primers to a DFT of 0.9 to 1.1 mils (0.0009 to 0.0011 inch); as applicable from the equipment system specific technical data. Application shall be per procedures in Chapters 4, 5, and 6 of TO 1-1-8.



MIL-PRF-85285, COATING POLYURETHANE, HIGH SOLIDS 50



MIL-DTL-64159, COATING, POLYURETHANE, CHEMICAL RESISTANT, WATERBORNE 24

- d. Apply two coats of either MIL-PRF-85285 standard polyurethane coating or MIL-DTL-64159 waterborne CARC polyurethane coating to a DFT of 1.8 to 3.2 mils (0.0018 to 0.0032 inch) over the primer per procedures in Chapters 4, 5, and 6 of TO 1-1-8. The color and gloss shall match the existing coating system as specified in equipment system specific technical data or as otherwise directed by the equipment SPM.

**7.7.6.2** If surface is not exposed to direct view in its normal operating condition, except while under repair, no further finish over plated surface shall be required. However, plating thickness shall be a minimum of 0.7 mils (0.0007 inch) for hot dip and 0.5 mils (0.0005 inch) for electroplating.

7.7.6.3 Where only partial refinishing (touch-up) is required for a few small scratches, nicks, or spots where corrosion was removed on painted surfaces, the following procedure shall be used:

- a. Scuff sand and feather out painted edges and all corroded or scratched surfaces to be refinished per maintenance painting and touch-up procedures in Chapter 5 of TO 1-1-8.
- b. Clean the entire surface to be touched-up of all dust, dirt, oil, and grease by solvent wiping per procedures in Chapter 3 of TO 1-1-8 prior to priming. Apply one coat of the same primers specified in paragraph 7.7.6.1 step c to all surfaces to be touched-up (both those exposed and unexposed to direct view in normal operating conditions) using maintenance painting and touch-up procedures in Chapter 5 of TO 1-1-8.
- c. If surfaces are exposed to direct view in normal operating conditions, apply one coat of the same topcoats specified in paragraph 7.7.6.1 step e over the primer using maintenance painting and touch-up procedures in Chapter 5 of TO 1-1-8. Surfaces not exposed to direct view require no topcoat.

**7.7.7 Nickel on Copper and Copper Base Alloys.** When complete refinishing is required due to extensive corrosion or loss of film adhesion, disassemble the equipment and/or structure as far as practical. Remove the defective paint system per procedures in Chapter 2 of TO 1-1-8.

7.7.7.1 If surface, when assembled in its normal operating condition, will be exposed to direct view, use the following procedure:

- a. For DEPOT LEVEL maintenance only, strip old plating from equipment or part to the base metal per procedures in TO 42C2-1-7. For FIELD LEVEL maintenance and when it is impractical to strip the plating due to size, shape, or connection to other parts, lightly sand areas where corrosion is noted to remove corrosion products of the plating as well as the base metal per procedures in Chapter 5 of TO 1-1-691.
- b. For DEPOT LEVEL maintenance only, reapply nickel plating per SAE AMS-QQ-N-290 (QQ-N-290) to a minimum thickness of 0.5 mils (0.0005 inch) using procedures in TO 42C2-1-7.

#### NOTE

For DEPOT LEVEL maintenance, touch-up of small areas of nickel plating may be accomplished by brush plating per MIL-STD-8651 using procedures in TO 42C2-1-7 in lieu of complete stripping and replating.

- c. Treat the surface with the metal conditioner described in paragraph 7.8 of this manual.



MIL-PRF-23377, TYPE I & II, PRIMER, EPOXY CHEMICAL AND SOLVENT RESISTANT 38



MIL-PRF-85582, PRIMER, EPOXY, WATERBORNE 69



MIL-P-53022, PRIMER, EPOXY, CORROSION INHIBITING, LEAD AND CHROMATE FREE 34



MIL-P-53030, PRIMER, EPOXY, WATER REDUCIBLE, LEAD, CHROME FREE 35

- d. Prime the plated surfaces with one coat of MIL-PRF-23377, Type I, Class C or MIL-PRF-85582, Type I, Class C2 epoxy primers to a DFT of 0.6 to 0.9 mils (0.0006 to 0.0009 inch) or MIL-P-53022 or MIL-P-53030 epoxy primers to a DFT of 0.9 to 1.1 mils (0.0009 to 0.0011 inch), as applicable, from the equipment system specific technical data. Application shall be per procedures in Chapters 4, 5, and 6 of TO 1-1-8.



MIL-PRF-85285, COATING POLYURETHANE, HIGH SOLIDS 50



MIL-DTL-64159, COATING, POLYURETHANE, CHEMICAL RESISTANT, WATERBORNE 24

- e. Apply two coats of either MIL-PRF-85285 standard polyurethane coating or MIL-DTL-64159 waterborne CARC polyurethane coating to a DFT of 1.8 to 3.2 mils (0.0018 to 0.0032 inch) over the primer per procedures in Chapters 4, 5, and 6 of TO 1-1-8. The color and gloss shall match the existing coating system as specified in equipment system specific technical data or as otherwise directed by the equipment SPM.



## TO 1-1-700

7.7.7.2 If surface is not exposed to direct view in its normal operating condition, except while under repair, no further finish over plated surface shall be required. However, plating thickness shall be a minimum of 0.5 mils (0.0005 inch).

7.7.7.3 Where only partial refinishing (touch-up) is required for a few small scratches, nicks, or spots where corrosion was removed on painted surfaces, the following procedure shall be used:

- a. Scuff sand and feather out painted edges and all corroded or scratched surfaces to be refinished per maintenance painting and touch-up procedures in Chapter 5 of TO 1-1-8.
- b. Clean the entire surface to be touched-up of all dust, dirt, oil, and grease by solvent wiping per procedures in Chapter 3 of TO 1-1-8 prior to priming. Apply one coat of the same primers specified in paragraph 7.7.7.1 step d to all surfaces to be touched-up (both those exposed and unexposed to direct view in normal operating conditions) using maintenance painting and touch-up procedures in Chapter 5 of TO 1-1-8.
- c. If surfaces are exposed to direct view in normal operating conditions, apply one coat of the same topcoats specified in paragraph 7.7.7.1 step e over the primer using maintenance painting and touch-up procedures in Chapter 5 of TO 1-1-8. Surfaces not exposed to direct view require no topcoat.

7.7.8 Nickel on Ferrous Base Metal. When complete refinishing is required due to extensive corrosion or loss of film adhesion, disassemble the equipment and/or structure as far as practical. Remove the defective paint system per procedures in Chapter 2 of TO 1-1-8.

7.7.8.1 If surface, when reassembled in its normal operating position, will be exposed to direct view, use the following procedure:

- a. For DEPOT LEVEL maintenance only, strip old plating (copper and nickel) from equipment or part to the base metal per procedures in TO 42C2-1-7. For FIELD LEVEL maintenance and when it is impractical to strip the plating due to size, shape, or connection to other parts, lightly sand areas where corrosion is noted to remove corrosion products of the plating as well as the base metal per procedures in Chapter 5 of TO 1-1-691.
- b. For DEPOT LEVEL maintenance only, reapply copper plating per SAE AMS 2418 (MIL-C-14550) to a minimum thickness of 0.65 mils (0.00065 inch) and nickel plating per SAE AMS-QQ-N-290 (QQ-N-290) to a minimum thickness of 0.5 mils (0.0005 inch) using procedures in TO 42C2-1-7.

- c. Treat the metal surface with the metal conditioner described in paragraph 7.8 of this manual.



MIL-PRF-23377, TYPE I & II, PRIMER, EPOXY CHEMICAL AND SOLVENT RESISTANT 38



MIL-PRF-85582, PRIMER, EPOXY, WATERBORNE 69



MIL-P-53022, PRIMER, EPOXY, CORROSION INHIBITING, LEAD AND CHROMATE FREE 34



MIL-P-53030, PRIMER, EPOXY, WATER REDUCIBLE, LEAD, CHROME FREE 35

- d. Prime the plated surfaces with one coat of MIL-PRF-23377, Type I, Class C or MIL-PRF-85582, Type I, Class C2 epoxy primers to a DFT of 0.6 to 0.9 mils (0.0006 to 0.0009 inch) or MIL-P-53022 or MIL-P-53030 epoxy primers to a DFT of 0.9 to 1.1 mils (0.0009 to 0.0011 inch), as applicable, from the equipment system specific technical data. Application shall be per procedures in Chapters 4, 5, and 6 of TO 1-1-8.



MIL-PRF-85285, COATING POLYURETHANE, HIGH SOLIDS 50



MIL-DTL-64159, COATING, POLYURETHANE, CHEMICAL RESISTANT, WATERBORNE 24

- e. Apply two coats of either MIL-PRF-85285 standard polyurethane coating or MIL-DTL-64159 waterborne CARC polyurethane coating to a DFT of 1.8 to 3.2 mils (0.0018 to 0.0032 inch) over the primer per procedures



in Chapters 4, 5, and 6 of TO 1-1-8. The color and gloss shall match the existing coating system as specified in equipment system specific technical data or as otherwise directed by the equipment SPM.

7.7.8.2 If surface is not exposed to direct view in its normal operating condition, except while under repair, no further finish over plated surface shall be required. However, plating thickness shall be a minimum of 0.65 mils (0.00065 inch) for the copper plating and 0.5 mils (0.0005 inch) for the nickel plating.

7.7.8.3 Where only partial refinishing (touch-up) is required for a few small scratches, nicks, or spots where corrosion was removed on painted surfaces, the following procedure shall be used:

- a. Scuff sand and feather out painted edges and all corroded or scratched surfaces to be refinished per maintenance painting and touch-up procedures in Chapter 5 of TO 1-1-8.
- b. Clean the entire surface to be touched-up of all dust, dirt, oil, and grease by solvent wiping per procedures in Chapter 3 of TO 1-1-8 prior to priming. Apply one coat of the same primers specified in paragraph 7.7.8.1 step d to all surfaces to be touched-up (both those exposed and unexposed to direct view in normal operating conditions) using maintenance painting and touch-up procedures in Chapter 5 of TO 1-1-8.
- c. If surfaces are exposed to direct view in normal operating conditions, apply one coat of the same topcoats specified in paragraph 7.7.8.1 step e over the primer using maintenance painting and touch-up procedures in Chapter 5 of TO 1-1-8. Surfaces not exposed to direct view require no topcoat.

7.7.9 Stainless Steel (CRES). When complete refinishing is required due to extensive corrosion or loss of film adhesion, disassemble the equipment and/or structure as far as practical. Remove the defective paint system per procedures in Chapter 2 of TO 1-1-8.

7.7.9.1 If surface, when reassembled in its normal operating position, will be exposed to direct view and camouflage is required, use the following procedure:

#### NOTE

Stainless steels do not require painting except when they are exposed to view and camouflage is required to restrict the visual signature of the equipment.

- a. Treat the metal surface with the metal conditioner described in paragraph 7.8 of this manual.



MIL-PRF-23377, TYPE I & II, PRIMER, EPOXY CHEMICAL AND SOLVENT RESISTANT 38



MIL-PRF-85582, PRIMER, EPOXY, WATERBORNE 69



MIL-P-53022, PRIMER, EPOXY, CORROSION INHIBITING, LEAD AND CHROMATE FREE 34



MIL-P-53030, PRIMER, EPOXY, WATER REDUCIBLE, LEAD, CHROME FREE 35

- b. Prime the treated surfaces with one coat of MIL-PRF-23377, Type I, Class C or MIL-PRF-85582, Type I, Class C2 epoxy primers to a DFT of 0.6 to 0.9 mils (0.0006 to 0.0009 inch) or MIL-P-53022 or MIL-P-53030 epoxy primers to a DFT of 0.9 to 1.1 mils (0.0009 to 0.0011 inch), as applicable, from the equipment system specific technical data. Application shall be per procedures in Chapters 4, 5, and 6 of TO 1-1-8.



MIL-PRF-85285, COATING POLYURETHANE, HIGH SOLIDS 50



MIL-DTL-64159, COATING, POLYURETHANE, CHEMICAL RESISTANT, WATERBORNE 24

- c. Apply two coats of either MIL-PRF-85285 standard polyurethane coating or MIL-DTL-64159 waterborne CARC polyurethane coating to a DFT of 1.8 to 3.2 mils (0.0018 to 0.0032 inch) over the primer per procedures in Chapters 4, 5, and 6 of TO 1-1-8. The color and gloss shall match the existing coating system as specified in equipment system specific technical data or as otherwise directed by the equipment SPM.

## TO 1-1-700

7.7.9.2 Where only partial refinishing (touch-up) is required for a few small scratches, nicks, or spots where corrosion was removed on painted surfaces, the following procedure shall be used:

- a. Scuff sand and feather out painted edges and all corroded or scratched surfaces to be refinished per maintenance painting and touch-up procedures in Chapter 5 of TO 1-1-8.
- b. Clean the entire surface to be touched-up of all dust, dirt, oil, and grease by solvent wiping per procedures in Chapter 3 of TO 1-1-8 prior to priming. Apply one coat of the same primers specified in paragraph 7.7.9.1 step b to all surfaces exposed to direct view in normal operating conditions that require camouflage being touched-up using maintenance painting and touch-up procedures in Chapter 5 of TO 1-1-8.
- c. Apply one coat of the same topcoats specified in paragraph 7.7.9.1 step c over the primer using maintenance painting and touch-up procedures in Chapter 5 of TO 1-1-8.

7.7.10 Bright Chromium on Ferrous, Copper, and Copper Alloy Base Metals. When complete refinishing is required due to extensive corrosion or loss of film adhesion, disassemble the equipment and/or structure as far as practical. Remove the defective paint system per procedures in Chapter 2 of TO 1-1-8.

7.7.10.1 If surface, when reassembled in its normal operating position, will be exposed to direct view and camouflage is required, use the following procedure:

- a. For DEPOT LEVEL maintenance only, strip old plating from equipment or part to the base metal per procedures in TO 42C2-1-7. For FIELD LEVEL maintenance and when it is impractical to strip the plating due to size, shape, or connection to other parts, lightly sand areas where corrosion is noted to remove corrosion products of the plating as well as the base metal per procedures in Chapter 5 of TO 1-1-691.
- b. For DEPOT LEVEL maintenance only, reapply copper plating on ferrous base metals per SAE AMS 2418 (MIL-C-14538); nickel plating on both copper plated ferrous base metals and copper and copper alloy base metals per SAE AMS-QQ-N-290 (QQ-N-290); and chromium plating on both copper/nickel plated ferrous base metals and nickel plated copper and copper alloy base metals per SAE AMS-QQ-C-320 (QQ-C-320), Class 2 using procedures in TO 42C2-1-7.

**NOTE**

For DEPOT LEVEL maintenance, touch-up of small areas of copper/nickel/chromium plating may be accomplished by brush plating per MIL-STD-8651 using procedures in TO 42C2-1-7 in lieu of complete stripping and replating.

- (1) Copper plating on ferrous base metals shall have a minimum thickness of 0.65 mils (0.00065 inch).
- (2) Nickel plating on copper plated ferrous base metals and copper and copper alloy base metals shall have a minimum thickness of 0.6 mils (0.0006 inch).
- (3) Chromium plating on copper/nickel plated ferrous base metals and nickel plated copper and copper alloy base metals shall have a minimum thickness of 0.3 mils (0.0003 inch).

**NOTE**

Chromium plated surfaces do not require painting except when they are exposed to view and camouflage is required to restrict the visual signature of the equipment.

- c. Treat the plated metal surfaces with the metal conditioner described in paragraph 7.8 of this manual.



MIL-PRF-23377, TYPE I & II, PRIMER, EPOXY CHEMICAL AND SOLVENT RESISTANT 38



MIL-PRF-85582, PRIMER, EPOXY, WATERBORNE 69



MIL-P-53022, PRIMER, EPOXY, CORROSION INHIBITING, LEAD AND CHROMATE FREE 34



MIL-P-53030, PRIMER, EPOXY, WATER REDUCIBLE, LEAD, CHROME FREE 35

- d. Prime the treated plated surfaces with one coat of MIL-PRF-23377, Type I, Class C or MIL-PRF-85582, Type I, Class C2 epoxy primers to a DFT of 0.6 to 0.9 mils (0.0006 to 0.0009 inch) or MIL-P-53022 or MIL-P-53030 epoxy primers to a DFT of 0.9 to 1.1 mils (0.0009 to 0.0011 inch), as applicable, from the equipment system specific technical data. Application shall be per procedures in Chapters 4, 5, and 6 of TO 1-1-8.



MIL-PRF-85285, COATING POLYURETHANE, HIGH SOLIDS

50



MIL-DTL-64159, COATING, POLYURETHANE, CHEMICAL RESISTANT, WATERBORNE

24

- e. Apply two coats of either MIL-PRF-85285 standard polyurethane coating or MIL-DTL-64159 waterborne CARC polyurethane coating to a DFT of 1.8 to 3.2 mils (0.0018 to 0.0032 inch) over the primer per procedures in Chapters 4, 5, and 6 of TO 1-1-8. The color and gloss shall match the existing coating system as specified in equipment system specific technical data or as otherwise directed by the equipment SPM.

7.7.10.2 If surface is not exposed to direct view in its normal operating condition, except while under repair, no further finish is required after plating.

7.7.10.3 Where only partial refinishing (touch-up) is required for a few small scratches, nicks, or spots where corrosion was removed on painted surfaces, the following procedure shall be used:

- a. Scuff sand and feather out painted edges and all corroded or scratched surfaces to be refinished per maintenance painting and touch-up procedures in Chapter 5 of TO 1-1-8.
- b. Clean the entire surface to be touched-up of all dust, dirt, oil, and grease by solvent wiping per procedures in Chapter 3 of TO 1-1-8 prior to priming. Apply one coat of the same primers specified in paragraph 7.7.10.1 step d to all surfaces exposed to direct view in normal operating conditions that require camouflage being touched-up using maintenance painting and touch-up procedures in Chapter 5 of TO 1-1-8.
- c. Apply one coat of the same topcoats specified in paragraph 7.7.10.1 step e over the primer using maintenance painting and touch-up procedures in Chapter 5 of TO 1-1-8.

7.7.10.4 If surface is not exposed to direct view in its normal operating position, except while under repair, no further finish is required after sanding and cleaning procedures in paragraph 7.7.10.3 step a and step b are accomplished if no base metal is revealed. Area shall be primed per paragraph 7.7.10.3 step b if base metal is revealed.

7.7.11 Lead on Copper, Copper Alloy, and Ferrous Base Metals. When complete refinishing is required due to extensive corrosion or loss of plating, disassemble the equipment and/or structure as far as practical; and proceed as follows:

7.7.11.1 Lead plating is used primarily as an anti galling agent in bearing applications and as an aid for soldering. It will not be exposed to direct view in its normal operating condition and it does not require painting after application. Perform replating operations as follows:

- a. For DEPOT LEVEL maintenance only, strip old plating from equipment or part to the base metal per procedures in TO 42C2-1-7. For FIELD LEVEL maintenance, lightly sand areas where corrosion is noted to remove corrosion products of the plating and clean the residue off per procedures in Chapters 3 and 5 of TO 1-1-691. If base metal corrosion is noted, return the equipment to the prime depot for rework.
- b. Lead plate copper or copper alloys per MIL-L-13808, Type II, Class 1 to a minimum thickness of 1.0 mils (0.0010 inch) using procedures in TO 42C2-1-7.
- c. Lead plate ferrous metals after plating with a copper strike plating per MIL-L-13808, Type I, Class 1 to a minimum thickness of 0.015 mils (0.000015 inch) for the copper and a minimum thickness of 1.0 mils (0.0010 inch) for the lead.
- d. No further finish is necessary.

## 7.8 MIL-C-10578 METAL CONDITIONER.



MIL-C-10578, COMPOUND, CORROSION REMOVING AND METAL CONDITIONING

20

MIL-C-10578, Type I (wash off) and Type II (wipe off) corrosion removers and metal conditioners provide excellent surface preparations to promote good paint system adhesion on metals such as zinc galvanize and plating, tin, nickel, and chromium as well as providing minor corrosion protection for these metals in an unpainted condition. Preparation and use of these materials as directed elsewhere in this chapter of this manual shall be per the instructions in Chapter 5 of TO 1-1-691, and all precautions and warning listed therein shall be followed.

### NOTE

MIL-C-10578, Type I and II materials may be obtained through the normal Air Force supply system under NSNs listed in Appendix A of TO 1-1-691.

**TO 1-1-700**

7.8.1 Type I Application. Apply MIL-C-10578, Type I materials per Chapter 5 of TO 1-1-691 and as follows:

- Apply properly prepared Type I (wash off) compound by either spray, dip, or flow-brush.
- Allow the metal conditioner to remain on the metal surface only long enough to cause a dulling of the metal surface appearance.
- Remove metal conditioner by thoroughly rinsing with hot water.
- Paint the item immediately after drying.

7.8.2 Type II Application. Apply MIL-C-10578, Type II materials per Chapter 5 of TO 1-1-691 and as follows:

- Apply properly prepared Type II (wipe off) compound by either rag, sponge, or preferably by brush.
- Allow the metal conditioner to remain on the surface for approximately 30 seconds.
- Wipe residue off with damp and then dry rags leaving a light gray-white film that is ready for painting.
- Paint the item immediately.

**7.9 SPECIAL APPLICATIONS FOR IRON AND STEEL.**

For DEPOT LEVEL maintenance only, in lieu of procedures listed in paragraph 7.7.1, ferrous base metal parts can be finished by one of the following methods:

7.9.1 Finishing. Finish the interior of steel tubing as follows:

- Fill tube with boiled linseed oil conforming to ASTM D 260.
- Pour oil, at a temperature of approximately 160 °F (71 °C), into cleaned interior of tube.
- The tube shall be drained thoroughly and ends sealed air-tight by plugging, welding, brazing, or soldering.
- After cleaning, the exterior of the tube shall be finished per paragraph 7.7.1 of this manual

7.9.2 Screws Used for Wood. Iron or steel screws used exclusively for wood may be given a phosphate coating treatment per TT-C-490, Type I.

7.9.3 Screws Not Used for Wood. Iron and steel screws not used for wood assembly and other iron or steel hardware such as nuts, bolts, washers, clamps etc., shall be zinc or cadmium plated and finished in accordance with requirements for zinc or cadmium plated parts.

7.9.4 Moving Parts. Iron and steel moving parts, such as shafts, gears, etc., when not completely protected against corrosion by an envelope of lubrication, shall be given a manganese phosphate treatment per A-A-59267, Type M (MIL-DTL-16232, Type M, Class 1; use SAE AS 5272/MIL-L-46010, Type II as the supplementary treatment).

7.9.5 Mechanical Use Parts. Steel parts for mechanical use only, on interior surfaces, such as buckets, hooks, eyelets, may be given a zinc phosphate treatment per A-A-59267, Type Z (MIL-DTL-16232, Type Z, Class 2).

**7.10 CHEMICAL FINISHES.**

MIL-PRF-3150, LUBRICATING OIL

31 ■



MIL-PRF-16173, COMPOUND, CORROSION PREVENTIVE

37

ASTM B-633 (QQ-Z-325) zinc plated steel parts for mechanical use only, on interior surfaces, such as buckets, hooks, and eyelets may be finished with a Type III supplementary phosphate treatment in accordance followed by a MIL-PRF-3150 or MIL-PRF-16173, Grade 3 oil coating.

**7.11 SPECIAL CASES.****7.11.1 Threaded Parts.**

7.11.1.1 The minimum thickness of metallic coating on threaded parts shall be 0.2 mils (0.0002 inch), unless otherwise specified.



DOD-L-25681, LUBRICANT, MOLYBDENUM DISULFIDE SILICONE

15

7.11.1.2 External threaded parts shall be coated with either MIL-PRF-83483 thread compound, anti-seize, molybdenum disulfide and petrolatum or DOD-L-25681 lubricant, molybdenum disulfide and silicone oil before installation.

7.11.2 Springs.**WARNING**

Handling hot items presents a serious burn potential. Heat resistant gloves will be worn.

**NOTE**

It is considered advisable to replace all springs having any corrosion which can not be removed readily by rubbing with a cloth.

Springs which have been stripped and/or re-plated shall be baked at 375 °F ±25 °F (191 °C ±14 °C) for 23 hours minimum within 4 hours after removal of the spring from a stripping or plating process to prevent any hydrogen embrittlement caused by exposure to acids used in stripping, pickling, and/or any other plating processes. Springs shall not be flexed prior to baking.

7.11.3 Wood.

- a. Examine wooden cases to determine extent of damage, due to cracking or flaking of painted wood.
- b. Replacement of sections which will affect a repair may be made and new wood sanded and sealed with a clear wood preservative.
- c. Required gluing shall be accomplished prior to sealing operation if practicable, if not, area to be glued and shall be masked.



MIL-P-53022, PRIMER, EPOXY, CORROSION INHIBITING, LEAD AND CHROMATE FREE 34



MIL-P-53030, PRIMER, EPOXY, WATER REDUCIBLE, LEAD, CHROME FREE 35

- d. Prime the surface with one coat of or MIL-P-53022 or MIL-P-53030 epoxy primers to a DFT of 0.9 to 1.1 mils (0.0009 to 0.0011 inch), as applicable, from the equipment system specific technical data. Application shall be per procedures in Chapters 4, 5, and 6 of TO 1-1-8.



MIL-PRF-85285, COATING POLYURETHANE, HIGH SOLIDS 50



MIL-DTL-64159, COATING, POLYURETHANE, CHEMICAL RESISTANT, WATERBORNE 24

- e. Apply two coats of MIL-PRF-85285 standard polyurethane coating, MIL-DTL-64159 waterborne CARC polyurethane coating, or other coating specified by system-specific technical manuals or the equipment SPM to a DFT of 1.8 to 3.2 mils (0.0018 to 0.0032 inch) over the primer per procedures in Chapters 4, 5, and 6 of TO 1-1-8. The color and gloss shall match the existing coating system as specified in equipment system specific technical data or as otherwise directed by the equipment SPM.
- f. Cases which are lightly scratched or in need of repainting shall be lightly sanded and cleaned of dirt, dust, oil or grease, and recoated with polyurethane coating in accordance with paragraph 7.11.3 step e.

7.12 RUST CONVERTERS.

Rust converters typically consist of mixtures of phosphoric acid, organic alcohols, and tannates in a latex matrix that forms a protective film on the metal surface that protects against rust. They are designed to be applied directly to rusty surfaces to convert residual rust on steel surfaces to harmless and adherent chemical compound. Unlike the standard scrape, prime, and paint regime, the surface does not require stripping to bare metal. Rust converters, topcoated with MIL-PRF-85285, serve as a 180-day temporary repair.

7.12.1 Recommended Rust Converter Products.

Neutra Rust 661  
8030-01-369-4416  
8030-01-369-4417

Rust Trapper  
Image 2000 (order by product name)  
P.O. Box 753  
Ione, CA 95640

Rust Reformer (Rust-Oleum)  
11 Hawthorn Parkway  
Vernon Hills, IL 60061

## TO 1-1-700

Extend (Loctite)  
32150 Just Imagine Drive  
Avon, OH 44011

VpCI CorrVerter (Cortec)  
4119 White Bear Parkway  
Saint Paul, MN 55110-7632

7.12.2 Lightly abrade the surface with a Scotch-brite pad, wire brush, sandpaper, or other equivalent material to remove

loose rust only, leave adherent rust on surface, gently wipe abraded area with towel or cloth to remove dust and debris. Apply the rust converter in accordance with manufacturer's instructions. Apply a second coat if required.

7.12.3 After the rust converter has cured per the manufacturer's instruction apply a MIL-PRF-85285 topcoat. Repair area utilizing standard maintenance painting procedures as soon as possible.



## CHAPTER 8

# PREVENTATIVE MAINTENANCE ON ELECTRONIC COMPONENTS

### 8.1 GENERAL.

This chapter outlines corrosion inspection, removal, repair, and protection for electronic components and assemblies. When maintaining communications electronics equipment, it is important that care be given to selecting the proper tools and processes for preventing corrosion, removing corrosion and repairing corrosion-related damage. When treating corrosion, it is especially important to verify that all corrosion has been removed and all factors contributing to the corrosive environment have been eliminated.



**Figure 8-1. ANMST-TIV Corroded Exterior Plugs**

### 8.2 DESCRIPTION.

This chapter describes repair sequence, basic corrosion theory, inspection, corrosion removal, cleaning, surface treatments and handling of specific equipment components. The processes are described as follows:

8.2.1 Paragraph 8.3 provides a brief overview of a general electronics repair process. This process is appropriate for removing corrosion damage.

8.2.2 Paragraph 8.4 provides general corrosion theory and background specific to an electronics context. Properly addressing corroded electronic components requires a good understanding of the science of corrosion prevention and control.

8.2.3 Paragraph 8.5 provides guidance and instructions for inspecting electronic components for corrosion. The importance, in frequent comprehensive inspections in corrosion control, cannot be overstated.

8.2.4 Paragraph 8.6 provides instructions for cleaning electronic components. Electronic components must be clean in order to proceed with corrosion removal, repair, and prevention.

8.2.5 Paragraph 8.7 provides instructions for removing corrosion from electronic equipment. Corrosion must be removed completely while minimizing damage to the surrounding areas.

8.2.6 Paragraph 8.8 provides guidance on selection and application of encapsulates and sealants. Encapsulates and sealants are the two chief ways of protecting electronics against moisture intrusion.

8.2.7 Paragraph 8.9 provides instructions and guidance with respect to specific situations and components common in ground communications electronics.

### 8.3 REPAIR SEQUENCE.

This paragraph provides a step-by-step overview of the corrosion detection, removal, and repair processes.

8.3.1 Inspect Component. The first step in repairing corrosion is inspecting the affected component. This is done to identify the presence, location, and extent of corrosion (or any other kind of damage). This process is described in detail in paragraph 8.5.

8.3.2 Clean Component and Remove Corrosion. Once the component has been inspected, all foreign material must be removed. This includes dirt, corrosion, products of corrosion, solder flux residue, and any other material that has been deposited on the electronics. Paragraph 8.6 gives detailed information regarding the cleaning process. Corrosion removal is covered in detail in paragraph 8.7. Once the component has been cleaned, briefly reinspect to ensure that all corrosion has been removed.

8.3.3 Identify the Conformal Coating. Before any damaged components can be removed and replaced, it is necessary to remove any conformal coating that may be present. There are five principal types of conformal coating defined by MIL-I-46058.

- Acrylic Resin (Type AR)
- Epoxy Resin (Type ER)
- Silicone Resin (Type SR)
- Polyurethane Resin (Type UR)
- Paraxylylene (Type XY)

**TO 1-1-700**

There are three ways to identify the conformal coating. The easiest and most immediate method is through the relevant system specific technical data. The second method is through chemical laboratory analysis of the coating. The final method is a series of tests as described in Section VI of TO 00-25-234.

**8.3.4 Remove the Conformal Coating.** Once the coating has been identified it must be removed. It is essential that the coating be identified correctly. If the wrong removal method is attempted on a coating, it can cause serious damage to the component under repair. Methods for removing each type of conformal coating are described in Section VI of TO 00-25-234. Make sure that the coating is removed completely. There should be absolutely no residue of the coating remaining.

**8.3.5 Repair Damage.** Once any corrosion and conformal coating have been removed, the component or assembly may be repaired. Any circuit component that has suffered corrosion damage must be removed and replaced. Any circuit card that has suffered corrosion damaged must be repaired if possible. If it is not possible to repair the circuit card such that all functionality is restored, it must be replaced. Detailed instructions for the testing and repair of electronics are given in Section V of TO 00-25-234.

**8.3.6 Reapply Conformal Coating.** Once all damage as been repaired, the conformal coating must be reapplied to the component. Before the conformal coating is reapplied, the component should be cleaned of any residue from solder flux or other assembly and repair processes, then rinsed thoroughly in deionized water. Approved methods for applying the coatings are given in Section VI of TO 00-25-234.

## **8.4 ELECTRONIC-SPECIFIC PRINCIPLES AND DESCRIPTIONS.**

This paragraph is intended to provide information about basic corrosion theory as it applies in an electronics context. Knowledge of the science of corrosion prevention and control is essential when repairing corrosion on electronic components.

**8.4.1 Materials and Their Electronic Applications.** In order to prevent and recognize corrosion on electronics, it is necessary to know some of the unique applications that materials have in the context of electronics. Table 8-2 gives some of the common uses of various materials in electronics and electronic components.

**8.4.2 Corrosive Conditions.** Specific conditions that contribute to corrosion are listed in the following paragraphs.

**8.4.2.1 Moisture.** Moisture is the single most common contributing factor to a corrosive environment. Moisture can gain access either in liquid or vapor form. Any areas where air can access the electronics are potential sources of moisture intru-

sion. In addition to the corrosive effects of the moisture, it can contain corrosive contaminants such as chlorides, sulfates, and nitrates.

**8.4.2.1.1 Moisture** whose presence is the result of condensation often evaporates as local temperatures rise. However, this moisture leaves behind residues of contaminants and salts. This residue is especially damaging when it is deposited in close-fitting areas such as faying surfaces. This can happen when the condensed moisture is drawn into close-fitting joints through capillary action.

**8.4.2.1.2** In addition to corrosion, moisture contributes to changes in dimensional stability, dielectric strength, ignition voltages, and insulation resistances.

**8.4.2.2 Salt.** Salts form strong electrolytes when dissolved, which can cause rapid corrosion of metallic materials. The primary source of salt is through water vapor in coastal and shipboard environments.

**8.4.2.3 Other Fluids.** Fuels, hydraulic fluids, lubricants, and coolants can also contribute to corrosion. Even if the fluids are not corrosive to metals, they can cause damage to sealant materials, which can lead to moisture intrusion in the future.

**8.4.2.4 Temperature.** Normal operation of communications electronics equipment frequently produces elevated temperatures. The rate of corrosion, out gassing, and decomposition increases as temperature increases. In addition, elevated temperatures can necessitate increased cooling air circulation, which increases the chances of condensation.

**8.4.2.5 Pollution.** Carbon, nitrates, ozone, sulfur dioxide, and sulfates are some of the pollutants that can be present in the local environments. If these pollutants accumulate, they can combine with moisture to form extremely corrosive solutions.

**8.4.2.6 Sand and Dust.** Sand and dust can also facilitate the creation of corrosive conditions. Airborne sand and dust enter equipment and settle on all surfaces. Once settled, they can trap and hold moisture, creating the conditions for corrosion to begin. In addition, sand is highly abrasive, which can cause damage if it settles on moving or vibrating parts.

**8.4.2.7 Biological Factors (Microorganism, Insect, Animal).** Trapped moisture can create the ideal conditions for the growth of molds, bacteria, and fungi. These organisms tend to trap and hold additional moisture. In addition, some of these organisms' secretions are acidic, and thus strong electrolytes. These organisms can feed on nonmetallic materials commonly present in communications electronics. Even "fungus-resistant" synthetic materials can be vulnerable if they are treated

with a plasticizer or a hardener. The conditions inside electronics assemblies are also very inviting to insects and rodents. These animals can build nests which tend to trap moisture, creating corrosive conditions. Their excrement tends to contain corrosive compounds. Also, insects can feed on electrical insulation, varnishes, and circuit board coatings.

**8.4.2.8 Fumes, Vapors, Residues from Assembly Processes.** Many common assembly, maintenance, or repair processes produce corrosive by-products. Welding, paint spraying, and solvent cleaning all produce vapors that are corrosive to electronics. If adequate ventilation is not present, these fumes can cause or accelerate the corrosion of electronic components. Also, air conditioned environments can contribute to condensation and the presence of excess moisture.

**8.4.2.9 Solder Flux Corrosion.** During soldering, flux must be added to remove the protective oxide layers of the metals being joined. Most of this flux is burned away during the soldering operation. However, some flux can remain and must be cleaned immediately. Residues from solder fluxes can damage electronics by:

8.4.2.9.1 Causing soldered joints to corrode.

8.4.2.9.2 Producing corrosive vapors that settle on adjacent components.

8.4.2.9.3 Attacking insulation, reducing its effectiveness.

8.4.2.9.4 Changing the electrical resistance of soldered joints.

8.4.2.9.5 Attracting dirt and other contaminants that can trap moisture and that may be corrosive.

**8.4.2.10 Equipment Handling.** Equipment removed from its housings for maintenance and repair can become exposed to environments from which it is normally protected. Proper use of protective covers and shipping containers is essential to preventing and minimizing corrosion damage.

**8.4.2.11 Packaging.** Use of proper materials for packaging is essential for the prevention of corrosion damage. Many common packaging materials (some woods, cottons, foams, and papers, for example) absorb moisture. This makes them vulnerable to mold and fungus attacks, as well as permitting moisture to reach the equipment that they should be protecting. Some glues, paints, varnishes, resins, and preservatives can emit corrosive vapors. Some organic materials (adhesives, gaskets, sealants, wire insulation, sleeveings, tubing, plastics, and circuit board varnishes) may outgas corrosive organic acid vapors. If these vapors are released in a confined space (such as inside a container), aggressive corrosion will occur.

**8.4.2.12 Storage.** Electronic equipment should not be stored in wooden boxes, fiberboard containers, or similar packaging.

8.4.2.12.1 Research and experience have shown that the storage of equipment between 40% and 50% relative humidity (RH) provides a dramatic reduction in corrosion. This drives lower failure rates, reduced repair times, and lower costs. Chapter 6, Sections III and IV of NAVAIR 15-01-500 provide background and instructions on implementing dynamic dehumidification in a facility. This allows for the maintenance of 40% to 50% RH.

8.4.2.12.2 Guidelines for the proper packaging of communications electronics equipment for storage are given in Chapter 5 of this manual.

**8.4.2.13 Shipment.** During shipment, equipment can be subjected to environments that it would never experience in service. Often, the equipment was not designed to withstand these conditions. This creates an especially acute corrosion hazard. Changes in altitude, temperature, pressure, vibration, and mechanical shocks can all occur with higher frequency and severity than the equipment would normally experience.

## 8.5 INSPECTION.

A comprehensive inspection program is vital to minimizing corrosion damage to communications electronics equipment. Thorough inspection can detect corrosion early, minimizing its operational and financial impact. This paragraph will focus on the inspection of electronic components. For guidance regarding the inspection of mechanical or structural assemblies, consult Chapter 9 of this manual. Corrosion inspections should be scheduled at regular intervals. In addition, any time an electronics enclosure is open for any reason, a spot check should be performed in order to identify any signs of developing corrosion.

**8.5.1 Corrosion-Prone Areas.** Certain areas of an electronics shelter or enclosure are prone to corrosion. By focusing on these areas, corrosion can be identified more effectively.

**8.5.1.1 Moisture and Fluid Intrusion Sources.** Any area where moisture is likely to intrude is likely to be prone to corrosion. Examples of such areas include doors, access panels, ducts, seals, gaskets, and bulkhead connectors. Any time water penetrates an enclosure, cables and wiring can direct it to electronics that are especially sensitive to corrosion.

**8.5.1.2 Electromechanical.** There are many electronic components that contain moving parts. These include switches, relays, potentiometers, motors, generators, and synchro parts. These parts are especially vulnerable to corrosion while in storage. This is because friction tends to keep the

**TO 1-1-700**

vulnerable surfaces clean while the components are operating. In storage, however, the intrusion of contaminants can cause corrosion to continue unchecked until the component is ruined. Table 8-1 lists common effects of corrosion on electrical components and systems.

**8.5.1.3 Electronic.** Electronic systems are particularly vulnerable to corrosion damage. In modern electronics, circuit

areas are minimized to permit fast operation. Because of this, most circuit paths have a very small cross-sectional area, making them extremely vulnerable to corrosion damage. Often, corrosion that is barely visible to the naked eye is severe enough to impact the operation of a circuit and cause a system failure.

**Table 8-1. Effects of Corrosion on Electronic Equipment**

Component	Failure Mode
Antennas	Shorts, changes in circuit constants, structural deterioration
Relay and switching systems	Mechanical failure, shorts, intermittent operation, signal loss
Plugs, connectors, jacks	Shorts, increased resistance, intermittent operation, water seal deterioration
Power cables	Disintegration of insulation, wire and connector deterioration, shorts
Display lamps	Intermittent operation, electrical failures
Waveguides	Loss of integrity against moisture, pitting, reduction of efficiency, structural deterioration
Printed circuit boards	Shorts, increased resistance, component and system failures
Batteries	High terminal resistance, contact point failure, structural damage to mounting
Bus bars	Structural and electrical failures
Coaxial Lines	Impedance fluctuations, signal loss, deterioration of connectors

**8.5.2 Recognizing Corrosion.** The ability to recognize corrosion is essential to performing a comprehensive corrosion inspection. Metals tend to return to their natural forms (oxides, carbonates, and others) and are thus vulnerable to corrosion. Table 8-2 describes the application of common metals in communications electronics and the indicators of corrosion in those metals. Detailed instructions or guidelines for recognizing corrosion can be found in Chapter 9 of this manual. In most cases, deterioration of nonmetallic components allows moisture intrusion. This contributes to mechanical failure through swelling and cracking. In addition, it contributes to the alteration of the electronic characteristics of electronic components. Table 8-3 describes the type of attack and the appearance of the deterioration for common nonmetallic items in C-E-M equipment.

**8.5.3 Effects of Solder Flux.** Solder flux residues are highly corrosive and may be conductive as well. In addition, they have adhesive properties, attracting and accumulating dirt or other contaminants. In turn, these contaminants may trap moisture, causing corrosion or circuit failure. Ultraviolet light may be used to detect solder flux residue.

**8.5.4 Effects of Microbial Presence.** Bacteria and fungi can feed on organic material (encapsulants, conformal coatings, gaskets, thermoplastics, etc.). Some can release an acid which facilitates additional corrosion. The presence of these microbes can be identified by damp, slimy, and bad-smelling growths on the components in question.

**8.5.5 Effects of Insect and Animal Presence.** Insects and small animals can also feed on some organic compounds. In addition, they can build nests which will trap moisture. The presence of insects or animals can be identified by the presence of nests, holes in packaging, and excrement.

**8.5.6 Inspection Procedures.** This paragraph provides brief guidance with respect to corrosion inspections of communications electronics equipment. For more detailed information, see Chapter 9 of this manual.

**8.5.6.1 General.** Frequent corrosion inspections are essential to minimizing and treating corrosion damage to electronic equipment. Early detection minimizes the cost of repairing corrosion damage.

**8.5.6.2 Water Intrusion.** Technicians should inspect the interior of shelters or enclosures frequently for evidence of water intrusion. Water intrusion will always lead to corrosion. Any evidence of water intrusion or corrosion should be reported so that the appropriate corrective action can be scheduled. The following steps can be used to locate the source of water intrusion:

- a. Verify installation of fasteners. Replace all damaged fasteners.
- b. Inspect form-in-place gaskets. Repair or replace as appropriate.
- c. Verify that all drains are open and operational.
- d. Prepare compartment with “witness material” such as blotter paper or paper towels.
- e. Secure all external openings (doors, air intakes, etc.).
- f. If fresh water is available, apply water to the exterior of the shelter or enclosure for approximately 5 minutes.
- g. Allow 3 to 5 minutes for the water to drain.
- h. Open shelter and examine witness material for signs of water.



MIL-A-46146, ADHESIVE/SEALANT, SILICONE RTV, NON-CORROSIVE, GROUP I/II/III, TYPE I OR GROUP I, TYPE II

19



MIL-PRF-81733, SEALING AND COATING COMPOUND, CORROSION INHIBITIVE

48

- i. If leaks are present, they are to be sealed with MIL-A-46146 or MIL-PRF-81733. If the area is in contact with fluids (coolant, fuel, hydraulic oil), use MIL-PRF-81733.



MIL-PRF-81309, LUBRICANT, CORROSION PREVENTIVE COMPOUND

46

- j. Apply MIL-PRF-81309 to fastener threads as appropriate.
- k. Repeat steps d through j until all leaks are located and eliminated.

**Table 8-2. Materials, Their Electronic Applications, and Corrosion Symptoms**

Material	Typical Applications	Corrosion Symptoms
Iron and Steel	Iron and steel are used for magnetic shields, component leads, transformer cores, brackets, racks, and general hardware. The iron or steel is usually plated with nickel, tin, or cadmium.	Corrosion on iron and steel is easily recognized because it produces red or black rust.
Stainless Steel	Stainless steel is used for brackets, shelves, and mounting hardware. Stainless steel does not corrode in most situations. However, exposure to saltwater can cause pitting. Although stainless steel resists corrosion well, it is susceptible to crevice corrosion.	The corrosion product of stainless steel is a roughened surface with a red, brown, or black stain.
Aluminum	Aluminum is used primarily for structural or housing purposes in electronics. When cleaning corrosion from metallic surfaces, it is essential to remove all corrosion product from adjacent structures. This is because corrosion products of other metals can be corrosive to aluminum.	The corrosion product of aluminum is a white or grey powdery material. The presence of a painted coating is not an indicator that the metal is free of corrosion. Corrosion can occur under the topcoat, eventually causing blisters, flakes, chips, or bumps in the painted surface.

**Table 8-2. Materials, Their Electronic Applications, and Corrosion Symptoms - Continued**

Material	Typical Applications	Corrosion Symptoms
Copper	In electronics, copper is used for contacts, springs, leads, connectors, PCB conductors, and wires. While copper is fairly resistant to atmospheric corrosion, it is anodic to iron, steel, aluminum, and magnesium. This can cause galvanic deterioration in the presence of moisture.	Corrosion of copper usually produces blue-green salts, indicating active surface corrosion. The gray-green crust that frequently forms on copper structures is a protective oxide coating and should not be removed unless it is impairing the functionality of the device.
Cadmium	Cadmium is used as a plating to protect steel items. Cadmium is anodic with respect to steel, and thus is sacrificed when corrosive conditions exist.	Corrosion in cadmium plating produces a white, brown or black mottling on the surface. When this corrosion product is present, it indicates that the cadmium is still protecting the steel underneath. However, when rust appears, the cadmium is no longer providing protection to the steel underneath.
Silver	Silver is used as a plating in a variety of electronic applications.	Silver does not corrode in the conventional sense. It does, however, tarnish, producing a brown to black film. This film should only be removed if it is affecting the performance of the component.
When silver is plated over copper, accelerated deterioration of the copper can occur. The product of this deterioration is called red plague. The product is a red and brown deposit on any exposed copper.		
Gold	Gold is used as a plating in a variety of electronic applications.	Gold is very corrosion resistant and does not normally corrode. Gold will tarnish, however. Removing this tarnish is critical because gold plating is typically applied with a very small thickness. Also, gold plated over copper or silver will accelerate the corrosion of the copper or silver if there are any breaks in the plating. This corrosion is identified as tarnishing of the silver and blue-green deposits on the copper.
Purple Plague is a brittle compound formed when corrosion occurs in a gold-plated aluminum part.		
Tin	Tin is used in solder. Also, tin plating is used on RF shields, filters, crystal covers, and automatic switching devices.	Tin tends to grow "whiskers" on tin-plated wires or leads.
Nickel	Nickel is used as an electroless coating.	Nickel is subject to pitting corrosion. Also, flaking of the nickel can occur as the base material corrodes.

**Table 8-3. Deterioration of Non-Metallic Materials**

Material	Type of Attack to Which Material is Susceptible	Appearance of Deterioration
Acrylic	UV light, moisture solvents	Discoloration, cracking
Adhesive	Dirt, UV light, solvent moisture	Cracking, peeling
Ceramic	Extreme heat	Discoloration, cracking



**Table 8-3. Deterioration of Non-Metallic Materials - Continued**

Material	Type of Attack to Which Material is Susceptible	Appearance of Deterioration
Cloth	Dry rot, mildew	Discoloration, tears, dust
Conformal coating	Moisture, scratches	Peeling, flaking, bubbling
Cork	Moisture, mildew, dry rot	Discoloration, dust, peeling
Elastomer	Heat, UV light, excessive cycling	Cracks, crazing, discoloration
Encapsulation	UV light, moisture	Cracking, peeling, disbonding
Felt	Moisture, mildew	Discoloration, looseness
Glass	Heat, mechanical damage	Cracked, discolored
Laminates	UV light, moisture solvents	Discolored, disbond, delamination
Paint	Moisture, heat, humidity	Bubbles, peeling, cracking
Polymers	Extreme heat, solvents	Discoloration, deformation
Potting compounds	UV light, moisture, heat	Discoloration, cracks, deformation
RTV (non-corrosive)	Moisture, UV light, heat	Peeling, debonding, discoloration
Sealants	Moisture, UV light, heat	Peeling, debonding, discoloration

**8.5.6.3 Evaluation of Damage.** Corrosion damage should be classified as either repairable or non-repairable. Non-repairable damage is damage that exceeds the limits specified in equipment system specific technical manuals. If no limits are present, consult the appropriate engineering authority for disposition of damaged items.

## 8.6 CLEANING

Cleaning is an essential step in performing preventative maintenance and corrosion control on electronic equipment. Thorough cleaning prior to the inspection maximizes the chances that the technician will be able to locate all signs of corrosion.

Once the corrosion has been removed, thorough cleaning minimizes the chances that corrosion byproducts will contaminate the component and facilitate continued corrosion.

**8.6.1 Required Materials and Support Equipment.** It is essential that technicians understand the purpose, function, and applications of all materials and support equipment. Use of incorrect materials or processes can damage equipment, cause corrosion, or aggravate existing corrosion. Table 8-3 contains a list of approved consumable materials. Table 8-4 contains a listing of approved equipment and accessories. Table 8-5 contains recommended methods for cleaning various types of electronic equipment.

**Table 8-4. Electronic Cleaning and Corrosion Removal Consumable Materials**

Item No.	Nomenclature	Specification	National Stock No.	Unit of Issue	Intended Use
ABRASIVES					
1	Abrasive Mat, Aluminum Oxide Abrasive	A-A-58054 Type I, Grade A, Class I (Very Fine) or A-A-58054 Type I, Grade B, Class 1 (Fine)	5350-00-967-5089 5350-00-967-5093	Pkg. of 10, 9" x 6" pads Pkg. of 10, 9" x 6" pads	Aluminum oxide impregnated nylon webbing used for removal of dirt and corrosive products from external avionic chassis, covers, mountings, hardware, antennas, electrical connector shells, etc.

TO 1-1-700

Table 8-4. Electronic Cleaning and Corrosion Removal Consumable Materials - Continued

Item No.	Nomenclature	Specification	National Stock No.	Unit of Issue	Intended Use
ABRASIVES - CONTINUED					
2	Cleaning and Polishing Pad, Non-Abrasive		7920-00-151-6120	Pkg. of 10, 5" x 11" pads	Avionic washing pad used for removal of dirt and contaminants from internal avionic structures, laminated circuit boards, waveguides, TR tubes, cavities, circuit components, relay contacts, control box face-plate, etc.
3	Cloth, Abrasive Aluminum Oxide	ANSI-B74.18 320 Grit, Type I, Class 1; Type I, Class 2; Type I, Class 2	5350-00-246-0330 5350-00-187-6289 5350-00-229-3092	Pkgs., 50 sheets, 9" x 11" Roll, 2" x 50 yd. Roll, 3" x 50 yd.	<div style="text-align: center;"><b>CAUTION</b></div> <p>Do not use Silicon Carbide Abrasive Cloth, ANSI-B74.18.</p> <p>Removal of heavy corrosive products from steel, iron, aluminum, and magnesium structures, mountings, racks, chassis, covers, scuff sanding of avionic boxes prior to painting, etc.</p>
4	Eraser, Magic Rub, Plastic	(Block Shape)	7510-00-949-5055	Doz., 2" x 5/8" x 1/2"	<div style="text-align: center;"><b>CAUTION</b></div> <p>Only to be used if component is sufficiently rigid to resist rubbing motion.</p> <p>Removal of light tarnish on silver. Removal of light corrosion on copper, zinc, nickel, etc. For brightening of gold.</p>
5	Eraser, Ruby Red	(Block Shape)	7510-00-223-7046	Doz., 2-1/4" x 1-1/8" x 11/16"	<div style="text-align: center;"><b>CAUTION</b></div> <p>Only to be used if component is sufficiently rigid to resist rubbing motion.</p> <p>Removal of medium tarnish on silver. Removal of medium corrosion on copper, zinc nickel, etc. For brightening of gold.</p>

Table 8-4. Electronic Cleaning and Corrosion Removal Consumable Materials - Continued













Item No.	Nomenclature	Specification	National Stock No.	Unit of Issue	Intended Use
<b>ABRASIVES - CONTINUED</b>					
6	Eraser, Wood or Paper Encased	(Pencil Shape)	510-00-582-3756	7 Doz., 7" x 3/16" dia.	<div style="text-align: center;"></div> <p>Care should be taken not to remove thinly plated surfaces.</p> <p>Removal of medium tarnish and corrosion products in tight areas.</p>
7	Eraser, Typewriter	(Pencil Shape)	7510-00-619-7714	Doz., 6" x 3/16" dia.	<div style="text-align: center;"></div> <p>Care should be taken not to remove thinly plated surfaces.</p> <p>Removal of heavy tarnish on silver. Removal of heavy corrosion on copper, zinc, nickel, etc. For brightening of gold.</p>
<b>CLEANING COMPOUNDS AND SOLVENTS</b>					
 MIL-D-16791, DETERGENT, NON-IONIC <span style="float: right;">22</span>					
   MIL-PRF-85570, CLEANING COMPOUND, AIRCRAFT <span style="float: right;">51</span>					
     TT-I-735, ALCOHOL, ISOPROPYL <span style="float: right;">65</span>					
					
Cleaning solvents may react with coatings and circuit components. When in doubt as to reaction, test the affected area prior to wholesale application of the solvent.					
8	Detergent, Liquid Nonionic	MIL-D-16791, Type I	7930-00-282-9699 7930-00-985-6911	Can, 1 gal. Can, 5 gal.	For cleaning and polishing transparent plastic and glass.  <div style="text-align: center;"><b>NOTE</b></div> <p>Mix 1 oz. per gal. water. Apply with cloth, cotton flannel, A-A-50129, Type II. When dry, wipe with dry flannel cloth. Also used as a detergent in the Aqueous Ultrasonic Cleaner and Aqueous Spray Cleaning Booth.</p>

Table 8-4. Electronic Cleaning and Corrosion Removal Consumable Materials - Continued

Item No.	Nomenclature	Specification	National Stock No.	Unit of Issue	Intended Use
CLEANING COMPOUNDS AND SOLVENTS - CONTINUED					
9	Cleaning Compound	MIL-PRF-85570, Type II	6850-01-235-0872	Can, 5 gal.	General cleaning. For removal of soil and fire extinguishing chemicals. Excellent cleaner for light oils and hydraulic fluids. It can be used in areas of reduced ventilation.
10	Cleaning Solvent	Envirosolv 654CR Vertrel PD-108 Ethyl Lactate/Mehtyl Soyate (Vertec) Novec Engineered Fluids	6850-01-388-9803 6850-01-388-9732 open purchase open purchase open purchase		For use in ultrasonic cleaning. Or as wipe solvent. For use as wipe solvent for cleaning electronics. For use as wipe solvent for heavy oils and greases. For parts cleaning and degreasing. These fluids contain hydrofluorocarbon solvents for cleaning/degreasing. Cleaning electrical contacts. Use as wipe solvent or as spray.
11	Cleaning Compound, Avionics components non-ozone depleting	MIL-PRF-29607			Used for aqueous avionic cleaner designed for batch cleaning processes. It can be used in heated (up to 140 °F) or unheated tanks. Parts must be rinsed well and air dried or dried in a force draft oven at 120 °F.
12	Cleaning and cleaning-lubricating compounds, electrical contact, low ozone depletion potential	MIL-PRF-29608 Type I or II, Class C and L Type I, Class C	6850-01-412-5579 (open purchase)	12 oz. aerosol can	Used for the cleaning of electrical contacts and switches. It is intended for the removal of aircraft avionics soils, salt, dielectric fluid and hydraulic fluid. Class C is used for cleaning of electrical contacts.
13	Isopropyl Alcohol	TT-I-735	6810-00-286-5435 6810-00-855-6160 6810-00-983-8551 6810-00-753-4993	Can, 1 gal. Can, 5 gal. Can, 1 qt. Can, 8 oz.	<div style="border: 1px solid black; padding: 2px; display: inline-block; margin-bottom: 10px;"><b>WARNING</b></div> <p>Flash point is 53 °F (12 °C).</p> <p>For removal of fungus and bacteria. For removal of solder flux residue. For removal of contaminants on microminiature circuit components. For general cleaning and removal of salt residue and contaminants on circuit components.</p>

Table 8-4. Electronic Cleaning and Corrosion Removal Consumable Materials - Continued



Item No.	Nomenclature	Specification	National Stock No.	Unit of Issue	Intended Use
<b>CORROSION PREVENTIVE COMPOUNDS (PRESERVATIVE)</b>					
					
MIL-PRF-81309, LUBRICANT, CORROSION PREVENTIVE COMPOUND 46					
					
MIL-DTL-85054, COMPOUND, CORROSION PREVENTIVE 25					
					
MIL-PRF-16173, COMPOUND, CORROSION PREVENTIVE 37					
<div style="border: 1px solid black; padding: 5px; display: inline-block;"><b>WARNING</b></div>					
Do not use Corrosion Preventative Compounds around oxygen, oxygen fittings, or oxygen regulators, since fire or explosion may result.					
14	Corrosion Preventative Compound, Water-Displacing, Ultra-thin Film, Avionics Grade	MIL-PRF-81309 Type II or III, Class 2 (Aerosol) Class 1 (Bulk)	8030-00-546-8637 8030-00-262-7358 8030-00-524-9487	Aerosol can, 16 oz. Can, 5 gal. Drum, 55 gal.	Water-displacing corrosion preventive on highly critical metal surfaces. For use on electrical connectors in interior areas.
15	Corrosion Preventative Compound, water-displacing, clear	MIL-DTL-85054, Type I, Class Optional Type II	8030-01-066-3971 8030-01-347-0981	Can, 12 oz. Can, 1 qt.	For corrosion prevention on metals, on paint, scratches, or other areas of bare metal. Not for use around oxygen lines, fittings or gauges.
16	Corrosion Preventative Compound, Solvent Cutback Cold Application	MIL-PRF-16173, Grade 4 (Transparent Film)	8030-00-526-1605 8030-00-062-5866 8030-00-903-0931	Can, 5 gal. Can, 1 gal. Can, 1 pint	Preservative material, thin, transparent film. For use on equipment racks, mounts, exposed hardware, etc. For use on exterior surfaces of electrical plugs and connectors. Not intended as a water-displacing compound.

Table 8-4. Electronic Cleaning and Corrosion Removal Consumable Materials - Continued





Item No.	Nomenclature	Specification	National Stock No.	Unit of Issue	Intended Use
LUBRICATING OILS AND GREASES					
					
		MIL-PRF-32033, LUBRICATING OIL, GENERAL PURPOSE, PRESERVATIVE (WATER-DISPLACING, LOW TEMPERATURE)			41
					
		MIL-PRF-81322, GREASE, AIRCRAFT GENERAL PURPOSE			47
					
		MIL-L-23398, LUBRICANT, SOLID FILM			30
17	Lubricating Oil, General Purpose, Preservative (Water-Displacing)	MIL-PRF-32033	9150-00-231-9062 9150-00-231-6689 9150-00-273-2389 9150-00-458-0075	Can, 5 gal. Can, 1 qt. Can, 4 oz. Aerosol can, 16 oz.	General lubrication and protection of avionic components, hinges, and quick release devices. Suitable for use where a general purpose lubricating oil with low temperature and corrosion preventive properties is desired.
18	Grease, Instrument, Ultra-clean	MIL-G-81937	9150-01-009-6235	Tube, 4 oz.	For lubrication of bearings in instruments and related components such as synchros and gyros. Ideally suited for bearings, having small tolerances with respect to clearance.
19	Lubricating Oil, Instrument, Ball Bearing, High Flash Point	DOD-L-81846	9150-00-238-5203	Bottle, 4 oz.	For use in precision instruments and miniature ball bearings. Temperature range of -65 °F (-54 °C) to 302 °F (150 °C).
20	Grease, Aircraft, General Purpose, Wide Temperature Range	MIL-PRF-81322	9150-00-145-0268 9150-00-181-7724	Can, 5 lb. Tube, 8 oz.	For use on blower motors, servomotors and gyro spin motors.



Table 8-4. Electronic Cleaning and Corrosion Removal Consumable Materials - Continued

Item No.	Nomenclature	Specification	National Stock No.	Unit of Issue	Intended Use
<b>LUBRICATING OILS AND GREASES - CONTINUED</b>					
21	Lubricating, Solid Film, Air-Cured, Corrosion Inhibiting	MIL-L-23398	9150-00-954-7422 9150-00-754-0064	Can, 1 qt. Aerosol can, 12 oz.	<div style="text-align: center;"></div> <p>Not to be used in operations consisting of rotary motion over 100 RPM under heavy loads where the possibility of conventional fluid lubricants contamination exists. Not to be used on bearings containing rolling elements.</p> <p>For use on aluminum, aluminum alloys, copper and copper alloys, steel, stainless steel, titanium, and chromium and nickel bearing surfaces. For use on sliding motion applications such as locks, small internal cables, plain and spherical bearings, flap tracks, hinges, threads, and cam surfaces. For use in mechanisms that are lubricated for life and in mechanisms operated at in-frequent intervals.</p>
<b>CLEANING CLOTHS</b>					
22	Cloth, Non-Woven Fabric	A-A-162, Class 7	7920-01-180-0556	Box 2700/pkg.	<div style="text-align: center;"></div> <p>Not approved for use in wiping plastic and acrylic surfaces with solvents having a flash point of less than 100 °F (38 °C).</p> <p>No lint, extra heavy duty, moderate wet strength, good absorbency, and disposable. For use when good wet strength and short term rewetting is required, and for wiping critical avionic equipment.</p>

TO 1-1-700

Table 8-4. Electronic Cleaning and Corrosion Removal Consumable Materials - Continued

Item No.	Nomenclature	Specification	National Stock No.	Unit of Issue	Intended Use
CLEANING CLOTHS - CONTINUED					
23	Cloth, Cleaning, Lint-free	A-A-59323 Type I A-A-59323 Type II	7920-00-165-7195 7920-00-044-9281	Box, 10 lb. Box, 10 lb.	<div style="text-align: center;"></div> <p>Not authorized to be used with solvents having flash points of less than 100 °F (38 °C); such use may result in fire.</p> <p>Very low lint, relatively low absorbency, good wet strength, intended for wash and reuse. For use on critical surfaces where low contamination levels are required. Type I preferred for clean room applications.</p>
24	Cheesecloth, 100% Cotton	A-A-1491	8305-00-267-3015 8305-00-205-3496 8305-00-205-3495	Bolt, 1 yd. Bolt, 10 yd. Bolt, 100 yd.	Moderate lint, high absorbency, and disposable. For general cleaning on external surfaces of avionic equipment. For use as tack rag and final wipe prior to painting.
25	Cloth, Flannel	A-A-50129	8305-00-641-5606	Bolt, 50 yd.	<p>High lint, high absorbency, high wet strength, reusable after washing, and disposable. For use on cockpit indicator glass covers, plastic and acrylic control panels.</p> <p style="text-align: center;"><b>NOTE</b></p> <p>Only authorized cloth to be used for cleaning plastic and acrylics with solvents with a flash point less than 100 °F (38 °C).</p>

Table 8-4. Electronic Cleaning and Corrosion Removal Consumable Materials - Continued





Item No.	Nomenclature	Specification	National Stock No.	Unit of Issue	Intended Use
<b>SEALANTS</b>					
					
		MIL-A-46146, ADHESIVE/SEALANT, SILICONE RTV, NON-CORROSIVE, GROUP I/II/III, TYPE I OR GROUP I, TYPE II			19
					
		AMS-S-83318, SEALING COMPOUND, LOW TEMPERATURE CURING			10
					
		MIL-PRF-81733, SEALING AND COATING COMPOUND, CORROSION INHIBITIVE			48
					
		MIL-PRF-8516, TYPE II, SEALING COMPOUND, POLYSULFIDE RUBBER			49
					
RTV silicone sealants, adhesives, and coatings that contain acetic acid curing agents are not authorized for use in electronic equipment.					
26	Adhesive-Sealant, Silicone, RTV, Non-Corrosive, 3145 RTV	MIL-A-46146	8040-00-145-0020 8040-00-938-1535	Tube, 3 oz. Kit, 12 oz. Kit	For use on sensitive metals and avionic equipment. Sealing areas where temperature is expected to be between 250 °F (121 °C) and 350 °F (177 °C).
27	Sealing Compound	AMS-S-83318	8030-00-474-1419	Kit, 6 oz.	A quick cure sealant that contains corrosion inhibitor. For use in sealing gaps, seams, etc. during extreme cold weather activities.
28	Sealing and Coating Compound, Corrosion Inhibitive	MIL-PRF-81733, Grade B Class Optional (Brush application)	8030-00-753-5009 8030-00-723-5343 8030-00-723-5344	Kit, 6 oz. Kit, 1 pt. Kit, 1 qt.	Sealing of gaps, seams and faying surfaces on high performance aircraft. For use up to 250 °F.

Table 8-4. Electronic Cleaning and Corrosion Removal Consumable Materials - Continued



Item No.	Nomenclature	Specification	National Stock No.	Unit of Issue	Intended Use
<b>POTTING COMPOUND</b>					
					
Potting Compounds Pro-Seal 777A/B (Green) and EC-2773 (black) revert to liquid after a year or two, depending on environment, and are not authorized for use in electrical connectors electronic equipment.					
29	Sealing Compound, Synthetic Rubber, Accelerated	MIL-PRF-8516, Type II (24 hr. cure) (48 hr. cure) (72 hr. cure)	8030-00-881-2618 8030-00-181-7884 8030-00-881-5238 8030-00-297-6677 8030-00-174-2597 8030-00-616-7696 8030-00-684-8790	Kit, 2.5 oz. Kit, 6 oz. Kit, 1 qt. Kit, 1/2 pt. Kit, 1 qt. Kit, 1/2 pt. Kit, 1 qt.	  Not authorized for use in engine bays, keel areas or areas adjacent to bleed air ducts.  For sealing low voltage electrical connectors, wiring and other electrical apparatus against moisture and corrosion where temperature does not exceed 200 °F (93 °C). Good resistance to gasolines, oils, grease, water and humidity.
<b>MASKING MATERIALS AND TAPES</b>					
30	Preservation and Sealing Tape, Pressure Sensitive Adhesive	SAE-AMS-T-22085 Type II	7510-00-852-8179 7510-00-852-8180 7510-00-926-8939 7510-00-916-9659	Roll, 1" Roll, 2" Roll, 3" Roll, 4"	For holding barrier material in place during shipping. Treated, non-corrosive, non-fungus supporting. For use on equipment without overcoatings.
31	Tape, Pressure Sensitive Adhesive, paper Masking, Nonstaining	SAE-AMS-T-21595, Type I	7510-00-680-2450 7510-00-685-4963 7510-00-680-2395 7510-00-680-2471	Roll, 1/2" x 60 yd. Roll, 1" x 60 yd. Roll, 2" x 60 yd. Roll, 3" x 60 yd.	  Only to be used if components sufficiently rigid to stand application of tape and removal.  For masking of undamaged areas during paint touch-up on equipment cases, covers, mounting rack, etc. For masking electrical and electronic components during replacement of conformal coating and varnishing.

Table 8-4. Electronic Cleaning and Corrosion Removal Consumable Materials - Continued

Item No.	Nomenclature	Specification	National Stock No.	Unit of Issue	Intended Use
<b>MASKING MATERIALS AND TAPES - CONTINUED</b>					
32	Tape, Pressure Sensitive Adhesive for Masking During Paint Stripping Operations	SAE-AMS-T-23397, Type II	7510-00-473-9513	Roll, 2" x 60 yd.	For masking during paint stripping operations on avionic equipment and airframe structures.
33	Tape, Pressure Sensitive	A-A-59298	7510-00-472-4021	Roll, 1" x 72 yd.	For isolating dissimilar metals where galvanic action may take place in avionic equipment.
34	Insulating Tape Electrical, Self Bonding, Silicone	604-1 Black 604-2 Red	5970-00-955-9976 5970-00-949-4846	Roll Roll	For insulating connectors from severe environments, such as wheel wells, wing butts, or bilges.
35	Paper, Kraft, Untreated Wrapping	A-A-203	8135-00-160-7766 or 8135-00-290-3407 8135-00-160-7771	Roll, 24" x 820' Roll, 24" x 980' Roll, 36" x 700'	Protection of surrounding areas during paint spray operations.
<b>CONFORMAL COATING</b>					
 <p>MIL-A-46146, ADHESIVE/SEALANT, SILICONE RTV, NON-CORROSIVE, GROUP I/II/III, TYPE I OR GROUP I, TYPE II 19</p> <p style="text-align: center;"><b>NOTE</b></p> <p>Materials listed are for general purpose use in conformal coated circuit boards. For special applications on highly critical components, refer to the appropriate equipment manual.</p>					
36	Epoxy Coating, Two Part Application	Hysol 0151	8040-00-061-8303	Kit, each	For coating and patching epoxy and parylene coated circuit boards and components.
37	Polyurethane Coating (Brush Application)	Humiseal 1A27	5970-00-995-3652 5970-01-036-4488	Can, 1 qt. Can, 12 oz. aerosol	For coating and patching polyurethane and varnish coated circuit boards and components.
38	RTV Coating Nonflowable (Brush Application), 738 RTV (White)	MIL-A-46146	8040-00-118-2695	Tube, 3 oz.	For coating and patching RTV coated circuit boards and components.  <b>NOTE</b> Not flowable into crevices and hard to reach areas.

Table 8-4. Electronic Cleaning and Corrosion Removal Consumable Materials - Continued





Item No.	Nomenclature	Specification	National Stock No.	Unit of Issue	Intended Use
<b>CONFORMAL COATING - CONTINUED</b>					
39	RTV Coating, Flowable (Brush Application), 3140 RTV (Clear)	MIL-A-46146	5970-00-110-8234 5970-00-791-3716	Can, 1 lb. Tube, 3 oz.	For coating and patching RTV coated circuit boards and components.  <b>NOTE</b> Use in applications where a flowable material is required such as potting connectors.
40	Acrylic Coating	Humiseal IB15H	5790-00-990-4924	Aerosol can, 16 oz.	For coating and patching of acrylic and lacquer coated circuit boards and components.
					
ASTM D 3955 (MIL-V-173), VANISH, ELECTRICAL INSULATING 12					
41	Varnish	ASTM D 3955	8180-00-180-6343 5970-00-285-0269 5790-00-285-0271	Can, 1 qt. Can, 5 gal. Can, 1 gal.	Moisture and fungus resistant varnish for electrical equipment and for clear coating on copper. For coating and patching of varnish coated circuit boards. Thinner: Thinner, Synthetic, Resin, Enamels, A-A-3007.
<b>NEUTRALIZING AGENTS</b>					
					
ASTM D 928, SODIUM BICARBONATE 13					
					
MIL-DTL-81706 (ALODINE), COATING, CHEMICAL CONVERSION 23					
					
A-A-59282, ACID, BORIC 7					
42	Sodium Bicarbonate, Technical	ASTM D928	6810-00-264-6618 6810-00-290-5574	Box, 1 lb. Bag, 100 lb.	For neutralizing spilled sulfuric acid (electrolyte) in lead acid battery installations. For neutralizing leaking tantalum capacitors in avionic equipment.



Table 8-4. Electronic Cleaning and Corrosion Removal Consumable Materials - Continued

Item No.	Nomenclature	Specification	National Stock No.	Unit of Issue	Intended Use
NEUTRALIZING AGENTS - CONTINUED					
43	Sodium Phosphate, Monobasic, Anhydrous, Technical	AWWA-B504	6810-00-281-1858	Bag, 100 lb.	For neutralizing spilled potassium hydroxide (electrolyte) in nickel-cadmium and silver-zinc battery installations. Also used as abrasive material in the Mini-Abrasive Unit.
44	Chemical Conversion Material for Coating Aluminum and Aluminum Alloys Touch-n-prep pen	MIL-DTL-81706 Class 1A Class 3 (Avionic Grade)	8030-00-142-9272 8030-00-823-8039 8030-01-460-0246	Can, 1 pt. Can, 1 gal. Can, 1 lb.	Treatment of bare aluminum. For all small touch up.
45	Chemical Conversion Material for Coating Magnesium Alloy	SAE-AMS-M-3171 Type VI (Macro Mag D-19)	(Available from MacDermid Inc., Waterbury, CT)	Bottle, 1 pt.	Treatment of bare magnesium.
46	Boric Acid	A-A-59282	6810-00-264-6535	lb.	For neutralizing electrolyte leakage from nickel-cadmium batteries.
TRACER					
47	Indicator, Thymol Blue Reagent	A-A-59282	6810-00-664-1622	Bottle, 25 ml	For detecting reverse voltage damage to wet-slug tantalum capacitors. (Dissolve 1/4 teaspoon of Indicator in three 8-oz. cups of deionized or distilled water to which eight drops of Ammonium-Hydroxide, O-A-451 has been added.) Also used as a Nicad electrolyte indicator.
48	Litmus Paper	Blue Litmus Paper Red Litmus Paper	6640-00-290-0146 6640-00-290-0147	HD(100) HD(100)	Color change to red indicates acid present (lead acid batteries) Color change to blue indicates alkali (base) present (nickel cadmium batteries).
49	Desiccant, Bagged	MIL-D-3464, Grade A	6850-00-264-6754 6850-00-264-6571 6850-00-264-6572	Drum, 500 each 4-unit bags Drum, 300 each 8-unit bags Drum, 150 each 16-unit bags	Absorbs moisture, lowers relative humidity when sealed in container.

TO 1-1-700

**Table 8-4. Electronic Cleaning and Corrosion Removal Consumable Materials - Continued**

Item No.	Nomenclature	Specification	National Stock No.	Unit of Issue	Intended Use
TRACER - CONTINUED					
50	Humidity Indicators	MS20003	6685-00-752-8240	Can, 125 cards	Used to determine that desiccant, within a package, is sufficiently active to maintain a relative humidity below that at which corrosion will occur.
51	Water, Distilled		6810-00-107-1510	Container, 5 gal.	Used for cleaning in critical soldering operations.
52	Ammonium Hydroxide, Technical	A-A-59370	6810-00-584-3793	Bottle, 1 pt.	Used to assist in dissolving Indicator, Thymol Blue Reagent, A-A-59282.
53	Glass Beads	SAE AMS 2431/6	5350-00-576-9634	Bag, 50 lb.	Used as abrasive in hand-held tool in Blast Cleaning Cabinet.
54	Silver Nitrate	A-A-59282	6810-00-282-1218	1 lb.	Identification of magnesium metal.
55	Silver Nitrate, Solution		6810-00-233-0126	Bottle, 4 oz.	Identification of magnesium metal.
56	Damping Fluid	VV-D-1078 Grade 100/100K cs	9150-00-269-8246	5 gal.	Lubricant for use on small switches and potentiometers where a residual lubricant is required after cleaning.

**Table 8-5. Accessories of Electronic Cleaning and Corrosion Control**

Item No.	Nomenclature	Specification	National Stock No.	Unit of Issue	Intended Use
1	Brush, Acid, Swabbing	A-A-289 Style opt.	7920-00-514-2417	Box of 144 (3/8" x 6")	For cleaning connectors, circuit boards, and small components.
2	Brush, Paint, Metal, Bound Flat		8020-00-263-3866	Each	For paint touch-up. For removal of dirt and soil.
3	Brush, Artist's		8020-00-224-8022	Each	For touch-up of small areas of paint damage
4	Toothbrush		8530-01-293-1387	Dz	For scrubbing dirt, soil, and corrosive products from circuit components.
5	Brush, Typewriter	A-A-3077, Style 1	7510-00-550-8446	Each	For scrubbing dirt, soil, and corrosive products from circuit components.
6	Pipe Cleaners		9920-00-292-9946	Pkg. of 32	For removal of cleaning solvent residues in hard to reach crevices and corners of small components.

Table 8-5. Accessories of Electronic Cleaning and Corrosion Control - Continued

Item No.	Nomenclature	Specification	National Stock No.	Unit of Issue	Intended Use
7	Applicator, Disposable, Cotton Tipped		9515-00-303-8250	Pkg. of 100	For removal of cleaning solvent residues on microminiature circuit boards, coaxial connectors, etc.
8	Face shield, Industrial	ANSI Z87.1	4240-00-542-2048	Each	Eye and face protection while using solvents.
9	Goggles, Industrial and Spectacles, All Plastic	ANSI Z87.1	4240-01-243-5805	Pair	Eye protection while using solvents.
10	Gloves, Rubber, Industrial (Synthetic)	MIL-DTL-32066	8415-00-266-8679 8415-00-266-8677	Pair, size 8, small Pair, size 9, medium	Handling of solvents, paint strippers, or other materials which may be injurious to the skin.
11	Magnifying Glass		6650-00-958-7408 6650-00-431-4375	10x illuminated 14x folding	Detailed inspection of corrosion cracks and small surface corrosion damage.
12	Pump, Backpack		4320-00-289-8912	5 gal.	Localized cleaning of shelter or enclosure surfaces.
13	Respirator (without cartridge)	465825 (Small) 460968 (Medium) 466486 (Large)	4240-01-150-7937 4240-01-022-8501 4240-01-086-7670	Each Each Each	Personnel protection from organic vapors, dust, and paint sprays in non-confined areas during spraying operations.
14	Respirator parts: Cartridge, Organic vapor Prefilter Retainer for prefilter	464031 465667 448844	4240-01-230-6892 4240-01-231-0150 4240-01-020-8782	Box Box Each	For use with above respirators.
15	Vacuum Cleaner, Air Operated			Each	Removal of dirt and debris from circuit cards, enclosures, and shelters.
16	Sound Attenuators Aural	SAE AS23899	4240-00-759-3290	Each	<div style="border: 1px solid black; padding: 5px; display: inline-block; margin-bottom: 10px;"><b>WARNING</b></div> <p>Earplugs required in addition to sound attenuators. Contact local medical officer.</p> <p>Ear protection while using ultrasonic cleaners.</p>
17	Coveralls, Green	MIL-C-2202	8405-00-131-6507 8405-00-131-6508 8405-00-131-6509 8405-00-131-6510 8405-00-131-6511	Small Medium Large X-Large XX-Large	Corrosion maintenance personnel.

Table 8-5. Accessories of Electronic Cleaning and Corrosion Control - Continued

Item No.	Nomenclature	Specification	National Stock No.	Unit of Issue	Intended Use
18	Hot Air Gun, Thermogun MODEL 500A	A-A-59435	4940-00-028-7493	Each	<p><b>WARNING</b></p> <p>Not explosion proof.</p> <p>For drying equipment and circuit components in shop.</p>
19	Hot Air Gun Raychem	(Part Number HT-900)	(Available from Ray Chem Corp.)	Each	For drying equipment and components.
20	Spatula	A-A-277	7330-00-680-2636	Each	For application of sealing compound, MIL-PRF-81773, Type II.
21	Mirror, Inspection	GGG-M-350	5120-00-278-9926 5120-01-313-4097	Each, 1-1/4" x 1-1/2" Each, 1" x 2" x 9"	For inspecting inaccessible areas for corrosion damage and cleaning solvent residues.
22	Pail, Rubber	A-A-59253	7240-00-246-1097	Each, 3 gal.	For hand cleaning operations.
23	Stencil Marking Sets		7520-00-205-1760 7520-00-272-9680 7520-00-298-7043	1/2" set 1-1/2" set 1" set	For equipment marking
24	Bottle, Plastic Manual Spray Atomizer		8125-00-488-7952	Each, 1 pint	For manual spray application of cleaners and solvents.
25	Beaker, Polyethylene (600 cc)		6640-00-889-1834	Each	For mixing primers, paints, and hand cleaning small components by immersion.
26	Dispenser, Alcohol		3439-00-552-9309	Each	For application of cleaning solvents in microminiature shops and electronics shops. Self-sealing top prevents contamination of fluid from particles, dust, etc., in the atmosphere.
27	Ultraviolet Light, Portable		6635-00-611-5617	Each	<p><b>WARNING</b></p> <p>Use with the filter provided in the kit. Ultraviolet light can be harmful to the eyes. Do not use a cracked, damaged, or undersized filter.</p> <p>For detecting solder flux on miniature and microminiature circuit boards.</p>

Table 8-5. Accessories of Electronic Cleaning and Corrosion Control - Continued

Item No.	Nomenclature	Specification	National Stock No.	Unit of Issue	Intended Use
28	Sealing Machine, Electric Jaw Type, Portable (6" Jaw)		3540-00-293-0377	Each	Used on heat-sealable, flexible, transparent/translucent packaging films.
29	Booth, Cleaning, Water Base Solvent Spray		4940-00-422-1774	Each	For the removal of dirt, dust, salt spray deposits and light corrosion products. For pre-cleaning of components prior to ultrasonic detergent cleaning. For cleaning and rinsing components after ultrasonic detergent cleaning, abrasive corrosion removal and hand cleaning.
30	Drying Oven, Circulating Air	Model 46	4430-01-009-2371 4430-01-097-5087	Each	For drying electronic equipment and components through circulating air and temperature.
31	Drying Oven, Forced Air		4430-01-097-5087 4430-01-097-5088 4430-01-009-2371 4430-01-010-7052	Each	For drying electronic equipment and components through exhausted forced air and temperature.
32	Portable Steam Cleaner		4940-01-411-8632 4940-01-409-0149 4940-01-411-3278		Associated accessories, cleaning solutions and rust inhibitors shall be ordered as needed. For use in cleaning circuit cards and other PWBs.
33	Cabinet, Blast, Cleaning		4940-00-242-3631	Each	<div style="text-align: center;"><b>CAUTION</b></div> <p>Do not use on static sensitive devices and microminiature components. Do not use same blast media for removal of corrosion products on ferrous metals and nonferrous aluminum alloys.</p> <p>Provides a shielded enclosure for portable honer operation. Used for abrasive cleaning of rust and corrosion products from electronic equipment enclosures and housings.</p>
34	Paint Spray Booth			Each	Used to provide an enclosure for paint spray operations.

## TO 1-1-700

Table 8-5. Accessories of Electronic Cleaning and Corrosion Control - Continued

Item No.	Nomenclature	Specification	National Stock No.	Unit of Issue	Intended Use
35	Brush, Cleaning	A-A-2074	7920-00-061-0037	Each	For removal of corrosion products and surface contamination from electronic equipment housings and enclosures.
36	Spot Touch-Up Spray Gun Draw Tube and Cap Assembly 6 oz. Cup		4949-00-270-1044 4949-00-222-2675 4949-00-272-7998	6 oz.	Priming and painting electronics housings and enclosures.
37	Air Brush, Artist Model 200		7520-00-939-6179		Touch-up paint and use with aerosol power unit.
38	Valve, Angle		4820-00-760-5592		Regulating air flow at spray gun.
39	Air Regulator Assembly with gauge, water and oil separator		4940-00-200-2096		Filtering air and regulating pressure for air drying and application of paint.
40	Sealant Gun, Hand Operated (6 oz.)		5120-00-952-3507	Each	Application of sealants.
41	Nozzle, Sealant Gun		5120-00-801-0949 5120-00-773-3791	1/32" orifice 1/8" orifice	For use with sealant gun.

Table 8-6. Recommended Cleaning Processes for Electronic Equipment

Type of Equipment	Aqueous Ultrasonics	Solvent Ultrasonics	Water Base Spray Booth	Abrasive Tool	Mini-Abrasive	Hand Clean
Housings, Enclosures, Racks, Chassis	X	X	X	X	X	X
Control Boxes	X	X(1)	X		X	X
Instruments					X(1)	X
Light Assemblies	X	X	X	X(1)	X	X
Waveguides	X	X	X	X(1)	X	X
Wire Harnesses			X		X	X
Servos/Synchros					X(1)	X
Antennas, blade	X	X	X		X	X
Antennas, dome	X(1)	X(1)	X	X(1)	X	X
Antennas, radar			X	X(1)	X	X
Antennas, ECM					X	X
Motors	X	X(1)	X	X(1)	X	X



**Table 8-6. Recommended Cleaning Processes for Electronic Equipment - Continued**

Type of Equipment	Aqueous Ultrasonics	Solvent Ultrasonics	Water Base Spray Booth	Abrasive Tool	Mini-Abrasive	Hand Clean
Generators	X	X(1)	X	X(1)	X	X
Batteries						X
Circuit Breaker Panels	X	X	X		X	X
Gyroscopes			X(1)		X(1)	X
Plugs and Connectors			X		X	X
High-density Connectors					X	X
Edge Connectors			X		X	X
Coaxial Connectors					X	X
Printed Circuit Boards			X			X
Note: (1) External Use Only						

### 8.6.2 Materials and Equipment.

8.6.2.1 Materials. Table 8-3 contains a list of approved materials for cleaning electronic equipment. Only materials, equipment, and techniques approved by the appropriate engineering authority shall be used on communications electronics equipment. Cleaning can be accomplished using the following methods:

8.6.2.1.1 Solvent cleaning - solvents are effective at removing grease and oil. They can be applied by wiping, brushing, soaking, or spraying.

8.6.2.1.2 Detergent/aqueous cleaning - detergent and water mixtures are used to remove dust, dirt, salt, grease, and oil. They can be applied by wiping, brushing, soaking, and spraying. Due to local environmental restrictions, aqueous cleaning may be preferred over solvent cleaning.

8.6.2.1.3 Distilled water - distilled water is used to dilute isopropyl alcohol or detergents. It is also used for rinsing after other cleaning materials have been used. Distilled water may be applied by wiping, brushing, soaking, rinsing, or spraying.

8.6.2.2 Equipment. Table 8-4 contains a list of approved equipment for cleaning electronics equipment. Only materials, equipment, and techniques approved by the appropriate engineering authority shall be used on communications electronics equipment. The following paragraphs describe various types of cleaning equipment and restrictions and guidelines for their use. They are intended to provide information and guidance, not specific operating instructions. Always refer to equipment-specific operating manuals for operation instructions.

8.6.2.3 Aqueous Ultrasonic Cleaner. The aqueous ultrasonic cleaner is used for the removal of dust, dirt, corrosion products, and salt spray deposits. This is achieved by ultrasonic scrubbing action in a water/detergent solution. The following guidelines shall be observed while operating the aqueous ultrasonic cleaner:

- a. Miniature and micro miniature PCBs are susceptible to damage caused by ultrasonic frequency and power level. Do not use an ultrasonic cleaner with these types of components without approval from appropriate authority.
- b. The aqueous ultrasonic cleaner shall be operated at a temperature less than 130 °F (54 °C) and a frequency of 20 kHz.
- c. Equipment may be “presoaked” in the detergent solution prior to cleaning in the aqueous ultrasonic cleaner.



MIL-D-16791, DETERGENT, NON-IONIC

22

- d. The aqueous ultrasonic cleaner shall be used with MIL-D-16791 detergent in a concentration of 1 ounce detergent to 1 gallon of water.
- e. Paper capacitors and paper-bound components disintegrate in MIL-D-16791 detergent and shall not be used in the aqueous ultrasonic cleaner.

## TO 1-1-700

f. Devices with permanently lubricated components (primarily bearings) can experience lubricant removal in the presence of MIL-D-16791 and shall not be cleaned in the aqueous ultrasonic cleaner. Equipment containing these components may be cleaned in the aqueous ultrasonic cleaner provided the lubricated components are securely sealed in a plastic bag.

g. Sealed components may trap water. After cleaning, all sealed components shall be opened to eliminate water traps and to facilitate drying.

**8.6.2.3.1 Solvent Ultrasonic Cleaner.** The solvent ultrasonic cleaner works similarly to the aqueous ultrasonic cleaner, except that it uses a solvent solution instead of a detergent solution for the bath. It is used to remove light to heavy oil, grease, and hydraulic fluid contamination by ultrasonic scrubbing in a solvent solution. The following guidelines shall be observed while operating the solvent ultrasonic cleaner:

- a. The solvent ultrasonic cleaner may be operated at any temperature up to the solvent's boiling point. The maximum operating frequency is 40 kHz. The solvent shall be specified by the manufacturer or maintenance authority.
- b. Neoprene materials (particularly coaxial connector gaskets) are vulnerable to damage from the solvent and shall not be cleaned in the solvent ultrasonic cleaner unless all vulnerable areas are sealed in a plastic bag.
- c. Devices with permanently lubricated components (primarily bearings) can experience lubricant removal in the presence of solvents and shall not be cleaned in the solvent ultrasonic cleaner. Equipment containing these components may be cleaned provided the lubricated components are securely sealed in a plastic bag.
- d. The solvent ultrasonic cleaner may be used as a solvent degreaser. When used as a degreaser, the solvent ultrasonic cleaner does not use the ultrasonic vibration function. Therefore, the cleaner may be used to rinse and dry PCBs provided that all other restrictions in this paragraph are followed.
- e. Sealed components may trap the solvent solution. After cleaning, all sealed components shall be opened to eliminate water traps and to facilitate drying.

### 8.6.2.3.2 Water Base Solvent Spray Booth.



MIL-D-16791, DETERGENT, NON-IONIC

22

The water base solvent spray booth removes dirt, dust, salt spray deposits, and light corrosion products. This is achieved by spraying the components with a detergent and water solution. The detergent solution is composed of 1 ounce of MIL-D-16791 for 1 gallon of water. In addition, it can spray water for rinsing purposes or compressed air for drying. The following guidelines shall be observed while operating the water base solvent spray booth:

- a. The water base solvent spray booth can be used as a precleaner to remove contaminants before the component is cleaned using another method.
- b. Devices with permanently lubricated components (primarily bearings) can experience lubricant removal in the presence of the detergent solution and shall not be cleaned in the water base solvent spray booth. Equipment containing these components may be cleaned provided the lubricated components are securely sealed in a plastic bag.
- c. Sealed components may trap the solvent solution. After cleaning, all sealed components shall be opened to eliminate water traps and to facilitate drying.

**8.6.2.3.3 Abrasive Tools.** Abrasive tools are commonly used for corrosion removal in a variety of circumstances. The following guidelines provide some instructions and restrictions regarding the use of abrasive tools on electronic equipment.

- a. Mono-basic sodium phosphate or glass beads used in abrasive tools can become trapped in miniature and micro miniature female edge connectors. When using a blast cabinet on components using these connectors is necessary, they shall be sealed with SAE-AMS-T-21595, Type I Pressure Sensitive Tape. The tape shall be removed and any adhesive residue removed immediately after cleaning.
- b. Delicate metal surfaces are extremely vulnerable to damage if abrasive tools are used improperly. Operators shall exercise extreme care when using abrasive tools on electronic equipment.
- c. Abrasive blast cabinets shall not be used on equipment that is sensitive to electrostatic discharge (ESD) in any circumstance.

**8.6.3 Cleaning Procedures/Selection Criteria.** Always select the mildest method of cleaning that will accomplish the task. Circuit components can be damaged if cleaned using the wrong support equipment. The method used shall be based on:

- a. Type and severity of the contamination or corrosion.
- b. Accessibility of the contamination or corrosion.
- c. Type of electronic equipment.

**8.6.3.1 Hazards of Cleaning.** Always use the gentlest materials and cleaning methods that will ensure complete cleaning or corrosion removal. In addition, always use the correct cleaning solutions mixed to the proper concentrations. Substitutions are not permitted. Using incorrect equipment, or solutions in high concentrations can result in damage to electronic components.

**8.6.3.1.1 Solvent entrapment** - solvents, detergents, or water may become trapped in crevices or cavities. This will interfere with additional cleaning or refinishing operations. In addition, it can prevent correct operation of the electronic equipment after the repair is complete.

**8.6.3.1.2 Over scrubbing** - prolonged abrasive scrubbing can cause delamination in printed circuit boards.

**8.6.3.1.3 Solvent attack** - certain solvents can soften conformal coatings, wire insulation, acrylics, and some circuit components. Do not substitute solvents in the cleaning process.

**8.6.3.2 When to Clean.** Immediate cleaning shall occur whenever any of the following conditions exist:

**8.6.3.2.1 Electronics have been exposed to adverse weather or salt-water spray.**

**8.6.3.2.2 Electronics have been exposed to fire-extinguishing agents.**

**8.6.3.2.3 Batteries have discharged electrolyte solution on or near electronic components.**

**8.6.3.2.4 Repair is necessary because of corrosion or component failure.**

**8.6.3.3 Precleaning Treatment.** Accomplish the following before starting a cleaning operation:

- a. Disconnect any external power supply from electronics.
- b. Remove batteries.

- c. Ensure that drain and vent holes are open.
- d. Remove covers, doors, etc.
- e. Disassemble or remove from enclosures if practical and necessary for the required cleaning.
- f. Verify the availability of authorized cleaning materials.
- g. Double-check the compatibility of cleaning materials before use.
- h. Mask vulnerable components to prevent the entrance of water, solvents, or detergents.

**8.6.3.4 Cleaning and Drying Restrictions.** Some circuit components are vulnerable to damage during the cleaning process. Usually, the potential for this damage can be minimized prior to cleaning. The biggest contributing factor to this damage is water or solvent trapped by a component. Vulnerable components and techniques to minimize their vulnerabilities are shown in Table 8-6. Procedures for sealing components are as follows:



TT-I-735, ALCOHOL, ISOPROPYL

65

- a. Seal small components with SAE-AMS-T-21595, Pressure Sensitive Tape. Ensure tape and tape residue are removed using Solvent Cleaning followed by wiping with TT-I-735 Isopropyl Alcohol prior to drying the equipment.
- b. Seal large components in plastic bags or seal with MIL-PRF-131 Water Vapor Proof Barrier Material. Place the bag or barrier material around the component and seal with SAE-AMS-T-21595 Pressure Sensitive Tape. Ensure tape, tape residue, and bag or barrier materials are removed using Solvent Cleaning followed by wiping with TT-I-735 Isopropyl Alcohol prior to drying the component.
- c. In some cases the component may be removed from the equipment without too much difficulty. When this is possible, the removed component shall be cleaned separately. This method is preferred for any component that can be easily removed.

Table 8-7. Cleaning and Drying Problems and Solutions

Component	Problem	Solution
APC connectors	Shock damage to conductors	Seal and hand clean only
Crystal detectors	Heat damage from oven	Dry at 130 °F (54 °C) Maximum
Delay lines	Trap solution in housing	Seal or remove
Fan motors	Trap solution in housing	Seal or remove
Gyroscopes	Trap solution in housing	Seal
Klystron cavity	Trap solution in sockets	Remove tube and seal sockets
Meters and gauges	Trap solution through open back	Seal
Paper capacitors	Disintegrate	Seal
Potentiometers	Trap solution	Seal
Printed circuit boards	Trap solution (when installed)	Remove and clean separately
Rotary switches	Trap solution in housing	Seal
Sliding RF attenuators	Trap solution in housing	Seal or remove
Sliding cam switches	Shock damage to cam	Remove or hand clean only
Synchros and Servos	Loss of bearing lubricant	Seal or remove
Transformers	Trap solution in housing	Seal
Tunable cavities	Trap solution in cavity	Seal or remove
Vacuum tubes	Shock damage	Remove
Variable microwave attenuators	Trap solution in housing	Seal or remove
Waveguide	Trap solution in housing	Seal or remove
Wire wrap connections	Shock damage	Hand clean only

8.6.3.5 Hand Cleaning Methods and Materials. Hand cleaning will be performed when components cannot tolerate other methods, when components are not easily removable from larger assemblies, or when other methods of cleaning are unavailable. Hand cleaning methods for electronics require the following materials:

- Cloth, CCC-C-46
- Cheesecloth, CCC-C-440
- Cotton tip applicator
- Acid Brush
- Toothbrush
- Brush
- Lint-free cloth, A-A-59323
- Cotton flannel, A-A-50129
- Plastic manual spray bottle

8.6.3.6 Removal of Fingerprints. Fats and oils deposited with fingerprints are highly corrosive. In addition, they can trap dust, corrosion product, or other contaminants. Fingerprints are to be removed using the following procedure:



TT-I-735, ALCOHOL, ISOPROPYL

65

- a. Apply a mixture of one part TT-I-735, Isopropyl Alcohol, and one part distilled water to affected areas with a CCC-C-46 Cleaning Cloth, acid brush, toothbrush or other brush as appropriate.
- b. Wipe or scrub affected area until contaminants have been removed.
- c. Remove residue by blotting or wiping with a CCC-C-46 Cleaning Cloth. Inspect affected areas for signs of residues and contaminants.
- d. Repeat steps a through c until all contaminants are removed.
- e. Discard contaminated cloths and solvents in approved disposal containers after cleaning operation to avoid contamination of other components.



TT-I-735, ALCOHOL, ISOPROPYL

65



Ensure that EPROM devices are protected from UV light and that ESD sensitive components are adequately protected.

**8.6.3.7 Removal of Solder Flux Residue.** Solder flux is used on all solder operations and it leaves behind a corrosive residue. Corrosion will occur if the flux residue is exposed to an electrolyte. Cleaning solder flux residue requires the use of solvents that do not damage the surrounding components. The presence of solder flux can be detected using ultraviolet light. Under UV light, solder flux residue appears as a fluorescent stain. Solder flux residue shall be removed with a solution of three parts TT-I-735, Isopropyl Alcohol, to one part distilled water.

**8.6.3.8 Removal of Silicone Lubricant.** Silicone residue can be removed from surfaces using the following procedures:



MIL-PRF-87937, CLEANING COMPOUND, AIRCRAFT 52



MIL-PRF-85570, CLEANING COMPOUND, AIRCRAFT 51

- a. Wipe surface with a CCC-C-46, Class 7 Cleaning Cloth, acid brush, disposable applicator, or pipe cleaner dampened with MIL-PRF-87937, Type IV, or MIL-PRF-85570, Type II, Cleaning Compound, until clean.
- b. Dry surface with a CCC-C-46, Class 7 Cleaning Cloth, disposable applicator, or pipe cleaner.

**8.6.3.9 Removal of Bacteria and Fungi.** Bacterial, mold, and fungal growth is facilitated by the presence of surface contaminants (such as dust, fingerprints, and corrosion product) and water. The best way to prevent or minimize the presence of these organisms is to maintain cleanliness and prevent moisture intrusion or high humidity. Fungus, mold, and bacteria shall be cleaned using the following procedure:

- a. Mask capacitors, relay contacts, switches, and tunable coils with SAE-AMS-T-21595, Type I, Pressure-Sensitive Tape.



TT-I-735, ALCOHOL, ISOPROPYL

65

- b. Apply a mixture of one part TT-I-735, Isopropyl Alcohol, and one part distilled water to affected areas with a CCC-C-46, Class 7 Cleaning Cloth, acid brush, toothbrush or other brush as appropriate.
- c. Wipe or scrub affected area until contaminants have been removed.
- d. Remove residue by blotting or wiping with a CCC-C-46, Class 7 Cleaning Cloth. Inspect affected areas for signs of residues and contaminants.
- e. Repeat steps a through c until all contaminants are removed.
- f. Discard contaminated cloths and solvents in approved disposal containers after cleaning operation to avoid contamination of other components.

**8.6.3.10 Removal of Dust, Dirt, Grease, and Oil.** Dust, dirt, grease, and oil can trap contaminants or moisture that facilitates the corrosion process. In addition, they can provide food for microorganisms that attack electronics. Dust, grease, dirt, and oil shall be removed using the following procedure:

## TO 1-1-700



MIL-PRF-87937, CLEANING COMPOUND, AIRCRAFT 52



MIL-PRF-85570, CLEANING COMPOUND, AIRCRAFT 51

- a. Apply a solution of one part MIL-PRF-87937, Type IV, or MIL-PRF-85570, Type II, Cleaning Compound to ten parts distilled water.
- b. Scrub affected areas of parts with a non-abrasive cleaning and polishing pad, a CCC-C-46, Class 7 Cleaning Cloth, CCC-C-440 Cheese-Cloth, acid swabbing brush, toothbrush, or cotton tipped applicator.
- c. Wipe area with a CCC-C-46, Class 7 Cleaning Cloth.
- d. Rinse area with clean, fresh water and dry with a CCC-C-46, Class 7 Cleaning Cloth.

**8.6.4 Drying Equipment and Procedures.** Drying time depends on the complexity of the component and the moisture content or humidity of the air where the drying is being performed. Complex parts require longer drying times. Humid environments also cause longer drying times. Before drying, make sure all covers and lids are opened or removed. In addition, remove any masking agents (tapes, plastic bags) that may be present.

**8.6.4.1 Air Drying.** Air drying is usually adequate for housings, covers, and some hardware. This method is not considered adequate for more complex equipment or components that may contain cavities or moisture traps.

**8.6.4.2 Hot Air Blower.** The following procedures shall be used when drying equipment using a hot air blower:

- a. Blow off excess water with dry air or dry nitrogen at not more than 10 PSI pressure. Deflect air off interior back and sides of enclosure to diffuse jet.
- b. Dry the equipment with an A-A-59435 Hot Air Gun, or a Raychem part No. HT-900 Hot Air Gun, as appropriate. Surfaces should not be heated with the hot air gun above 130 °F (54 °C) when drying equipment.

**8.6.4.3 Circulating Air Drying Oven.** The circulating air drying oven is used to dry small electrical and electronic components, such as unpressurized instruments, control boxes, PCBs, and similar devices. The circulating air drying oven

shall never be operated above 130 °F (54 °C) when drying electronic equipment or components. Damage may result from overheating of discrete electronic circuit components. Procedures for the operation of the circulating air drying oven are as follows:

- a. Blow off excess water with dry air or dry nitrogen at no more than 10 PSI pressure. Deflect air off interior back and sides of enclosure to diffuse jet.
- b. Set the temperature control at a maximum of 130 °F (54 °C).
- c. Place the component(s) in the oven and close the door. If a timer is available, set it for approximately 3 to 4 hours.
- d. Upon completion of the drying cycle, remove the component(s).

**8.6.4.4 Forced Air Drying Oven.** The forced air drying oven is the most efficient of the drying ovens. This unit can be used to dry all types and sizes of equipment and components. The procedures for the operation of the forced air drying oven are as follows:

- a. Blow off excess water with not more than 10 PSI dry air pressure or dry nitrogen. Deflect air off interior, back, and sides of enclosure to diffuse jet.
- b. Set the temperature control at a maximum of 130 °F (54 °C).
- c. Place the component(s) in the oven and close the door. If a timer is available, set it for approximately 1 to 2 hours. Opening and closing the oven door during drying will increase the drying time slightly but not appreciably. This is considered one of the advantages of the forced air drying oven over the circulating air type.
- d. Upon completion of the drying cycle, remove the component(s).

**8.6.4.5 Vented Drying Oven.** Vented drying oven procedures are as follows:

- a. Blow off excess water with not more than 10 PSI dry air pressure or dry nitrogen. Deflect air off interior, back, and sides of enclosure to diffuse jet.
- b. Dry the equipment at approximately 130 °F (54 °C) for 3 to 4 hours.

**8.6.4.6 Vacuum Drying Oven.** Vacuum oven drying procedures are as follows:



- a. Blow off excess water with not more than 10 PSI dry air pressure or dry nitrogen. Deflect air off interior, back, and sides of enclosure to diffuse jet.
- b. Dry the equipment at approximately 130 °F (54 °C) and 26 inches of mercury (Hg) for 1 to 2 hours.

**8.6.5 Preservatives.** Surfaces and components not normally conformal coated or painted need preservation. Cleanliness and elimination of moisture are keys to avoiding corrosion. Since it is impossible to guarantee a dry, moisture-free environment, preservation of equipment is essential. In today's electronic systems, miniaturization has resulted in micro miniature circuits no longer than a pencil eraser. The slightest amount of corrosion can cause an entire system to fail. Preservation has become an essential part of the repair and maintenance of electronic systems.

**8.6.5.1 When to Preserve.** Preservatives should always be used:

- After electronic cleaning or maintenance.
- Prior to shipment.
- On non-operating or idle equipment.
- On equipment awaiting parts.
- Whenever access for inspection is difficult or impossible without disassembly.
- Whenever protective coatings require additional protection in difficult-to-protect areas.
- After exposure to water, salt water, chemical agents, etc.
- Whenever existing corrosion protection has failed.

**8.6.5.2 What to Preserve.** Preservatives should be used only where their application and maintenance will not hamper circuit or component operation. Most preservatives form a nonconductive film that acts to insulate two mating surfaces. For example, preservative on a relay's mating contacts will degrade operation of the relay. Each piece of electronic equipment should be inspected. Areas requiring preservation should be noted and preserved on a scheduled basis.

**8.6.5.2.1** The following items may require preservation on a regular basis:

- Hinges and door latches.
- Electrical connectors and receptacles.

- Shock mounts, rigid mounts, and associated hardware.
- Any dissimilar metals not otherwise preserved.
- Antenna mounts, brackets, and hardware.
- Fasteners, screws, nuts, and bolts.
- Terminal boards, bus bars, and junction boxes.
- Lids on the interior or exterior of equipment that are susceptible to moisture.
- Solder joints not otherwise conformal coated.
- Unpainted brackets, racks, and shelving.
- Unpainted equipment covers, lids, and chassis.
- External and internal surfaces of coaxial connectors.
- External surfaces of cooling system joints.
- Grounding straps and wires.

**8.6.5.2.2** The following items shall not be preserved or come in contact with preservatives:

- Printed circuit boards that are conformal coated.
- Nonmetallic surfaces such as acrylic control box faceplates.
- Tunable capacitors and inductors.
- Internal surfaces of waveguides.
- Internal surfaces of tuned tanks.
- Relay and circuit breaker contacts.
- Fuses.

**8.6.5.3 Preservative Materials.** Preservatives may also act as water-displacing materials and lubricants. Table 8-8 contains a list of authorized preservative compounds for electronic equipment.

**8.6.6 Lubricants.** Lubrication of equipment performs several important functions. Not only does it prevent wear between moving parts, but it also provides a barrier against corrosive environments and chemically inhibits corrosion. Particular attention should be given to lubrication points, hinges, latches, lift rings, etc., for signs of lubricant breakdown (e.g. caking of grease, loss of oil or dry film lubricant, or evidence



## TO 1-1-700

of contamination). Maintenance personnel should refer to the applicable equipment system specific technical manual for lubrication requirements.

8.6.7 **Packaging.** Preventive maintenance techniques are rendered useless if these procedures are not followed. Materi-

als used to package, handle, or store C-E-M equipment must be compatible with the equipment and environment. Guidance for packaging electronic equipment can be found in Chapter 5 of this manual.

**Table 8-8. Preservative Compounds for Electronic Equipment**

Description	Characteristics	Application	Restriction
	 <p data-bbox="475 653 1154 705">MIL-PRF-81309, LUBRICANT, CORROSION PREVENTIVE COMPOUND</p>		46
	 <p data-bbox="475 842 1154 869">MIL-PRF-16173, COMPOUND, CORROSION PREVENTIVE</p>		37
Corrosion preventive compound, water-displacing, ultra-thin film, avionics grade, MIL-PRF-81309, Type II and III	General preservative for internal areas of electronic equipment; internal areas of electrical connectors, receptacles, and solder joints. Contains water-displacing properties.	Apply by spraying an even, thin film on the surface. Can be removed with cleaning solvent.	<p data-bbox="1024 1052 1414 1115">Not intended for use on exterior surfaces of electronic equipment.</p> <p data-bbox="1024 1136 1414 1289">Deposits a thin film which must be removed for proper function of contact points and other electromechanical devices where no slipping or wiping action is involved.</p> <p data-bbox="1024 1310 1430 1394">Do not use around oxygen, oxygen fittings, or oxygen regulators, since fire or explosion may result.</p>
Corrosion preventive compound, solvent cut-back, cold-application MIL-PRF-16173, Grade 4	General preservative for external surface exposed to elements and moisture, including: mounting racks, shelving, brackets, radar plumbing, shock mounts, rigid mounts, antenna hardware, general hardware, hinges, fasteners, ground straps; and exterior surfaces of electrical connectors, coaxial connectors, and receptacles.	Apply by brush or spraying an even thin film on the surface. Material presents a semi-transparent film. Can be removed with cleaning solvent.	<p data-bbox="1024 1419 1414 1541">Do not use on interior surfaces of electronic equipment, electrical connectors, coaxial connectors, or receptacles.</p> <p data-bbox="1024 1562 1398 1646">Do not use around oxygen, oxygen fittings, or oxygen regulators, since fire or explosion may result.</p> <p data-bbox="1024 1667 1414 1856">Must be applied over water-displacing corrosion preventive compound, MIL-PRF-81309, Type III, to accomplish a complete water-displacing and preservative on all areas exposed to elements and moisture.</p>

**Table 8-8. Preservative Compounds for Electronic Equipment - Continued**

Description	Characteristics	Application	Restriction
Corrosion preventive compound MIL-DTL-85054 (Non-ODS type)	Temporary repair of paint damage to exterior surfaces such as cracks and scratches preservative for non-moving metal parts not requiring a lubricated surface.	Apply by brush or spraying an even thin film to surface.	Do not use on interior surfaces of electronic equipment, electrical connectors, coaxial connectors, or receptacles.  Do not use around oxygen, oxygen fittings, or oxygen regulators, since fire or explosion may result.

## 8.7 CORROSION REMOVAL.

This paragraph outlines the materials, equipment, and techniques involved in corrosion control. It is important that personnel analyze the problem and select the correct corrosion removal and preservation materials. In addition, each case should be followed up where possible to see if the corrosion has been arrested. It is also extremely important that personnel correctly identify the material substrate of each component in question.

**8.7.1 Materials.** Whenever corrosion is detected, corrective action is required. If the corrosion is within repair limits as established by equipment system specific technical manuals, corrective action shall be taken. This action shall consist of cleaning, corrosion removal and treatment, and preservation as required. In all cases, the mildest effective methods shall be used for cleaning and corrosion removal. The following methods are approved for use on C-E-M equipment:

**8.7.1.1 Hand Rubbing/Abrasion.** The nature of some surfaces such as chrome, nickel, gold and silver plated contacts, cadmium and tin plated connectors and accessories, limit the use of highly abrasive methods. Tarnish and light corrosion can be removed from such surfaces by rubbing with

- an eraser;
- A-A-3077 and/or A-A-2074 Brushes;
- non-abrasive pad;
- A-A-58054, Abrasive Mat; or
- ANSI-B74.18, Abrasive Cloth.

**8.7.1.2 Portable Mini-Abrasive Unit.** The portable mini-abrasive unit is a hand-held miniature abrasive tool used to remove light corrosion products from small electronic components. For example, printed circuit board (PCB) edge connector pins, small structural components. This abrasive unit should not be used on plated surfaces.

**8.7.1.2.1 AWWA-B504, Monobasic Sodium Phosphate,** is the specified abrasive material for use in the mini-abrasive unit.

**8.7.1.2.2** The portable mini-abrasive unit shall be operated only in a blast cleaning cabinet. The monobasic sodium phosphate abrasive may contaminate other equipment and components if allowed to blow freely into the surrounding shop.

**8.7.1.3 Hand-Held Abrasive Tool.** This unit is used with a blast cleaning cabinet to remove corrosion products from electronic equipment structures and housings.

**8.7.1.3.1 SAE-AMS-2431/6 Glass Beads** are the required/allowed abrasive material for use in the hand-held abrasive tool.

**8.7.1.3.2** The hand-held abrasive tool shall be operated only in a blast cleaning cabinet. The glass beads may contaminate other equipment and components if allowed to blow freely into the surrounding shop.

**8.7.1.4 Chemical Paint Removers.** Paint removers specified in Chapter 2 of TO 1-1-8 shall be used to chemically remove paint and may be applied by brush. When used, care should be exercised in handling to avoid contact with the skin. The directions on the container and procedures in Chapter 2 of TO 1-1-8 shall be followed to ensure safe handling and best results. Whenever a chemical paint remover has been used, the surface should be thoroughly washed with fresh water and detergent prior to any paint application.

## 8.8 SURFACE TREATMENT.

Proper surface treatment is essential to preventing corrosion from returning after it has been removed.

**8.8.1 Chemical Conversion Coatings.** Chemical conversion coatings are aqueous acid solutions of active inorganic compounds which combine with aluminum or magnesium surfaces to form a corrosion resistant film. In addition, they also improve the adhesion of paints or primers. Guidance regarding the use of chemical conversion coatings can be found in Chapter 7 of this manual.

## TO 1-1-700

**8.8.2 Protective Coatings.** Protective coatings are susceptible to damage by handling, accidental scratching, and corrosion. The functions of boxes, chassis, housings, and frames are to enclose, protect and secure the vital internal components of any electronic assembly. Therefore, it is important that this structural integrity be maintained. Painted surfaces will withstand a normal amount of abrasion from handling and hand tools. However, chipped, scrapped, scratched, and scuffed surfaces of protective paint will cause the base metal of the structure to become corrosion prone. The electronic technician shall pay particular attention to the mishandling of hand tools and avionic equipment. A few minutes of extra time spent in the careful use of tools will save hours of paint touchup and corrosion removal work. Any painting operation involves three basic steps: surface preparation; application of primer and/or undercoat; and application of one or more finish/top-coats. Guidance regarding the application of protective coatings can be found in Chapter 7 of this manual.

**8.8.3 Encapsulates.** Encapsulates are materials used to cover a component or assembly in a continuous organic resin. Encapsulates provide electrical insulation, resistance to corrosion, moisture, fungus, and mechanically support the components. In military electronic equipment, encapsulates are classified as follows:

**8.8.3.1 Potting Compounds.** Potting compounds are used to seal electrical connectors, plugs, and receptacles. Potting compounds are used for their moisture-proof and reinforcement properties. They are used on electrical connectors to protect against fatigue failures caused by vibration and lateral pressure at the point of wire contact with the pin. Potting compounds also protect electrical connectors from corrosion, contamination, and arcing by the exclusion of moisture, stray particles, and liquids (hydraulic fluid, fuel, and oil).

**8.8.3.1.1 Materials.** The following materials shall be used for "potting" electrical connectors:



MIL-PRF-8516, TYPE II, SEALING COMPOUND,  
POLYSULFIDE RUBBER 49

**8.8.3.1.1.1 MIL-PRF-8516 Sealing Compound, Synthetic Rubber, Accelerated,** is a two-part synthetic rubber compound. It consists of a base and an accelerator (curing agent) packaged together. It is used for sealing low voltage electrical connectors, wiring, and other electrical apparatus, where temperature does not exceed 200 °F (93 °C).



MIL-A-46146, ADHESIVE/SEALANT, SILICONE RTV,  
NON-CORROSIVE, GROUP I/II/III, TYPE I OR GROUP I,  
TYPE II 19

**8.8.3.1.1.2 MIL-A-46146 RTV** is used for sealing electrical connectors electronic components where a more flowable, one-part material is required. This material is also used as a conventional sealant.



MIL-PRF-81733, SEALING AND COATING COMPOUND,  
CORROSION INHIBITIVE 48

**8.8.3.1.1.3 MIL-PRF-81733, Sealing and Coating Compound,** is used to prevent entry of corrosive environments. This material is also used as a conventional sealant.



MIL-M-24041, SEALING COMPOUND 33

**8.8.3.1.1.4 MIL-M-24041 Sealing Compound,** is a two-component polyether polyurethane system consisting of a pre-polymer and a curing agent before mixing. These compounds are flexible cold-flow and cold-resistant materials with excellent electrical properties and are intended for use in a seawater environment. This compound will adhere to metal, rubber, or polyvinylchloride, and may be used for the sealing and reinforcement of electrical connectors, wiring and other electrical apparatus. This compound is used to seal connectors located in areas where the temperature range is -80 °F to +300 °F.

**8.8.3.1.2 Precautions.** When using potting compounds, the following precautions shall be observed:

**8.8.3.1.2.1** Apply potting compounds only to clean surfaces.

**8.8.3.1.2.2** Follow instructions carefully when mixing the base compound and accelerator. Substitution, partial mixing, or incorrect proportions of base compound and accelerator may produce a sealant with inferior properties.

**8.8.3.1.2.3** Do not mix base compounds and accelerator components of different batch numbers because substandard electrical properties may result.

8.8.3.1.2.4 Potting compounds may contain small quantities of flammable solvents and/or release by-products on curing. Adequate ventilation and fire precautions are required during mixing, curing, and/or storage of potting compounds.

8.8.3.1.2.5 Potting compounds that have exceeded normal shelf life are not to be used.

8.8.3.1.2.6 Avoid the use of masking tape and fiberboard molds. If potting molds are not furnished with connector or are not available, a plastic sleeve should be constructed. This will aid in forming the potting compound around the connector shell.

8.8.3.1.2.7 Allow potting compounds to cure until firm prior to installing connectors or components in equipment.

8.8.3.1.2.8 Frozen, premixed potting compounds should be used as soon as possible after the removal from the deep freeze or a significant (approximately 50%) reduction in work life can be experienced.

8.8.3.1.2.9 Remove reverted potting compounds as soon as possible.

8.8.3.1.3 Reverted Potting Compounds. Depending on the environment, potting compounds, such as Pro-Seal 777 (green) and EC-2273 (black), are known to revert to a liquid after a year or two. Compounds that revert exhibit a sticky, oozing consistency that flows out of the connector. In some cases, the reverted potting compounds flow around through the pins and receptacles, insulating the connections where continuity is required.

8.8.3.2 Conformal Coatings. Conformal coatings are used to encapsulate PCBs and modules. Guidance for using conformal coatings can be found in TO 00-25-234 or in equipment system specific technical manuals.

8.8.3.3 Fungus-Proof Coatings. Fungus proof coatings, usually varnish, used to encapsulate certain electronic circuit components in a thin protective film that is impervious to fungus attack. Usually used in older macro electronic and electrical components. Fungus-proof coatings should not be applied indiscriminately to all electronic components. Treat only those components that have been treated or are specified in the applicable equipment system specific technical manuals. Fungus-proof coatings can, in some instances, be detrimental to the function/maintenance of equipment. For example, it deteriorates wire insulation and its removal is labor intensive. The entire surface shall be retreated only when touch-up procedures will not provide protection to the item. Considering the difficulties of applying a fungus-proof coating, it is important to recognize that if the coating is not properly maintained; many hours of additional repair time will be required.



ASTM D 3955 (MIL-V-173), VARNISH, ELECTRICAL INSULATING

12



A-A-3007, THINNER, PHENOLFORMALDEHYDE AND MEDIUM OIL AND STYRENATED ALKYD PAINTS AND VARNISHES

1

The authorized fungus-proof coating is Varnish, ASTM D 3955. If it is found necessary, the varnish may be thinned with A-A-3007 Thinner.

8.8.3.3.1 Items to be Protected Against Fungus-Proof Varnish. Varnish shall not be applied to any surface where it interferes with the operation/performance of the equipment. Such surfaces shall be protected against varnish application by masking with Pressure Sensitive Tape, SAE-AMS-T-22085, Type II. The following items shall be protected from fungus-proof varnish:

8.8.3.3.1.1 Components and materials:

- Cable, wire, braids, and jackets that are flexed during operation of the equipment.
- Cables where treatment would reduce the insulation resistance below, or increase the loss factor above, the acceptable values. These values are specified in the applicable service directives.
- Variable capacitors (air, ceramic, or mica).
- High wattage and wire-wound resistors.
- Ceramic insulators that are subject to an operating voltage of over 600 volts and in danger of flashover.
- Painted, lacquered, or varnished surfaces, unless otherwise specified.
- Rotating parts such as dynamotors, generators, motors, etc. However, electronic components associated with these parts shall be treated in accordance with procedures outlined in this manual.
- Waveguides (working surfaces).
- Electron Tubes.

## TO 1-1-700

- Tube clamps.
- Miniature tube shields.
- Plug-in relays.
- Pressure-contact grounds.
- Coaxial test points or receptacles.
- Windows, lenses, etc.
- Transparent plastic parts.
- Plastic materials such as polyethylene, polystyrene, polyamide, acrylic, silicone, epoxy (other than printed wiring boards) melamine-fiber-glass, fluorocarbon, vinyl, and alkyd.
- Materials used for their specific arc-resistant properties and classified as such.

8.8.3.3.1.2 Electrical contacts, contact portions, or mating surfaces of binding posts. Also connectors, fuses, jacks, keys, plug, and relay sockets (including tube sockets, switches and test points).

8.8.3.3.1.3 Mechanical parts.

8.8.3.3.1.4 Surfaces which rub together for electrical or magnetic contact. For example, bearings, contact fingers, potentiometers, shafts, shields, and variable auto-transformers.

8.8.3.3.1.5 Surfaces whose operational temperature exceed 266 °F (130 °C) or whose operating temperatures will cause carbonization or smoking.

8.8.3.3.2 Application. The varnish coating shall be applied by spraying, brushing, dipping, or any combination. The dried film shall have a clear, smooth finish (free from bubbles, wrinkles, filaments, or spray dust). The running, lumping, or gathering of the film into drops shall be avoided. Where practical, the dry film thickness shall be at least 2.0 mils (0.002 inch).

8.8.3.3.2.1 Spraying. For larger equipment, a pressure pot spray gun with a tip regulated to give a wet spray is recommended. For small compact equipment, a pencil spray tip, regulated to give a narrow wet spray, is recommended. The varnish shall be applied in a wet coat over all parts to prevent the formation of fuzz or filaments. A dry spray which forms spray dust shall not be used. The equipment or individual assembly shall be sprayed from as many angles as necessary to assure complete coverage with a wet coat. If more than one coat of varnish is applied, sufficient drying time should be allowed between each coat.

8.8.3.3.2.2 Brushing. All parts which cannot be reached by spray shall be coated as completely as practicable with a brush. A brush may also be used to cover small areas not covered during the spraying process. On those components requiring extensive masking, brush application of the coating material may prove more efficient than spray application.

8.8.3.3.2.3 Dipping. Subassemblies or components may be coated by dipping, provided all requirements are met.

8.8.3.3.3 Curing of Varnish. Equipment coated with varnish shall be dried by heating to 130 °F (54 °C). Heating shall be gradual to prevent shrinking, cracking, warping, or other deterioration of the parts or materials. The drying temperature should be maintained for at least 1/2 hour but not longer than 3 hours. Drying may be done in a vented oven, vacuum oven, or with an A-A-59435 Hot Air Gun (shop use only).

8.8.3.3.4 Precautions. The following equipment requires special precautions for the application of varnish:

8.8.3.3.4.1 Radio Receivers and Transmitters. The application of varnish will cause changes in some of the circuit constants. These changes may be discernible only by electrical tests and measurements. A change in alignment may be noted immediately after application of the varnish. As the varnish dries and ages, further changes in circuit constants may take place. The greatest change ordinarily will occur within 72 hours after treatment. The set should be completely realigned at the end of that period.

8.8.3.3.4.2 Coil Shields. When coil shields are removed and replaced, they can be damaged and alter the tuning adjustments. If the damage is great, proper alignment is impossible. Extreme care must be exercised in removing and replacing coil shields.

8.8.3.3.4.3 Trimmer Capacitors. Avoid spraying or brushing varnish on the plates of trimmer capacitors. To minimize damage, all trimmer capacitors should be completely covered during coating. If these capacitors fail to operate satisfactorily after treatment, make a thorough inspection for deposits of varnish.

8.8.3.3.4.4 Tuning Slugs. Extreme care must be taken in removing and replacing tuning slugs. If varnish is accidentally applied to a slug, remove it before replacing the slug.

8.8.3.3.4.5 Discriminator Circuits. Careful adjustment of discriminator circuits after treatment is essential, especially in the case of frequency-modulated receivers. Discriminator circuits are more susceptible to change in circuit constants caused by varnish than other part.



8.8.3.3.4.6 Tuned Circuits. Be especially careful during masking to ensure that wires associated with tuned circuits are not moved. Movement of such wires may cause changes in circuit values.

8.8.3.3.4.7 Relays. Deposits of varnish on the armature, pivots, or similar components will cause the relays to bind. The whole relay should be carefully masked until after spraying has been completed. A brush should be used to coat the coils and leads after the masking has been removed. Relays with palladium-tipped contacts should be removed before application of varnish.

8.8.3.3.4.8 Meters. Since meters are easily damaged by the varnish spray treatment, all meters must be checked for accuracy before treatment. Some meters may be affected by heat. In other instances, meter magnets may be affected by magnetic fields that exist around drying equipment. Refer to the applicable service directives for instructions on varnish spray treatment of meters. If guidance is not available, do not apply varnish.

8.8.4 Sealants. Sealants are another type of protective film used in C-E-M equipment. Sealants are either liquids or pastes which solidify after application. They form a flexible seal, preventing moisture intrusion at mechanical joints, spot-welds, and threaded closures. In addition, sealants prevent entry of corrosive environments to faying surfaces, fastener areas, exposed landing gears switches, and other metal-encased avionic equipment. They function principally as waterproof barriers. It is therefore very important that damaged sealants be repaired as soon as possible. Detailed information on sealants can be found in Chapter 12 of this manual.

8.8.4.1 Suitable for Electronics. The following sealants are approved for use on electronic equipment:



AMS-S-83318, SEALING COMPOUND, LOW TEMPERATURE CURING 10

8.8.4.1.1 AMS-S-83318 Sealing Compound, Low Temperature Curing, is a quick cure sealant used for sealing gaps and depressions on areas during extreme cold activities. Apply with an A-A-3077, Style T Typewriter Brush.



MIL-A-46146, ADHESIVE/SEALANT, SILICONE RTV, NON-CORROSIVE, GROUP I/II/III, TYPE I OR GROUP I, TYPE II 19

8.8.4.1.2 MIL-A-46146 Adhesive-Sealant, Silicone, RTV, Non-Corrosive is used for sealing avionic equipment in areas where temperatures are between 250 °F (121 °C) to 350 °F (177 °C). MIL-A-46146 RTV Coating, Flowable, Brush Application is used for encapsulating and sealing of electrical and electronic components. This material has good resistance for oxidation, weathering, and water.



MIL-PRF-81733, SEALING AND COATING COMPOUND, CORROSION INHIBITIVE 48

8.8.4.1.3 MIL-PRF-81733 Sealing and Coating Compound can be used to seal gaps, seams, and faying surfaces with temperatures up to 250 °F (121 °C). This material is applied by brush.

8.8.4.2 Unsuitable for Electronics (Containing Acetic Acids). Any RTV silicone sealant that gives off acetic acid during its cure cycle is corrosive and shall not be used on electronic components.

## 8.9 HANDLING OF SPECIFIC EQUIPMENT/COMPONENTS.

When corrosion is detected, the methods used for removal and repair shall be based primarily on the material substrate. However, some components have special requirements based on their function or operational environment.

8.9.1 Bonding/Grounding. Electrical bonding provides a low resistance electrical path between two or more conductive units or components. Grounding is a form of bonding that utilizes the primary structure as a portion (return path) of the electrical circuit.

### 8.9.1.1 Cleaning and Corrosion Removal.

- Remove all dirt, oil, and grease from a circular area slightly larger than the connection. This area should correspond to about 1-1/2 times the diameter of the connection. Use an A-A-59323, Type II Cleaning Cloth, dampened with Cleaning Solvent.
- If more vigorous soil removal is required, scrub with an A-A-3077 Typewriter Brush until all contaminants are removed.
- Wipe with a dry A-A-59323 Type II Cleaning Cloth.
- Remove paint, anodize, or conversion coating film and surface corrosion from the planned attachment area with a A-A-58054, Type I, Grade B Abrasive Mat. For corrosion beyond the surface corrosion stage, refer to TO 1-1-691.

## TO 1-1-700



## TT-I-735, ALCOHOL, ISOPROPYL

65

- e. Wipe clean with a A-A-59323, Type II Cleaning Cloth, dampened with TT-I-735 Isopropyl Alcohol.
- f. Allow to air dry.
- g. For magnesium or aluminum alloys, treat the bare metal surface with chemical conversion coating material as described in Chapter 7 of this manual.



## TT-I-735, ALCOHOL, ISOPROPYL

65

- h. Clean bonding cable with an A-A-59323, Type II Cleaning Cloth dampened with TT-I-735 Isopropyl Alcohol.
- i. If necessary, use an A-A-3077 Typewriter Brush to scrub the strap until all corrosion products and contaminants are dislodged.
- j. Wipe clean with the solvent-dampened cloth and allow to air dry.

8.9.1.2 Preservation. Preservation methods should be used following corrosion cleaning and removal.

8.9.1.3 Application. Apply MIL-PRF-81309 Water-Displacing Corrosion Preventive Compound, according to Table 8-7. The following procedures apply for bonding/grounding connections that are not environmentally protected continually.



## MIL-PRF-81309, LUBRICANT, CORROSION PREVENTIVE COMPOUND

46



## MIL-PRF-16173, COMPOUND, CORROSION PREVENTIVE

37

- a. For bonding/grounding connections that require fairly frequent disassembly, preserve the connection area by applying MIL-PRF-81309, Type III Corrosion Preven-

tive Compound, followed by a coating of MIL-PRF-16173, Grade 4 Corrosion Preventive Compound.



## MIL-PRF-8516, TYPE II, SEALING COMPOUND, POLYSULFIDE RUBBER

49

- b. For connections that seldom require disassembly, preserve with the more permanent and abrasion-resistant MIL-PRF-8516, Type II Sealing Compound, applied with a spatula.

8.9.2 EMI Shielding. Electromagnetic energy that is generated/absorbed by communications electronics can interfere with systems causing malfunctions. This radiation, known as electromagnetic interference (EMI), is produced by radar antennas, electric motors, inadequately shielded circuits, etc. Some examples of EMI-related system malfunctions are microprocessor bit errors, computer memory loss, false indicators (i.e., alarms, lights, readouts), and power loss. In order to minimize EMI-induced failures, C-E-M housings must absorb and reflect incident electromagnetic energy. Usually the shielding system consists of a conductive gasket sandwiched between an aluminum alloy housing and an aluminum alloy lid. This gasket provides sufficient electrical conductivity across the enclosure/gasket/lid junction per military grounding/EMI shielding requirements. It also prevents fluid intrusion into the components.

8.9.2.1 Effects of Corrosion on EMI Shielding. Corrosion can degrade the electrical and mechanical properties of a joint. The exposure of EMI gaskets to various environmental conditions can significantly reduce its shielding effectiveness and service life. Under field service conditions, communications electronics experience corrosion between metal surfaces such as joints. In these environments, exclusion of electrolyte from the joint is essential to maintaining an EMI seal. Use of nonconductive environmental seals (gaskets, sealants, and coatings) must be used to exclude moisture from the joint. Corrosion-induced changes in bulk resistivity of the EMI gasket may contribute to degradation of the EMI seal.

8.9.2.2 Addressing Corrosion. Corrosion issues need to be addressed to prevent the interference of the electrical and mechanical properties of an EMI shielding joint. This can be accomplished by performing an inspection followed by a corrosion treatment.

8.9.2.2.1 Inspection. EMI gaskets should be periodically checked to ensure they are continuing to provide their intended functions. Inspection intervals should balance the need for proper operation and the environment, with the

destructiveness caused by surface wear of gaskets with disassembly/reassembly. Gaskets may deteriorate via attack by operational chemicals, corrosion, and wear. Therefore inspection should include the following:

- a. Check for corrosion products, pitting of the aluminum alloy surface, or bulges in the sealant due to corrosion beneath the gaskets.
- b. Check the bonding of the gasket to the structure to prevent moisture intrusion.
- c. Check for loss of electrical conductivity of the gasket or its electrical bond to the equipment.
- d. Check for wear and swelling of the gasket.
- e. Check for compression set of the seal.
- f. Check maintenance procedures are being followed (e.g. avoid solvents which can wash away conductive particles).
- g. Check for excessive bending and/or pulling of electrical cables and shields.

**8.9.2.2.2 Treatment.** Corrective maintenance of EMI gaskets depends on the type of gasket involved, size of the damaged area, and degree/type of corrosion. EMI gaskets are usually of either metal or conductive elastomer construction. Finger stock, mesh, and spiral ribbon are examples of metal gaskets. Conductive elastomers consist of dispersions of conductive particles (spheres, irregular shapes, fibers) in elastomer matrices. Oriented wire gaskets have characteristics of both categories. Since each type of EMI gasket has its own specificities, each will require special corrosion treatment/repair. The following "generic" gasket repair procedure is outlined below for general guidance. Maintenance personnel should refer to the applicable equipment system specific technical manuals for more specific repair information.

- a. When corrosion is observed, disassemble only the affected area and remove the corrosion using the mildest available method.



TT-I-735, ALCOHOL, ISOPROPYL

65



MIL-PRF-81309, LUBRICANT, CORROSION PREVENTIVE COMPOUND

46

- b. Carefully clean the area with TT-I-735 Isopropyl Alcohol. If replacement seals are available, install them in accordance with aircraft maintenance instructions or bulletins. If replacement seals are not available or do not exist, spray the contacting surfaces with a light coating of MIL-PRF-81309, Type III and then reassemble.
- c. Inspect repairs and areas known to be chronic problems often.

**8.9.3 ESD Sensitive Components.** Very Large Scale Integration (VLSI) digital components are steadily increasing in functional power, speed, and system applications in military avionics. By making the VLSI devices small, less voltage is needed to operate circuitry and the noise immunity decreases. Many of these devices are highly susceptible to damage from the discharge of static electricity. Electrostatic discharge (ESD) affects many components such as transistors, resistors, integrated circuits and other types of semiconductor devices. A spark discharge resulting from the accumulation of electrostatic charges may not immediately destroy a device or cause it to become nonfunctional. The device can be permanently damaged, yet perform its intended function. Additional exposure to spark discharges or continued use of the device can further damage the item until failure occurs. This is known as a latent failure and can seriously affect a system's reliability. It is essential that everyone involved in the repair handling, transporting, and storing of electrostatic discharge sensitive (ESDS) items be concerned about ESD. All ESDS items should be packaged, shipped, and stored in ESD protective materials. Further information on the Air Force ESD program is contained in TO 00-25-234.

**8.9.3.1 Effects of Corrosion.** Corrosion can degrade the electrical and mechanical properties of ESD protection systems. The exposure of ESD devices/ESD protection systems to various environmental conditions can significantly increase their susceptibility to damage from the discharge of static electricity. Under field service conditions, military electronics experience corrosion between metal surfaces such as electrical bonding/grounding connections. This problem is two-fold. First, corrosion between metal surfaces in electronics creates structural weaknesses that undermine its effectiveness to shield ESDS components from induced potentials. Second, the corrosive process creates nonconductive products that decrease the paths of conduction of static charge away from the device or assembly.

**8.9.3.2 Recommended Practices for Handling ESD Sensitive Components.** ESD precautions are not limited to manufacturing or component repair personnel only. Anyone handling, processing, or using ESD devices must take precautionary steps. It would be futile for component repair personnel to take full precautions only to turn the repaired item over to technicians who ignore all precautions and inad-

**TO 1-1-700**

vertently destroy the module. Maintenance personnel should refer to MIL-HDBK-773, MIL-HDBK-263, and MIL-STD-1686 for more detailed descriptions of ESD control measures.

8.9.3.2.1 Packaging for electrostatic discharge protection requires the use of one or more of the following materials:

- MIL-PRF-81705, Type II Barrier Material, Transparent, Waterproof, Electrostatic Protective, Static Dissipative.
- Cushioning material, flexible, cellular
- Cushioning material, plastic open cell.
- PPP-C-1797, Cushioning Material, Resilient, Low Density, Unicellular, Polypropylene Foam.

8.9.3.2.2 ESD items may be further protected in reusable A-A-59736, Type II, style D ESD Fast Pack Containers or shielded in a bag or pouch conforming to MIL-PRF-81705, Type I Barrier Material, Water Vapor-Proof, Grease-Proof, Electrostatic and Electromagnetic Protective (Opaque).

8.9.3.2.3 Protection will be provided to prevent physical damage and to maintain leads and terminals in an as-when-manufactured condition during handling and transportation.

8.9.3.2.4 Packaging of ESD items shall be in accordance with MIL-E-17555 for electrostatic protection. Marking shall be in accordance with MIL-STD-129.

8.9.3.3 Addressing Corrosion. ESD damage to communications electronics devices can be caused by voltage or current depending on the item's composition and construction. This damage can be caused by direct contact or by the electrostatic field associated with other charged items. It is important to note that some modern military circuits are sensitive to voltages as low as 25 volts. The threshold of sensitivity or voltage level required for a human being to feel a static discharge is approximately 3500 volts. Therefore, ESD devices can be damaged by maintenance personnel without their knowledge. ESD control measures must be employed to minimize the impact of ESD damage on communications electronics parts, assemblies, and equipment.

8.9.3.3.1 Preventive Maintenance and Control. ESD devices must be protected from static fields and/or static discharge when being transported, handled, or stored. The following preventive measures will help provide this protection:

- a. Handle ESD devices only at protected work stations. These sites eliminate all sources of ESD with good grounding techniques by electrically bonding all the sur-

faces, tools, and furnishings together. A protective stool should also be used and any support equipment (soldering irons, test fixtures, test equipment, lights, etc.) must be grounded.

- b. ESD devices should be covered or packaged in ESD-protective packaging when not being handled.
- c. Conductive carriers protect static sensitive devices by shielding them from static. These carriers are used to transport, store, and ship static sensitive devices and should be placed on a conductive table top. This allows safe removal of their contents. Example of conductive carriers are conductive trays, boxes, and containers.
- d. Shunting mechanisms short circuit all the leads of a device. This enables the entire device to be at the same electrical potential and prevents ESD. Shunting mechanisms for discrete components include shorting clips, rings, and conductive foam. Conductive shunt bars are a type of shunting mechanism for printed circuit boards (PCBs).
- e. Nonconductive objects that can generate and hold different static potentials on different areas on their surface are poor conductors and cannot be grounded. Static neutralizing equipment should be used to eliminate static charges on nonconductive objects. Use of an ionized air blower will neutralize static charge by continuously blowing a cloud of ionized air over the surface.
- f. Personnel should not wear synthetic fiber clothes. Cotton clothes with short sleeves or a cotton smock over clothing are recommended.
- g. Work areas shall be clear of static hazards such as ordinary plastics, coffee cups, and candy wrappers.
- h. Personnel shall only use uninsulated hand tools when working with electrostatic sensitive devices. Don't use plastic-coated tweezers, plastic lead-forming tools, or plastic solder suckers. Also, personnel shall use only natural bristle brushes.

8.9.3.3.2 ESD Protective System Repair and Treatment. Corrective maintenance of ESD protection systems depends on the type of protection system involved, size of the damaged area, and degree/type of corrosion. Control, treatment, and repair measures must be employed to minimize the impact of corrosion on ESD protection systems. Maintenance personnel should refer to Chapter 7 and paragraph 8.6 of this manual and the applicable equipment system specific technical manuals for specific repair procedures.

## CHAPTER 9 INSPECTION

### 9.1 PURPOSE.

Frequent corrosion inspections are essential for an effective overall corrosion control program. Early detection, identification, and treatment minimizes the costs resulting from corrosion damage. Without regular systemic inspections, corrosion will seriously damage Communications, Electronics, and Meteorology (C-E-M) equipment and its protective shelters and radomes. This chapter describes the basic visual and Non-Destructive Inspection (NDI) procedures for detecting corrosion as well as some of the signs of corrosion damage.

**9.1.1 Responsibility.** Corrosion detection is everyone's responsibility. Since corrosion can occur almost anywhere on C-E-M equipment, shelters, and radomes, all maintenance personnel must be able to identify and report corrosion problems. Personnel performing scheduled inspections shall be qualified in corrosion detection and shall have attended appropriate corrosion prevention and control courses established by AETC and the MAJCOM, and required by AFI 21-105.

**9.1.2 Frequency of Inspection.** The frequency and extent of inspections are established by the C-E-M and Shelter/Radome System Program Director (SPD) and/or System Program Manager (SPM). However, during scheduled or unscheduled maintenance actions on this equipment and their components, the area involved as well as those within 36 inches (18 inches on each side) of the repair or treatment area shall be visually inspected for corrosion. Additionally, inspections of areas particularly prone to corrosion, such as shelter skids and undercarriage, door hinges, lift rings, magnesium parts, etc. may be necessary. Corrosion prone areas are discussed in Chapter 10 of this manual.

**9.1.3 General Inspections.** A general inspection of shelters, radomes, and C-E-M equipment is performed as follows:

- a. Clean area thoroughly per instructions in Chapter 8, Cleaning Procedures, of this manual.



Prior to removing any access panel coated with epoxy primer, either with or without a polyurethane topcoat, score the coating system at the edges of the cover/panel with a sharp plastic tool to prevent fraying or peeling of the paint finish system when the panel is removed for the first time after the finish system is applied.

- b. If corrosion is suspected, examine the area with a 10X magnifying glass and flashlight. Pay particular attention to edges of skin panels, rivet heads, and other corrosion prone areas. If blisters, bubbles, or other coating irregularities are present, attempt to dislodge the paint scraping with a sharp plastic tool. If paint does not dislodge easily, the irregularity is probably a sag or run which is confined to the paint film itself and no further action is necessary. When corrosion is suspected but no irregularities are present, clean and dry the area per procedures in Chapter 8 of this manual, and apply a Strip 3M Co. part No. 250 (preferred) or A-A-883, Type II flat-back masking tape over the suspect area leaving a two inch length free at one end. Hand rub the tape for several strokes in order to assure good adhesion. Grip the free end of the tape and remove the tape with an abrupt lifting motion. Where paint is removed, inspect and determine the extent/degree of corrosion as described in Chapter 9 of this manual.
- c. Remove corrosion, clean, and treat the surface per procedures in Chapters 7 and 11 of this manual, and touch-up the paint per procedures in TO 1-1-8.

**9.1.4 Detailed Inspections.** A detailed inspection of C-E-M equipment, Shelters, and Radomes shall be performed if the corrosion damage found during a general inspection is suspected to be extensive or severe, and/or as specified in appropriate system specific CEM/Shelter/Radome equipment maintenance manuals. See Chapter 10 of this manual for information on common corrosion prone areas.

### 9.2 INSPECTION METHODS.

The most likely methods of inspection encountered on C-E-M equipment are discussed in this paragraph.

**9.2.1 Visual Inspection.** Visual inspection is the most widely used method for the detection and evaluation of corrosion. It is very effective for detecting most types of corrosion if done carefully with a knowledge of where and for what to look. Read Chapter 3 before performing a corrosion inspection, paying particular attention to Table 3-1. The following tools can be used to find and evaluate the extent of corrosion damage: flashlight; 10X magnifying glass; plastic or non-metallic scraper; and depth gage, pin micrometer type.

**9.2.1.1** First, conduct an overall general inspection to note obvious corrosion, corrosion products, or coating defects. Further examine damaged or deteriorated areas using a 10X magnifier and flashlight. Edges of panels, rivet heads, razor edge



**TO 1-1-700**

doors, and other corrosion-prone areas should also be carefully examined. When corrosion occurs beneath a paint system, the surface of the paint often appears blistered or distorted. Further inspect areas showing corrosion stains, coating blistering, or other coating irregularities to determine the extent of corrosion. If blisters or other coating irregularities are present, attempt to dislodge the paint by scraping with a sharp plastic tool. If the paint is not easily dislodged and corrosion is not suspected, the irregularity is probably confined to the paint film itself, and no further action should be taken. Where paint is removed, inspect the area and determine the degree of corrosion. Corrosion removal and surface preparation should be carried out as described in Chapter 11 of this manual. Repaint the surfaces with one of the coating systems listed in Chapter 7 of this manual per procedures outlined in TO 1-1-8.

**9.2.1.2 Evidence of Corrosion.** Aluminum corrosion products are white, gray, or black and may appear as a paste when wet or as either a hard, adherent film or easily crumbled deposits when dry. Steel corrosion products (rust) are red, brown, or black deposits either in the form of a powder or when severe as flakes that spall off easily. Stainless steels do not produce significant amounts of visible corrosion products on their surfaces, but they exhibit small amounts of rust and/or discolored areas and sometimes cracking. Copper corrosion products (patina) are blue or blue-green deposits that adhere tightly to the surface. Magnesium corrosion products are white and powdery and form in large amounts with significant losses of the base metal. When corrosion occurs beneath a paint system, the surface of the paint appears blistered, bubbled, or distorted.

**9.2.2 Depth Gauge, Mechanical Type.** Depth gages are tools used to measure the depth of corrosion pits and areas reworked for pitting, exfoliation, and other types of corrosion to determine the extent of corrosion damage and the amount of metal removed during rework. If there is a special requirement to use depth gauges for shelters, radomes, or C-E-M equipment, see Figure 4-1 in Chapter 4 of TO 1-1-691.



**Figure 9-1. Visual Evidence of Corrosion**

**9.2.3 Optical Depth Micrometers.** See Chapter 4 of TO 1-1-691 if it is necessary to use a micrometer.



The apparent simplicity of the fluorescent penetrant inspection is deceptive. Very slight variations in the inspection process can invalidate the inspection by failing to indicate serious flaws. It is essential that personnel performing penetrant inspection be trained and experienced in the penetrant process.

**NOTE**

The following inspection methods shall be accomplished only by qualified and certified NDI technicians. Refer to TO 33B-1-1 and the system specific NDI manual for more detailed inspection procedures.

**9.2.4 Fluorescent Penetrate Inspection.** Fluorescent penetrate inspections require components to be cleaned and then treated with a fluorescent penetrating liquid which is capable of entering surface cracks and/or flaws. After removing the penetrant from the surface, a developer (powder or liquid suspension of powder) is applied to absorb penetrant trapped in the cracks or flaws. Under ultraviolet light, the absorbed penetrant is visible directly above the cracks or flaws from which it was drawn out. The penetrant inspection method is used to detect cracking (fatigue and/or other types), intergranular corrosion, and residual corrosion following corrosion removal by grinding or sanding. Intergranular corrosion attack at metallic grain boundaries and the network of very fine cracks it forms are visible in the early stages only with 10X or greater magnification, and developer is not used when evaluating a penetrant indication with a magnifying glass. In addition, if penetrant inspection is used to monitor a surface for adequacy of corrosion removal by grinding or sanding, caution must be exercised because mechanical removal methods can cause smearing which may obscure indications of remaining corrosion. When monitoring corrosion grind-out areas with penetrant, a developer is not used following removal of excess surface penetrant because the area must also be examined with a 10X magnifying glass after a minimum five minute dwell time. When corrosion is no longer detected in a corrosion grind-out area, the inspection process shall be repeated using non-aqueous developer to determine if any cracks are present. See TO 33B-1-1 for further information on fluorescent penetrant inspection

**9.2.4.1 Limitations of Penetrate Inspection.** Penetrates inspection is applicable to all solid, non-porous materials provided the flaw being inspected for is open to the surface of the part. To detect subsurface flaws, another inspection method must be used.



9.2.4.1.1 Restricted Flaw Openings. The penetrate inspection process depends upon the ability of the penetrant to enter and exit the flaw opening. Any factor that interferes with the entry or exit reduces its effectiveness. Organic coatings, such as paint, oil, grease, and resin, are examples of this interference. Any coating that covers or bridges the flaw opening prevents penetrant entry, and even if it does not cover the opening, material at the edge of the opening affects the mechanism of penetrant entry and exit and greatly reduces the reliability of the inspection. Coatings at the edge of the flaw may also retain penetrant causing background fluorescence. An inspection method other than penetrant must be used if the organic coating cannot be stripped or removed from the surface in the area to be inspected.

9.2.4.1.2 Smearred Metal. Mechanical operations, such as abrasive blasting, buffing, wire brushing, grinding, or sanding, can smear orpeen the surface of metals. This mechanical working closes or reduces the surface opening of any existing discontinuities or flaws. Mechanical working (smearing or peening) also occurs during service when parts contact or rub against each other. Penetrant inspection will not reliably indicate discontinuities or flaws when it is performed after a mechanical operation or service that smears or peens the surface. Chemical etching per procedures in TO 33B-1-1 and/or system specific equipment manual is recommended prior to penetrant operations to improve test sensitivity when smearred metal is present.

9.2.4.1.3 Porous Surfaces. Penetrate inspection is impractical on porous materials with interconnected subsurface porosity. The penetrant rapidly enters the pores and migrates through the network. This results in an overall fluorescence or color that masks any potential discontinuity or flaw indications. In addition, removal of the penetrant after the inspection may be impossible. If it is necessary to use an eddy current or an ultrasonic inspection for an unusual requirement, see TO 1-1-691, Chapter 4.

9.2.5 Coin Tap-Test (Non-Destructive Inspection Method). The coin tap-test method is a non-destructive inspection method used to determine delaminations of the inside surfaces of tactical shelter panels (foam-beam and honeycomb) along and between the structural members. A tap hammer (see Chapter 2 of TO 35E4-1-162) shall be used in the inspection. The inspector shall be an experienced tapper. The tapping procedure consists of tapping lightly over the surface of the shelter wall. A hollow sound indicates a proper bond and a dull-thudding sound indicates areas of moisture or delamination. All shelters shall be non-destructively inspected on the inside of the shelter panels for corrosion. See TO 35E4-1-162 for field level and depot instructions of the coin-tap inspection method.

### 9.3 EVALUATION OF CORROSION DAMAGE.

Visually determine if the corrosion is present in an area which has previously been reworked. If the corrosion damage is in a previously reworked area, measure the damage to include the material which has previously been removed. A straight edge and a 10X magnifying glass may be used to assist in determining if an area has previously been reworked. Place the straight edge across the area being examined at various angles and check for irregularities, low spots, or depressions (see Figure 4-5 in Chapter 4 of TO 1-1-691). If any irregularities, low spots, or depressions are found, and a visual determination cannot verify previous rework, closely examine the suspected area and the surrounding area using the 10X magnifying glass. After determining that the area has been previously reworked, evaluate the depth of the previous rework (grind-out) to determine if further metal removal will exceed grind-out limits, affect structure integrity, and require replacement of the structure. Depth measurements can also be made using the depth gages as described in Chapter 4 of TO 1-1-691.

### 9.4 DEGREES OF CORROSION.

Corrosion must be evaluated after the initial inspection and cleaning to determine the nature and extent of repair or rework needed. It is difficult to draw a distinct and specific dividing line among the degrees of corrosion, so reliable evaluation requires sound maintenance judgment. Use the following categories in reporting degrees of corrosion:

9.4.1 Light Corrosion. This degree of corrosion is indicated by the protective coating being scrapped, gouged, or chipped to bare metal or showing the tracks of filiform corrosion in the film and the bare metal showing is characterized by discoloration of surface corrosion and/or pitting to a depth of approximately one mil (0.001 inch) maximum. This type of damage can normally be removed by light hand sanding.

9.4.2 Moderate Corrosion. This degree of corrosion looks somewhat like light corrosion except some blisters or evidence of scaling and flaking of the coating or paint system is present, and the pitting depths may be as deep as 10 mils (0.010 inch). This type of damage is normally removed by extensive hand sanding or light mechanical sanding.

9.4.3 Severe Corrosion. The general appearance of this degree of corrosion is similar to moderate corrosion in the appearance of the coating system but with severe intergranular corrosion cracks and blistering exfoliation with scaling or flaking of the metal surface. The pitting depths are deeper than 10 mils (0.010 inch). This damage must be removed by extensive mechanical sanding or grinding and may require a patch type repair or component replacement.



## CHAPTER 10

### CORROSION PRONE AREAS

#### 10.1 COMMON AREAS.

There are certain corrosion prone areas common to shelters, vans, radomes, and C-E-M equipment. Corrosion prone areas should be cleaned, inspected, and treated more frequently than less corrosion prone areas. The following paragraphs describe the areas and contain illustrations to aid in inspections. However, the list is not complete and should be expanded by referring to the equipment system specific maintenance manuals and maintenance inspection cards for each specific piece of C-E-M equipment, shelter, or radome that show other possible trouble spots.

#### 10.2 DISSIMILAR METALS.

When two dissimilar metals make electrical contact in the presence of an electrolyte, which metal will corrode and the rate at which corrosion occurs depends on the difference in their activities, that is, their positions in Figure 3-16 of Chapter 3 of this manual. The higher a metal is in this table and the greater the difference in activity between the two metals, the faster corrosion occurs. For example, magnesium would corrode very quickly when coupled with gold in a humid atmosphere. But aluminum would corrode very slowly, if at all, in contact with cadmium. A flashlight battery (or dry cell) is an example of galvanic corrosion put to practical use. A zinc battery casing steadily corrodes supplying a steady flow of electrons, but only when the switch is closed. When the switch is open, there is no corrosion because electrons are not able to leave the zinc anode. Pay particular attention to dissimilar metal joints for signs of galvanic corrosion (see Figure 10-1). C-E-M equipment, shelters, and radomes usually contain dissimilar metals. The use of dissimilar metals in the selection of materials and hardware i.e., screws, washers, and nuts, should

be eliminated wherever possible. Where contact between dissimilar metals cannot be avoided, the choice of contacting material and associated hardware material is important. Materials should be chosen such that the part most prone to corrode (anode) is the easiest and least expensive to replace. At bimetallic junctions, where finishes are removed to provide good electrical connection, a protective finish/sealant shall be reapplied to the completed connection after it is made to prevent corrosion. Attaching parts, such as nuts (standard, speed, and self-locking), bushings, spacers, washers, screws (standard and self-tapping), sleeves for shake-proof fastener studs, clamps, bolts, etc., do not need to be painted in detail except when dissimilar metal or wood contact is involved with the materials being joined or exposure to a corrosive interior environment or the exterior environment will occur in service. However, all parts shall be installed wet with sealant.

#### 10.3 FASTENERS.

There are hundreds of fasteners on/in C-E-M equipment and shelter and radome surfaces, and areas around these fasteners are trouble spots. These areas are subject to operational loads and/or moisture intrusion which make the skin material highly susceptible to corrosion at fastener locations (see Figure 10-2). Equipment installation, shipping, or setup strains cause paint to crack around the fasteners which provides a path for corrosive materials to enter the joint between fastener heads and skin panels. Any paint that is not highly flexible will crack to some degree around fasteners. Fasteners should be installed using a corrosive preventative compound, bonding agent, or sealant to prevent corrosion between itself and the attaching structure (see Figure 10-3). See Chapter 4 of TO 35E4-1-162 and Chapter 12 of this manual for sealant application.

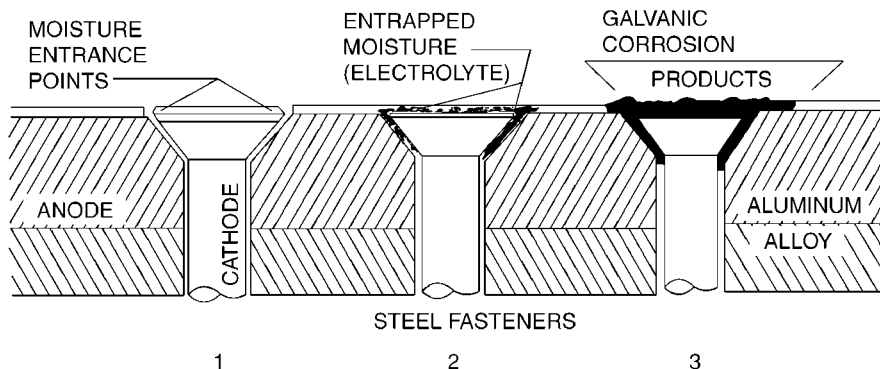

Figure 10-1. Galvanic Corrosion Adjacent To Steel Fasteners

TO 1-1-700

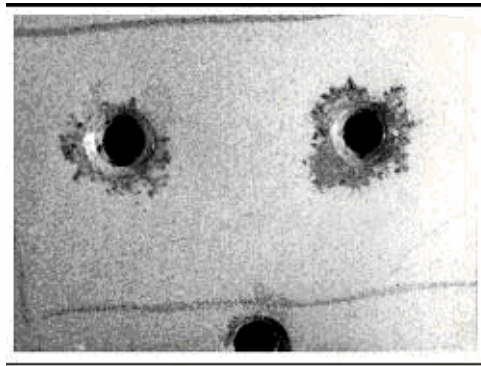

Figure 10-2. Corrosion Around Fasteners

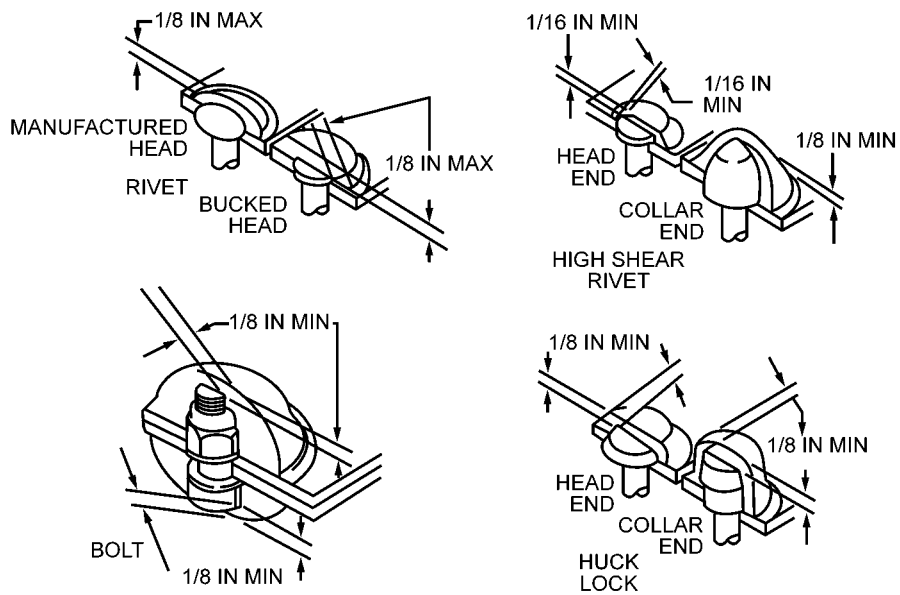

Figure 10-3. Typical Methods of Sealing Fasteners



MIL-PRF-81733, SEALING AND COATING COMPOUND,  
CORROSION INHIBITIVE 48



SAE AMS-S-8802, SEALING COMPOUND  
(POLYSULFIDE) 62

#### 10.4 RIVETS.

Rivets are commonly used fasteners in construction of shelters and electronic and electrical boxes for attaching panels, braces and mounting parts. Those rivets shall be installed wet with MIL-PRF-81733, Type I or IV, Class 1 or 2, Grade A sealant. The exposed rivet head and approximately 1/4 inch of the adjacent structure shall be brush-over-coated with SAE AMS-S-8802 (MIL-S-8802), Class A sealant.

#### 10.5 MATING SURFACES AND CREVICES.

Similar to corrosion around fasteners, corrosion in faying surface areas, crevices, seams, and joints is caused by the intrusion of salt water and/or other corrosive fluids or agents. Entry of fluids by capillary action causes corrosive liquids to flow into the tightest of joints. The effect of corrosion resulting from fluid intrusion into joint areas is usually detectable as bulging of the skin surface. There are several methods to prevent fluid intrusion and corrosion in the mating of metal surfaces or at crevices, joints, and seams.

**10.5.1 Faying Surface Sealing.** Faying surfaces are sealed by applying a sealant to the connecting surfaces of two or more parts and then assembling the parts while the sealant is still wet. It is a very effective seal and should be used for all assembly or reassembly. When possible, it should be used in conjunction with fillet sealing. There are two types of faying surface seals: removable and permanent. Removable seals are used around access doors, removable panels, inspection plates, etc. A removable seal can be formed using a low adhesion sealant that adheres to both surfaces, or by using a high adhesion sealant that adheres to one surface and a parting agent on the mating surface. Permanent seals are created using high adhesion sealants between permanently fastened structures (see Figure 10-4). To create a permanent seal, coat either one or both mating surfaces with a high adhesion sealant before assembling the parts and then assembling them while the sealant is still wet. Apply enough sealant to force a bead to squeeze out along the joint after assembly. Install all fasteners wet with the sealant. Assemble parts within the rated application life and/or assembly life of the sealant while taking into account the effects of temperature and humidity on these times (see Chapter 12 of this manual).

**10.5.2 Fillet Sealing.** Fillet or seam sealing is the most common type of sealing used on support equipment. Fillet seals are used to cover the edges or seams of structural joints along stiffeners or beams, skin panel and wall butt joints, areas where mating surfaces require electrical contact (e.g. antenna to a shelter roof surface), and to seal around fittings and fasteners. This type of sealing is the most easily repaired. It should be used in conjunction with faying surface sealing if possible and in place of it if the assembly sequence restricts the use of faying surface sealing (see Figure 10-5 and Chapter 12 of this manual).

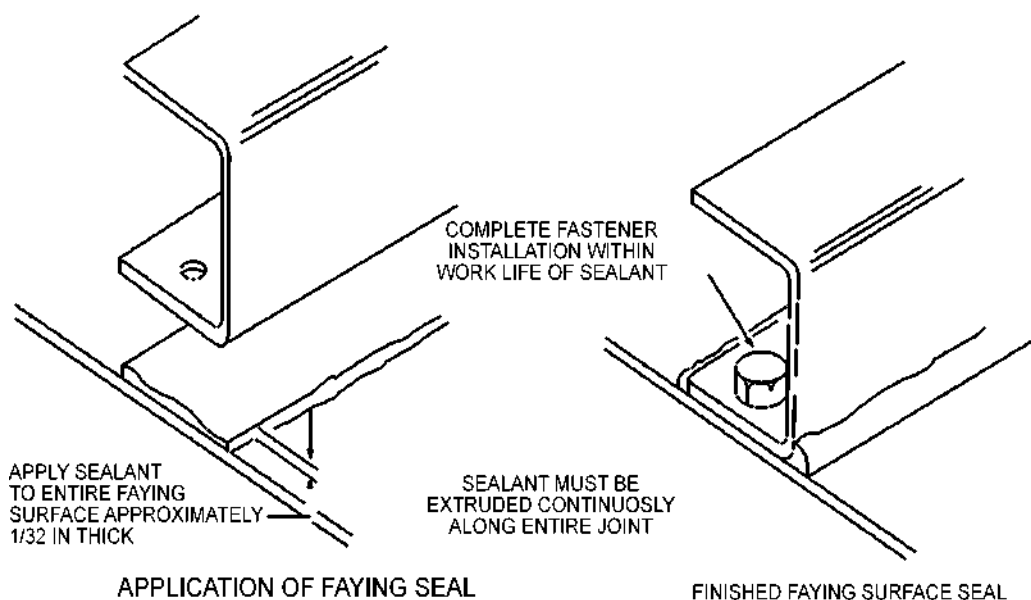

Figure 10-4. Faying Surface Sealing

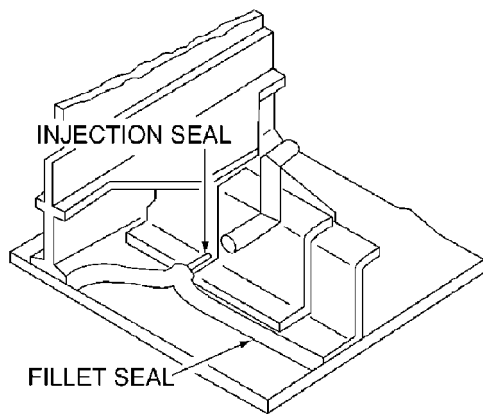

Figure 10-5. Typical Fillet Seal



MIL-PRF-81733, SEALING AND COATING COMPOUND,  
CORROSION INHIBITIVE 48



MIL-PRF-81309, LUBRICANT, CORROSION PREVEN-  
TIVE COMPOUND 46



MIL-PRF-16173, COMPOUND, CORROSION PREVEN-  
TIVE 37



MIL-PRF-32033, LUBRICATING OIL, GENERAL PUR-  
POSE, PRESERVATIVE (WATER-DISPLACING, LOW  
TEMPERATURE) 41



MIL-PRF-63460, LUBRICANT, CLEANER AND PRESER-  
VATIVE 44

## 10.6 SPOT-WELDED ASSEMBLIES.

Spot-welded assemblies are particularly corrosion prone due to entrapment of corrosive agents between the parts of the assemblies (see Figure 10-6). Non-continuous, spot welded joints result in crevices in the non-welded lap areas. Moisture and other corrosives tend to accumulate in these lap areas. Corrosive attack causes skin buckling or spot weld bulging and eventual spot weld fracture (see Figure 10-7). Skin and spot weld bulging may be detected in their early stages by sighting or feeling along spot welded seams. This condition is prevented by keeping potential moisture entry points such as gaps, seams, and holes created by non-continuous spot-welds sealed off either by applying a continuous coating of MIL-PRF-81733, Type IV-12, Class 1, Grade A corrosion inhibiting sealant around the entire periphery of the faying surface area of the parts to be spot welded, assemble the parts together and hold them in place, spot weld the parts together while the sealant is still wet, and allow the sealant to cure before placing the assembly in service. As an alternate to the above procedure, apply a continuous fillet seal of MIL-PRF-81733, Type II, Class 1, Grade A corrosion inhibiting sealant to the joint edges of the spot welded parts after they are spot welded together and allow the sealant to cure before placing the assembly in service. Sometimes sealant cannot be used due to time constraints or unavailability. If so, after parts are spot welded together, apply either MIL-PRF-81309, Type II, MIL-PRF-16173, Grade 3, MIL-PRF-32033, or MIL-PRF-63460 preservative/corrosion preventive compound (CPC) to the joint edges of the spot welded parts, allow it to wick into the faying surface area, and then apply a continuous fillet of MIL-PRF-16173, Grade IV CPC to the joint edges of the spot welded parts. See Chapter 12 of this manual for additional information on sealants and Chapter 7 of this manual for additional information on CPCs. Consult Chapter 1 of TO 31-1-75 for additional information on welding.

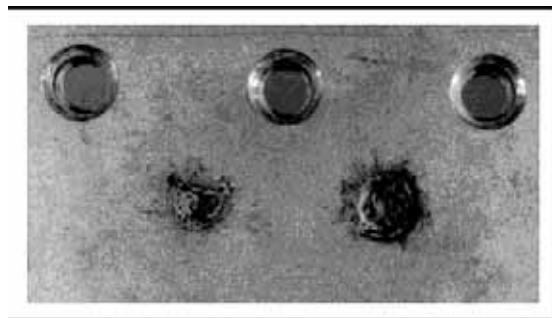
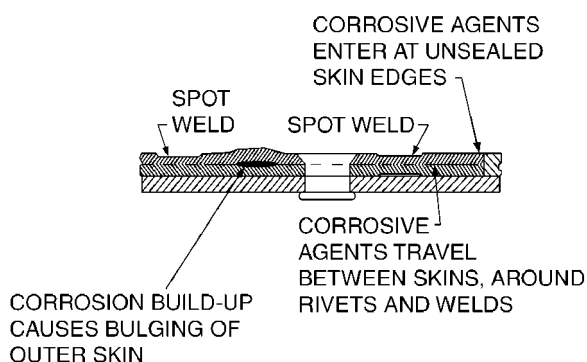

Figure 10-6. Spot Weld Corrosion





**Figure 10-7. Spot Welded Skin Corrosion Mechanism**

## 10.7 HINGES AND LATCHES.

Hinges and latches are highly susceptible to corrosion because of dissimilar metal contact that results from wear and damage to protective metallic coatings. They are natural traps for dirt, salt, and moisture. Door hinges and latches are especially vulnerable to attack. Inspect hinges and latches on shelter and van access doors and vents, and equipment/black boxes, etc., for corrosion and condition of preservatives/lubricants.

**10.7.1 Van and Shelter (Fixed and Mobile) Hinges and Latches.** If corrosion is found, treat as follows:



■ MIL-PRF-680 AND A-A-59601, SOLVENT, DEGREASING, TYPE II AND III 45

- a. Clean affected areas with CCC-C-46, Class 7 cleaning cloth dampened with MIL-PRF-680 or A-A-59601, Type II degreasing/dry cleaning solvent or other cleaner as specified by system-specific manuals or the equipment SPM.
- b. Remove corrosion with A-A-58054, Type I, Grade A or B abrasive mat, or 320 grit abrasive cloths, as appropriate.



TT-I-735, ALCOHOL, ISOPROPYL 65

- c. Wipe residue with CCC-C-46, Class 7 cleaning cloth dampened with TT-I-735 Isopropyl Alcohol and allow to dry.

- d. After corrosion is removed from metal surfaces treat them as follows:



MIL-DTL-81706 (ALODINE), COATING, CHEMICAL CONVERSION 23



Exercise care when using MIL-DTL-81706, Class 1A Chemical Conversion Coating Material, near electronic hardware. It can cause corrosion of delicate electronic devices if not suitably protected.

- (1) Treat aluminum surfaces with MIL-DTL-81706, Class 1A Chemical Conversion Coating Material using procedures in Chapter 7 of this manual.



MIL-C-10578, COMPOUND, CORROSION REMOVING AND METAL CONDITIONING 20

- (2) Treat carbon steel (other than stainless steel/CRES) surfaces with MIL-C-10578, Type VI Brush-On Phosphoric Acid Base Corrosion Removing and Metal Conditioning Compound per procedures in Chapter 7 of this manual.
- (3) Stainless/CRES steel requires no further treatment.



MIL-DTL-85054, COMPOUND, CORROSION PREVENTIVE 25



Do not apply MIL-DTL-85054 to functional areas of hinges and latches as this material dries to a hard film and will cause them to bind and/or seize up.

- e. Prepare bare metal non-moving parts requiring no lubrication for touch-up painting as specified in TOs 1-1-691 and 1-1-8. When environmental conditions or time do not permit, preserve surfaces requiring no lubrication

## TO 1-1-700

with a thin film of MIL-DTL-85054, Type IA or IIA, Clear Water Displacing Corrosion Preventive Compound, and allow it to cure.



MIL-PRF-32033, LUBRICATING OIL, GENERAL PURPOSE, PRESERVATIVE (WATER-DISPLACING, LOW TEMPERATURE)

41



MIL-PRF-63460, LUBRICANT, CLEANER AND PRESERVATIVE

44



Do not use MIL-PRF-63460 corrosion preventive compound, or MIL-PRF-32033 lubricating oil/general purpose preservative, around oxygen or oxygen fittings since fire/explosion may result.

- f. Either in conjunction with corrosion removal or as a stand alone procedure, periodic lubrication of access and/or entry door, panel, and vent hinges and door latches will be accomplished as directed by maintenance inspection and at 6 month intervals by applying either MIL-PRF-32033 or MIL-PRF-63460 water displacing lubricant/preservative/corrosion preventive compound (CPC) to the hinge node joints, hinge pins, and all moving parts of latches. For hinges, this can be done with the hinges assembled, but it is better to remove the hinge pins during lubrication and reinstall them afterwards. During extreme weather or in harsh environments, increase the lubrication interval. Apply a generous quantity of either MIL-L-63460 (preferably) or MIL-PRF-32033 water displacing, corrosion preventive compound (CPC), actuate hinges and latches several times to make sure that the CPCs and lubricants penetrate all crevices thoroughly, and then wipe off excess from exterior surfaces.

10.7.2 Equipment Hinges and Latches. If corrosion is found, treat as follows:



MIL-PRF-680 AND A-A-59601, SOLVENT, DEGREASING, TYPE II AND III

45

- a. Clean affected areas with CCC-C-46, Class 7 cleaning cloth dampened with MIL-PRF-680 or A-A-59601, Type II Degreasing/Dry Cleaning Solvent, or other cleaner as specified by system-specific manuals or the equipment SPM.
- b. Remove corrosion with A-A-58054, Type I, Grade A or B Abrasive Mat, or 320 grit abrasive cloth, as appropriate.



TT-I-735, ALCOHOL, ISOPROPYL

65

- c. Wipe residue with CCC-C-46, Class 7 cleaning cloth dampened with TT-I-735 Isopropyl Alcohol and allow to dry.
- d. After corrosion is removed from metal surfaces treat them as follows:



MIL-DTL-81706 (ALODINE), COATING, CHEMICAL CONVERSION

23



Exercise care when using MIL-DTL-81706, Class 1A Chemical Conversion Coating Material, near electronic hardware. It can cause corrosion of delicate electronic devices if not suitably protected.

- (1) Treat aluminum surfaces with MIL-DTL-81706, Class 1A Chemical Conversion Coating Material, using procedures in Chapter 7 of this manual.



MIL-C-10578, COMPOUND, CORROSION REMOVING AND METAL CONDITIONING

20

- (2) Treat carbon steel (other than stainless steel/CRES) surfaces with MIL-C-10578, Type VI Brush-On Phosphoric Acid Base Corrosion Removing and Metal Conditioning Compound per procedures in Chapter 7 of this manual.

- (3) Stainless/CRES steel requires no further treatment.



MIL-DTL-85054, COMPOUND, CORROSION PREVENTIVE 25



Do not apply MIL-DTL-85054 to functional areas of hinges and latches as this material dries to a hard film and will cause them to bind and/or seize up.

- e. Prepare bare metal non-moving parts requiring no lubrication for touch-up painting as specified in TOs 1-1-691 and 1-1-8. When environmental conditions or time do not permit, preserve surfaces requiring no lubrication with a thin film of MIL-DTL-85054, Type IA or IIA, Clear, Water Displacing, Corrosion Preventive Compound, and allow it to cure.



MIL-PRF-81309, LUBRICANT, CORROSION PREVENTIVE COMPOUND 46



MIL-L-87177, LUBRICANT, CORROSION PREVENTIVE COMPOUND, WATER DISPLACING 32



MIL-DTL-85054, COMPOUND, CORROSION PREVENTIVE 25



MIL-PRF-63460, LUBRICANT, CLEANER AND PRESERVATIVE 44



MIL-PRF-16173, COMPOUND, CORROSION PREVENTIVE 37



MIL-PRF-32033, LUBRICATING OIL, GENERAL PURPOSE, PRESERVATIVE (WATER-DISPLACING, LOW TEMPERATURE) 41



Do not use MIL-PRF-81309, MIL-DTL-85054, MIL-DTL-63460, and MIL-PRF-16173 corrosion preventive compounds, or MIL-PRF-32033 lubricating oil/general purpose preservative, around oxygen or oxygen fittings since fire/explosion may result.

- f. Either in conjunction with corrosion removal or as a stand alone procedure, periodic lubrication of access door or case closure panel hinges and latches (see Figure 10-8) will be accomplished as directed by maintenance inspection and at 6 month intervals with either MIL-PRF-81309, Type II or III or MIL-L-87177, Class B Water-Displacing, CPC applied either by brush or spray. Apply a generous quantity of either MIL-PRF-81309, Type II or III or MIL-L-87177, Class B water displacing CPC, actuate hinges and latches several times to make sure that the CPCs and lubricants penetrate all crevices thoroughly, and then wipe off excess from exterior surfaces.



Figure 10-8. Electronic Shelter Door

## TO 1-1-700

## 10.8 STEEL CABLES.

Whether made of plain low carbon steel or stainless steel (CRES), cables are highly susceptible to corrosion. The presence of bare spots or cracks (see Figure 10-9) in the plastic cladding on clad cables and gaps where the protective CPC coating is missing on other cables are the main contributing factors to the corrosion of cables. Dirt, grime, and rust that collect between cable strands lead to more severe corrosion and wear that eventually cause cable failure. Inspect accessible cables for these conditions as well as for signs of wear, fraying, binding, kinks, excessive dirt/grease build-up, and corrosion. Check the cable for corrosion by twisting the fibers and checking for rust in the interior of the cable. Use the following procedures to treat steel cable corrosion:

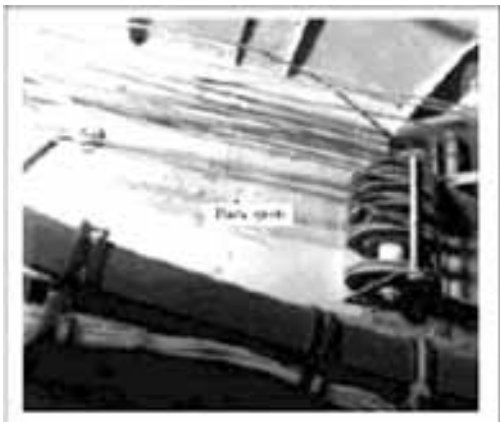

Figure 10-9. Steel Control Cables



MIL-PRF-680 AND A-A-59601, SOLVENT, DEGREASING, TYPE II AND III 45



- Consult the applicable system specific maintenance manual for cable de-tensioning and tensioning requirements prior to performing any maintenance on pre-tensioned cables.
- Do not use metallic wools to clean steel cables. The use of metallic wool will cause dissimilar metal particles to become embedded in the cables and create further corrosion problems (galvanic corro-

sion). Use only a clean cloth dampened with, MIL-PRF-680 or A-A-59601, Type II or III Dry Cleaning/Degreasing Solvent to clean steel cables. Excessive solvent will remove internal cable lubricant and allow the cable strands to abrade and further corrode.

- If the surface of a cable is corroded, relieve cable tension and carefully force the cable open by reverse twisting. Visually inspect the interior. Corrosion on the interior strands constitutes failure and the cable must be replaced.
- If no internal corrosion is detected, remove loose external rust/corrosion with a clean, dry, coarse-weave rag or fiber brush and clean the cable with a clean cloth dampened with MIL-PRF-680 or A-A-59601, Type II or III Dry Cleaning/Degreasing Solvent or other cleaner as specified by system-specific manuals or the equipment SPM.



MIL-PRF-81309, LUBRICANT, CORROSION PREVENTIVE COMPOUND 46



MIL-L-87177, LUBRICANT, CORROSION PREVENTIVE COMPOUND, WATER DISPLACING 32



MIL-PRF-16173, COMPOUND, CORROSION PREVENTIVE 37

- After thorough cleaning, apply a thin film of either MIL-PRF-81309, Type II; MIL-L-87177, Type I or II, Grade B; or MIL-PRF-16173, Class II, Grade 4 Water Displacing CPC to the cable surface either by aerosol spray or with a cloth dampened with the CPC. Follow with a liberal amount of MIL-PRF-16173, Class II, Grade 4 CPC applied with a non-metallic bristle brush. Wipe off any excess CPC as excessive CPC build up will interfere with the operation of cables at fairleads, pulleys, or grooved bell-crank areas.

## 10.9 WATER ENTRAPMENT AREAS AND DRAIN HOLES.



Drain holes should not be drilled by organizational or intermediate-level personnel unless authorized by the equipment System Program Manager (SPM) for the C-E-M equipment or its protective shelters, vans, and radomes.

Corrosion is often found in water entrapment areas where proper drainage does not exist, where drain holes are not provided, and/or protective coatings are damaged. In many cases, drain holes located in water entrapment areas are ineffective either because of improper location or because they are plugged by sealants, fasteners, dirt, grease, or debris. Ensure all drain holes are open by inserting a probe, such as a pipe cleaner. The plugging of a single drain hole or the altering of the attitude of the equipment can trigger corrosion if salt water or other corrosives remain for any appreciable length of time in these entrapment areas. Frequent inspection and cleaning of low-point drains is a standard requirement. Take care to ensure that protective coatings remain intact in these areas. Water may accumulate in these areas following the washing or rinsing of equipment. If this is a recurring problem, develop procedures to prevent water accumulation.

## 10.10 BATTERY COMPARTMENTS AND BATTERY VENT OPENINGS.



Batteries must be replaced at their prescribed time change interval to ensure good equipment operation and to prevent corrosion in the battery compartment and surrounding areas, sometimes very severe, caused by the physical breakdown of the battery and electrolyte leakage.

Batteries are used many times in C-E-M equipment as backup power source to allow for temporary operation of the equip-

ment and/or to prevent loss of a computer program when there is power outage. In spite of protective paint systems, corrosion preventive compounds, and venting provisions, battery compartments are high corrosion problem areas (see Figure 10-10). If corrosion does occur in the battery compartment, consult Chapter 6 of TO 1-1-689-3, Chapter 7 of TO 1-1-691, and Chapter 5 of TO 35E4-192-2 for proper treatment procedures.



**Figure 10-10. Corroded Battery Compartment**

## 10.11 NATURAL AND SYNTHETIC RUBBER PARTS.

Natural and synthetic rubber are susceptible to attack by fungi, microbes, ozone, and ultraviolet light; and they deteriorate rapidly when exposed to direct sunlight. Natural and synthetic rubber shall not be painted or oiled. As a general rule, grease should not be applied to rubber parts, but some parts, such as O rings, require a grease coating (consult the appropriate system specific maintenance manual). Many types of rubber are subject to fungus growth (e.g. mold, mildew) which can cause deterioration of the rubber and corrosion of surrounding metal surfaces. If fungus and/or bacteria are noted on rubber parts such as electrical wiring jackets, rubber jacketed cords and cables, rubber grommets, O rings, etc., clean the parts and remove the fungus and bacteria per these procedures:



## TO 1-1-700



MIL-PRF-63460, LUBRICANT, CLEANER AND PRESERVATIVE 44



■ MIL-PRF-680 AND A-A-59601, SOLVENT, DEGREASING, TYPE II AND III 45



TT-I-735, ALCOHOL, ISOPROPYL 65



- MIL-PRF-63460 Cleaner/Lubricant/Preservative (CLP), shall not be used to clean or lubricate rubber or other elastomeric parts because it contains solvents which attack rubber O rings and other elastomeric parts.
  - • MIL-PRF-680 and A-A-59601, Type II or III solvents shall not be used to clean natural or synthetic rubber parts as they can cause damage to these rubber components.
- a. Apply a mixture of one part TT-I-735, Isopropyl Alcohol, and one part distilled water to affected areas with a CCC-C-46 Cleaning Cloth; an A-A-289 (style optional) Acid Brush; a toothbrush or other type soft, non-metallic bristle brush as appropriate.
  - b. Wipe or scrub affected area until contaminants have been dislodged.
  - c. Remove residue by blotting or wiping with a CCC-C-46 Cleaning Cloth. Inspect affected areas for signs of residues and contaminants.
  - d. Discard contaminated cloths and solvents in approved disposal containers after cleaning operation to avoid contamination of other components.
  - e. Repeat process until all contaminants are removed.



MIL-PRF-81309, LUBRICANT, CORROSION PREVENTIVE COMPOUND 46



MIL-L-87177, LUBRICANT, CORROSION PREVENTIVE COMPOUND, WATER DISPLACING 32

## 10.12 ELECTRICAL COMPONENTS AND OTHER COMPONENTS.

Almost all corrosion problems on electrical and electronic equipment are caused by moisture intrusion at the connector or lead-in attachment points on cases and covers. While the design of this equipment is fixed, corrosion can be prevented by spraying MIL-PRF-81309, Type III or MIL-L-87177, Type I, Grade B Avionics Grade, Water Displacing CPC into the pin and/or pin receptacle end of the connectors prior to mating the connector halves, and on the connector shells after mating the connector halves. Consult Chapter 7 of TO 1-1-691 for corrosion protection of electrical connectors and Chapter 6 of TO 1-1-689-3 for cleaning and preservation. Potting compounds are also used to protect electrical connectors from corrosion, contamination and arcing by the exclusion of moisture, stray particles, and liquids. Chapter 8 of this manual provides the recommended potting compounds to use.

## 10.13 BONDING/GROUNDING.

Electrical bonding provides a low resistance electrical path between two or more conductive units or components. Grounding is a form of bonding that utilizes the primary structure as a portion (return path) of the electrical circuit (see Figure 10-11). See Chapter 1 of TO 31-1-75 and Chapter 8 of this manual for further information on grounding. Bonding may serve one or all of several functions:

- a. Provide a common ground for the proper electrical functioning of the units involved.
- b. Provide a path to minimize lightning strike damage.
- c. Prevent the buildup of static potentials that could result in a spark discharge.
- d. Minimize static and stray currents in units involved.
- e. Prevent a unit from emitting electromagnetic energy that would interfere with other units and provide a signature for enemy detection and recognition.



- f. Shield equipment from outside electromagnetic interference (EMI) sources.



**Figure 10-11. Bonding Cable Between Frame and Door**

10.13.1 Corrosion Prevention and Treatment for Grounding and Bonding Connections. The bonding and grounding straps used on communications and electronics equipment are highly susceptible to galvanic corrosion. In most cases, the bonding or grounding strap is made of a metal that is dissimilar to the mating surface. This creates a galvanic couple that in the presence of moisture will corrode rapidly.



MIL-PRF-81733, SEALING AND COATING COMPOUND, CORROSION INHIBITIVE 48

10.13.2 Electrical Bonding/Grounding. See Chapter 8 of this manual for the corrosion control measures for electrical bonding/grounding, which describes the best hardware and techniques to be used when cleaning, repairing or replacing existing connections. After the grounding or bonding connection has been made, overcoat the entire connection, including all bare areas on the metal surface, with MIL-PRF-81733, Type II, Class 1 or 2, Grade A sealant (see Chapter 8 of this manual for additional information). See TO 00-25-234 for proper procedures to be used in external earth grounding of permanent and portable structures.

#### 10.14 ANTENNAS AND RADAR SURFACES.

Antenna and radar dish surfaces, hardware, connectors and electronic systems are normally exposed to fairly severe environments with dissimilar (galvanic) corrosion occurring at antenna attachment points (see Figure 10-12). Without adequate corrosion protection, these systems can fail via shorts, open circuits, loss of dielectric strength, signal attenuation, poor bonding, or electromagnetic interference (EMI). The area around the antenna mounting to a shelter or van is susceptible to moisture intrusion from rain and condensation. Dissimilar

metal (galvanic) corrosion often occurs at antenna attach points. Inspection and treatment processes are outlined in Chapter 6 of TO 1-1-689-3. Refer to the system specific maintenance manuals for information on paint touch-up and finishing. Apply paint and coatings per procedures in TO 1-1-8.



**Figure 10-12. ANTPS-75 Antenna Radar Surface**

#### 10.15 VAN AND TRAILER UNDERCARRIAGES.

10.15.1 Shelter Underbody. The undercarriage or underbody of tactical shelters are susceptible to corrosion (see Figure 10-13). Inspect the underbody coating for chipped, cracked, or loose coating and bare metal. If the deficiency is determined to warrant repair, see the system specific shelter maintenance manual for cleaning, repair, treatment, and painting.



MIL-T-81772, THINNER, POLYURETHANE 70

#### **WARNING**

Blowing dry air or nitrogen to evaporate solvent can create airborne particles which may enter the eyes. Air pressure for drying shall not exceed 30 PSI at the nozzle. Eye protection is required. Failure to comply may cause personnel injury resulting from exposure to airborne particles.

- a. Completely clean the undercarriage. Scrape off defective coating using a putty knife and Specification MIL-T-81772, Type I, Polyurethane Coating thinner.
- b. Mask affected areas in accordance with TO 1-1-8.

## TO 1-1-700



DOD-P-15328, PRIMER, PRETREATMENT (WASH) FOR METALS 16



MIL-C-8514, PRIMER, PRETREATMENT (WASH) FOR METALS 21



MIL-PRF-23377, TYPE I & II, PRIMER, EPOXY CHEMICAL AND SOLVENT RESISTANT 38



MIL-P-53030, PRIMER, EPOXY, WATER REDUCIBLE, LEAD, CHROME FREE 35



MIL-PRF-85285, COATING, POLYURETHANE, HIGH SOLIDS 50

- c. Touch up the treated area by applying underbody coating specified by the system specific maintenance manual. If not specified use one coat of DOD-P-15328 or MIL-C-8514 Wash Primer, on the bare metal; one coat of MIL-PRF-23377, Type I, Class C Epoxy Primer or MIL-P-53030 Epoxy Primer; and one coat of MIL-PRF-85285 Polyurethane Topcoat. Application shall be per procedures in Chapter 7 of this manual.



TT-I-735, ALCOHOL, ISOPROPYL 65

**NOTE**

If tape adhesive will not come off, use TT-I-735, Isopropyl Alcohol, to assist with the removal.

- d. De-mask as soon as possible after coating application.

**10.15.2 Shelters Skids.** Skids are attached to the underside of the shelters. When the shelters are deployed or in service, they rest on dirt, gravel, or concrete and experience corrosion due to damage to the protective coating. Organizational/field level repair of tactical shelter skids are very limited, and damaged shelter skids are to be referred to depot for repair or replacement. See the system specific shelter maintenance manual and the general instructions below for organizational and depot replacement and repair procedures for cleaning, repair, treatment and painting of shelter skids.

**10.15.2.1 Repair of Damaged Shelter Skids.** Damaged shelter skids secured with bolts or rivets must be removed, repaired, and secured with mounting bolts. Follow the procedures below when repairing damaged shelter skids.

- a. Elevate the shelter and remove the damaged skid(s).

**WARNING**

Drilling and cutting operations create metal chips which may enter the eyes. Eye protection is required.

- b. Drill out any damaged blind nuts, as outlined in Chapter 3 of TO 35E4-1-162.
- c. Install 5/16-inch stainless steel blind nuts of appropriate length in the shelter bottom as outlined in Chapter 3 of TO 35E4-1-162.
- d. Prepare a sheet aluminum alloy spacer 0.001 to 0.003 inch thinner than the head of the blind nut.



**Figure 10-13. Corrosion Undercarriage of Shelter**

**WARNING**

Drilling and cutting operations create metal chips which may enter the eyes. Eye protection is required.

- e. Use the skid as a template to mark the spacer and drill holes equivalent to the diameter of the blind nut head.
- f. Position the spacer and skid, and secure by tightening the mounting bolts with lock washers and nuts into the blind nuts.
- g. Apply a fillet seal to the skid seams and a topcoat seal over the mounting hardware.

**10.15.2.2 Replacing Damaged Shelter Skids.** Damaged shelter skids secured with rivets must be removed and secured with mounting bolts. Follow the procedures below when replacing damaged shelter skids.

**WARNING**

Drilling and cutting operations create metal chips which may enter the eyes. Eye protection is required.

- a. Drill out the e-inch rivets and remove the shelter skids.

- b. Use e-inch rivnuts of appropriate length, and install the rivnuts (dipped in the bonding agent specified in the system specific MK-679/G shelter maintenance manual) in the shelter bottom with the applicable rivnut heading tool as instructed in paragraph 30 of the system specific MK-679/G shelter maintenance manual.
- c. Prepare a sheet aluminum alloy spacer 0.001-0.003 inch thinner than the head of the rivnut.

**WARNING**

Drilling and cutting operations create metal chips which may enter the eyes. Eye protection is required.

- d. Use the skid as a template to mark the spacer and drill holes equivalent to the diameter of the rivnut head.
- e. Position the spacer and skid and secure the spacer and skid by tightening the mounting bolts into the rivnuts.
- f. Prime and paint the exposed aluminum alloy surfaces per directions in MIL-DTL-14072 with application procedures per Chapter 7 of this manual.

**10.16 VAN AND TRAILER ATTACHMENT POINTS (INCLUDING LIFT RINGS).**

Lift, tow, and tie-down fittings are normally mounted on shelter corners, on end walls, and on roof panels. The lift rings and mounts are designed for lifting the complete shelter with internally mounted and stowed equipment. Because of the severe loads placed on all ring fittings, the ring, mounts, and attachment hardware must be in good mechanical condition and properly secured. If the rings are deformed or exhibit weld cracks, they must be replaced by depot. The lift rings on the C-E-M shelters are susceptible to corrosion due to the extreme heavy pressure/stress applied to the rings when the shelters are moved and setup in the field. The heavy use of the rings causes the protective coating to crack allowing moisture to enter and begin to initiate corrosion. If the lift rings and fittings exhibit rust or surface corrosion, but are otherwise sound, the fitting should be cleaned to bare metal and refinished. Refer to paragraph 3.13.3 and Table 3-9 in TO 35E4-1-162 for the required paint system and apply it per procedures in Chapter 7 of this manual.

## TO 1-1-700



MIL-PRF-16173, COMPOUND, CORROSION PREVENTIVE 37

10.16.1 Corrosion Prevention and Control for Lift Rings. Inspect the lift rings for corrosion/rusting at periodic inspections. If rusting is not present, reapply a film of MIL-PRF-16173, Class II, Grade 4 CPC to areas on the lift rings where the CPC film has worn away. If corrosion/rusting is noted proceed as follows:



MIL-C-43616, CLEANING COMPOUND, AIRCRAFT 74

- a. Remove all remaining CPC from the tie down rings by spraying them with MIL-C-43616, Class 1A solvent emulsion cleaner and wiping the surface with a cotton cloth per procedures in Chapter 3 of TO 1-1-691.
- b. Remove corrosion from remaining hardware with stainless steel brush or A-A-58054, Type I, Grade C Abrasive Mat per procedures in Chapter 5 of TO 1-1-691.



DOD-P-15328, PRIMER, PRETREATMENT (WASH) FOR METALS 16



MIL-C-8514, PRIMER, PRETREATMENT (WASH) FOR METALS 21



MIL-PRF-23377, TYPE I & II, PRIMER, EPOXY CHEMICAL AND SOLVENT RESISTANT 38



MIL-P-53030, PRIMER, EPOXY, WATER REDUCIBLE, LEAD, CHROME FREE 35



MIL-PRF-85285, COATING, POLYURETHANE, HIGH SOLIDS 50

- c. Solvent wipe the surface of lift rings to remove all grease, oil, and foreign materials per procedures in Chapter 3 of TO 1-1-8. Apply one coat of DOD-P-15328 or MIL-C-8514 Wash Primer on the bare metal; one coat of MIL-PRF-23377, Type I, Class C Epoxy Primer or MIL-P-53030 Epoxy Primer; and one coat of MIL-PRF-85285 Polyurethane Topcoat (color to match) to the surface of lift rings per procedures in TO 1-1-8 and Chapter 7 of this manual.



MIL-PRF-81733, SEALING AND COATING COMPOUND, CORROSION INHIBITIVE 48

- d. Remove loose fittings for inspection and replace the bolts only after inspecting the threaded inserts (blind nuts) for sound threads. Check for spinning blind nuts, and, if necessary, repair in accordance with Chapter 4 of TO 35E4-1-162. Apply MIL-PRF-81733, Type II, Class 1, Grade A sealant under bolt heads at installation and smooth the squeeze-out to a continuous fillet around the bolt head after the bolt is installed.

## 10.17 RAZOR EDGE DOORS.

Vans and shelters which house highly sensitive electrical equipment may have what is called a "Razor Edge" or "Knife Edge" door. These doors are usually identified by a rubber seal inserted in the outer edge of the door and a lip extending off the mating surface of the van or shelter.

10.17.1 This lip is bare of primer and paint with a coating of cadmium plating extending from the edge back 1/4" to 1/2" onto the surface of the lip. The edge mates with the rubber seal which has metal flakes or particles embedded in it to make a continually grounded contact.

10.17.2 Cadmium plating is used as a coating to protect steel parts and to provide a compatible surface when a part is in contact with other materials. Attack on cadmium is evidenced by brown to black mottling of the surface or as white powdery corrosion products. When cadmium shows mottling and isolated voids or cracks in the coating, the plating is still performing its protective function and continues to protect the steel until such time as actual iron rust appears.

10.17.3 If the plating surface is broken during normal usage, the cadmium plate being anodic to the base metal will corrode preferentially and sacrificially protect the base metal.

10.17.4 The removal of corrosion from cadmium plated surfaces shall be limited to the removal of the plating and the base metal corrosion products from the localized area of the underlying base metal. Avoid removing undamaged cadmium plating adjacent to the corroded area.

10.17.5 The preferred method for removing corrosion from cadmium plating for field level is by the application of a chemical corrosion remover. The procedures for the application and use of chemical removers can be found in Chapter 5 of TO 1-1-691.

#### NOTE

- The mechanical procedures listed in Chapter 5 of TO 1-1-691 shall be used for depot level treatment of localized corroded areas on cadmium plated surfaces with reapplication of cadmium plating and a protective coating after corrosion removal as required.
- When the use of organic finishes or the thickness of the organic finish will impair the normal operation of a part, severely corroded parts must be removed and replaced.
- Where facilities, equipment, and trained personnel are available, areas of parts with severely corroded cadmium plating shall be replated by brush plating per MIL-STD-8651 in accordance with procedures in TO 42C2-1-7.
- When high strength steels are being replated, use only those specialized procedures authorized for high strength steels as many plating solutions can cause hydrogen embrittlement of these materials.

10.17.6 Once all corrosion has been removed and the area is clean the area should be replated with cadmium as required.

#### 10.18 MAGNESIUM ALLOY COMPONENTS.

Magnesium alloys are used in C-E-M systems as antennas, structures, chassis, supports, and frames (radar). Magnesium alloys are the lightest structural metals used for construction. These alloys are highly susceptible to corrosion, which appears as white, powdery mounds or spots when the metal surface is exposed to the environment without a protective finish (see Figure 10-14). The normal oxide-carbonate film formed on magnesium alloys does not provide sufficient corrosion protection even in the mildest environment. The rate of

corrosion of a magnesium alloy increases when the alloy is immersed in water or periodically subjected to moisture. Corrosion may also be accelerated by dissimilar metal couples and when conductive contaminants are dissolved in water that is in contact with the magnesium alloy surface. Corrosion of magnesium alloys can be greatly diminished by the use of the proper protective finish. See Chapters 3 and 6 of TO 1-1-8 for instructions on surface preparation, treatment, and coating systems for magnesium. When required to treat magnesium alloys, proceed as follows:

- a. Clean surfaces to be treated to obtain a water break-free surface per procedures in Chapter 3 of TO 1-1-8.
- b. Apply an SAE AMS-M-3171, Type VI Chromic Acid Brush, on treatment to the area of the part being worked per procedures in Section II of Chapter 5 in TO 1-1-691.



MIL-PRF-23377, TYPE I & II, PRIMER, EPOXY CHEMICAL AND SOLVENT RESISTANT

38



MIL-PRF-85285, COATING, POLYURETHANE, HIGH SOLIDS

50

- c. Apply two coats of MIL-PRF-23377, Type I Class C Epoxy Primer and two coats of MIL-PRF-85285 Polyurethane Topcoat per procedures in TO 1-1-8 (color to match) to the pretreated surfaces.

#### 10.19 EMI SHIELDING.

EMI involves the interaction of electromagnetic energy (electric or magnetic fields) with the circuitry of an electronic device. Currents or voltages caused by EMI can couple with digital signal lines and produce erroneous data. Analog devices can also malfunction as a result of EMI. Corrosion is a major cause of EMI shielding deterioration. Corrosion protection typically relies on oxides, organic coatings, and nonconductive films. Conversely, EMI protection requires a conductive path (see Figure 10-15). A typical low electrical resistance joint of silver and aluminum is a dissimilar metal couple that is highly susceptible to galvanic corrosion. Corrosion produces nonconductive films allowing EMI intrusion and degrades the load bearing capabilities of a structure. See Chapter 8 of TO 1-1-689 and Chapters 3 and 8 of this manual which discusses the effects of corrosion on EMI, and corrosion prevention, treatment and control for EMI shielding.



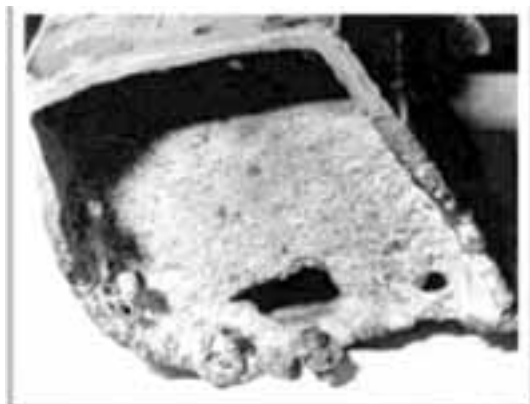

**Figure 10-14. Magnesium Corrosion Products**



**Figure 10-15. EMI Bonding Washers for Electronics**

## 10.20 ELECTROSTATIC DISCHARGE (ESD) COMPONENTS.

Corrosion can degrade the electrical and mechanical properties of ESD protection systems. The exposure of ESD devices/ ESD protection systems to various environmental conditions can significantly increase their susceptibility to damage from the discharge of static electricity. Under field service conditions, military avionics experience corrosion between metal surfaces such as electrical bonding/grounding connections. This problem is two-fold. First, corrosion between metal surfaces in avionics creates structural weaknesses that undermine its effectiveness to shield ESDS components from induced potentials. Second, the corrosive process creates nonconductive products that decrease the paths of conduction of static charge away from the device or assembly (see Figure 10-16). Although no valid method of evaluating the effect of corrosion on ESD sensitivity exists presently, certain trends can be identified. The performance of ESD protection for enclosed avionic equipment can degrade over time. This occurs often after only 3 or 4 months of exposure to the field environment and normal use. Galvanic corrosion is usually the principal form of attack. This type of corrosion can rapidly destroy a bonding connection if suitable precautions are not observed (refer to Chapter 7 of TO 1-1-689-3 and Chapter 8 of this manual). Damage to bonding/grounding hardware can cause the buildup of static potentials that could result in a spark discharge. Without regular maintenance, the buildup of metal oxides, absorbed atmospheric pollutants, dust, and field debris will also contribute to ESD shielding degradation of the avionic enclosure. This buildup introduces a nonconductive film between electrical contact materials which can often severely degrade ESD protection. See Chapter 9 of TO 1-1-689-3 and Chapters 3 and 8 of this manual for the corrosion effects on ESD and the corrosion prevention, treatment, and control for ESD.



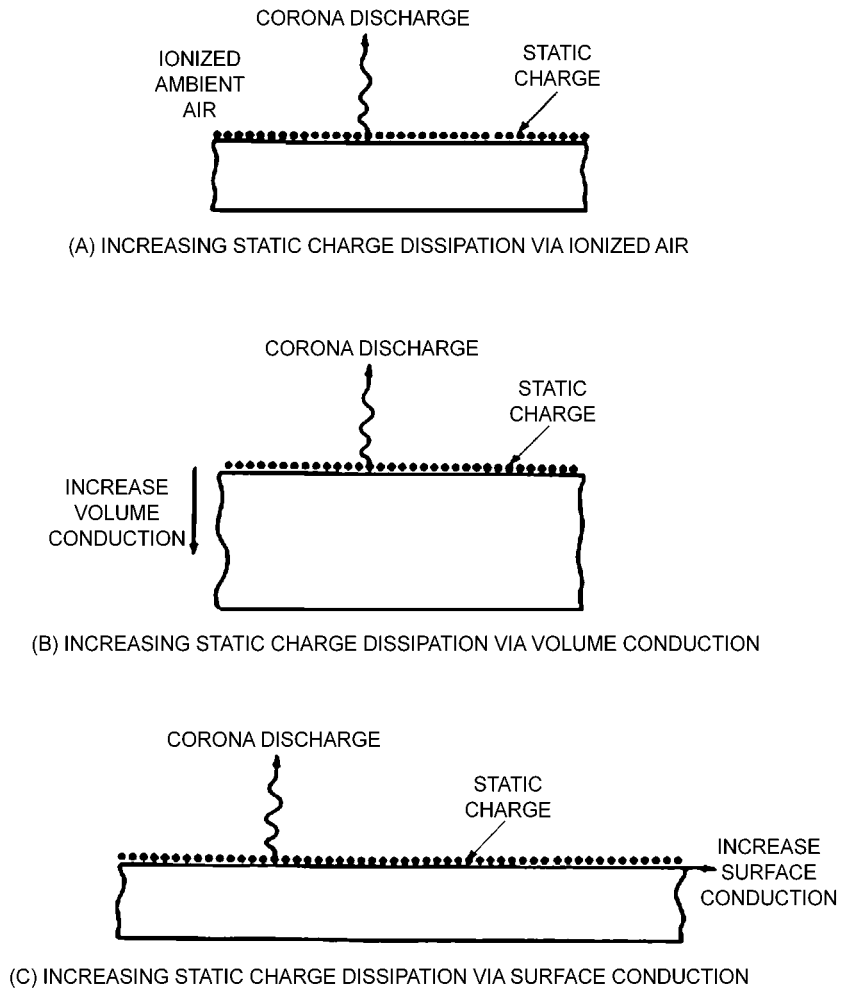

Figure 10-16. Dissipation of Static Charge



## CHAPTER 11 CORROSION REMOVAL

### 11.1 GENERAL.

This chapter covers procedures for corrosion removal and surface treatment. When corrosion is detected, a specific and immediate corrective action is required. Each type of corrosion has its own peculiarities and requires special treatment. Complete treatment involves a thorough inspection of all corroded areas and evaluation of the corrosion damage (refer to Chapter 9 of this manual), paint removal per TO 1-1-8, corrosion removal per this chapter and TO 1-1-691, application of chemical surface treatments per this chapter, sealing (refer to Chapter 12 of this manual), and application/touch-up of protective paint finishes per TO 1-1-8 and Chapter 7 of this manual.

**11.1.1 Training.** Personnel assigned to perform corrosion removal corrective maintenance tasks shall be specially trained in the use of chemical paint removers specified in TO 1-1-8; abrasive materials, powered and hand tools, depth and area measurement of metal removed outlined in this chapter and in TO 1-1-691; and determination of damage limits from the applicable system specific maintenance manuals. Inadequate training will lead to further damage of equipment and poses a safety hazard to the individual.

**11.1.2 Corrosion Risk.** Parts including housings, covers, supports, brackets, cabinets, and chassis are required for structural support and mounting bases for electrical and electronic components. Corrosion on these parts should be treated as soon as possible to eliminate long term deterioration. Severe corrosion usually results from coating failure caused by handling or environmental exposure and subsequent attack of exposed metal. The corrosion attack is caused by exposure to elements such as moisture, corrosive deposits, and/or microbial contamination.

**11.1.3 Maintenance Level.** Major repairs should be performed at Depot Level maintenance. Preventive maintenance, corrosion control, and touchup procedures should be accomplished at the Intermediate Level maintenance and/or Organizational/Unit Level maintenance.

### 11.2 CORRECTIVE ACTIONS.

Corrective maintenance depends on: the type of surface involved (metallic or composite); the area of the damaged surface (small corrosion spot or large corroded area); and the degree of corrosion, as determined per Chapter 9 of this manual.

**11.2.1 Exposure.** Composite materials, such as fiberglass or graphite/boron epoxy matrix structures, shall not be exposed to chemical paint removers, but shall only be scuff sanded to the primer coat.

**11.2.2 Mechanical Procedures.** Since composite materials do not corrode, corrosion removal techniques are not applicable and shall not be used. Corrosion shall always be removed by the mildest effective technique. For mechanical procedures specific to the various metal alloys, refer to Table 11-1 and Table 11-2.

### 11.3 CORROSION REMOVAL METHODS.

Corrosion can be removed by either mechanical or chemical methods. Certain factors must be considered prior to starting any corrosion removal operation. The most important factor to consider is that corrosion products must be removed completely without causing additional damage to the structure during the process. This can be accomplished by first removing all corrosion visible through a 10X magnifying glass, then removing an additional two mils (0.0020 inch) to ensure that all deposits have been eliminated. Failure to remove all corrosion allows the corrosion to continue even after affected surfaces are refinished. Additional factors to consider are:

- a. Before attempting to remove corrosion products, strip the paint from the area to be worked and clean contaminants from the surface. Surface contaminants and paint interfere with corrosion removal procedures and make the operation more difficult.
- b. Protect adjacent components and parts from corrosion residue and possible damage that could be caused by the removal operation. Corrosion residue can cause additional corrosion and damage the surface finish of the surrounding area. An accidental slip of a corrosion removal tool can quickly result in additional damage.
- c. Prior to corrosion removal, determine the allowable limits from the system specific equipment manuals and/or technical orders. When removing corrosion from critical equipment structure, take the following steps:
  - (1) If allowable metal removal or damage limits will not be exceeded, remove corrosion completely. Metal loss due to corrosion damage is cumulative. Metal loss from prior corrosion removal operations and corrosion removal from areas on the opposite side of a part must be considered when assessing the degree of corrosion damage.

**TO 1-1-700**

- (2) If allowable damage limits will be exceeded, repair the damaged area or replace parts per procedures in system specific equipment repair manuals/technical orders. Coordinate any repair or part replacement not covered in these manuals/technical orders with the equipment SPM.

**11.3.1 Mechanical Methods.** There are various mechanical methods for removing corrosion from metal surfaces. The method used and the types of tools and equipment selected for the removal operation depend on the type of metal involved, the location and accessibility of the corroded area, the degree of damage, and the type of corrosion involved. It is important that the removal method, tools, and equipment selected be compatible with the metal surface. Compatibility involves two considerations: the mechanical effect of the equipment and tools on the surface, and the compatibility of metallic particles worn off the removal equipment and tools which might become embedded in the metal surface.



Corrosion removal accessories/tools, such as flap brushes or rotary files, shall be used on one type of metal only. For example, a flap brush used to remove corrosion from aluminum alloys shall not be used to remove corrosion from magnesium alloys or steel also.

**11.3.1.1 Mechanical Compatibility.** Mechanical compatibility refers to the selection of the right tools and equipment to prevent additional damage caused by the removal process. Often it is necessary to select a series of removal techniques involving the use of different grades or classes of equipment and material to effectively remove the corrosion products. The initial use of a rapid and coarse removal method followed by a slower and finer removal method produces a smooth metal surface finish (e.g., using a vacuum blaster first followed by using a fine abrasive cloth or paper to finish the job).

**11.3.1.2 Material Compatibility.** Material compatibility refers to using a medium for brushing, abrading, blasting, etc., which will not cause additional corrosion. Material compatibilities are assured by using like metals during corrosion removal operations (e.g., regular carbon steel wool shall never be used to remove corrosion from aluminum alloys as it will embed in the aluminum alloy surface and cause galvanic corrosion).

#### **11.4 NON-POWERED TOOLS AND MATERIALS.**

Below is a list of several non-powered tools and materials commonly used in the process of corrosion removal. For a

complete list of tools and materials procurement information refer to Appendixes A and B in TO 1-1-691.

**11.4.1 Abrasive Mats.** Abrasive mats are made from a nylon mesh material impregnated with various grades of aluminum oxide. Abrasive mats are available in 9 x 11 inch sheets under A-A-58054, Type I, Class 1, Grade A - Very Fine (280-400 grit), Grade B - Fine (180 grit), and Grade C - Medium (100-150 grit). These mats are used by hand to remove small areas of corrosion and/or paint where the use of powered tools would be impractical or prevented by the shape or accessibility of the area. Use Table 11-2 as a guide to relate abrasive mat materials to coated abrasive paper and/or cloth grit particle sizes.

**11.4.2 Abrasive Cloth.** Abrasive cloths with bonded aluminum oxide grit per A-A-1048 and silicon carbide grit per A-A-1200 are used for dry sanding of light to moderate corrosion products. They are available in 9 x 11 inch sheets and 2 or 3 inch wide x 150 foot long rolls in 240 grit (fine) and 320 grit (very fine) grades.

**11.4.3 Abrasive Paper.** Heavy paper with silicon carbide grit bonded to it per A-A-1047 is used for either wet or dry sanding to remove light to moderate corrosion. It is available in 9 x 11 inch sheets in 240 grit (Fine) and 320 grit (Very Fine) grades. Silicon carbide is usually more effective than aluminum oxide on harder metals such as low carbon and corrosion resistant steel alloys. Other abrasive paper and cloth with bonded emery or flint are available, but they suffer from poor efficiency and short working life.

**11.4.4 Wire Brushes.** Wire brushes are available with carbon steel, stainless steel (CRES), aluminum, and brass bristles and are used to remove heavy corrosion deposits and flaking paint that are not tightly bonded to the metal surface. Densely set, short, stiff bristles are most effective for rapid corrosion removal. The metallic bristles must be compatible with the metal surface being treated to prevent galvanic corrosion with stainless steel (CRES) being considered neutral and usable on all metals. Do not use brushes with a bristle wire gauge or diameter above 10.0 mils (0.010 inch), as severe gouging of the surface may occur and lead to stress risers that can cause stress and fatigue cracking. Remove the corrosion with a linear motion; do not cross-hatch as this will unnecessarily damage the surrounding surface area. After wire brushing, the surface areas must be polished with fine abrasive paper to remove and/or smooth out any gouges and scratches.

**11.4.5 Scrapers.** Scrapers are used primarily for the initial removal of heavy corrosion deposits such as flaking rust and exfoliation blisters, and are particularly effective in corners and crevices that cannot be reached with other equipment.

11.4.5.1 Scrapers may be locally manufactured from phenolic plastic, fiberglass, aluminum alloys, plain carbon steel, carbide-tipped carbon steel, or stainless steel (CRES). Plastic and fiberglass scrapers may be used on any type of metal surface but are of limited value due to their softness relative to a metal surface. Stainless steel (CRES) and carbide-tipped carbon steel scrapers may be used on any type of metal surface. Aluminum alloy scrapers may be used only on aluminum or magnesium alloy surfaces. Plain carbon steel scrapers may be used only on carbon steel surfaces.

11.4.5.2 Scrapers made from copper or brass alloys shall never be used on any structural metal surface as galvanic corrosion will result. Failure to use the correct metal scraper can also lead to galvanic corrosion after the part is returned to

service. Surface areas must receive further finishing after corrosion removal with scrapers due to the gouging action of scrapers and the difficulty in determining complete corrosion removal after their use.

### 11.5 POWER TOOLS AND MATERIALS.

Power tools are used to remove heavy corrosion from localized areas on metal surfaces or mild to severe corrosion over large surface areas. Their use results in saving time and money, but care must be exercised when using power tools. Application of excessive pressure can easily damage metal surfaces and cause internal metallurgical changes in the metal due to excessive heat buildup. Refer to Appendixes A and B in TO 1-1-691 for procurement information.

**Table 11-1. Recommended Powered Abrasives for Corrosion Removal**

Alloy	Flap Brush, Abrasive Wheels (1)	Abrasive Cloth/ Paper (2)	Abrasive Blasting Parameters		Other Tools
			Media (3)	Pressure (PSI)	
Aluminum alloys (Clad)	Aluminum oxide or silicon carbide	Aluminum oxide or silicon carbide	Glass beads (Sizes 10-13) or (AGB-15, 12, 9, or 6)	30-40 (4)	None
Aluminum alloys (Non-clad)	Aluminum oxide or silicon carbide	Aluminum oxide or silicon carbide	Glass beads (Sizes 10-13) or (AGB-15, 12, 9, or 6)	40-45 (4)	Rotary files (fine fluted)
Magnesium alloys	Aluminum oxide or silicon carbide	Aluminum oxide or silicon carbide	Glass beads (Sizes 10-13) or (AGB-15, 12, 9, or 6)	10-35 (4)	Rotary files (fine fluted)
Ferrous metals (other than stainless steel)	Aluminum oxide or silicon carbide	Aluminum oxide or silicon carbide	Aluminum oxide (Type 1, Grade A or B); Glass beads (sizes 10-13) or (AGB-15, 12, 9, or 6); Steel shot # S110 or S70; Steel grit #G200 or G325	40-50 (4) 40-50 (4)	Rotary files, Wire wheels (steel or stain- less steel)
Stainless steel and Nickel alloys	Aluminum oxide or silicon carbide	Aluminum oxide or silicon carbide	Glass beads (Sizes 10-13) or (AGB-15, 12, 9, or 6) (see Note 5)	40-50 (4)	Wire wheels (stainless steel) Rotary files (fine fluted)
Copper alloys	<b>DO NOT USE POWERED ABRASIVE METHODS DUE TO TOXICITY OF RESIDUE/ PARTICLES GIVEN OFF - IN PARTICULAR FROM BERYLLIUM-COPPER ALLOYS.</b>				

**Table 11-1. Recommended Powered Abrasives for Corrosion Removal - Continued**

Alloy	Flap Brush, Abrasive Wheels (1)	Abrasive Cloth/ Paper (2)	Abrasive Blasting Parameters		Other Tools
			Media (3)	Pressure (PSI)	
 <p>Powered abrasive operations on titanium alloys can generate severe sparking. Keep area clear of all ignitable substances when performing powered abrasive operations on titanium alloys.</p>					
Titanium alloys	Aluminum oxide or silicon carbide	Aluminum oxide or silicon carbide	Glass beads (Sizes 10- 13) or (AGB-15, 12, 9, or 6); Aluminum oxide (Type I, Grade A or B)	40-50 (4) 40-50 (4)	None
Plated and phos- phated surfaces	<b>DO NOT USE POWERED ABRASIVE METHODS DUE TO TOXICITY OF RESIDUE/PARTICLES GIVEN OFF FROM MANY TYPES OF PLATING AND PROBABLE SEVERE DAMAGE TO VERY THIN PLATING FILMS.</b>				

- (1) This includes Roloc™ type discs and inline and radial type Bristle Discs™.
- (2) This includes Roloc™ type discs.
- (3) Media specs: glass beads: SAE AMS 2431/6; Al. oxide: A-A-59316; Steel Shot: SAE J827; Steel Grit: SAE J1993.
- (4) Indicated pressure is for direct pressure equipment. For suction/venturi equipment, use 50% higher pressure.
- (5) Use only on heavily corroded parts prior to acid pickling and/or passivation.

**Table 11-2. Recommended Non-Powered Abrasives for Corrosion Removal**

Alloy	Non-woven Abrasive	Abrasive Cloth/ Paper	Metallic Wool	Brushes	Others
Aluminum alloys	Abrasive Mat	Aluminum oxide, Silicon carbide	Aluminum wool	Stainless steel, Aluminum	Pumice paste, Carbide-tipped scrapers
Magnesium alloys	Abrasive Mat	Aluminum oxide, Silicon carbide	None	Stainless steel, Aluminum	Pumice paste, Carbide-tipped scrapers
Ferrous metals (other than stainless steel)	Abrasive Mat	Aluminum oxide, Silicon carbide	Steel wool	Carbon steel, Stainless steel	Carbide-tipped scrapers
Stainless steel and Nickel alloys	None	Aluminum oxide, Silicon carbide	Stainless steel wool	Stainless steel, Aluminum	None
Copper alloys	None	Aluminum oxide (400 grit), Silicon carbide (400 grit)	Copper wool	Brass	None



**Table 11-2. Recommended Non-Powered Abrasives for Corrosion Removal - Continued**

Alloy	Non-woven Abrasive	Abrasive Cloth/ Paper	Metallic Wool	Brushes	Others
Titanium alloys	Abrasive Mat	Aluminum oxide, Silicon carbide	Stainless steel wool	Stainless steel, Aluminum	Pumice paste, Carbide-tipped scrapers
Cadmium or Zinc plated surfaces	Abrasive Mat	Aluminum oxide, Silicon carbide	None	None	None
Chromium, Nickel, Tin, or copper plated surfaces	Abrasive Mat	Aluminum oxide, Silicon carbide	None	Stainless steel, Aluminum	None
Phosphate surfaces	USE METHOD RECOMMENDED FOR BASE METAL				

**WARNING**

- Power tool operations can often generate toxic air-borne particles containing heavy metals, such as chromium (in the form of chromates), titanium, nickel, and beryllium, depending on the surface being treated. Eye protection, ventilation, and an adequate respirator for dust control are required.
- Do not use hands to probe for air leaks in power tools and their hoses as injury may result.
- Before using any powered equipment, remove any clothing such as ties and shirts with long loose sleeves as well as all rings and other jewelry which might become entangled in the equipment. Always wear proper personal protective equipment (PPE), such as goggles, face-shields, respirators, etc.
- Ensure that all electrical equipment is grounded. Corrosion removal with power tools is a very aggressive method which shall only be used when and where the extent of corrosion makes non-powered corrosion removal impractical. The indiscriminate use of power tools for corrosion removal can result in damage to protective surface finishes.

**11.5.1 Pneumatic Drill Motors.** Pneumatic drill motors are the preferred power tools for removing heavy corrosion or reworking large surface areas. The drill motor is normally used with wire brush wheels, rotary files, flap brushes, sanding pads, abrasive wheels, or buffing wheels. These drills are available in many shapes and sizes to satisfy almost any requirement. Check all pneumatic equipment air hoses for breaks or bulges in the coverings.

**11.5.1.1** Maximum chuck capacity of portable powered drills is usually 1/4 inch. Insert the tool shank into the drill and tighten chuck securely with the chuck key prior to use. When it is difficult or impossible to reach the work area with a straight drill, a flexible shaft or angle adapter can be used. The flexible shaft permits working around obstructions with a minimum of effort.

**11.5.1.2** To prevent the rotary file, abrasive wheel, flap brush, or sanding disc from digging into the metal, keep the tool off the metal when initially starting the drill motor. When the abrading stroke is finished, lift the tool from the metal before releasing the power to the motor.

**11.5.1.3** Holding the drill motor with both hands, apply moderate pressure while holding the rotary file, sanding disc, flap brush, or abrasive wheel against the work surface. When using the pneumatic tool as a sander, be sure to check the size and type of the abrasive disc. Ensure that the type of disc is compatible with the metal. Keep the sanding disc tilted to approximately a 10 degree angle so that only one side of the disc is in contact with the metal surface. If the entire disc surface is in contact with the surface, a “bucking” effect will occur. Excessive pressure will cause a “chattering” effect. Move the tool over the surface with slightly overlapping strokes. Do not grind, sand, or file in one area for any extended length of time without stopping and allowing the metal to cool. Excessive heating of the metal will alter its metallurgical structure.

**11.5.2 Pneumatic Sanders.** To prevent pneumatic sanders with oscillating heads from digging into the metal, start the sander before it touches the metal. When the sanding stroke is finished, lift the sander from the metal before pressing the stop switch. Do not lay the unit down with the motor running. For best results, apply moderate pressure while holding the sander against the work. Move the sander over the surface with parallel and slightly overlapping strokes. Move it as slowly as possible without causing overheating of the metal. Generally, the coverage rate should be about two square feet per minute.

## TO 1-1-700

11.6 3M CO. SCOTCH-BRITE™ FINISHING FLAP BRUSHES.

Do not use flap brushes down to within two inches of core (see Figure 11-2). Continued use beyond this limit may cause gouging due to loss of flexibility of fiber. When using flap brushes, apply minimal pressure to the tool so that a minimum amount of metal will be removed. Excessive pressure on flap brushes will cause paint at the edge of the area being worked to melt, gum up, and streak onto the work area. Do not use on non-metallic surfaces.

**11.6.1 Flap Brushes.** Flap brushes are made of non-woven, nylon webbing impregnated with aluminum oxide grit. The brushes are very effective for removing mild surface corrosion and prepping surfaces. It can also be used for mechanical removal and feathering of paint systems. The brushes are comprised of a series of flaps bonded to a cardboard core and attached to a mandrel. Each flap impacts the surface as the brush spins. When used correctly, the brushes will lead to minimal metal removal. The flap brush and mandrel (refer to Figure 11-1) shall be assembled so that the arrow painted on the brush is facing the operator and points in the direction of rotation (clockwise). To achieve maximum effectiveness, use at the specified RPM, and do not exceed the maximum RPM rating specified on the brush to prevent disintegration during use and either damage to equipment or injury to personnel.

**11.6.2 Abrasive Flap Wheels.** Abrasive flap wheels come in various types. One type is made of paper flaps impregnated with aluminum oxide abrasive and mounted on a spindle (refer to Figure 11-2). Another type is made from a resin reinforced nylon mesh impregnated with aluminum oxide abrasive in a convoluted flap form per A-A-59292, Class 1 or a unitized, rigid, laminated form per A-A-59292, Class 2, both of which are mounted on arbors. Depending on grit size, these wheels can be used to remove medium to severe corrosion from thick materials, but caution must be used to minimize the amount of metal removal. For the most effective use of this equipment, use at the specified RPM and never exceed the maximum RPM rating specified on the wheel to prevent disintegration of the wheel during use and either damage to equipment or injury to personnel.

11.7 ABRASIVE CLOTH AND PAPER.

Aluminum oxide and silicon carbide cloth and paper can be used with sanders and drill motors by cutting suitable pieces from stock or using precut discs mounted on pad type holders.

11.8 POWERED WIRE BRUSHES.

Unless authorized and directed by the cognizant equipment SPM, rotary wire brushes are not authorized for corrosion removal on any metals except low strength carbon steels. They can severely damage softer metal alloys such as aluminum and magnesium by leaving deep gouges in them and cause fatigue problems in high strength steel and aluminum alloys due to the stress risers created by the deep scratches/gouges they leave on the surface.

Powered wire brushes are available with various types of wire (straight, twisted, or crimped), various lengths of wire (short, medium, or long), and various wire densities (light, medium, or heavy). Different actions can be obtained by varying wire type, trim length, and density.

11.9 ROTARY FILES.

Improper use of rotary files can rapidly damage aluminum structures by creating thin spots that exceed established damage limits. Their use is authorized only for removal of severe intergranular exfoliation corrosion by qualified structural repair technicians. Do not use rotary files to remove corrosion from installed fasteners.

Since they provide one of the fastest ways to remove corrosion and underlying metal, rotary files should only be handled by an experienced structural repair technician. This tool is a tungsten carbide cylinder or cone into which cutting edges have been machined. When installed in the chuck of a pneumatic drill, rapid metal removal can be achieved.

11.10 3M CO. ROLOC™ DISC AND RADIAL DISC ABRASIVES.

These tools are available in various grits and diameters to cover all corrosion removal requirements from initial grind out to final finishing/smoothing of the grind-out area. To achieve maximum effectiveness with these discs, use at the specified RPM, and never exceed the maximum RPM rating specified on the disc to prevent disintegration of the disc during use and either damage to equipment or injury to personnel.

**11.10.1 Roloc™ Discs.** Roloc Discs consist of a spindle that screws into a disc pad that receives a screw on type paper

coated abrasive disc, a Scotch-Brite™ nylon mesh abrasive disc, or a plastic Bristle Disc™ abrasive. These disc assemblies are mounted to either a straight or right angle type pneumatic drill to remove corrosion from all types of readily accessible metal surfaces.

11.10.2 **Radial Type Plastic Bristle Disc™.** This type is similar to a flap wheel and is mounted to an arbor either by itself or in multiples with the assembly being installed in a straight type pneumatic drill to remove corrosion from all types of metal surfaces, particularly in bores and recessed areas.

### 11.11 ABRASIVE BLASTING.

#### WARNING

Abrasive blasting operations create airborne particles which may be hazardous to the skin, eyes, and respiratory tract. A hood, gloves with gauntlets and adequate ventilation are required.

In abrasive blasting, abrasive media is propelled toward the work piece either with air pressure (conventional or vacuum blasting) or with water (wet blasting).

11.11.1 **Conventional Equipment.** Two types of equipment are used to propel dry abrasives: direct pressure feed and suction/venturi feed. In direct pressure equipment, the abrasive holding tank is a pressure vessel from which abrasive media is forced, through a metering device, into the pressurized blast line to the blast nozzle. In suction/venture feed equipment, the

abrasive holding tank is un-pressurized and provides media, through a metering device, into a passing air stream which then propels it through the blast hose to the blast nozzle.

11.11.1.1 Small blast cabinets known as glove boxes (see Figure 5-6, A of TO 1-1-691) are built to accommodate small parts and have a recycle system which removes dust and light particle contaminants such as paint chips or corrosion products. Blasting rooms, designed for large components, use a recycling and ventilating system. The operator works within the room, using a blast gun.

#### NOTE

Suction/venturi feed equipment requires higher nozzle pressure than direct pressure equipment to obtain the required abrasive action. Pressures given in Table 5-3 of TO 1-1-691 are for direct pressure equipment. As a general rule, increase the nozzle pressure by 50 percent when using suction/venturi feed equipment.

11.11.1.2 Vacu-blasters have an abrasive hopper, a reclaiming, a dust collector, a vacuum pump, and a blast gun which contains both a blast nozzle and a vacuum duct surrounding the nozzle for recovery of the media (see Figure 5-6, B of TO 1-1-691). Use this equipment only on flat or slightly curved surfaces to ensure that all media rebounding from the surface is collected by the vacuum duct surrounding the blast nozzle. Refer to TO 35-1-3, the equipment operator's manual, and systems specific maintenance manuals for the equipment being repaired for further information on the authorization and use of these machines.

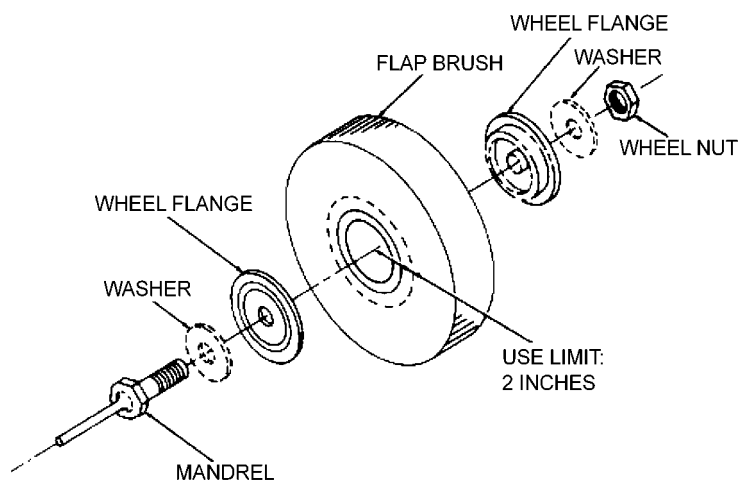

Figure 11-1. 3M Co. Scotch-Brite™ Flap Brush and Mandrel



Figure 11-2. Abrasive Flap Wheels with Spindle Mount

### 11.11.2 Control of Mechanical Damage During Abrasive Blasting.

#### CAUTION

#### WARNING

- Use extreme care to ensure that blast media does not contaminate hydraulic, fuel, oil, or coolant systems. Blockages in critical components caused by abrasive media particles can result operational failures and severe damage to equipment.
- Finely divided dried particles of many materials (metallic, organic, and inorganic) can form explosive mixtures with air resulting in dust explosion hazards. Use extreme care when dry abrasive blasting magnesium and titanium alloys, and provide adequate ventilation to prevent formation of explosive dust mixtures during all abrasive blasting operations.
- Abrasive blasting operations shall not subject these surfaces to severe abrasive action.
- Dry abrasive blasting of titanium alloys and high strength steel will create sparking. Ensure that the abrasive blasting area is free of all flammable vapors and liquids.

- Protect areas adjacent to abrasive blasting corrosion removal operations from chips, dust, and other debris which could produce dissimilar metal/galvanic corrosion on previously corrosion free surfaces.
- Use only those abrasive blasting media recommended in Table 11-1 and do not reuse this media on a different type metal to prevent dissimilar metal particles from becoming embedded in surfaces and generating rapid galvanic corrosion.
- Do not use abrasive blasting to remove corrosion from soft plated surfaces (zinc, cadmium, etc.). Soft plating is easily damaged or removed by mechanical methods.

**11.11.3 Abrasive Blasting Corrosion Removal.** Before beginning abrasive blasting operations, ensure that all safety precautions listed in the warnings and cautions are fully observed. Failure to comply with these precautions may result in harm to personnel and equipment.

### 11.11.3.1 Personal Protection.

#### WARNING

- Many materials such as copper alloys, especially beryllium-copper (see Chapter 7 of TO 1-1-691); cadmium plate; chromate conversion coatings; paints containing chromates; lead; barium; strontium; and chemicals used for corrosion removal are toxic. Use approved respirators, eye protection, and skin protection. Take proper safety precautions to avoid inhalation or ingestion of chemical fumes or liquids and dust from corrosion products during abrasive blasting corrosion removal. Wash hands thoroughly before eating or smoking.
- All powered abrasive blasting corrosion removal procedures create airborne particles. Respirators and eye protection and adequate ventilation are required.
- It is essential that all blasting media and other residue be completely removed after abrasive blasting operations. The blasting media can be very slippery and can cause dangerous falls.
- Operators shall be adequately protected with complete face and head covering equipment, and provided with pure breathing air per requirements of AFOSH Standard 91-501 for all abrasive blasting operations.

11.11.3.2 Abrasive Blasting Procedures. Accomplish abrasive blasting operations using the procedures outlined in Chapter 5 of TO 1-1-691.

#### NOTE

- Refer to the individual system specific equipment maintenance manuals for limits on metal removal. Do not exceed these limits without engineering approval from the equipment SPM.
- Abrasive blasting will not remove intergranular and/or exfoliation corrosion from aluminum alloys.

- Abrasive blasting shall be used on stainless steel (CRES) and nickel alloy parts only to remove severe/heavy corrosion and prior to acid pickling and/or passivation.

### 11.12 NON-POWERED AND POWERED TOOL CORROSION REMOVAL.

The following WARNINGS and CAUTIONS shall be observed during corrosion removal operations:

#### 11.12.1 Personal Protection.

#### WARNING

- Many materials such as copper alloys, especially beryllium-copper (see Chapter 7 of TO 1-1-691); cadmium plate; chromate conversion coatings; paints containing chromates; lead; barium; strontium; and chemicals used for corrosion removal are toxic. Use approved respirators, eye protection, and skin protection. Take proper safety precautions to avoid inhalation or ingestion of chemical fumes or liquids and dust from corrosion products during corrosion removal. Wash hands thoroughly before eating or smoking.
- All powered mechanical corrosion removal procedures create airborne particles. Respirators and eye protection and adequate ventilation are required.
- Wear leather gloves when using metallic wools to prevent hand injuries.
- Do not use abrasive flap brushes, wheels, discs or wire brushes above their authorized RPM rating. These tools can fly apart, causing serious injury.
- Exercise caution when using sharp or pointed tools to prevent injury.

## TO 1-1-700

11.12.2 Mechanical Damage.

- Do not use rotary files to remove corrosion from installed fasteners.
- Use only non-powered abrasive paper, cloth, or mat, powered flap brushes or wheels, or abrasive blasting to remove corrosion from high strength steels. Other power tools can cause local overheating and/or formation of notches which can generate fatigue or stress corrosion cracking failures.
- Do not use flap brushes down to within two inches from the center of the hub. Continued use beyond this limit may cause gouging due to loss of flexibility of the fiber. Follow direction of rotation, as indicated by arrow imprinted on side surface of the core.
- Excessive pressure on flap brushes will cause polyurethane paint to melt, gum up, and streak around the area being worked
- Protect areas adjacent to corrosion removal operations from chips, dust, and other debris which could produce dissimilar metal corrosion on previously un-corroded surfaces.
- Use only those materials recommended in Tables 11-1 and 11-2 to prevent dissimilar metal particles from becoming embedded in surfaces and generating rapid galvanic corrosion.
- Be careful when removing corrosion from soft plated surfaces (zinc, cadmium, etc.). Soft plating is easily damaged or removed by mechanical methods.

11.12.3 Non-Powered Tool Corrosion Removal Procedures. Remove corrosion by abrading the corroded surface with hand held tools or abrasives. This method is normally used to remove surface corrosion and other forms of mild to moderate corrosion by scraping or wearing away the corrosion products along with a minor amount of base metal. The basic steps in this procedure can be found in Chapter 5 of TO 1-1-691

11.12.4 Powered Tool Corrosion Removal. Powered tool corrosion removal is generally done using pneumatic drills with flap brush, rotary file, sanding pad or abrasive wheel attachments. This method is normally used to remove heavy

corrosion by wearing away the corrosion products. Part of the base metal is abraded away with the corrosion products using this procedure. The basic steps in corrosion removal can be found in Chapter 5 of TO 1-1-691

11.13 CHEMICAL CORROSION REMOVAL.

The following paragraphs discuss chemical removal procedures for use on equipment, parts/components, and assemblies. Each type of metal alloy requires specific chemicals for removal of the different types of corrosion that are encountered on the metal alloy. The authorized chemical corrosion removal materials and procedures for their usage for each of the various metal alloys used on Air Force equipment is discussed separately for each metal alloy. Refer to Appendixes A and B in TO 1-1-691 for procurement information.

11.13.1 Aluminum Alloys. These paragraphs outline chemical corrosion removal procedures for aluminum alloy parts and assemblies of C-E-M equipment. Table 11-3 provides procedures for chemical removal of specific types of corrosion from aluminum alloys.

11.13.1.1 Preparation. Before starting chemical removal of corrosion products, perform the following procedures:

- a. Clean all dirt, grease, oil, and other contamination from surfaces to be worked in accordance with Chapter 7 of this manual.
- b. Inspect the equipment to determine which area(s) are and should be treated with a chemical corrosion removal compound.
- c. Mask all lap joints, hinges, faying surfaces, access doors, air scoops, and other openings that would allow the corrosion removal compound to enter interior areas or crevices, or contact unprotected magnesium, steel, and cadmium plated parts. Mask with MIL-PRF-131, Class 1 Water and Vapor Proof Barrier Material (plastic side toward the surface) and SAE AMS-T-23397, Type II (MIL-T-23397, Type II) Masking Tape. 3M Co. part No. 425 tape is the most effective tape for extensive operations, such as chemical corrosion removal and surface preparation on large structures such as aircraft exteriors during depot repaint operations.



SAE AMS-1640 (MIL-C-38334), CORROSION REMOVING COMPOUND

60





MIL-DTL-81706 (ALODINE), COATING, CHEMICAL  
CONVERSION

23



SERMCO PASA-JELL 102, CHEMICAL CONVERSION  
REMOVAL FOR ALUMINUM ALLOYS

56

**11.13.1.2 Chemical Corrosion Removal Materials for Aluminum Alloys.** SAE AMS-1640 (MIL-C-38334, Type I) Corrosion Removal Compound for Aircraft Surfaces, is the authorized general chemical remover for removing corrosion products from aluminum alloys, in particular on larger areas. Limited area corrosion removal can also be accomplished by using MIL-DTL-81706 (MIL-C-81706), Class 1A Chemical Conversion Coating Solution or Semco® Pasa-Jell 102 gel type aluminum corrosion remover in conjunction with A-A-58054, Type I, Grade B or C Abrasive Mats. See Table 11-3 for typical chemical corrosion removal procedures.



SAE AMS-1640 (MIL-C-38334), CORROSION REMOVING  
COMPOUND

60



- Protect all magnesium surfaces from contact with SAE AMS-1640 (MIL-C-38334) corrosion removal compound and treat later, as prescribed in this manual. Steel and cadmium plated parts should also be protected from this compound, but protection of all steel and cadmium plated steel fastener heads in large structures is impractical and need not be done.
- Do not allow these chemical corrosion removers to contact high strength steel. Hydrogen embrittlement may occur and cause a catastrophic failure.

**11.13.1.2.1 SAE AMS-1640 (MIL-C-38334, Type I) Corrosion Removing Compound Uses and Mixing Instructions.** SAE AMS-1640 (MIL-C-38334, Type I) is used as a general chemical corrosion remover to remove surface and pitting corrosion products from aluminum alloy surfaces. It is

not Liquid Oxygen (LOX) compatible. This material is a liquid concentrate material which shall be mixed with an equal volume of tap water before use; further dilution renders it ineffective. This material has a shelf life of one year from the date of manufacture; discard any of the material which has reached or exceeded its shelf life.

**11.13.1.2.1.1 Application and Use of SAE AMS-1640 (MIL-C-38334, Type I).** The procedure for application and use of SAE AMS-1640 (MIL-C-38334, Type I) materials can be found in Chapter 5 of TO 1-1-691. After each solution application and rinse, examine the area being worked, aided with a 10X magnifier for pitting, to determine if all corrosion products have been removed. If not, repeat this process a maximum of three more times. If corrosion products remain after the fourth application of this chemical remover, use an appropriate mechanical method described in this chapter to remove the remaining corrosion products.



SEMCO PASA-JELL 102, CHEMICAL CORROSION  
REMOVAL FOR ALUMINUM ALLOYS

56

**WARNING**

Do not use aluminum or any type of steel wool to apply or agitate Semco® Pasa-Jell 102 or fire will result.



Excessive use of abrasive materials and Semco® Pasa-Jell 102 can cause removal of protective cladding (Alclad) and/or excessive metal removal.

**11.13.1.2.2 Uses for Semco® Pasa-Jell 102.** This material is a gel type chemical corrosion remover for use on aluminum alloys in limited areas, in particular where LOX compatibility is required, to remove pitting and surface corrosion or etching/oxidation. Pasa-Jell 102 is a relatively strong acid mixture that can be detrimental to equipment or components if improperly used. Therefore, it shall be used only in small areas and primarily where LOX compatibility is an essential requirement. Personnel must be properly trained and qualified to use this material for corrosion removal. The procedure for application and use of Semco® Pasa-Jell 102 material can be found in Chapter 5 of TO 1-1-691.

## TO 1-1-700



MIL-DTL-81706 (ALODINE), COATING, CHEMICAL CONVERSION

23

**NOTE**

MIL-DTL-81706 (MIL-C-81706)/MIL-DTL-5541, Class 1A Chemical Chromate Conversion Coating, shall be applied immediately after the final rinse when corrosion removal is the last process of a rework operation, or when the item or area will be painted.

11.13.1.2.3 MIL-DTL-81706 (MIL-C-81706), Class 1A, Uses and Mixing Instructions. Chemical chromate conversion coating solutions are used for limited area corrosion removal from aluminum alloy surfaces while simultaneously applying a chemical chromate conversion coating.

- a. This can be accomplished by using a MIL-DTL-81706 (MIL-C-81706), Class 1A solution in conjunction with an A-A-58054, Type I, Grade C Abrasive Mat. This material helps to clean an area by oxidizing all organic soils on the aluminum alloy surface, while the abrasive mat acts to remove the corrosion products, and then the solution forms a chemical chromate conversion coating film on the aluminum alloy surface. If organic soils are present, they will turn green upon application of the solution.
- b. The green residue and the solution contaminated with the residue should be wiped from the surface and discarded. Mix the MIL-DTL-81706, Class 1A solution in accordance with the manufacturer's instructions and Section II of Chapter 5 in TO 1-1-691.
- c. It is recommended that the technician practice on some condemned components or parts prior to using this material on serviceable aircraft, missile, or equipment aluminum alloy parts.

**Table 11-3. Typical Chemical Corrosion Removal Procedures for Aluminum Alloy Parts and Assemblies**

Type of Corrosion	Step 1 Corrosion Removal	Step 2 Surface Treatment (When applicable)	Step 3 Final Protective Paint Finish (When applicable)
Light or heavy pitting or etching of aluminum alloys (clad)	Remove corrosion with SAE AMS-1640 (MIL- C-38334, Type I) per Chapter 5 in TO 1-1-691	MIL-DTL-81706/MIL-DTL-5541, Class 1A per Section II of Chapter 5 in TO 1-1-691	See TO 1-1-8 and equipment system specific maintenance manuals for paint system
Light or heavy pitting or etching of aluminum alloys (non-clad)	Remove corrosion with SAE AMS-1640 (MIL- C-38334, Type I) per Chapter 5 in TO 1-1-691 followed by appropriate mechanical methods in this chapter if necessary	As above	As above
Intergranular or exfoliation corrosion of aluminum alloys	Not applicable. Remove corrosion by appropriate mechanical methods in this chapter	As above	As above
Light or heavy pitting or etching on small aluminum alloy parts which can be removed for treatment	Remove corrosion and/or oxide film by immersion in a SAE AMS-1640 (MIL-C-38334, Type I) prepared per Chapter 5 in TO 1-1-691	Immersion in MIL-DTL-81706, Class 1A solution per Section II of Chapter 5 in TO 1-1-691	As above

11.13.1.2.3.1 Application of MIL-DTL-81706 (MIL-C-81706), Class 1A Solutions for Corrosion Removal. The procedures for application of these materials for corrosion removal are the same as those cited in Section II of Chapter 5 in TO 1-1-691 for the standard chemical chromate conversion coating solutions, except as follows:

- a. The small area requiring corrosion removal and surface treatment can be cleaned with the chemical chromate conversion coating solution instead of cleaning with cleaning solutions, rinsing, and drying before application of the solution. Thoroughly wet or flood the area being worked with the solution and keep it wet with solution until all phases of the process are completed and the final film is formed to prevent streaking and/or powdering on the surface. Lightly abrade the surface while wet with the solution using a A-A-58054, Type I, Grade C Abrasive Mat.
- b. If the solution turns green, continue to abrade the entire area until it is completely cleaned, and then wipe all dirty solution from the surface with a sponge. This should leave a bright, shiny surface. If dark spots or lines are seen in the area, this indicates the presence of residual spots of moderate to severe corrosion.
- c. Reapply the solution and vigorously agitate the wetted area with an abrasive mat as before. If the corrosion is not completely removed after this second application of solution, remove the remaining corrosion using an appropriate mechanical method in this chapter.



MIL-DTL-81706 (ALODINE), COATING, CHEMICAL CONVERSION

23

- d. After corrosion removal is complete and the dirty solution is removed, reapply MIL-DTL-81706, Class 1A to form a MIL-DTL-5541, Class 1A film on the surface and allow the film to form in accordance with procedures in Section II of Chapter 5 in TO 1-1-691.

11.13.2 Magnesium Alloys. The following paragraphs outline chemical corrosion removal procedures for the removal of corrosion from magnesium alloy parts. Table 11-4 provides procedures for the removal of specific types of corrosion.

#### NOTE

Removable parts can be treated more effectively by applying one of the electro-deposition conversion coatings, such as Type IV or VII of SAE AMS-M-3171 (MIL-M-3171) after corrosion removal instead of the brush on Type VI coating specified for coating repair after corrosion removal from small areas discussed here.

11.13.2.1 Preparation. Before starting chemical removal of corrosion products remove paint from the area per TO 1-1-8 and clean all grease, oil, and other contamination from surfaces to be worked in accordance with Chapter 7 of this manual. If practical, use one of the procedures for cleaning magnesium alloys by immersion, spray, or vapor blast included in SAE AMS-M-3171 (MIL-M-3171).



A-A-55827, CHROMIUM TRIOXIDE

2

#### WARNING

Do not allow rags, brushes, abrasive mats, or any other item soaked with A-A-55827 chromic acid or the chromic acid pickle solution prepared with it to come in contact with any organic solvent (MEK, acetone, paint thinner, A-A-59601/MIL-PRF-680 dry cleaning solvent, etc.) or fire will result.



Do not allow excessive amounts of anions such as chlorides, sulfates, or fluorides to build up in the solution; they tend to coat or etch the metal surface rather than removing corrosion products. Do not reuse old solutions; prepare fresh solutions for each separate removal operation.

11.13.2.2 Chemical Corrosion Removal Materials for Magnesium Alloys. Chromic acid pickle solution which is a mixture of A-A-55827, Chromium Trioxide, in water may be used to remove surface oxidation and light corrosion from magnesium alloy surfaces. The procedure for application and use of chrome pickle solution, a mixture of A-A-55827 Chromium Trioxide in water, can be found in Chapter 5 of TO 1-1-691.

#### NOTE

Chromic acid pickle is not adequate for removal of deep pitting, heavy corrosion, sand or other blast media residue, or the effects of blasting which will require use of one of the mechanical methods described in this chapter. If properly used, this chemical method removes much less metal causing much less reduction of sectional thickness than mechanical methods, but it shall not be used on parts containing copper or steel inserts unless they are completely masked off.

## TO 1-1-700

11.13.2.3 Application of Organic Coatings. Reapply the organic coating system specified in the appropriate system specific maintenance manual and/or engineering drawing for the piece of equipment and TO 35-1-3 for support equipment (SE) using TO 1-1-8 for application procedures.

**NOTE**

Apply the paint within 48 hours after application of the pretreatment coating. Reapply the pretreatment coating in accordance with Section II of Chapter 5 in TO 1-1-691 if more than 48 hours have elapsed since application of the pretreatment coating.

11.13.3 Ferrous Metal (Steel) Alloys Other Than Stainless Steels (CRES). These paragraphs outline chemical corrosion removal procedures for treating ferrous metal alloy parts and equipment assemblies. Use of chemical corrosion removers on steels is recommended only for areas where there is no danger of entrapping the chemicals in crevices and/or recesses. Table 5-7 in Chapter 5 of TO 1-1-691 provides procedures for the removal of specific types of corrosion.

11.13.3.1 Preparation. Before starting chemical removal of corrosion products, remove paint from the area per TO 1-1-8 and clean all heavy deposits of grease, oil, and other contaminants from the surfaces to be worked in accordance with Chapter 3 of TO 1-1-691.

**Table 11-4. Typical Chemical Corrosion Removal Procedures for Magnesium Alloys**

Type of Corrosion	Step 1 Corrosion Removal	Step 2 Surface Treatment	Step 3 Protective Finish
Light pitting or surface oxidation/etching	Remove corrosion with chromic acid pickle solution per Chapter 5 in TO 1-1-691.	SAE AMS-M-3171 (MIL-M-3171), Type VI per Section II of Chapter 5 in TO 1-1-691	Approved paint system per paragraph 11.13.2.3
Heavy pitting or etching	Not applicable. Remove corrosion by an appropriate mechanical method in this chapter.	As above	As above
Intergranular or exfoliation	Not applicable. Remove corrosion by an appropriate mechanical method in this chapter.	As above	As above
Corrosion on small parts which can be removed for treatment	Remove corrosion according to SAE AMS-M-3171 (MIL-M-3171).	As above	As above



MIL-C-10578, COMPOUND, CORROSION REMOVING AND METAL CONDITIONING 20



A-A-59260 (MIL-C-14460, TYPE I), CORROSION REMOVING COMPOUND 6

11.13.3.2 Chemical Corrosion Removing Materials for Ferrous Metal Alloys Other Than Stainless Steels (CRES). Chemical corrosion/rust removers for steels are of two types; the MIL-C-10578 acid type and the A-A-59260 (MIL-C-14460) alkaline type.

11.13.3.2.1 MIL-C-10578 Corrosion Removing and Metal Conditioning Compound (Phosphoric Acid Base). MIL-C-10578 covers six separate types of phosphoric acid based corrosion/rust removing compounds used to remove corrosion/rust from ferrous metal surfaces. The following types are available:

11.13.3.2.1.1 Type I (Wash-Off) and II (Wipe-Off). Type I and II materials are suitable as rust removers for ferrous alloy metal parts. They may also be used as metal conditioners for ferrous and nonferrous (zinc galvanized, cadmium, brass, and relatively pure aluminum or alclad) metals prior to the primer and paint application and/or as a corrosion preventive to provide minor corrosion protection to these metals in an unpainted condition. Remove very heavy rust incrustations using an appropriate mechanical method listed in this chapter and heavy grease, oil, and other contamination per Chapter 7 of this manual as directed before application of these materials.

- a. Type I is a little more efficient in removing rust and grease than Type II. Type I materials are applied by

either spray, dip, flow-on, brush, rag, or sponge and are always rinsed off with water, preferably hot.

- b. Type II materials are applied by either brush, rag, or sponge and do not have to be rinsed off with water, but are wiped off with clean, damp rags followed by wiping with clean, dry rags prior to painting. Type II materials leave a light, gray-white coating/film on the surface that acts as a pretreatment for painting.

11.13.3.2.1.2 Type III (Inhibited). Type III materials are intended for corrosion/rust removal from chromium plated ferrous alloy surfaces and those bare ferrous alloy surfaces requiring very close dimensional tolerances. Remove very heavy rust incrustations by an appropriate mechanical method in this chapter, and heavy grease, oil, and contamination per Chapter 7 of this manual as directed by paragraph 11.13.3.1 or by vapor degreasing before application of these materials.

- a. Type III materials are applied by, spray, dip, flow-on, brush, or by full immersion in a tank containing the material. Parts are left in the solution tank or the solution is left on the surface of the part until the rust is dissolved or loosened sufficiently to permit easy removal, and then the residue is rinsed off the surface with fresh, tap water, preferably hot, and the part is dried. It is then ready for application of the required corrosion preventive treatment or paint system application.

11.13.3.2.1.3 Type IV (Non-Foaming). Type IV materials are very similar to Type I, except that non-foaming detergents are included in the mixture. It is intended for use in pressurized spray systems at temperatures up to 150 °F (66 °C) maximum, after which it is rinsed off with fresh, tap water.

11.13.3.2.1.4 Type V (Immersion Tank). Type V materials are also very similar to Type I, except no grease removing solvents are used in these materials, so they are only suitable for use on surfaces from which all grease, oil, and contamination have been completely removed by cleaning per Chapter 7 of this manual as directed by paragraph 11.13.3.1. It is intended for use in immersion tanks either at ambient temperatures or at temperatures up to 140 °F (60 °C) maximum.

11.13.3.2.1.5 Type VI (Brush, Spray, or Dip). Type VI materials are surface pretreatments and/or rust converters for application on either newly sand blasted or corroded/rusty steel surfaces by spray, brush, or dipping. All old grease, oil, and dirt must be removed as well as all loose and scaly rust before applying these materials. After application, they are allowed to dwell on the surface for a minimum of six hours to form a pretreatment coating on corrosion free ferrous alloys or to convert the rust on a corroded ferrous surface to a protective, pretreatment film. After a dwell time of six hours, the

excess materials are rinsed off, the surface is allowed to air dry, and then the surface can be primed and painted or treated with a CPC.



MIL-C-10578, COMPOUND, CORROSION REMOVING AND METAL CONDITIONING

20



- High strength steel parts, those heat-treated above Rockwell C40 (180,000 PSI) tensile strength, are subject to hydrogen embrittlement when exposed to acids, therefore, use of acid rust/corrosion removers on these parts is prohibited.
- Do not use acidic rust/corrosion removers if there is a danger of entrapping the materials in crevices or recesses, as they can cause corrosion in these areas.

11.13.3.2.1.6 Application and Use of MIL-C-10578 Corrosion Removing Compounds. The directions for application and use of types I through type VI materials can be found in Chapter 5 of TO 1-1-691.



A-A-59260 (MIL-C-14460, TYPE I), CORROSION REMOVING COMPOUND

6

11.13.3.2.2 A-A-59260 (MIL-C-14460, Type I) Corrosion Removing Compound, Sodium Hydroxide Base; for Electrolytic or Immersion Application. This is a highly alkaline chemical corrosion/rust removing compound suitable for rust removal by immersion of the parts in the solution. It doesn't cause dimensional change of critical or machined surfaces, and it is safe to use on high strength steels as it will not cause hydrogen embrittlement. It can be used on small parts with or without paint, grease, or other surface coatings. The directions for application and use of these materials can be found in Chapter 5 of TO 1-1-691.

11.13.4 Stainless Steel (CRES) and Nickel Based Alloys. The following paragraphs outline chemical corrosion removal procedures for stainless steel (CRES) and nickel based alloy parts and assemblies. Table 11-5 provides procedures for removing specific types of corrosion. Chemical corrosion removal is recommended for severely corroded areas

**TO 1-1-700**

only when there is no danger of entrapping chemicals in recesses, cavities, or joint areas or damaging surrounding metals and plating. Use these chemical procedures on installed components which are not readily removable. When internal corrosion is evident, affected components shall be removed and processed through an overhaul facility in accordance with system specific maintenance manuals for the specific piece of equipment.

11.13.4.1 **Preparation.** If the corroded area is contaminated with grease, oil, dirt, or any other foreign material, clean the area per Chapter 7 of this manual.

- a. Protect adjacent unaffected areas not being treated by masking to prevent damaging them with the chemicals used.



■ MIL-PRF-680 AND A-A-59601, SOLVENT, DEGREASING, TYPE II AND III 45

**WARNING**

When using metallic wools, wear leather gloves and exercise care to prevent injury to hands and fingers.



- Take care to prevent solvents from splashing or running because they can damage paints and elastomers (e.g., rubbers, plastics).
  - Take care to protect surrounding unaffected areas next to the area being treated by preventing leakage of chemicals into recesses or inaccessible areas in the structure which can cause additional damage from corrosion attack.
- b. Remove all loose corrosion by abrading the surface with either A-A-1043, Type IV, Class 1 Stainless Steel Wool, 240 grit ANSI B74.18 (A-A-1047) Silicon Carbide Abrasive Paper or ANSI B74.18 (A-A-1200) Silicon Carbide Abrasive Cloth, 240 grit ANSI B74.18 (A-A-1048) Aluminum Oxide Abrasive Paper or Cloth, or A-A-58054, Type I, Grade C Abrasive Mat. Remove all loose particles by wiping the surface with a clean cloth dampened with A-A-59601 or MIL-PRF-680, Type II or III dry cleaning and degreasing solvent.



Table 11-5. Typical Chemical Corrosion Removal Procedures for Stainless Steel (CRES) and Nickel Based Alloys

Type of Corrosion	Step 1 Corrosion Removal	Step 2 Surface Treatment	Step 3 Protective Finish
	 <p data-bbox="532 470 1211 541">SEMCO PASA-JELL 101, CHEMICAL CORROSION REMOVAL FOR STAINLESS STEEL (CRES) AND NICKEL BASED ALLOYS</p>		64
<p data-bbox="175 751 521 1031">Light to heavy corrosion/rust to include pitting on installed parts where liquid chemical corrosion/rust removal is impractical because of location involving liquid oxygen (LOX) storage or gaseous oxygen transfer equipment, complexity of the structure, or rinsing difficulties.</p> <p data-bbox="175 1188 521 1272">As above, when liquid chemical corrosion/rust removal is practical.</p> <p data-bbox="175 1367 521 1451">Light to heavy corrosion to include pitting on parts which can be removed for processing.</p>	<p data-bbox="548 751 862 999">Remove very heavy corrosion/rust first with stainless steel wool or wire brush, rotary file, or other mechanical means in this chapter followed by application of Semco® Pasa-Jell 101 (see paragraph 11.13.4.2.1).</p> <p data-bbox="548 1188 862 1335">Remove very heavy corrosion/rust as above first followed by application of MIL-C-10578, Type III solution (see paragraph 11.13.4.2.2.1).</p> <p data-bbox="548 1367 862 1545">Remove very heavy corrosion/rust as above first followed by immersion in the nitric-hydrofluoric acid pickling solution (see paragraph 11.13.4.2.3.1</p>	<p data-bbox="898 751 959 779">None</p> <p data-bbox="898 1188 959 1215">None</p> <p data-bbox="898 1367 1219 1545">Passivate per SAE AMS-QQ-P-35 (QQ-P-35), Type II, VI, VII, or VIII as applicable to the type of stainless steel (CRES) alloy being treated (see Chapter 5 in TO 1-1-691)</p>	<p data-bbox="1255 751 1544 1157">Normally not required; but sometimes for camouflage purposes, extreme corrosive conditions, or elimination of dissimilar metal contact it may be required. Apply the system specified in the equipment system specific maintenance manual and/or engineering drawing or TO 35-1-3 for SE using procedures in TO 1-1-8</p> <p data-bbox="1255 1188 1349 1215">As above</p> <p data-bbox="1255 1367 1349 1394">As above</p>

## TO 1-1-700



SEMCO PASA-JELL 101, CHEMICAL CORROSION  
REMOVAL FOR STAINLESS STEEL (CRES) AND  
NICKEL BASED ALLOYS 64



MIL-C-10578, COMPOUND, CORROSION REMOVING  
AND METAL CONDITIONING 20



A-A-59105 (O-N-350), NITRIC ACID 4



MIL-A-24641, ACID, HYDROFLUORIC 17

11.13.4.2 Chemical Corrosion Removing Materials for Stainless Steel (CRES) and Nickel Based Alloys. There are three types of chemicals used for corrosion removal from stainless steels (CRES) and nickel based alloys: Semco® Pasa-Jell 101 gel type mineral acid material; MIL-C-10578, Type III inhibited phosphoric acid based solution; and acid pickling solutions consisting of a mixture of A-A-59105 (O-N-350) Nitric Acid, MIL-A-24641 Hydrofluoric Acid, and water.

11.13.4.2.1 Semco® Pasa-Jell 101. This is a gel type mineral acid material used for chemical corrosion removal from assembled equipment structures in areas involving LOX storage and gaseous oxygen transfer systems and other areas where a gel type material is necessary and/or preferred. The directions for the application and use of this material are found in Chapter 5 of TO 1-1-691.

11.13.4.2.2 MIL-C-10578, Type III Corrosion Removing and Metal Conditioning Compound (Phosphoric Acid Base)/Inhibited. This is a phosphoric acid based material that can be used to remove corrosion from assembled equipment structures in areas that do not contain oxygen systems and where a liquid material is acceptable. The directions for the application and use of this material are found in Chapter 5 of TO 1-1-691.

**NOTE**

This process is for DEPOT AND OTHER AUTHORIZED FACILITY use only.

11.13.4.2.3 Acid Pickling for Corrosion Removal. Acid pickling solutions consisting of a mixture of A-A-59105 (O-N-350) Nitric Acid, MIL-A-24641 Hydrofluoric Acid, and water are used to remove corrosion/rust from removed stainless steel (CRES) and nickel based alloy parts that can be immersed in the solution.

**WARNING**

- Scale loosening, pickling, and passivation solutions are all strong acids which are toxic to the skin, eyes, and respiratory tract. Chemical splash proof goggles and/or face shield and chemical resistant rubber gloves and aprons are required.
- In case of eye or skin contact, flush immediately with water and report to the Base Medical Facility.
- Avoid inhaling fumes, and provide adequate ventilation.
- Solution tanks shall be properly ventilated with a lateral exhaust type ventilation system.
- The ventilation system and procedure shall be properly evaluated by the Bioenvironmental Engineer prior to initial use.
- When preparing pickling solutions, never pour water into the acids as excessive heat will be generated. Always pour the acids into the water.
- Rubber lined or Koroseal tanks shall be used to hold these solutions because they are so highly acidic.

**CAUTION**

Heat-treatable stainless steel alloys, such as AISI types 403, 410, 420, and others, are susceptible to cracking when placed in pickling solutions. Use only mechanical methods to remove corrosion from these alloys.

11.13.4.2.3.1 Pickling Solution Concentration. Pickling solutions are prepared by mixing various amounts of A-A-

59105 (O-N-350), Nitric Acid, and MIL-A-24641, Hydrofluoric Acid, in water. The correct content of the two acids for a given corrosion removal job is determined by the testing procedure outlined below. The nitric acid content may vary from 5 to 50% by volume, while the hydrofluoric acid content may vary from 0.5 to 5% by volume. A solution of 12 to 15% nitric acid by volume and 1% hydrofluoric acid by volume in water is normally used to remove light scale and/or corrosion/rust. Increase the percentage of hydrofluoric acid within the range specified above to remove heavier scale and/or corrosion/rust. As the amount of nitric acid increases with respect to the amount of hydrofluoric acid in the solution, the rate of corrosion/rust and/or scale removal decreases, because nitric acid inhibits the action of hydrofluoric acid.

**11.13.4.2.3.2 Pickling Solution Temperature.** The temperature of the pickling solution may be adjusted from ambient/room temperature up to a maximum of 140 °F (60 °C). Higher temperatures shall be avoided to reduce evaporation loss of hydrofluoric acid. Use temperatures below 120 °F (49 °C) if intergranular attack is experienced in localized areas, such as weld zones.

#### NOTE

AISI 300 series stainless steel (CRES) alloy tubing may be used to manufacture steam coils to heat the solution. The heating coils should be installed so that they are easily replaced, since they will be corroded by the solution over time.

**11.13.4.2.3.3 Testing for Optimum Pickling Conditions.** Optimum pickling conditions (temperature, time, and acid concentration) shall be determined by exposing test panels to various combinations of these parameters and processing them through the entire cleaning and corrosion removal/pickling cycle. Excessive etching and/or intergranular attack of the base metal indicates conditions are too aggressive, and slow removal rates indicate conditions are not aggressive enough.

- a. Make four inch square test panels from the same material from which the parts that will be treated are made. Process these test panels through the complete cleaning and corrosion removal/pickling cycle.
- b. If etching or intergranular attack is excessive (i.e., would cause the component to be condemned), or if corrosion removal is not complete, adjust the acid concentration, immersion time, and/or solution temperature until the desired result is obtained. Table 5-9 in Chapter 5 of TO 1-1-691 shows the effect that varying the parameters of acid concentration, immersion time, and/or solution temperature has on the corrosion removal/pickling action of the solution.

**11.13.4.2.3.4 Application and Use of Acid Pickling Solutions for Corrosion Removal.** The directions for the application and use of nitric acid-hydrofluoric acid solutions for corrosion removal are found in Chapter 5 of TO 1-1-691.

**11.13.5 Copper and Copper Based Alloys.** These paragraphs outline chemical corrosion removal procedures for copper and copper based alloy parts and assemblies of aircraft, missiles, and equipment. Table 5-10 in Chapter 5 of TO 1-1-691 provides procedures for removing specific types of corrosion.

**11.13.5.1 Preparation.** If the corroded area is contaminated with grease, oil, dirt, or other foreign materials; clean the area per Chapter 7 of this manual. Protect adjacent components and areas not being treated by masking to prevent damaging them with the chemicals used.



MIL-C-10578, COMPOUND, CORROSION REMOVING AND METAL CONDITIONING

20



A-A-55828 (O-S-809), SULFURIC ACID SOLUTIONS

3

**11.13.5.2 Chemical Corrosion Removing Materials for Copper and Copper Based Alloys.** There are two types of chemical solutions used for corrosion removal from copper and copper based alloys provided there is no danger of chemical entrapment in crevices and/or recesses: MIL-C-10578, Type III Corrosion Removing and Metal Conditioning Compound (Phosphoric Acid Base)/Inhibited solution and A-A-55828 (O-S-809) Sulfuric Acid solution.

**11.13.5.2.1 MIL-C-10578, Type III Corrosion Removing and Metal Conditioning Compound (Phosphoric Acid Base)/Inhibited.** This is a phosphoric acid based material used to remove corrosion from assembled copper and/or copper alloy equipment structures in areas that do not contain oxygen systems and where a liquid material is acceptable. The directions for the application and use of this material are found in Chapter 5 of TO 1-1-691.

**11.13.5.2.2 A-A-55828 (O-S-809) Sulfuric Acid Solutions.** This process is restricted to DEPOT LEVEL maintenance only. Sulfuric acid solutions may be used to remove corrosion from copper and/or copper alloy components which can be disassembled and treated in immersion tanks. The tanks must be either manufactured from or lined with stainless steel

## TO 1-1-700

(CRES), lead, ceramic, glass, or acid resistant rubber; and they must be provided with an adequate lateral exhaust ventilation system. Part holding racks must be manufactured from either stainless steel (CRES) or Monel. The proper conditions (i.e., time, temperature, and acid concentration) for the process shall be determined by the same test procedure outlined in paragraph 11.13.4.2.3.3 in this manual using test panels made from the same material being treated. The directions for the application and use of this material are found in Chapter 5 of TO 1-1-691.

**11.13.6 Titanium and Titanium Based Alloys.** These paragraphs outline chemical corrosion removal procedures for titanium and titanium alloy parts and assemblies. Table 5-11 in Chapter 5 of TO 1-1-691 provides procedures for removing specific types of corrosion.

**11.13.6.1 Preparation.** If the corroded area is contaminated with grease, oil, dirt, or other foreign materials; clean the area per Chapter 7 of this manual.

- Protect adjacent unaffected areas not being treated by masking to prevent damage from scale, chips, corrosion products, or chemicals.
- If present, remove gray or black oxides by an appropriate mechanical method in this chapter.



A-A-59105 (O-N-350), NITRIC ACID

4



MIL-A-24641, ACID, HYDROFLUORIC

17



SAE AMS-1640 (MIL-C-38334), CORROSION REMOVING COMPOUND

60

**11.13.6.2 Chemical Corrosion Removal Materials for Titanium and Titanium Based Alloys.** There are two types of chemical solutions used for corrosion removal from titanium and titanium based alloys: an acid pickling solution of A-A-59105 (O-N-350), Nitric Acid, and MIL-A-24641, Hydrofluoric Acid, in water; and an SAE AMS-1640 (MIL-C-38334) corrosion removing compound solution.



Titanium is susceptible to hydrogen embrittlement in acid solutions. Therefore, acid pickling shall be used only when other corrosion methods are not adequate. Competent operators must be assigned to monitor the process.

**11.13.6.2.1 Acid Pickling Solutions.** This process is restricted to DEPOT LEVEL maintenance only. An acid pickling solution for removing corrosion from removed titanium and titanium alloy parts consists of a mixture of 20% by volume, A-A-59105 (O-N-350), Nitric Acid, and 3% by volume, MIL-A-24641, Hydrofluoric Acid, in water. This solution will remove most oxide coatings from titanium, provided the scale was formed at temperatures below 1000 °F (538 °C) by immersing them in the solution. As noted in paragraph 11.13.6.1, step b, gray or black oxides which form at temperatures above 1000 °F (538 °C) should be removed by an appropriate mechanical method in this chapter, such as abrasive blasting, prior to the acid pickling to prevent pitting of the titanium. The directions for the application and use of these materials are found in Chapter 5 of TO 1-1-691.

**11.13.6.2.2 SAE AMS-1640 (MIL-C-38334) Corrosion Removal Compound Solutions.** This is the same material used to remove corrosion from aluminum alloy surfaces, and it may also be used to remove corrosion from titanium and titanium alloy assemblies and/or on equipment surfaces. Refer to paragraph 11.13.1.2.1 in this manual and Chapter 5 in TO 1-1-691. The procedure for application and use of this corrosion removal compound to remove corrosion products/oxides from titanium and titanium alloy surfaces is the same as it is for aluminum alloy surfaces. Refer to paragraph 11.13.1.2.1.1 in this manual and Chapter 5 in TO 1-1-691.



MIL-DTL-81706 (ALODINE), COATING, CHEMICAL CONVERSION

23

**11.13.6.3 Application of Organic Coatings.** Titanium and titanium alloys do not normally require a paint system for corrosion protection. Where organic finishes are required for camouflage purposes, for continuity with the finish system on surrounding surfaces, or to provide a barrier to prevent contact with a dissimilar anodic material, prepare the titanium or titanium alloy surface for painting by applying a thixotropic MIL-DTL-81706/MIL-DTL-5541, Class 1A chemical chromate conversion coating solution per Section II of Chapter 5 in TO 1-1-691. Apply the organic finish system specified in the applica-

ble system specific equipment maintenance manual and/or engineering drawing and TO 35-1-3 for support equipment (SE) using TO 1-1-8 for application procedures.

**11.13.7 Plated and Phosphate Surfaces.** The following paragraphs outline chemical corrosion removal procedures for removing corrosion from plated and phosphate surfaces. Table 11-6 provides guidelines for touch-up of corroded areas, but where an organic finish on the plated or phosphate part is specified and/or required for engineering or other reasons, the table can be used as a guide for treating the entire surface of the plated or phosphate parts. Chemical corrosion removal using acid type chemical corrosion/rust removers is recommended for use where there is no danger of the chemicals becoming entrapped in crevices or recesses. They are intended for brush application following removal of heavy corrosion by an appropriate mechanical means in this chapter, to remove the remaining red rust and other types of corrosion from the

base metal, and to condition the metal surface for better paint adhesion.

**WARNING**

Many platings and their corrosion products, such as copper, cadmium, and chromium are toxic. Take proper safety precautions to avoid inhalation or ingestion of residue created during corrosion removal operations. Wash hands thoroughly before eating, drinking or smoking after removing corrosion from plated surfaces.

**11.13.7.1 Preparation.** If the corroded area is contaminated by grease, oil, dirt, or other foreign materials; clean the area per Chapter 7 of this manual. Protect adjacent components and areas by masking to prevent damage from scale, chips, corrosion products, and the chemicals used.

**Table 11-6. Typical Chemical Corrosion Removal Procedures for Plated and Phosphate Surfaces**

Type of Corrosion	Corrosion Removal	Protective Finish *
 <p>MIL-C-10578, COMPOUND, CORROSION REMOVING AND METAL CONDITIONING 20</p>		
Light corrosion of plating and base metal under and at breaks in cadmium or zinc platings	Remove corrosion from plating and base metal with an abrasive paper, cloth, or mat. Complete corrosion removal and condition metal with MIL-C-10578, Type I wash-off, phosphoric acid base corrosion removing and conditioning compound (see paragraphs 11.13.7.2.1 and 11.13.3.1.6.1).	Refer to TO 1-1-8 for application of protective finish.
Light corrosion of base metal under and at breaks in tin, chromium, nickel, or copper platings	Remove corrosion from the base metal, using an appropriate hand mechanical method in this chapter, followed by metal conditioning with MIL-C-10578, Type I wash-off, phosphoric acid base corrosion removing and conditioning compound (see paragraphs 11.13.7.3.1 and 11.13.3.1.6.1).	As above
Heavy corrosion of base metal under and at breaks in cadmium, zinc, chromium, nickel, or copper platings	As above	As above
Light to heavy corrosion of base metal under and at breaks in phosphate coatings	Remove corrosion by method used for corrosion removal on the base metal	As above

\* Protective finish should be applied only when the service temperature of the part does not preclude use of an organic coating and/or where the film thickness of the coating will not impair the operation of the part.

## TO 1-1-700

**11.13.7.2 Treatment of Corroded Areas on Cadmium or Zinc Plated Surfaces.** Cadmium and zinc platings provide anodic protection to underlying steel (ferrous) and sometimes copper base metals. If the plating surface is broken during normal usage, the cadmium or zinc plate, being anodic to the base metal, will corrode preferentially and sacrificially protect the base metal. The removal of corrosion from cadmium or zinc plated surfaces shall be limited to the removal of the plating and the base metal corrosion products from the localized area of the underlying base metal. The directions for the application and use of chemical removers on these plated surfaces are found in Table 5-12 in Chapter 5 of TO 1-1-691.

**NOTE**

These procedures are intended only for field level treatment of localized corroded areas on cadmium or zinc plated surfaces and reapplication of a protective coating after corrosion removal. When the use of organic finishes or the thickness of the organic finish will impair the normal operation of a part, severely corroded parts must be removed and replaced. Where facilities are available, parts with severely corroded cadmium or zinc plating may be stripped and replated in accordance with procedures in TO 42C2-1-7. Small areas with severe corrosion may be replated by brush plating per MIL-STD-8651 using procedures in TO 42C2-1-7. When high strength steels are being replated, use only those specialized procedures authorized for high strength steels as many plating solutions can cause hydrogen embrittlement of these materials.

**11.13.7.3 Treatment of Corroded Areas on Plated Surfaces Except Cadmium or Zinc Plating.** When a break occurs in the surface of either chromium, nickel, tin, or copper platings, corrosion of the steel/ferrous base metal and undercutting of the plating will rapidly follow. The corrosion will occur at a highly accelerated rate due to the galvanic action of these platings which are highly cathodic to the steel (ferrous) base metals. Directions for the application and use of chemical removers on plated surfaces except cadmium and zinc platings are found in Table 5-12 in Chapter 5 of TO 1-1-691.

**NOTE**

These procedures are intended only for field level treatment of localized corroded areas on chromium, nickel, tin, and copper plated surfaces. Where service temperatures preclude the use of organic finishes and/or the film thickness of the organic finish will impair normal operation of the part, severely corroded parts must be removed and replaced. Small areas with severe corrosion may be replated by brush plating per MIL-STD-8651 using procedures in TO 42C2-1-7. Where facilities are available, severely corroded parts with chromium, nickel, tin, or copper plating may be stripped and replated in accordance with procedures in TO 42C2-1-7. When high strength steels are being replated, use only those specialized procedures authorized for high strength steels as many plating solutions can cause hydrogen embrittlement of these materials.

**11.13.7.4 Treatment of Corroded Areas on Phosphate Surfaces.** Cadmium and zinc plated surfaces as well as many bare steel surfaces are treated with a phosphate coating at the time of manufacture to improve paint adhesion and corrosion resistance of the surfaces or as a base for the application of grease, oil, or CPCs. When phosphate surfaces corrode, corrosion should be removed by the method recommended for the base material.

**11.13.8 Application of Organic Coatings.** Organic coatings may be applied to phosphate surfaces and some plated surfaces to provide corrosion protection to the plating and/or to increase the corrosion protection the plating or phosphate coating provides to the base metal. They should not be used when the part operates at temperatures which preclude their use or when the finish will prevent the part from performing its intended function. Organic coatings shall not be used on bearing or wearing surfaces of gears, cams, slides, etc., and on surfaces requiring electrical conductivity. Apply the organic finish system specified in the applicable system specific equipment maintenance manual and/or engineering drawing and TO 35-1-3 for support equipment (SE) using TO 1-1-8 for application procedures.



## CHAPTER 12 SEALANTS

### 12.1 PURPOSE.

This chapter covers sealing compounds and procedures for their application. When properly applied, sealants prevent the intrusion of moisture from condensation, rain, and salt water as well as dust, dirt, and fluids into joint areas where they can cause extensive corrosion. Sealants are one of the most important tools for corrosion prevention and control. To be effective, it is critical that the correct sealant be chosen for a specific area/situation and that it be applied correctly. Only qualified personnel thoroughly familiar with sealants and their application shall be permitted to handle and apply them.

### 12.2 APPLICATIONS.

Sealants are used for the following reasons:

- Fuel sealing (fuel tanks and delivery components).
- Weather and fluid sealing (exterior and interior skin and structural joints and surfaces).
- Electrical sealing (bulkhead wiring, electrical connectors and components).
- Acid-resistant sealing (battery compartments).
- High temperature sealing

### 12.3 SEALING COMPOUNDS.

Table 12-1 lists approved sealing compounds, and their available types, properties, and intended use. Refer to the applicable maintenance manual and paragraph 12-7 for specific information concerning selection of the proper sealing compound and its application. Observe the warnings and cautions in paragraph 12-6 when using any sealing compound.

#### NOTE

See the Appendix A in TOs 1-1-691 and 1-1-689-5 for procurement information on sealants (NSNs, quantities, etc.)

12.3.1 Sealant Packaging. Sealants are generally packaged and available as three different types of packaging or units of issue (U/I):

12.3.1.1 Two-Part Kit (KT). The package consists of two separate containers, usually metal cans; one contains the catalyst (part A) and the other contains the base compound (part B), each in pre-measured amounts for mixing together.

12.3.1.2 Cartridge (CA). Cartridges come in two different types: one for single component sealants and one for two component sealants.

12.3.1.2.1 Single component sealants are contained in a plastic cartridge or tube in a ready to use condition requiring no mixing. If some of a single component sealant remains after a job, it can be stored and used at a future time as long as the cartridge/tube is tightly capped at the nozzle opening to prevent contact with air.

12.3.1.2.2 Two component sealants are packaged in Semkits® which are complete plastic cartridge assemblies that store both sealant components (each in separate chambers). Mixing of sealant materials is accomplished within the assembly, which is then used for application. Semkits® are convenient because they eliminate the need to measure and handle the materials for mixing, and generate less waste as they contain small quantities for small area applications.

12.3.1.3 Premixed and Frozen (PMF). Two component sealants can be premeasured, mixed, and frozen at temperatures of -40 °F (-40 °C) and stored at temperatures of -20 °F (-29 °C) or lower with the unit of issue being in ounces. The PMF material in plastic tubes is a convenient package configuration for low and intermittent usage applications, particularly in depot level operations. Simply thaw the material and use.

12.3.2 Polysulfide, Polyurethane, and Polythioether Sealing Compounds. All these materials are two component with the Part B base containing the prepolymer and the Part A catalyst containing the curing agent packaged in separate containers supplied together as a kit. When thoroughly mixed, the catalyst cures the prepolymer to a rubbery solid. The rate of cure depend on the type of prepolymer and catalyst, as well as the temperature and humidity. Full cure of these materials may require as long as 7 days. Refer to Table 12-1 for a general description of these materials.

## TO 1-1-700



MIL-A-46106, ADHESIVE/SEALANT, SILICONE RTV,  
CORROSIVE

18



MIL-A-46146, ADHESIVE/SEALANT, SILICONE RTV,  
NON-CORROSIVE, GROUP I/II/III, TYPE I OR  
GROUP I, TYPE II

19



Room Temperature Vulcanizing (RTV) silicones  
conforming to MIL-A-46106 produce acetic acid

(vinegar smell) which is corrosive. Therefore, as a  
rule of thumb, if the RTV silicone material smells  
like vinegar, don't use it unless required by the equip-  
ment specific manual.

12.3.3 Silicone Sealing Compounds. These materials are  
generally one component Room Temperature Vulcanizing  
(RTV) materials which cure by reacting with moisture in the  
air. If silicones are applied too thick or in such a way that  
moisture is prevented from entering the material, they may not  
cure at all. In addition, many unauthorized silicone sealing  
compounds produce acetic acid, indicated by a vinegar smell,  
while curing which can lead to severe corrosion problems.  
There are two silicone sealant specifications, MIL-A-46146  
and MIL-A-46106. Only MIL-A-46146 materials are non-cor-  
rosive. MIL-A-46106 materials give off acetic acid while cur-  
ing and shall not be used on Air Force equipment, in particular  
on electronic and electrical equipment unless specifically  
required by the equipment specific manual.

**Table 12-1. Sealing Compounds**

Specification	Types Available	Properties	Intended Use
MIL-PRF-81733, SEALING AND COATING COMPOUND, CORROSION INHIBITIVE			48
MIL-PRF-81733 (supersedes MIL-S-81733), Sealing and Coating Compound, Corrosion Inhibitive Class 1 - Polysulfide Class 2 - Polythioether  Grade A - Chromate Inhibitors  Grade B - Non-Chromate Inhibitors	Type I (thin) - for brush or dip application  Type II (thick) - for sealant gun or spatula application  Type III (sprayable) - for spray gun applica- tion  Type IV (spreadable) - for faying surface seal- ing requiring extended assembly times	Two-components:  Room Temp Cure;  Service Temp: -65 °F to +250 ° F (-54 °C to +121 °C);  Peel strength: 15 lb/in width (min); Corrosion inhibiting;  Resists fuel, oil, and hydraulic fluid.	Sealing faying surfaces and for wet installation of fasten- ers on permanent structure repairs. Class 1, Grade A materials are the preferred sealants for these applica- tions as they provide the best corrosion protection.

Table 12-1. Sealing Compounds - Continued



Specification	Types Available	Properties	Intended Use
			
	SAE AMS-S-8802, SEALING COMPOUND (POLYSULFIDE)		62
			
	SAE AMS-3276 (MIL-S-83430), SEALING COMPOUND, INTEGRAL FUEL TANK		59
SAE AMS-S-8802 (supersedes MIL-S-8802), Sealing Compound, Temperature Resistant, Integral Fuel Tanks and Fuel Cell Cavities, High Adhesion (Polysulfide)	<p>Class A (thin) - for brush application</p> <p>Class B (thick) - for sealant gun or spatula</p> <p>Class C (spreadable) - for use where extended assembly times are required</p>	<p>Two-components;</p> <p>Room temp cure;</p> <p>Service temp: -65 °F to +250 °F (-54 °C to + 121 °C);</p> <p>Peel strength: 20 lb/in width (min);</p> <p>No corrosion inhibitors;</p> <p>Resists fuel, oil, and hydraulic fluid.</p>	<p>Used for sealing voids and cavities. Not to be exposed to fuel or overcoated until tack-free.</p> <p>NOTE: Although this sealant was originally intended for sealing integral fuel tanks on aircraft, it is included here because it is used for other applications.</p>
SAE AMS 3276 (supersedes MIL-S-83430), Sealing Compound, Integral Fuel Tanks and General Purpose (Polysulfide)	<p>Class A (thin) - for brush application</p> <p>Class B (thick) - for sealant gun or spatula application</p> <p>Class C (thick) - for use where extended assembly times are required</p> <p>Class D (thick) - for hole and void filling</p> <p>Class E (thick) - for automatic riveting equipment application</p>	<p>Two-components;</p> <p>Room temp cure;</p> <p>Service Temp: -65 °F to +250 °F (-54 °C to + 121 °C) sustained, intermittent (about 6 hours max.) exposure to 360 °F (182 °C);</p> <p>Peel strength: 20 lb/in width (min.);</p> <p>No corrosion inhibitors</p> <p>Resists fuel, oil, and hydraulic fluid.</p>	<p>For higher temperature applications. Used for hole and void filling; for faying surface sealing, wet-installation of fasteners, overcoating fasteners, and sealing joints and seams in fuel wet areas; and for non-structural adhesive bonding. Treat bond surfaces with SAE AMS 3100 adhesion promoter to enhance sealant adhesion.</p> <p>NOTE: Although this sealant was originally intended for sealing integral fuel tanks on aircraft, it is included here because it is used for other applications.</p>

Table 12-1. Sealing Compounds - Continued



Specification	Types Available	Properties	Intended Use
	 <p>PR-1773, SEALING COMPOUND, LOW ADHESION, NON-CHROMATE CORROSION INHIBITORS</p>		57
	 <p>SAE AMS-3267 (MIL-S-8784), SEALING COMPOUND, RUBBER, HEAT RESISTANT</p>		58
PR-1773, (supersedes PR-1403G), Sealing Compound, Non-Chromate Corrosion Inhibitive Polysulfide Rubber Cage Code #83574	Class B (thick) - for sealant gun or spatula application	Two-components; Room Temp Cure; Service Temp: -65 °F to +250 °F (-54 °C to +121 °C); Peel strength: 2 lb/in width (max) Corrosion inhibitors; Resists fuel, oil, and hydraulic fluid.	Preferred sealant for general purpose, low adhesion sealing of access doors, floor panels and plates, removable panels, and Formed-in-Place (FIP) gaskets in non-fuel areas. Can be used to repair defects in FIP Gaskets.
SAE AMS 3267 /1, /2, /3, & /4 (supersedes MIL-S-8784), Sealing Compound, Low Adhesion, Corrosion Inhibiting, For Removable Panels and Fuel Tank Inspection Plates  /1= Class A-1/2 /2= Class B-1/2 /3= Class A-2 /4= Class B-2	Class A (thin) - for brush application  Class B (thick) - for sealant gun or spatula application	Two-components; Room temp cure; Service temp: -65 °F to +250 °F (-54 °C to +121°C); Peel strength: 4lb/in width (max); Corrosion inhibitors; Resists fuel, oil, and hydraulic fluid.	Polysulfide rubber sealing compound for fillet and faying surface sealing of removable structure such as access doors, floor panels and plates, removable panels, and fuel tank inspection plates. Not for high temp areas or permanent structure.

Table 12-1. Sealing Compounds - Continued





Specification	Types Available	Properties	Intended Use
	 		
	SAE AMS 3374, SEALANT, SILICONE		75
	  		
	MIL-S-85420, SEALING COMPOUND, QUICK REPAIR, LOW TEMPERATURE CURING		53
SAE AMS 3374 /1, /2, /3, & /4 (supersedes MIL-S-38249), Sealing Compound, Aircraft Firewall  /1= Type 1 /2= Type 2 /3= Type 3 /4= Type 4	Type 1 (one-part high temp. silicone) - condensation cured  Type 2 (two-part high temp. silicone) - addition cured  Type 3 (two-part high temp. silicone) - condensation cured  Type 4 (two-part polysulfide)	One-component, Type 1; Two components, Types 2, 3, & 4;  Room temp cure;  Service Temp; -65 °F to +400 °F (-54 °C to + 204 °C); withstands flash temperature of 2000 °F (1093 °C);  Peel strength: 10 lb/in width (min);  No corrosion inhibitors;  Resists fuel, oil, and hydraulic fluid.	Sealing structures exposed to very high temperatures against the passage of air and vapors. Cures on exposure to air.  NOTE: Although this sealant was originally intended for sealing aircraft firewalls, it is included here because it is used for other applications.
MIL-S-85420, Sealing Compounds, Quick Repair, Low Temperature Curing Polysulfide, for Aircraft Structures  Type I dichromate cure system Type II manganese cure system	Class A (thin) - for brush application  Class B (thick) - for sealant gun or spatula application	Two-components;  Low Temp Cure;  Service Temp: -65 °F to +200 °F (-54 °C to + 93 °C);  Peel strength: 10 lb/in width (min);  No corrosion inhibitors;  Resists fuel, oil, and hydraulic fluid.	Quick repair sealing of structures at low temperatures. Use only with the recommended adhesion promoter/primer for optimum results. This sealant should be stored at a temperature not to exceed +80 °F or poor adhesion will result.  NOTE: Although this sealant was originally intended for sealing aircraft structures, it is included here because it is used for other applications.

Table 12-1. Sealing Compounds - Continued

Specification	Types Available	Properties	Intended Use
 <p data-bbox="462 409 995 457">SAE AMS-3277 (MIL-S-29574), SEALING COMPOUND, LOW TEMPERATURE CURING</p> <p data-bbox="1295 432 1325 457">61</p>			
<p data-bbox="77 485 386 667">MIL-S-29574 (SAE AMS 3277), Sealing Compound, Polythioether, for Fuel and High Temperature Resistant, Fast Curing at Ambient and Low Temperatures</p> <p data-bbox="77 705 415 1020">Type I - No corrosion inhibitors; intermittent use to +400 °F (+204 °C); Grade A general use, fuel tanks Grade A1 ambient or immediate heat cure after application at temps. up to 350 °F (175 °C); Classes B &amp; C only; Grade B enhanced craze resistance for acrylic transparencies;</p> <p data-bbox="77 1058 386 1146">Type II Corrosion inhibitive; intermittent use to 360 °F (182 °C)</p>	<p data-bbox="448 485 651 541">Class A (thin) - for brush application</p> <p data-bbox="448 579 683 636">Class B (thick) - for sealant gun or spatula</p> <p data-bbox="448 674 699 793">Class C (semi-thick) - extended assembly times for faying surface sealing</p>	<p data-bbox="732 485 911 510">Two-component;</p> <p data-bbox="732 548 1089 667">Low (down to +20 °F / -7 °C) and ambient temp. curing; Type I, Grade A1 only - can be heat cured at temps. up to +350 °F (+175 °C)</p> <p data-bbox="732 705 1089 856">Service temp: -80 °F to +300 °F (-68 °C to +150 °C) with intermittent use to +400 °F (+204 °C) for Type I &amp; +360 °F (+182 °C) for Type II;</p> <p data-bbox="732 894 1032 951">Peel strength: 20 lb/in width (min);</p> <p data-bbox="732 989 1049 1077">Corrosion inhibiting - Type II only; Type I has no corrosion inhibitors;</p> <p data-bbox="732 1115 1057 1171">Resists fuel, oil, and hydraulic fluid.</p>	<p data-bbox="1123 485 1430 919">Multi-purpose structure and integral fuel tank sealants with rapid ambient and low temperature curing capabilities. Use of manufacturer's recommended primer is required prior to applying this sealant for proper adhesion. Type I can be used as an alternate for SAE AMS-S-8802 (MIL-S-8802) in fuel tank applications and Type II can be used as an alternate for MIL-PRF-81733.</p> <p data-bbox="1123 957 1430 1108">NOTE: Although this sealant was originally intended for sealing aircraft structures, it is included here because it is used for other applications.</p>



Table 12-1. Sealing Compounds - Continued

Specification	Types Available	Properties	Intended Use
 <p>MIL-A-46146, ADHESIVE/SEALANT, SILICONE RTV, NON-CORROSIVE, GROUP I/II/III, TYPE I OR GROUP I, TYPE II</p>			
<p>MIL-A-46146, Adhesive - Sealants, Silicone, Room Temperature Vulcanizing (RTV), Non-corrosive (For Use With Sensitive Metals and Equipment)</p>	<p>Group I - General purpose</p> <p>Group II - High strength</p> <p>Group III - High temperature</p> <p>Each group has two types:</p> <p>Type I Thixotropic paste</p> <p>Type II Self-leveling liquid</p>	<p>One-component;</p> <p>Room temp cure;</p> <p>Service Temp; -70 °F to +400 °F (-57 °C to +204 °C) for Groups I &amp; II, and -70 °F to +600 °F (-57 °C to +316 °C) for Group III;</p> <p>Peel strength:</p> <p>Group I, Type I: 15 lbs./in. width (min) Type II: 4 lbs./in. width (min);</p> <p>Groups II &amp; III (both types): 40 lbs./in. width (min);</p> <p>No corrosion inhibitors</p> <p>Long shelf life;</p> <p>Short cure time.</p>	<p>19</p> <p>Convenient one-component, non-corrosive, RTV silicone sealant for use with sensitive metals and equipment. Not to be used where resistance to fuels, oils, or hydraulic fluids is required. Check manufacturer's instructions for primer requirements on the metal substrate being sealed, and apply the specified primer before applying the sealant.</p>

Table 12-1. Sealing Compounds - Continued

Specification	Types Available	Properties	Intended Use
 <p>SAE AMS 3255, TAPE, SEALING, POLYTETRAFLUOROETHYLENE 73</p>			
<p>SAE AMS 3255, Sealing Tape, Polytetrafluoroethylene, Expanded (EPTFE) Oil and Water Resistant; (Skyflex)</p>	<p>Class 1: Continuous Ribbed, includes: Skyflex part Nos.:</p> <p>GUA-1071-1 - for fay surfaces &lt;1 inch wide;</p> <p>GUA-1001-1 - for fay surfaces &gt;1 inch wide</p> <p>GUA-1001-2 - for fay surfaces &gt;1 inch wide where thicker tape is needed to fill fay surface gap;</p> <p>GUA-1017-1 - for fay surfaces ≤1 inch wide</p> <p>GUA-1401-1 - for fay surfaces ≤1 inch wide in dry areas of floorboards and where a thicker tape is needed to fill fay surface gaps;</p> <p>GSC-21-80767-00 - for fay surfaces ≤1 inch in high moisture areas of floorboards and where thicker tape is needed to fill fay surface gaps;</p> <p>Class 2: Continuous Non-Ribbed, includes: Skyflex® part Nos.;</p> <p>GUA-1003-1 - compensation tape - a narrow un-ribbed tape used to fill irregularities on a sealing surface or repair minor damage to a previously applied tape seal;</p> <p>GUA-1057-1 - for fay surfaces ≤1 inch wide, used as shim/barrier to resist minor chafing;</p>	<p>Preformed gasket tape with no adhesive on either side except as noted in “Intended Use” column;</p> <p>No mixing, masking, or curing required;</p> <p>Service Temp: -65 °F to +450 °F (-54 °C to +232 °C) with short term exposure to 600 °F (315 °C);</p> <p>Peel strength: 2 lb/in width (max) for side with adhesive only;</p> <p>No corrosion inhibitors;</p> <p>Resists water, fuel, oil, and hydraulic fluid.</p>	<p>Sealing of faying surfaces, access and removable panels, and floorboards. Not for fuel soaked or very high temperature application. Non-hazardous alternative to low adhesion, two component sealants. Some of these sealing tapes have a low peel strength adhesive on one side to hold the tape in place on one surface while the mating part is being installed.</p>

Table 12-1. Sealing Compounds - Continued

Specification	Types Available	Properties	Intended Use
SAE AMS 3255 (continued)	<p>GUA-1058-1 - for fay surfaces &lt;1 inch wide, used as a shim/barrier to resist minor chafing;</p> <p>GUA-1059-1 - for fay surfaces &gt;1 inch wide, used as shim/barrier to resist minor chafing;</p> <p>GUA-1301-1 - for fay surface &lt;1 inch wide with thick gaps.</p>		
Av-Dec ® HiTak® Polyurethane Tape Sealant (part No. HT3935-7-XXX)	<p>-100 for fay surfaces ≤1 inch wide</p> <p>-150 for fay surfaces &gt;1 inch up to 1.5 inches wide</p> <p>-200 for fay surfaces &gt;1.5 inches up to 2 inches wide</p> <p>-250 for fay surfaces &gt;2 inches up to 2.5 inches wide</p>	<p>Preformed gasket tape with adhesive on both sides and thin polyethylene release film on one side;</p> <p>No mixing, masking, or curing required;</p> <p>Service Temp: 85 °F to + 275 °F (-65 °C to +135 °C) will withstand short non-continuous exposure to higher temperatures;</p> <p>Peel Strength: 1-4 lb./in. width;</p> <p>No corrosion inhibitors;</p> <p>Resists water, deicing fluids, fuel, oil, and hydraulic fluid.</p>	<p>For fay surface sealing of areas where fluid intrusion is a problem. For maximum sealing, remove the release film for adhesion to both surfaces. For easier panel removal and maximum reusability, leave the release film in place on the side contacting the removable panel. Damaged sections of the tape are easily repaired as it has very good adhesion to itself.</p>

Table 12-1. Sealing Compounds - Continued

Specification	Types Available	Properties	Intended Use
Av-Dec® HiTak® TufSeal™ Polyurethane Tape Sealant (part No. HT3000-XXX)	<p>-100 for fay surfaces ≤1 inch wide</p> <p>-150 for fay surfaces &gt;1 inch up to 1.5 inches wide</p> <p>-200 for fay surfaces &gt;1.5 inches up to 2 inches wide</p>	<p>Preformed gasket tape with adhesive on one side and a permanent Teflon film backing on the opposite side;</p> <p>No mixing, masking, or curing required;</p> <p>Service Temp: -85 °F to +275 °F (-65 °C to +135 °C);</p> <p>Peel Strength: 2-5 lb./in. width adhesive side only, the other side has a permanent Teflon film backing;</p> <p>No corrosion inhibitors;</p> <p>Resists water, deicing fluids, fuel, oil, and hydraulic fluid.</p>	<p>For fay surface sealing of non-permanent structure such as access and inspection panels/covers to prevent fluid entry into the faying surface areas and the cavities over which the panels/covers are installed. The Teflon® backing is highly abrasion resistant and permits slight movement of the covers without damaging the structure to which it is attached. The tape is very durable, so it may be reused many times once it is installed, and damaged sections are easily repaired as it has very good adhesion to itself.</p>
Av-Dec® Self-Leveling™ Green (part No. HT 3326-5-XXX) and Thixoflex Orange Injectable (part No. TF2219) Sealants	<p>Self Leveling™ Green - for filling voids and/or cavities on horizontal surfaces where a self leveling liquid may be used; supplied in either 50cc (-050) or 200 (-200) cartridges;</p> <p>Thixoflex™ Orange - for filling voids/cavities on horizontal, vertical, or overhead surfaces where a paste material is required; supplied in 50cc cartridges.</p>	<p>Two component sealants; both are supplied in dual syringes containing the required amounts of resin and hardener for mixing on site;</p> <p>Mixing and dispensing is accomplished with accessories obtained from the vendor per the vendor's instructions;</p> <p>Service Temp: -60 °F to +260 °F (-51 °C to +127 °C) either type;</p> <p>Peel Strength: both 1-4 lb./in. width;</p> <p>No corrosion inhibitors;</p> <p>Resists water, deicing fluids, fuel, oil, and hydraulic fluid.</p>	<p>The Self Leveling™ Green sealant is intended to fill void/cavities on horizontal surfaces to prevent fluids from accumulating in them and causing corrosion while still being easily removed for required inspections and/or operational use. Also useful to fill cavities around antenna connectors.</p> <p>The Thixoflex™ Orange sealant is intended for filling the same voids/cavities as above as well as those on vertical and overhead surfaces while still being easily removed for required inspections and/or operational use.</p>



MIL-S-85420, SEALING COMPOUND, QUICK REPAIR,  
LOW TEMPERATURE CURING 53



SAE AMS-3277 (MIL-S-29574), SEALING COMPOUND,  
LOW TEMPERATURE CURING 61



Solvent based adhesion promoters are hygroscopic (absorb moisture) and must be kept away from moisture. Discard material if it becomes cloudy or a precipitate is formed.

**12.3.4 Adhesion Promoters.** Some sealing compounds may require the application of a special primer or adhesion promoter prior to sealant application in order to develop a good adhesive bond with the surface. Use only those primers or adhesion promoters recommended by the manufacturer for his product. These materials are especially important for MIL-S-85420, SAE AMS-3277 (MIL-S-29574) and some silicone based sealants. See Appendix A in TO 1-1-691 for a listing and description of adhesion promoters.



SAE AMS 3255, TAPE, SEALING,  
POLYTETRAFLUOROETHYLENE 73

**12.3.5 SAE AMS 3255 Oil and Water Resistant, Expanded Polytetrafluoroethylene Sealing Tape (EPTFE) (Skyflex®).** The sealant tape consists of an extruded gasket (most of the time with several protruding ribs) with a pressure sensitive adhesive backing. No mixing is required and there are no application life constraints or cure times involved. The sealing tape does not require removal and replacement unless damaged. The adhesive backing is only required to hold the sealing tape in place until an access panel, floor panel, or component is reinstalled. Tapes may be special ordered without adhesive backing for use in areas where fluid exposure (e.g., hydraulic fluid or fuel) is expected and applied with a fluid resistant rubber cement. Refer to Table 12-1 for a general description of these tapes.

## NOTE

Use of the EPTFE (Skyflex®) sealing tape requires authorization from the equipment SPM engineering authority.

**12.3.6 Av-Dec® Polyurethane Sealant Tapes and Two Component Sealants.** Av-Dec® sealing tapes are pre-cured polyurethane gasket tapes with the HT3935-7 series having a tacky adhesive on both sides and the HT3000 series having a tacky adhesive on one side and a permanent Teflon film backing on the other side. These tapes require no mixing, have unlimited application life, and require no cure time. The HT3995-7 series tapes are particularly useful for sealing high moisture areas. The HT3000 series are useful for sealing frequently removed inspection and access panels, since once applied they are totally reusable unless damaged; damaged areas only may be removed and replaced. The HT3326-5 self leveling green liquid and TF2219 thick orange paste materials are two component curable sealants that are particularly useful in filling voids and cavities to prevent moisture and fluid accumulation and subsequent corrosion damage in areas where ease of removal for inspection and/or operational requirements is necessary.

## 12.4 EQUIPMENT.

The following equipment is available:

## NOTE

Avoid air bubbles as much as possible during the filleting operation. Allow the sealant to cure, at least, the tack free stage before moving the assembly.

**12.4.1 Sealant Gun.** The Semco Model 250-A or its equivalent (Figure 12-1) fitted with one of the nozzles from Figure 12-2 is used for the application of fillet seals. When using this gun, the nozzle tip must be pointed into the seam and maintained at a 45 degree angle to the line of travel, forcing the bead of sealing to precede the gun tip to minimize entrapment of air. Use fairing/smoothing tools (i.e., spatulas and spreaders) shown in Figure 12-5 to work sealants and adhesives into seams.



Care should be taken when using rivet nozzles to prevent sealant material from filling fastener holes.

**12.4.2 Application Nozzles.** In addition to the standard, fillet, and ribbon nozzles in Figure 12-2, the countersink and rivet nozzles in Figure 12-3 and Figure 12-4, respectively, can also be used with sealant guns. Countersink nozzles can be

## TO 1-1-700

used to apply sealants into the countersink of fastener holes prior to fastener installation. Rivet nozzles are suitable for use to apply sealants into countersink and through hole prior to fastening part(s) with rivets. The rivet nozzles have a spring-loaded tip. It serves as a check valve and allows for dispensing the precise amount of sealant material.

**12.4.3 Injection Gun.** Figure 12-6 illustrates two types of injection guns used for injecting sealant into confined holes, slots, structural voids, joggles, etc. Follow the procedures outlined in the applicable equipment system specific maintenance manual and the injection gun manufacturer's operation instructions for the proper preparation and use of these guns. For hard to reach areas, attach an extension nozzle to the injection tip.



## MODEL 250-A PNEUMATIC SEALANT DISPENSING GUN (WITH HANDLE)

\*250 (PN = 250255) . . 2-1/2 OZ CAPACITY

250 (PN = 250065) . . 6 OZ CAPACITY

ALL PARTS INTERCHANGEABLE

**NOTES**

1. PLASTIC CARTRIDGE AND STEEL SAFETY RETAINER DETERMINE CAPACITY. ALL OTHER PARTS ARE IDENTICAL.
2. TOTAL WEIGHT (6 FL OZ GUN) - 15 OZ
3. LENGTH OVERALL LESS NOZZLE (6 OZ GUN) - 8-1/2 IN.
4. PISTOL GRIP HANDLE MAY BE REMOVED TO CONVERT TO LEVER THROTTLE FOR CONFINED AREAS.
- \*5. 2-1/2 OZ CAPACITY RECOMMENDED FOR MOST FIELD REPAIRS.

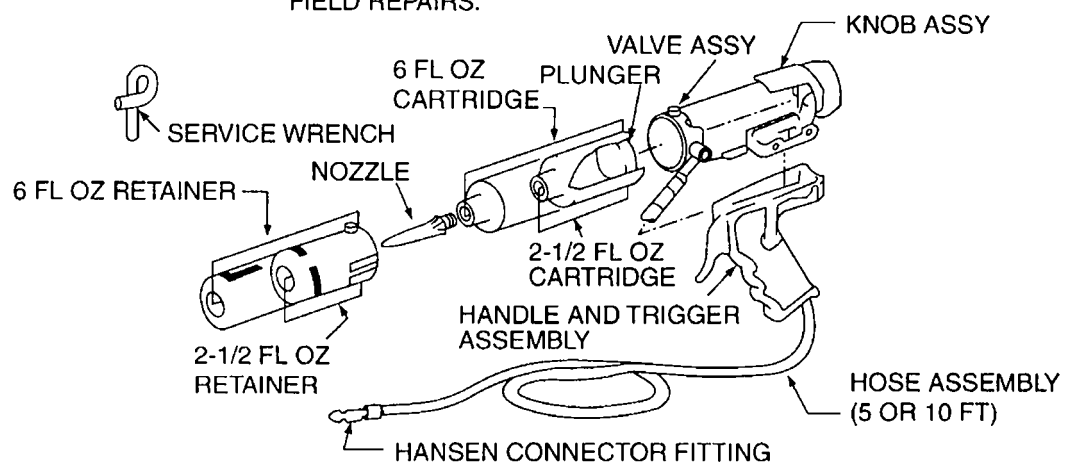
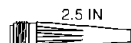
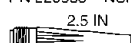
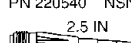
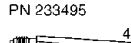
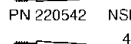
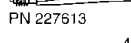
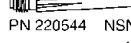
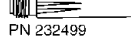
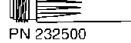
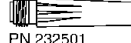
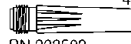

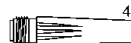

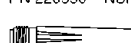
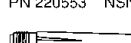
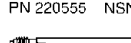
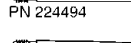
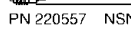
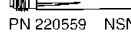
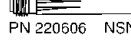
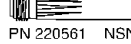

Figure 12-1. Pneumatic Sealant Gun

TO 1-1-700

MODEL NO.

- 252  2.5 IN 1/16 IN ORIFICE  
PN 220538 NSN 5120-00-167-0150
- 254  2.5 IN 1/8 IN ORIFICE  
PN 220540 NSN 5120-00-673-1885
- 255  2.5 IN NO ORIFICE  
PN 233495
- 410  4 IN 1/32 IN ORIFICE  
PN 220542 NSN 5120-00-801-0949
- 415  4 IN NO ORIFICE  
PN 227613
- 420  4 IN 1/13 IN ORIFICE  
PN 220544 NSN 5120-00-042-6577
- 425  4 IN 1/8 IN x 3/8 IN ORIFICE  
PN 232499
- 426  4 IN 1/8 IN x 3/8 IN ORIFICE  
PN 232500
- 427  4 IN 1/8 IN x 3/8 IN ORIFICE  
PN 232501
- 428  4 IN 1/8 IN x 3/8 IN ORIFICE  
PN 232502
- 429  4 IN 1/16 IN x 1/2 IN ORIFICE  
PN 232590
- 430  4 IN 3/32 IN ORIFICE  
PN 220548 NSN 120-00-967-8151
- 440  4 IN 1/8 IN ORIFICE  
PN 220550 NSN 5120-00-773-3791
- 620  6 IN 1/16 IN ORIFICE  
PN 220553 NSN 5120-00-167-0152
- 640  6 IN 1/8 IN ORIFICE  
PN 220555 NSN 5120-00-967-8151
- 650  6 IN 3/8 IN ORIFICE  
PN 224494
- 820  8 IN 1/16 IN ORIFICE  
PN 220557 NSN 5120-00-966-8270
- 840  8 IN 1/8 IN ORIFICE  
PN 220559 NSN 5120-00-966-5372
- 8690  9 IN VENT DUCK NOZZLE 3/32 IN ORIFICE  
PN 220606 NSN 5120-00-966-8243
- 1002  10 IN 1/16 ORIFICE  
PN 220561 NSN 120-00-055-4055
- 1004  10 IN 1/8 IN ORIFICE  
PN 220563 NSN 5120-00-055-4054
- 1010  10 IN 5/16 IN ORIFICE  
PN 220565 NSN 5120-00-055-4058

BENT NOZZLES

WHEN ORDERING BENT NOZZLES, FIRST GIVE MODEL NUMBER, THEN ANGLE OF BEND (D), THEN LENGTH OF BEND FROM TIP (C), i.e. #640, 30, 2 IN

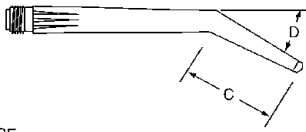

FLOORBOARD NOZZLE  
PN 231674

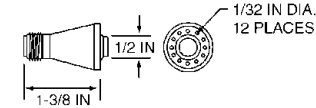

1 IN FUNNEL NOZZLE  
PN 231718

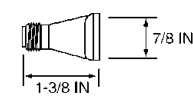



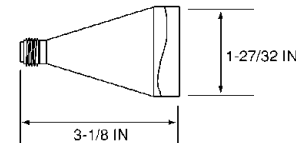

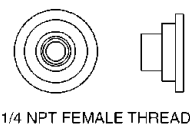

2 IN FUNNEL NOZZLE  
PN 231348

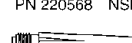
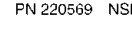
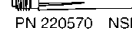

NOZZLE ADAPTER  
PN 229306

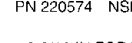

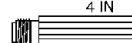
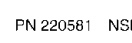
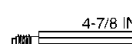
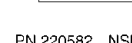

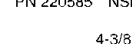
MODEL NO.

- 8607  5-7/8 IN 1/16 IN x 1/4 IN ORIFICE  
PN 220568 NSN 5120-00-966-5381
- 8608  4 IN 11/64 IN ORIFICE  
PN 220569 NSN 5120-00-966-8244
- 8610  4-1/8 IN 3/64 IN x 9/64 IN ORIFICE  
PN 220570 NSN 5120-00-299-6790
- 8613  5 IN 3/64 IN x 3/8 IN ORIFICE  
PN 220572 NSN 5120-00-966-5379
- 8615  4 IN 1/16 IN x 1/2 IN ORIFICE  
PN 220574 NSN 5120-00-966-5378
- 8616  2-3/16 IN FOR WINDSHIELD FILLET 0.218 IN ORIFICE  
PN 220577
- 8630  4 IN 1/8 IN x 1-3/4 IN ORIFICE  
PN 220581 NSN 5120-00-966-5377
- 8630-9  4-7/8 IN 1/8 IN x 1-3/4 IN ORIFICE  
PN 220582 NSN 5120-00-966-5376
- 8642  4 IN 3/16 IN ORIFICE  
PN 220585 NSN 5120-00-293-4676
- 8643  4-3/8 IN 1/8 IN x 3/4 IN ORIFICE  
PN 220586 NSN 5120-00-775-1670
- 8645  4-3/16 IN 1/8 IN x 1 IN ORIFICE  
PN 220587 NSN 5120-00-138-1658
- 8646  3-15/16 IN 1/8 IN x 3/4 IN ORIFICE  
PN 220588 NSN 5120-00-966-5374
- 8648  3-5/8 IN x 5-3/16 IN 1/8 IN x 3/4 IN ORIFICE  
PN 220589 NSN 5120-00-966-5375
- 600E  EXTENSION NOZZLE 6-3/8 IN 1/4 NPT  
PN 220552 NSN 5120-00-670-1187

"SEMCO" IS A TRADEMARK OF PRC-DESOTO INTERNATIONAL, INC.

ALL NOZZLES ARE DESIGNED TO FIT INTO SEMCO CARTRIDGES

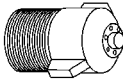
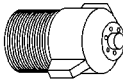
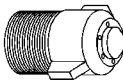
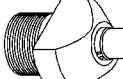
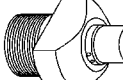
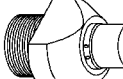
Figure 12-2. Sealant Application Nozzles

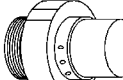
	PART NUMBER	COLOR	SIZE	QUANTITY HOLES
	233244	RED	3/32 IN - 1/8 IN	6 HOLES
	233243	WHITE	3/16 IN - 1/4 IN	6 HOLES
	233451	BLUE	5/16 IN - 3/8 IN	6 HOLES
	231319	YELLOW	1/4 IN HOLE	6 HOLES - 0.028 IN
	231320	GREY	5/16 IN HOLE	6 HOLES - 0.028 IN
	231321	GREEN	3/8 IN HOLE	6 HOLES - 0.028 IN
	231560	RED	7/16 IN HOLE	6 HOLES - 0.028 IN
	231559	BLUE	1/2 IN HOLE	4 HOLES - 0.028 IN

**NOTE**

FASTENER SEALING (COUNTERSINK) NOZZLES ARE USED TO APPLY THE REQUIRED AMOUNT OF SEALANT IN THE COUNTERSINK OF FASTENER HOLES, PRIOR TO INSTALLATION OF FASTENER. WHEN PROPERLY USED, SEALANT WILL BE APPLIED TO THE PERIMETER OF THE COUNTERSINK AND NOT INSIDE THE HOLE. THE ASSORTED FASTENER SEALING NOZZLE SIZES ARE COLOR CODED FOR IDENTIFICATION.

**Figure 12-3. Countersink Application Nozzles**

## TO 1-1-700

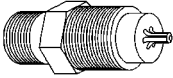
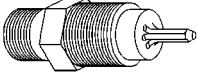
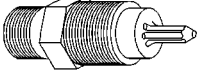
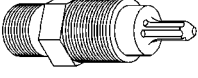
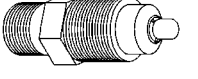
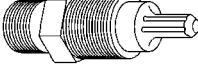
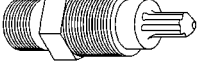
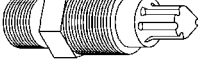
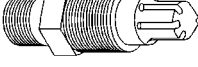
		PART NUMBER	COLOR	FITS HOLE SIZE	SIZE AND QUANTITY OF DISPENSING HOLES
	3/32 IN	234285	GERMAINE GREEN	3/32 IN	0.030 IN DIA, 6 EA EQUALLY SPACED
	1/8 IN	226837	BLUE	1/8 IN	0.031 IN DIA, 6 EA EQUALLY SPACED
	5/32 IN	226838	BLACK	5/32 IN	0.035 IN DIA, 6 EA EQUALLY SPACED
	3/16 IN	226839	WHITE	3/16 IN	0.060 IN DIA, 6 EA EQUALLY SPACED
	3/16 IN-120*	234260*	GREEN	3/16 IN-120*	0.030 IN DIA, 6 EA EQUALLY SPACED
	7/32 IN	234284	LIGHT BLUE	7/32 IN	0.046 IN DIA, 6 EA EQUALLY SPACED
	1/4 IN	226840	RED	1/4 IN	0.044 IN DIA, 6 EA EQUALLY SPACED
	5/16 IN	233051	ORANGE	5/16 IN	0.062 IN DIA, 6 EA EQUALLY SPACED
	3/8 IN	233052	YELLOW	3/8 IN	0.062 IN DIA, 6 EA EQUALLY SPACED

\*PN 234260 APPLIES SEALANT TO COUNTERSINK ONLY.

**NOTE**

RIVET NOZZLES ARE USED TO APPLY THE REQUIRED AMOUNT OF SEALANT INTO THE COUNTERSINK AND THROUGH HOLE PRIOR TO FASTENING PARTS WITH RIVETS. THE SPRING-LOADED TIP OF THE RIVET NOZZLE ACTS AS A CHECK VALVE ALLOWING PRECISE SHOTS OF MATERIAL TO BE DISPENSED. THE ASSORTED SIZES ARE COLOR CODED FOR EASY IDENTIFICATION.

**Figure 12-4. Rivet Application Nozzles - Upper/Lower**

FIBERGLASS REINFORCED PLASTIC SPATULAS AND SPREADERS  
FOR TOOLING AND SMOOTHING SEALANTS AND ADHESIVES.

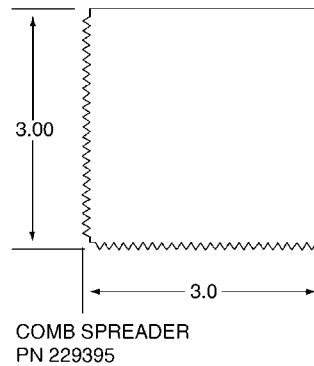
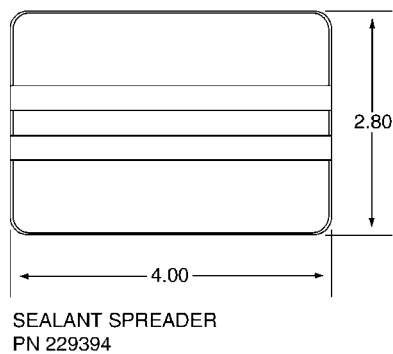
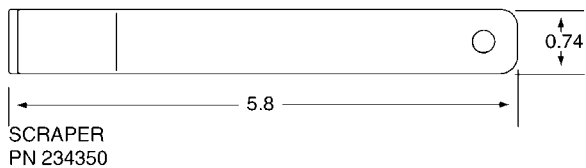
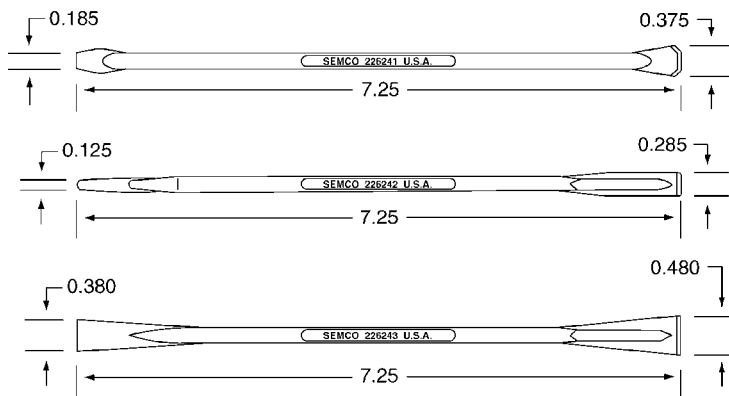
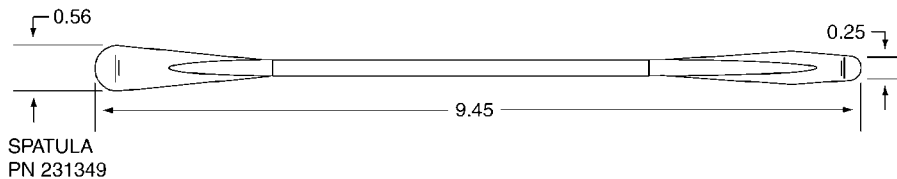

ALL DIMENSIONS SHOWN ARE IN INCHES.

Figure 12-5. Sealant and Adhesive Smoothing Tools

TO 1-1-700



Figure 12-6. Sealant Injection Guns

**CAUTION**

Before using sealant materials, refer to the sealant Material Safety Data Sheet (MSDS) for information on handling precautions.



SAE AMS-S-8802, SEALING COMPOUND  
(POLYSULFIDE)

62



MIL-PRF-81733, SEALING AND COATING COMPOUND,  
CORROSION INHIBITIVE

48

12.4.4 Sealant Kits (Semkits®). Certain types of sealants, such as SAE AMS-S-8802 (MIL-S-8802) and MIL-PRF-81733, are available as ready to use kits (Semkits®). These kits are compact, two-part mixing application units designed for convenient storage, easy mixing, and proper application of the sealant in small quantities. The base component of the sealant is packed in standard 2-1/2 ounce and 6 ounce cartridges which are placed in a filleting gun or injection gun for application after mixing with the accelerator/catalyst. There are two styles: the Barrier Style which holds proportioned amounts of the two components separated by an aluminum barrier disc; and the Injection Style, which stores the accelerator/catalyst material within the injection rod to separate it from the base compound prior to use (Figure 12-7). When using Semkits®, note that the handle or the injection/dasher rod contains a pre-measured amount of accelerator/catalyst and should be retained until the ramrod has been operated to break the seal at the bottom of the injection/dasher rod releasing the accelerator/catalyst into the base component and mixing is completed. All of the materials contained inside these two-



component Semkit® packages are mixed within the cartridges. Follow the manufacturer's recommended storage instructions for these Semkits®.

**12.4.5 Sealant Removal and Application Tools.** The most commonly used tools for removing or fairing out sealants are shown in Figure 12-5. Other tools may be manufactured as needed to fit a specific situation. Only plastic shall be used to manufacture these sealant removal and application tools.

## 12.5 SEALANT MIXING

The proper weighing and mixing of components is essential to assure proper curing and adhesion of sealants. Use an appropriate weight scale (see TO 1-1-691 Appendix B) to accurately measure the materials before blending. Accomplish all mixing in one designated central area in each organization. Polysulfide and polythioether sealants consist of two separately packaged components, a base compound (usually part B) and an accelerator/catalyst (usually part A) in 1/2 pint (6 oz.), pint (12 oz.), and quart (24 oz.) kits. The base-to-accelerator/catalyst ratio varies with different manufacturers of the same type of sealant. It is important, therefore, to mix the material according to the manufacturer's instructions/recommendations. Add accelerator/catalyst into the base in the correct ratio and mix until a uniform color is obtained. Difficulties with curing and/or adhesion of polysulfide and polythioether sealants are frequently caused by incomplete mixing. Two component sealants are chemically cured and do not depend on solvent evaporation for curing. Slow hand mixing is recommended for two - component can type kits. A high speed mechanical mixer should not be used as internal heat will be generated thus reducing application life and introducing air into the mixture. Refer to Figure 12-7 for injection style Semkit® mixing instructions.



MIL-PRF-81733, SEALING AND COATING COMPOUND,  
CORROSION INHIBITIVE 48

- **12.5.1 Application Life.** Application life and cure times are dependant on environmental considerations. The application life of a sealant is the length of time that a mixed scaling compound remains usable at 77 °F (25 °C) and 50% Relative Humidity (RH). This time (in hours), known as a dash number, is denoted as the last number in a sealant designation (e.g., MIL-PRF-81733, Type II-2 has an application life of 2 hours). Table 12-2 indicates application times, tack-free times, and full cure times for each sealant type and dash number at 75 °F and 50% RH. For each 18 °F (10 °C) increase in the temperature above 77 °F (25 °C), the application, tack-free, and cure times are shortened by approximately one-half; while for each 18 °F (10 °C) decrease in the temperature below 77 °F (25 °C),

the application, tack-free, and cure times are lengthened by approximately one-half. For each 15% increase in RH above 50%, the application, tack-free, and cure times are shortened by approximately one-half; while for each 15% decrease in RH below 50%, the application, tack-free, and cure times are lengthened by approximately one-half. Maintenance personnel should be aware of the effects of temperature and humidity on the application life of a sealant. Mix only the amount of material that can be applied during the rated work life of the sealant. There are several corrective measures that can be used to prevent and/or lessen sealant curing problems caused by various environmental conditions.

**12.5.1.1** At a relative humidity of 30% RH or lower (sometimes even 40% RH causes a problem), it is very difficult to properly cure sealants. When these conditions are experienced, adding water vapor to the air to increase the humidity by either wetting down the floor of the facility, covering the area being sealed with a wet cloth without it touching the sealant surface and keeping the cloth wet during the cure cycle, or some other convenient method will eliminate the problem.

### WARNING

Do apply heat sealants until 30 minutes minimum have elapsed at ambient temperature after application to allow the contained solvents to flash off. Most solvents are flammable and could catch fire if sealants are exposed to higher temperatures before the solvents flash off.

### NOTE

If sealants are heated to a temperature of 110 °F (43 °C) or greater as noted in paragraph 12.5.1.2 below, no adjustment to the humidity is required.



MIL-S-85420, SEALING COMPOUND, QUICK REPAIR,  
LOW TEMPERATURE CURING 53



SAE AMS-3277 (MIL-S-29574), SEALING COMPOUND,  
LOW TEMPERATURE CURING 61

**12.5.1.2** Except for MIL-S-85420 and SAE AMS-3277 sealants that are designed to cure properly with good adhesion at low temperatures, sealant curing is extremely slow when applied at ambient air temperatures of 500 °F (100 °C) and

**TO 1-1-700**

below and adhere very poorly to metal structure having a surface temperature of 600 °F (160 °C) and below due to poor surface wetting properties at the time of the application. These problems can be eliminated by preheating the metal surfaces to which a sealant will be applied to a temperature of 600 °F (160 °C) or higher and/or heating the sealant to a temperature of 130 °F ±10 °F (54 °C ±10 °C) after application with hot air, infrared lamps, or some other approved method after allowing the sealant to stand for a minimum of 30 minutes at ambient temperature after it is applied to flash off its contained solvents.

12.5.1.3 Sealants applied to metal surfaces having a surface temperature of 100 °F (35 °C) or greater will very likely have bubbles in the cured sealant film, commonly called “solvent pop,” due to too rapid evaporation of the solvents contained in the sealant. Cool the metal surface down to a temperature of 90 °F (32 °C) or lower by wetting it down with water and then

wiping the surface dry by some other approved method and/or relocate the equipment to which sealant is to be applied to an area having an ambient temperature of 90 °F (32 °C) or lower prior to applying sealant. Keep the equipment in this cooler condition for a minimum of 30 minutes to allow the contained solvents to flash off before relocating the equipment in a hotter area or applying heat to the sealant.

12.5.1.4 Sometimes sealant must be applied in areas where other maintenance is being accomplished which leads to sealant smears in the area caused by walking on and/or dragging tools through sealant that is not completely cured. To minimize this problem, apply a polyurethane film over the uncured sealant after allowing a minimum of 30 minutes at ambient temperature after it is applied to flash off its contained solvents and permit the film to remain in place until the sealant has completely cured.

PREPARE PREPACKAGED SEALANT INJECTION CARTRIDGE FOR USE AS FOLLOWS

**STEP 1**

WEAR SAFETY GLOVES AND GOGGLES.

**STEP 2**

HOLD CARTRIDGE, GRASP DASHER ROD AND PULL BACK APPROXIMATELY ONE INCH.

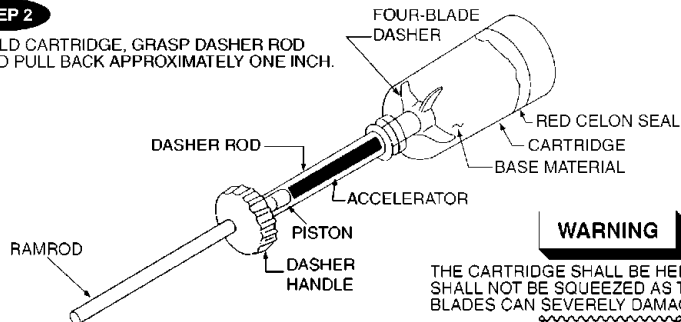
**NOTE**

USE EVEN PRESSURE, DO NOT USE FORCE, TAP, POUND OR JOLT RAMROD IF PISTON DOES NOT BREAK LOOSE READILY.

**STEP 3**

INSERT RAMROD INTO HOLLOW OF DASHER ROD, BREAK PISTON LOOSE AND INJECT ABOUT 1/3 OF THE CONTENTS INTO THE CARTRIDGE.

**NOTE**

THE RAMROD WILL BE FULLY INSERTED INTO THE DASHER ROD WHEN ALL OF THE ACCELERATOR HAS BEEN FORCED INTO THE CARTRIDGE.

**STEP 4**

REPEAT STEPS 2 AND 3 UNTIL ALL OF THE CONTENTS OF THE ROD ARE EMPTIED INTO THE CARTRIDGE. THEN REMOVE RAMROD.

**STEP 5**

REMOVE AND DISCARD RAMROD.

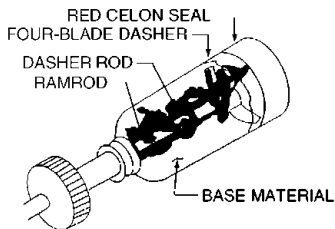
**STEP 6**

BEGIN MIXING OPERATION BY ROTATING DASHER ROD IN A CLOCKWISE DIRECTION, WHILE SLOWLY MOVING DASHER ROD TO FULL "OUT" POSITION.

**WARNING**

THE CARTRIDGE SHALL BE HELD FIRMLY, BUT SHALL NOT BE SQUEEZED AS THE DASHER BLADES CAN SEVERELY DAMAGE THE HAND.

**CAUTION**

THE MIXING MUST BE DONE BY A CLOCKWISE ROTATION OF THE DASHER ROD. COUNTERCLOCKWISE ROTATION MUST NOT BE USED BECAUSE THE FOUR BLADE DASHER INSIDE THE CARTRIDGE WILL UNSCREW FROM THE DASHER ROD.

**STEP 7**

CONTINUE CLOCKWISE ROTATION AND SLOWLY MOVE DASHER ROD TO FULL "IN" POSITION.

**CAUTION**

A MINIMUM OF FIVE FULL CLOCKWISE REVOLUTIONS MUST BE MADE FOR EACH FULLY "OUT" STROKE AND FOR EACH FULLY "IN" STROKE OF THE DASH ROD. MIX MATERIALS FOR THE NUMBER OF STROKES RECOMMENDED BY THE MATERIAL MANUFACTURER IN THEIR MIXING INSTRUCTIONS.

**STEP 8**

END MIXING ACTION WITH DASHER ROD IN FULL "OUT" POSITION.

**STEP 9**

WHILE HOLDING CARTRIDGE IN AN UPRIGHT POSITION, UNSCREW DASHER ROD BY GRIPPING DASHER BLADES IN AREA OF RED CELON SEAL AND TURNING DASHER ROD COUNTERCLOCKWISE.

**STEP 10**

SCREW NOZZLE INTO CARTRIDGE IF SEALANT FILLING GUN TO BE USED.

**STEP 11**

REMOVE RED CELON SEAL.

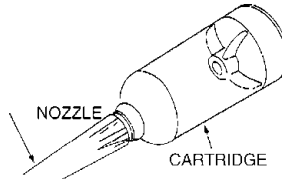
**STEP 12**

INSERT CARTRIDGE INTO APPLICABLE SEALANT GUN. REFER TO SEALANT GUNS.

Figure 12-7. Injection Style Semkit®

Table 12-2. Time Requirements for Sealants When Used at 75 °F (24 °C) &amp; 50% RH



Specification	Type or Class <sup>1</sup>	Assembly Time (Hr)	Tack-Free Time (Hr)	Approximate Time Until Usable (Hr)	Application Method(s)
 <p>MIL-PRF-81733, SEALING AND COATING COMPOUND, CORROSION INHIBITIVE 48</p>  <p>SAE AMS-S-8802, SEALING COMPOUND (POLYSULFIDE) 62</p>					
MIL-PRF-81733 (Supersedes MIL-S-81733)	I, CL 2-1/4 I-1/2 I-2 II, CL 1-1/6 II-1/4 II-1/2 II-2 II-4 III-1 IV-4 IV-12 IV-24 IV-40 IV-48	-- -- -- -- -- -- -- -- -- 8 24 48 120 168	4 CL1-16 CL2-8 CL1-24 CL2-16 4 CL1-8 CL2-1 CL1-16 CL2-2 CL1-24 CL2-12 32 8 40 120 180 600 1008	-- -- -- -- -- -- -- -- -- -- -- -- -- --	Brush Brush Brush Gun or spatula Gun or spatula Gun or spatula Gun or spatula Gun or spatula Spray Brush or spatula Brush or spatula Brush or spatula Brush or spatula Brush or spatula
SAE AMS-S-8802 (Supersedes MIL-S-8802)	A-1/2 A-1 A-2 B-1/2 B-1 B-2 B-4 C-12 C-20 C-80 C-96	-- -- -- -- -- -- -- 12 20 80 96	10 20 40 10 20 40 48 -- 96 120 --	40 55 72 30 55 72 90 -- -- -- --	Brush Brush Brush Gun or spatula Gun or spatula Gun or spatula Gun or spatula Brush or spatula Brush or spatula Brush or spatula Brush or spatula



Table 12-2. Time Requirements for Sealants When Used at 75 °F (24 °C) &amp; 50% RH - Continued















Specification	Type or Class <sup>1</sup>	Assembly Time (Hr)	Tack-Free Time (Hr)	Approximate Time Until Usable (Hr)	Application Method(s)	
	 					
	SAE AMS 3374, SEALANT, SILICONE			75		
	  					
	MIL-S-85420, SEALING COMPOUND, QUICK REPAIR, LOW TEMPERATURE CURING			53		
	   					
	SAE AMS-3277 (MIL-S-29574), SEALING COMPOUND, LOW TEMPERATURE CURING			61		
	   					
	MIL-A-46146, ADHESIVE/SEALANT, SILICONE RTV, NON-CORROSIVE, GROUP I/II/III, TYPE I OR GROUP I, TYPE II			19		
AMS 3374 (Supersedes MIL-S-38249)	/1 /2 /3 /4	1 - N/A 2 - 4 3- 4 4 - 1/2	-- -- -- --	6 24 6 2	14 days 7 days or 1 day @ 120 °F (49 °C) 14 days 7 days	Gun or spatula Gun or spatula Gun or spatula Gun or spatula
MIL-S-85420	Ty I, C1 A-1/6 Ty I, C1 B-1/6 Ty II, C1A-1/6 Ty II, C1B-1/6	-- -- -- --	2 (ST), 4 (LT) <sup>2</sup> 2 (ST), 6 (LT) <sup>2</sup> 2 (ST), 4 (LT) <sup>2</sup> 1-1/4 (ST), 4 (LT) <sup>2</sup>	4 (ST), 8 (LT) <sup>2</sup> 4 (ST), 8 (LT) <sup>2</sup> 4 (ST), 6 (LT) <sup>2</sup> 4 (ST), 6 (LT) <sup>2</sup>	Brush Gun or spatula Brush Gun or spatula	
AMS 3277 (MIL-S-29574)	A-1/4 A-1/2 A-2 B-1/4 B-1/2 B-2 C-4	-- -- -- -- -- -- 8	1 / 3 / 6 <sup>3</sup> 1.5 / 3 / 6 <sup>3</sup> 9 1 / 3 / 6 <sup>3</sup> 2 / 6 / 6 <sup>3</sup> 9	1.5 / 4 / 8 <sup>3</sup> 3 / 8 / 16 <sup>3</sup> 14 1.5 / 4 / 8 <sup>3</sup> 3 / 8 / 16 <sup>3</sup> 14 24	Brush Brush Brush Gun or spatula Gun or spatula Gun or spatula Brush or spatula	
MIL-A-46146	Gp I, Ty I Gp I, Ty II Gp II, Ty I Gp II, Ty II Gp III, Ty I Gp III, Ty II	-- -- -- -- -- --	5 5 5 5 5 5	-- -- -- -- -- --	Gun or spatula Pour Gun or spatula Pour Gun or spatula Pour	



Table 12-2. Time Requirements for Sealants When Used at 75 °F (24 °C) &amp; 50% RH - Continued

Specification	Type or Class <sup>1</sup>	Assembly Time (Hr)	Tack-Free Time (Hr)	Approximate Time Until Usable (Hr)	Application Method(s)
 SAE AMS 3255, TAPE, SEALING, POLYTETRAFLUOROETHYLENE <span style="float: right;">73</span>					
AMS 3255 - EPTFE Sealing Tape (Skyflex®) Av-DEC™ HT3935-7 & HT3000 Series Polyurethane Sealing Tapes AvDEC™ Injectable Polyurethane Sealants	Class 1	--	0	0	Peel and Stick
	Class 2	--	0	0	Peel and Stick
	--	--	0	0	Peel and Stick
	Self-Leveling™ Green, HT3326-5 Thixoflex™ Orange, TF2219	<20 (minutes)	45 (minutes) max	--	Gun with syringe
		<3 (minutes)	7 (minutes) max	--	Gun with syringe

<sup>1</sup> The number after the dash (-) indicates the room temperature working life of the sealant after it is mixed.

<sup>2</sup> (ST) = Standard Temperature of +75 °F (+24 °C); (LT) = Low Temperature of +45 °F (+7 °C).

<sup>3</sup> 1<sup>st</sup> # @ +75 °F (+24 °C); 2<sup>nd</sup> # @ +40 °F (+4 °C); 3<sup>rd</sup> # @ +20 °F (-7 °C)

**12.5.2 Storage Instructions.** When large quantities of sealants are used, such as for depot level maintenance operations, it may be advantageous to premix and freeze sealants to provide a ready supply of mixed sealants when they are needed. Store two-part kits and Semkit® package sealants according to instructions on the container. Store polysulfide sealants in a pre-mixed and frozen (PMF) form in a freezer at -40 °F (-40 °C) or below for retention of optimal application properties and shelf life. Polythioether sealants require extremely low temperature refrigeration at -80 °F (-62 °C) or below for optimal retention of application properties and shelf life. Thawing of PMF sealants can be accomplished in two ways. For ambient temperature thaw, place the PMF cartridge in a vertical position. Let stand at +70 °F to +80 °F (+21 °C to +27 °C) approximately 30 minutes. Dry any condensation from the exterior of the cartridge prior to use. For water bath thaw, place the PMF cartridge upright in a +120 °F (+49 °C) water bath for approximately 4 to 6 minutes. Upon removal from the bath, carefully dry the exterior of the cartridge before using.



MIL-PRF-81733, SEALING AND COATING COMPOUND, CORROSION INHIBITIVE 48

**12.5.3 Mixing MIL-PRF-81733, Type III Sprayable Sealant Coating.** The base component (Part B) of MIL-PRF-81733 Type III has a tendency to settle out during storage, so it requires thorough mixing with a standard paint shaker to obtain a uniform consistency before the addition of the accelerator component (Part A). The accelerator component (Part A) requires hand shaking or stirring with a wood stir paddle/stick in its container to obtain a uniform consistency before adding it to the base component (Part B). After both components, base and accelerator, have been stirred/mixed separately, add the proper amount of the accelerator to the base in its container and mix the combined materials, preferably with a paint shaker for 3 minutes in an upright position followed by 3 minutes in an inverted position for kits up to 1 gallon and for 5 to 10 minutes with an air driven agitator in a pressure pot for kits greater than 1 gallon. For proper application life and cure, the base and accelerator must be combined in the proper ratio and mixed prior to the addition of any thinner (solvents). After mixing, the sealant may be thinned for spraying to a viscosity

## TO 1-1-700

of 20 to 25 seconds in a No. 2 Zahn cup (reference TO 1-1-8) with a 20% to 30% by volume addition of a 50% by volume mixture of MEK conforming to ASTM D 740 and Toluene conforming to A-A-59107 and stirring for 2 minutes with an air driven agitator at 70 rpm.

## 12.6 SEALANT APPLICATION PROCEDURES.



SAE AMS 3166, SOLVENT, WIPING

71



A-A59281, SOLVENT, CLEANING

72



MIL-A-46106, ADHESIVE/SEALANT, SILICONE RTV, CORROSIVE

18



MIL-A-46146, ADHESIVE/SEALANT, SILICONE RTV, NON-CORROSIVE, GROUP I/II/III, TYPE I OR GROUP I, TYPE II

19



SAE AMS-3276 (MIL-S-83430), SEALING COMPOUND, INTEGRAL FUEL TANK

59

**WARNING**

When cleaning an area prior to applying a sealant, apply a small amount of solvent to a clean cloth, wipe the surface, and follow by wiping with a clean, dry cloth. Immediately after use, place used rags into an appropriate HAZMAT container, and then dispose of per local directives. This minimizes exposure of personnel to and release of solvent vapors into the environment.

**CAUTION**

- No RTV sealant which produces acetic acid such as those conforming to MIL-A-46106 shall be used on Air Force equipment unless required by the equipment specific repair manual. No RTV sealant shall be used in areas where exposure to fuels and oils will be encountered. If RTV sealants are required by the equipment specific repair manual, ensure that the sealant conforms to MIL-A-46146, Adhesives/Sealants, Silicone, RTV, Non-corrosive (for use on sensitive metals and equipment), and/or is listed in TO 1-1-691, Appendix A, as being a non-corrosive RTV silicone sealant.
- Do not use SAE AMS 3267 (MIL-S-8784) sealant in high temperature areas or for permanent structural installations. These sealants have no high temperature resistance and very low peel strength. Some typical uses of SAE AMS 3267 (MIL-S-8784) sealants include sealing floor panels and plates and fuel tank inspection plates.

**12.6.1 Cleaning.** If the surfaces have been contaminated following corrosion removal and surface treatment per instructions in Chapters 8 and 11 of this manual; clean the area with a clean CCC-C-440, Type I or II, Class 2 cheesecloth; an AMS 3819A, Class 2, Grade A cleaning cloth; or a CCC-C-46, Type I, Grade 7 non-woven cleaning cloth saturated with either A-A-59281, Type I or SAE AMS 3166 solvent. Begin at the top of the area to be sealed and work downward. Dry the surfaces immediately with a clean cloth. Do not allow solvent to evaporate from the surface because it will allow some or all of the oil, dirt, etc. to redeposit, making it impossible to remove with a dry cloth. Use a stiff bristle brush to clean around bolts, rivets, etc. Always use clean cloth as each new area is cleaned.

**NOTE**

- Always pour solvent on the cloth to avoid contaminating the solvent supply. Reclaimed solvents or soiled cleaning cloths shall not be used. After surface treatment, do not contaminate areas to be sealed with soiled hands or tools.
- See Appendixes A and B in TO 1-1-691 for procurement information on materials used for cleaning and masking.

**12.6.2 Masking.** To prevent sealant from contacting adjacent areas during application and smoothing out operations, the surrounding area not being sealed can be masked off with AMS-T-21595, Type I masking tape (see Figure 12-8). In cases where the tape is likely to remain in place for more than

2 days on items exposed to direct sunlight and where tape residue on the surface cannot be tolerated, use AMS-T-22085, Type II (3M Co. part No. 481 or 225) preservation and sealing tape. Masking tape is very useful during fillet sealing of exterior surface lap and butt seams.

**12.6.3 Adhesion Promoters.** In some cases, it may be necessary to improve the adhesion of sealants by the use of adhesion promoters. Adhesion promoters are solvents that contain additives which leave a residue on the surface after solvent evaporation to promote adhesion. To apply, clean the area per paragraph 12.6.1, brush or wipe the surface to be sealed with the liquid solution, and allow the treated surface to dry by evaporation without touching the treated areas for 30 minutes to an hour before applying sealant. If a polythioether sealant is to be applied over a polysulfide sealant, part No. PR-186 is recommended for use at the sealant interface. If the surface becomes contaminated or sealant is not applied within 2 hours after applying an adhesion promoter, reclean the area and reapply the adhesion promoter per the above instructions. Refer to TO 1-1-691 Appendix A for information relative to purchasing/ordering these adhesion promoters.

**12.6.4 Brush Spatula or Caulking Gun Application.** Prior to masking and sealing, prepare and clean the surface in accordance with paragraph 12.6.1.



TT-N-95, NAPHTHA, ALIPHATIC

66



Do not contaminate areas to be sealed with hands, tools, etc. after surface treatment and primer application.

- a. To prevent sealant from contacting adjacent areas during application and smooth out, outline the areas being sealed with masking tape (AMS-T-21595, Type I) so that each tape strip is 1/16 inch to 1/8 inch from the edge of butt seams and the upper surface edge of a lap seam and 1/4 inch to 3/8 inch from the lower surface edge of a lap seam. If tape residue on these surfaces is excessive, remove adhesive residues using TT-N-95 Aliphatic Naphtha. Masking may be very beneficial during fillet sealing of exterior surface lap seams and filling exterior surface butt seams.

- b. Apply sealant between the pieces of tape.
  - (1) Thick sealants may be applied with a non-metallic spatula or spreader to fillet seal lap seams or flush fill butt seams as shown in Figure 12-8. Avoid the entrapment of air. Work sealant into recesses by sliding the edge of the spatula firmly back over recesses. Smoothing will be easier if the non-metallic spatula is first dipped in water.
  - (2) Brushable sealants are applied with a brush and smoothed until the desired thickness is reached.

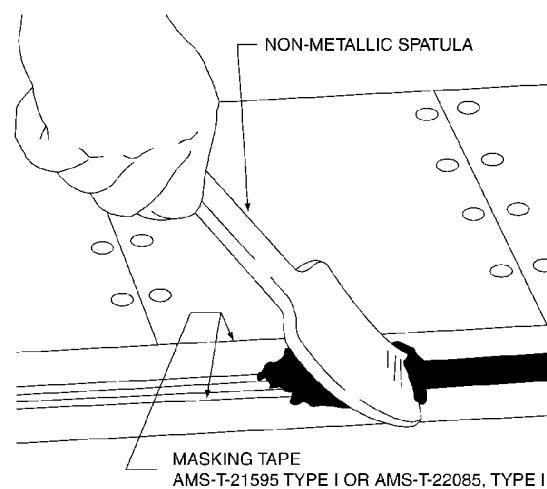

**Figure 12-8. Non-Metallic Spatula**

- (3) Thick sealants may be applied with a caulking gun, and if done carefully, will not usually require masking. This method is especially adaptable to filling seams or the application of form-in-place gaskets. On exterior surfaces where smoothness is required, masking is necessary to allow smoothing the sealant after application without smearing it onto surrounding surfaces.
- c. Remove masking tape after the sealant has been applied and before it begins to set. Cure time depends on the application life of the sealant materials used, the temperature, and the RH. When sealant no longer feels tacky, prime and topcoat as necessary and required by system specific technical data per application instructions in TO 1-1-8.

## TO 1-1-700

- d. Remove all uncured sealant residue by wiping the area with an SAE AMS 3819A, Class 2, Grade A or equivalent cleaning cloth wetted with a liquid product known as Sky Wash® distributed by AeroSafe Products Inc. and wiping dry with a clean, dry cloth of the same type.

**NOTE**

- MEK conforming to ASTM D740 may be used as an alternate solvent for cleaning up uncured sealant residues as long as it is not environmentally prohibited and the equipment SPM approves its use and requires it in system specific technical data.
- See Appendixes A and B in TO 1-1-691 for procurement information on materials used for cleaning and masking.

12.6.5 Spray Gun Application. Prior to masking and sealing, prepare surface in accordance with paragraph 12.6.1.



If any dirt or oil residues accumulate after conversion coating, clean thoroughly with solvent to ensure adequate adhesion of paint, primer, and sealant.

- a. Mask off adjacent areas with either MIL-PRF-121, Type I or II or MIL-PRF-131, Class 1 barrier material held in place with AMS T-21595, Type I masking tape to minimize overspray on adjacent areas.



MIL-PRF-81733, SEALING AND COATING COMPOUND,  
CORROSION INHIBITIVE 48

- b. Apply MIL-PRF-81733, Type III sprayable sealant in a solid, continuous pattern per the manufacturer's instructions and TO 1-1-8.

**NOTE**

The Dry Film Thickness (DFT) of spray sealant coatings shall be in the range of 3 to 5 mils (0.003 inch to 0.005 inch).

12.6.6 Peel and Stick Application: AMS 3255 EPTFE Skyflex® and Av-DEC® HT3935-7 and HT3000 Sealing Tapes. Prior to application, prepare surface in accordance with paragraph 12.6.1.



After surface treatment and any required primer application, do not contaminate areas to be sealed with soiled hands or tools as contamination prevents proper sealing tape adhesion.

- Examine faying surfaces to be sealed and build up any uneven areas on the equipment frame flange. Use Skyflex® part No. GUA-1003-1 compensation tape or a small piece of the same type of Skyflex® tape that will be used for AMS 3255 sealing tape applications and a small piece of the same type of Av-DEC™ tape that will be used for HT3935-7 and/or HT3000 sealing tape applications. This will create a level faying surface for panel sealing.
- Select the proper part No. sealant tape so that it will cover the full width of the faying surface to be sealed. Tape may be applied to either the equipment frame flange or to the panel faying surface.
- Measure and cut the required length of sealant tape.
- For corners, cut the ends of the tape at a 30 degree angle so that the sealant tape from the converging side will overlap by one-quarter to one-half inch. Do not fold the tape in corners as this will result in triple layer thickness.



Use care not to pull or stretch the sealant tape as it is applied. The stretched AMS 3255 EPTFE and Av-DEC® HT3000 tapes will retract even if clamped between faying surfaces, and the Av-Dec® HT3935-7 tapes will be reduced in thickness. In either case, inadequate sealing may result.

- Peel the non-stick backing paper off the sealant tape a little at a time as the tape is applied to the equipment frame flange or mating panel surface.

**NOTE**

- Applying a small amount of extra pressure to the upper surface of the sealant tape will cause the pressure sensitive adhesive to adhere better to the faying surface on which it is being applied, and it will create indentations/discoloration at the fastener holes allowing for easier location/identification. If done with Av-DEC® 3935-7 sealant tapes, it must be done before the non-stick backing paper is removed.
  - If an AMS 3255 sealant tape without a pressure sensitive adhesive backing has been ordered for use in areas where fluid exposure is expected, 3M Co. part No. Scotchgrip® 847 or 1099 plastic adhesive (see TO 1-1-691 Appendix A) may be used to hold the sealing tape in place during panel installation.
- f. After applying the full length of the sealant tape, run fingers back and forth on the upper surface of the sealant tape to press the tape against the equipment frame flange or the access panel surface to promote adherence of the adhesive.

**NOTE**

For Av-DEC® HT3935-7 sealant tapes, this must be done before the non-stick backing is removed.

- g. Puncture all fastener holes using an object with a sharp point such as an awl or a scribe.

**NOTE**

As fasteners are installed, the sealant material pushed into the fastener holes will help to seal against moisture intrusion.

- h. Install the access door/panel.



MIL-PRF-16173, COMPOUND, CORROSION PREVENTIVE

37



MIL-PRF-63460, LUBRICANT, CLEANER AND PRESERVATIVE 44

**NOTE**

No curing time is required. All fasteners should be wet installed with MIL-PRF-16173, Grade 4; MIL-PRF-63460 Corrosion Preventive Compound (CPC), or CPC material specified in the specific equipment system specific maintenance manual.

**12.7 SEALING OF SPECIFIC AREAS.**

**12.7.1 Faying Surface Sealing.** Faying surfaces are sealed by applying sealants to the connecting surfaces of two or more parts (see Figure 12-9). It is a very effective seal and should be used for all assembly or reassembly. When possible, it should be used in conjunction with fillet sealing. There are two types of faying surface seals: removable and permanent. Removable seals are used around access doors, removable panels, inspection plates, etc. A removable seal can be formed using a low adhesion sealant that adheres to both surfaces or by using a high adhesion sealant that adheres to one surface and a parting agent on the mating surface. Permanent seals are created using high adhesion sealants between permanently fastened structures. To create a permanent seal, coat either one or both mating surfaces with a high adhesion sealant before assembling the parts and then assembling them while the sealant is still wet. Apply enough sealant to force a bead to squeeze out along the joint after assembly, and also install all fasteners wet with the sealant. Assemble parts within the rated application life and/or assembly life of the sealant while taking into account the effects of temperature and humidity on these times.

## TO 1-1-700



MIL-PRF-81733, SEALING AND COATING COMPOUND,  
CORROSION INHIBITIVE 48



SAE AMS-S-8802, SEALING COMPOUND  
(POLYSULFIDE) 62



SAE AMS-3276 (MIL-S-83430), SEALING COMPOUND,  
INTEGRAL FUEL TANK 59

- a. For permanent structure, all faying surfaces, seams, and lap joints outside of fuel wet and high temperature areas shall be protected with MIL-PRF-81733, Type II or IV, Class 1 or 2, Grade A sealant. Apply the sealing compound to one or both surfaces and squeeze the part together to ensure the complete coating of the entire mating or faying surface. Excess material squeezed out shall be removed so that the fillet remains at the joint edges. The fillet width shall not be less than 1/4 inch. For seams, the sealant shall fill the seam entirely up to flush with the surface. Joint, joggle, or cavity areas which could hold water shall be filled with MIL-PRF-81733, Type II, Class 1 or 2, Grade A, SAE AMS-S-8802, Class B, or SAE AMS-3276, Class B sealant.



MIL-PRF-23377, TYPE I & II, PRIMER, EPOXY CHEMI-  
CAL AND SOLVENT RESISTANT 38



TT-P-2760, PRIMER, POLYURETHANE, ELASTOMERIC,  
HIGH SOLIDS 67

- b. If sealing is impossible because of mechanical or other factors, prime both surfaces with two coats of MIL-PRF-23377, Type I, Class C Epoxy Primer, or TT-P-2760, Type I, Class C Polyurethane Primer, per instructions in TO 1-1-8.

- c. Faying surfaces that are to be adhesive bonded shall be treated and processed as specified by the approved bonding procedure in the applicable system specific maintenance manual.



SAE AMS-3276 (MIL-S-83430), SEALING COMPOUND,  
INTEGRAL FUEL TANK 59



PR-1773, SEALING COMPOUND, LOW ADHESION,  
NON-CHROMATE CORROSION INHIBITORS 57

- d. On faying surfaces, seams, or joints which require disassembly for maintenance, either SAE AMS 3267 (MIL-S-8784) or part No. PR-1773 low adhesion sealant shall be used (part No. PR-1773 sealant contains non-chromate corrosion inhibitors).

**NOTE**

SAE AMS 3255 (Skyflex®) sealing tapes or Av-DEC® HT3935-7 and HT3000 sealing tapes may be used in lieu of the low adhesion curing type sealants in many removable joint areas requiring periodic disassembly for maintenance when approved by the equipment SPM.



MIL-PRF-81733, SEALING AND COATING COMPOUND,  
CORROSION INHIBITIVE 48



SAE AMS-S-8802, SEALING COMPOUND  
(POLYSULFIDE) 62



SAE AMS-3276 (MIL-S-83430), SEALING COMPOUND,  
INTEGRAL FUEL TANK 59



- e. On plastic components, the joints shall be suitably sealed and faired into the adjacent surfaces with MIL-PRF-81733, Type II or IV, Class 1 or 2, Grade A, SAE AMS-S-8802, Class B, or SAE AMS-3276 sealant, unless otherwise specified in the applicable system specific maintenance manuals, to stop the formation of pockets which will entrap moisture, dirt, etc.

#### NOTE

MIL-PRF-81733, Type II or IV, Class 1 or 2, Grade A sealant shall be used for rivets that require wet installation on plastic components.

**12.7.2 Fillet Sealing.** The fillet, or seam, as shown in Figure 12-10, is the most common type of seal. Fillet seals are used to cover structural joints or seams along stiffeners, skin butts, walls, and to seal around fittings and fasteners. This type of sealing is the most easily repaired. It should be used in conjunction with faying surface sealing and in place of it if the assembly sequence restricts the use of faying surface sealing.

**12.7.3 Injection Sealing.** This type of seal, as shown in Figure 12-11, is used primarily to fill voids created by structural joggles, gaps, and openings. **USE ONLY THOSE SEALANTS RECOMMENDED BY THE EQUIPMENT MANUFACTURER.** Force sealant into the areas using a sealant gun. This method is a means of producing a continuous seal where it becomes impossible to lay down a continuous

bead of sealant while fillet sealing. Clean the voids of all dirt, chips, burrs, grease, and oil before injection sealing.

**12.7.4 Fastener Sealing.** Figure 12-12 illustrates techniques used to seal different types of fasteners. Fasteners are sealed either during assembly or after assembly. Install them wet with sealant in accordance with requirements in the applicable system specific maintenance manual for fasteners in permanent structures. To seal during assembly, apply the sealant to the hole or dip the fastener into sealant, and install fastener while sealant is wet. For removable parts, coat the lower side of the fastener head only. Do not coat the hole or the fastener shank or threads, as this makes future removal almost impossible without damage to the part. To seal after assembly, cover the pressure side of the fastener with sealant after installation. Corrosion damaged areas in the countersinks around removable and fixed fasteners may be filled with the fastener in place. Cadmium coated fasteners that have been blasted or abraded during corrosion removal shall be primed in accordance with the applicable system specific maintenance manual and TO 1-1-8 and then coated with MIL-PRF-81733, Type I, Class 1 or 2, Grade A sealant.

**12.7.5 Form-In-Place (FIP) Gasket Sealant Repair.** After removal of all loose sealant material, thoroughly clean the area to be resealed per paragraph 12.6.1. Areas of the old seal to which new sealant will be added must be cleaned and abraded using an abrasive mat or abrasive cloth (see Appendix A in TO 1-1-691) to expose a clean, fresh surface.

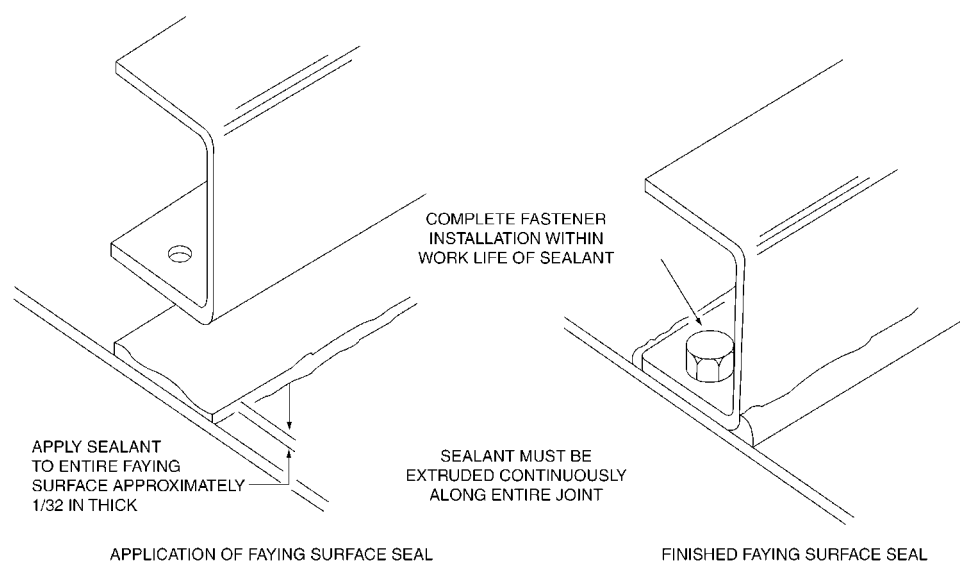

**Figure 12-9. Faying Surface Sealing**

## TO 1-1-700



MIL-PRF-81733, SEALING AND COATING COMPOUND,  
CORROSION INHIBITIVE 48



PR-1773, SEALING COMPOUND, LOW ADHESION,  
NON-CHROMATE CORROSION INHIBITORS 57



SAE AMS-3276 (MIL-S-83430), SEALING COMPOUND,  
INTEGRAL FUEL TANK 59

- a. Apply MIL-PRF-81733, Type II-1/2, Class I, Grade A, PR-1773, Class B-1/2, or SAE AMS-3276, Class B-1/2 sealant, preferably with a sealant gun. The new sealant should match the configuration of the removed sealant but should be of sufficient depth to ensure contact with the mating surface.



MIL-PRF-32033, LUBRICATING OIL, GENERAL  
PURPOSE, PRESERVATIVE (WATER-DISPLACING,  
LOW TEMPERATURE) 41



VV-P-236, PETROLATUM 68

- b. Apply a very thin film of MIL-PRF-32033 (VV-L-800), Oil or VV-P-236, Petrolatum, to the mating surface of the access door/panel and close and/or install the access door/panel. If installed with fasteners, lubricate them with the same material used on the door/panel mating surface, install 1/2 of the required fasteners (every other fastener), and torque to 1/2 to 3/4 of the specified torque for the assembly.
- c. Do not open or remove the door/panel for a minimum of 24 hours.

12.7.6 SAE AMS 3255 EPTFE (Skyflex®) and Av-DEC® HT3000 and HT3935-7 Sealing Tape Gasket Repair. In order to preserve seal integrity, it is necessary to inspect the sealant tape each time an access panel is removed.

**NOTE**

- The main function of the pressure sensitive adhesive backing on the SAE AMS 3255 (Skyflex®) sealant tape is to hold the EPTFE sealant tape in place during access door/panel assembly. The adhesive on one side of the Av-DEC® HT3000 sealant tape acts as a seal as well as holding the sealant tape in place. Peeling/delamination of the adhesive from the equipment frame flange or access door/panel requires replacement of the sealant tape if the tape is no longer located in the faying surface. Visually inspect sealant tape material for nicks, cuts, gouges and delamination/separation.

- Av-DEC® HT3935-7 sealing tape requires complete replacement each time an access door/panel sealed with it is removed as it has an adhesive on both sides. Scrape the old tape off with a plastic tool, and apply a new length of tape as done originally.
  - a. Cut and remove damaged section of sealant tape.
  - b. Measure and cut a new piece of SAE AMS 3255 (Skyflex®) or Av-DEC® HT3000 sealant tape approximately one inch longer than the removed section.
  - c. Peel the non-stick backing paper off and install a new section of sealant tape so it overlaps the previously installed sealant tape by one-quarter to one-half of an inch on each side of the repair site.

**NOTE**

Ends of the repair splice must overlap the existing sealant tape to ensure seal integrity. Use care not to pull or stretch the sealant tape patch as it is applied. The stretched AMS 3255 EPTFE and Av-DEC® HT3000 sealant tape patches will retract even if clamped between faying surfaces, and inadequate sealing may result.

- d. Once the sealant tape patch is applied, run fingers back and forth on the upper surface of the sealant tape patch to promote adherence of the adhesive.

**NOTE**

Applying a small amount of extra pressure to the upper surface of the sealant tape patch will cause the pressure sensitive adhesive to adhere better to the faying surface and overlapped areas of old sealant tape and it will create indentations/discoloration at the fastener holes allowing for easier location/identification.

- e. Puncture any affected fastener holes with a sharp pointed object such as an awl or a scribe.

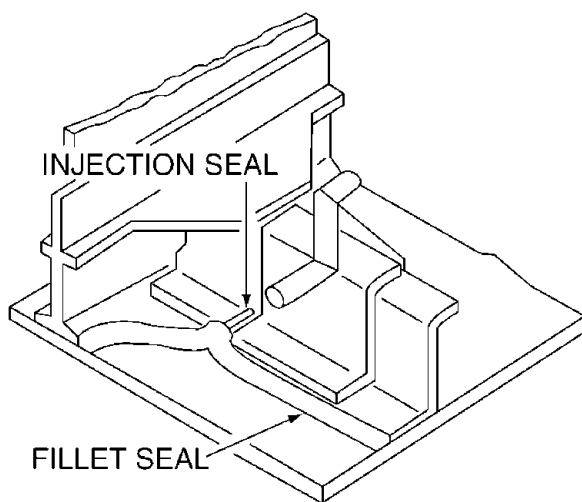

**Figure 12-10. Typical Fillet Seal**

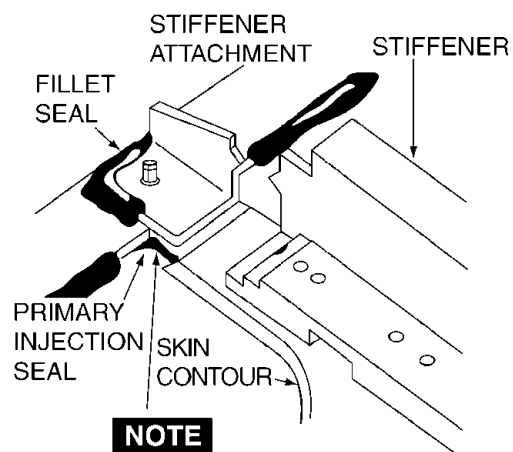

**NOTE**  
INJECTION SEAL JOINS  
FILLET SEAL ON EITHER SIDE  
TO PROVIDE CONTINUITY OF  
SEALANT

**Figure 12-11. Typical Injection Seal**

## TO 1-1-700

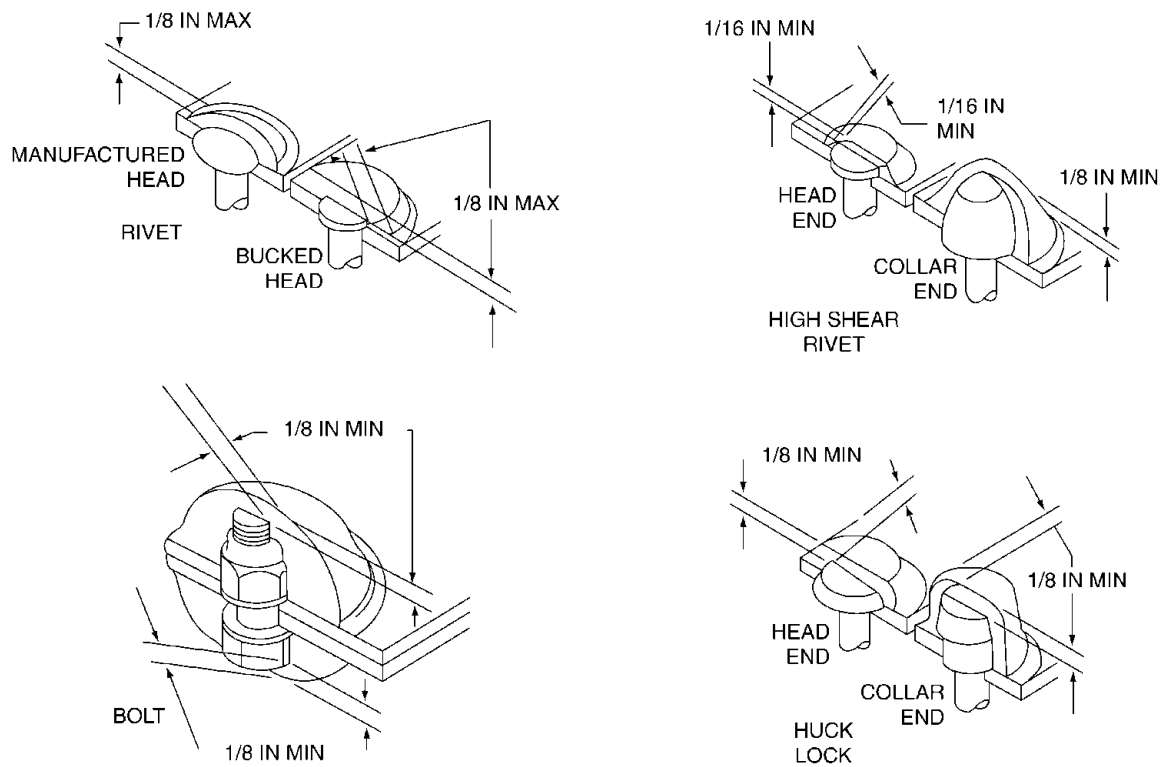

Figure 12-12. Typical Methods of Sealing Fasteners

**NOTE**

As fasteners are installed, the sealant material pushed into the fastener holes will help seal against moisture intrusion.

- f. Install access panel.



MIL-PRF-16173, COMPOUND, CORROSION PREVENTIVE

37



MIL-PRF-63460, LUBRICANT, CLEANER AND PRESERVATIVE

44

**NOTE**

No curing time is required. All fasteners should be wet installed with MIL-PRF-16173, Grade 4 Corrosion Preventive Compound (CPC); MIL-PRF-63460 CPC; or CPC material specified in the specific equipment system specific maintenance manual.

**12.7.7 External Structure.** If, during normal maintenance, it becomes necessary to remove and replace components (planks, skin, fasteners, fittings, etc.), they shall be sealed when reinstalled, even if they were not sealed originally. The only exception to this requirement is a temporary repair. See Figure 12-13, Figure 12-14 and Figure 12-15 for typical sealing methods.

**12.7.8 Depressions.** When the thickness of metal is reduced by more than 15 mils (0.015 inch) in the removal of corrosion damage, fill the depression with MIL-PRF-81733, Type II, Class 1 or 2, Grade A sealant after applying a chemical conversion treatment per Chapter 7.

**NOTE**

The above procedure does not apply to the use of SAE AMS 3255 EPTFE and Av-DEC® HT3935-7 or HT3000 sealing tapes; or to the use of SAE AMS-S-8802 (MIL-S-8802) sealant.

**12.7.9 Damaged Sealant.** Many areas on equipment are sealed either at the factory or by depots during rework. Fresh sealant shall be applied whenever the previously applied sealant is damaged. Remove the damaged sealant with a plastic scraper and, if necessary, prepare the metal surface in accordance with Chapters 8 and 11 of this manual. Slightly roughen a strip of the undamaged sealant approximately one inch wide around the boundary of the stripped area with an A-A-58054, Type I, Grade C Abrasive Mat and then clean the area per paragraph 12-6.1. Apply the new sealant by brush, sealant gun, or spatula and then smooth out the surface with a spatula as required. The new sealant should overlap onto the roughened area of the old sealant.

#### NOTE

- To assist with removal of damaged sealant, a liquid product known as Sky Restore® distributed by AeroSafe Products Inc. (see TO 1-1-691) may be applied to the damaged area with a non-metallic bristle brush, an SAE AMS 3819A, Class 2, Grade A or equivalent cleaning cloth, or a pump spray bottle and allowed to dwell for 15 to 50 minutes until the sealant is softened. A plastic scrapper may then be used to remove the damaged sealant. This material has a fairly obnoxious odor so it must be used either in a well ventilated area or personnel must wear an appropriate respirator in all confined areas.
- After the damaged sealant is scraped away, the area must be neutralized and cleaned with a liquid product known as Sky Wash® distributed by AeroSafe Products Inc. (see Appendix A in TO 1-1-691) applied in the same manner as above, scrubbed with the same type of brush or cloth as used above, and wiped dry
- Other tools useful for sealant removal are the 3M Co. SR Radial Bristle Discs and plastic SR Cutters mounted on a pneumatic drill motor and the Kell-Strom Toll Co. OZ7000 pneumatic sealant removal kit, a vibro gun with a set of plastic scrappers and OZ7006 manual sealant removal kit, a rubber palm support handle with a set of plastic scrappers. (see Appendix B in TO 1-1-691).



MIL-PRF-81733, SEALING AND COATING COMPOUND,  
CORROSION INHIBITIVE 48

**12.7.10 Extensive Repair.** If corrosion damage is so extensive that structural repair is necessary, all faying surfaces

between patches (or doublers) and skins shall receive a surface treatment per Section II of Chapter 5 in TO 1-1-691 before the repair parts are installed. Coat the faying surfaces with MIL-PRF-81733, Type IV, Class 1 or 2, Grade A sealant prior to installation of patch. Install all fasteners wet.



MIL-A-46146, ADHESIVE/SEALANT, SILICONE RTV,  
NON-CORROSIVE, GROUP I/II/III, Type I OR GROUP I,  
Type II 19



SAE AMS-3276 (MIL-S-83430), SEALING COMPOUND,  
INTEGRAL FUEL TANK 59



SAE AMS 3374, SEALANT, SILICONE 75

**12.7.11 High Temperature Areas.** In areas where the temperature is expected to rise above +250 °F (+121 °C), a one-part silicone sealant, MIL-A-46146, Type I or III or SAE AMS 3374, Type 1, 2, 3, or 4 silicone sealant, should be used for temperatures up to +400 °F (+204 °C). SAE AMS 3276 (MIL-S-83430) sealant may be used in areas that experience intermittent temperatures up to +360 °F (+182 °C). Application of these sealants is by spatula or sealant (caulking) gun per paragraph 12.6.4.



MIL-S-85420, SEALING COMPOUND, QUICK REPAIR,  
LOW TEMPERATURE CURING 53



SAE AMS-3277 (MIL-S-29574), SEALING COMPOUND,  
LOW TEMPERATURE CURING 61

**12.7.12 Low Temperature Curing.** When cold climates interfere with sealing operations by prolonging the sealant curing reaction, use MIL-S-85420 or SAE AMS 3277 (MIL-S-29574). For better adhesion, an adhesion promoter can be used; refer to paragraph 12-3.3. SAE AMS 3255 EPTFE and Av-DEC™ HT3935-7 or HT3000 sealant tape gasket materials

**TO 1-1-700**

may be used for low temperature sealing operations when specified in system specific technical data and/or is approved by the equipment SPM.

**12.8 STORAGE/SHELF LIFE CONTROL OF SEALANTS.**

All sealants have a specified shelf life. The date of manufacture and the shelf life are listed on each container. The shelf life is dependant on storing the sealant in its original, unopened container in an area where the temperature does not exceed 80 °F (27 °C). Sealants shall not be stored in areas where the temperature exceeds 80 °F (27 °C). Prior to use, sealant containers shall be inspected to determine if the material has exceeded its shelf life. If a sealant has exceeded its original shelf life then it shall not be used until the update testing has been performed. Sealants may be extended one-half of their original shelf life after passing the required tests. Updating may be repeated until sealant fails to pass testing. No sealant shall be used if it fails testing. Minimum update testing can be performed as follows.

- a. Select one kit of sealant from each manufacturer's batch of material to be tested for updating.

- b. Visually examine the content of each can in the kit. If the base polymer is lumpy or partially cured or cannot be mixed with the curing agent, dispose of the opened kit and all kits from that batch of sealant.
- c. If the kit can be blended to form a homogeneous mixture, determine whether the working time is suitable for the intended purpose by applying the mixture to a piece of clean scrap metal. If the working time is not acceptable, dispose of the opened kit and all others from that batch.
- d. If the working time is acceptable, the applied sealant shall be tested for proper cure time by periodically checking its hardness. The batch of sealant represented by applied test sealant can be extended one-half its original shelf life if it achieves approximately the same hardness as sealant from kits of another batch which are within their established shelf life.
- e. This updating process may be repeated until the sealant fails to pass any of the above tests.



## A. WHERE SKINS HAVE BEEN LIFTED

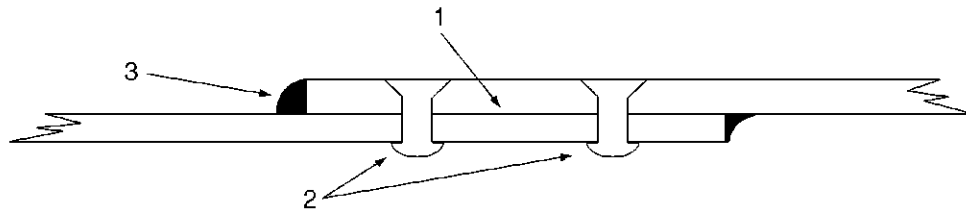

1. ASSEMBLE LAP JOINT WITH MIL-PRF-81733 IN FAYING SURFACES.
2. INSTALL FASTENERS WET WITH MIL-PRF-81733.
3. FILLET SEAL ALL EXTERNAL SEAMS WITH MIL-PRF-81733.
4. APPLY APPROPRIATE PAINT SYSTEM.

## B. WHERE JOINTS HAVE NOT BEEN OPENED

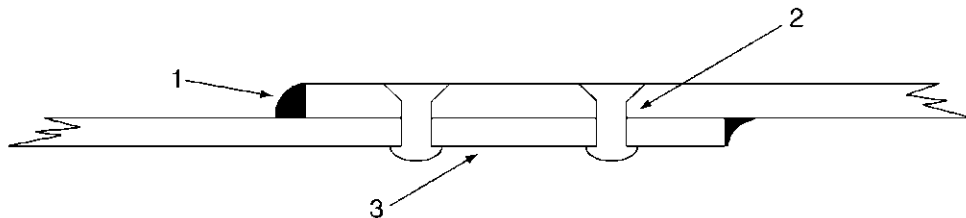

1. FILLET SEAL ALL EXTERNAL SEAMS WITH MIL-PRF-81733.
2. INSTALL FASTENERS WET WITH MIL-PRF-81733.
3. APPLY APPROPRIATE PAINT SYSTEM.

■ MIL-PRF-81733

Figure 12-13. Typical Lap Skin Sealing

TO 1-1-700

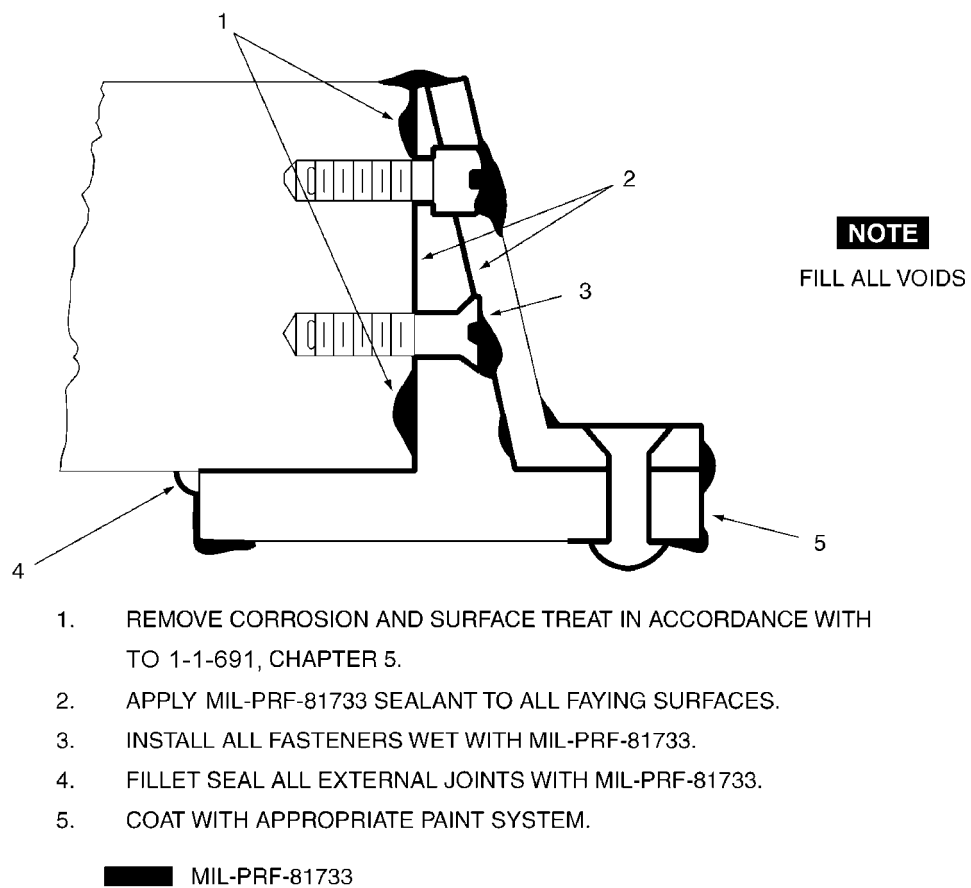

Figure 12-14. Sealing Procedures for Typical Fitting

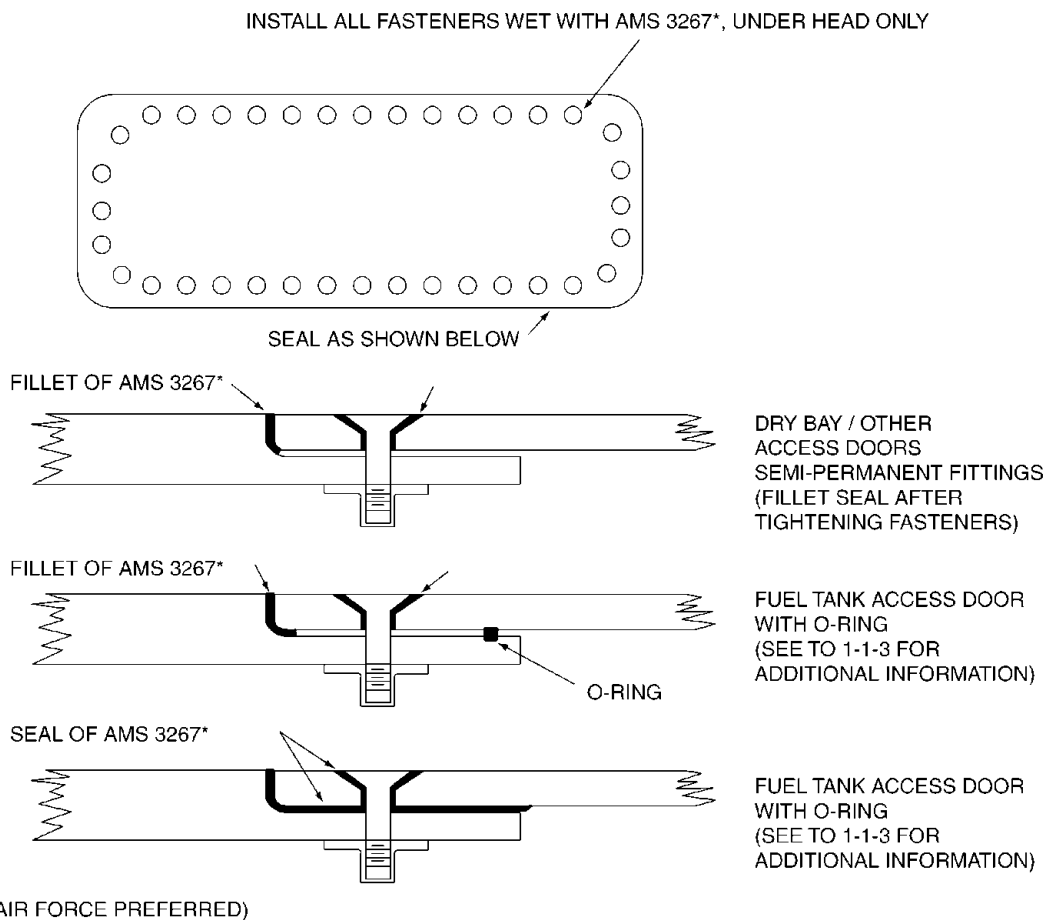

Figure 12-15. Sealing of Access Doors

