

TO 00-25-234

TECHNICAL MANUAL

**GENERAL SHOP PRACTICE REQUIREMENTS
FOR THE REPAIR, MAINTENANCE, AND
TEST OF ELECTRICAL EQUIPMENT**

BASIC AND ALL CHANGES HAVE BEEN MERGED TO MAKE THIS A COMPLETE PUBLICATION.

DISTRIBUTION STATEMENT A - Approved for public release; distribution is unlimited. PA Case Number 04-10-83. Submit recommended changes or problems with this Technical Order to 406 SCMS/GUEE, Robins AFB, GA 31098. Questions concerning technical content shall be referred to AFSC/LOEP.

Published Under Authority of the Secretary of the Air Force

22 SEPTEMBER 2013

CHANGE 1 - 23 MARCH 2014

TO 00-25-234

LIST OF EFFECTIVE PAGES

INSERT LATEST CHANGED PAGES. DESTROY SUPERSEDED PAGES.

NOTE The portion of the text affected by the changes is indicated by a vertical line in the outer margins of the page. Changes to illustrations are indicated by shaded or screened areas, or by miniature pointing hands.

Dates of issue for original and changed pages are:

Original0. . .22 September 2013 Change1.23 March 2014

TOTAL NUMBER OF PAGES IN THIS PUBLICATION IS 206, CONSISTING OF THE FOLLOWING:

Page No.	*Change No.	Page No.	*Change No.	Page No.	*Change No.
Title		1			
A		1			
i - vii		0			
viii Blank		0			
ix - xi		0			
xii Blank		0			
xiii - xv		0			
xvi Blank		0			
1-1 - 1-6		0			
2-1 - 2-5		0			
2-6 Blank		0			
3-1		0			
3-2 Blank		0			
4-1 - 4-68		0			
5-1		0			
5-2 Blank		0			
6-1 - 6-18		0			
7-1		0			
7-2		1			
7-3 - 7-4		0			
7-5 - 7-7		1			
7-8 - 7-18		0			
7-19 - 7-20		1			
7-21 - 7-33		0			
7-34		1			
7-35		0			
7-36		1			
7-37		0			
7-38 - 7-39		1			
7-40 - 7-43		0			
7-44 - 7-45		1			
7-46		0			
7-47 - 7-49		1			
7-50 - 7-53		0			
7-54 Blank		0			
8-1 - 8-14		0			
9-1		0			
9-2 Blank		0			
10-1		0			
10-2 Blank		0			
Glossary 1 - Glossary 8		0			
Index 1 - Index 5		0			
Index 6 Blank		0			

* Zero in this column indicates an original page.

TABLE OF CONTENTS

Chapter	Page	Chapter	Page
LIST OF ILLUSTRATIONS	vi	4.4	EQUIPMENT
LIST OF TABLES	vii	4.4.1	PERFORMANCE. 4-4
FOREWORD	ix	4.4.1.1	Deviations. 4-4
SAFETY SUMMARY	xiii	4.4.1.2	Performance Test Conditions 4-4
1 INTRODUCTION	1-1	4.4.2	Vibration and Shock Testing 4-4
1.1 MATERIALS AND PARTS	1-1	4.4.3	Vibration Testing 4-4
1.2 PARTS SUBSTITUTION	1-1	4.5	Shock Testing 4-4
1.3 ECONOMICAL REPAIR	1-1		MECHANICAL
1.4 RECOMMENDED TOOLS	1-1	4.5.1	FABRICATION 4-4
2 WORKMANSHIP	2-1	4.5.2	Chassis Construction. 4-4
2.1 GENERAL	2-1	4.5.2.1	Pins 4-5
2.2 WIRING.	2-1	4.5.2.2	Snug Fit 4-5
2.3 THERMAL BONDING.	2-1	4.5.2.3	Tight Fit 4-5
2.4 MECHANICAL BONDING.	2-1	4.5.3	Loose Fit 4-5
2.5 INSULATING	2-1	4.5.4	Rivets. 4-6
2.6 REPAIR AND REFINISHING	2-1	4.5.5	Eyelets 4-7
2.7 MARKING	2-1	4.5.6	Studs 4-7
2.8 CLEANING	2-1	4.5.7	Retaining Rings 4-7
2.9 HANDLING AND STORAGE.	2-2	4.6	Threaded Fasteners. 4-8
2.9.1 Protective Measures for Electrical		4.6.1	SAFETY WIRING AND SAFETY
Connectors	2-2	4.6.2	CABLING 4-11
2.9.2 Preparation for Shipment and		4.6.3	Material 4-11
Storage.	2-2	4.6.4	Twists Per Inch 4-11
2.9.3 Handling.	2-3	4.6.5	Double Twist Method 4-11
2.10 INSPECTION	2-5	4.6.6	Single Wire Method 4-11
3 SOLDERING.	3-1	4.6.7	Twisting With Pliers 4-12
3.1 GENERAL	3-1	4.6.8	Twisting With Special Tools. 4-12
4 GENERAL REPAIR	4-1	4.6.9	Tightness of Wire. 4-12
4.1 GENERAL	4-1	4.6.10	AN Connectors 4-12
4.2 SAFETY.	4-1	4.6.11	Split-Shell Assemblies. 4-14
4.2.1 Work Area	4-1	4.6.11.1	Solid-Shell Angle Plugs. 4-14
4.2.2 Rotating Machinery	4-1	4.6.11.2	V-Band Couplings 4-14
4.2.3 Chemicals	4-1	4.6.11.3	Pre-installation Checks 4-14
4.2.4 Electronics	4-3	4.6.11.4	Installation 4-14
4.2.5 Power Extension Cables	4-3	4.6.11.5	Gaskets. 4-15
4.3 EQUIPMENT CASES AND		4.7	Torque 4-15
PANELS.	4-3	4.8	Nuts. 4-15
4.3.1 Dents and Chips.	4-3	4.9	CLAMPS 4-16
4.3.2 Cracks and Holes.	4-3	4.9.1	WELDING 4-18
4.3.3 Connectors	4-3	4.9.2	WIRING. 4-18
		4.9.3	Type of Wire. 4-18
		4.9.4	Protection 4-18
		4.9.5	Marking 4-18
		4.10	Permanent Splicing. 4-19
		4.10.1	Emergency Splicing 4-19
		4.10.2	SHIELDED AND COAXIAL
		4.10.3	CABLE 4-21
		4.10.4	Removing Insulation. 4-21
			Connector Termination 4-21
			Grounding Sheath Termination 4-23
			Attaching Pigtail Wires to Cable
			Sheath 4-26

TABLE OF CONTENTS - CONTINUED

Chapter		Page	Chapter		Page
4.10.5	Emergency Splice	4-27	4.19.7	Zinc and Zinc Plated Parts	4-47
4.10.6	Insulation Repair	4-28	4.20	FUNGUS PREVENTION	4-47
4.10.7	Stripping Coaxial Cable with Single Conductor Shield	4-28	4.21	PRESSURIZATION TEST	4-47
4.11	CABLE BINDING AND LACING	4-28	4.22	MARKING AND IDENTIFICATION	4-47
4.11.1	Cable Lacing	4-28	4.23	TROUBLESHOOTING	4-48
4.11.2	Self-clinching Cable Straps	4-31	4.24	REPLACEMENT AND REPAIR OF PARTS	4-48
4.11.3	Cable Strap Installation	4-32	4.24.1	Fuses	4-48
4.12	HIGH TEMPERATURE PRES- SURE-SENSITIVE TAPE	4-33	4.24.2	Fuse Holders	4-54
4.12.1	Spot Tying	4-33	4.24.3	Lamps	4-54
4.12.2	Spot Tying with Nylon Straps	4-33	4.24.4	Resistors	4-54
4.13	CRIMPED ELECTRICAL CONNECTIONS	4-34	4.24.5	Capacitors	4-54
4.13.1	Types of Solderless Lugs	4-34	4.24.6	Inductors and Transformers	4-54
4.13.1.1	Pre-insulated Terminal Lugs	4-34	4.24.7	Relays	4-55
4.13.1.2	Uninsulated Terminal Lugs	4-34	4.24.8	Meters	4-55
4.13.2	Crimping Tools	4-35	4.24.9	Electron Tubes, General	4-55
4.13.2.1	Hand Tools	4-35	4.24.10	Cathode Ray Tubes	4-57
4.13.2.2	Power Tools	4-36	4.24.11	Semiconductor Devices	4-58
4.13.3	Crimping Procedure	4-36	4.24.12	MIL-C-25955 Connectors, MIL-S- 24251/3 Series	4-60
4.13.4	Crimp Inspection	4-36	4.24.13	Power Cords and Plugs	4-62
4.14	WIRE WRAPPED ELECTRICAL CONNECTIONS	4-36	4.24.14	Controls and Switches	4-63
4.14.1	Use	4-36	4.24.15	Vibration Isolators	4-63
4.14.2	Procedure	4-36	4.25	COMPONENT SUBSTITUTION	4-64
4.15	BOLTED ELECTRICAL CONNECTIONS	4-37	4.25.1	Fuses	4-64
4.16	INSULATING MATERIALS	4-37	4.25.2	Resistors	4-64
4.16.1	Coatings	4-37	4.25.3	Capacitors	4-65
4.16.2	Standard Insulation Tubing	4-37	4.25.4	Switches	4-65
4.16.3	Heat-Shrinkable Tubing	4-38	4.25.5	Solid-State Devices	4-65
4.16.4	Plastic Tape	4-39	4.25.6	Electron Tubes	4-65
4.17	POTTING OF CONNECTORS	4-40	4.25.7	Lamps	4-65
4.18	CLEANING PROCEDURES	4-42	4.25.8	Neon Lamps	4-66
4.18.1	Moderate Contamination	4-42	4.26	REPAIR OF ELECTRICAL CON- TACT STRIPS	4-66
4.18.2	Ultrasonic Cleaning	4-43	4.26.1	Description	4-66
4.18.3	Aerosol Cleaners	4-45	4.26.2	Areas of Use	4-66
4.18.4	Other Cleaning Techniques	4-45	4.26.3	Problems	4-66
4.18.5	Cleaning AN Connectors	4-45	4.26.4	Missing or Bent Contacts	4-66
4.18.6	Cleaning Group A and Group B Components	4-46	4.26.5	Manufacturers of Preformed Finger Stock	4-67
4.18.7	Capacitor Leakage	4-46	4.26.6	Mounting of Finger Stock	4-67
4.18.8	Precious Metal Contacts	4-46	4.26.7	Plating	4-67
4.19	CORROSION PREVENTIVE TREATMENTS	4-46	4.26.8	Assembly of Cavity Resonators	4-68
4.19.1	Equipment Exteriors	4-46	4.27	REPAIR OF WAVEGUIDE	4-68
4.19.2	Connectors	4-46	4.27.1	Cure Cycle	4-68
4.19.3	Aluminum Alloy Parts	4-46	5	PRINTED CIRCUIT BOARD REPAIR	5-1
4.19.4	Ferrous Alloys	4-46	5.1	GENERAL	5-1
4.19.5	Cadmium Plated Parts	4-47	6	PROTECTIVE COATINGS	6-1
4.19.6	Magnesium and Magnesium Alloys	4-47			

TABLE OF CONTENTS - CONTINUED

Chapter		Page	Chapter		Page
6.1	GENERAL	6-1	7.2	REFERENCES	7-1
6.2	SPECIAL TOOLS	6-1	7.3	SUMMARY OF ESD	
6.3	SPECIAL MATERIALS	6-1		PRINCIPLES	7-2
6.4	SAFETY PRECAUTIONS.	6-2	7.3.1	Static Electricity.	7-2
6.4.1	Work Area	6-2	7.3.2	Sources of Static Electricity.	7-2
6.4.2	Rotating Machinery	6-2	7.3.3	ESD Parameters.	7-3
6.4.3	Chemicals	6-2	7.3.4	Failure Mechanisms	7-4
6.4.4	Electronics	6-2	7.3.5	Failure Types.	7-4
6.5	REPAIR SEQUENCE.	6-2	7.3.5.1	Catastrophic	7-4
6.6	IDENTIFICATION OF		7.3.5.2	Intermittent	7-4
	COATING.	6-2	7.3.5.3	Latent.	7-4
6.6.1	Preliminary Identification.	6-2	7.3.6	Common ESD Misconceptions	7-5
6.6.2	Types of Coatings	6-3	7.4	ESD SUSCEPTIBILITY	7-5
6.6.3	Identification Chart.	6-3	7.4.1	Susceptible Items	7-5
6.6.4	Inspection	6-3	7.4.1.1	Discrete Parts	7-5
6.6.5	Ultraviolet Fluorescence	6-3	7.4.1.2	Circuit Boards, Modules and	
6.6.6	Acetone Test	6-3		Assemblies	7-6
6.6.7	Fingernail Test.	6-4	7.4.2	When Does ESD Susceptibility	
6.6.8	Burn Test	6-4		Stop	7-6
6.6.9	Color Test 1	6-6	7.4.3	ESD Sensitivity Defined	7-6
6.6.10	Color Test 2	6-6	7.5	FRAMEWORK OF ESD	
6.6.11	Color Comparison	6-6		CONTROL	7-6
6.7	REMOVAL OF COATING	6-7	7.5.1	Work Area ESD Control	
6.7.1	Polyurethane and Epoxy	6-7		Surveys	7-6
6.7.2	Parylene	6-8	7.5.2	ESD Control Strategies	7-6
6.7.3	Acrylic	6-10	7.5.3	Conductive/Static Dissipative/Non-	
6.7.4	Silicone	6-10		Charge Generating Materials	7-7
6.8	RECOATING REPAIRED		7.5.4	ESD Control Products.	7-7
	AREAS	6-10	7.5.4.1	Static Control Workstations (Refer-	
6.8.1	Washing of Boards	6-11		ence MIL-PRF-87893)	7-7
6.8.2	Polyurethane and Epoxy Coated		7.5.5	Principle Components	7-7
	Boards	6-11	7.5.5.1	Permanent Static Control	
6.8.3	Parylene Coated Boards	6-12		Workstation	7-7
6.8.4	Acrylic Coating	6-13	7.5.5.2	Static Control Workstation (with	
6.8.5	Silicone Coated Boards.	6-14		cushioned work surface)	7-8
6.9	CONFORMAL COATING OF CE-		7.5.5.3	Static Control Workstation (with	
	RAMIC PRINTED CIRCUITS			rigid work surface).	7-10
	(CPC'S)	6-17	7.5.5.4	Portable Static Control	
6.9.1	Preparing Coating Material	6-17		Workstation	7-10
6.9.2	Application of Coating	6-17	7.5.5.5	Personnel Wrist Strap	7-10
6.9.3	Curing the Coating.	6-17	7.5.5.6	Common Point Ground Systems	
6.9.4	Cleanup	6-17		(CPGS).	7-10
6.10	PROTECTIVE COATING		7.5.5.7	Bench Top Ionizers.	7-11
	ACCEPTANCE	6-17	7.5.5.8	Static Dissipative Gloves and Finger	
6.11	VARNISH-TYPE COATINGS	6-18		Cots	7-11
6.11.1	Sealing	6-18	7.5.5.9	Static Dissipative Flooring	
6.11.2	High-Voltage Circuits	6-18		System	7-11
			7.5.5.10	Grounded Electrical Tools and	
				Equipment.	7-12
7	ELECTROSTATIC DISCHARGE		7.5.5.11	Relative Humidity	7-12
	CONTROL	7-1	7.5.5.12	Computer Keyboard Ground	
				Strips	7-12
7.1	GENERAL	7-1	7.5.5.13	ESD Control Product and Ground	
7.1.1	Purpose	7-1		Integrity Test Equipment	7-12
7.1.2	Scope	7-1	7.5.5.15	Marking	7-17
7.1.3	Applicability	7-1			

TABLE OF CONTENTS - CONTINUED

Chapter		Page	Chapter		Page
7.5.6	Grounding.	7-34	7.8.10	Workstation Grounding Test	
7.5.6.1	ESD Ground Measurement Reference Point.	7-34	7.8.11	Procedures	7-52
7.5.6.2	Equipment Required For ESD		7.8.12	Solder Gun or Iron Test	
7.5.6.3	Ground Integrity Checks	7-34		Procedures	7-52
	ESD Control Workstation Grounding (Indoor Powered Operations)	7-34		Compressed Air, Hot Air Blowers, Dry Nitrogen and Vacuum Nozzle Ground Test Procedures.	7-53
7.5.7	Grounding Point.	7-36	8	FRONT PANEL REPAIR.	8-1
7.5.7.1	ESD Control Workstation Grounding (Building Steel)	7-36	8.1	GENERAL	8-1
7.5.7.2	Storage Cabinets and Static Dissipative Floor Grounding	7-38	8.2	TYPES OF FRONT PANELS	8-1
7.5.7.3	Portable ESD Control Workstation and Personnel Wrist Strap Grounding (Remote Indoor or Outdoor Operations)	7-38	8.2.1	Exterior Lighted Front Panels.	8-1
7.5.7.4	Use of Ground Fault Interrupters (GFI) for ESD Control Purposes	7-38	8.2.2	Illuminated Front Panels	8-1
7.5.7.5	Personnel Safety	7-38	8.3	TOOLS AND ACCESSORIES	8-1
7.5.7.6	Other Grounding Requirements	7-39	8.4	MATERIALS	8-1
7.5.8	Cleaning of ESDS Items	7-39	8.5	GENERAL PRECAUTIONS	8-1
7.6	OPERATING PROCEDURES	7-40	8.6	CLEANING	8-1
7.7	WORK AREA ESD CONTROL SURVEYS	7-44	8.7	INSPECTION	8-2
7.7.1	Background.	7-45	8.8	INITIAL TESTING (FRONT PANEL REMOVED FROM LRU)	8-3
7.7.2	General.	7-45	8.9	TROUBLESHOOTING.	8-3
7.7.3	Performing Work Area ESD Control Surveys	7-45	8.10	REPAIR OF CRACKED OR BROKEN PANELS.	8-3
7.7.4	ESD Control Product Requirements.	7-45	8.11	REPAIR OF BROKEN CORNERS	8-3
7.7.4.2	Static Control Workstations	7-45	8.12	REPAIR OF BROKEN BUSS WIRE.	8-4
7.7.4.3	Test Benches	7-45	8.13	REPLACEMENT OF FAULTY BULBS	8-7
7.7.4.4	Wrist Straps	7-46	8.14	REMOVAL/REPLACEMENT OF FILTERS/ REFLECTORS	8-8
7.7.4.5	Unique Situations.	7-46	8.15	FILLING EXCAVATION	8-8
7.7.5	Work Area ESD Control Checklist.	7-48	8.16	REMOVAL, REPLACEMENT OF FILTER BRACKET, PILE FASTENERS AND ANNUNCIATORS	8-9
7.8	PERIODIC TESTING OF ESD CONTROL PRODUCTS.	7-49	8.17	SANDING	8-10
7.8.1	Work Surface Test Procedures	7-49	8.18	MIXING AND PAINTING PRIMER INK	8-10
7.8.2	Storage Cabinet and Shelf Test Procedures	7-49	8.19	MIXING AND PAINTING BACKGROUND INK	8-10
7.8.3	Flooring Test Procedures	7-50	8.20	SILKSCREENING	8-10
7.8.4	Wrist Strap Test Procedures	7-50	8.21	CLEAR EPOXY INK APPLICATION	8-11
7.8.5	Footwear Test Procedures	7-51	8.22	WIRING BULB LOCATION STENCILING	8-11
7.8.6	Test Procedures for Bench Top Electrical Ionizers	7-51	8.23	CONNECTOR PLUG REMOVAL REPLACEMENT.	8-12
7.8.7	Seating Test Procedures.	7-52	8.24	FINAL TESTING.	8-13
7.8.8	Shielding Bag Test Procedures	7-52			
7.8.9	Conductive/Static Dissipative Finger Cots and Gloves.	7-52			

TABLE OF CONTENTS - CONTINUED

Chapter		Page	Chapter		Page
9	FLEXIBLE PRINTED CIRCUIT REPAIR PROCEDURES	9-1	10.1.1	Counterfeit Materiel	10-1
			10.1.2	Suspect Counterfeit Materiel	10-1
9.1	GENERAL	9-1		GLOSSARY	Glossary 1
10	SUSPECTED COUNTERFEIT PARTS OR MATERIAL	10-1		INDEX	Index 1
10.1	GENERAL	10-1			

LIST OF ILLUSTRATIONS

Number	Title	Page	Number	Title	Page
2-1	Chassis-Type Electronic Assembly, Protective Packaging	2-4	4-36	Starting a Cable Lace	4-30
2-2	Circuit Board-Type Electronic Assembly, Protective Packaging	2-4	4-37	Cable Stitching.	4-30
2-3	Plug-In Type Electronic Assembly, Protective Packaging	2-5	4-38	Cable Lace Termination.	4-30
4-1	Typical Scribe	4-4	4-39	Cable Branching.	4-30
4-2	Typical Chassis Punch.	4-5	4-40	Strap Configuration.	4-31
4-3	Application of Dowel Pin	4-5	4-41	Installing Self-Clinching Plastic Cable Straps	4-32
4-4	Application of Tapered Pins	4-5	4-42	MS90387 Adjustable Hand Tools for Installing Self-Clinching Plastic Tiedown Straps	4-33
4-5	Typical Drive Pins and Spring Pins	4-5	4-43	Cable Lace, Spot Tie.	4-33
4-6	Clevis Pin	4-6	4-44	Nylon Strapped Spot Tie	4-34
4-7	Countersunk and Skin-Dimpled Rivet Holes	4-6	4-45	Solderless Terminal Lugs.	4-35
4-8	Bucking Bar Recess	4-6	4-46	Pre-Insulated Terminal Lug Cutaway	4-36
4-9	Rivet Head Criteria.	4-7	4-47	Insulating Sleeves.	4-36
4-10	Properly and Improperly Set Rivets.	4-7	4-48	Inserting Aluminum Wire Into Aluminum Terminal Lugs	4-37
4-11	Acceptable and Unacceptable Eyelets	4-7	4-49	Hand Crimping Tools for Pre-Insulated Terminals	4-38
4-12	Typical Studs and Terminals.	4-8	4-50	Hand Crimping Tool, Aluminum Terminals	4-39
4-13	Typical Retaining Rings.	4-8	4-51	Power Crimping Tools.	4-39
4-14	Tapped Hole Specifications	4-9	4-52	Inserting Terminal Lug Into Hand Tool	4-40
4-15	Anchor Nuts, Clinch Nut, and Plug Nut.	4-10	4-53	Wire Wrapping Tool in Use	4-41
4-16	Typical Lockwashers.	4-12	4-54	Wire Wrapping Technique	4-42
4-17	Double Twist Safety Wiring	4-13	4-55	Typical Bolted Connections	4-43
4-18	Single Wire Method	4-13	4-56	Electric Hot-Air Gun.	4-43
4-19	Use of Wire Twister	4-14	4-57	Spare Wires for Potted Connector	4-43
4-20	V-Band Coupling Safety Wiring Techniques	4-16	4-58	Cleaning Connector Prior to Potting	4-44
4-21	Safety Wiring AN Connectors.	4-17	4-59	Filling and Curing Potted Connector	4-44
4-22	Safety Wiring AN Connector to Structure	4-17	4-60	Installation of O-Ring on Potted Connector	4-44
4-23	Safety Wiring AN Split-Shell Assembly Screws	4-18	4-61	Slow-Blow Fuse.	4-49
4-24	Typical Clamps	4-18	4-62	Military Fuse Designations.	4-56
4-25	Pre-Insulated Permanent Copper Splices	4-19	4-63	Correct Wiring of Instrument-Type Fuse Holder	4-57
4-26	Terminal Lug Barrel Splice	4-21	4-64	Correct Wiring for Fuse Holders Containing Indicator Lights	4-59
4-27	Splicing Broken Wire by Soldering	4-21	4-65	Wiring Diagrams For Indicator Type Fuse Holders.	4-61
4-28	Shop Aids for Stripping Insulation from Coaxial Cables.	4-22	4-66	Repair of Power Cords	4-63
4-29	Attaching Improved N Connectors to Coaxial Cable	4-24	4-67	Power Cord Assembly.	4-64
4-30	Grounding Sheath Termination for Shielded Wire	4-25	4-68	Acceptable and Unacceptable Control Knob Damage	4-66
4-31	Soldered On Pigtail Preparation	4-27	6-1	Flow Diagram for Identification of MIL-I-46058 Conformal Coatings.	6-5
4-32	Common-Point Pigtail Splice	4-27	6-2	Conformal Coating Fillet	6-6
4-33	Several Shields in One Set of Sleeves	4-27	6-3	Fingernail Test	6-6
4-34	Typical Cascading Pigtails	4-29			
4-35	Braid Dead-Ending	4-29			

LIST OF ILLUSTRATIONS - CONTINUED

Number	Title	Page	Number	Title	Page
6-4	Color Test 2 Setup	6-9	7-6	Bench Top Ionizer Positioning	7-11
6-5	Removing Polyurethane Coating from Lead	6-9	7-7	First Touch Installation Procedures	7-13
6-6	Removing Polyurethane Coating or Fillets	6-9	7-8	MIL-STD-1285 Symbol	7-17
6-7	Removing Coatings and Fillets from Axial Components	6-11	7-9	ESD Attention Label/No Further Packag- ing Required	7-18
6-8	Drying or Curing Schedule for Coating Material Applied Shortly After Mixing	6-15	7-10	ESD Control Label/ESDS Item Packages (MIL-STD-129)	7-18
6-9	Drying or Curing Schedule for Coating Material Applied Near End of Work Life	6-16	7-11	ESD Caution Label/Off Base Transport Items (MIL-STD-129)	7-19
7-1	Reasons for Device Failure Due to ESD	7-4	7-12	Typical Electrical AC Outlet	7-34
7-2	Dielectric Failure in 3N157 MOSFET at 5000X	7-5	7-13	Typical Service Entrance	7-35
7-3	Permanent Static Control Workstation . . .	7-8	7-14	Flow Chart for ESD Control Workstation Grounding	7-37
7-4	Static Control Workstation (work cush- ioned or rigid work surface on an exist- ing work bench)	7-9	7-15	Typical ESD Protective Area Sign	7-43
7-5	Portable Static Control Workstation	7-9	8-1	Typical Stencil/Diagram	8-5
			8-2	Cracked Panel Repair	8-6
			8-3	Clinched Splice	8-8
			8-4	Typical Bulb Insert	8-8
			8-5	Buss Wire Connection	8-13
			8-6	Typical Excavated Plug	8-13
			8-7	Front Panel Mold	8-14

LIST OF TABLES

Number	Title	Page	Number	Title	Page
1-1	Recommended Tools	1-1	6-2	Repair Sequence	6-2
4-1	Recommended Materials	4-2	6-3	Color Test and Identification of Conformal Coatings	6-7
4-2	Pre-Insulated Copper Splices and Crimp- ing Tools	4-19	6-4	Coating Repair Process	6-10
4-3	Shielded Wire Terminations, Inner Sleeves	4-25	6-5	Polyurethane Recoat System	6-12
4-4	Shielded Wire Terminations, Outer Sleeves and Installing Tools	4-25	7-1	Typical Sources of Static Electricity	7-2
4-5	Self-Clinching Plastic Cable Straps and Installation Tools	4-31	7-2	Typical Electrostatic Voltages Generated by Personnel	7-3
4-6	Typical Heat-Shrinkable Tubing Sizes . . .	4-39	7-3	ESD Protective Equipment	7-19
4-7	Cleaning Moderately Contaminated Devices	4-45	7-4	Effects of Electrical Current on Humans (Reference MIL-STD-454)	7-39
4-8	Types of Organic Solvents	4-45	7-5	Summary of ESD Periodic Testing Time Intervals	7-44
4-9	Cross Reference, Military and Commercial Fuses	4-49	8-1	Equipment Used for Front Panel Repair	8-1
4-10	Limitations for CRT Dead Spots	4-57	8-2	Consumable Materials Required for Front Panel Repair	8-2
6-1	Special Materials for Conformal Coating	6-1			

FOREWORD

1 PURPOSE.

This technical order establishes standard shop practices for repair, maintenance, and test of electronic/electric equipment, and is the authorizing document for maintenance and replacement procedures where authorized procedures are unavailable. The purpose of this technical order is to provide the uniform criteria and basic work specifications required to process electronic/electric equipment when applicable directives are unavailable.

2 SCOPE.

The provisions contained herein are applicable to Air Force and contractual personnel engaged in repair, maintenance, or test of Aerospace Electronic/Electric Equipment.

NOTE

- With the exception of Chapter 7, the procedures and criteria contained in this technical order are general and do not take precedence over specific procedures and criteria outlined in handbooks and technical orders associated with specific equipment.
- In the overhaul of electronic components manufactured prior to the inception of NASA standards, May 1968, solder connectors of good mechanical and electrical integrity, conforming to the standards to which they were originally subjected, shall be deemed acceptable; unless these electrical connectors require rework due to troubleshooting, replacement of parts, wires, etc., at which time they shall conform to the present TO 00-25-234 standard.

1	Introduction
2	Workmanship
3	Soldering
4	General Repair
5	Printed Circuit Board Repair *
6	Protective Coatings
7	Electrostatic Discharge Control
8	Front Panel Repair
9	Flexible Printed Circuit Repair Procedures *
10	Suspected Counterfeit Parts or Materiel

* See also TO 00-25-259

3 ABBREVIATIONS.

All abbreviations used in this manual are in accordance with ASME Y14.38, Abbreviations and Acronyms for Use on Drawings and Related Documents.

AF	Air Force
AFTO	Air Force Technical Order
CAGE	Commercial and Government Entity
CFE	Contractor Furnished Equipment
DoD	Department of Defense
GFE	Government Furnished Equipment
in.	Inch or Inches
No.	Number
PN	Part Number
REF	Reference

4 RELATED PUBLICATIONS.

The following publications contain information in support of this technical manual.

List of Related Publications

Number	Title
AFI 21-101	Aircraft and Equipment Maintenance Management
AFMAN 23-110V1, PT1	Management of Suspect Counterfeit and Counterfeit Materials
ASME Y14.38	Abbreviations and Acronyms for Use on Drawings and Related Documents
DODI 5330.03_AFI 33-395	Document Automation and Production Service (DAPS)
SAE (Society of Automotive Engineers)	AS5553 Counterfeit Electronic Parts; Avoidance Detection, Mitigation and Disposition
IEEE-200	Electrical and Electronic Reference Designations
TO 00-5-1-WA-1	Air Force Technical Order System

TO 00-25-234

List of Related Publications - Continued

Number	Title
TO 00-25-195-WA-1	Source, Maintenance, and Recoverability Coding of Air Force Weapons, Systems, and Equipment
TO 00-25-234-WA-1	General Shop Practice Requirements for the Repair, Maintenance, and Test of Electrical Equipment
TO 00-25-251	Installation, Operation, Maintenance, Care and Handling Instructions, General Microwave Tubes, Magnetron Tubes, Electron Tubes
TO 00-25-259	Standard Maintenance Practices Miniature/Microminiature (2M) Electronic Assembly Repair Organizational/Intermediate/Depot Level
TO 00-35D-54	USAF Deficiency Reporting, Investigation and Resolution.<
TO 00-35D-54	USAF Deficiency Reporting, Investigation and Resolution.<
TO 1-1A-8	Engineering Manual Series Aircraft and Missile Repair Structural Hardware

List of Related Publications - Continued

Number	Title
TO 1-1A-14	Installation and Repair Practices Volume 1 Aircraft Electric and Electronic Wiring
TO 1-1A-15	General Maintenance Instructions For Support Equipment (SE)
TO 33-1-32	General Instructions for Input Power Wiring of Electrical/Electronic Support Equipment<
TO 33DA21-410-1	Operation and Maintenance Instructions With Illustrated Parts Breakdown Left-Hand and Right-Hand, BL157, Rib/Spar Holding Fixture Assemblies PN 16A11197-1 and PN 16A11198-1
TO 44H1-1-117	General Installation of Helicoil Inserts

5 RECORD OF APPLICABLE TIME COMPLIANCE TECHNICAL ORDERS (TCTOS).

List of Time Compliance Technical Orders

TCTO Number	TCTO Title	TCTO Date
None		

6 HCI HARDNESS CRITICAL ITEMS (HCI).



The HCI symbol (**HCI**) establishes special requirements limiting changes and substitutions and that the specific parts listed must be used to ensure hardness is not degraded.

posed substitutions of, HCIs must be approved by the acquiring activity.

If included, items with nuclear survivability requirements are marked with the HCI symbol (**HCI**). All changes to, or pro-

7  ELECTROSTATIC DISCHARGE SENSITIVE (ESDS) ITEMS.



All ESDS parts shall be handled in accordance with the ESDS device handling procedures in TO 00-25-234-WA-1.

If included, items containing ESDS parts are marked with the ESDS symbol (.

8 CHANGE RECOMMENDATIONS.

Recommendations proposing changes to this technical order shall be submitted on an AFTO Form 22 in accordance with TO 00-5-1-WA-1. Forward completed AFTO Form 22 to the Technical Order Management Agency (TOMA) at: robins.ce.afto22@robins.af.mil.

SAFETY SUMMARY

1 GENERAL SAFETY INSTRUCTIONS.

This manual describes physical and/or chemical processes which may cause injury or death to personnel, or damage to equipment, if not properly followed. This safety summary includes general safety precautions and instructions that must be understood and applied during operation and maintenance to ensure personnel safety and protection of equipment. Prior to performing any specific task, the WARNINGS, CAUTIONS, and NOTES included in that task shall be reviewed and understood.

2 WARNINGS, CAUTIONS, AND NOTES.

WARNINGS and CAUTIONS are used in this manual to highlight operating or maintenance procedures, practices, conditions, or statements which are considered essential to protection of personnel (WARNING) or equipment (CAUTION). WARNINGS and CAUTIONS immediately precede the step or procedure to which they apply. WARNINGS and CAUTIONS consist of four parts: heading (WARNING, CAUTION, or icon), a statement of the hazard, minimum precautions, and possible results if disregarded. NOTES are used in this manual to highlight operating or maintenance procedures, practices, conditions, or statements which are not essential to protection of personnel or equipment. NOTES may precede or follow the step or procedure, depending upon the information to be highlighted. The headings used and their definitions are as follows:

WARNING

Highlights an essential operating or maintenance procedure, practice, condition, statement, etc., which if not strictly observed, could result in injury to, or death of, personnel or long term health hazards.

CAUTION

Highlights an essential operating or maintenance procedure, practice, condition, statement, etc., which if not strictly observed, could result in damage to, or destruction of, equipment or loss of mission effectiveness.

NOTE

Highlights an essential operating or maintenance procedure, condition, or statement.

3 HAZARDOUS MATERIALS WARNINGS.

Hazardous Materials Warnings in this manual are provided through use of the Hazardous Symbols listed below. Consult the HAZARDOUS MATERIALS DESCRIPTION below or Material Safety Data Sheets (MSDS) (Occupational Safety and Health Administration on hazards, effects, and protective equipment requirements. If you do not have an MSDS for the material involved, contact your supervisor, or the base Safety or Bioenvironmental Engineering Offices.

3.1 Hazardous Materials Icons. Icons are used in this manual to identify dangers associated with hazardous materials. The icons used and their definitions are as follows.



The abstract symbol bug shows that a material may contain bacteria or viruses that present a danger to life or health.



The symbol of drops of liquid onto a hand shows that the material will cause burns or irritation of skin and tissue.



The rapidly expanding symbol shows that the material may explode if subjected to high temperatures, sources of ignition or high pressure.



The symbol of a person wearing goggles shows that the material will injure eyes.



The symbol of a flame shows that the material can ignite and burn.



The symbol of a skull and crossbones shows that the material is poisonous or a danger to life.



The symbol of three circular wedges shows that radioactive energy is emitted which can injure tissue and organs.

TO 00-25-234

3.2 Hazardous Materials Description. The following hazardous materials are used in this manual. Each icon represents certain hazards as described above. Beneath the icons is the hazardous material name and a reference number. Below the icons, material name, and reference number is a description of the hazardous material. Only the icons, material name, and reference number are used in the text of the manual. If a full description of the hazardous material is required while performing procedures in this manual, use the reference number to locate the appropriate description below.



THREAD COMPOUND, MIL-C-38736 1

Thread Compound, MIL-C-38736, is flammable and toxic to eyes, skin, and respiratory tract. Skin and eye protection required. Avoid repeated or prolonged exposure. Keep Thread Compound, MIL-C-38736, off skin, eyes, and clothes; do not breathe vapors. Keep away from open flames or other sources of ignition.



AMINE ACID HALOGENATED ORGANIC SOLVENT, MIL-S-4784 2

Amine Acid Halogenated Organic Solvent, MIL-S-4784, contains trace amounts of bacteria and is toxic to eyes, skin, and respiratory tracts. Respirator, skin and eye protection required. Keep Amine Acid Halogenated Organic Solvent, MIL-S-4784, off skin, eyes, and clothes; do not breathe vapors. Keep away from open flames or other sources of ignition.



ELECTRON TUBE, OA2 3

Electron Tube, OA2, contains radioactive material. Avoid repeated or prolonged exposure. TO 33DA21-410-1 lists pro-

TECTIVE equipment required and provides instructions for safe handling and disposal of radioactive tubes.

4 SAFETY PRECAUTIONS.

The following safety precautions shall be observed while performing procedures in this manual.

- Dangerous voltages are present at system connectors. Ensure power is OFF prior to connecting or disconnecting cables.
- Do not wear metal frame glasses, rings, watches, or other metal jewelry while working on electronic equipment.
- Some cleaning materials specified herein are flammable and/or toxic. Keep away from open flame or other ignition sources. Provide adequate ventilation and avoid skin/eye exposure.
- Cleaning with compressed air can create airborne particles that may enter eyes or penetrate skin. Pressure shall not exceed 30 psig. Wear goggles. Do not direct compressed air against skin.

WARNING

Isopropyl Alcohol is flammable and toxic to skin, eyes and respiratory tract. Skin and eye protection is required. Avoid repeated or prolonged contact. Use only in well ventilated areas. Do not use synthetic wiping cloths with flammable TT-I-735 isopropyl alcohol. Keep away from open flames or other sources of ignition.

5 USE OF LIQUID SOLDER FLUX, MIL-F-14256.

Liquid Solder Flux, MIL-F-14256, is commonly used throughout this manual. It is flammable and toxic to skin, eyes, and respiratory tract. Good general ventilation is normally adequate. Avoid skin and eye contact. Avoid all sources of ignition.

6 GIVE CLEANERS/CHEMICALS SPECIAL CARE.**NOTE**

Unused or waste chemical substances may be hazardous and must be disposed of in accordance with Federal, State and Local directives. Contact Base Environmental Personnel for specific disposal instructions.

Keep cleaners/chemicals in approved safety containers and in minimum quantities. Some cleaners/chemicals may have an adverse affect on skin, eyes, and respiratory tract. Observe manufacturer's warning labels and current safety directives. Use cleaners/chemicals only in authorized areas. Discard soiled cloths into safety cans. Consult the local Bioenvironmental Engineer and/or Material Safety Data Sheet (MSDS) for specific precautions, protective equipment, and ventilation requirements.

7 SOLDERING.

Avoid breathing fumes generated from soldering. Various metals have the potential to generate hazardous atmospheres. Good general ventilation is normally adequate. Eye protection is required. Before soldering, refer to TO 00-25-259 for procedures and consult the local Bioenvironmental Engineer for information on unfamiliar metals.

8 KEEP AWAY FROM LIVE CIRCUITS.

Operating personnel must think safety at all times. Do not replace components or make adjustments inside equipment

with the electrical supply turned on. Under certain conditions, danger may exist even when the power control is in the off position due to charges retained by capacitors. To avoid injuries, always remove power from, discharge, and ground circuit before touching it. Adhere to all lock out/tag out requirements.

9  ELECTROSTATIC DISCHARGE (ESD).

Certain circuit card assemblies and their components will be damaged by seemingly undetectable electrostatic discharge. Care must be exercised during handling/repair of these items. Use electrostatic discharge (ESD) precautionary procedures outlined in 00-25-234.

10 DO NOT SERVICE OR ADJUST ALONE.

Do not attempt internal service or adjustment of equipment unless another person capable of rendering aid and resuscitation is present.

11 USE CORRECT TECHNICAL DATA.

Do not attempt to repair or adjust and/or perform general maintenance on equipment without the correct technical data.

CHAPTER 1 INTRODUCTION

1.1 MATERIALS AND PARTS.

Materials and parts used in the repair of electronic equipment generally will be items covered by specification and itemized in Qualified Products Lists. These documents are subject to periodic amendments and revisions and their use shall supersede existing directives upon date of issue, unless otherwise directed. Materials and parts not so designated shall be of the best commercial quality, of the lightest weight, and suitable in all aspects for the intended application.

1.2 PARTS SUBSTITUTION.

To reduce the time that electronic equipment is out of service, equivalent parts can be substituted for unavailable parts. General criteria for equivalent parts is established in Chapter 4 of this document.

1.3 ECONOMICAL REPAIR.

To attain and maintain the most economical repair posture, unserviceable parts and assemblies, regardless of ERRC coding, for which parts availability can be determined from Il-

lustrated Parts Catalogs (-4 TOs/IPBs), Material Requirements (MRLs) or G-004A System (Maintenance Engineering Management System), shall be repaired when inspection reveals them to be in a repairable condition. Exception: Those parts/assemblies that are to be replaced as the result of modification. Replace unserviceable parts with serviceable parts when inspection reveals the unserviceable parts to be worn or damaged beyond a repairable condition. Parts worn or damaged beyond a repairable condition shall be condition condemned in accordance with AFMAN 23-110, pertaining Volume and Chapter.

1.4 RECOMMENDED TOOLS.

The tools (or their equivalents) listed in Table 1-1 are those recommended for general shop practices in the repair, maintenance, and test of electronic equipment. Tools are listed by functional area; tools required for a functional area are in addition to those elsewhere in the list.

Table 1-1. Recommended Tools

Item	NSN/Spec/Part Number
GENERAL REPAIR	
Brush acid	NSN 7920-00-223-8005
Chassis punch	NSL *
Crimping tool aluminum lug	MS25020
Crimping tool, power	NSL
Crimping tool, splice	AMP PN's 49430, 49556, 48431, 49557, 59062, 59118
	Burndy PN's MR8-1A, MR8-335
Crimping tool, terminal lug	MS25037
Eraser, typewriter	AA-132
Hot-air gun, electric	NSN 4940-00-314-9789
Installation tool, tie strap	PN GS-2B, Panduit Corp
Insulation stripper	NSN 5110-00-996-9389
Pin replacement tools (for MS24230 connectors)	PN 036052-0000, 036069-0000
Scriber, machinist	NSN 5120-00-224-9728
Soldering aids	NSN 3439-00-629-2697
Soldering center	NSN 4940-00-445-5965
Thermal shunts (heat sinks)	NSN 5999-00-076-1279
Twister, safety wire	NSN 5120-00-305-2306
Wire bending tool	NSN 5120-00-239-8252
	NSN 5120-00-188-3251
Wire wrapping tool	NSN 5120-00-808-6005

TO 00-25-234

Table 1-1. Recommended Tools - Continued

Item	NSN/Spec/Part Number
PRINTED CIRCUIT BOARD REPAIR	
Grounding kit	PN 4111, Biggom Enterprises, Inc.
Anvil, jeweler's	NSN 5120-00-618-4913
Arbor and band set	NSN 6520-00-500-9500
Blade kit:	
blade, surgical, no. 11	NSN 6515-00-043-1770
blade, surgical, no. 20	NSN 6515-00-044-1921
blade, surgical, no. 25	NSN 6515-00-299-8055
blade, surgical, no. 15	NSN 6515-01-009-5293
blade, surgical, no. 12	NSN 6515-01-009-5294
blade, surgical, no. 10	NSN 6515-01-009-5293
Brush, artist, small	NSN 8020-00-262-9098
Brush, artist, med	NSN 8020-00-224-8026
Brush, nylon	PN 375 HP, Gordon Brush Co.
Brush, stainless steel	PN 22SSA, Gordon Brush Co.
Burnisher, J, no. 27	NSN 6520-00-510-8150
Carver, dental, no. 1/2	NSN 6520-00-935-7171
Carver, dental, no. 3	NSN 6520-00-511-5450
Carver, dental, no. 5T	NSN 6520-00-935-7252
Carver, dental, no. 6T	NSN 6520-01-016-3690
Carver, dental, Roach	NSN 6520-00-511-5550
Chisel, Black, no. 48	NSN 6520-00-514-7050
Chisel, Black, no. 84	NSN 6520-00-536-4025 *NSL: Not stock listed.
Chisel, dental, Chandler, no. 1	NSN 6520-01-006-9343
Chisel, dental, Chandler, no. 4	NSN 6520-01-006-9344
Chisel, dental, Gardner, no. 5	NSN 6520-01-006-9345
Chisel, dental, no. 2	NSN 6520-01-047-3586
Chisel, dental, no. 41	NSN 6520-00-515-1050
Chisel, dental, no. 42	NSN 6520-00-515-1550
Chisel, 1/2 inch	NSN 5110-00-234-1927
Cooler, Component Pneumatic	Model #5810 (0ECV7)
Cutters, end, full flush	NSN 5110-P36-272
Cutters, diag, full flush	5110-P36-277
Cutters, diag, semi flush	5110-P36-275S
Cutters, diag, 6-inch	NSN 5110-00-239-8253
Cutters, offset, oblique, 20 degree	5110-P36-274
Cutters, wire	PN 42, AN-B-5316, Utica
Desoldering kit:	
tip, desoldering	NSN 3439-01-057-1002
tip, desoldering	NSN 3439-01-078-8351
tip, desoldering	NSN 3439-01-065-9650
tip, desoldering	NSN 3439-00-134-9201
tip, desoldering	NSN 3439-01-078-8351
Desoldering system	NSL
Drill, dental, with handpieces no. 77 and no. IMP-88D	NSL
Drill, twist, no. 44	NSN 5133-00-189-9289
Drill, twist, no. 51	NSN 5133-00-189-9296
Drill, twist, no. 52	NSN 5133-00-189-9297
Drill, twist, no. 55	NSN 5133-00-189-9300

Table 1-1. Recommended Tools - Continued

Item	NSN/Spec/Part Number
Drill, twist, no. 68	NSN 5133-00-266-9228
Drill, twist, no. 75	NSN 5133-00-266-9247
File, half round, 8 in.	NSN 5110-00-241-9147
File, needle, set of 12	NSN 5110-00-204-2685
Flashlight, penlight	Local purchase
Flux dispenser	NSL
Glass, magnifier with handle	NSN 6650-00-514-3531
Grinding kit:	
burr, cylinder, no. 57, HP	NSL
burr, cylinder, no. 59, HP	NSL
burr, cylinder, no. 556, HP	NSL
burr, cylinder, no. 556, RA	NSL
burr, cylinder, no. 558, HP	NSN 6520-01-003-2259
burr, cylinder, no. 558, RA	NSN 6520-01-003-2426
burr, cylinder, no. 560, HP	NSL
burr, cylinder, no. 560, RA	NSL
burr, cylinder, no. 1557, RA	NSL
burr, cylinder, no. 1557, HP	NSL
burr, cylinder, no. 1559, HP	NSL
burr, cylinder, no. 1559, RA	NSL
burr, dental trim, pear shaped	NSN 6520-01-027-0345
burr, dental trim, round	NSL
burr, end cutting, no. 901, RA	NSL
burr, end cutting, no. 957, RA	NSN 6520-00-000-0064
burr, end cutting, no. 957, HP	NSL
burr, end cutting, no. 958, RA	NSL
burr, in. cn, no. 33 1/2, HP	NSN 6520-01-003-3133
burr, in. cn, no. 35, HP	NSN 6520-00-721-6291
burr, in. cn, no. 35, RA	NSN 6520-01-003-2272
burr, in. cn, no. 37, HP	NSN 6520-00-721-6292
burr, in. cn, no. 37, RA	NSN 6520-01-003-5346
burr, in. cn, no. 39, RA	NSL
burr, pear shaped, no. 330, RA	NSL
burr, pear shaped, no. 332, RA	NSL
burr, round, no. 1/2, HP	NSN 6520-01-003-3132
burr, round, no. 1/2, RA	NSN 6520-01-049-0422
burr, round, no. 2, HP	NSN 6520-01-003-2269
burr, round, no. 2, RA	NSN 6520-01-003-2274
burr, round, no. 4, HP	NSN 6520-01-003-2270
burr, round, no. 4, RA	NSN 6520-01-003-2275
burr, round, no. 6, HP	NSN 6520-00-721-6296
burr, round, no. 6, RA	NSN 6520-01-003-7703
burr, round, no. 8, HP	NSN 6520-01-003-3131
burr, round, no. 8, RA	NSN 6520-01-003-2276
burrs, with case	PN 3200
mandrel, screw type, HP	NSN 6520-00-926-8846
mandrel, screw type, RA	NSN 6520-00-926-8845
mandrel, no. 303 1/2	NSN 6520-01-060-1667
Hammer, ball-peen, 4 oz	NSN 5120-00-061-8540

TO 00-25-234

Table 1-1. Recommended Tools - Continued

Item	NSN/Spec/Part Number
Handle, scalpel, no. 3	NSN 6515-00-344-7800
Handle, scalpel, no. 4	NSN 6515-00-344-7820
Handle, scalpel, no. 9	NSN 6515-00-344-7920
Holder, circuit card	NSL
Holder, device, electrical	NSN 5120-00-330-7602
Hypodermic needle	NSN 6516-00-754-2837
Hypodermic syringe, 2 cc	NSN 6516-00-889-3564
Knife/pin vise, with tools	NSN 5110-00-175-3629
Lead bender	NSN 5120P-176-BOU1
Machining unit, miniature	NSN 4940-00-495-4489
Magnifier, bench mount	NSN 6650-00-801-1681
Microscope illuminator	NSN 6650-00-578-6543
Microscope, stereo, zoom	NSN 6650-00-945-3098
Wrench set, socket	NSN 5120-00-089-3663
Soldering aid tool	NSN 3439-00-174-7846
Soldering aid tool	NSN 3439-00-174-7847
Pick, dental, straight	NSN 3439-PSH-1116
Pliers, common	NSN 5170-00-223-7396
Pliers, crimping	NSN 5120-00-446-8255
Pliers, long nose, 60 degrees, bent chain	NSN 5110-P36-267
Pliers, needle nose	NSN 5120-00-293-3481
Pliers, round nose	NSN 5120-00-239-8252
Pliers, smooth jaw, chain nose	NSN 5110-P36-263S
Pliers, smooth jaw, flat nose	NSN 5110-P36-261S
Pliers, smooth jaw, long nose	NSN 5110-P36-265
Pliers, smooth jaw, round nose	NSN 5110-P36-262S
Polishing kit:	
brush, soft, no. S11	NSL
brush, soft, no. S12	NSL
brush, soft, no. S13	NSL
brush, soft, no. S14	NSL
brush, stiff, no. A1	NSL
brush, stiff, no. A2	NSL
brush, stiff, no. A3	NSL
brush, stiff, no. B11	NSL
brush, stiff, no. B12	NSL
brush, stiff, no. B13	NSL
point, felt, no. 144	NSL
point, felt, no. 145	NSL
point, felt, no. 146	NSL
spindle set with discs	NSL
wheel, cotton, no. 86	NSL
wheel, felt, no. 160	NSL
wheel, rubber, no. 3271A	NSL
wheel, rubber, no. 3272A	NSL
wheel, rubber, no. 3273A	NSL
Pulse dot	CERCON Pulse Dot II
Punch, center	NSN 5120-00-293-3510
Rule, 6 in., 0.01 in. graduations	NSN 5120-00-204-1283

Table 1-1. Recommended Tools - Continued

Item	NSN/Spec/Part Number
Sandpaper, wet/dry	Any source
Sandpaper, disc	Any source
Sandpaper	Any source
Saw blade, no. 040	6520-LMAD-040
Saw blade, no. 060	6520-LMAD-060
Saw blade, no. 100	6520-LMAD-100
Saw blade, no. 190	6520-LMAD-190
Saw blade, no. 220	6520-LMAD-220
Seizer, soldering	NSN 5120-00-012-4016
Scissors, electric	NSN 5110-00-255-0420
Scissors, surgical, curved	NSN 6515-00-364-4600
Scissors, surgical, straight	NSN 6515-00-365-1200
Screwdriver set, jewelers	NSN 5120-00-288-8739
Screwdriver, flat	NSN 5120-00-278-1270
Screwdriver, 3 in., flat tip	NSN 5120-00-287-2504
Screwdriver, 3 in., flat tip, 3/16-in.	NSN 5120-00-236-2127
Screwdriver, 3 in., philips no. 1	NSN 5120-00-240-8716
Screwdriver, 3 in., philips no. 0	NSN 5120-00-060-2004
Slab, glass, mixing	NSN 6520-00-556-2000
Solder extractor tip, 0.018 in.	NSN 3439-01-057-1002
Solder extractor tip, 0.025 in.	NSN 3439-00-134-9201
Solder extractor tip, 0.036 in.	NSN 3439-01-065-9650
Solder extractor tip, 0.061 in.	NSN 3439-01-078-8351
Soldering aid, 90 degree	NSN 3439-00-174-7846
Soldering aid, curved	NSN 3439-00-174-7847
Soldering center, PRC-151	NSN 3439-01-109-8590
Soldering iron	NSN 3439-00-401-1373
Soldering kit:	
element, soldering iron, 27W	NSN 3439-00-337-6466
element, soldering iron, 33W	NSN 3439-00-317-2732
element, soldering iron, 45W	NSN 3439-00-827-3937
handle, soldering iron, 3-wire	NSN 3439P750
tip, soldering iron	NSN 3439-00-801-0952
tip, soldering iron	NSN 3439-00-801-0953
tip, soldering iron	NSN 3439-00-947-5389
tip, soldering iron	NSN 3439-01-063-4918
Spatula, no. 324	NSN 6520-00-556-8000
Insulation, thermal, strip	NSN 3455-00-149-8183
Caliper, lead binder	NSN 5210-00-050-5118
Tool set	NSN 5180-00-333-3266
Tweezers, anti-wick	NSN 3439-00-918-7918
Tweezers, curved, 4 1/2 in.	NSN 5120-00-288-9685
Tweezers, large, stainless steel	5120-PU-317
Tweezers, self locking	NSN 5120-00-293-0149
Tweezers, straight, 4 1/2 in.	NSN 5120-00-247-0868
Vise, bench	NSN 3460-00-221-1104
Vise, pin, 0.001 in. to 0.040 in.	NSN 5120-00-224-7271
Vise, pin, 0.025 in. to 0.062 in.	NSN 5120-00-243-1348
Vise, pin, 0.045 in. to 0.125 in.	NSN 5120-00-243-1349

TO 00-25-234

Table 1-1. Recommended Tools - Continued

Item	NSN/Spec/Part Number
Wrench set, allen (key)	NSN 5120-00-529-1475
Wrench set, open end	NSN 5120-00-962-7580
CONFORMAL COATING	
Applicator, cotton tip	NSN 6515-00-303-8250
Air gun, static sens	NSL
Brush, dental	5120P3159362019
Brush, soft bristle	6520-LMAD-S12
Brush, stiff bristle	6520-LMAD-OA2
Burr, dental	5120-P-315-2029
C-Clamp	NSN 5120-00-203-6439,
C-Clamp	NSN 5120-00-542-5929
Chisel, dental	NSN 6520-00-935-7178
Chisel, dental, no. 85	NSN 6520-00-536-4050
Chisel, dental, no. 86	NSN 6520-00-536-4125
Cleaning machine	NSL
Container, mixing, polyethylene	NSL
Disc, dental	5120P3159362029
Excavator, dental	NSN 6520-00-935-7184
Excavator, dental	NSN 6520-00-536-3450
Explorer, dental, no. 6	NSN 6520-00-528-0000
Explorer, dental, no. 17	NSN 6520-00-528-0005
Cartridge, Ion trap	NSN 4610-00-139-1494
Fume hood	NSN 6640-01-010-8497
Gloves, rubber	NSN 8415-00-266-8677
Gloves, surgical, antistatic	NSN 6515-00-782-6473
Goggles, safety	
Handle, dental	NSN 6520-00-890-1778
Illuminator, microscope	NSN 6650-00-578-6543
Knife, X-acto	NSN 5110-00-596-8098
Microscope, zoom	NSN 6650-00-539-7298
Tester, ionic contam spudger	NSN 6630-01-104-2901
Orange (wood) stick	NSN 5120-00-293-3112
Oven, forced air	
Paint gun, feather	NSN 4940-00-396-1663
Polisher, dental	5120L31431592029
Scale	NSN 6670-00-238-9765
Scaler, dental, Jaquett, no. 1	NSL
Scaler, dental, point, no. 6	NSN 6520-00-890-1783
Soldering iron tip, no. 2	NSN 6520-00-890-1779
Soldering iron tip, no. 3	NSL
Soldering iron tip, no. 4	NSL
Spray booth	NSN 4940-01-076-7925
Test tube 10 mm x 75 mm	PN KIMAX 45042, Kimble Glass Co.
Tongue depressor	NSN 6515-00-324-5500
Ultraviolet light	NSN 6635-00-611-5617
Vacuum chamber	NSL
Vibrator	PN AT-6M-0120528

CHAPTER 2

WORKMANSHIP

2.1 GENERAL.

Repaired and refinished equipment, (including parts and accessories), shall equal or exceed reliability and operating standards set forth in the applicable equipment handbook, technical order or operational standard. Particular attention shall be paid to good workmanship practices such as proper use of tools and maintenance of clean, well organized work areas. This chapter provides general criteria for: fabrication of nonelectronic parts; wiring; thermal and mechanical bonding; marking; handling, and storage.

2.2 WIRING.

All wiring shall meet the following electrical and mechanical standards: connections shall be completely soldered or crimped to provide minimum electrical resistance. Insulation shall be free of frayed areas, cracks, cuts, abrasions or evidence of overheating. Wire shall be of sufficient length to prevent stress to connections, terminals, or the wire itself. When practical, wires shall be bound into cables and routed to preclude damaging bends and contact with heated, abrasive, or sharp objects. Chapter 4 provides detailed insulation repair, cable lacing, and splicing procedures.

2.3 THERMAL BONDING.

Thermal bonding is the joining of metal by welding, brazing, soldering, or thermal compression. Mechanical and structural damage requiring welding or brazing shall be routed to the appropriate repair facility. Detailed soldering procedures and equipment and material descriptions are contained in TO 00-25-259.

2.4 MECHANICAL BONDING.

The various pins, rivets, and threaded fastener used in mechanical bonding shall be inserted and tightened with enough force to rigidly join parts, but not so much force as would damage parts. Where equipment handbooks or technical orders provide torque measurements for specific threaded fasteners, a torque wrench shall be used. Insertion procedures, applications, and criteria for pins, rivets, and threaded fasteners are given in Chapter 4.

2.5 INSULATING.

Exposed electrical connections and terminals shall have 0.05-inch minimum clearance from mounting hardware, other electrical connections, and equipment casings and coverings. Electrical connections and terminals shall be insulated when, during normal equipment usage, an equipment casing or cover can be shifted or dented so as to contact the exposed connection or terminal.

2.6 REPAIR AND REFINISHING.

Minor dents or bends in equipment casings and covers will be repaired using a backup tool and a hammer. Damage to structural members or to items requiring molds or forms for repair shall be repaired at the appropriate maintenance facility. Repaired areas shall be cleaned, treated, and refinished in accordance with the directions for the specific equipment. When specific directives for cleaning and refinishing are not available, the repaired area shall be cleaned, treated, and refinished in accordance with procedures contained in Chapter 4.

2.7 MARKING.

Designations used for marking equipment and parts shall conform to IEEE-200. Marking inks formulated from alkyd or alkyd-nitrocellulose resins must be covered with transparent fungus-resistant coating conforming to either specification MIL-V-173 or TT-V-109. Characters shall be Gothic capital letters and Arabic numerals. Characters shall be clean and clearly legible. Marking procedures and criteria are contained in Chapter 4.

2.8 CLEANING.

During periodic maintenance and prior to repair, equipment shall be cleaned in accordance with procedures in specific equipment directives. When specific directives are not available equipment shall be cleaned in accordance with procedures contained in Chapter 4. Applicable procedure shall be determined by consideration of the equipment and the nature

TO 00-25-234

and amount of contamination present. For cleaning ESD items, refer to Chapter 7 of this TO.

NOTE

Consumable materials listed in this TO are not expected to be all inclusive. The systems specific TO should be the primary reference for repair and maintenance. Individual substitute materials or processes must be qualified on a case-by-case basis to ensure material compatibility and system performance. Substitute materials shall not present adverse effects to human health or the environment.

2.9 HANDLING AND STORAGE.

To prevent damage to electronic equipment during handling and storage, electronic assemblies shall be placed in individual containers or in a common container with a suitable barrier material between them. During temporary storage or interim handling within a single facility, sufficient packing material shall be included to prevent shifting of electronic assemblies within the container. Type of container and degree of packing shall be determined by consideration of assembly cost, weight, fragility, and type of transportation between areas.

2.9.1 Protective Measures for Electrical Connectors.

Never apply pressure sensitive tape directly to connectors.

All equipment that is electrostatic discharge (ESD) sensitive requires the use of ESD caps. All unmated connectors (including waveguide connections) that are exposed to physical or environmental damage, or are in an area where such damage could occur shall be covered with a protective cap. Caps shall be moisture proof and vapor proof if available. Before installing internal-style caps in connectors with RFI gasket, verify the cap will not contact the RFI gasket. If necessary, install the dust cap over the collar to prevent damage to the RFI gasket. Protective caps specified by Military Specifications or Military Standards and designed for mating with specific connectors shall be used. Where such protective caps are not available, disposable plastic or metallic caps designed for the purpose shall be used.

NOTE

Intermediate field shops and Depot facilities are exempt from using protective covers on equipment utilized in the shop environment as physical or environmental damage is not likely to occur in these areas. This does not apply to ESD devices per Paragraph 7.4.1.3.

2.9.2 Preparation for Shipment and Storage. For shipment to another facility or long term storage, electronic assemblies will be packaged as shown in Figure 2-1, Figure 2-2, and Figure 2-3. Figure 2-1 illustrates protective packaging for bolt-down, chassis-type electronic assemblies; Figure 2-2 illustrates protective packaging for plug-in, circuit board-type electronic assemblies; and Figure 2-3 illustrates protective packaging for plug-in type electronic assemblies. Regardless of the electronic assembly design, all pins, shafts, dials, and protruding parts must be adequately fitted with packing spacers and the complete assembly properly wrapped with plastic or placed in a plastic ziplock bag, then wrapped with a protective cellulose, form, or similar material. Assemblies that contain electrostatic discharge sensitive (ESDS) parts must be wrapped in static protective materials. (Chapter 7).



Do not use these desiccant crystals when packaging defective electronic assemblies. Since the assembly must be packaged tightly, crystals in bag form cannot be used; the use of loose crystals may cause unnecessary damage resulting in a cleaning problem.

- a. Desiccant crystals are normally packaged with assembled equipment crated for shipment or storage. These crystals are retained in a bag and placed within the crated or packaged equipment in such a manner that they will not come loose in the equipment.

WARNING

P-D-680, Type III, Cleaning Solvent is toxic to skin, eyes, and respiratory tract. Skin and eye protection required. Avoid repeated or prolonged contact. Good general ventilation normally adequate. Do not use on electrical parts and rubber jacketed cords and cables.

- b. If an electronic assembly should become exposed to loose desiccant crystals, clean the assembly immediately. Do not turn moving parts any more than absolutely necessary until all of the crystal particles have been blown or brushed away. In testing the moving parts for cleanliness, turn them very slowly and gently. Do not force the parts, if gritty. Work out the crystal particles with a brush or dry, filtered compressed air. Wash the electronic assembly, in an approved solvent (P-D-680, Type III, Cleaning Solvents or equivalent), rinse with isopropyl alcohol to remove residue, brush and blow dry, then check and test the assembly (as instructed in the equipment manual) before using it in the equipment. If the equipment functions improperly,

check the assembly for the presence of crystal particles and defective parts. Before replacing the assembly, repeat the cleaning procedure.

2.9.3 Handling. Much unnecessary damage has occurred to electronic assemblies because of rough handling. Particular care must be given to the method of removing or inserting an assembly into the equipment. If it is a plug-in, board-type assembly, be sure the guide pins are properly aligned before pressing the assembly in place. If the board should tilt while being inserted, do not continue to press into position; straighten it, then apply even pressure to avoid tilting. Forcing any tilted or cocked electronic assembly into position may result in bent or broken pins.



- Electronic assemblies containing solid-state devices are susceptible to damage from static electrical discharges. Chapter 7 provides information on electrostatic discharge control.
 - To prevent damage to electronic circuitry ensure all keying devices (or guides that functions as keys) are present and aligned prior to making connection with mating receptacle.
- a. Because of the miniaturization of parts for electronic assembly construction, the leads, connectors, and pins

have been stiffened to make them more rugged. As a result, such parts are brittle and will break easily if bent too often or pulled on too hard. When handling an assembly that has been removed from its chassis, be careful not to press against the leads and pins. If a lead or pin is accidentally bent, do not try to straighten it unless absolutely necessary.

- b. When repairing an electronic assembly, be careful that the tool employed does not inadvertently press against leads, pins, or other parts that are easily bent. Such pressure can destroy a good part and cause needless repair.
- c. When removing an assembly, be sure to pull it straight out from the equipment. Do not cock, twist, pry, or carelessly jerk an electronic assembly to remove it from the mounting or connector.

TO 00-25-234

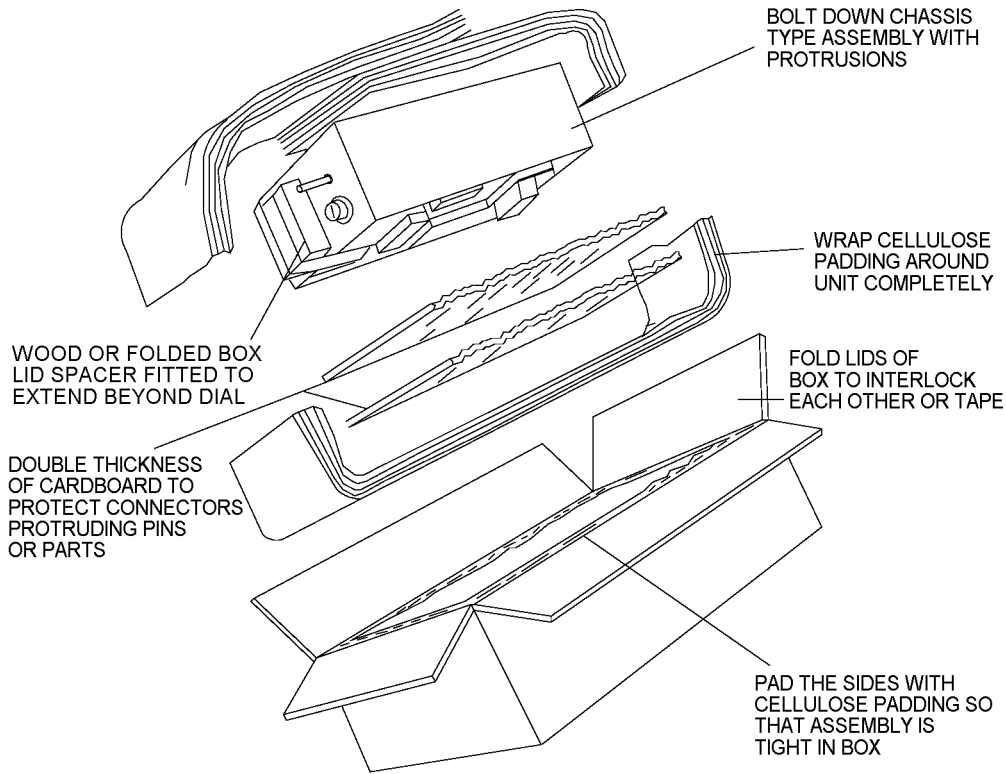

Figure 2-1. Chassis-Type Electronic Assembly, Protective Packaging

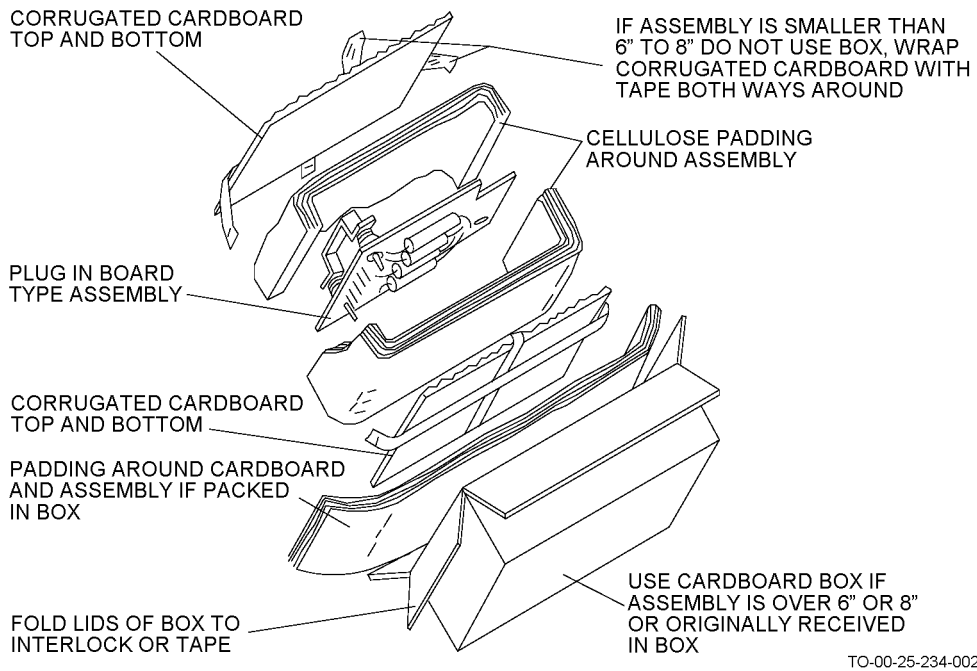
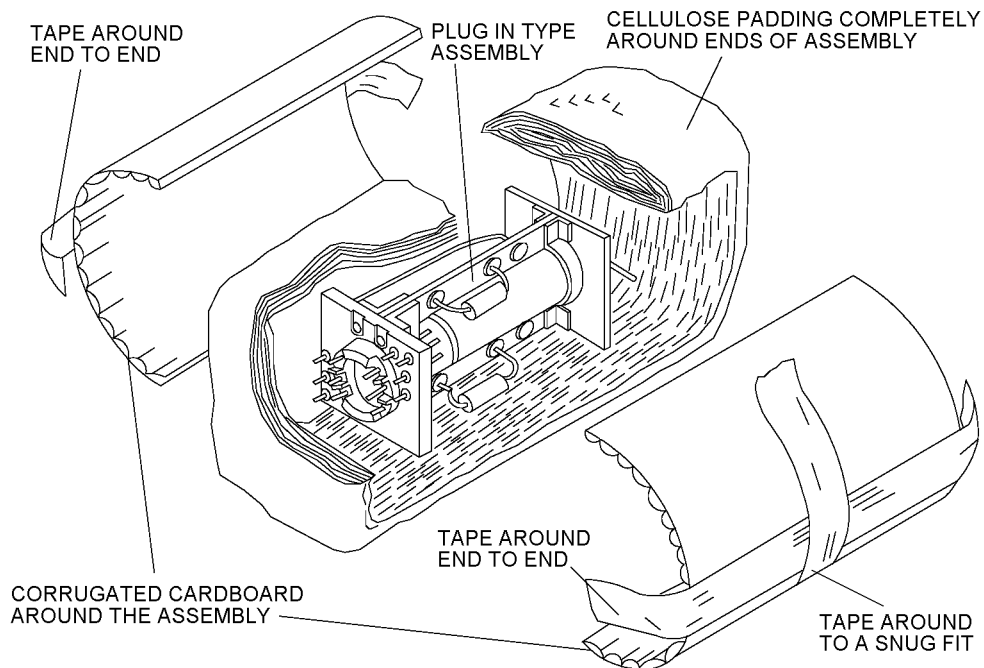

Figure 2-2. Circuit Board-Type Electronic Assembly, Protective Packaging



TO-00-25-234-003

Figure 2-3. Plug-In Type Electronic Assembly, Protective Packaging

2.10 INSPECTION.

All electronic equipment shall be visually inspected prior to testing, and following any repair action. The intent of this inspection is to detect obvious defects that might otherwise go unnoticed, and to make sure additional damage has not been introduced during a repair action. The inspection further looks for defects that might cause additional damage to equipment should power be applied. The visual inspection consists of but is not limited to checking for:

- a. No excessive overheating of electronic components.
- b. No loose or missing mechanical hardware.
- c. Proper mechanical operation of controls.
- d. No frayed, burnt, pinched, or broken wires.

- e. Chassis mounted components and printed circuit cards securely mounted.
- f. Mechanical, crimped, and soldered electrical connections secure and serviceable.
- g. No missing, damaged, recessed, or bent connector contacts and insulation around contacts serviceable.
- h. Mechanical integrity of case intact.

NOTE

Refer to applicable paragraphs within this technical order for additional inspection criteria/repair procedures for specific equipment discrepancies.

CHAPTER 3

SOLDERING

3.1 GENERAL.

Soldered connections are used in electronic equipment to form a continuous and permanent metallic connection having a constant electrical value. The importance of establishing and maintaining a high standard of workmanship for soldering operations cannot be overemphasized. The chapters of this TO that describes the processes used in soldering electronic equipment wiring, printed circuit boards, and microcircuits have been removed from this TO and personnel

shall refer to TO 00-25-259, Standard Maintenance Practices Miniature/Microminiature Electronic Assembly Repair, for soldering instructions. TO 00-25-259 contains the appropriate safety precautions and information on soldering procedures and techniques necessary to assure a satisfactory soldered joint. When other technical documents refer personnel to this TO for soldering operations, TO 00-25-259 maintains precedence and personnel shall refer to TO 00-25-259 for proper soldering processes and procedures.

CHAPTER 4

GENERAL REPAIR

4.1 GENERAL.

This chapter gives general testing criteria and includes tools, materials, and fabrication techniques for minor mechanical parts and chassis. The chapter also includes a general troubleshooting procedure, criteria for repair or replacement of parts, and safety precautions to be taken during repair of electronic equipment.

- a. Table 1-1 lists the tools and equipment called out in this chapter; Table 4-1 lists the materials recommended.
- b. Other than tools and materials, the following are referenced in this chapter:

TO 1-1A-14, Aircraft Electric and Electronic Wiring.

TO 1-1A-15, General Maintenance Instructions for Supp. Equipment (SE).

TO 33-1-32, Inspection of NSN Equipment and Replacement of 2-Wire Power Cords and Receptacles.

TO 44H1-1-117, General Installation of Helicoil Inserts.

IEEE-200 Electrical and Electronic Reference Designations.

TO 1-1-689-3, Cleaning and Corrosion Control of Avionics and Electronics.

4.2 SAFETY.

Use care in performing all operations outlined in this chapter. Observe the safety precautions contained in the following paragraphs.

4.2.1 Work Area. Provide a safe work area in the following manner:

- a. Maintain sufficient illumination.
- b. Maintain sufficient ventilation.

- c. Maintain adequate fire-fighting devices at conspicuous accessible locations.
- d. Maintain first aid equipment at a conspicuous location.
- e. Keep unused tools and materials in designated locations.
- f. Clean area as required and temporarily store rubbish in fire-resistant containers.

4.2.2 Rotating Machinery. Machinery operation shall be as follows:

- a. Allow authorized personnel only to operate machines.
- b. Do not wear loose clothing while operating machinery.
- c. Do not allow items to hang or protrude from clothing while operating machinery.
- d. Protect eyes with safety goggles.

4.2.3 Chemicals. Handle chemicals in the following manner:

- a. Protect eyes with safety goggles.
- b. Avoid skin contact with chemicals.
- c. Prevent prolonged skin contact with chemicals.
- d. Wash skin contacting chemicals.
- e. Wash hands immediately after using chemicals.
- f. Ensure adequate ventilation to eliminate hazardous vapor or dust concentrations.
- g. Do not inhale vapor or dust from chemical solutions.

TO 00-25-234

h. Provide air respirators in areas where acids, alkalis, cyanides, fluorides, chromates or organic solvents are used.

WARNING

Sulfuric acid is toxic and corrosive. Avoid all contact. Full face shield, rubber gloves, and apron required while mixing. Add acid to water slowly; stir while mixing. Never add water to acid. Use only with adequate ventilation.

i. To prepare an acid solution, slowly add acid to water while stirring solution.

WARNING

Do not allow cyanide materials to come in contact with any acid. Mixing cyanide with any acid forms hydrogen cyanide, a deadly gas.

j. Use extreme caution when using oxidizing agents in the presence of acetic acid.

k. To prepare an alkaline solution, add alkali to water slowly in small amounts, and stir solution until alkali is completely dissolved before adding more alkali.

l. Utilize face masks when handling chromate materials to prevent inhalation of toxic chromate vapors.

m. Most organic solvents are flammable. Do not use near open flame or spark. Some chlorinated hydrocarbons form phosgene or other toxic chlorides when exposed to flame or excess heat.

Table 4-1. Recommended Materials

Item	NSN/Part Number/Spec
Acetone	O-A-51
Adhesive, epoxy resin	MMM-A-134, Type I
Aliphatic naphtha	TT-N-95
Aluminum sheet, 0.010 to 0.020 in. thick	QQ-A-250/11, 6061-T6
Black Pigment	GV 1747
Brass polish	NSN 7930-00-056-7874
Brushes Acid Swabbing	NSN 7920-00-514-2417
Cleaner, aerosol	
Compound, Dow Corning No. 4	NSN 6850-00-177-5094
Compound, environmental sealing	MIL-S-38228, Type I or equivalent
Compound, isolating	MIL-S-8660 (GE)
Compound sealing	MIL-S-8516 (Presstite No. 106.5 EC-1120, or equivalent)
Detergent	NSN 6850-01-184-7453
RTV 3140 Insulating Compound	MIL-A-46146, NSN 5970-00-110-8234
Graphic Lamcord	MICA Insulator
Grease, Silicone	
Grease, Silicone INS	G-300, 9150-00-753-4588
Isopropyl alcohol	TT-I-735, Grade A, Technical
Lacing cord, ribbon:	MIL-T-713
No. 4	
No. 6	
No. 9	
No. 12	
Litmus paper, blue	NSN 6640-00-290-0146

Table 4-1. Recommended Materials - Continued

Item	NSN/Part Number/Spec
Conductive	PN 72-00016, Technical Wire Products 9150-01-332-463 Cranford, NJ
Plastic polish	NSN 7930-00-634-5340
Sodium bicarbonate	AA-374
Solvent, Hydrofluoroether (HFE)	A-A-59150A
Solvent, Stoddard	MIL-PRF-680B
Spray, Dow Corning No. 4X	NSN 9150-00-823-7860
Terminal lugs	MIL-T-7928, MS25036
Wire, steel, 0.020 in.	MS20995
Wire steel, corrosion resistant	WW-W-423
Wire, steel, soft zinc coated	AN-N-22
Wire, steel, zinc coated	QQ-W-461, Type 2, annealed grade

NOTE

Use Environmental Protection Agency (EPA) non-ozone depletion chemicals/solvents or local processes approved for Air Force manufacture/repair of avionics equipment.

- n. Store flammable liquids in quantities exceeding eight ounces in stainless steel, or equivalent, cans with flash-back arresters.
- o. Strong oxidizing agents such as chlorates, perchlorates, or peroxides shall be stored separately from flammable materials and from mineral acids.
- p. Separate acids and alkalies in storage.

4.2.4 **Electronics.** Safety precautions prescribed in AFI 91-203, Chapter 30 shall be followed when maintaining Communications- Electronics (C-E) systems. Safety precautions prescribed in AFI 91-203, Chapter 34 shall be followed when maintenance is performed on Precision Measurement Equipment Laboratory (PMEL) units.

4.2.5 **Power Extension Cables.** All extension power cables and detachable power cables used with electronic equipment shall be checked as required by TO 33-1-32.

4.3 **EQUIPMENT CASES AND PANELS.**

WARNING

Epoxy resins and sealants are flammable and toxic to eyes, skin, and respiratory tract. Skin/eye protection required. Avoid all skin contact. Good general ventilation is normally adequate. Keep away from open flame or other sources of ignition.

Equipment cases and panels may be repaired as follows:

4.3.1 **Dents and Chips.** Dents and chips in all electronic cases and instrument panels and holes and cracks in unpressurized electronic cases and instrument panels only may be repaired with MIL-S-38228, Type I, Environmental Sealing Compound. Procedures for metal surface preparation, application, and curing provided by the vendor with this material shall be followed. After curing, this sealant may be sanded to conform to the original surface and overcoated with the applicable finish system to match the surrounding area.

4.3.2 **Cracks and Holes.** Cracks and holes in pressurized electronic cases and instrument panels may be repaired as follows:

- a. Smooth out jagged edges of holes and/or cracks such that they are relatively flush with original surface.
- b. Cut out a metal patch such that it will overlap the edges of the crack or hole by a minimum of 1/2 inch on all sides. Use sheet aluminum, 6061-T6, QQ-A-250/11, 0.010 to 0.020 inch thick.
- c. Apply the metal patch over hole or crack on the interior of the unit using MMM-A-134, Type I, Epoxy Resin Adhesive. Procedures for metal preparation, application, and curing provided by the vendor with this material shall be followed. Some slight pressure on the face of the patch may be required to hold it in place while the adhesive is curing.
- d. Fill any irregularity remaining on the exterior of the unit using MIL-S-38228, Type I, sealant or equivalent.

4.3.3 **Connectors.** AN and MS connectors will be inspected and/or rejected for the following conditions.

- a. Missing, damaged, recessed, or bent pins.

TO 00-25-234

- b. Cracks extending between pins or pin sockets of sufficient depth to expose the metal contact.

4.4 EQUIPMENT PERFORMANCE.

Repaired equipment shall meet electronic and mechanical performance requirements set out in equipment handbooks, standards or other applicable official directives. When performance requirements are not contained in Air Force publications, commercial standards are acceptable provided approval is contained in applicable official directives or prior approval is obtained from the activity having management responsibility for the equipment involved. If neither Air Force nor commercial performance requirements are available, request this data from the AFMC activity responsible for maintenance engineering management of the equipment involved (reference D086 or DO43A).

4.4.1 Deviations. Deviations from performance requirements shall not be permitted without written authorization from the Air Force activity having prime responsibility for the specific equipment.

4.4.1.1 Performance Test Conditions. Equipment must meet minimum requirements under simulated service conditions as directed by technical orders, engineering standards, and/or other applicable official publications. Unless otherwise specified, conduct tests under the following conditions:

Temperature	+104 °F (+40 °C) to +68 °F (+20 °C)
Altitude	Normal ground
Vibration	None
Humidity	Room ambient up to 90 percent relative humidity

4.4.1.2 Vibration and Shock Testing. Perform vibration and shock testing of electronic equipments at depot maintenance activities only when such tests are directly required to satisfy conditions of serviceability as prescribed by specific technical orders or other applicable official directives.

4.4.2 Vibration Testing. Vibration test procedures, unless outlined in specific directives, are as follows:

- a. Vibrate unit under test at a frequency varying between 10 and 55 cycles per second and at an amplitude of 0.06 inch total excursion. Vary frequency uniformly from 10 to 55 cycles per second and return to 10 cycles per second in approximately one minute.
- b. Vibrate unit under test vertically for the period necessary to conduct test.

- c. The unit under test shall meet minimum performance requirements during and subsequent to each test.

4.4.3 Shock Testing. Perform shock tests, when required by governing directives, in accordance with procedures contained in official directives for the individual equipment.

4.5 MECHANICAL FABRICATION.

Maintenance and repair of electronic equipment often requires fabrication of minor mechanical parts, braces, and even the construction of test chassis and jigs. Although the electronic technician is primarily concerned with the repair of electronic circuits, some knowledge of mechanical fasteners, cabling, insulation, cleaning procedures, and marking and identification is necessary. Paragraph 4.5.1 through Paragraph 4.5.7 contain a general description of chassis construction, mechanical fasteners, wiring, cable binding, types of electrical connections, insulating materials, cleaning procedures, corrosion prevention, pressurization, and marking and identification.

4.5.1 Chassis Construction. Test chassis or modification assemblies are generally constructed of aluminum or light sheet metal. Due to the large variety of specialized tools available, and with techniques limited only by the operators' ingenuity, only a general procedure for chassis construction utilizing readily available tools is presented.

- a. Make a pattern to scale on thin paper-stock, showing the layout of all parts, holes to be drilled and punched and aprons to be formed.
- b. Select sheet metal of sufficient gauge to make a sturdy chassis of the overall dimensions required by the pattern.
- c. Using a scribe (Figure 4-1) transfer chassis pattern to the sheet metal.

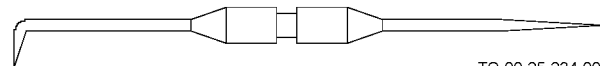

TO-00-25-234-004

Figure 4-1. Typical Scribe

- d. Cut sheet metal with tin snips and form the aprons and apron lips.
- e. If required, fasten the apron lips together with rivets or by soldering.

- f. Punch or cut mounting holes with appropriate chassis punches or chisel. Figure 4-2 illustrates a typical circular chassis punch.

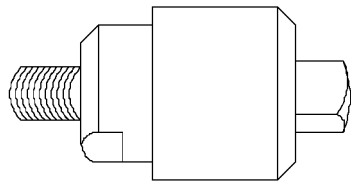

TO-00-25-234-005

Figure 4-2. Typical Chassis Punch

- g. Drill holes having a diameter of 1/4-inch, or less, with a hand drill. Larger diameter holes shall be made using a hand reamer or a circular chassis punch.

4.5.2 **Pins.** Electronic equipment uses three major classes of fits for pins; snug fit (class 4), such as used for dowel and taper pins; tight fit (class 6), such as used for drive pins and spring pins; and loose fit (class 1), such as used for clevis pins.

4.5.2.1 **Snug Fit.** Dowel pins are manufactured to precise dimensions with chamfered or crowned ends facilitating insertion into receiving holes. Holes for dowel pins require precision preparation such as reaming or grinding. Holes are chamfered as required. Figure 4-3 illustrates the application of a dowel pin in a blind hole. Insert pin in line with the holes to prevent binding. Drive pin into the holes with a soft metal faced mallet or press in with an arbor type press. Taper pins are also manufactured to precise dimensions and require a close tolerance hole drilled to nominal size. Figure 4-4 illustrates applications of taper pins. When staked for security, the taper pin length will equal approximately the diameter of the material receiving the taper pin. If unstaked, the taper pin length will equal the diameter of the material receiving the taper pin plus 0.06 inch.

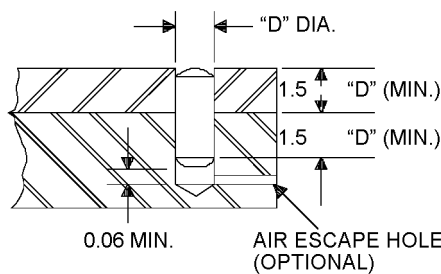

TO-00-25-234-006

Figure 4-3. Application of Dowel Pin

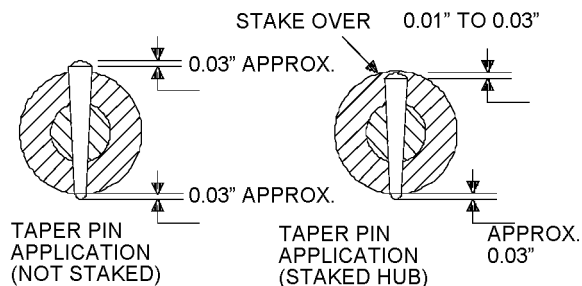

TO-00-25-234-007

Figure 4-4. Application of Tapered Pins

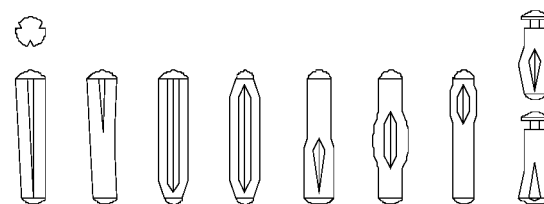

TYPES OF DRIVE PINS

SPRING PINS

TO-00-25-234-008

Figure 4-5. Typical Drive Pins and Spring Pins

4.5.2.2 **Tight Fit.** Drive pins and spring pins (Figure 4-5) require drilled holes having a diameter slightly less than the diameter of the pin. Drive pins are manufactured with equally spaced compression grooves around the pin shank. Driving the pin into a hole causes the grooves to compress, developing a pressure against the walls of the hole and holding the drive pin in place. Used drive pins shall be discarded. Spring pins are also compressed when driven into a hole and attempted expansion provides pressure against the walls of the hole, thereby, holding the spring pin in place. Undamaged spring pins may be reused as required.

4.5.2.3 **Loose Fit.** Loose fit pins, such as a clevis pin (Figure 4-6), are headed at one end and held in place by a retainer such as a cotter pin at the other end. The cotter pin must wrap around the clevis pin shank and must not protrude to catch on clothing or cause personal injury.

TO 00-25-234

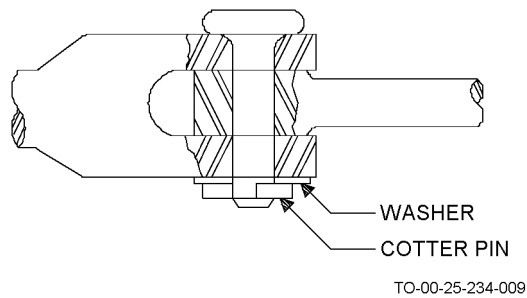

Figure 4-6. Clevis Pin

4.5.3 **Rivets.** Flush and raised-head type rivets are generally used in electronic equipment for fastening braces and mounting parts. Rivets shall be set using hand operated rivet squeezers, when permitted by equipment design and application and physical location of rivet. Flushhead type rivets require counter-sunk or skin-dimpled holes (Figure 4-7) to receive the tapered rivet head. Skin-dimpling is the non-subtractive formation of an indentation around the edge of a hole. Sub-dimpling is the formation of a similar indentation on an inner sheet of metal which receives the skin-dimpling on the outer sheet.

- a. The following general precautions shall be observed during rivet setting operations:
 - (1) Shock sensitive components shall be removed from equipment or protected during rivet setting operation.
 - (2) Rivet setting tools shall not strike or mark parts being joined.
 - (3) When rivet accessibility or specific official directive prevent the use of a rivet squeezer, a bucking bar of sufficient mass to assure complete setting and expansion of the rivet shall be used.
 - (4) For raised-head rivets the bucking bar shall have a recess (Figure 4-8) of appropriate size and shape to accommodate the manufactured head of the rivet and transfer the compressive forces to the rivet shank.
 - (5) Ensure that bucking bar does not rock or bounce during rivet setting operation.
- b. Unless otherwise specified by design or official directive, both flush and raised-head type rivets and connections shall conform to the following criteria:

- (1) There shall be no movement between riveted parts.

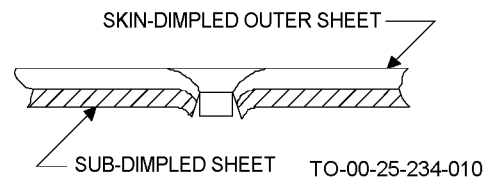
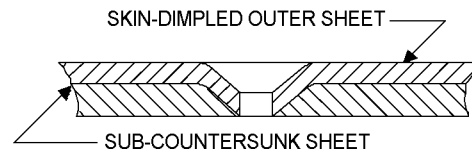
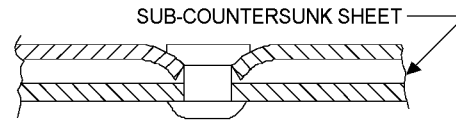
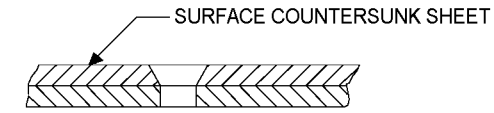
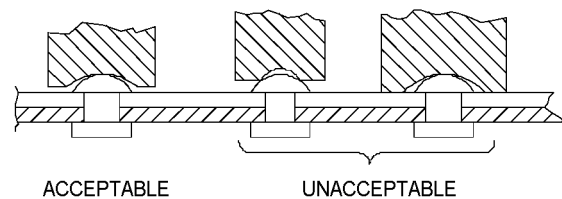

Figure 4-7. Countersunk and Skin-Dimpled Rivet Holes



TO-00-25-234-011

Figure 4-8. Bucking Bar Recess

- (2) Diameter of upset (flattened end of rivet) shall be approximately 1 1/2 times the diameter of rivet shank.

- (3) Gap (Figure 4-9) between tapered side of flush-head rivet and countersunk or dimple shall be a maximum of 0.002 inch around circumference of rivet head.
- (4) A gap of up to 0.022 inch is permissible, providing it extends for less than 1/3 of the rivet head circumference.
- (5) Gaps under the manufactured head of raised-head rivets shall be a maximum of 0.004 inch and will extend for less than 1/3 of the rivet head circumference.

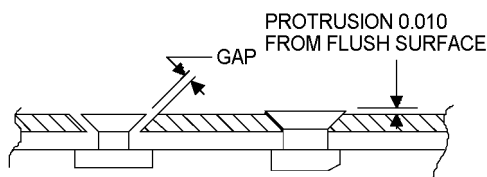

FLUSH RIVET
WITH GAP
UNDER HEAD

TO-00-25-234-012

Figure 4-9. Rivet Head Criteria

- (6) Rivets shall be reworked when ten percent, or more, of a ground approach the maximum limits established in c, d, and e.
- (7) Flush-head rivets shall not protrude more than 0.01 inch above the flush surface.

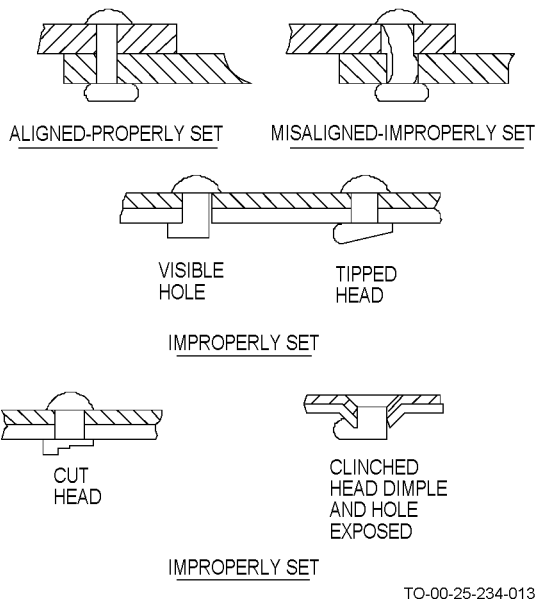
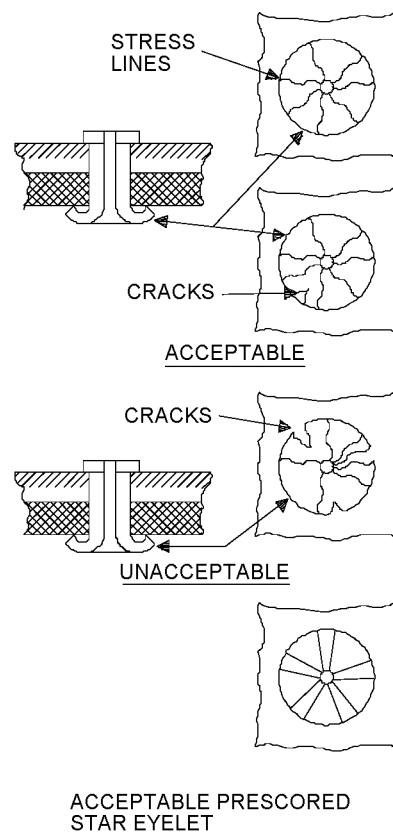

Figure 4-10. Properly and Improperly Set Rivets

- c. Figure 4-10 illustrates properly and improperly set rivets. Improperly set rivets shall be rejected.

4.5.4 Eyelets. Tubular rivets and eyelets shall be installed with the manufactured head against the softer of the two materials being joined. The upset end of the eyelet shall form a smooth curl, with the shank swelled against the side of the hole sufficiently to prevent rotation of eyelet under finger pressure. Figure 4-11 illustrates acceptable and unacceptable eyelets. One staking crack is acceptable providing the crack does not enter the shank. Stress lines are acceptable providing the metal is not split.

4.5.5 Studs. Studs (Figure 4-12) are generally cylindrical. The stud end is shaped according to stud application, such as grooved for a retaining ring or split for a terminal connection. The shank end of a stud is smaller in diameter than the stud end and may be either solid (like a rivet) or tubular (like an eyelet). The criteria and provisions for setting rivets shall apply to solid shank ends; those for eyelets shall apply to tubular shank ends.



TO-00-25-234-014

Figure 4-11. Acceptable and Unacceptable Eyelets

4.5.6 Retaining Rings. A retaining ring (Figure 4-13) holds a part on a stud or shaft, or retains a part within a housing device. Typical types of retaining rings, such as snap rings, spiral rings, and Truarc rings, are installed in the following manner:

TO 00-25-234

- Remove all burrs and sharp edges on the shaft or stud receiving the retaining ring.
- Press snap rings into the receiving groove of the shaft or stud by hand.
- Expand a spiral ring by hand, place it onto the shaft or stud, and release when positioned in the groove.
- Expand, or compress, as required, a Truarc ring with special pliers that fit into slots or holes in the ring, and install ring onto, or onto the receiving stud or housing.

4.5.7 Threaded Fasteners. Threaded fasteners used in electronic equipment shall be of sufficient size and strength to accomplish the holding, fastening, or other intended purpose. Threads, preferably of the coarse thread series, shall conform with provisions of Specification MIL-S-7742. Threaded fasteners shall conform to the following applications and criteria:

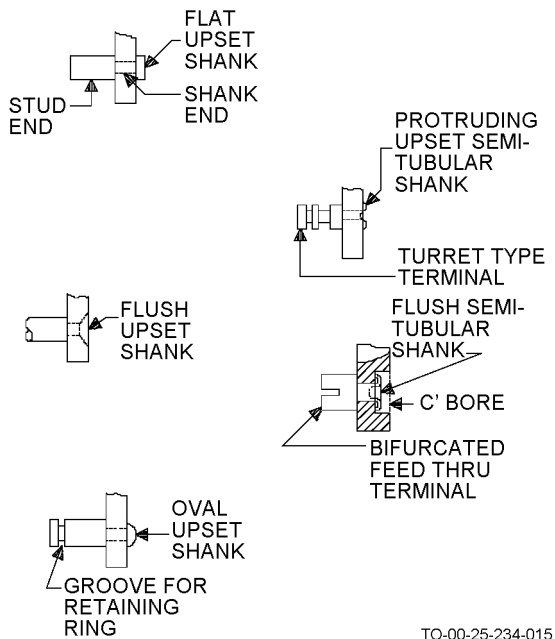

Figure 4-12. Typical Studs and Terminals

- The length of screws or bolts shall provide a minimum thread clearance of 1 1/2 threads and a maximum of 1 1/2 threads plus 1/8 inch beyond nut or adjoining parts, unless such projection hinders operation or violates design specification.
- Tapped holes, holes drilled and threaded with a tap, shall conform to specifications illustrated in Figure 4-14. As an example, determine the dimensions of a hole tapped in brass for a 1/2-inch diameter(s) bolt of 32 threads per inch (N). The holes threaded to a depth (C) of 7/8 inch, allows entrance length (A) of 3/4 inch and thread clearance (B) of 1/8 inch with an unthreaded portion (E) of 1/8 inch, the total hole depth (F) is one

inch. When completely tapped, deburr and clean the hole of chips, lubricant, and other foreign matter. Aluminum and other soft materials shall not be threaded for use as parts subject to frequent disassembly unless applicable official directives so dictate.

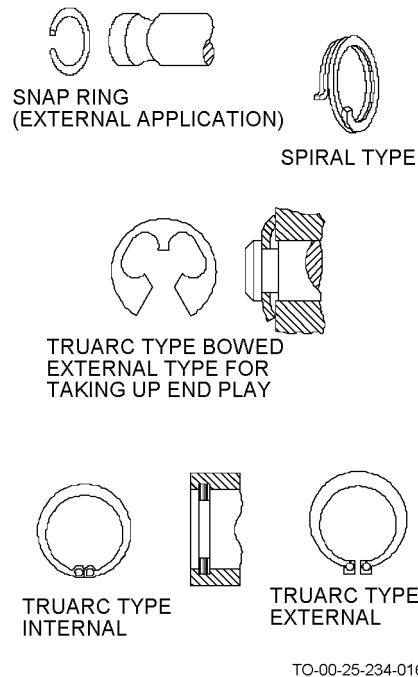

Figure 4-13. Typical Retaining Rings

- In addition to nuts which are fixed in place after the assembly of member parts, electronic equipment uses anchor nuts affixed to one member prior to assembly. Figure 4-15 illustrates anchor nuts which mount on a surface by riveting, bolting, or welding. If the nut and flange are the fixed type or one piece, the anchor nut requires precise alignment with mating parts prior to mounting. Other types of anchor nuts allow the nut to float in a retaining housing and do not require highly precise alignment before mounting. Clinch nuts and plug nuts (Figure 4-15) are similar to anchor nuts except that the clinch and plug nuts press into holes drilled or punched into one of the member parts.
- Locking nuts will be used to make threaded fasteners vibration proof. Locking nuts are divided into two general classifications, self-locking and externally locked. A widely used type of self-locking nut contains a captive nylon washer having an inside diameter slightly smaller than that of the locking nut. When turned onto a threaded fastener the nylon compresses, thereby, exerting pressure on the threaded fastener and preventing the locking nut from vibrating off. Self-locking nuts with nylon washers may be reused providing the threaded fastener cannot be turned past the nylon washer using finger pressure. Castellated nuts are a widely used type of externally locked locking nut. A castellated nut is notched to accept a cotter pin inserted through a hole in the mating threaded fastener.

ers. Regular nuts can be made locking by drilling the mated nut and bolt and inserting safety wire. Refer to Paragraph 4.6 for proper use of safety wire.

CAUTION

Lockwashers under compression will damage plastic or other soft materials, therefore, lockwashers shall not be used in contact with plastic or other soft materials.

- e. There are two basic types of washers: flat washers and lockwashers. Flat washers distribute the pressure of a tightened screw or bolt, protect the edge of a hole receiving a screw or bolt, and space or position parts. Lockwashers (Figure 4-16) prevent nuts from loosening due to vibration. When a lockwasher placed under the nut of a threaded fastener compresses, projections on the lockwasher grip the metal surface and nut securely. Use only plated bronze or corrosion resistant cadmium or zinc plated steel lockwashers.

- f. Setscrews hold parts on shafts. One setscrew shall hold a part on a shaft with a flat side. Two setscrews, displaced 90 to 120 degrees, are required to hold a part on a round shaft. Socket-head setscrews will conform to DWG AN565 or equivalent. Avoid use of fluted-head setscrews, smaller than size No. 6 unless specifically required by applicable directives.
- g. Self-tapping or sheet metal screws shall not be used if other suitable fasteners exist.
- h. Threaded, thin wall, self-locking metal inserts (in accordance with Specification MIL-N-25027) or helicoils shall be used where added strength is necessary or screw is subject to frequent removal or replacement. (TO 44H1-1-117 General Installation of Helicoil Inserts). Use this method only when design specifications prevents other methods.

Material	Entrance length for screws bolts, etc. A	Thread clearance at bottom of hole B	Thread length C	Unthreaded portion of hole E	Depth of drilled hole F
Aluminum	2D	4/N	2D + 4/N	4/N	C + E
Cast Iron	1 1/2D	4/N	1 1/2 + 4/N	4/N	C + E
Brass	1 1/2D	4/N	1 1/2 + 4/N	4/N	C + E
Bronze	1 1/2D	4/N	1 1/2 + 4/N	4/N	C + E
Steel	D	4/N	D + 4/N	4/N	C + E

D = DIAMETER OF FASTENER
 A = ENTRANCE LENGTH
 B = THREAD CLEARANCE AT BOTTOM OF HOLE
 C = TOTAL THREAD LENGTH IN HOLE
 E = UNTHREADED PORTION OF HOLE
 N = THREADS PER INCH
 F = DEPTH OF TAP-DRILL HOLE

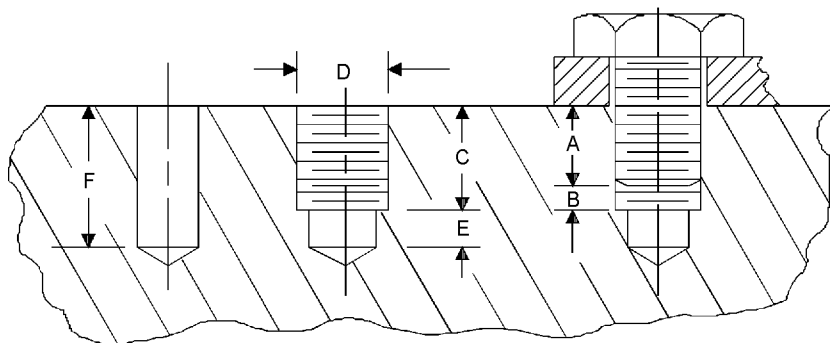

TO-00-25-234-017

Figure 4-14. Tapped Hole Specifications

TO 00-25-234

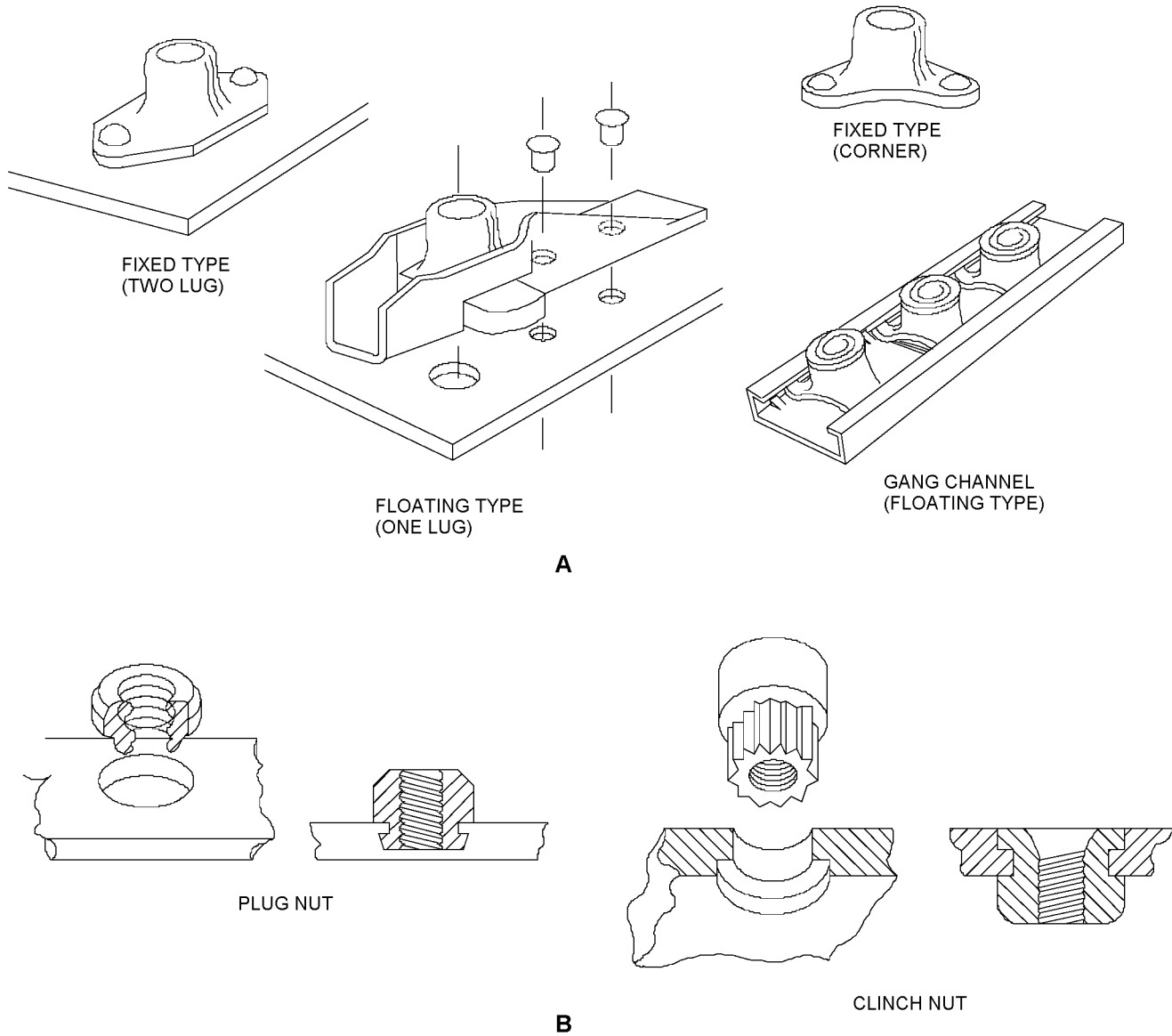

TO-00-25-234-018

Figure 4-15. Anchor Nuts, Clinch Nut, and Plug Nut

- i. The use of adhesive compounds, i.e Glyptol or Insulating Varnish NSN 5970-00-901-5331, PN 90-2, or equivalent for safety or retaining means, shall be limited to applications where no other satisfactory means exist.

4.6 SAFETY WIRING AND SAFETY CABLING.



- Do not wire electrical or RF connectors which have a mechanical lock, as lock wire will act against the locking feature.
- Use only new lock wire when replacing safety wired electrical connectors or emergency devices. Do not attempt to reuse the old lock wire.

NOTE

The term "Safety Wire" or "Wiring" as used throughout this chapter is used interchangeably with the term "Lock Wire" or "Wiring". Procedures which follow concerning safety or lock wire are not related to the type wire used as a seal on emergency devices which must be quickly released for use, or to indicate whether these devices have been tampered with or used.

Electric connectors, emergency devices and other pieces of electric equipment are secured with safety wire when specified by engineering drawings in order to prevent accidental loosening. Electric connectors are usually safety wired in areas of high vibration and in locations not readily accessible for periodic maintenance inspection. Safety cable may be used as substitute for lockwire to prevent loosening during service. Threaded parts, such as drilled-head bolts, fillister head screws, turnbuckles, thumb-screws, hose fittings and electrical connectors, plugs, caps, and similar items are within the scope of the safety cable application. For rules and guidelines for safety cable applications, refer to Chapter 11 of TO 1-1A-8. For safety wire applications, continue this chapter.

4.6.1 Material. For securing coupling parts of AN connectors, use corrosion resisting steel lock wire. In locations where the lock wire may come into contact with magnesium, use zinc coated carbon steel lock wire.

NOTE

Other wire may be authorized by specific applicable directives.

- a. Wire used for safety wiring purposes, in order of precedence, is as follows:

Wire-Steel: soft zinc coated; Specification AN-N-22.

Wire-Steel: corrosion resistant; Specification WWW-423.

Wire-Steel; zinc coated; type 2; annealed grade FS1010; Specification QQ-W-461.

- b. The size of wire used for safety wiring, in accordance with screw sizes, is as follows:

Nos. 2 and 4 screws	0.020 inch
Nos. 6 and 8 screws	0.031, 0.032, and 0.033 inch
Nos. 10 through 1/4 inch screws	0.041 inch

4.6.2 Twists Per Inch.

0.020 gauge wire:	9-12 twists
0.031, 0.032, 0.033 gauge wire:	7-12 twists
0.041 gauge wire:	7-10 twists

4.6.3 Double Twist Method. Use the double twist method of safety wiring, as illustrated in Figure 4-17 whenever possible.

4.6.4 Single Wire Method. Use single wire method of safety wiring as illustrated in Figure 4-18 only in the following cases:

- a. For all emergency devices.
- b. For safety wiring in areas difficult to reach.
- c. For small screws in a closely spaced pattern.

TO 00-25-234

4.6.5 Twisting With Pliers.**WARNING**

Eye protection shall be worn while installing or removing safety wire. Keep fingers away from jaws and cutting edge.

CAUTION

Make sure lock wire does not become kinked or nicked during twisting operation, and that plating on zinc coated wire is not damaged. If wire is damaged replace with new lock wire.

When lock wire is twisted by hand, use pliers for the final twists to apply tension, and to secure ends of wire. Cut off part of wire gripped by pliers to remove rough edges.

4.6.6 Twisting With Special Tools.**WARNING**

When using wire twisters and wire extends three inches beyond jaws of twisters, loosely wrap wire around pliers to prevent whipping and possible injury to personnel.

To twist lock wire with a wire twister (Figure 4-19):

- a. Grip wire in jaws of wire twister and slide outer sleeve down with thumb to lock handles.
- b. Pull knob; spiral rod spins pliers and twists the wire.
- c. Squeeze handles together to release wire.

4.6.7 Tightness of Wire. Install lock wire so that the wire will be in tension if the part loosens. Twist lock wire together so that it is tight, but do not overstress wire as it may break under load or vibration.

4.6.8 AN Connectors. To safety-wire AN connectors (Figure 4-21):

- a. Thread lock wire through wire hole in coupling ring.

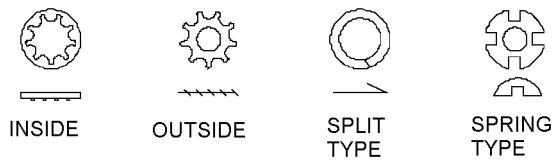

TO-00-25-234-019

Figure 4-16. Typical Lockwashers

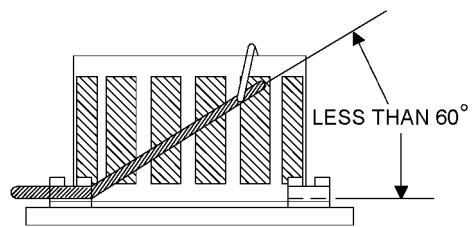

VERTICAL VIEW

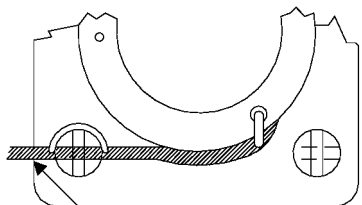

BEND PIGTAIL AROUND SCREW
TO PROTECT PERSONNEL

HORIZONTAL VIEW

TO-00-25-234-020

Figure 4-17. Double Twist Safety Wiring

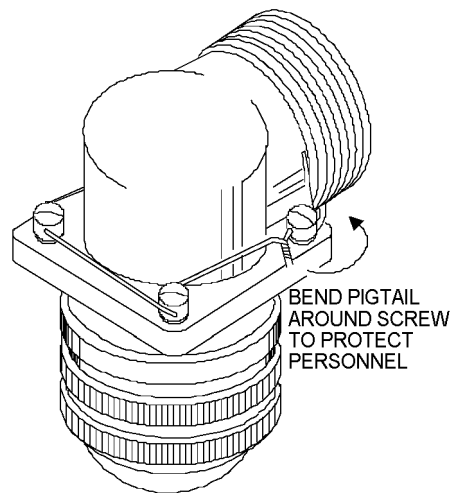

TO-00-25-234-021

Figure 4-18. Single Wire Method

TO 00-25-234

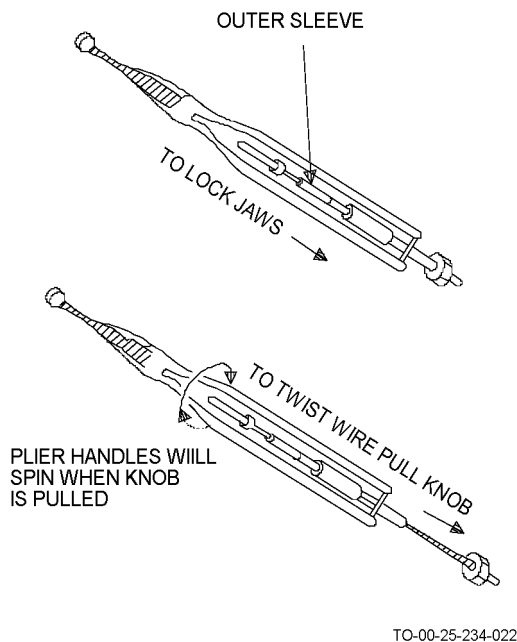

TO-00-25-234-022

Figure 4-19. Use of Wire Twister



Use MS20995 0.020 lockwire only. Larger lockwire can break out the hole in the coupling ring.

NOTE

If connector plug to be safety wired does not have a wire hole, remove coupling nut and drill a No. 56 (0.046 inch) diameter hole diagonally through edge of coupling nut.

- b. Twist wire, under slight tension, approximately 6 to 8 turns per inch, by hand, or by special tool. Twist wire clockwise to cause a tightening effect.



Do not “back off” or over-torque mounting fillister head screws, in order to align holes for safety wiring.

- c. Pull one end of twisted wire through hole in drilled fillister head screw on mounting flange of connector. Use a fillister head screw so located as to allow a degree or smaller angle of the wire (Figure 4-17).
- d. Form “pigtail” 1/4 to 1/2 inch (3 to 6 twists) clockwise with pliers.

- e. Bend “pigtail” back toward body of connector, to prevent it from injuring personnel.
- f. If no screw is available for attaching lock wire secure wire to drilled hole in structure not more than 6 inches from connector (Figure 4-21).

4.6.9 **Split-Shell Assemblies.** Split shell connectors made by Amphenol are held together by two fillister head screws. Secure these screws as follows (Figure 4-22):

- a. Draw wire through hole in one screw.
- b. Cross wire from left to right between screws and draw through second screw.
- c. Twist wires together with pliers, and bend back.

4.6.10 **Solid-Shell Angle Plugs.** Angle plugs with solid back shells as made by Amphenol are in two parts, held together by four screws through mating flanges. Safety wire these screws with a single wire as shown in Figure 4-18.

4.6.11 **V-Band Couplings.** The instruction given is a brief outline of precautionary procedures and installation techniques to improve the reliability of V-couplings used in electronic equipment.

NOTE

The instructions are general and are applicable except when otherwise specified in the manuals for the specific aerospace vehicle. If there is a conflict between this manual and the manuals for a particular aerospace vehicle, subsequent technical orders, technical notes, or change orders, the latter will govern in all cases.

4.6.11.1 **Pre-installation Checks.** Exercise particular care during handling and installation to ensure that flange faces are not scratched, distorted or deformed.

- a. Clean flange faces free of dirt, grease and corrosion.
- b. Use care during the installation to ensure mating and alignment of flanges. A poorly-fitted joint requires excessive torque on the T-bolt to close the joint and imposes structural loads on the V-Band Clamp. Refer to the applicable Maintenance, Overhaul, or Service Instructions for joint and clearances.
- c. Clean the flange faces and inspect every time a clamp is removed. Clean the flange faces by wiping with a clean cloth. Do not use a wire brush to remove dirt.

4.6.11.2 **Installation.** Check the part number to ensure that the proper coupling is being installed.

- a. When re-installing a used coupling, check it for twist or distortion. Visually check the V-section for spreading at the open ends or other signs of distortion. Check spot weld or rivets for condition and security. The corner radii should be carefully checked for tool marks and cracks. Couplings in poor condition should be replaced.
- b. Check the threads on the T-bolt for wear and condition. If there is any sign of wear, galling or deformation, install a new T-bolt or coupling.
- c. Check the T-bolt for straightness; however, if it is bent it will be necessary to determine if the bend is intentional. Some small diameter couplings have curved T-bolts. Check the applicable illustrated parts breakdown for part identification. If in doubt, install a new T-bolt or coupling.
- d. The trunnion and latch should be checked for freedom of movement or other evidence of overloading.
- e. Avoid twisting, spreading or bending of the coupling when positioning the coupling on the joint.

4.6.11.3 Gaskets. When gaskets are used in the joint, exercise particular care in handling to avoid nicks and burrs on the gasket surfaces. Whenever a joint is disassembled after service operations, a new gasket should be used when reassembling to ensure maximum sealing efficiency. Exercise care to ensure that the gasket is properly seated.

4.6.11.4 Torque. Before installing the coupling, determine the correct torque for tightening the T-bolt nut by referring to the applicable Maintenance, Overhaul, or Service Instructions. Correct torque is vital in assuring reliability of the coupling.

4.6.11.5 Nuts. Several different types of nuts are used on the T-bolts. If a nut is lost or damaged, replace it with a clean and undamaged identical type nut. Be careful to match the T-bolt threads.

4.6.11.5.1 To install the coupling, locate the coupling over both flanges and press the coupling closed. Engage the quick coupler latch or install the nut. Be sure the T-bolt is correctly seated. Tighten the nut to about two-thirds of the specified torque and tap the coupling lightly around the circumference of the band with a plastic or other non-metallic mallet. On multibolt assemblies, nuts should be drawn up equally. Continue, alternately tightening and tapping where possible until the torque indicated on the torque wrench stabilizes at the specified value. Exercise caution to avoid over torquing.

WARNING

Use of improper size clamp, overtightening T-bolt or missing, defective gasket could cause separation of the coupling and injury may result.

4.6.11.5.2 Do not attempt to seal a leaking joint by overtightening the T-bolt. Check for a wrong coupling, a damaged flange, or a defective gasket.

TO 00-25-234

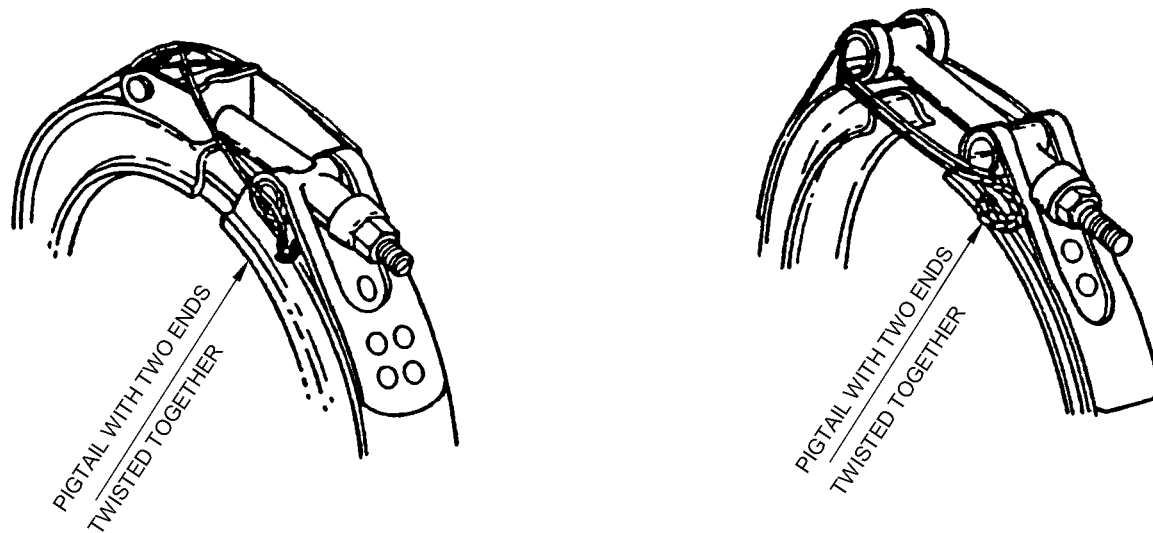

TO-00-25-234-023

Figure 4-20. V-Band Coupling Safety Wiring Techniques

4.6.11.5.3 To prevent complete separation of the joint in the event of T-bolt failure, lock wire the coupling. Lockwire shall be Federal Specification QQ-W-423 type and diameter shall be 0.032 to 0.041 inch steel safety wire. Quick disconnect V-Band couplings are required to be lock wired by the X method as per Figure 4-20. Unless specifically directed by an applicable Maintenance, Overhaul, or Service Instructions, the captive T-bolt is not required to be safetied.

NOTE

When safety wire is required, Captive T-bolt V-band may be lock wired using either method in Figure 4-20. Lockwire will be installed through

band loops which retain the T-bolt and T-bolt trunion or quick disconnect coupler, see Figure 4-20. A double loop of single strain wire is required. Install first loop firmly in place, second loop should not be over stressed by twisting end of wires.

4.7 CLAMPS.

Any electrical part that is not self-supporting must be supported by a holder or clamp. Figure 4-24 illustrates typical clamps used for holding cables, tubes and large capacitors. When a replacement part is physically smaller, the original clamp will be removed and replaced with one that fits.

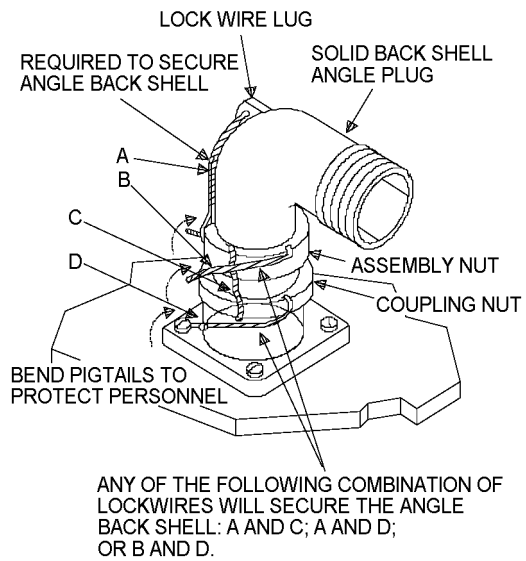

Figure 4-21. Safety Wiring AN Connectors

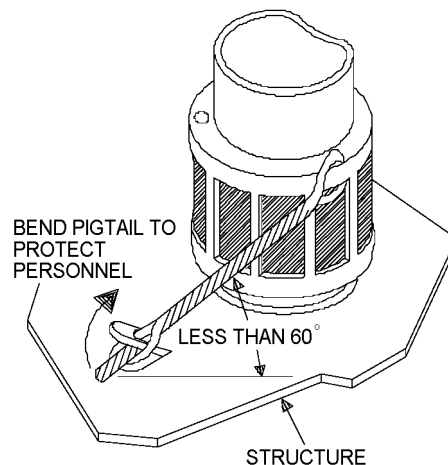

Figure 4-22. Safety Wiring AN Connector to Structure

TO 00-25-234

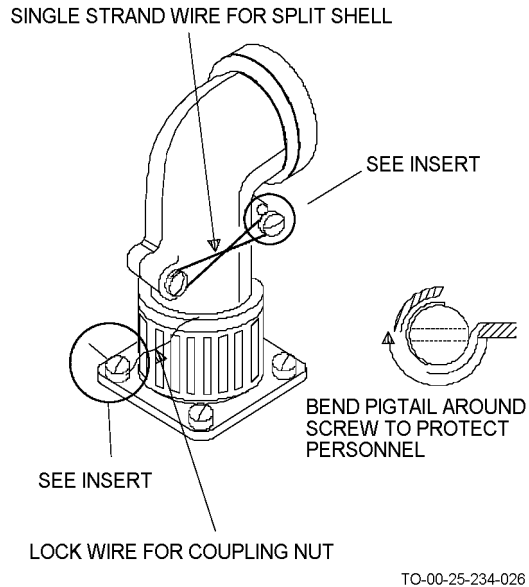

Figure 4-23. Safety Wiring AN Split-Shell Assembly Screws

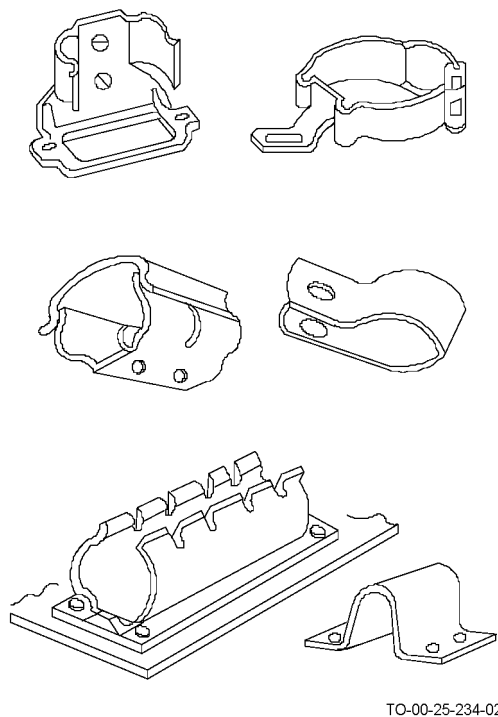

Figure 4-24. Typical Clamps

4.8 WELDING.

Common methods of thermally bonding metals together are soldering and welding. Soldering is described in TO 00-25-259. Due to the specialized knowledge, equipment, and work

area required, welding is not normally accomplished by the electronics technician. When welding is required during maintenance or repair of electronic equipment, the electronics technician shall route the equipment through proper channels to appropriate facility.

4.9 WIRING.

Wiring used in the repair or overhaul of electronic equipment shall at all times be of sufficient size and cross section to provide ample and safe current carrying capacity.

4.9.1 Type of Wire. Whenever practical, use flexible stranded wire. Use solid wire only when wiring is insulated and held firmly in place so that failure of the equipment or excessive motions of the wiring will not result from normal in-service vibrations and shock. Do not use wire smaller than AWG No. 22 unless a specific official directive so prescribes. In no event shall the size of wiring used impair equipment performance.

4.9.2 Protection. Protect wiring which passes through metal partitions or shields less than 1/8 inch thick by installing appropriate grommets in the holes or by punching and rolling the hole. Protect wiring which passes through metal partitions or shields more than 1/8 inch thick by installing grommets in the holes or rounding edge of holes to a minimum radius of 1/16 inch. Route conductors and cables to avoid contact with heated or abrasive areas. Insulate unused conductors in a cable or harness at both ends and securely tie to the cable or harness body.

4.9.3 Marking. Unless otherwise specified by official directive identify non-coded wire used in the repair and maintenance of electronic equipment as follows:

- a. The preferred method, using a wire stamping machine, marks the non-color coded wire at intervals along the full length of the wire with a "letter" color code and the wire number from the equipment wiring diagram. For example: BK-111 (black wire No. 111); BL-121 (blue wire No. 121); R-Y-24 (red wire with yellow tracer No. 24). The intervals between the identification codes placed on the wire are determined by the length of the wire, but are limited to a maximum of 15 inches. In addition stamp wires within three inches of each junction (except permanent splices), and at each terminating point. Stamp wires which are 3 to 7 inches long in the center. Wires less than three inches long need not be stamped.
- b. An alternate method uses the same identifying letter and number code, but affixes the identification at each end of the wire close to its termination point.

c. "Letter" color codes to be used are:

BK-black	OR-orange
BL-blue	R-red
BR-brown	V-violet
GR-green	W-white
GY-gray	Y-yellow

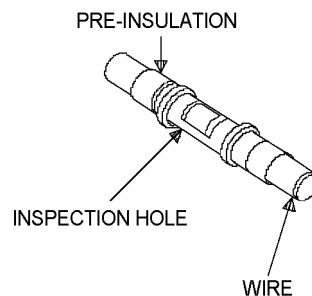

TO-00-25-234-028

Figure 4-25. Pre-Insulated Permanent Copper Splices

Table 4-2. Pre-Insulated Copper Splices and Crimping Tools

Splice wire size range	Hand crimping tools	Wire stripping lengths
AMP:		
22-18 (Red)	48430 49556*	3/16 inch
16-14 (Blue)	48431 49557*	3/16 inch
12-10 (Yellow)	59062* 59118	9/32 inch
Burndy:		
220-14 (White)	MR8-1A* MR8-33S	1/4 inch
12-10 (White)	MR8-1A* MR8-33S	5/16 inch

* Remove stop-plate before use on splices.

4.9.4 **Permanent Splicing.** Unless otherwise specified by specific equipment technical order or official directive, broken wires shall be spliced using pre-insulated permanent copper splices (Figure 4-25). Pre-insulated, permanent copper splices are used to join small copper wires of sizes 22 through 10. Note that splice pre-insulation extends over the wire insulation. Each splice size can be used for more than one wire size (Table 4-2). AMP (Aircraft Marine Products) splices are color-coded. The splices of other manufacturers are insulated with white plastic. The crimping tools most commonly used for each splice are also listed in Table 4-2. For best connections use only tools listed for each splice. The crimping procedures for permanent splices vary only slightly from those for pre-insulated copper terminal lugs. Variations are:

- Crimping operation must be done twice, once for each end of splice.
- Wire stripping lengths are different and are given in Table 4-2.
- When using tools where stop-plate is removed insert each splice so that splice barrel is centered under tool indenter.

- AMP tools 48430, 48431, and 59118 have splice locators. Insert splice in tool so that locator fits into gap between splice barrels.
- Number 22 wire can be spliced with No. 16-14 splice by stripping double length and folding bare conductor back on itself. Use care not to break strands.
- Insert wires and observe that each stripped wire is visible through inspection hole in splice.
- After crimping check that wire ends are still visible through inspection hole.

NOTE

Do not splice aluminum wires. Damaged aluminum wire must be replaced. See applicable sections in TO 1-1A-14 Series Manuals for off-equipment electrical and electronics repair.

4.9.5 **Emergency Splicing.** Broken wires can be spliced in an emergency by the use of terminal lug from which the tongue has been cut off, or by soldering together the broken wire, and applying potting compound.

TO 00-25-234

a. Splicing with terminal lug barrel. When a permanent splice is not available, the barrel of a terminal lug can be used.

- (1) Select a terminal lug (Figure 4-26) with a barrel large enough to accommodate both wires.
- (2) Install a piece of insulation sleeving about 1 inch longer than the terminal lug barrel, and of the proper diameter to fit loosely over the insulation, on one piece of the broken wire.
- (3) Cut off the terminal lug tongue.
- (4) Strip the wires.
- (5) Insert the wires from opposite ends of the barrel so that each wire protrudes through the barrel 1/32 inch.
- (6) Crimp the barrel in the center.
- (7) Slide the sleeving down over the connection so that it extends about 1/2 inch past each end of the crimped barrel and then tie it with nylon cord at each end.

WARNING

Avoid breathing fumes generated by soldering. Eye protection is required. Good general ventilation is normally adequate.

b. Splicing by soldering. When neither a permanent splice nor a terminal lug is available repair a broken wire as follows (Figure 4-27):

- (1) Install a piece of plastic sleeving about 3 inches long, and of the proper diameter to fit loosely over the insulation, on one piece of the broken wire.
- (2) Strip approximately 1 1/2 inches from wire on each side of break.
- (3) Lay the stripped ends side by side and twist one wire around the other with approximately 4 turns.

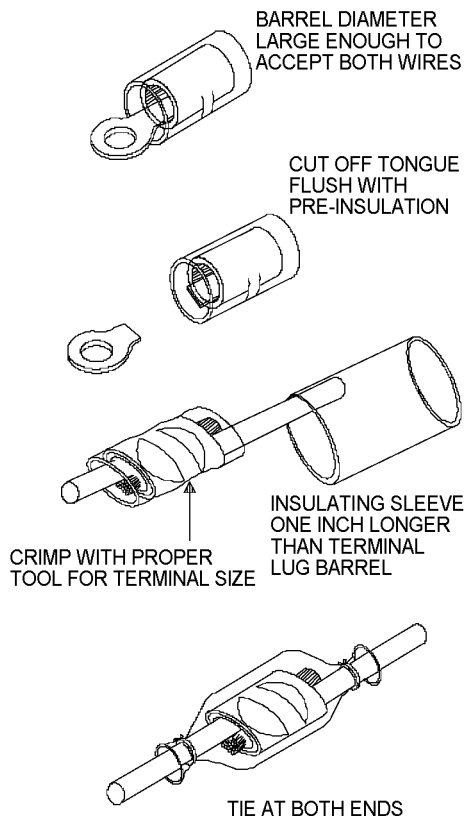

TO-00-25-234-029

Figure 4-26. Terminal Lug Barrel Splice

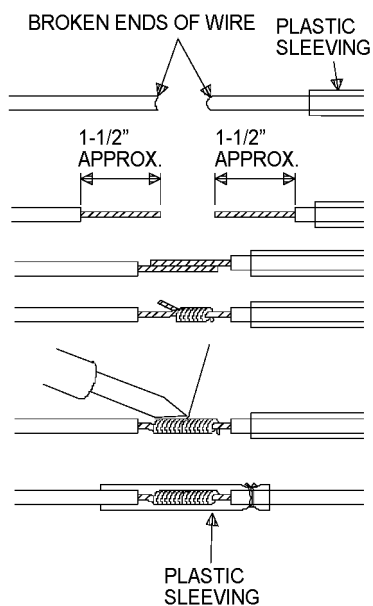

TO-00-25-234-030

Figure 4-27. Splicing Broken Wire by Soldering

- (4) Twist free end of second wire around first wire with approximately 4 turns. Solder wire turns together, using 60/40 tin-lead rosin core solder.
- (5) When solder is cool clean the connection with solvent, refer to TO 00-25-259, then draw sleeve over soldered wires and tie at both ends. Tying of both ends is not required whenever shrinkable tubing is used. In this case the tubing when heated will shrink and form to the diameter of the wire.

4.10 SHIELDED AND COAXIAL CABLE.

Shielded cable (unprotected by outer insulation) used inside electronic equipment will be routed and secured in such a manner as to preclude the possibility of contact with exposed wires and terminals. The shield shall be bonded to the chassis, unless connected to an "above ground" equipment or assembly. Shielded cables, used externally to electronic equipment, shall be bonded to the metal shell of each connector, and shall connect to a ground lead in the cable, providing conffliction with a detailed design specification does not result.

4.10.1 Removing Insulation.



Damage to outer jacket, shield, inner dielectric, and center conductor will occur if excessive heat or pressure is applied using thermal strippers.

Figure 4-28 illustrates some shop aids which can be used to strip insulation from coaxial cable without damaging shield or center conductor.

4.10.2 Connector Termination. Shielded and coaxial cables can be terminated in a variety of types of connectors. TO 1-1A-14, provides connections for specific types of con-

TO 00-25-234

nectors. N series connectors represent a typical connector termination for coaxial cable. To attach an improved N connector to coaxial cable (Figure 4-29):

NOTE

Nicked, scraped, broken, or otherwise damaged shields are not acceptable.

- a. Remove 9/32 inch of outer jacket, exposing shield.

NOTE

Nicked, scraped, broken, or otherwise damaged shields are not acceptable.

- b. Comb out shield and strip dielectric to 1/8 inch from end of jacket, exposing 5/32 inch of center conductor.

NOTES: (Reference Figure 4-28.)

- (1) Stripping-string tool can be made in several styles to fit different applications, and can be made in the size needed. Three styles are illustrated.
- (2) Use Dacron or nylon string, the size determined by the size cable to be cut. It is necessary to scribe a guiding mark around hard rubber or plastic insulation; this is not necessary for soft insulation. Make loop around cable with string. Position string in scribed indentation if used. Adjust string until the slack is just out. Use sawing motion cut through, then remove insulation.

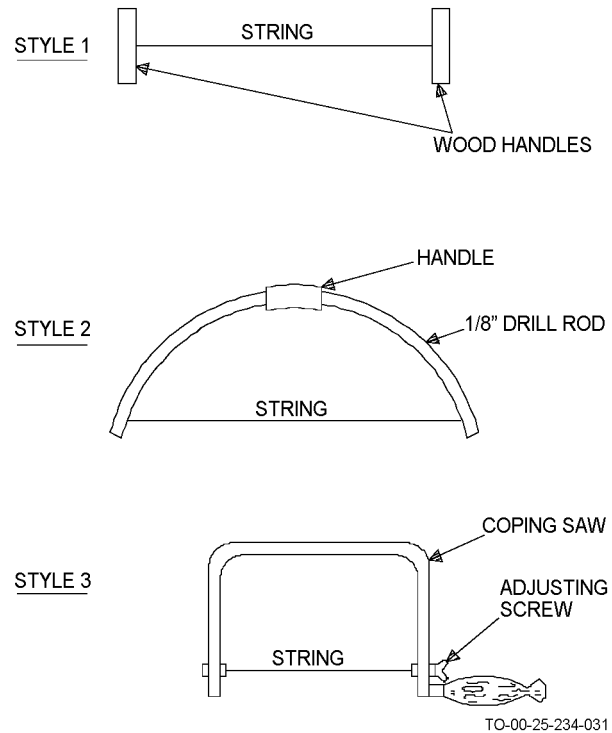

Figure 4-28. Shop Aids for Stripping Insulation from Coaxial Cables

- c. Disassemble nut, gasket and sleeve clamp from plug or jack body.

- d. Taper shield toward center conductor, and slide nut and gasket, in that order, over tapered shield onto jack. Make sure grooved side of gasket faces away from nut. Then slide sleeve clamp over tapered shield until clamp inside shoulder butts flush against cut end of jacket.
- e. Fold shield strands back over sleeve clamp taper without overlaps. Trim shield with scissors, so that strands end at end of clamp taper.
- f. Check that exposed dielectric is 0.045 inch beyond shield.
- g. Tin center conductor.
- h. Tin inside of contact (male or female).



Be sure that correct contact is being used; a male contact always goes into a plug body, and a female contact always goes into a jack body.

- i. Slip contact over center conductor so that contact butts flush against dielectric. Solder using a clean, well-tinned soldering iron: contact must still be flush against dielectric after solder has cooled; if it is not, remake the joint.
- j. Push cable assembly into connector body as far as it will go. Slide gasket into connector body. Be sure knife edge of sleeve clamp seats into groove of gasket. Then, slide nut into connector body and fasten body in vise. Start nut by hand, tighten with end wrench until moderately tight.
- k. RF connectors should be physically tight on their coaxial cable. Improperly fitting RF connectors will allow movement that degrades the electrical connection by bending, nicking, and breaking the braided shield wires. This can cause premature failure or equipment damage if the cable is used in a transmitting system. Degraded signal carrying capability can occur in a receiving or data transfer system. If any rotational movement is found between the RF connector and cable, the connector should be replaced.

4.10.3 Grounding Sheath Termination. When shielded or coaxial cable is not used with a connector the preferred method of terminating the shield is by crimping it, with or as required, between two sleeves (or ferrules). The procedure is as follows:

NOTE

If equipment manual requires soldering of pigtail wire to shield, proceed to Paragraph 4.10.4. If equipment manual requires braid fold-back dead-ending of shield without sleeves (ferrules), proceed to Paragraph 4.10.4 Step d.

- a. Strip off shielding braid (and outer jacket if present). Length to be stripped is determined by length of unshielded conductor necessary for making connections.
- b. Strip outer jacket (if present) and additional 1/2 to 3/4 inch.
- c. Measure outside diameter (OD) of primary insulation.
- d. Add 0.005 inch minimum to OD and select inner sleeve having the nearest larger inside diameter (ID) from Table 4-3.

NOTE

Inner and outer sleeves should be selected from the same manufacturer at all times.

- e. Note OD of inner sleeve selected and add 0.025 inch minimum to it to allow for thickness of shielding braid. Add an extra 0.030 to 0.040 inch to allow clearance for a No. 20 or No. 18 ground wire if required. From Table 4-4 select an outer sleeve, with the above dimension as minimum ID.
- f. Slide outer sleeve back over insulation and braid.
- g. Rotate cable with circular motion to flare out braid.
- h. Slip inner sleeve under braid so that about 1/16 inch of sleeve sticks out beyond braid.

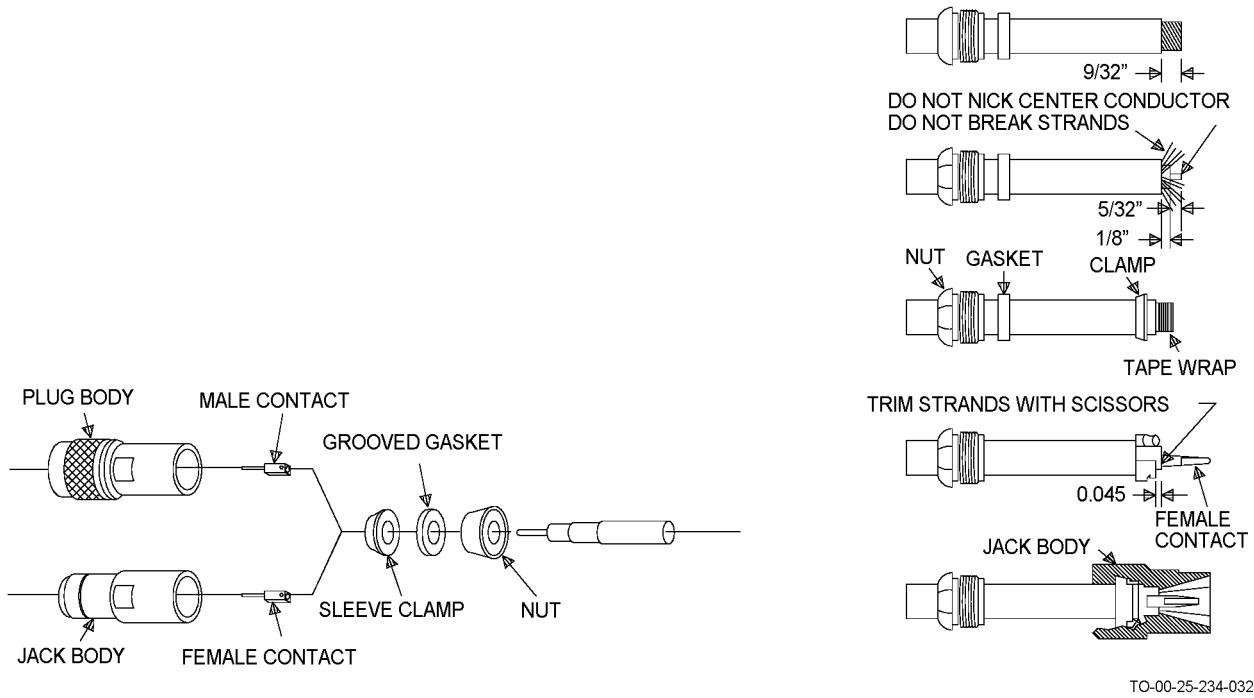
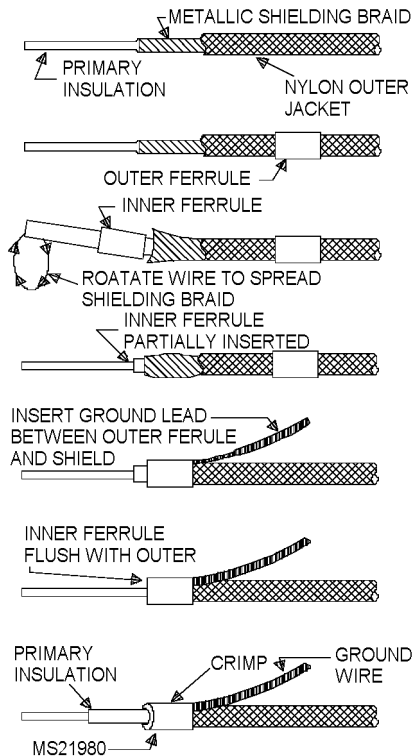

Figure 4-29. Attaching Improved N Connectors to Coaxial Cable



TO-00-25-234-033

Figure 4-30. Grounding Sheath Termination for Shielded Wire

Table 4-3. Shielded Wire Terminations, Inner Sleeves

OD Under Shield	Inner Sleeve		Thomas & Betts GSB Number	Burndy YPF Number
	ID	OD		
0.070-0.075	0.080	0.103	-	6G3
0.075-0.085	0.090	0.113	-	6G4
0.085-0.091	0.096	0.119	096	-
0.091-0.096	0.101	.0124	101	6G5
0.096-0.014	0.109	0.131	109	6G8
0.104-0.110	0.115	0.146	-	76P2
0.110-0.119	0.124	0.145	124	8G2
0.110-0.120	0.125	0.156	-	81P2
0.119-0.123	0.128	0.152	128	-
0.123-0.129	.0134	.0156	134	-
0.129-0.144	0.149	0.179	149	-
0.129-0.145	0.150	0.181	-	95P2
0.145-0.151	0.156	0.191	156	102P2
0.151-0.160	0.165	0.194	165	-
0.160-0.170	0.175	0.215	175	-
0.170-0.175	0.180	0.204	-	111P2
0.175-0.182	0.187	0.217	187	-

Table 4-3. Shielded Wire Terminations, Inner Sleeves - Continued

OD Under Shield	Inner Sleeve		Thomas & Betts GSB Number	Burndy YPF Number
	ID	OD		
0.182-0.189	0.194	0.225	194	124P2
0.189-0.200	0.205	0.245	205	-
0.200-0.214	0.219	0.250	219	-
0.214-0.220	0.2225	0.254	225	-
0.220-0.227	0.232	0.263	232	-
0.227-0.255	0.261	.0297	261	161P2
0.225-0.270	0.275	0.306	275	-
0.270-0.276	0.281	0.331	281	-
0.276-0.282	0.287	0.327	287	-
0.282-0.292	0.297	0.336	297	188P2
0.292-0.307	0.312	0.362	312	-

CAUTION

- Examine assembly to make sure that shield braid and ground wire come through under the outer sleeve.
 - Every extra connection in a coaxial cable means a loss of efficiency. Repaired coaxial cables shall be replaced at earliest possible time.
- Insert stripped ground wire under outer sleeve (if required) and slide both forward over braid and inner sleeve until only 1/32 to 1/16 inch of inner sleeve and braid protrude. Ground wire may extend from front or back of outer sleeve as required.
 - Crimp with hand tool and correct die selected from Table 4-4.

Table 4-4. Shielded Wire Terminations, Outer Sleeves and Installing Tools

Outer Sleeve		Installing Tools
Catalogue Number	ID (Inches)	
		Burndy
YPV 80	0.125	MR8PV
100	0.156	MR8PV, MR8PV-1
110	0.180	MR8PV, MR8PV-1
120	0.187	MR8PV, MR8PV-1
128	0.199	MR8PV, MR8PV-1
130	0.207	MR8PV, MR8PV-1
		MR8PV-1
140	0.219	MR8PV
150	0.235	MR8PV-1

TO 00-25-234

Table 4-4. Shielded Wire Terminations, Outer Sleeves and Installing Tools - Continued

Outer Sleeve		Installing Tools
Catalogue Number	ID (Inches)	
160	0.261	MR8PV-2
180	0.281	MR8PV-2
190	0.300	MR8PV-2
200	0.312	-----
220	0.344	MR8PV-4
240	0.375	
250	0.405	
Thomas & Betts		
GSC 149	0.149	WT 201
156	0.156	202
175	0.156	203
187	0.187	206
194	0.194	206
199	0.199	206
205	0.205	208
219	0.219	208
225	0.225	309
232	0.232	210
261	0.261	211
275	0.275	212
281	0.281	214
287	0.287	214
297	0.297	214
312	0.312	215
327	0.327	216
348	0.348	217
405	0.405	218

wires, as a group, with a minimum of one and one-half turns of insulating paper. Slide paper up to edge of cable sheath and pull shield over.

- d. Prepare a pigtail from AWG 26 insulated wire. Strip sufficient insulation from pigtail wire to allow wrapping of the exposed conductor one turn around cable shield plug 1/4 inch minimum overlap.
- e. With a blunt instrument make a small hole in the cable shield approximately 1/4 inch from end. Insert stripped end of pigtail wire under cable shield and out through hole in shield.
- f. Wrap stripped portion of pigtail conductor around outside of cable shield, approximately 1/4 inch from end of shield, and spot solder in place.
- g. Fold shield back over itself, covering pigtail conductor wrap around, (Figure 4-31). Tie shield fold-back down with fiberglass cord, if necessary. Solder shield fold-back to underlying shielding and to pigtail conductor. Make sure all shield braid ends are held flat and are soldered down. Remove any solder icicles. After soldering, remove paper (and cord if used).
- h. Continue pigtail spiral in direction of soldered wrap-around portion to form approximately one-quarter turn of insulated pigtail around bundle of cable wires; then loop back and spiral approximately one-quarter turn in opposite direction before terminating in connector contact.

NOTE

Following steps apply if equipment manual requires common point termination of shield pig-tails.

- i. If termination up to six shields, use methods described by either Step j or Step k. If terminating 7 to 13 shields use method described by Step k. If terminating more than 13 shields, use method described by Step l.
- j. Terminate up to six shields as follows:
 - (1) Using methods described in Step a through Step j, crimp shields in one set of sleeves (ferrules) (Figure 4-32).

4.10.4 Attaching Pigtail Wires to Cable Sheath. The following steps apply if equipment manual requires soldering of pigtail wires to cable sheath.

- a. Remove cable sheath to a point approximately 1/2 inch beyond point of desired breakout, measured from end of cable (Figure 4-31).
- b. Cut off exposed shield approximately 3/4 inch from edge of cable sheath.
- c. Push back and flare out exposed shield (Figure 4-31). To protect wires against heat of soldering, wrap cable

- (2) Tie wires into a group, using tie located approximately 1/2 inch behind the crimped sleeve, to avoid streaming of the crimp joint during connector assembly.

- k. Terminate up to 13 shields by crimping up to 7 pigtails in each side of a NAS 1388 splice (Figure 4-33).

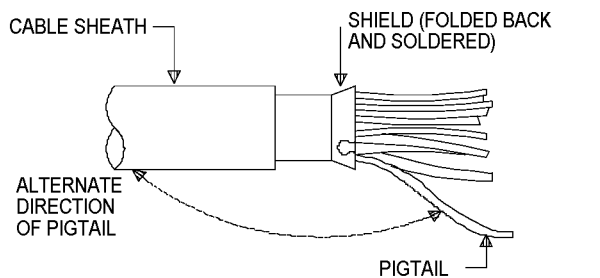
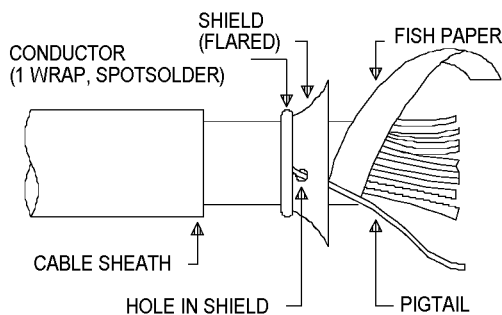
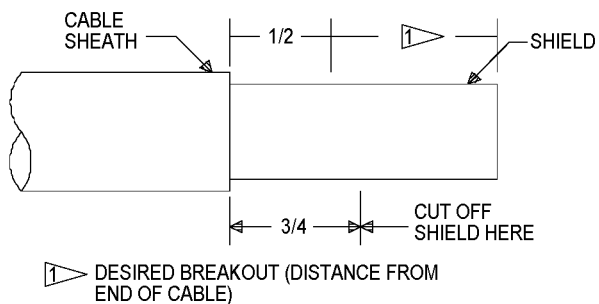

TO-00-25-234-034

Figure 4-31. Soldered On Pigtail Preparation

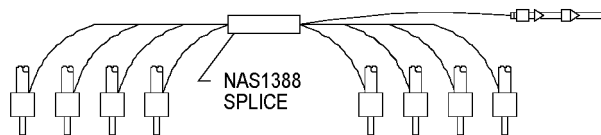

TO-00-25-234-035

Figure 4-32. Common-Point Pigtail Splice

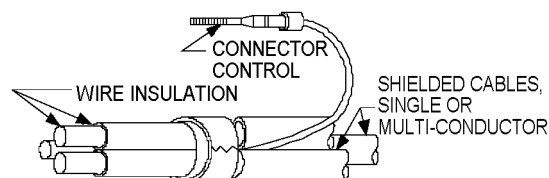

TO-00-25-234-036

Figure 4-33. Several Shields in One Set of Sleeves

- l. If more than 13 shields must be connected, use splice terminals and cascading pattern (Figure 4-34).

NOTE

Following step applies if equipment manuals require braid fold-back dead-ending of shield without sleeves (ferrules).

- m. Fold approximately 1/4 inch minimum of shield braid back over and onto jacket and insulate using heat shrink tubing (Figure 4-35).
- n. If jacket is not available to fold shield back over, shield may be folded back over a 1/2 inch length of heat shrink tubing. Insulate using heat shrink tubing.

4.10.5 Emergency Splice. Unless otherwise specified by design, several coaxial cables may be temporarily spliced by installing a matching plug and jack of the proper size and type at the severed point. Use procedures described in Para-

TO 00-25-234

graph 4.10.2, for connecting plug and jack to coaxial cable. Coaxial cable splices will be limited to a maximum of one splice every 30 feet.

4.10.6 Insulation Repair.**WARNING**

Epoxide casting resin is toxic to skin, eyes, and respiratory tract. Skin and eye protection required. Avoid skin contact. Good general ventilation normally adequate.

Unless otherwise specified by design or official directive, outer insulation of shielded cables exhibiting small nicks, cuts, or rubbed areas shall be repaired. Outer insulation of shielded cables in which shielding is damaged in any way shall not be repaired. Procedures for repair of power cord insulation shall be used to repair shielded or coaxial cable outer insulation. Epoxide casting resin shall be used to repair shielded or coaxial cable insulation. Repaired insulation shall not damage cable usefulness or equipment operation in any manner.

4.10.7 Stripping Coaxial Cable with Single Conductor Shield. When stripping coax, the objective is to separate the shield from center conductor without damaging the insulation on the center conductor. The coax is prepared in this way to enable its attachment to the appropriate connector. The procedure for stripping single conductor shield coax is as follows:

NOTE

To insure no damage is done to shield conductor, a 7X to 30X microscope should be used when stripping insulation.

- a. Mark the distance required for proper fit of lead to type of connector to be used. Next, strip about 1/8 inch off the coax exposing the shield and center conductor.
- b. Locate the side that the shield wire runs under the insulation, and bend shield back toward that side. Using just one side of a thermal stripper, start directly above

the shield from mark made in Step a, and melt away insulation above the shield. Next, repeat the procedure to melt finish off of the foil jacket. When complete, the foil jacket should be dull and thin above the shield.

- c. Gently peel shield wire back, the foil should split easily; if it does not, then check to make sure that finish is completely removed from foil jacket. If not, repeat procedure in Step b for removing finish from the foil jacket. Continue to peel the shield back to mark made in Step a. Then pull out center conductor.
- d. Trim insulation and foil jacket, making sure that it is trimmed evenly around the coax. Prepare coax for attachment to the connector to be used.

4.11 CABLE BINDING AND LACING.**NOTE**

Cable Binding and Procedures outline in this chapter is for off-equipment only applications. Refer to TO 1-1A-14 and weapon system specific technical order for the policy and procedures for On-equipment maintenance application.

Bind conductors into cables or harness whenever practical. Cables or harness are made by lacing or spot tying the conductors. Tighten lacing or ties sufficiently to prevent slippage of conductors, but do not cut or deform the conductor insulation. The methods of cable binding are as follows:

4.11.1 Cable Lacing. Lace cables with ribbon-type lacing cord in preference to round cord to minimize the possibility of insulation damage. One-eighth-inch nylon ribbon or equivalent is best suited for lacing. If ribbon cord is not available, use round cord of the following size:

Principal Cable Diameter	Cord Size
Up to 3/8 inch	No. 4
5/16 to 3/4 inch	No. 6
5/8 to 1 inch	No. 9
7/8 inch and over	No. 12

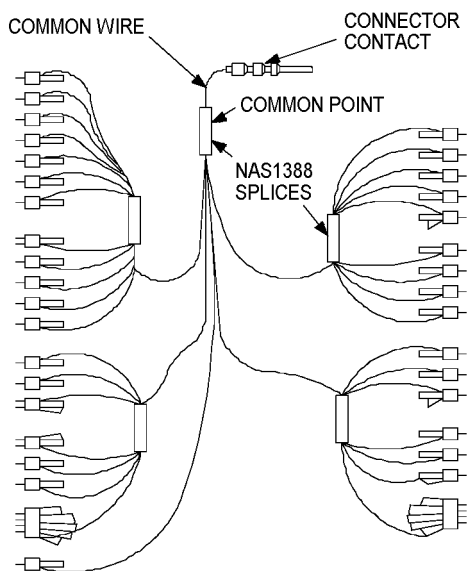

TO-00-25-234-037

Figure 4-34. Typical Cascading Pigtails

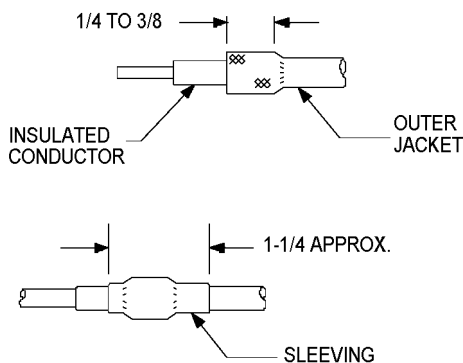

TO-00-25-234-038

Figure 4-35. Braid Dead-Ending

- a. Start lacing by cutting a length of cord 2 1/2 times the length of the proposed harness. Lay one end of the

cord alongside the principal cable, pointing in the direction of the proposed harness. Secure the cord end by winding approximately 4 turns of cord over it, and wrap until a total of 12 turns is wound about the principal cable (Figure 4-36). Secure the wrap with a lock stitch made by forming a loop, passing the cord over the loop, then through the loop, and finally pulling the cord tight. Lacing may also be started with a square knot, followed by two lock stitches (Figure 4-36).

- b. Form secure stitches by lacing the cord over the loop (Figure 4-37), never under (Figure 4-37), to form the so-called "lock stitch". The cord is thus locked under each loop. Lock stitches at approximately 1/2 inch intervals thereafter, secure other loops in the same fashion. The foregoing describes the "regulation cableman's knot", which is self-locking. As lacing advances, reform the wires to ensure a neat and firmly bound cable (Figure 4-37). Arrange conductors to lie parallel without crossovers except when twisting is required. All lacing should follow the top of the harness. All knots splices, or other irregularities should be hidden from view when cable is installed in the equipment.
- c. Terminate lacing by the procedure illustrated in Figure 4-38. Wrap four turns of cord adjacent to the last lock stitch. Form a separate piece of cord into 2-inch loop, and lay alongside the cable. Wrap 8 turns of lacing about the loop and draw the end of the lacing cord through the loop. Pull both ends of the loop to carefully draw the cord end underneath and out of the wrap. Pull the cord end tight, locking the wrap, and cut the end to approximately 1/8 or 1/4 inch. Lacing may also be terminated with a lock stitch followed by a square knot.
- d. Branches and sub-branches, including single leads, are usually referred to as "breakouts". Precede single-lead breakouts with a lock stitch, without variation in the distance between stitches (Figure 4-39). Lace any breakout of two or more wires. When a group of wires is branched from a cable (Figure 4-39), wrap a lock stitch 6 turns firmly about the principal cable adjacent to the new stitch; then make another lock stitch adjacent to the new turns. After a branch is secured, continue the running stitches along the main cable.

TO 00-25-234

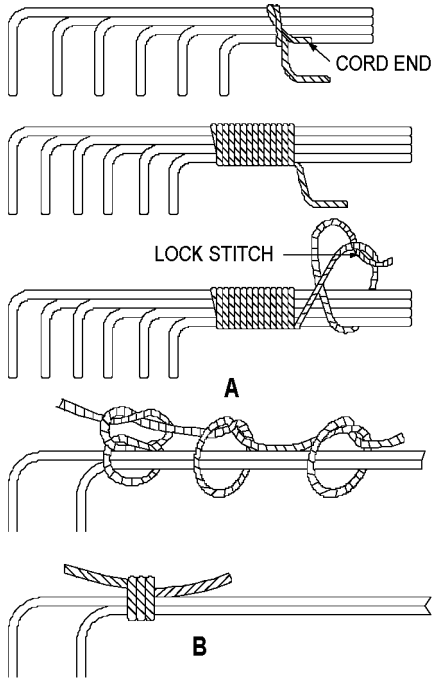

TO-00-25-234-039

Figure 4-36. Starting a Cable Lace

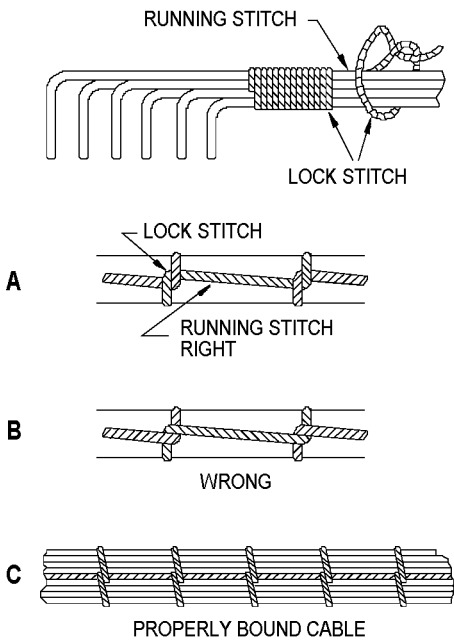

TO-00-25-234-040

Figure 4-37. Cable Stitching

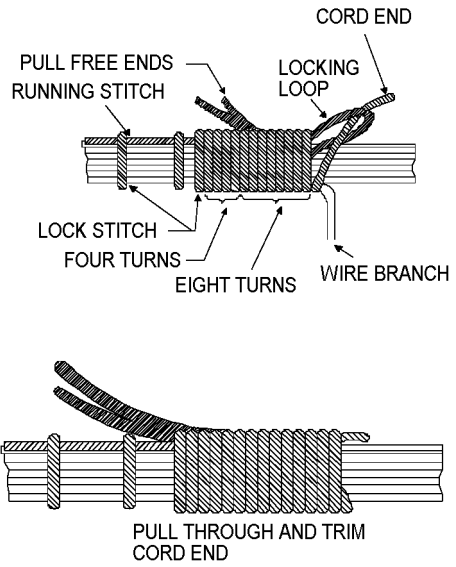

TO-00-25-234-041

Figure 4-38. Cable Lace Termination

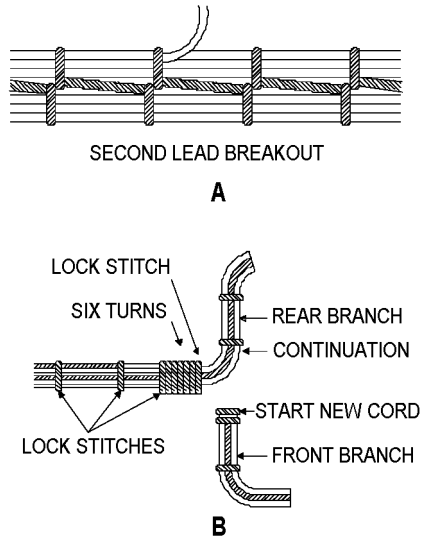

TO-00-25-234-042

Figure 4-39. Cable Branching

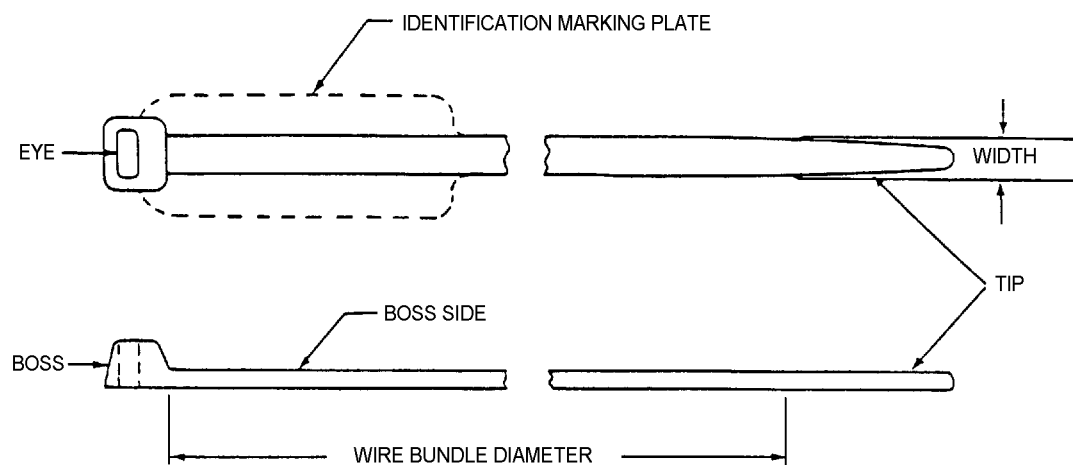

TO-00-25-234-043

Figure 4-40. Strap Configuration

Table 4-5. Self-Clinching Plastic Cable Straps and Installation Tools

MS Part Number	Max. Strap Width (Inches)	For Bundle Diameter (Inches)	MS Toll No. (MS90387-x)	Tension Setting
MS3367-1-*	0.190	1/16-1-3/4	-1	7
MS3367-2-	0.192	1/16-4	-1	7
MS3367-3-	0.310	3/16-3-1/2	-2	8
MS3367-4-	0.100	1/16-5/8	-1	2
MS3367-5-	0.146	1/16-1-1/4	-1	5
MS3367-6-	0.310	3/16-8	-2	8
MS3367-7-	0.192	1/16-3	-1	7
MS3368-1-	0.190	3/8-1-3/4	-1	7
MS3368-2-	0.190	3/4-4	-1	7
MS3368-3-	0.190	3/8-1-3/4	-1	7
MS3368-4-	0.190	3/8-1-3/4	-1	7
MS3368-5-	0.100	3/16-5/8	-1	2

* The (-9) designates the natural color strap and the (-0) designates the black color strap.

4.11.2 Self-clinching Cable Straps.



- Self-clinching straps are not to be used in temperatures which exceed 85 degrees centigrade.
- Self-clinching straps are not to be used on coaxial cables or bundles utilizing air or air foam dielectrics.

These are adjustable, lightweight, flat plastic straps used for

tying and supporting cable assemblies and wire bundles. The strap configuration is shown in Figure 4-40. The straps are of two types: (1) a MS3367 cable securing strap shown by the bold lines in Figure 4-40 and (2) a MS3368 identification and securing strap illustrated by the broken lines in Figure 4-40. These straps are available either in black or natural color. These straps are not to be used under the following conditions:

- a. In temperature environments which exceed 85 °C (185 °F).

TO 00-25-234

- b. On coaxial cables or bundles containing coaxial cable that contain air or air foam dielectric.

NOTE

Only black straps will be used in areas exposed to extensive periods of sunshine (ultraviolet light) or weather.

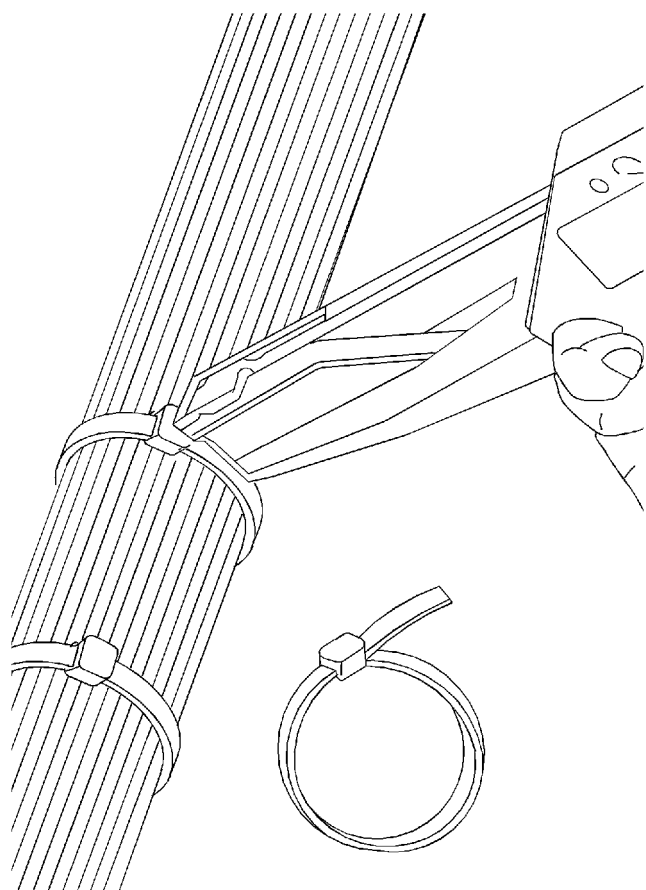

TO-00-25-234-044

Figure 4-41. Installing Self-Clinching Plastic Cable Straps

4.11.3 Cable Strap Installation. Using the Military hand tool listed in Table 4-5 or equivalent and illustrated in Figure 4-44 and Figure 4-45, perform the following:

- a. From Table 4-5 select a strap size and appropriate tool for the wire bundle diameter being secured. Refer to Paragraph 4.11.2 for restrictions on strap usage.
- b. Slip strap tip around the bundle with boss side up.
- c. Thread tip through eye then hand pull strap tight against the bundle.
- d. Adjust the tool index line to the tension locator value specified in Table 4-5. If standard changes in the tension adjustment knob does not align the index line with the required tension locator value, the knob may be pulled out and rotated until alignment occurs.
- e. Pass the free end of the cable tie through the slot in the end of the tool, then push tool snugly against the boss.
- f. While holding strap firmly against side of tool and tool facing squarely against boss, pump handle several times without fully activating the tool's cutting knife. Once the strap has been stretched to its maximum, squeeze handle slowly and firmly until strap is cut.

WARNING

The strap must be cut flush with the boss surface in order to eliminate painful cuts and scratches from protruding strap ends.

- g. If strap end is not flush with boss head, remove the strap and install a new strap in its place or trim the strap end flush.
- h. Pick up for appropriate disposal all broken straps and strap ends that were cut off.

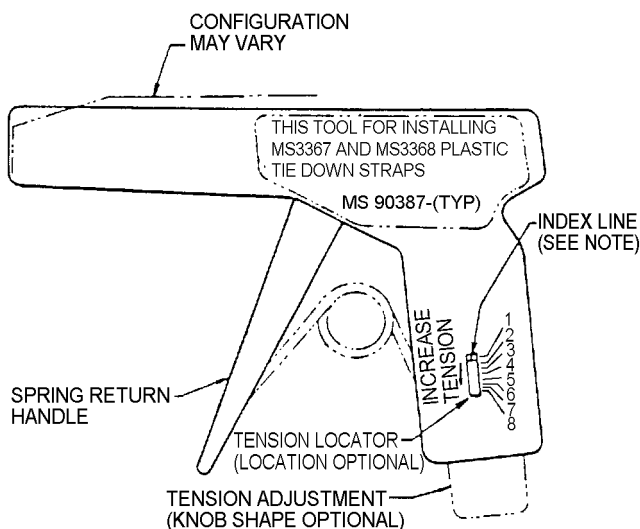

TO-00-25-234-045

Figure 4-42. MS90387 Adjustable Hand Tools for Installing Self-Clinching Plastic Tiedown Straps

4.12 HIGH TEMPERATURE PRESSURE-SENSITIVE TAPE.

WARNING

MIL-I-15126 insulation tape (including the glass fiber type) is highly flammable and should not be used in a high temperature environment. MIL-I-23594 insulation tape is designed for high-temperature operation (suitable for continuous operation at 500 °F) and should be used in all high temperature environments.

Use MIL-I-23594 high temperature insulation tape to tie all wire groups and cable bundles in areas where the temperature may go above 185 °F.

4.12.1 Spot Tying. Another procedure for lacing, spot tying (Figure 4-43) consists of making a series of individually bound wraps at equidistant points along the cable.

- Cut lacing cord 2 inches longer than the length required to make 12 turns about the harness.
- Form one end of the cord into a 1-inch loop, and place flat on the harness, parallel to the wiring.
- Wind 12 turns tightly over this loop, and at the last turn, push the cord end through the loop which extends from under the wrap.

- Pull the end of the looped cord until the loop is under the wrap, but only so far that the two loops intersect at the approximate center of the wrap.
- Trim loose cord ends.
- A carpet needle or shuttle facilitates feeding of the cord end and speeds lacing.

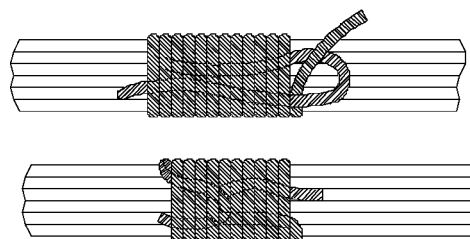

TO-00-25-234-046

Figure 4-43. Cable Lace, Spot Tie

4.12.2 Spot Tying with Nylon Straps.

WARNING

To prevent injury from protruding straps, use proper tools and cut straps flush with eye.

To perform spot tying with nylon straps (Figure 4-44). Slip the tie around the conductors, thread through the tie eye, and draw up tight. With a tie strap installation tool listed in Table 4-5 (or equivalent), engage the tie and clinch tight.

NOTE

Any of the following defects during harness and cable inspection.

- Frequent cord splices indicate that the cord was pulled too tight or that the cord size was too small for the diameter of the cable.
- Lacing cord should not become frayed. If fraying occurs, the original length of cord was excessive.
- Knots and splices should be concealed from top view.
- Wire insulation should not be broken, split, or frayed at its ends.
- Lacing should not be spattered by solder or scorched as a result of a soldering operation.

TO 00-25-234

4.13 CRIMPED ELECTRICAL CONNECTIONS.

Connections made in the repair or overhaul of electronic equipment shall be soldered as detailed in TO 00-25-259.

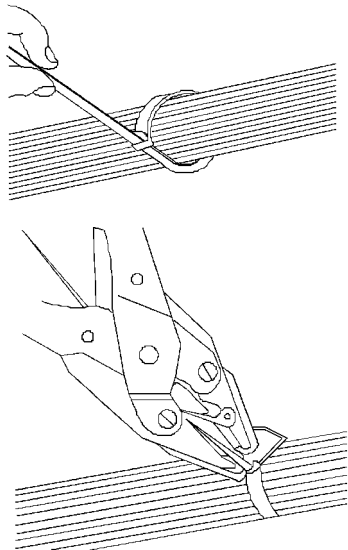

TO-00-25-234-047

Figure 4-44. Nylon Strapped Spot Tie

4.13.1 Types of Solderless Lugs.



Use copper terminations only on copper wire. Use aluminum terminations only on aluminum wire.

Various terminal lugs, designed to be crimped to electrical leads, provide excellent electrical and mechanical connections. Terminal lugs and splices are made of copper or aluminum and are pre-insulated or uninsulated depending on the application. Terminal lugs are available in three types: straight, right-angle and flag, for use under different space conditions. Figure 4-45 shows typical terminal lugs and splices and cutaway views of the completed junctions. Typical crimping tools are illustrated where they are mentioned in the procedures. Terminal lugs and splices are crimped (sometimes called staked or swaged) to the wires by means of hand or power crimping tools. Power tools are portable or stationary (bench-mounted). Solderless terminal lugs and splices most commonly used are made by AMP (Aircraft Marine Products), Burndy, and Thomas & Betts; this discussion is therefore limited to these items.

4.13.1.1 Pre-insulated Terminal Lugs. Small copper wires (sizes No. 22 through No. 10) are terminated with solderless pre-insulated straight copper terminal lugs conforming to Specification MIL-T-7928 and Military Standard MS 25036. As shown in Figure 4-46, the insulation is part of the terminal lug and extends beyond its barrel, so that it will cover a portion of the wire insulation, making the use of an insulation sleeve unnecessary. In addition, all pre-insulated terminal lugs contain an insulation grip (a metal reinforcing sleeve) beneath the insulation for extra gripping strength on the wire insulation. Pre-insulated terminals accommodate more than one size of wire; the insulation is color-coded to identify the wire sizes that can be terminated with each of the terminal lug sizes. Red insulation identifies lugs for wire sizes 18 through 22, blue insulation identifies lugs for wire sizes 14 and 16, and yellow identifies lugs for wire sizes 10 and 12.

4.13.1.2 Uninsulated Terminal Lugs.

WARNING

Acetone (O-A-51) is flammable and toxic to eyes, skin, and respiratory tract. Skin/eye protection is required. Avoid prolonged contact. Use only with adequate ventilation. Personnel injury could result.

Copper wires of sizes 4/0 through 8 and aluminum wires are terminated with solderless uninsulated terminal lugs. Uninsulated terminal lugs are insulated after assembly to wire by pieces of transparent flexible tubing called sleeves. The sleeve provides electrical and mechanical protection at the connection. When the size of sleeving used is such that it will fit tightly over the terminal lug, the sleeving need not be tied; otherwise, it is tied with lacing cord (Figure 4-47). Tight fitting sleeves are expanded in acetone solvent before installation. When the solvent evaporates, the sleeve will shrink tightly over the terminal lug. Aluminum terminal lugs differ from copper terminal lugs in that all aluminum terminals have an inspection hole, which permits checking depth of wire insertion (Figure 4-48) and the barrel of all aluminum terminal lugs is filled with a petrolatum-zinc dust compound. To prevent loss or contamination of compound, do not remove seal until just prior to crimping operation. The compound, by a grinding process during the crimping operation, removes the oxide film from the aluminum. The compound will also minimize later oxidation of the completed connection by excluding moisture and air. The compound is retained inside the terminal lug barrel by a plastic or foil seal at the end of the barrel.

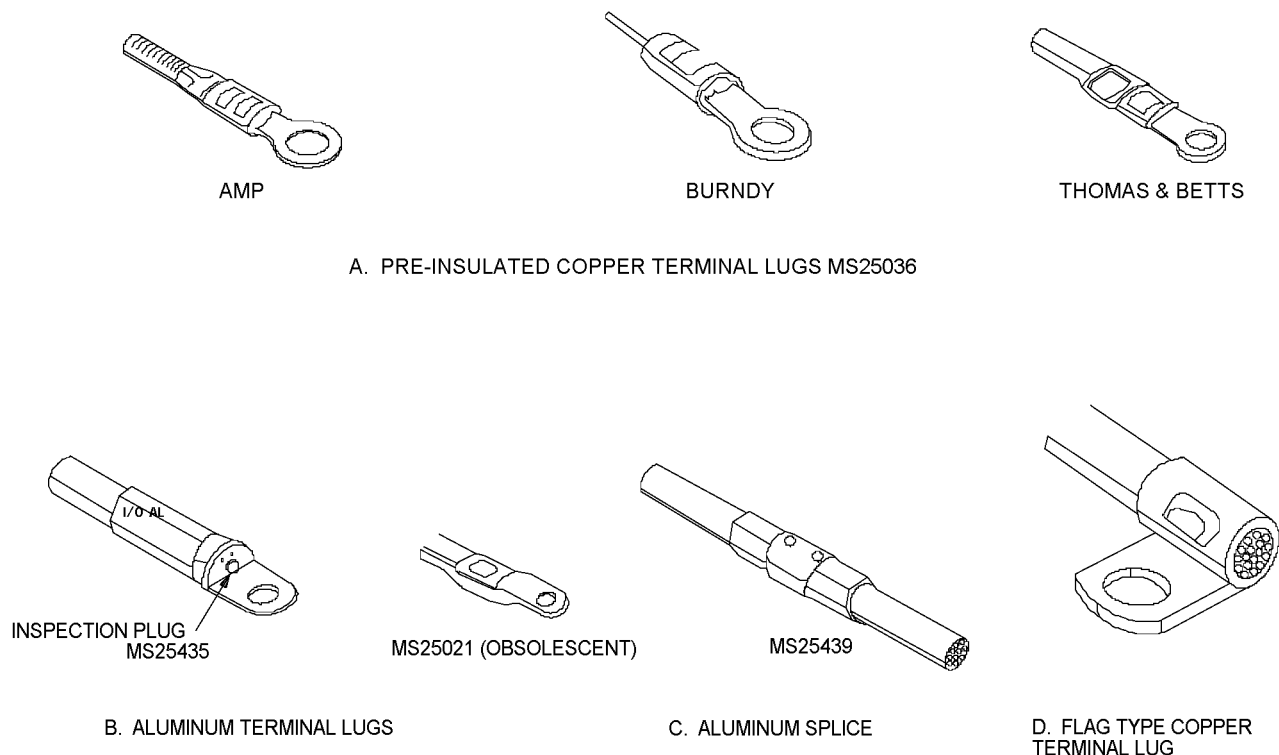

TO-00-25-234-048

Figure 4-45. Solderless Terminal Lugs

4.13.2 Crimping Tools. Hand, portable power and stationary power tools are available for crimping terminal lugs. These tools crimp the barrel to the conductor, and simultaneously crimp the insulation grip to the wire insulation. Crimping tools for copper and aluminum terminal lugs are different in the type of crimping insert used. However, the technique used in crimping is the same for either type lug. Military Standard tool MS 25037 is recommended for the standard copper lugs and Military Standard tools MS 25020 is recommended for straight and fly-type aluminum lugs. Other copper and aluminum lugs shall be crimped using the type tool recommended by the lug manufacturer.

4.13.2.1 Hand Tools. All hand crimping tools must have a self-locking ratchet. This ratchet prevents opening tool until crimp is complete and ensures proper crimping pressure. Hand tool sizes are identified as follows:

4.13.2.1.1 The Military Standard tool MS 25037 has nests identified by color-coded arrows (Figure 4-49).

4.13.2.1.2 AMP hand tools are used on one terminal lug size only. Each size tool is color-identified to match color of terminal lug insulation. Tool jaws are also size-marked (Figure 4-49).

4.13.2.1.3 Burndy tools have nest which are size-marked and color-coded at each opening (Figure 4-49).

4.13.2.1.4 The Thomas & Betts tool has nests identified by color-coded arrows (Figure 4-49).

4.13.2.1.5 The Military Standard tool MS 25020 (Figure 4-50) has an indenter for aluminum that is shaped differently from the indenter used for copper.

TO 00-25-234

4.13.2.2 **Power Tools.** Power crimping tools (Figure 4-51) operate on air pressure. Power trigger must be depressed until crimp is complete. Power tools use specific inserts, called heads, dies, die sets or press dies, for each terminal lug being crimped.

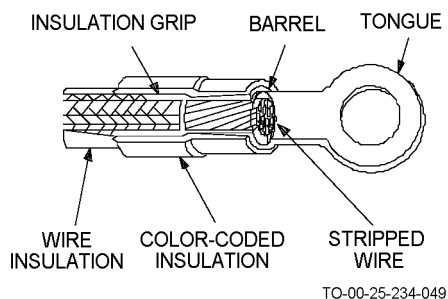

TO-00-25-234-049

Figure 4-46. Pre-Insulated Terminal Lug Cutaway

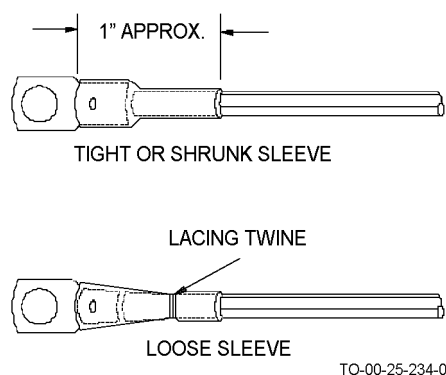

TO-00-25-234-050

Figure 4-47. Insulating Sleeves

4.13.3 **Crimping Procedure.** To crimp pre-insulated copper terminal lugs in the No. 10 to 22 wire size range:

- Strip wire insulation. (Stripping length 3/16 inch for sizes 14 through 22 and 9/32 inch for sizes 10 and 12.)
- Insert terminal lug, tongue first, into hand tool barrel crimping jaws, until terminal lug barrel butts flush against tool stop. Figure 4-52 shows correct and incorrect insertion methods.
- Squeeze tool hands slowly, until tool jaws hold terminal lug barrel firmly in place, but without denting it.
- Insert stripped wire into terminal lug barrel until wire insulation butts flush against end of barrel.
- Squeeze tool handles until ratchet releases.
- Remove completed assembly and examine it for proper crimp.

4.13.4 **Crimp Inspection.** Examine the crimped connection for the following:

- Indent centered on terminal lug barrel.
- Indent in line with barrel, not cocked.
- Terminal lug barrel not cracked.
- Terminal lug insulation not cracked.
- Insulation grip crimped.

4.14 WIRE WRAPPED ELECTRICAL CONNECTIONS.

Wire wrapped connections are coils of wire on special terminals and, properly applied, provide highly reliable electrical connections.

4.14.1 **Use.** Wire wrapped connections are formed by hand or by a power tool. In either case, use nickel-plated, solid copper wire, AWG sizes No. 20, 22, 24, or 26, insulated with nylon jacketed, polyvinyl chloride. Remove insulation with approved stripper to prevent conductor damage. Remove sufficient insulation to allow 5 wraps of AWG No. 20 and No. 22 or 6 wraps of AWG No. 24 and No. 26 around the wrapping post. Apply the first wrap as near the wire wrapping post base as practical. Figure 4-54 illustrates the proper method of applying a wire wrapped connection using a wire wrapping tool (Gardner-Denver Model 14BIAL, or equivalent). Insert stripped wire into the feed slot up to the insulation. Position wire in the anchoring notch. Place the bit on the terminal post as far as possible and wrap wire. An acceptable wire wrap must meet the following criteria:

NOTE

Wire wrapping shall only be accomplished when specified by equipment handbooks and when proper tools are authorized.

- Adjacent wires must not overlap.
- The space between individual turns must not exceed half the diameter of uninsulated wire.
- The wire end must wrap a maximum of one uninsulated wire diameter past a terminal post corner to prevent pigtailed.
- The wire must route from the terminal post such that the connection does not tend to unwrap.

4.14.2 **Procedure.** To wire wrap a lead, proceed as follows (Figure 4-53 and Figure 4-54).

- a. Remove insulation from wire to be connected to pin of connector 1 3/4 inch (1.750 inch) back from end using wire stripper.
- b. Insert stripped end of wire into the tip of the wire wrapping tool until insulation prevents further insertion. Bend wire into the slot in the tip of the wire wrapping tool (Figure 4-53).
- c. Place the tip of the wire wrapping tool over the terminal to be wrapped. Orient the tool so that the wire is facing the direction required.
- d. Depress and instantly release the trigger of the wire wrapping tool. The pressure needed and the time that the trigger must be depressed is comparable to firing a single round from a rifle.
- e. Remove the wire wrapping tool from the terminal. Observe that the wire has a minimum wrap of seven turns with the insulated part having one wrap for a satisfactory connection.

4.15 BOLTED ELECTRICAL CONNECTIONS.

Bolted electrical connections shall not depend upon wiring, terminals, lugs, etc. clamped between a metallic member and an insulating material of other than a ceramic or vitric nature. Make these connections using two metal members, such as two nuts, two washers, etc. (Figure 4-55).

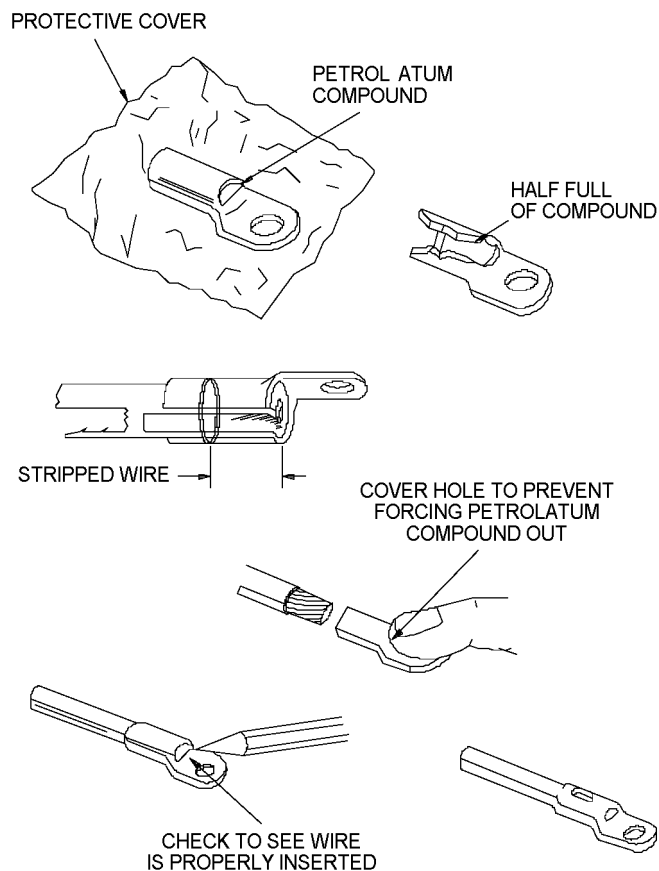

TO-00-25-234-051

Figure 4-48. Inserting Aluminum Wire Into Aluminum Terminal Lugs

4.16 INSULATING MATERIALS.

Insulating materials shall provide adequate dielectric strength and sufficient leakage resistance to assure acceptable performance of the equipments under service conditions. Impregnating materials shall not cause deterioration of the properties of the material being impregnated, either initially or after aging. Impregnating or potting compounds shall not crack at temperatures of -85°F (-65°F) and above, nor flow at temperature of $+221^{\circ}\text{F}$ ($+105^{\circ}\text{C}$) and below. Impregnating or potting compounds contained in a qualified products list shall be assumed to meet these specifications.

4.16.1 Coatings. Information on coatings is given in Chapter 6.

4.16.2 Standard Insulation Tubing. Use flexible tubing on conductors provided the tubing length is sufficiently long or fit is sufficiently tight to prevent slippage. Use only non-combustible or slow burning type flexible tubing entirely appropriate for the specific application.

TO 00-25-234

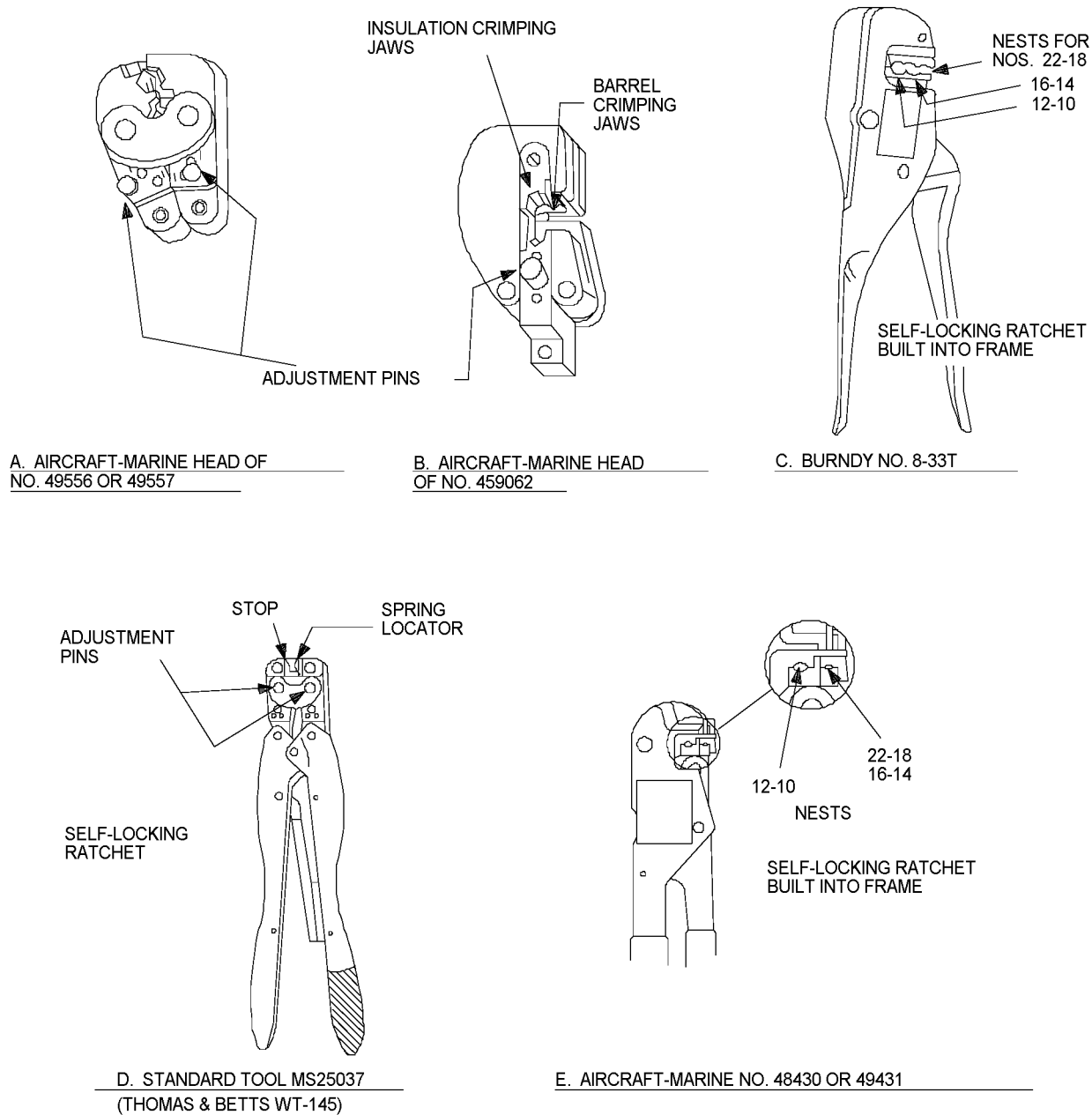

TO-00-25-234-052

Figure 4-49. Hand Crimping Tools for Pre-Insulated Terminals

4.16.3 Heat-Shrinkable Tubing. Polyethylene tubing, which is shrunk to the desired size by the application of dry heat, may be used to protect single wires or wire groups where they break out from wire bundles or harnesses. The installation procedure is as follows:

- a. Select from Table 4-6 tubing of an ID that can be slipped easily over the wire or wire group.
- b. Use a hot-air gun (Figure 4-56) as a heat source. Hold the heat source four to five inches away from the wire, and apply a heat of 275 °F to 300 °F (135 °C to 149 °C) for approximately 30 seconds. Rotate the wire while applying the heat, so that the heat is evenly distributed.

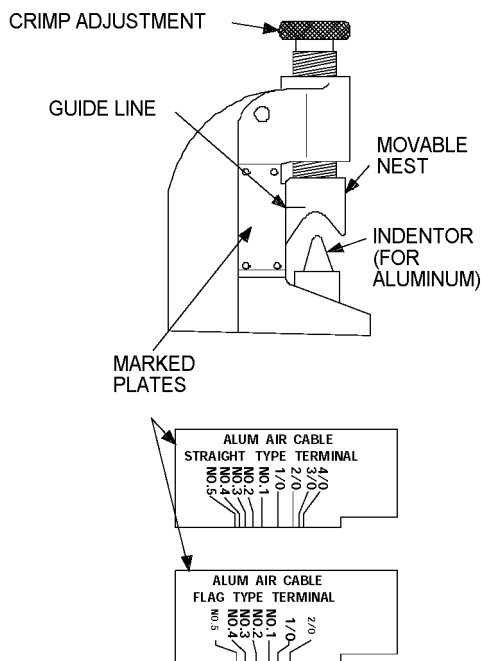

TO-00-25-234-053

Figure 4-50. Hand Crimping Tool, Aluminum Terminals

- c. Remove the heat as soon as the tubing forms to the shape of the wire, and allow to cool for approximately 30 seconds before handling.



Do not apply heat higher than 300 °F as this may damage the wire. Do not continue to apply heat after the tubing has shrunk onto the wire; further application of heat will not cause it to shrink further.

- d. If the tubing does not shrink onto the wire in approximately 30 seconds the tubing selected is probably too large. Select the next smallest size, and repeat the procedure.

4.16.4 Plastic Tape. Use only plastic tape (adhesive) or vinyl tape (non-adhesive), or silicone self bonding tape (NSN 5970-00-955-9976).

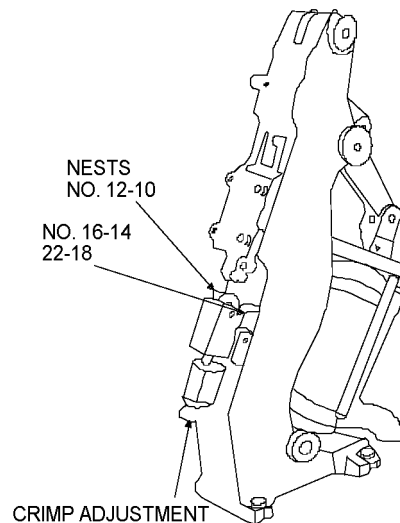

TO-00-25-234-054

Figure 4-51. Power Crimping Tools

Table 4-6. Typical Heat-Shrinkable Tubing Sizes

Sleeve Size (Thermofit)	Expanded ID (Inches) As Supplied (Minimum)	Recovered ID (Inches) After Heating (Maximum)
24	0.050	0.027
22	0.055	0.032
20	0.060	0.039
18	0.076	0.049
16	0.093	0.061
14	0.120	0.072
12	0.153	0.089
10	0.191	0.112
8	0.240	0.141
6	0.302	0.178
4	0.348	0.224
2	0.375	0.275
5/16 in.	0.413	0.334
3/8 in.	0.484	0.399
7/16 in.	0.578	0.462
1/2 in.	0.671	0.524
5/8 in.	0.843	0.655
3/4 in.	1.000	0.786
7/8 in.	1.187	0.911
1 in.	1.335	1.036
1-1/4 in.	1.670	1.290
1-1/2 in.	2.000	1.550
1-3/4 in.	2.335	1.812
2 in.	2.670	2.070

TO 00-25-234

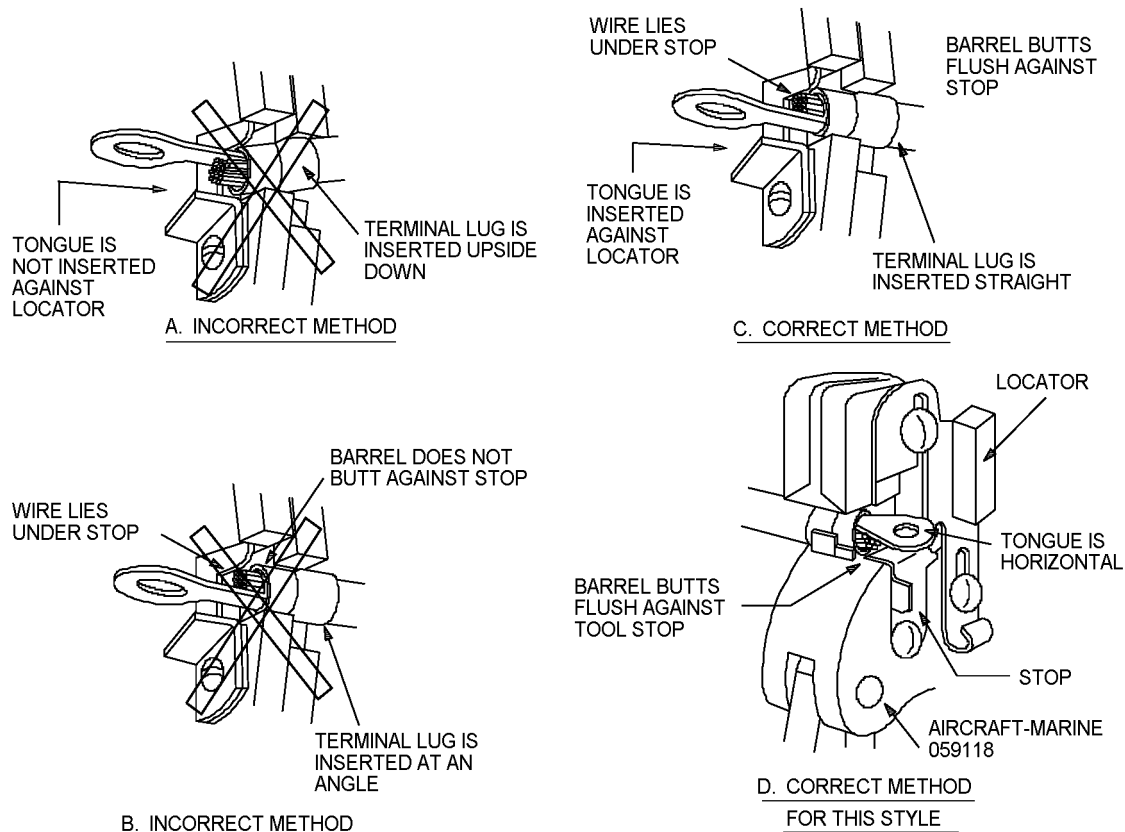

TO-00-25-234-055

Figure 4-52. Inserting Terminal Lug Into Hand Tool

4.17 POTTING OF CONNECTORS.

Potting is not only useful as an electrical insulator to hold small parts (such as resistors and capacitors) in place. Amphenol potting connectors are supplied with a plastic potting mold or with a reusable split type metallic mold. Installation is as follows:

NOTE

Teflon coated wire must be etched in accordance with TO 1-1A-14 prior to potting to assure proper adhesion.

- a. Slide the plastic potting mold over the wire bundle if this type of mold is to be used. The split reusable mold need not be placed on the wire bundle beforehand.

CAUTION

Do not install insulating sleeves over individual wires. Potting compound will not cure properly in contact with vinyl sleeving.

- b. Solder wires to contacts.
- c. Install spare wires on all unused pins. Use largest AN gage wire that would normally be attached to each contact. Spare wires will be approximately 9 inches long (Figure 4-57).
- d. Clean the complete connector assembly by scrapping off rosin and then brush vigorously in fresh dry cleaning solvent, followed by second rinse in clean dry cleaning solvent (Figure 4-58).

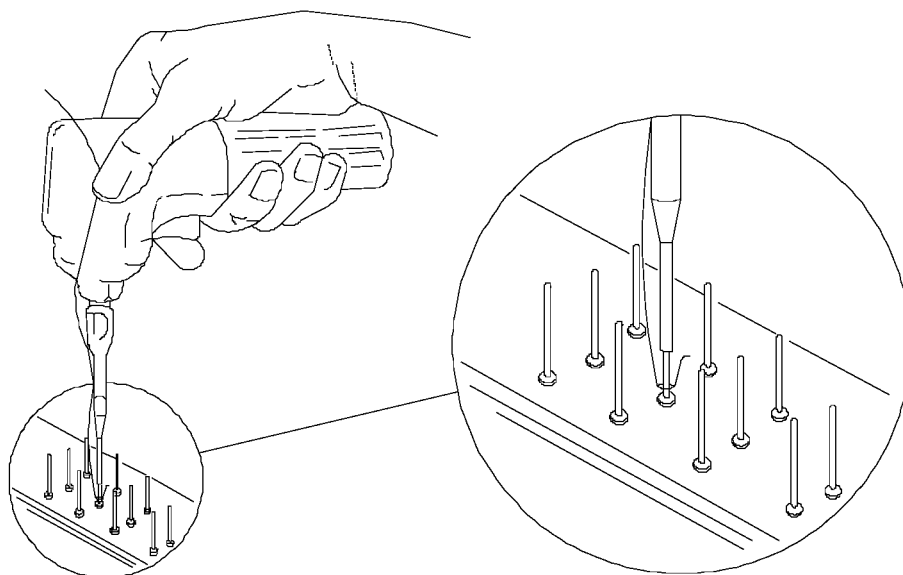

TO-00-25-234-056

Figure 4-53. Wire Wrapping Tool in Use

WARNING

Isopropyl Alcohol (TT-I-735) is toxic and flammable. Avoid eye and skin contact or breathing of vapors. Protective equipment consisting of industrial goggles and rubber gloves is required. Personnel injury could result.

- e. Rinse area to be potted with isopropyl alcohol applied from hand-operated laboratory wash bottle or similar device.

NOTE

Complete potting within two hours after cleaning.

- f. Install the reusable mold or slide plastic mold to position.

WARNING

Potting compound and accelerator are toxic to eyes, skin, and respiratory tract. Eye and skin protection required. Use only in a well ventilated area.

- g. Insert potting compound prepared in accordance with specific manufacturer's instructions. Fill back of con-

necter by inserting nozzle down between wires until it almost touches back of insert (Figure 4-59). Fill slowly while moving nozzle back from insert and watch compound to be sure no air bubbles are trapped. Fill to top of mold. Tamp down the compound, if necessary, with a wooden or metal 1/8 inch dowel. Tap connector assembly on a resilient surface or vibrate mechanically to help flow the compound into all spaces and to release trapped air.

- h. Seal the ends of all spare wires by dipping into potting compound to a depth of about 1/2 inch (Figure 4-57).
- i. Immediately after filling each connector, tie the wires together loosely about 6 inches back from connector. Be sure that wires are centrally located in the connector so that each wire is completely surrounded by potting compound. Suspend the assembly by placing the tie over a nail (Figure 4-58) and allow to air cure for at least 1 1/2 hours at +75 °F (+23.89 °C) without any movement.
- j. Carefully place assembly still suspended from nail into drying oven for 3 to 4 hours at +100 °F (+37.78 °C) or air cure at +75 °F (+23.89 °C) for 24 hours.

TO 00-25-234

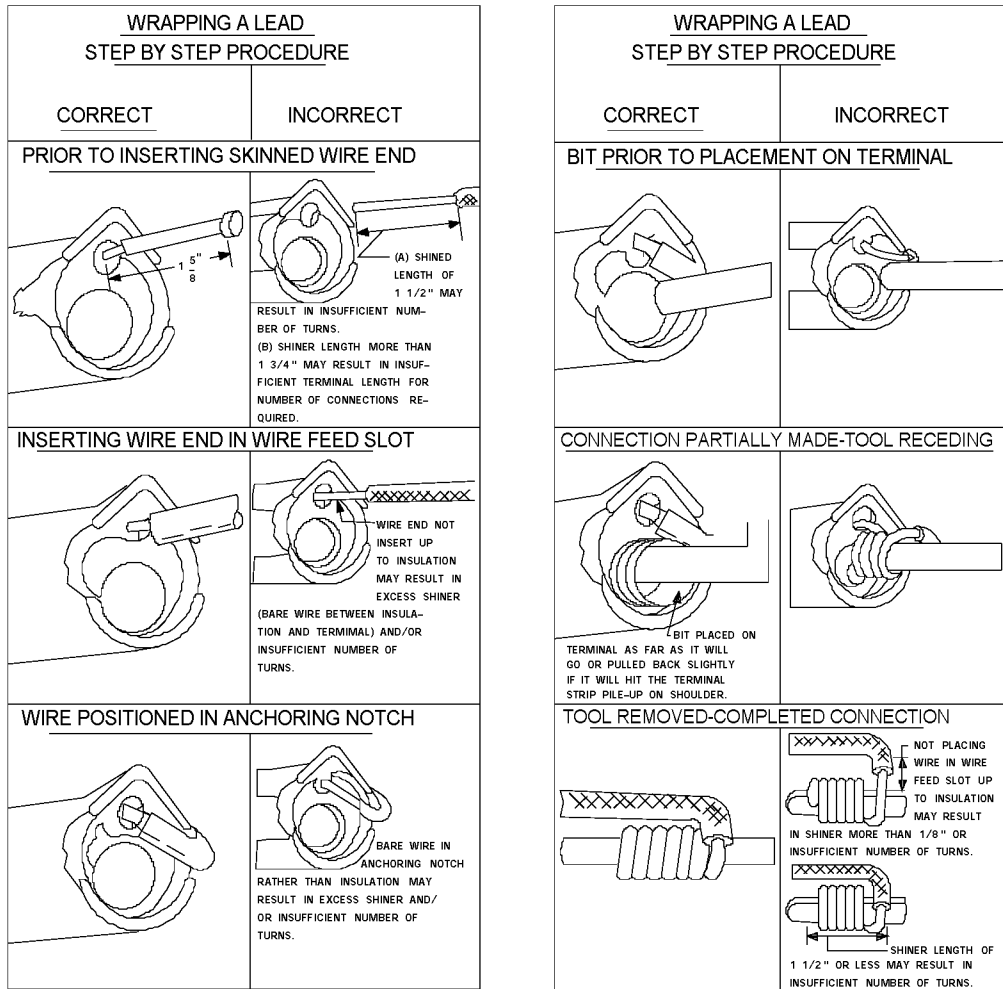

TO-00-25-234-057

Figure 4-54. Wire Wrapping Technique

NOTE

Full care with maximum electrical characteristics is not achieved until 24 hours after potting. Do not perform any electrical insulation resistance tests until this period has passed.

- k. Moisture-seal plugs by installing Military Standard O-ring MS 29513 on the barrel (Figure 4-60).

4.18 CLEANING PROCEDURES.

Electronic equipment requires general cleaning prior to final ascertainment of serviceability. Equipment shall be free of the following contamination:

Metal chips and other foreign matter.

Loose, spattered, or excess solder.

Oils and greases.

Fingerprints, grime, dust, dirt, etc.

Corrosion.

Oxidation.

- 4.18.1 Moderate Contamination. Clean moderately contaminated devices as indicated by Table 4-7.

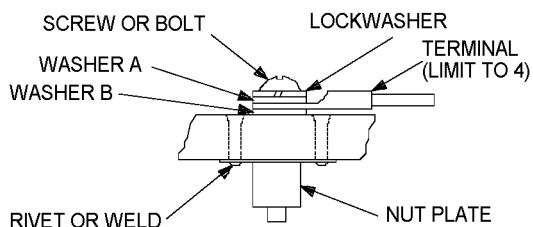
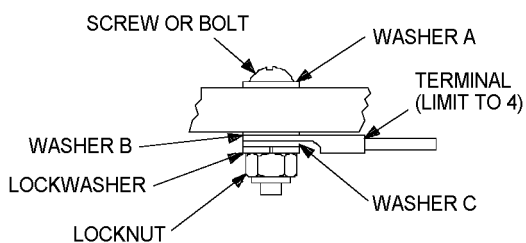
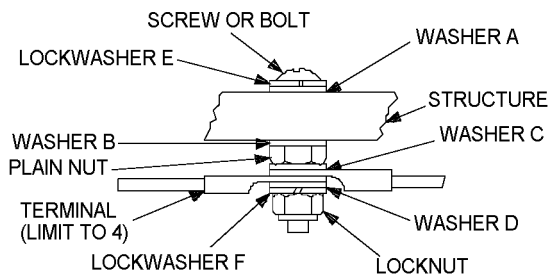

TO-00-25-234-058

Figure 4-55. Typical Bolted Connections

4.18.2 Ultrasonic Cleaning.

WARNING

- Ultrasonic cleaning may be harmful to soft tissue. Use caution when placing hands into tank.
- Ensure that the ultrasonic cleaning process has been reviewed by local Bioenvironmental Engineers and that proper procedures are followed.

Excessively contaminated devices require specialized clean-

ing techniques. MIL-C-24196 is the general specification of Ultrasonic Cleaning Systems. Every precaution should be taken to insure adequate ventilation, cleanliness, proper handling, and prevention of prolonged physical contact with the solvents.

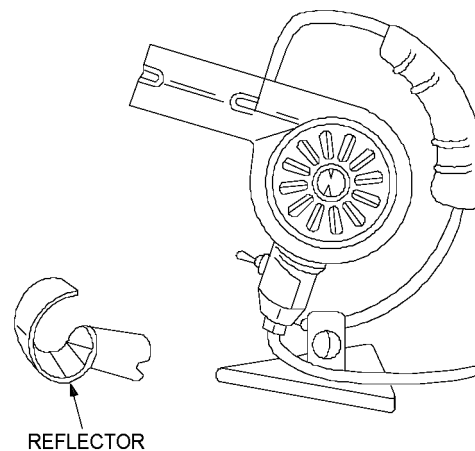

TO-00-25-234-059

Figure 4-56. Electric Hot-Air Gun

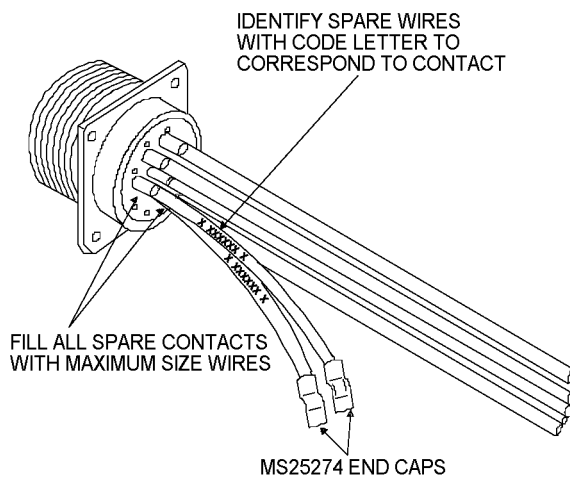

TO-00-25-234-060

Figure 4-57. Spare Wires for Potted Connector

TO 00-25-234

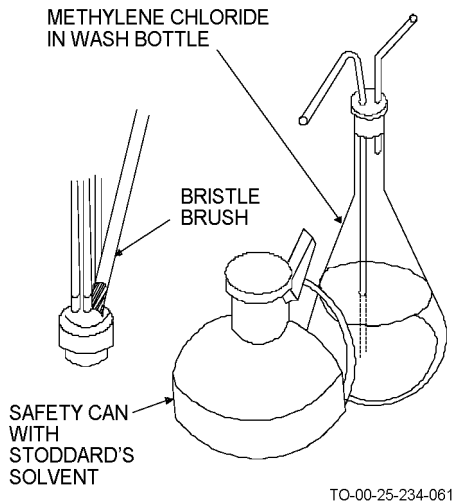

Figure 4-58. Cleaning Connector Prior to Potting

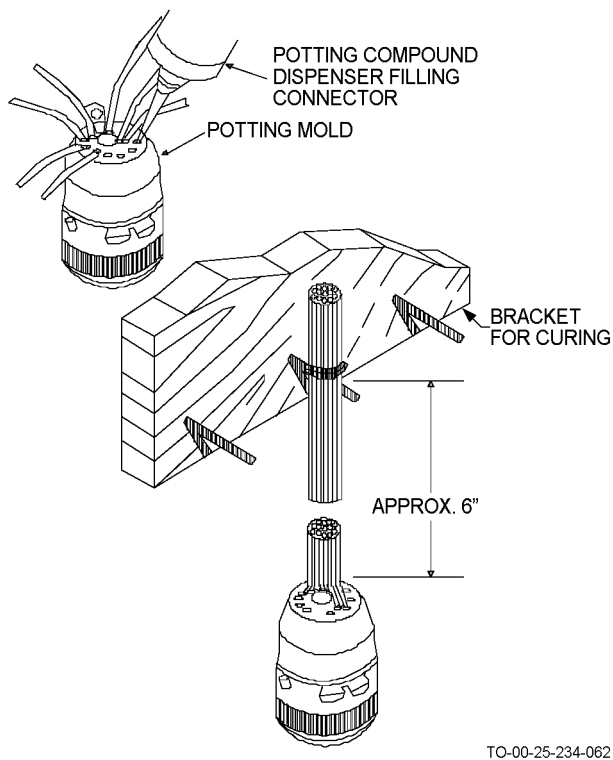

Figure 4-59. Filling and Curing Potted Connector

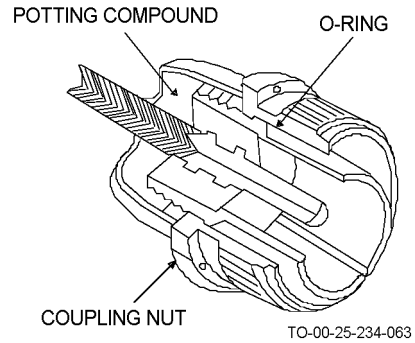

Figure 4-60. Installation of O-Ring on Potted Connector

CAUTION

- Temperature control is of extreme importance when using any solvent in an ultrasonic cleaner. Many solvents approved for cleaning of electronic equipment by conventional means are detrimental when using ultrasonic agitations. Personnel should be thoroughly familiar with the ultrasonic cleaner and associated technical manuals.
 - Do not clean equipment containing semiconductors or static sensitive components in ultrasonic cleaning systems.
- a. Ultrasonic cleaning is very efficient. It is applicable to the majority of cleaning problems encountered at depot level maintenance, and should be used whenever practical. Both solvent and water base solutions may be used. Solvents are very effective in ultrasonic applications but complete relubrication of equipment is required after cleaning.

NOTE

- Additional drying time is required for units containing RF transformers, RF coils, potentiometers, or any other parts in semisealed containers that are cleaned using a water base detergent.
- b. If a water base solution is used the approved type is MIL-C-87937. Water base solutions are especially ap-

plicable when the removal of lubrication must be controlled. Precautions must be taken to insure complete and rapid drying when using water base solution. Solvent and detergent solutions shall be maintained at the manufacturer's recommended temperature but should never exceed 130 °F (54 °C) when cleaning electronic components. Exposure time in both solvent and detergent shall be determined by type of item being cleaned.

4.18.3 Aerosol Cleaners. Aerosol cleaners may be used for removing dust, dirt, oil, grease, oxide film and similar contaminants from electrical contacts, either assembled or disassembled. These materials are supplied with a 6 in. long tube for directing the cleaner into areas of limited access.

Table 4-7. Cleaning Moderately Contaminated Devices

Type of Contamination	Cleaning Technique
Rust or other oxidation	Sand (use nonmetal abrasive) *
Loose solder, metal chips	Brush or vacuum
Oil and grease	Wipe with disposable paper toweling
Dust and dirt	Blow with compressed air of suitable pressure **
Grime and fingerprints	Wipe with clean detergent moistened cloth
* Aluminum wool may be used on aluminum surfaces of items such as: mountings, cases, covers, stripped chassis, etc provided the work is accomplished in working areas isolated from those areas in which electronic equipment is processed or stored.	
WARNING	
** Compressed air shall not be used for cleaning purposes except where reduced to less than 30 psi and then only with effective chip guarding and personnel protective equipment.	

4.18.4 Other Cleaning Techniques. The following cleaning methods may be used when required:

- a. Use vapor blasting when necessary. However, equipments containing electrical circuits, or moving parts, such as relays, bearings or motors shall not be cleaned by this method. Remove painted or plastic parts prior to vapor blasting.
- b. Use immersions, spray or electro-cleaning when adaptable and when damage to the equipment will not result.
- c. Use solvents when applicable (immersion, spray, or vapor degreasing) to achieve high quality cleaning, providing the equipment and the health and safety of personnel are not endangered.
- d. The authorized organic solvents listed in Table 4-8 dissolve or soften oily or greasy compounds, although they may not be completely interchangeable. In general, the more active solvents attack finishes, insulation, etc.

e. Other cleaning methods detailed in applicable official directives may be used.

4.18.5 Cleaning AN Connectors. Where small amounts of rust, corrosion or oxide deposits are present on AN connectors, either internally or externally, clean the connectors with a brush or aluminum wool and wash with a noncorrosive solvent. Care must be exercised to ensure that no metal fillings or residue remain inside the connector and that the connector is thoroughly dry before the male and female portions are joined. Where rust, corrosion or oxide deposits are present in large quantities, replace the AN connector.

Table 4-8. Types of Organic Solvents

Type of Solvent	Specification
Stoddard Solvent	Federal Specification P-D-680, Type III

Table 4-8. Types of Organic Solvents - Continued

Type of Solvent	Specification
Isopropyl Alcohol	Specification No. TT-I-735 , Grade A, Technical
Aliphatic Naphtha	Specification No. TT-N-95

NOTE

Use Environmental Protection Agency (EPA) nonozone depletion chemicals/solvents or local processes approved for Air Force manufacture/repair of avionics equipment.

4.18.6 Cleaning Group A and Group B Components.

Remove small amounts of rust, corrosion or oxide deposits on Group A and Group B components to the bare metal and touch up or refinish with a suitable paint or protective coating selected from the applicable qualified products list unless the portion of the metal involved is used as a ground connection. In these instances the metal must remain free of any type of protective coating. In general, use the least abrasive method possible to remove the contaminant from the affected surface and follow with a non-corrosive solvent and thorough drying prior to applying a protective coating. When using an abrasive to remove the rust, corrosion or oxide deposit, exercise care to ensure that residue does not enter any parts or components such as relays, gears, tube sockets or switches which may result in malfunction of the equipment. Clean aluminum surfaces with a cloth, brush, aluminum wool or fine sandpaper. Steel surfaces may require the use of a wire brush or emery cloth, however, wire brushes shall be used only if there is no danger of fire hazard due to sparks generated from the friction of the metals.

4.18.7 Capacitor Leakage.

- a. If capacitor electrolyte leakage is to be cleaned, first determine whether the electrolyte is acidic by placing a piece of blue litmus paper (MS36253-2, 6640-00-290-0146) in the fluid. If the leakage is dry, moisten the litmus paper in water and place it on the residue. If the paper turns red, the electrolyte is acidic and should be treated per Step b. If there is no color change, clean boards with isopropyl alcohol.
- b. Apply a solution of 20 percent sodium bicarbonate (approximately 1 oz. of sodium bicarbonate to one pint of water), specification O-S-576, to the affected area with a brush or swab. Continue to apply the solution until the bubbles cease. Wait five minutes. Rinse the surface with water, followed by a rinse of isopropyl alcohol.

4.18.8 Precious Metal Contacts. Precious metal contacts should be cleaned with aerosol cleaner using a urethane swab or lint free pad to entrap and remove all residue. Under no circumstances shall abrasive materials be used to clean precious metal contacts

4.19 CORROSION PREVENTIVE TREATMENTS.

Equipment, parts and accessories used in the overhaul of electronic equipments shall possess protective finishes resistant to corrosion, composed of nonnutrient fungicidal materials when practical.

4.19.1 Equipment Exteriors. Retouch or spot-paint equipment exteriors whenever a scratch, mark or scar penetrates to the bare metal or basic structural material of the unit. Use paint similar to that of the original coating. Completely remove paint and/or completely repaint unit only when the surfaces are so scratched or marred as to make spotting and touchup impractical.

4.19.2 Connectors. After cleaning connectors apply minimum amount of isolating compound (MIL-S-8660B G.E.) or Dow Corning 4 compound 6850-00-177-5094 or equivalent on threads and mechanical mating surfaces of connectors used in moist and salt environments. Connectors used in portable test units are coated lightly with Dow Corning 4X spray, NSN 9150-00-823-7860, or equivalent, on mechanical mating surfaces to prevent corrosion and extend connector life by easing mating and demating pressures.

4.19.3 Aluminum Alloy Parts. Anodize or apply approved chemical film to aluminum alloy parts which are not grounded or bonded. When grounding or bonding is essential, use corrosion resistant alloys 3S, 52S, 53S or equivalent.

4.19.4 Ferrous Alloys. Apply passivation treatment to corrosion resistant ferrous alloys. Further protective measures will not be necessary unless required for desirable electrical or mechanical reasons. Chromium stainless steel will not require passivation treatments provided corrosion resistance requirements are met. Do not use ordinary iron and steel unless plated in accordance with applicable specifications listed in ANA Bulletin No. 400. However, iron and

steel laminations used in magnetic circuits need not be plated or given protective finishes provided they are otherwise protected against corrosion.

4.19.5 Cadmium Plated Parts. Cadmium plated parts, plated in accordance with Specification QQ-P-416, Type II, do not need corrosion preventive treatment.

NOTE

The presence of surface film of cadmium oxide does not indicate corrosion of basic metal providing the cadmium plating is still evident under the white oxide film. However, to extend serviceability of the surface, brush off all accessible oxide deposits with a stiff brush. Apply moisture fungus-proofing finish.

4.19.6 Magnesium and Magnesium Alloys. Magnesium and magnesium alloy parts, treated in accordance with Specification MIL-M-3171 do not require further corrosion prevention treatment.

4.19.7 Zinc and Zinc Plated Parts. Zinc and zinc plated parts, given dichromate treatment in accordance with Specification QQ-A-225/8, do not require further corrosive preventive treatment.

4.20 FUNGUS PREVENTION.

Use fungistatic and fungicidal materials in accordance with procedure outlined in appropriate directives for moisture and fungus preventive treatment.

4.21 PRESSURIZATION TEST.

Pressurization of electronic equipment, when required by specific official directives, shall be tested prior to the return of units to serviceable supply stocks.

NOTE

Perform all pressure testing with equipment at room temperature.

- a. After sealing equipment, apply internal pressures of 15 psi above external ambient atmospheric pressures. Leakage shall not exceed 8 cubic inches per minute.
- b. Units must operate properly under internal pressures of no less than 5 psi above external ambient atmospheres.
- c. Detailed pressurization requirements as contained in specific applicable official directives shall take precedence over these provisions.
- d. Make sure air in the units will remain dry under storage conditions.

4.22 MARKING AND IDENTIFICATION.

Designations used for markings shall conform with IEEE-200. These markings shall not adversely affect leakage paths between conductors or any other performance factor.

- a. Provide labels showing wiring and schematic diagrams, lubricating and operating instructions, safety notices etc, when requirements exist and space permits. Use Gothic lettering. The size of labels shall correspond to content and available mounting space. When practical, make name-plates 3 inches long by 1 inch wide with 1/16-inch borders.
- b. Use the following materials and processes to fabricate labels:
 - (1) Reverse-etch aluminum plate.
 - (2) Metal photo process.
 - (3) Print on good grade white bond paper, laminate between two sheets of clear transparent vinyl resin, and bond together to seal out moisture.
 - (4) Lithograph or print on suitable paper.
 - (5) Etch on suitable plate filled with permanent contrasting color paint.
 - (6) Scotchcal process.
 - (7) Silk screen.
 - (8) Non-water-soluble decalcomanias.
 - (9) Paint on Graphic Lamicord (MICA Insulator New York) or equivalent.
 - (10) Rubber stamp with waterproof ink.
- c. Mark panels adjacent to the item to be identified with a single word, phrase, or abbreviation indicating the use or purpose of the item. Mark panels legibly and in a contrasting color.
- d. Identify removable plugs by "P" numbers corresponding to "J" numbers of mating receptacles, unless specific directives state otherwise.
- e. Reference symbol designations shall coincide with symbol designations contained in official drawings, diagrams and/or directives. Missing reference symbols will not require replacement unless needed for the operation and maintenance of the equipment.

TO 00-25-234

- f. To avoid erroneous interpretation of numerals 6 and 9 on rotating card type indicators, paint a stripe 1/32-inch x 3/32-inch under the numerals 6 and 9 during contractual maintenance or depot level overhaul. Use paint similar to the original paint in composition, type color quality and thickness, as described in indicated Military Specifications.
- g. Mark tube socket identification on the tube side of the chassis adjacent to the tube socket. Designate the type and reference symbol of the tube. In the event available space does not permit such markings, attach diagram indicating the location, type, and reference symbol of the tube to a convenient location on the chassis.

4.23 TROUBLESHOOTING.

Troubleshooting is a systemic approach to identification and locating the part or parts causing a malfunction. General troubleshooting consists of:

- a. Localizing the trouble to a major functional area by:
- (1) Visually inspecting for burned, broken, loose, or missing fuses, plugs, wires, etc., and noting any evidence of damage to cabinet.
 - (2) Following normal operating procedures for equipment and noting all abnormal functions.
 - (3) Checking test points, available for observing performance of major units, and noting abnormal indications.
- b. Isolating the faulty circuit within the major functional area by:
- (1) Visually inspecting for evidence of overheated, loose, or broken parts or wires and checking relay contacts for proper operation.
 - (2) Checking test points to find the circuit where normal indications end and incorrect readings begin.
- c. Detecting faulty part within the circuit by:
- (1) Visually checking all parts of the faulty circuit for evidence of damage.
 - (2) Checking circuit and component parameters to determine faulty part or adjustments.

NOTE

Adjustable components with locknuts should have the locknuts loosened before attempting an adjustment. Make sure that locknuts are tightened after adjustments are completed and that alignments are not disturbed.

- d. Refer to TO 00-25-259 for printed circuit board troubleshooting.

4.24 REPLACEMENT AND REPAIR OF PARTS.

Defective electronic parts such as fuses, lamps, resistors, capacitors, inductors, transformers, relays, meters, semiconductors, and electron tubes are generally replaced rather than repaired. Substitution parts are used only when necessary. Some parts, such as power cords, controls switches, relays, and cabinets, with slight damage are repairable. In either case, the replaced or repaired part must be equivalent to original part to maintain performance, reliability and safety.

4.24.1 Fuses. Use fuses, fuse posts, and fuse holders of approved type in accordance with qualified products lists, applicable technical orders and specifications, or other official directives.

- a. Replace corroded or oxidized fuses regardless of other conditions.

WARNING

- Inspect the construction of slow-blow fuses rated 0.3 AMP and below. Fuses (0.3 AMP and below) found to be of the resistor-spring-wire construction as indicated in Figure 4-61 present a potential safety hazard if they are exposed (mounted in fuse blocks or clips). These fuses have been found to overheat or explode when subjected to certain overloads. When these fuses are encapsulated in a fuse holder, there is no longer a safety hazard.
 - No such failures have been experienced with similar resistor-spring-wire fuses rated above 0.3 AMP.
 - No such failures have been experienced with 313 series spiral wire construction fuses or similar fuses rated below 0.3 AMP.
- b. To avoid a potential safety hazard, all resistor-spring-wire construction 313 series slow blow fuses (reference Figure 4-61) rated below 0.3 AMP that are exposed (mounted in fuse blocks or clips) should be replaced with the appropriate military F02 fuse listed below, or the appropriate 313 series fuse that utilizes spiral wire construction.

Commercial Item	Military Replacement Fuse
313.010	F02B250V 1/100A
313.031	F02B250V 1/32A
313.040	F02B250V 1/25A
313.062	F02B250V 1/16A

Commercial Item	Military Replacement Fuse
313.100	F02B250V 1/10A
313.125	F02B250V 1/8A
313.150	F02B250V 15/100A
313.175	F02B250V 175/1000A
313.187	F02B250V 3/16A
313.200	F02B250V 2/10A
313.250	F02B250V 1/4A
313.300	F02B250V 3/10A

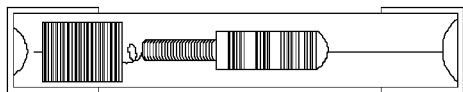

TO-00-25-234-064

Figure 4-61. Slow-Blow Fuse

Cartridge fuses F02 and F03 are 1 1/4 inches long and 1/4 inch diameter in fuses F05 and F06 are 1 1/4 inches long and 9/32 inch in diameter. Do not interchange the two sizes.

(1) Verify technical application of substitute fuses prior to use in all circuits as follows:

(a) The physical size of fuse satisfies requirements.

- (b) The current rating of the substitute does not exceed rating of original fuse.
- (c) For explanation of markings used on fuses. Table 4-8 provides cross-references for different types of fuses.
- (d) Military fuses designations. Military fuse designations differ from commercial fuse designations and are divided into four parts as follows. Figure 4-58 provides information to decode old and new military fuses designations.

Style.

Blowtime characteristics.

Voltage rating.

Current rating.

- (e) The voltage rating of the substitute fuse must equal or exceed voltage rating of original fuse.
- (f) Blow time characteristics are extremely important. Fast blow fuses should only be replaced by fast blow fuses. Temporary substitution of fast blow fuses for slow blow fuses is allowed.

Table 4-9. Cross Reference, Military and Commercial Fuses

Military, Old	Military, New	Commercial (Buss)	Commercial (Littlefuse)
F02GR010A ¹	F02A 250V 1/100A	AGC 1/100	312 3AG 1/100A 250V
F02GR031A	F02A 250V 1/32A	AGC 1/32	312 3AG 1/32A 250V
F02GR062A	F02A 250V 1/16A	AGC 1/16	312 3AG 1/16A 250V
F02GR125A	F02A 250V 1/8A	AGC 1/8	312 3AG 1/8A 250V
F02GR250A	F02A 250V 1/4A	AGC 1/4	312 3AG 1/4A 250V
F02GR375A	F02A 250V 3/8A	AGC 3/8	312 3AG 1/8A 250V
F02GR500A	F02A 250V 1/2A	AGC 1/2	312 3AG 1/2A 250V
F02GR750A	F02A 250V 3/4A	AGC 3/4	312 3AG 3/4A 250V
F02G1R00A	F02A 250V 1/A	AGC 1	312 3AG 1/A 250V
F02G1R50A	F02A 250V 11/2A	AGC 1 1/2	312 3AG 11/2A 250V
F02G2R00A	F02A 250V 2A	AGC 2	312 3AG 2A 250V
F02G3R00A	F02A 250V 3A	AGC 3	312 3AG 3A 250V
F02G4R00A	F02A 250V 4A	MTH 4	312 3AG 4A 250V
F02G5R00A	F02A 250V 5A	MTH 5	312 3AG 5A 250V
F02G6R00A	F02A 250V 6A	MTH 6	312 3AG 6A 250V
F02GR010B	F02B 250V 1/100A	MDL 1/100	313AG 1/100A 250V
F02GR031B	F02B 250V 1/32A	MDL 1/32	313AG 1/32A 250V
F02GR062B	F02B 250V 1/16A	MDL 1/16	313AG 1/16A 250V

Table 4-9. Cross Reference, Military and Commercial Fuses - Continued

Military, Old	Military, New	Commercial (Buss)	Commercial (Littlefuse)
F02GR125B	F02B 250V 1/8A	MDL 1/8	313AG 1/8A 250V
F02GR250B	F02B 250V 1/4A	MDL 1/4	313AG 1/4A 250V
F02GR375B	F02B 250V 3/8A	MDL 3/8	313AG 3/8A 250V
F02GR500B	F02B 250V 1/2A	MDL 1/2	313AG 1/2A 250V
F02GR750B	F02B 250V 3/4A	MDL 3/4	313AG 3/4A 250V
F02G1R00B	F02B 250V 1A	MDL 1	313AG/A 250V
F02D1R50B	F02B 125V 11/2A	MDL 11/2	313 AG 11/2A 125V
F02D2R00B	F02B 250 2A	MDL 2	313 AG 2A 125V
F02D3R00B	F02B 125V 3A	MDX 3	313 AG 3A 125V
F03G1R00A ¹	F03A 250V 1A	ABC MB0 1	314 3AB 1A 250V
F03G3R00A	F03A 250V 3A	ABC or MB0 3	314 3AB 3A 250V
F03G3R00A	F03A 250V 5A	ABC or MB0 5	314 3AB 5A 250V
F03G8R00A	F03A 250V 8A	ABC or MB0 8	314 3AB 8A 250V
F03G10R0A	F03A 250V 10A	ABC or MB0 10	314 3AB 10A 250V
F03G12R0A	F03A 250V 12A	ABC or MB0 12	314 3AB 12A 250V
F03G15R0A	F03A 250V 15A	ABC or MB0 15	314 3AB 15A 250V
F03D20R0A	F03A 125V 20A	ABC or MB0 20	314 3AB 20A 250V
F03D30R0A	F03A 125V 30A	ABC or MB0 30	314 3AB 30A 250V
F03GR010B	F03A 250V 1/100A	MDA or MDF 1/100	
F03GR031B	F03B 250V 1/32A	MDA or MDF 1/32	
F03GR062B	F03B 250V 1/16A	MDA or MDF 1/16	
F03GR125B	F03B 250V 1/8A	MDA or MDF 1/8	
F03GR150B	F03B 250V 15/100A	MDA or MDF 15/100	
F03GR187B	F03B 250 3/16A	MDA or MDF 3/16	
F03GR250B	F03B 250V 1/4A	MDA or MDF 1/4	
F03GR375B	F03B 250V 3/8A	MDA or MDF 3/8	
F03GR500B	F03B 250V 1/2A	MDA or MDF 1/2	
F03GR750B	F03B 250V 3/4A	MDA or MDF 3/4	
F03G1R00B	F03B 250V 1A	MDA or MDF 1	
F03G3R00B	F03B 250V 3A	MDA or MDF 3	
F03G5R00B	F03B 250V 5A	MDA or MDF 5	
F03G8R00B	NONE	MDA or MDF 8	
F03G10R0B	NONE	MDA or MDF 10	
F03G12R0B	NONE	MDA or MDF 12	
F03G15R0B	NONE	MDA or MDF 15	
F03G20R0B	NONE	MDA or MDF 20	
F03G30R0B	NONE	MDA or MDF 30	
F04A5R00A	NONE	MTH or AGC 5	312 3AG 5A 250V
F04A10R0A	F02A 32V 10A	AGC 10	311 3AG 10A 32V
F04A15R0A	F02A 32V 15A	AGC 15	311 3AG 15A 32V
F04A20R0A	F02A 32V 20A	AGC 20	311 3AG 20A 32V
F04A5R00B	F02A 32V 5A	MDL 5	313 3AG 5A 125V
F04A10R0B	F02A 32V 10A	MDL 10	313 3AG 10A 32V
F04A15R0B	F02A 32V 15A	MDL 15	313 3AG 15A 32V
F04A20R0B	F02A 32V 20A	MDL 20	313 3AG 20A 32V
F05A10R0A	F02A 32V 10A	AGS 10	411 4AG 10A 32V
F05A15R0A	F02A 32V 15A	AGS 15	411 4AG 15A 32V
F05A20R0A	F02A 32V 20A	AGS 20	411 4AG 20A 32V
F05A25R0A	F02A 32V 25A	AGS 25	411 4AG 25A 32V

Table 4-9. Cross Reference, Military and Commercial Fuses - Continued

Military, Old	Military, New	Commercial (Buss)	Commercial (Littlefuse)
F05A30R0A	F02A 32V 30A	AGS 30	411 4AG 30A 32V
F05A35R0A	NONE	AGS 35	411 4AG 35A 32V
F05A40R0A	NONE	AGS 40	411 4AG 40A 32V
F05A10R0B	F05B 32V 10A	MDM 10	413 4AG 10A 32V
F05A15R0B	F05B 32V 15A	MDM 15	413 4AG 15A 32V
F05A20R0B	F05B 32V 20A	MDM 20	413 4AG 20A 32V
F05A25R0B	F05B 32V 25A	MDM 25	413 4AG 25A 32V
F05A30R0B	F05B 32V 30A	MDM 30	413 4AG 30A 32V
F05A35R0B	NONE	MDM 35	
F05A40R0B	NONE	MDM 40	
F06G1R00A	F06A 250V 1A	ABS 1	414 4AB 1A 250V
F06G2R00A	F06A 250V 2A	ABS 2	414 4AB 2A 250V
F06G3R00A	F06A 250V 3A	ABS 3	414 4AB 3A 250V
F06G5R00A ¹	F06A 250V 5A	**ABS 5	414 4AB 5A 250V
F06G10R0A	F06A 250V 10A	**ABS 10	414 4AB 10A 250V
F06G15R0A	F06A 250V 15A	**ABS 15	414 4AB 15A 250V
F07A5R00A	F07A 32V 5A	AGU 5	511 5AG 5A 32V
F07A10R0A	F07A 32V 10A	AGU 10	511 5AG 10A 32V
F07A15R0A	F07A 32V 15A	AGU 15	511 5AG 15A 32V
F07A20R0A	F07A 32V 20A	AGU 20	511 5AG 20A 32V
F07A30R0A	F07A 32V 30A	AGU 30	511 5AG 30A 32V
F07A35R0A	NONE	AGU 35	511 5AG 35A 32V
F07A40R0A	NONE	AGU 40	511 5AG 40A 32V
F07A50R0A	NONE	AGU 50	511 5AG 50A 32V
F07A60R0A	NONE	AGU 60	511 5AG 60A 32V
NONE	F07B 125V 1A	MDR 1	
NONE	F07B 125V 2A	MDR 2	
F07A5R00B	F07B 32V 5A	MDR 5	513 5AG 5A 125V
F07A10R0B	F07B 32V 10A	MDR 10	513 5AG 10A 32V
F07A15R0B	F07B 32V 15A	MDR 15	513 5AG 15A 32V
F07A20R0B	F07B 32V 20A	MDR 20	513 5AG 20A 32V
F07A30R0B	F07B 32V 30A	MDR 30	513 5AG 30A 32V
F07A35R0B	NONE	MDR 35	
F07A40R0B	NONE	MDR 40	
F07A50R0B	NONE	MDR 50	
F07A60R0B	NONE	MDR 60	
F08G1R00A	F07A 250V 1A	AGU 1	512 5AG 1A 250V
F08G2R00A	F07A 250V 2A	AGU 2	512 5AG 2A 250V
F08G3R00A	F07A 250V 3A	AGU 3	512 5AG 3A 250V
*F08D5R00A	*F09A 250V 5A	BAN or **AGU 5	
*F08D10R0A	*F09A 250V 10A	BAN or **AGU 10	
*F08D15R0A	*F09A 250V 15A	BAN or **AGU 15	
*F08D20R0A	*F09A 250V 20A	BAN or **AGU 20	
*F08D25R0A	*F09A 250V 25A	BAN or **AGU 25	
*F08D30R0A	*F09A 250V 30A	BAN or **AGU 30	
F08G1R00B	F09B 250V 1A	FNM or **MDR 1	513 5AG 1A 250V
F08G2R00B	F09B 250V 2A	FNM or **MDR 2	513 5AG 2A 250V
*F08G3R00B	*F07B 125V 3A	**MDR 3	513 5AG 3A 250V
F08G5R00B	F09B 250V 5A	FNM or **MDR 5	

TO 00-25-234

Table 4-9. Cross Reference, Military and Commercial Fuses - Continued

Military, Old	Military, New	Commercial (Buss)	Commercial (Littlefuse)
*F08D10R0B	*F09B 250V 10A	FNM or **MDR 10	
F08D15R0B	F09B 125V 15A	FNM or **MDR 15	
*F08D20R0B	*F09B 32V 20A	**FNM or **MDR 20	
*F09D25R0B	*F09B 32V 25A	**FNM or **MDR 25	
*F08D30R0B	*F09B 32V 30A	**FNM or **MDR 30	
F09GR100A	NONE	BAN 1/10	
F09GR150A	NONE	BAN 15/100	
F09GR200A	NONE	BAN 2/10	
F09GR300A	NONE	BAN 3/10	
F09GR400A	NONE	BAN 4/10	
F09GR500A	NONE	BAN 1/2	
F09GR600A	NONE	BAN 6/10	
F09GR800A	NONE	BAN 8/10	
F09G1R00A	F09A 250V 1A	BAN 1	
F09G1R12A	NONE	BAN 1 1/8	
F09G1R25A	NONE	BAN 1 1/4	
F09G1R40A	NONE	BAN 14/10	
F09G1R60A ¹	NONE	BAN 16/10	
F09G1R80A	NONE	BAN 18/10	
F09G2R00A	F09A 250V 2A	BAN 2	
F09G2R25A	NONE	BAN 2 1/4	
F09G2R50A	NONE	BAN 2 1/2	
F09G2R80A	NONE	BAN 2 8/10	
F09G3R00A	F09A 250V 3A	BAN 3	
F09G3R20A	NONE	BAN 3 2/10	
F09G3R50A	F09A 250V 3 1/2A	BAN 3 1/2	
F09G4R00A	NONE	BAN 4	
F09G4R50A	NONE	BAN 4 1/2	
F09G5R00A	F09A 150V 5A	BAN 5	
F09G5R60A	NONE	BAN 5 6/10	
F09G6R00A	F09A 250V 6A	BAN 6	
F09G6R25A	F09A 250V 6 1/4A	BAN 6 1/4	
F09G7R00A	F09A 250V 7A	BAN 7	
F09G8R00A	F09A 250V 8A	BAN 8	
F09G9R00A	NONE	BAN 9	
F09G10R0A	F09A 250V 10A	BAN 10	
F09G15R0A	F09A 250V 15A	BAN 15	
F09G20R0A	F09A 250A 20A	BAN 20	
F09G25R0A	F09A 250V 25A	BAN 25	
F09G30R0A	F09A 250V 30A	BAN 30	
F09GR100B	F09B 250V 1/10A	FNM 1/10	
F09GR150B	F09B 250V 15/100A	FNM 15/100	
F09GR200B	F09B 250V 2/10A	FNM 2/10	
F09GR300B	F09B 250V 3/10A	FNM 3/10	
F09GR400B	F09B 250V 4/10A	FNM 4/10	
F09GR500B	F09B 250V 1/2A	FNM 1/2	
F09GR600B	F09B 250V 6/10A	FNM 6/10	
F09GR800B	F09B 250V 8/10A	FNM 8/10	
F09G1R00B	F09B 150V 1A	FNM 1	

Table 4-9. Cross Reference, Military and Commercial Fuses - Continued

Military, Old	Military, New	Commercial (Buss)	Commercial (Littlefuse)
F09G1R12B	NONE	FNM 1 1/8	
F09G1R25B	F09B 250V 1 1/4A	FNM 1 1/4	
F09G1R40B	NONE	FNM 14/10	
F09G1R60B	F09B 250V 1 6/10A	FNM 16/10	
F09G1R80B	NONE	FNM 18/10	
F09G2R00B	F09B 250V 2A	FNM 2	
F09G2R25B	NONE	FNM 2 1/4	
F09G2R50B	F09B 250V 2 1/2A	FNM 2 1/2	
F09G2R80B	NONE	FNM 2 8/10	
F09G3R00B	NONE	FNM 3	
F09G3R20B	F09B 250V 3 2/10A	FNM 3 2/10	
F09G3R50B	NONE	FNM 3 1/2	
F09G4R00B	F09B 250V 4A	FNM 4	
F09G4R50B	NONE	FNM 4 1/2	
F09G5R00B	F09B 250V 5A	FNM 5	
F09G5R60B	NONE	FNM 5 6/10	
F09G6R00B	NONE	FNM 6	
F09G6R25B	F09B 250V 6 1/4A	FNM 6 1/4	
F09G7R00B	NONE	FNM 7	
F09G8R00B	F09B 250V 8A	FNM 8	
F09G9R00B	NONE	FNM 9	
F09D10R0B ¹	*F09B 250V 10A	FNM 10	
F09D15R0B	F09B 125V 15A	FNM 15	
F09D20R0B	*F09B 32V 20A	**FNM 20	
F09D25R0B	*F09B 32V 25A	**FNM 25	
F09D30R0B	*F09B 32V 30A	**FNM 30	
F10G1R00A	F10A 250V 1A	MIN 1	
F10G2R00A	F10A 250V 2A	MIN 2	
F10G3R00A	F10A 250V 3A	MIN 3	
F10G4R00A	F10A 250V 4A	MIN 4	
F10G5R00A	F10A 250V 5A	MIN 5	
F10G6R00A	F10A 250V 6A	MIN 6	
F10G8R00A	F10A 250V 8A	MIN 8	
F10G10R0A	F10A 250V 10A	MIN 10	
F10G12R0A	F10A 250V 12A	MIN 12	
F10D15R0A	F10A 125V 15A	MIN 15	
F10D20R0A	F10A 125V 20A	MIN 20	

¹ A letter 'S' following the PN signifies silver plating.

* Indicates voltage change from old to new military replacement.

** Indicates a commercial fuse with a lower voltage rating than one or both military fuse replacements.

(2) Commercial fuse designations. Designations of various commercial fuses differ according to the manufacturer. However, when decoded, most of

those designations provide the same general information, such as fuse type, current rating, voltage rating, and catalog number (Figure 4-62).

TO 00-25-234

NOTE

Ensure spare fuse rating is the same as active fuse.

4.24.2 Fuse Holders.**WARNING**

When installing or removing fuses which are retained in fuse cap holders, ensure the fuse cap holder will securely retain the fuse. Death or injury to personnel and damage to equipment may occur if this condition is not met.

Use fuse post or fuse holders designed for a specific type of fuse to house or hold that specific type only, unless written authorization for deviation is obtained from the AF activity with prime responsibility for the equipment involved.

4.24.2.1 Panel mounted fuse holders of the extractor-post type will be finger-operated under general service conditions. The fuse holder cap must retain the fuse when either removing or installing a fuse. Fuse holder caps in non-compliance must be discarded.

4.24.2.2 Correctly wired holders for branch-line fuses must protect against shock when changing fuses. The terminal connected to the voltage source should be inaccessible to body contact. Figure 4-63 illustrates the correct method of wiring the instrument-type non-indicator light fuse holder to prevent accidental contact with live terminal.

CAUTION

Indicator light ferrule type fuse holders DO NOT have the shock protection feature that the non-indicator ferrule type fuse holders have.

4.24.2.3 Spare fuses should be kept in an accessible location.

4.24.2.4 Substitution fuse post and fuse holders shall not violate the design characteristics of the end item of equipment.

4.24.2.4.1 Mount fuse holders in a convenient location on the front panel or at the rear of the equipment. If practical, removal and replacement of fuses will not require the removal of the unit from its case.

4.24.2.4.2 Provide protective covers to diminish danger of electrical shocks or burns.

4.24.2.4.3 Upon special authorization, and if equipment is not connected to a direct ground, use fused line cords or

appropriately fused plugs when other types of fuse holders are impractical.

4.24.2.5 Fuse holders shall be free of corrosion and cracks.

- a. Screw type fuse holders shall be tightened to a snug fit.
- b. Fuse holders shall be sufficiently tight to insure electrical contact.

4.24.3 Lamps. Use lamps of the approved type in accordance with qualified products lists, applicable technical orders and specifications, or other official directives. Replace indicator lamps that have corroded, loose, deformed, or cracked bases. Lamps should be free of black condensed filament residue.

4.24.4 Resistors. Use resistors of the approved type in accordance with applicable qualified products list, applicable technical orders and specifications, or other official directives.

- a. Replace resistors that are cracked, broken, or that have loose or broken leads.
- b. Fixed elements of variable resistors will be secure. Movable elements shall travel within prescribed limits.
- c. Glyptal shall be used to secure variable resistors after adjustments.

4.24.5 Capacitors. Use capacitors of approved type in accordance with qualified products lists, applicable technical orders, and specifications, or other official directives.

- a. Replace capacitors that show fungus, corrosion, cracks, crevices, or broken or soft spots.
- b. Replace leaking oil-filled capacitors.
- c. Replace variable capacitors that have irreparably warped or shorted plates.
- d. Keep variable capacitors clean.
- e. Replace electrolytic capacitors that are less than 90 or more than 250 percent of rated capacitance when measured with a polarized bridge operating at 120 Hz.

4.24.6 Inductors and Transformers. Use inductors approved type in accordance with qualified products lists, applicable technical orders and specifications, or other official directives.

- a. Replace inductors that are cracked, or broken, or that have loose or broken leads.
- b. Secure tuning slugs in RF and Intermediate Frequency (IF) coil forms by cement, glyptal or mechanical locking device.
- a. Replace meter when damage prevents reading monitored quantity to require accuracy.
- b. Securely bond meter to panel and employ conductive coating where necessary noise suppression requirements.

NOTE

Release tuning slug from cement with solvents or a soldering iron. Extreme caution is necessary to prevent damaging slotted end of tuning slug during alignment. Use adjusting tools available for adjustment of slugs.

- c. Use direct replacement parts in critical circuits. Use substitute parts in non-critical circuits in times of critical supply shortages, providing that inductance, current rating, dimensional requirements, etc re-suitable for replacement purposes. Installation of a substitute must not require any change structural configuration of equipment involved. Substitutions for RF with more allowable variation than could be tolerated in inductances used as video plate loads, etc.
- d. Impregnate multilayer windings with suitable material (Paragraph 4.16).
- c. Use direct replacement meters. Use substitute meters in times of supply shortage, provided physical and electrical specifications are compatible with intended application.

4.24.9 Electron Tubes, General. Consider electron tubes serviceable as received from supply unless specific checks or tests prior to installation are defined or required by a specific equipment technical order. Serviceable tubes as required from supply are considered to meet minimum requirements of applicable specification to which they are procured. Further testing of selection through use of a tube tester is not normally required or recommended. Review TO 00-25-251 to assure familiarity relative to handling, installation and operation of special purpose electron tubes. The following criteria shall be used to determine the acceptability of electron tubes whenever the technical order on the equipment in which the tube is used does not specify contrary requirements.

4.24.7 Relays. Use relays of approved type in accordance with qualified products lists, applicable technical orders and specifications, or other official directives.

- a. Replace relays (or relay contacts, if normally separable) when contacts become pitted, discolored, or burned beyond correction by burnishing, or if contact curvature becomes distorted.
- b. Relays energized from primary power sources shall be capable of pulling in firm and positive contact when reference voltage of power supply is reduced to 68 percent, and of dropping out when reference voltage is required to 50 percent, unless specific official directives state otherwise.
- c. Contact spring pressure and contact gap shall be consistent with surface area and power rating of relay.

4.24.9.1 Tubes in which the base is an integral part of the vacuum envelope must be discarded if any cracks or chips in the base are detected.

4.24.9.2 Tubes which have base (glass, plastic, metal, ceramic, etc.) glued to the envelope must be discarded if the base is cracked or is very loose. If the base is loose but can be rotated less than approximately 20 degrees, it may be recemented with an alkyd resin adhesive (Glyptal) or equivalent cement. Chipped bases shall be used unless the chip is in the guide pin or a retaining device.

4.24.8 Meters. Use meters of approved type in accordance with qualified products lists, applicable technical orders and specifications, or other directives.

4.24.9.3 Tubes which have cracked or chipped glass or ceramic envelopes shall be discarded. Tubes which have dented or cracked metal envelopes shall be discarded. Tubes which have envelopes of heavy machined metal, such as magnetrons, klystrons, etc., may be accepted with small dents in metal envelope, providing tube is serviceable in every other way.

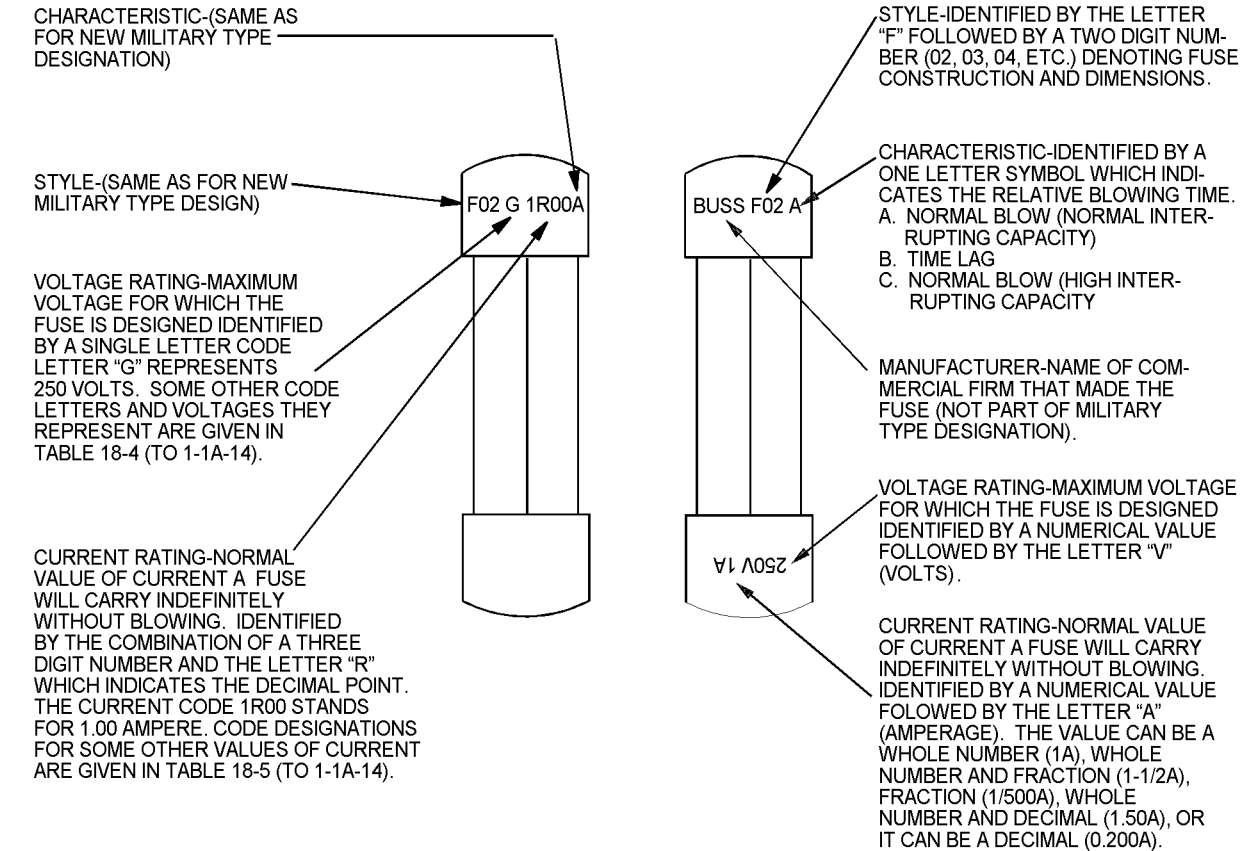

A. FUSE WITH OLD TYPE MILITARY DESIGNATIONS

B. FUSE WITH NEW MILITARY TYPE DESIGNATIONS

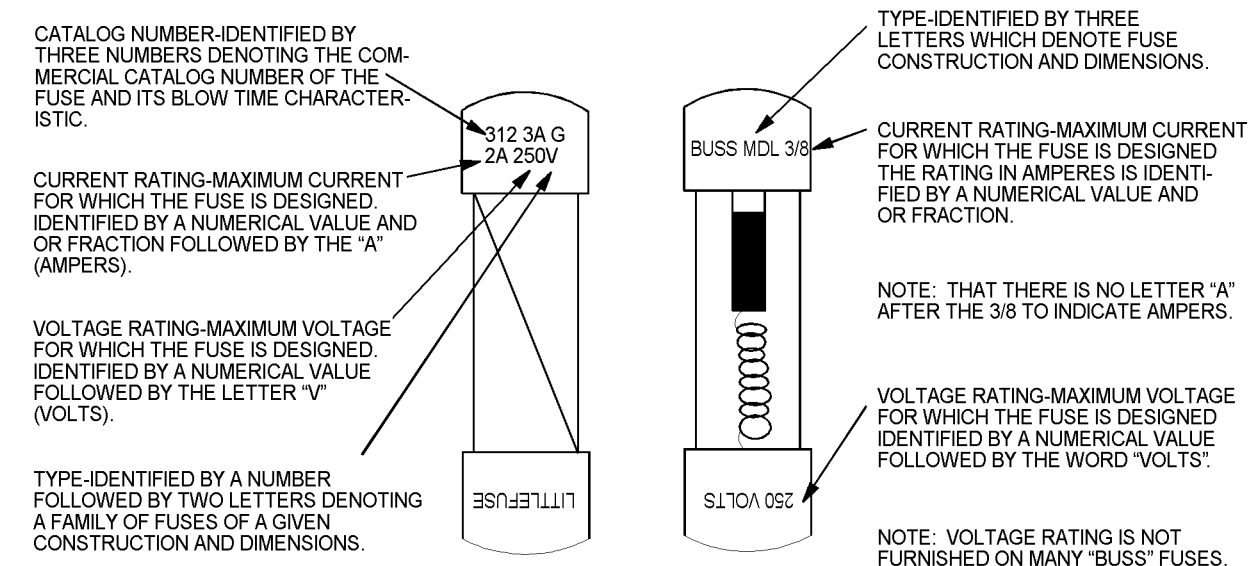

C. "LITTLEFUSE" CARTRIDGE FUSE DESIGNATIONS

D. "BUSS" CARTRIDGE FUSE DESIGNATIONS

Figure 4-62. Military Fuse Designations

4.24.9.4 Tubes which have plate or grip caps glued on must be discarded if cap is loose.

4.24.9.5 In addition to above, tubes must pass the test of an Air Force approved tube tester or a functional test in an item of equipment.

4.24.10 Cathode Ray Tubes.

WARNING

Cathode Ray Tube (CRT) is a high-vacuum tube. Implosion may occur if struck by or against another object. Face shield, apron, and gloves are required.

Special requirements for cathode ray tubes. The following tests must be performed with entire tube face illuminated to normal intensity by beam current with the beam defocused and no modulation applied to grid.

4.24.10.1 Bright spots or discolorations will not normally constitute cause for rejection.

4.24.10.2 Dead spots which exceed the limitations in Table 4-10 require that tube be discarded.

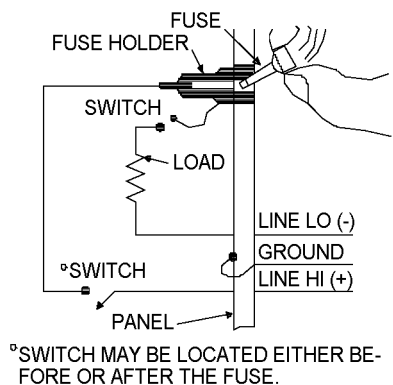

TO-00-25-234-066

Figure 4-63. Correct Wiring of Instrument-Type Fuse Holder

4.24.10.3 In addition to Table 4-10, tubes which are used as PPI may have a spot at start of the trace as follows: (The center of maximum dimension of the dead spot must be within 1/8 inch of the point on the scope face at which trace lines intersect.)

Tube Size (Inches)	Max Dim. of Dead Spot in Inches
3	3/32
5	1/8
7	3/16
9,10	3/8
12	1/2

Table 4-10. Limitations for CRT Dead Spots

Tube Size (Inches)	Max Dim of Dead Spot In Inches	Max No. of Dead Spots In Any 2-Inch Circle	Max No. of Dead Spots Per Tube	(Inches) Min Separation Between Spots
3.5	1/64 to 1/32	4	8	1/4
	1/32 to 1/16	1	2	2
	Larger than 1/16	None	None	N/A
7,9,10	1/64 to 1/32	4	40	1/2

TO 00-25-234

Table 4-10. Limitations for CRT Dead Spots - Continued

Tube Size (Inches)	Max Dim of Dead Spot In Inches	Max No. of Dead Spots In Any 2-Inch Circle	Max No. of Dead Spots Per Tube	(Inches) Min Separation Between Spots
12 and larger	1/32 to 1/16	1	9	2
	1/32 to 3/32	1	1	N/A
	Larger than 3/32	None	None	N/A
	1/64 to 1/32	4	60	1/2
	1/32 to 1/16	1	12	2
	1/16 to 3/32	1	3	2
	Larger than 3/32	None	None	N/A

NOTE

Spots less than 1/64 inch in diameter are not counted.

4.24.11 Semiconductor Devices. Semiconductor devices are serviceable as received from supply unless preinstallation tests are required by specific equipment technical or-

ders. Replacement of a lug-mounted semiconductor requires special techniques to prevent damage during installation.

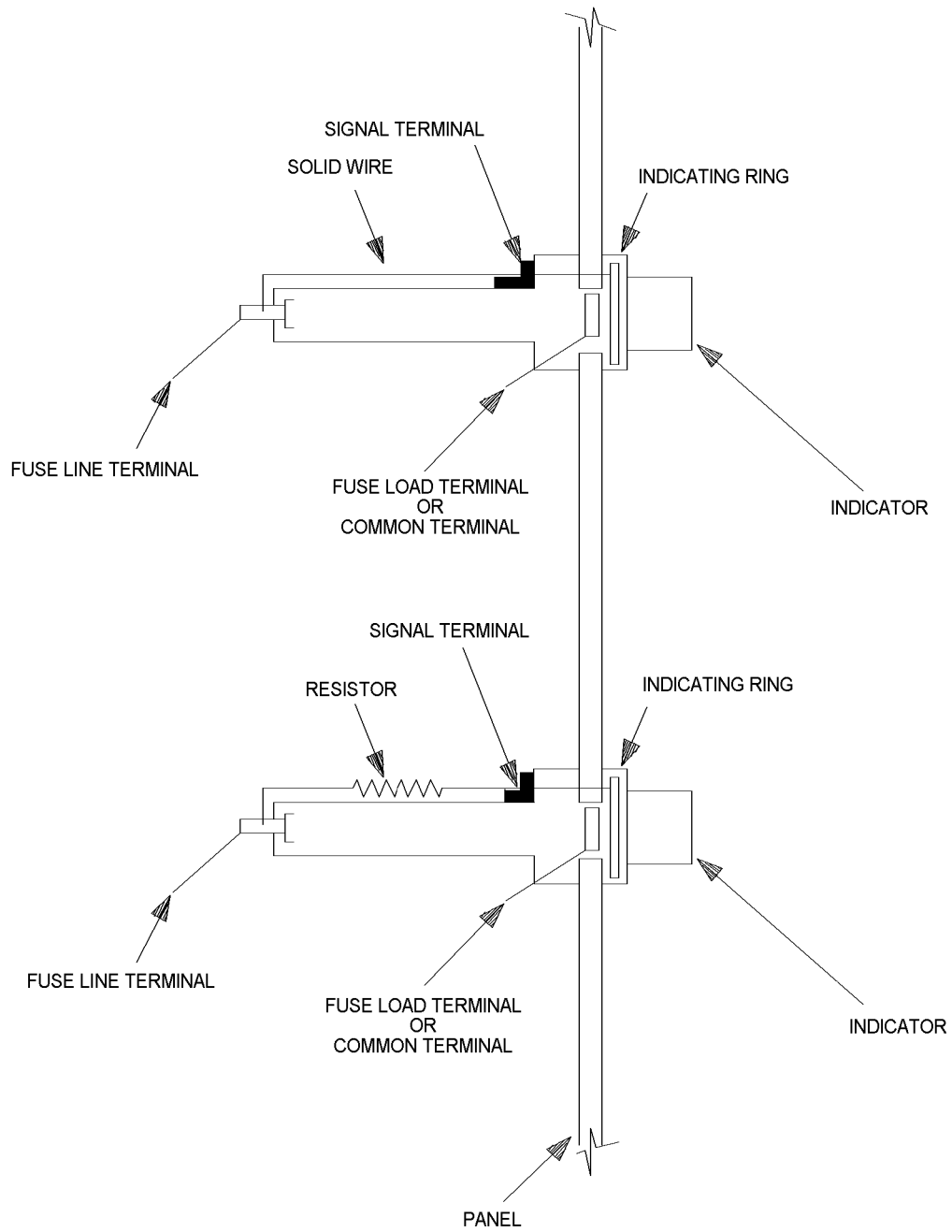

TO-00-25-234-067

Figure 4-64. Correct Wiring for Fuse Holders Containing Indicator Lights

TO 00-25-234

- a. Keep semiconductor in package until assembly.
- b. Avoid all rough handling such as dropping.
- c. Mount semiconductor on a clean, flat surface.
- d. Allow stress relief in connecting leads.
- e. Do not twist or bend semiconductor terminals. Treat rigid terminals with care to avoid cracking the hermetic seal or damaging internal connections.
- f. Consult manufacturer data to determine if a specific semiconductor can withstand shock and vibration associated with cutting, grinding, or filing mounting stud.

NOTE

Some semiconductors are available with shock ratings of 500 g at 1 millisecond along the major axis of mounting stud. Transverse shock ratings are usually less. Some semiconductors are available with environmental vibration ratings upward from 10 g at 2,000 cps; some semiconductors are available with centrifuge ratings from 5 g to 5000 g along major axis of stud.

4.24.12 MIL-C-25955 Connectors, MIL-S-24251/3 Series. Number 20 contact replacement in MIL-S-24251/3 series repairable connectors. The following procedure is to be used when replacing damaged connector contacts, or a complete connector. Special tools required for pin replacement are PN: 036052-0000 and 036069-0000.

- a. Loosen setscrews using tool 036069-0000, and slide end bell away from connector shell.
- b. Using fingers or pliers, grasp ferrule and gently pull ferrule, with grommet attached, from connector shell.



If pliers are used to extract grommet, use extreme care so that ferrule is not damaged.

- c. Use pin or socket extractor 036069-0000 and press extractor down against contact while holding shell of connector securely. Apply pressure until contact snaps out.
- d. Cut the defective contact from wire lead.
- e. Strip 5/32 + 1/32, -0 inch of insulation from wire lead. Take care not to spread or fray wire strands when stripping wire.

- f. Insert wire into contact, making certain that insulation bottoms against contact shoulder. Observe contact inspection hole and note that conductor wire can be seen.
- g. Place male contact: 036053-0000 or female contact: 036054-000 in crimping pliers 036052-0000 positioning flat side of contact toward lower jaw; then close pliers, 036057-0000.

NOTE

When wiring RG-179/U coax cable sleeve 037179-0000 must be slipped over the inner conductor before crimping to contact. Once pressure has been applied to crimping pliers, it will be necessary to completely close tool before reopening it.

- h. After required contacts (036053-0000 or 036054-0000) have been crimped to wires, install end bell and ferrule over group of wires.
- i. After required contacts (036053-0000 or 036054-0000) have been crimped to wires, install end bell and ferrule over group of wires.

NOTE

When placing contacts through grommet, make certain that they will be in line with their respective lettered cavities in insulator.

- j. Insert contact into connector insulator cavity and press firmly against undercut area of contact with insertion tool 036069-0000 until contact snaps into place (an audible click is heard). Insert contacts at top of insulator first, and gradually work toward bottom.
- k. Slide grommet down against insulator, then press wire hole fillers KM20 into all unused contact cavities as far as possible. When wire hold filler KM20 is correctly positioned, it will be approximately flush with face of connector insulator on connector mating side.
- l. With all contacts and wire hold fillers inserted, press the ferrule, grommet, and end bell down until end bell is fully seated against shell, then evenly tighten setscrews.
- m. Attach saddle with both screws and tighten until 1/16 inch space is left between saddle and body. Apply protective wrap/cushioning so as to bulge slightly when saddle is tightened to prevent any strain from being placed on the contacts.

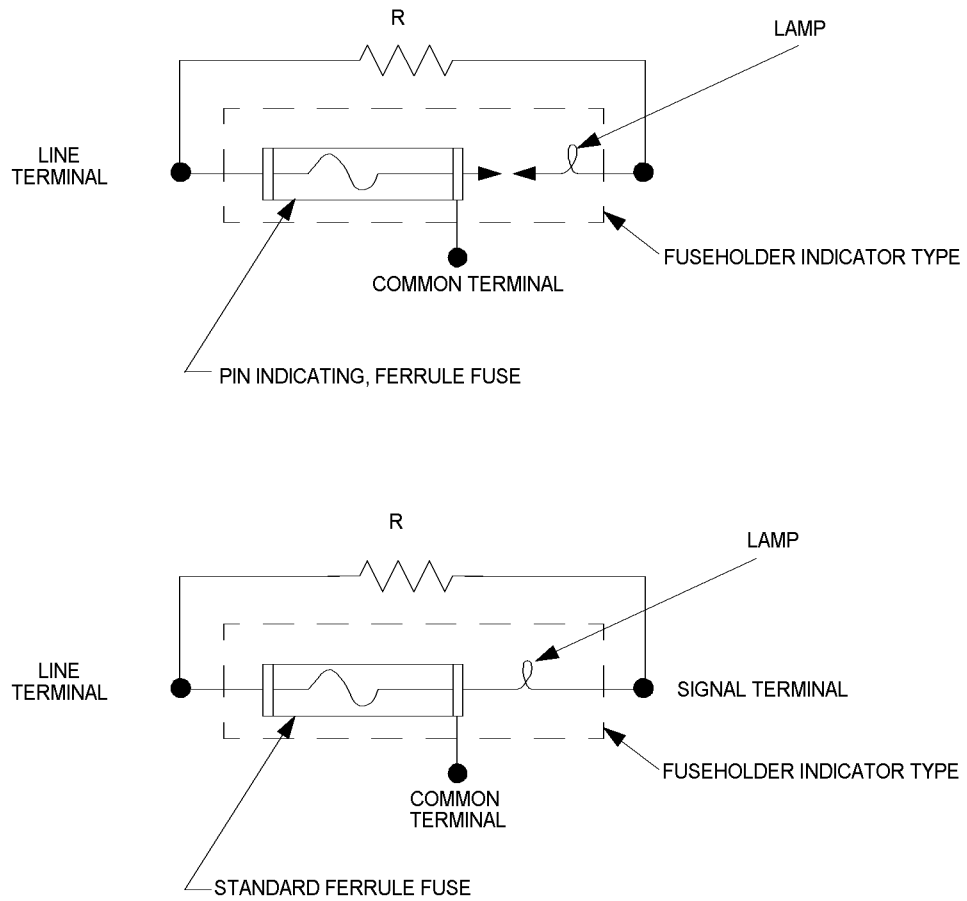

TO-00-25-234-068

Figure 4-65. Wiring Diagrams For Indicator Type Fuse Holders

TO 00-25-234

4.24.13 **Power Cords and Plugs.** Use power cords and plugs of the approved type in accordance with qualified products lists, applicable technical orders and specifications, or other official directives. The power cord assembly must be listed or labeled in accordance with the National Electrical Code.

a. Repair power cord insulation (Figure 4-66) damaged to a maximum depth of $\frac{3}{4}$ the original thickness, as follows:

- (1) Buff damaged area with suitable abrasive to remove all loose material and clean up rough edges of the cut or abrasion.
- (2) Clean buffed area with naphtha or use a cleaning agent recommended by the manufacturer of the sealing compound used.

WARNING

Sealing compound is toxic to skin, eyes, and respiratory tract. Skin and eye protection required. Avoid all skin contact. Good general ventilation normally adequate.

- (3) Apply sealing compound in accordance with manufacturer's directions. If the repair is very deep, the compound will be applied in layers. Allow sufficient time for curing between layers.

- (4) Remove excess sealing compound from repaired area by buffing. Smooth repair to same dimensions as cable.
- (5) Inspect repair for loose edges. A positive bond must exist between repair and parent material.
- (6) Apply protective coating to repaired area.

NOTE

Use Sealing Compound Specification MIL-S-8516B, Presstite No. 106.5 or EC-1120 or equivalent for making this repair.

- b. Replace power cords if insulation is damaged to a depth greater than $\frac{3}{4}$ the original thickness, (or, if applicable, repair per TO 1-1A-15) or if the insulation is brittle, cracked, weathered, or shows overheating.

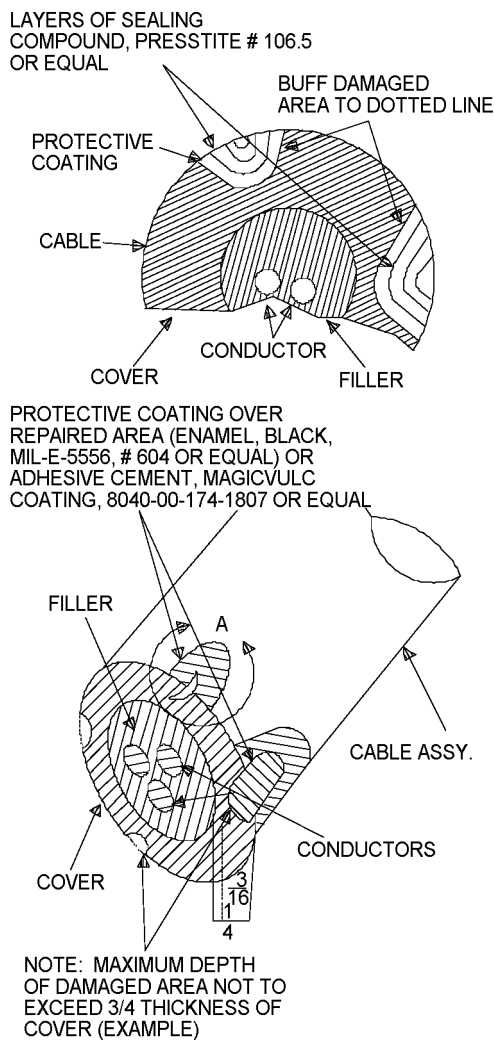

TO-00-25-234-069

Figure 4-66. Repair of Power Cords**NOTE**

New replacement plug may have crimp or clamp type connectors. These types do not require connecting wires to be tinned. Most of the new series plug (probably all) will have self-contained cable clamps.

- c. Replace damaged plugs as follows:
- (1) Tin wire ends.
 - (2) Secure cord inside plug so that the tension in the cord will not be taken by the terminal screws.
 - (3) Wrap tinned wire clockwise around plug terminal screw to form a loop.
 - (4) Tighten screw securely.

- d. Install power cords in accordance with TO 33-1-32 (Figure 4-67 of this TO).
- e. Use direct replacement power cords and plugs whenever possible. Composition-type-3-wire plugs may be used.

4.24.14 Controls and Switches. Use controls and switches of the approved type in accordance with qualified products lists, applicable technical orders and specifications, or other official directives.

- a. Maintain mechanical linkage to controls and switches to ensure smooth operation free of binding and backlash. Lubricate linkage when required with lubricant specified in applicable technical order.
- b. Ensure that control settings will not change when equipment is subjected to specific service conditions.
- c. Ensure that control locks will prevent control settings changes when engaged.
- d. Make sure front panel designations are legible.
- e. Replace cracked knobs that do not have metal inserts in accordance with Figure 4-68. Replace cracked knobs when the setscrew threads are stripped and/or obvious slippage of the control knob is detected. Cracked knobs with metal inserts may be used if the outer material is not broken off or loose from the center metal insert.
- f. Replace switches so worn that mechanical indices no longer identify contact positions.
- g. Use switches of same type and same number of positions but higher current carrying capacity. Switches must have self-cleaning contacts and mechanical stops sufficient to ensure positive and repeated operation.
- h. Plastic materials used in RF switches will conform to provisions of Paragraph 4.16.

NOTE

Round shafts of rotary switches and other controls may have a small flat spot field on them where the setscrew makes contact.

4.24.15 Vibration Isolators. Use vibration isolators of the approved type in accordance with qualified products lists, applicable technical orders and specifications, or other official directives.

- a. Replace vibration isolators showing cracks, breaks, deterioration, brittleness, crumbling, tacky surfaces, objectional bloom, etc.

TO 00-25-234

- b. Replace any vibration isolator which, under load, has less than 1/16 inch clearance between the isolated load (equipment case, mounting base or instrument panel) and any horizontal or vertical surface (isolator mounting cup, mounting shelf or aircraft structure). Lowered Mount (part number 102P8) is an exception and has 1/32 inch clearance.
- c. Use direct replacement vibration isolators whenever possible. Use substitute vibration isolators only in times of supply shortage.

4.25 COMPONENT SUBSTITUTION.

Use direct replacement parts in the repair of electronic circuits. If direct replacement parts are not available, substitute parts may be chosen as follows:

4.25.1 Fuses. Paragraph 4.24.1 provides information on fuses.

4.25.2 Resistors. Use direct replacement resistors in critical circuits. Use substitute resistors in non-critical circuits at times of supply shortages, provided tolerance dimensional, and wattage requirements are met. Substitute resistors in categories Step a(1) and Step a(2) below will be replaced only when they fail.

a. Substitute suitable replacements for fixed resistors where space and terminal locations permit if:

- (1) Resistors are of like value and tolerance but higher wattage.
- (2) Resistors are of like value and wattage but closer tolerance.
- (3) Resistors of like value and wattage and wider tolerances measure within the required tolerance.
- (4) Series or parallel combinations of resistors are equivalent to the required resistor in value, wattage, and tolerance. Ensure that each resistor in the combination is operated within its dissipation rating. Example: Two 2500-ohm, 1-watt, 10 percent resistors in series or two 10,000-ohm, 1-watt, 10 percent resistors in parallel could be substituted for one 5000-ohm, 2-watt, 10 percent resistor.

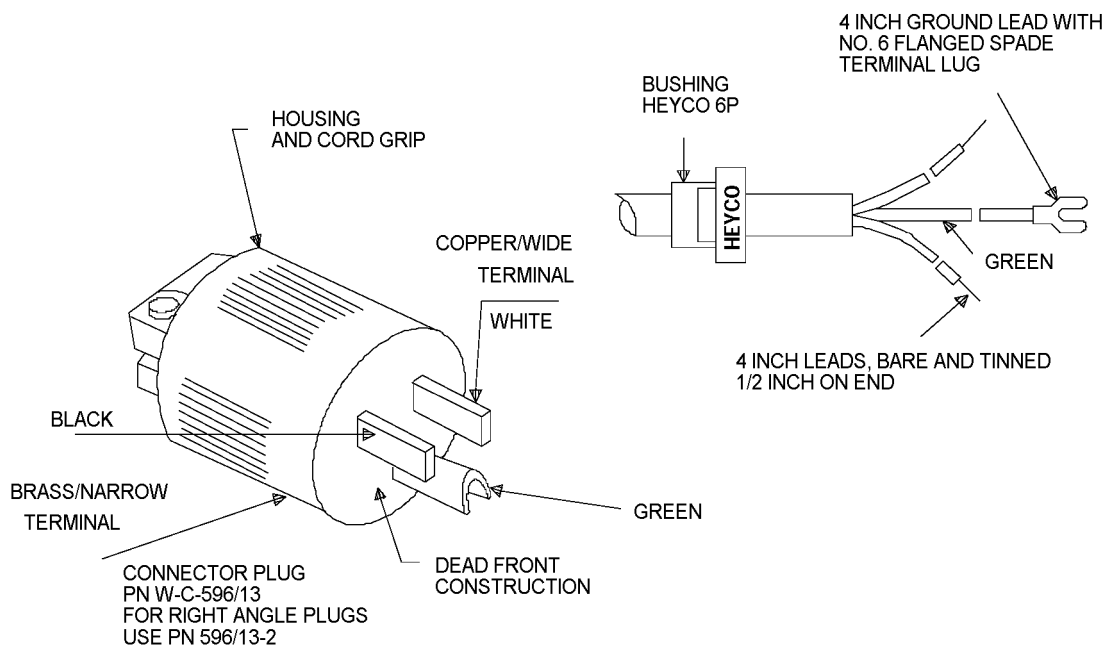

TO-00-25-234-070

Figure 4-67. Power Cord Assembly

- (5) Composition type resistors can withstand potentials 2 1/2 times the continuous working voltage for 5 seconds without damage.
- (6) Wirewound resistors can withstand potentials twice the rated voltage from a direct current source for 30 minutes without damage.

- (7) (Use carbon resistors for wirewound resistors and vice versa if the preceding conditions are met.) Substitutions of this type are not recommended except for extreme necessities as they may introduce errors or changes in broadband circuits or meter circuits. The effects of the inductance of wirewound resistors used in Audio Frequency (AF) and Radio Frequency (RF) circuits must be considered when making this type of substitution.
- (8) Fixed resistors shall not be used as substitutes for variable resistors.

b. Substitute variable resistors only after it has been determined by reference to the characteristics of the items concerned (as listed in parts lists, etc.) that the substitution is feasible.

- (1) Use variable resistors with greater tolerances, or wattage rating, but same ohmic range, taper, and direction of rotation for increasing value. Do not deviate from original taper or direction of rotation for increasing value unless deviations will not result in operational errors. Do not deviate from original ohmic range unless range of substitute control includes original range and range extensions do not cause equipment malfunctions or operational errors.
- (2) Variable resistors shall not be used as substitutes for fixed resistors.

4.25.3 Capacitors. Use direct replacement capacitors in critical circuits of electronic equipments. Use substitute capacitors at times of supply shortages, in noncritical circuits providing tolerance, dimensional, voltage and power requirements are met. Substitute capacitors in categories Step a(1) and Step a(2) below will be replaced only when they fail.

- a. Substitution of suitable replacements for fixed capacitors should be type for type wherever possible. That is, replace a mica capacitor with a suitable substitute mica, etc. Substitution may be made where space and terminal connections permit if:
 - (1) Capacitors are of like capacity, current rating (where applicable), and tolerance, but higher voltage rating.
 - (2) Capacitors are of like capacity, current rating (where applicable), and voltage rating, but closer tolerance.
 - (3) Capacitors of wider tolerance in capacity, current rating (where applicable), and voltage rating, measure within the required tolerance.

- (4) Parallel combinations of capacitors are equivalent to the required capacitor in capacity, voltage rating and tolerance. Series combinations may be resorted to in cases where the circuits are not critical and where the voltages concerned are low. If the circuit voltages are relatively high, use high resistance bleeder resistors across the series combinations.

- b. Substitute variable capacitors only after it has been determined by reference to the characteristics of the parts concerned (as listed in parts lists, etc.) that the substitution is feasible. Use variable capacitors of greater tolerance or higher voltage ratings but same capacity range, current rating, and direction of rotation for increasing value, unless variations do not result in operational errors. Do not deviate from original range unless range of substitute capacitor includes original range and range extensions do not cause operational error or equipment malfunction.

4.25.4 Switches. Ceramic materials used in RF switches can be replaced with plastic if authorized by applicable official directives.

4.25.5 Solid-State Devices. If direct replacement devices are unavailable, a substitute part may be chosen as follows:

- a. Determine critical parameters (such as type, maximum collector-to-emitter voltage, maximum collector current, maximum power dissipation, peak inverse voltage rating, and maximum forward and reverse current ratings) required by the circuit under repair.
- b. Compare circuit parameter requirements with parameters listed in manufacturer's characteristics data.

4.25.6 Electron Tubes. Substitution of tubes with similar or equivalent characteristics should be limited to those types which require no socket connection change (such as 6AG5 and 6186).

4.25.7 Lamps. Use direct replacement lamps. In times of critical supply shortage, for non-critical indications, employ substitution lamps meeting the following conditions:

- a. The substitute shall have the same size and shape as the original.
- b. The voltage rating shall be the same as the original part.

TO 00-25-234

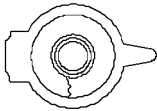
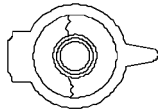
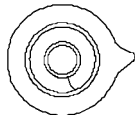
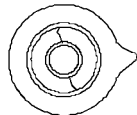
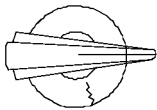
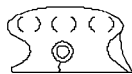
ONE CRACK
PERMISSABLETWO CRACK
NOT PERMISSABLEONE CRACK
PERMISSABLETWO CRACK
NOT PERMISSABLEONE CRACK
PERMISSABLETWO CRACK
NOT PERMISSABLEONE CRACK EXTENDING
THROUGH OUTER SHELL
NOT PERMISSABLEONE CRACK EXTENDING
ABOVE SET SCREW
NOT PERMISSABLE.
ONE CRACK BELOW
SET SCREW
PERMISSABLE.ONE CRACK EXTENDING
ABOVE SET SCREW
NOT PERMISSABLE.
ONE CRACK BELOW
SET SCREW
PERMISSABLE.

TO-00-25-234-071

Figure 4-68. Acceptable and Unacceptable Control Knob Damage

- c. The current rating shall be as close to that of the original as possible.

4.25.8 Neon Lamps. In circuits using neon lamps for overload protection or critical indications, use direct replacement lamps. In times of critical supply shortage, substitute only neon lamps with identical electrical specifications.

4.26 REPAIR OF ELECTRICAL CONTACT STRIPS.

Electrical contact between sliding parts is often made with the use of preformed finger stock, which is a prepared strip of spring material, slotted and formed into a series of fingers.

4.26.1 Description. The material usually used is beryllium copper. There are many sizes and shapes to fulfill the requirements of nearly every sliding contact situation. The material is usually heat treated by the manufacturer to give maximum elasticity and strength. No further heat treating is required.

4.26.2 Areas of Use. Preformed finger stock is used in the following principal areas:

- Radio frequency resonator (cavity) sliding contacts.
- Fixed contacts for coaxial electron tubes.
- High current contacts for non-radio frequency electron tubes.
- General radio-frequency interference shielding on screen-room doors and equipment enclosures.

4.26.3 Problems.

- Poor contact, resulting in burning in case of transmitters or noise in receiver cavities.
- Broken fingers.
- Too much friction, difficult to tune cavity.
- Wear on cavity walls.

4.26.4 Missing or Bent Contacts. The magnitude of the contact problem outlined above depends upon the service the contact is being used. The finger contacts used in radio frequency resonators must make good contact or none at all. A poor contact will result in liberation of heat in transmitter cavities or noise in receiver cavities. Where no contact is made, the fingers are either missing or bent away from the contact surface. Usually, the bent fingers can be bent back to good contact positions without breaking. The number of missing fingers that can be tolerated without erratic electrical performance depends upon the radio frequency wavelength and type of cavity resonator.

4.26.4.1 A general rule for allowable missing contact fingers in a cavity resonator can be made as follows:

- a. Missing fingers shall form a gap no longer than 2% of the wavelength. At 1 GHz this amounts to 0.6 cm, and at 500 MHz this amounts to 1.2 cm. Formulas for determining wavelength (in centimeters) gap and frequency (in megahertz) are:

$$\lambda_{\text{cm}} = \frac{3 \times 10^4}{\text{MHz}} \quad \text{gap} = \frac{\lambda_{\text{cm}}}{0.02} \quad \text{MHz} = \frac{3 \times 10^4}{\lambda_{\text{cm}}}$$

- b. Distance between gaps around a strip of finger stock shall be no less than 2% of the wavelength.
- c. Total loss of contact fingers shall not be greater than 10%.

4.26.4.2 The same rule may be applied to contact fingers for electron tubes in cavity resonators.

NOTE

In case of high power electron tubes in dc and pulse service, the importance of good filament contact is based upon current density. Typical finger contacts (0.06 in. wide) shall not carry more than 2 amp average per contact. Missing fingers cause remaining fingers to pass more current. Missing fingers cause remaining fingers to pass more current. The total number of remaining fingers in this case must be at least half the average current in amperes.

4.26.4.3 For general radio frequency shielding of screen room doors, shielded enclosures, and boxes within equipment, the requirements is not as rigid as for cavity resonators. Radiation from or into such enclosures is usually established by an attenuation specification for the enclosure. Without involved testing, the rules given above may be used.

4.26.5 Manufacturers of Preformed Finger Stock. The following manufacturers are prominent in many varieties of finger stock; Elmac Div., Varian Associates, Palo Alto, CA; Instrument Specialities Co Inc., Little Falls, NJ.

4.26.6 Mounting of Finger Stock. Since contact finger stock is somewhat delicate, mounting or fixing the material to tuning plungers and assemblies should be done in such a manner that it can be replaced easily. Of course, it should be mounted so that it performs the required functions adequately.

4.26.6.1 In those installations where the finger stock is clamped with a strip of heavier metal and screws, the replacement is straightforward and easy. The clamp should conform to the base with a minimum of gaps.

4.26.6.2 Where the finger stock is soldered to the base metal, greater care in preparation must be taken. Only low melting point solder should be used. The highest temperature during the soldering operation should not exceed 550 °F. Lead-tin solder to ASTM-OA (37% Pb, 63% Sn) is satisfactory since it liquefies at 361 °F and has good wetting quality. All old solder should be removed from the part before the replacement finger stock is fitted to ensure a tight fit. It is important that the finger stock conforms to the outline of the part and clamped to avoid gaps. Both the finger stock and part should be pretinned. Heat should be maintained on the assembly being soldered for sufficient time to boil out the flux. Otherwise, bubbles will be formed in the fusion. Corrosive fluxes should not be used.

4.26.6.3 No attempt should be made to silver solder finger stock even though the fingers are cooled. At some point between the heated and the cooled areas, there will be annealing. Grain growth caused by this will produce brittleness and cracking. Replacement will be difficult. Also, to silver solder where previously soft solder was used requires extensive cleaning and machining.

4.26.7 Plating.

NOTE

All personnel performing plating must be certified to Air Force standards.

Silver plating of electronic components is done more for aesthetic reasons than for performance. Plating often causes more problems than it prevents. The difference in performance between silver plated and unplated resonators which are resistive loaded would be difficult to measure. Salts of the solutions used in cleaning and plating remain in the pores of base metal and underneath soldered assemblies, causing subsequent corrosion and embrittlement.

4.26.7.1 If finger stock assemblies must be silver plated, preplating with nickel must not be done as this causes the fingers to become brittle. The following rules are suggested to increase reliability and performance of equipment, reduce repair time, and to converse on an expensive metal (silver):

- Replate only when necessary to cover worn areas. Apply a rhodium flash to extend life of wearing areas.
- Plate component parts before assembly.
- Do not plate finger stock.
- Soft solder finger stock to parts after plating. Pretin stock and parts before soldering. Use an oven, not a torch, to apply heat.

TO 00-25-234

4.26.7.2 To extend life of cavity resonators, use finger stock which has silver deposited on tips of fingers, such as Instrument Specialties Co. "Centips". The soft silver against the rhodium flashed walls of the cavity will reduce wear to the walls. The soft fingers will wear faster and can be replaced without replating the cavity walls.

4.26.8 Assembly of Cavity Resonators. When the moving plungers (tuning assemblies) are placed in the cavity resonators, care must be taken to ensure uniform contact pressure over the entire length of finger stock. This is done by proper alignment of resonator sections and plungers. The contact pressure should not be so great that the tuning plunger is difficult to move or that excessive cavity wall scraping is seen. On the other hand, contacts that are barely touching will overheat and soon burn. If the fingers have not been embrittled by improper plating or softened by heat, they may be bent slightly to produce a proper contact fit in the cavity resonator.

4.26.8.1 Friction and wear in tuned resonant cavities and rotary joints can be considerably reduced by application of a thin film of lubricant to the contact surfaces. The lubricant should be low loss at the microwave frequencies. For low power applications, pure vaseline may be used. Where high power is involved, a silver loaded lubricant should be used. Such a lubricant is manufactured by Technical Wire Products, Inc., 129 Dermody Street, Cranford, NJ 07016. The part number is 72-00016.

4.27 REPAIR OF WAVEGUIDE.

For general repair of rubber coating on waveguide use the following procedure:

- a. Remove damaged RTV coating on Waveguide Coupler (nicks, cracks, loose areas, etc.) using hand tools such as pocket knife or scalpel.

WARNING

Most organic solvents are flammable. Do not use near open flame or spark. Some chlorinated hydrocarbons form phosgene or other toxic chlorides when exposed to flame or excess heat.

- b. Use Environmental Protection Agency (EPA) non-ozone depletion chemicals/solvents or local processes approved for Air Force manufacturer/repair of avionics equipment.

- c. Immediately blow dry all cleaned coated areas on the Waveguide Probe Coupler using compressed air.

WARNING

When using Silicone compounds, wash hands thoroughly before eating, drinking, or smoking.

NOTE

It is important that above material be used in a well ventilated area.

- d. Prepared areas should be filled with black pigmented RTV 3140 silicone (MIL-A-46146, NSN 5970-00-110-8234). A maximum of 2% black pigment (PN 1747) may be used when pigmenting RTV 3140 clear coating.
 - e. After filling damaged areas, immediately apply a final uniform coating (0.020 - 0.030 thick) of RTV 3140 to the remaining silicone surface areas with an acid brush (NSN 7920-00-514-2417).
- 4.27.1 Cure Cycle. Cure the RTV 3140 at standard temperature (75 °F) for 24 hours before putting into operation.

CHAPTER 5

PRINTED CIRCUIT BOARD REPAIR

5.1 GENERAL.

The chapters of this TO that present tools and techniques used in the maintenance and repair of printed circuit boards have been removed from this TO and personnel shall refer to TO 00-25-259, Standard Maintenance Practices Miniature/Microminiature Electronic Assembly Repair, for Printed Circuit Board Repair. TO 00-25-259 discuss printed circuit clas-

sification and manufacturing methods, provides a listing of repair tools and accessories, general precautions, part removal and part terminal replacement. When other technical documents refer personnel to this TO for Printed Circuit Board Repair, TO 00-25-259 maintains precedence and personnel shall refer to TO 00-25-259 for proper repair processes and procedures.

CHAPTER 6

PROTECTIVE COATINGS

6.1 GENERAL.



- Observe precautions for handling electrostatic discharge sensitive items.
- Protective coatings must not be used on printed circuit boards unless the coatings have been proven to be electrochemically compatible with the circuit board and included on QPL-46058.

This chapter established standard procedures for the identification and removal of conformal coating materials on printed circuit board assemblies and for cleaning and recoating the repaired assembly.

NOTE

- The procedures and criteria contained in this chapter are general and do not take precedence over specific procedures and criteria outlined in handbooks and technical orders associated with specific equipment.
- Some steps in Paragraph 6.6 require laboratory techniques for positive identification of coatings. These steps are included to provide a complete procedure and may be either accomplished in the shop or in a laboratory at the discretion of the commands involved.
- Other than tools and materials, the following specifications are referenced in this chapter:

MIL-M-24041	Molding and Potting Compound, Chemically Cured, Polyurethane (Polyether based)
MIL-C-28809	Circuit Card Assemblies
MIL-I-46058	Insulating Compound, Electrical (for Coating Printed Circuit Assemblies)

6.2 SPECIAL TOOLS.

The special tools needed to perform procedures called out in this chapter are listed in Table 1-1.

6.3 SPECIAL MATERIALS.

The special materials needed to perform procedures called out in this chapter are listed in Table 6-1.

Table 6-1. Special Materials for Conformal Coating

Item	NSN/Part Number/Spec
Acetone	NSN 6810-00-223-2739
Morpholine	---
Sodium Nitroprusside	---
Sulfuric Acid	---
Acetic Anhydride	---
Isopropyl Alcohol 99%, TT-I-735,1 Gallon (use of equivalent item available in different quantities permissible).	6810-00-227-0410
Isopropyl Alcohol 70%, 4 Liter, CAGE 22527, (use of equivalent item available in dif- ferent quantities per- missible)	A459-4
Deionized Water PR1592, Part A	---
Curing Agent PR1592, Part B	MIL-M-24041
Base Resin	MIL-M-24041
Organomercurial Urethane Catalyst (Cocure 32)	HMS 20-2023
Litmus paper, blue	NSN 6640-00-290-0146
Cellosolve Acetate Talc Filler (nytal 400)	Commercial solvent MIL-M-15173A
Cab-O-Sil	MIL-S-47129
Dow Corning RTY 3140	MIL-I-46058, Type SR
Dow Corning R-4-3117	MIL-I-46058, Type SR
Catalyst XY-176 Acrylic Conformal Coat	MIL-I-46058, Type AR
Humiseal 1B31, or equivalent	HMS 20-2019, Type I
Primer for Parylene	

TO 00-25-234

**Table 6-1. Special Materials for Conformal Coating
- Continued**

Item	NSN/Part Number/Spec
Varnish, Insulating, Clear	NSN 5970-00-166-1681
Varnish, Insulating, Black	NSN 5970-00-161-1675
Bond Breaker II Bond Breaker Corp Skokie IL 60076	8010PCC16

6.4 SAFETY PRECAUTIONS.

Use care in performing all operations outlined in this chapter. Observe the safety precautions contained in the following paragraphs.

6.4.1 Work Area. Provide a safe work area in the following manner:

- Maintain sufficient illumination.
- Maintain sufficient ventilation.
- Maintain adequate fire-fighting devices at conspicuous accessible locations.
- Maintain first aid equipment at a conspicuous location.
- Keep unused tools and materials in designated locations.
- Clean area as required and temporarily store rubbish in fire-resistant containers.

6.4.2 Rotating Machinery. Machinery operation shall be as follows:

- Allow only authorized personnel to operate machines.
- Do not wear loose clothing while operating machinery.
- Do not allow items to hang or protrude from clothing while operating machinery.
- Protect eyes with safety goggles.

6.4.3 Chemicals. Handle chemicals in the following manner:

- Avoid skin contact with chemicals.
- Wash skin after contacting chemicals.
- Wash hands immediately after using chemicals.

- Ensure adequate ventilation to eliminate hazardous vapor or dust concentrations.
- Provide air respirators in areas where acids, alkalis, cyanides, fluorides, chromates, or organic solvents are used.
- Eye protection should be used.

6.4.4 Electronics. Safety precautions in AFI 91-203, Chapter 8, shall be followed.

6.5 REPAIR SEQUENCE.

Identify the conformal coating, remove the coating, repair the board, and reapply the coating by performing the sequence of operations given in Table 6-2. Each process is discussed in detail in the referenced paragraph.

6.6 IDENTIFICATION OF COATING.

This paragraph provides step-by-step procedures for identifying the five types of conformal coatings.

NOTE

After the coating has been identified, take appropriate action for inclusion in system TO.

6.6.1 Preliminary Identification. There are three methods of identifying conformal coatings:

Systems Technical Orders

Chemical laboratory analysis

Identification per this chapter

Table 6-2. Repair Sequence

Step	Operation	Paragraph Reference
1	Identify conformal coating	Paragraph 6.6
2	Remove conformal coating: a. Polyurethane b. Epoxy c. Parylene d. Acrylic e. Silicone	Paragraph 6.7.1 Paragraph 6.7.1 Paragraph 6.7.2 Paragraph 6.7.3 Paragraph 6.7.4
3	Remove-install components	(Sect. III, V)
4	Wash boards	Paragraph 6.8.1
5	Recoat repaired area:	

Table 6-2. Repair Sequence - Continued

Step	Operation	Paragraph Reference
	a. Polyurethane	Paragraph 6.8.2
	b. Epoxy	Paragraph 6.8.2
	c. Parylene	Paragraph 6.8.3
	d. Acrylic	Paragraph 6.8.4
	e. Silicone	Paragraph 6.8.5

6.6.2 Types of Coatings. The conformal coatings identified in this chapter are:

Polyurethane (UR)

Epoxy (ER)

Parylene (XY)

Acrylic (AR)

Silicone (SR)

6.6.3 Identification Chart. Figure 6-1 is a flow diagram of the step-by-step procedures for identifying the five types of conformal coatings. Each step and YES/NO decision is accompanied by a paragraph reference to detailed procedures for accomplishing the step.

6.6.4 Inspection. Inspect the pc board for the presence of a coating.

6.6.4.1 Parylene coatings, with their dull luster, transparent (almost colorless) and uniquely uniform thin film, are almost invisible under ordinary light and have a markedly different visual profile than the other generic types of conformal coatings.

6.6.4.2 Uncoated printed wiring boards and parylene coated printed wiring boards visually appear to be almost identical.

6.6.4.3 Carefully inspect the printed wiring board for the presence of a conformal coating. Conformal coatings of acrylic, polyurethane, epoxy, and silicone have a definite gloss that is immediately apparent when compared to an uncoated board or a parylene coated board. The conformal coating can easily be seen as a fillet (Figure 6-2) between the printed wiring board and a flush mounted component such as a resistor or diode.

6.6.5 Ultraviolet Fluorescence.

WARNING

The ultraviolet filter gets extremely hot when light is on. To prevent severe burns, do not touch or bump the filter with exposed part of the body. Ensure that this operation has been reviewed by local Bioenvironmental Engineers or Base Medical Services.

Place the printed wiring board assembly approximately 6 inches below an ultraviolet light source of approximately 254 nanometers and observe for fluorescence. This test is best performed in a darkened area.

6.6.5.1 Uncoated printed wiring board circuit traces and component leads will not fluoresce. If there is uncertainty about the fluorescence, inspect a bare metal component lead. The lead will fluoresce if the board is conformally coated with a QPL parylene but will not fluoresce if the printed wiring board is not conformally coated.

6.6.5.2 An ultraviolet tracer (usually anthracene) is incorporated into parylene at coating time. This is a requirement of MIL-I-46058, paragraph 3.2, for all types of conformal coatings. Parylene coated printed wiring boards exhibit a definite fluorescent which can be compared to a known parylene coated sample. A convenient place to look for fluorescence is on a bare metal component lead.

6.6.6 Acetone Test.

WARNING

Acetone is flammable and toxic to eyes, skin, and respiratory tract. Skin/eye protection required. Avoid repeated/prolonged contact. Good general ventilation is normally adequate. Keep away from open flames or other sources of ignition.

Place one drop of reagent grade acetone with an eyedropper or microdropper on a spot on the printed wiring board away from wire traces or components. The acrylic coatings in the QPL are readily soluble in acetone and will quickly soften and dissolve. When gently rubbed with a cotton tipped applicator the spot will have distinct depression where the coating has been removed or smeared. None of the other generic types of conformal coatings will dissolve. A slight swelling of the other generic coating types may occur where the acetone has met the surface, but these coatings will not dissolve or soften.

TO 00-25-234

6.6.6.1 If the coating has not dissolved it is either silicone, polyurethane, or epoxy.

6.6.6.2 If the coating has dissolved it is an acrylic.

6.6.7 **Fingernail Test.** Run a fingernail across a clear section of the printed wiring board away from areas of high component density. Note the hardness, texture, and ease with which the fingernail slides or drags across the surface (Figure 6-3).

6.6.7.1 If the coating is hard and smooth, a fingernail will not penetrate, but will slide easily over the coatings surface with little or no apparent drag; the conformal coating may be an epoxy or a hard polyurethane type of conformal coating. Compare the results of the unknown test specimen to results obtained from known sample specimens of epoxy and hard polyurethane types.

6.6.7.2 If the coating is soft and rubbery, can be penetrated by the fingernail, and the surface causes the fingernail to drag when attempting to slide over the surface, the conformal coating is a silicone or soft polyurethane. Compare the feel of the unknown test specimen to known samples of silicone or soft polyurethane.

6.6.8 Burn Test.**WARNING**

Accomplish this test in a fume hood where the presence of an open flame will not be a safety hazard. Do not inhale the smoke or gasses.

Carefully carve out a small sample of the conformal coating at least one millimeter by five millimeters in size using a sharp knife. Be careful not to cut into the printed wiring board's substrate materials, conductors, or components. Grasp the sample in the jaws of a pair of stainless steel tweezers. Carefully bring the flame of a match or a disposable butane cigarette lighter up to the sample and leave the tip of the flame in contact with the sample until the sample begins to ignite. Remove the flame. Observe the color of the flame, the color and behavior of the smoke, and the character and color of the residue or ash.

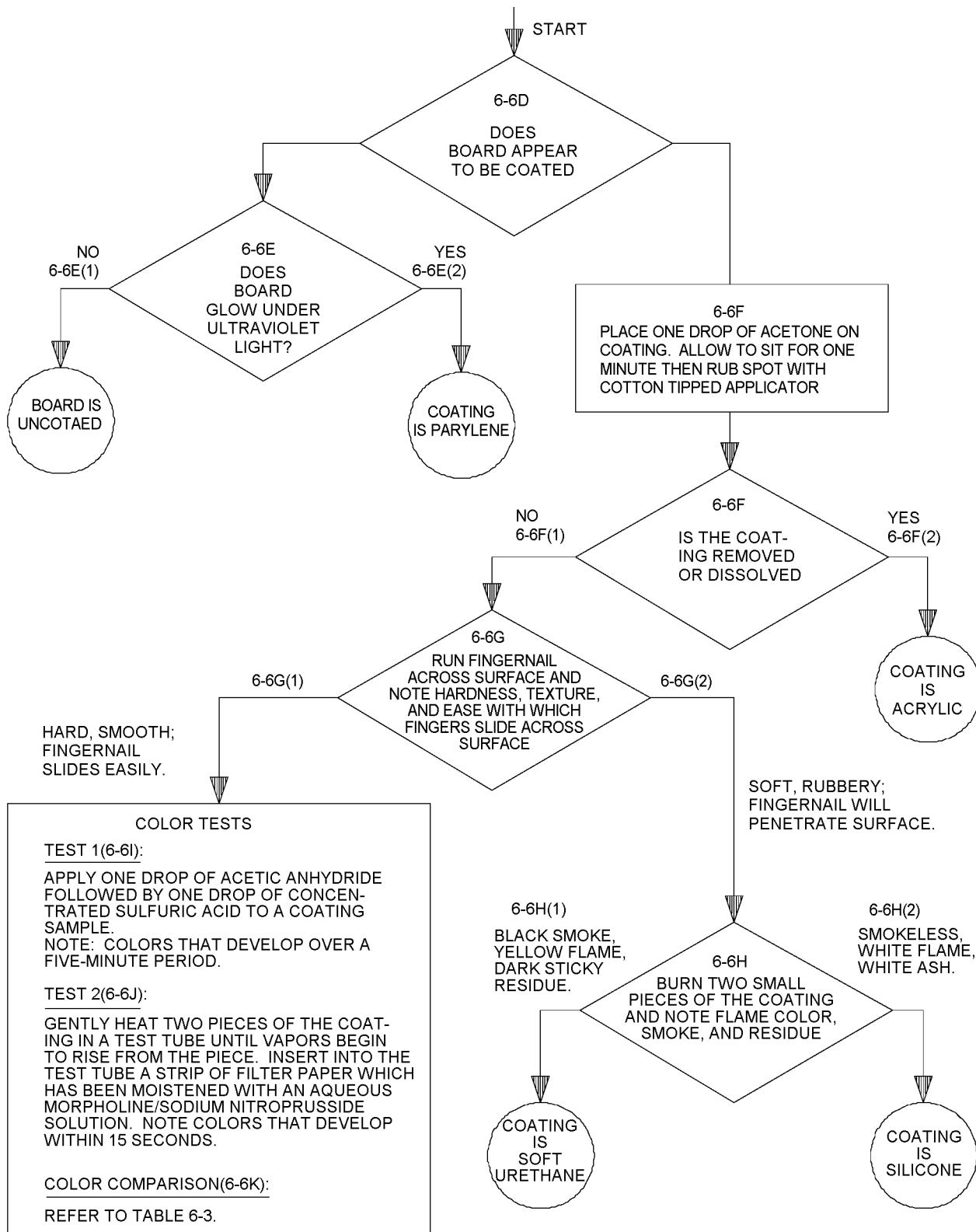

TO-00-25-234-072

Figure 6-1. Flow Diagram for Identification of MIL-I-46058 Conformal Coatings

TO 00-25-234

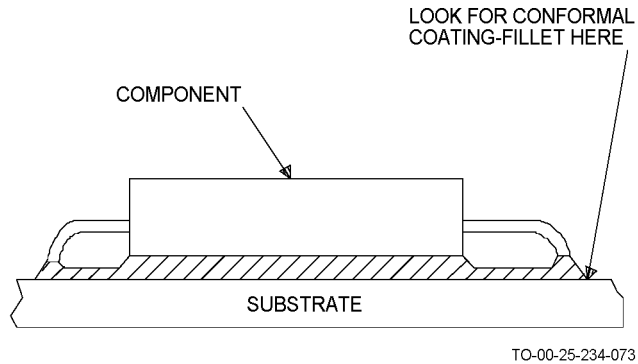

TO-00-25-234-073

Figure 6-2. Conformal Coating Fillet

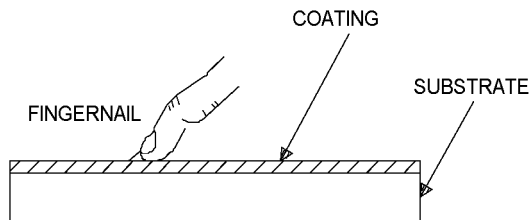

TO-00-25-234-074

Figure 6-3. Fingernail Test

6.6.8.1 If the sample burns with a distinctively yellow flame and gives off large amounts of black sooty smoke and deposits a dark brown or black sticky residue, the conformal coating is a soft polyurethane. The only soft polyurethane listed in the QPL is Uralane 5750-A/B (manufactured by Furane Plastics). Burn a known sample, if available, of soft polyurethane coating and compare burning behavior. The residue can be checked for stickiness by gently probing it with the end of the stainless steel tweezers.

6.6.8.2 If the sample burns with a bright white flame giving off white smoke and leaves a white or grey ash which easily crushes into a dry powder when pressed between the fingers, the conformal coating is a silicone. Burn a known sample of silicone coating material and compare results.

6.6.9 Color Test 1.

WARNING

Acetic anhydride and sulfuric acid are highly toxic to eyes, skin, and respiratory tract. Avoid all contact. Skin and eye protection is required. Use only with adequate ventilation.

- Apply one drop each of reagent grade acetic anhydride and concentrated sulfuric acid to a spot on the surface of the printed wiring board at a position as far away from components and wire traces as possible.
- Note the colors that develop within 5 minutes.
- Carefully rinse off the applied chemicals with distilled or deionized water in a manner that will not allow the rinse water to contact components or connectors.
- Observe whether the spot on the conformal coating has been colored by the applied chemicals. The formation of an intense brown, black, or orange color in the acetic anhydride/sulfuric acid mixture when placed on the conformal coating for five minutes and a dark colored spot left on the coating when the chemicals are rinsed away with water, indicates that the coatings are hard polyurethanes. Epoxy coatings are not usually affected by the acetic anhydride/sulfuric acid mixture.

6.6.10 Color Test 2.

- With a sharp knife, carefully remove two pieces of conformal coating and place the two pieces in the bottom of a clean 10 x 75 millimeter borosilicate glass test tube (KIMAX # 45042 or equivalent).
- Secure the test tube in a clamp as shown in Figure 6-4. Heat the bottom of the test tube with the flame of a disposable butane cigarette lighter. Be sure to position the lighter so that the bottom of the test tube is in the middle of the flame as shown in Figure 6-4. If the sample is carefully observed, vapors will be seen rising from the heated samples.
- Carefully insert a strip of filter paper (3 in x 1/16 in.) which has been moistened with a freshly prepared mixture of equal volumes of a 20 percent by weight aqueous solution of reagent grade morpholine and a 5 percent by weight aqueous solution of sodium nitrop-russide into the vapors. A more or less intense blue or reddish blue color indicates that the conformal coating is an epoxy tube.

6.6.11 Color Comparison. Table 6-3 lists the results of the color tests and identifies the associated coating type.

Table 6-3. Color Test and Identification of Conformal Coatings

Item	Coating type	Manufacturer's designation	Manufacturer	Test 1 color (color of spot after rinse)	Test 2 color
1	AR	1B3	Humiseal Div.	Yellow green (yellow)	No color
2	AR	1B73	Humiseal Div.	Faint yellow (white)	No color
3	ER	Unicoat 2081-31A/B	Amicon Corp.	Pale yellow	Blue
4	ER	R84-G	Co-Polymer Chemicals	Orange brown (slight brown)	Red blue
5	ER	2A53	Humiseal Div.	Faint orange (no color)	Red
6	ER	PC12-007M	Hysol Div.	Faint orange (no color)	Red blue
7	ER	PC16M	Hysol Div.	Faint yellow (no color)	Red blue
8	ER	PC17M	Hysol Div.	Faint yellow (no color)	Red blue
9	SR	3140 RTV with 1204 primer	Dow Corning Corp.	No color	No color
10	SR	R-4-3117 with 1204 primer	Dow Corning Corp.	No color	No color
11	UR	Conathane CE-1155	Conap, Inc.	Orange (orange)	No color
12	UR	Conathane CE-1155-35	Conap, Inc.	Orange (orange)	Red blue
13	UR	Conathane CE-1164	Conap, Inc.	Orange (orange)	No color
14	UR	Uralane 5750-A/B	Furance Plastics (soft polyurethane)	Dark brown (brown)	Faint blue
15	UR	1A20	Humiseal Div.	No color development	No color to faint green
16	UR	1A33	Humiseal Div.	Dark brown (brown)	No color
17	UR	2A64	Humiseal Div.	Orange (orange)	No color
18	UR	PC18M	Hysol Div.	Faint yellow (faint yellow)	Red blue
19	UR	PC29M	Hysol Div.	Faint orange (faint orange)	No color
20	UR	PR-1568	PRC Corp.	Dark brown (brown)	No color to faint green
21	XY	Parylene	Union Carbide	No color development	No color

NOTE

The color tests alone will not conclusively differentiate between epoxy and polyurethane coatings. This requires that infrared spectroscopy be used in conjunction with or in place of the color tests when access to an infrared spectroscopy facility is available.

hole soldered components are encountered, the coating must be removed from the solder joints on both sides of the printed circuit board. The conformal coating must also be cut and separated around the body of each component to be replaced. Use the PRC-151 soldering center to provide hot air, mechanical abrasion, or thermal parting. Chemicals can also be used.

6.7 REMOVAL OF COATING.

Control chemicals used for removal of coatings. Do not allow chemicals to spread outside the repair area, causing damage to identification markings, the board itself, or adjacent components.

The conformal coating material must be removed from all solder joints of the component to be replaced. If through-

NOTE

- Particles of solder imbedded within conformal coating must be removed when cleaning solder joints and surfaces.
- Soldering tips used for removal of coatings shall not be used for desoldering or soldering.

6.7.1 Polyurethane and Epoxy.

- a. Remove polyurethane and epoxy coatings from coated surfaces (Paragraph 6.7).

TO 00-25-234

- b. Remove polyurethane coating from a surface-soldered component lead as shown in Figure 6-5.
- c. Remove polyurethane coating from a pad area on a wiring board surface, or portion of a surface conductor, shown in Figure 6-6.
- d. Polyurethane and epoxy finished which coat solder joints can also be partially removed by melting the solder with a soldering iron tip. When melting occurs, the adhesion of coating to solder is destroyed, and, additionally, the coating is broken by the hot iron. If this technique is used, additional coating removal with a hot-knife is necessary before any resoldering is done. As a result of this procedure the hot knife method becomes more efficient and effective. The epoxy forms a loose, fluffy powder and is easily blown from the work area.
- e. After the solder joints are exposed, cut around the body of the component with the hot knife, being careful of the board, circuits, and adjacent components. Also, cut through any filleting material which may be used and around the component. (6-7).

WARNING

Isopropyl Alcohol is flammable and toxic to skin, eyes and respiratory tract. Skin and eye protection is required. Avoid repeated or pro-longed contact.

Use only in well ventilated areas. Do not use synthetic wiping cloths with flammable TT-1-735 isopropyl alcohol. Keep away from open flames or other sources of ignition.

- f. For chemical removal, use "Bond Breaker II". Remove coating from around solder joints, fillets, and component leads by using a small amount of chemical. After solder joints are exposed, neutralize chemical with water then rinse with alcohol and allow to air dry.

6.7.2 Parylene. Remove parylene coating from solder joints by cutting, scraping, and flaking away with an orange stick, knife or tweezers, or other abrasive means listed in Paragraph 6.7. Abrasion with an eraser can also be used to remove parylene coating that is left after initially scraping and flaking away most of the parylene from a coated area. After solder joints are exposed, cut around the body of the component with the X-acto knife, being careful of the board, circuits, and adjacent components. Also cut through any filleting material which is around or under the component. (Figure 6-7.)

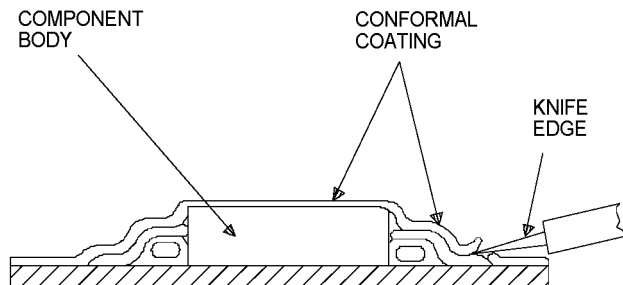
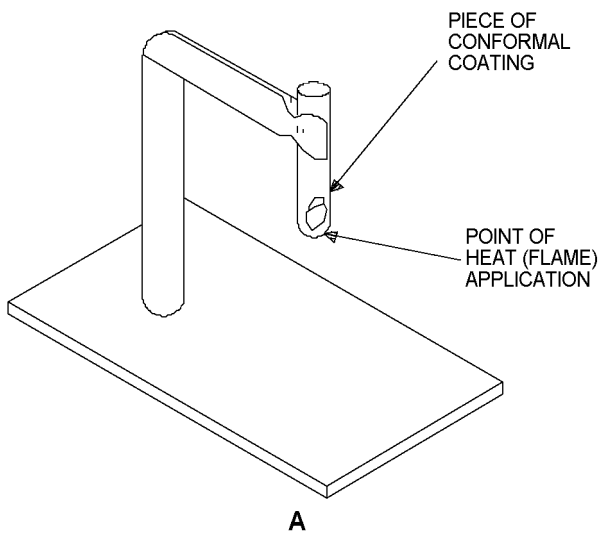

TO-00-25-234-076

Figure 6-5. Removing Polyurethane Coating from Lead

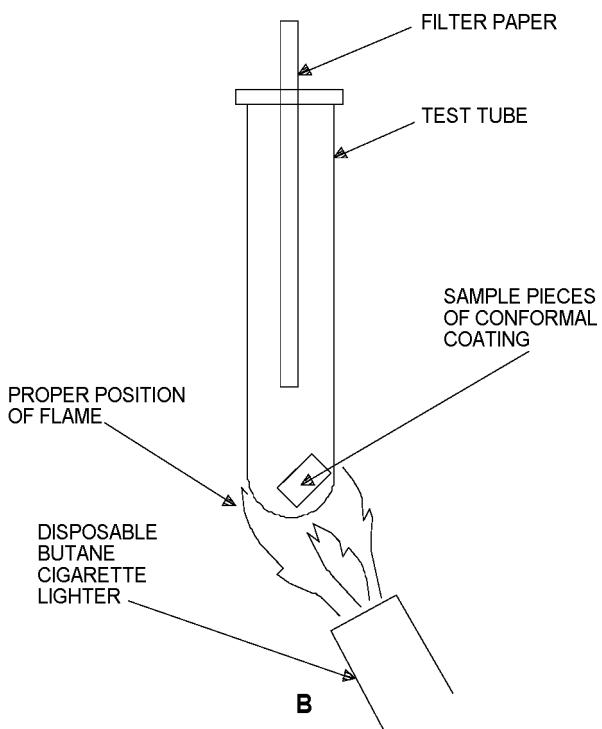

TO-00-25-234-075

Figure 6-4. Color Test 2 Setup

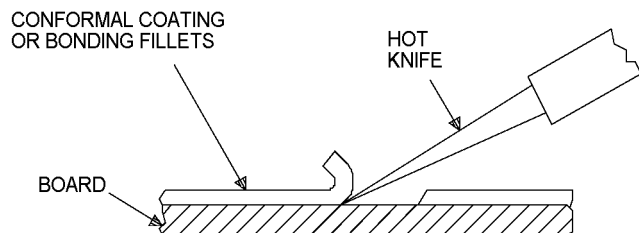

NOTE
TEMPERATURE OF THE HOT KNIFE SHOULD BE SUFFICIENT TO SOFTEN OR MELT THE CASTING WITHOUT ANY CHARRING.

TO-00-25-234-077

Figure 6-6. Removing Polyurethane Coating or Fillets

TO 00-25-234

6.7.3 Acrylic.**WARNING**

- Butyrolactone is flammable. Use only in well ventilated areas, away from open flames or extreme heat. Avoid prolonged contact or inhalation of Butyrolactone vapors.
- Isopropyl Alcohol is flammable and toxic to skin, eyes and respiratory tract. Skin and eye protection is required. Avoid repeated or prolonged contact. Use only in well ventilated areas. Do not use synthetic wiping cloths with flammable TT-I-735 isopropyl alcohol. Keep away from open flames or other sources of ignition.

Remove acrylic coating by dissolving it with a solvent such as Butyrolactone (followed by an alcohol or water rinse). Abrasion and thermal tools of Paragraph 6.7 can also be used. After the coating has been removed, cut through any

filleting material which is around or under the component to be replaced using a knife (Figure 6-7).

6.7.4 Silicone.**WARNING**

Use caution when using sharp or pointed tools to prevent injury to personnel or damage to equipment.

Remove silicone coating around solder pads, fillets, and component leads using a knife, A-A-50177, or abrasion method of Paragraph 6.7. Avoid mechanical tools such as soldering irons or hot-knives since the coating will degrade on the hot surface and ruin its effectiveness. After coating has been removed from solder joints, cut around the body of the component with a knife, being careful of the board, circuit, and adjacent components. Also, cut through any filleting material which is around or under the component (Figure 6-7).

Table 6-4. Coating Repair Process

Conformal coating type	Recoating material	Surface Preparation Method	Application Method
Polyurethane	1. MIL-M-24041, PR 1592 recoat system 2. MIL-I-46058, Type UR	Solvent wipe with isopropyl alcohol.	Brush (2 coats) (Paragraph 6.7.1)
Epoxy	1. MIL-M-24041, PR 1592 recoat system 2. MIL-I-46058, Type ER	Solvent wipe with isopropyl alcohol.	Brush (2 coats) (Paragraph 6.7.1)
Parylene	MIL-M-24041, PR 1592 recoat system	1. Solvent wipe with isopropyl alcohol 2. HMS 20-2019, Type I Primer.	Brush (2 coats) (Paragraph 6.7.2)
Acrylic	MIL-I-46058, Type AR	1. Degreasing. 2. Five rinses of deionized water and isopropyl alcohol.	Dip coating (Paragraph 6.7.3)
Silicone	MIL-I-46058, Type SR, Dow Corning R-4-3117	1. Light sanding. 2. Solvent wipe with isopropyl alcohol.	Brush (2 coats) (Paragraph 6.7.4)

NOTE

Use Environmental Protection Agency (EPA) nonozone depletion chemical/solvents or local processes approved for Air Force manufacturer/repair of avionics equipment.

6.8 RECOATING REPAIRED AREAS.

Three methods are provided for recoating of the five coating types which are generally encountered on printed circuit board assemblies. Table 6-4 summarizes the systems and

general processing methods. Specific materials and processes are in the following paragraphs.

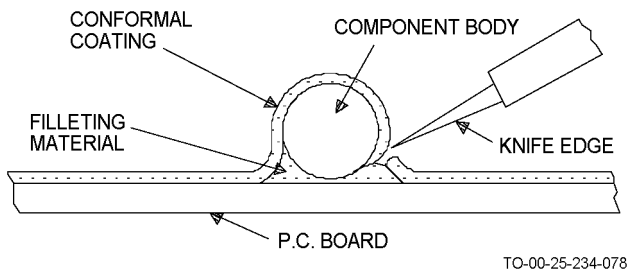

Figure 6-7. Removing Coatings and Fillets from Axial Components

6.8.1 Washing of Boards.

WARNING

- Coating compounds must be prepared and applied in a well ventilated area to prevent personal injury.
- Avoid all contact between conformal coating compounds and skin. This material can cause physical disorders.
- Eye and nose areas affected must be flushed immediately with clean water and personnel referred to medical aid for required treatment.

NOTE

- Prior to recoating boards they must be washed in deionized water (Paragraph 6.8.1).
- Cleaned assemblies require protection from dust and contamination until the conformal coating has been applied.
- Filletting, when required, must be performed within 12 hours after an oven-dry or forced-cure operation.

Wash boards prior to recoating.

- a. Clean in isopropyl alcohol conforming to TT-I-735. If necessary, scrub thoroughly with a stiff-bristled brush

to remove flux residues. Use rubber gloves or finger cots to handle the edges of the board assembly to avoid further contamination.

- b. Rinse thoroughly with clean isopropyl alcohol or other cleaning solvent.
- c. Rinse thoroughly with de-ionized or distilled water under pressure or agitation.
- d. Air dry printed circuit assemblies (PCA) for 15-30 minutes.
- e. Oven dry PCAs for 2-3 hours at 60°C or 1-2 hours at 75°C.
- f. Remove PCAs and allow them to stabilize at room temperature. PCAs should be coated as soon as possible after stabilizing at room temperature.

6.8.2 Polyurethane and Epoxy Coated Boards.

WARNING

- Ensure that heat-resistant gloves are used when handling hot modules. Handling hot modules without protective gloves can cause injury to personnel.
- Isopropyl Alcohol is flammable and toxic to skin, eyes and respiratory tract. Skin and eye protection is required. Avoid repeated or prolonged contact. Use only in well ventilated areas. Do not use synthetic wiping cloths with flammable TT-I-735 isopropyl alcohol. Keep away from open flames or other sources of ignition.
- Provide adequate ventilation when using these materials. Avoid prolonged breathing of vapors and minimize skin contact.

CAUTION

Ensure that modules are not subject to temperatures exceeding 150 °F (65.6 °C). Temperatures exceeding 150 °F (65.6 °C) can cause module degradation.

Table 6-5. Polyurethane Recoat System

Materials	Materials Description	Parts by Weight **	
		Undercoat	Topcoat
MIL-M-24041 curing agent	PR 1592, Part A	43.0±0.5	43.0±0.5
MIL-M-24041 base compound	PR 1592, Part B	100.0±1.0	100.0±1.0
HMS 20-2023 *	Organomercurial urethane catalyst (Cocure 32)	4.0±0.5	4.0±0.5
Solvent blend (50/50) mixture of cellosolve acetate and acetone.	Cellosolve acetate and acetone	45.0±1.0	45.0±1.0
MIL-M-15173	Talc filler (Nytal 400)	20.0±0.5	
MIL-S-47129	Cab-O-Sil	2.0±0.5	
	*Hughes Materials Specification, see Appendix C.		
	* *These formulations are available premixed from:		
	Ramtech Laboratories	Ablestik Adhesive Div.	
	14104 Orange Ave.	833 West 182nd St.	
	Paramount, CA 90723	Gardena, CA 90248	

a. Apply undercoat.

- (1) Wipe area to be recoated with clean isopropyl alcohol using a lint-free cotton swab and allow to air dry.
- (2) Use pre-mixed repair materials for PCB(s). Place ingredients in a large plastic cup when mixing. The volume of the cup should be at least 5 times larger than the volume of the contents. Place in a vacuum degassing chamber and carefully apply a vacuum, alternately breaking the vacuum with an air bleed to prevent overflow of the material from the cup. Hold the vacuum until the foaming subsides or collapses. Break vacuum and remove material from chamber. Do not continue to evacuate material after foam collapses or excess solvent will be removed.
- (3) Apply coating by brush over defined area. The pot life is approximately 45 minutes for the polyurethane/ epoxy repair mixture.

NOTE

Any attempt to shorten the air dry period will cause bubbles and microvoids to form in the coating. Additional air dry time is preferred.

- (4) Air dry the coating at room temperature for a minimum of 30 minutes.
- (5) Cure the coating to a recoatable condition in accordance with Figure 6-8 for fresh material, or Figure 6-9 for material near the end of its pot life.

b. Apply top coat.

- (1) Use pre-mixed repair material for PCB(s). Place ingredients in a large plastic cup when mixing. The volume of the cup should be at least 5 times larger than the volume of the contents. Place in a vacuum degassing chamber and carefully apply a vacuum, alternately breaking the vacuum with an air bleed to prevent overflow of the material from the cup. Hold the vacuum until the foaming subsides or collapses somewhat. Break vacuum and remove material from chamber. Do not continue to evacuate material after foam collapse or excess solvent will be removed.
- (2) Apply coating by brush over precoated area.

NOTE

Any attempt to shorten the air dry period will cause bubbles and PF3voids to form in the coating. Additional air dry time is preferred.

- (3) Air dry the coating at room temperature for a minimum of 30 minutes.
- (4) Cure final coating application to handling condition in accordance with Figure 6-8 and Figure 6-9. This processing is sufficient to allow the part to be handled, tested, or installed into equipment.

6.8.3 Parylene Coated Boards.

- a. Apply primer.

WARNING

- HMS 20-2019 Type I primer is flammable and toxic to eyes, skin, and respiratory tract. Skin/eye protection required. Avoid repeated/prolonged contact. Good general ventilation normally adequate. Keep away from open flames or other sources of ignition.
 - Isopropyl Alcohol is flammable and toxic to skin, eyes and respiratory tract. Skin and eye protection is required. Avoid repeated or prolonged contact. Use only in well ventilated areas. Do not use synthetic wiping cloths with flammable TT-I-735 isopropyl alcohol. Keep away from open flames or other sources of ignition.
- (1) Wipe area to be recoated with clean isopropyl alcohol using a lint-free cotton swab allow to air dry.
 - (2) Apply a thin coat of HMS 20-2019 Type I primer to the repaired area using a brush. Primer should overlap onto the adjacent parylene coating by at least 1/4 inch.
 - (3) Dry primer for 5 minutes at room temperature followed by at least 10 minutes at 140 ± 10 °F (60 ± 5 °C).

b. Apply undercoat.

- (1) Mix the undercoat material per formulation in Table 6-5 or use premixed material. Place ingredients in a large plastic cup when mixing. The volume of the cup should be at least 5-times larger than the volume of the contents. Place in a vacuum degassing chamber and carefully apply a vacuum. Alternately breaking the vacuum with an air bleed to prevent overflow of the material from the cup. Hold the vacuum until the foaming subsides or collapses. Do not continue to evacuate material after the collapse or excess solvent will be removed. Break vacuum and remove material from chamber.
- (2) Apply coating by brush over defined area. When applying the first coat over the primed surfaces, apply the coating rapidly and with a minimum number of brush strokes in any given location. If the proper brush is selected, one or two strokes will be sufficient. Additional strokes of the brush may disturb or dissolve the underlying primer necessary for good adhesion. There must be visible evidence of the primer coat extending be-

yond the area to which the repair coating has been applied, and the repair coating must overlap the adjacent undisturbed conformal coating surrounding the area recoated. The pot life is approximately 45 minutes for the polyurethane repair mixture.

NOTE

Any attempt to shorten the air dry period will cause bubbles and microvoids to form in the coating. Additional air dry time is preferred.

- (3) Air dry the coating at room temperature for 30 minutes minimum.
- (4) Cure the coating to a recoatable condition in accordance with Figure 6-8 for fresh material or Figure 6-9 for material near the end of its pot life.

c. Apply top coat.

- (1) Use pre-mixed repair materials for PCB(s). Place ingredients in a large plastic cup when mixing. The volume of the cup should be at least 5 times larger than the volume of the contents. Place in a vacuum degassing chamber and carefully apply a vacuum, alternately breaking the vacuum with an air bleed to prevent overflow of the material from the cup. Hold the vacuum until the foaming subsides or collapses somewhat. Break vacuum and remove material from chamber. Do not continue to evacuate material after foam collapse or excess solvent will be removed.

- (2) Apply thin coating by brush over precoated area.

NOTE

Any attempt to shorten the air dry period will cause bubbled and microvoids to form in the coating. Additional air dry time is preferred.

- (3) Air dry the coating at room temperature for 30 minutes minimum.
- (4) Cure final coating applications to handling conditions in accordance with Figure 6-8 or Figure 6-9. This processing is sufficient to allow the part to be handled, tested, or installed into equipment.

6.8.4 **Acrylic Coating.** Boards to be acrylic coated must have all coating material removed (Paragraph 6.6.3).

6.8.4.1 Acrylic recoating is done using MIL-I-46058, Type AR conformal coating material.

TO 00-25-234

6.8.4.2 Accomplish recoating using material manufacturer's instructions. Dip coating is the preferred method of coating application as spraying can leave voids in hard-to-reach areas.

6.8.5 Silicone Coated Boards.

a. Prepare surface.

WARNING

Isopropyl Alcohol is flammable and toxic to skin, eyes and respiratory tract. Skin and eye protection is required. Avoid repeated or pro-longed contact. Use only in well ventilated areas. Do not use synthetic wiping cloths with flammable TT-I-735 isopropyl alcohol. Keep away from open flames or other sources of ignition.

- (1) Lightly sand the remaining silicone coating material in the area to be recoated. Use 400-grit sandpaper.
- (2) Wipe sanded area with clean, reagent grade isopropyl alcohol and let air dry.

b. Apply recoat.

WARNING

Dow Corning R-4-3117 contains xylene. Keep away from heat and open flame. Use only with adequate ventilation. Avoid prolonged breathing of

vapor and prolonged or repeated skin contact. Dow Corning 176 catalyst can cause skin and eye irritation. Mixing reduces this hazard.

- (1) Mix 0.5 parts-by-weight Dow Corning 176 catalyst to 100 parts-by-weight Dow Corning R-4-3117. Pot Life is 7 to 10 days at room temperature.
- (2) Apply R-4-3117 coating by brush to Defined, sanded area.
- (3) Air dry coating at room temperature for a minimum of 15 minutes.
- (4) Dry coating for 15 to 30 minutes at 140 ± 10 °F (60 ± 5 °C).
- (5) Brush apply second coating of R-4-3117 within 15 minutes of intermediate drying sequence.
- (6) Air dry coating at room temperature for a minimum of 15 minutes. Cure for a minimum 30 minutes at 140 ± 10 °F (60 ± 5 °C).

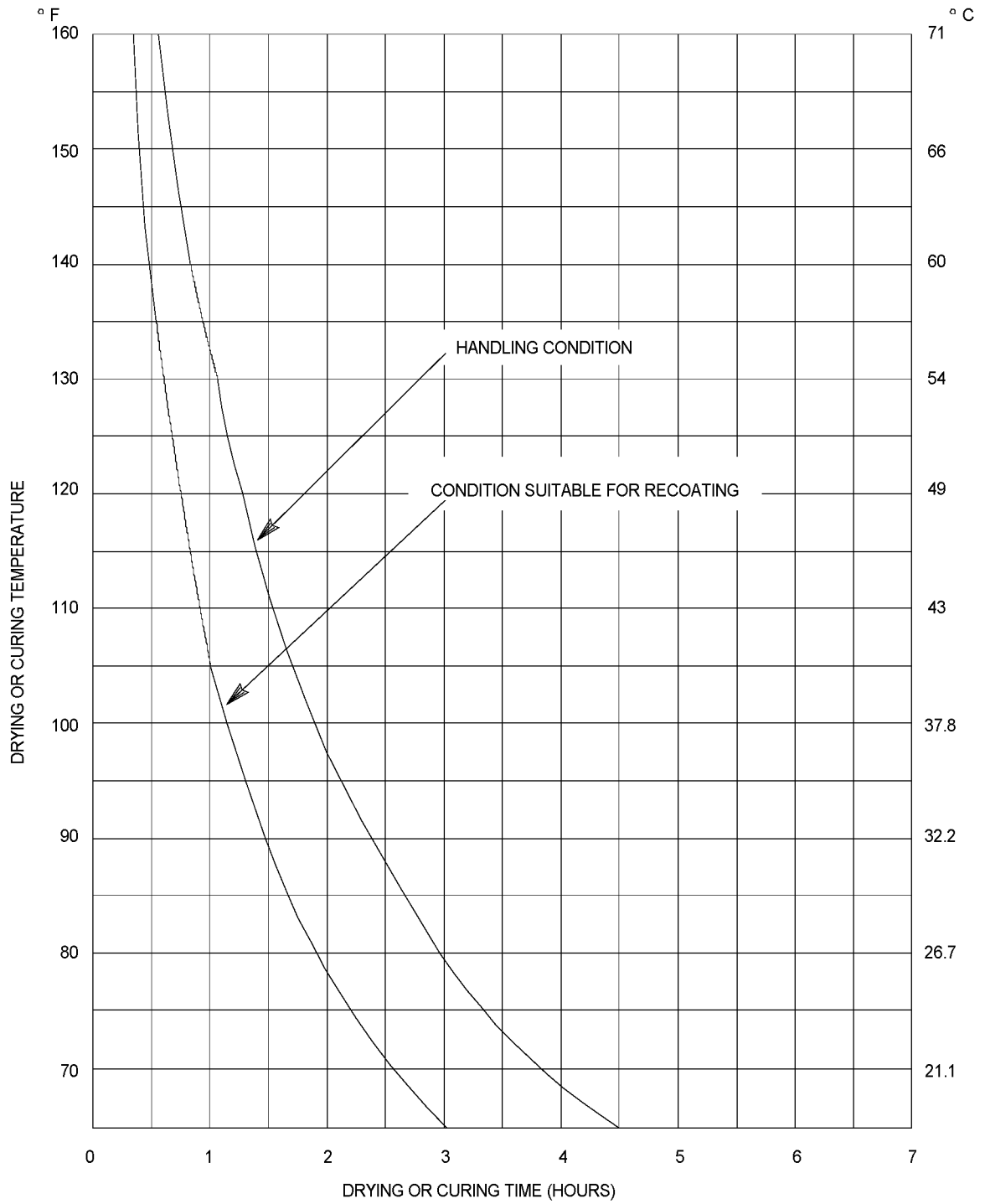

TO-00-25-234-079

Figure 6-8. Drying or Curing Schedule for Coating Material Applied Shortly After Mixing

TO 00-25-234

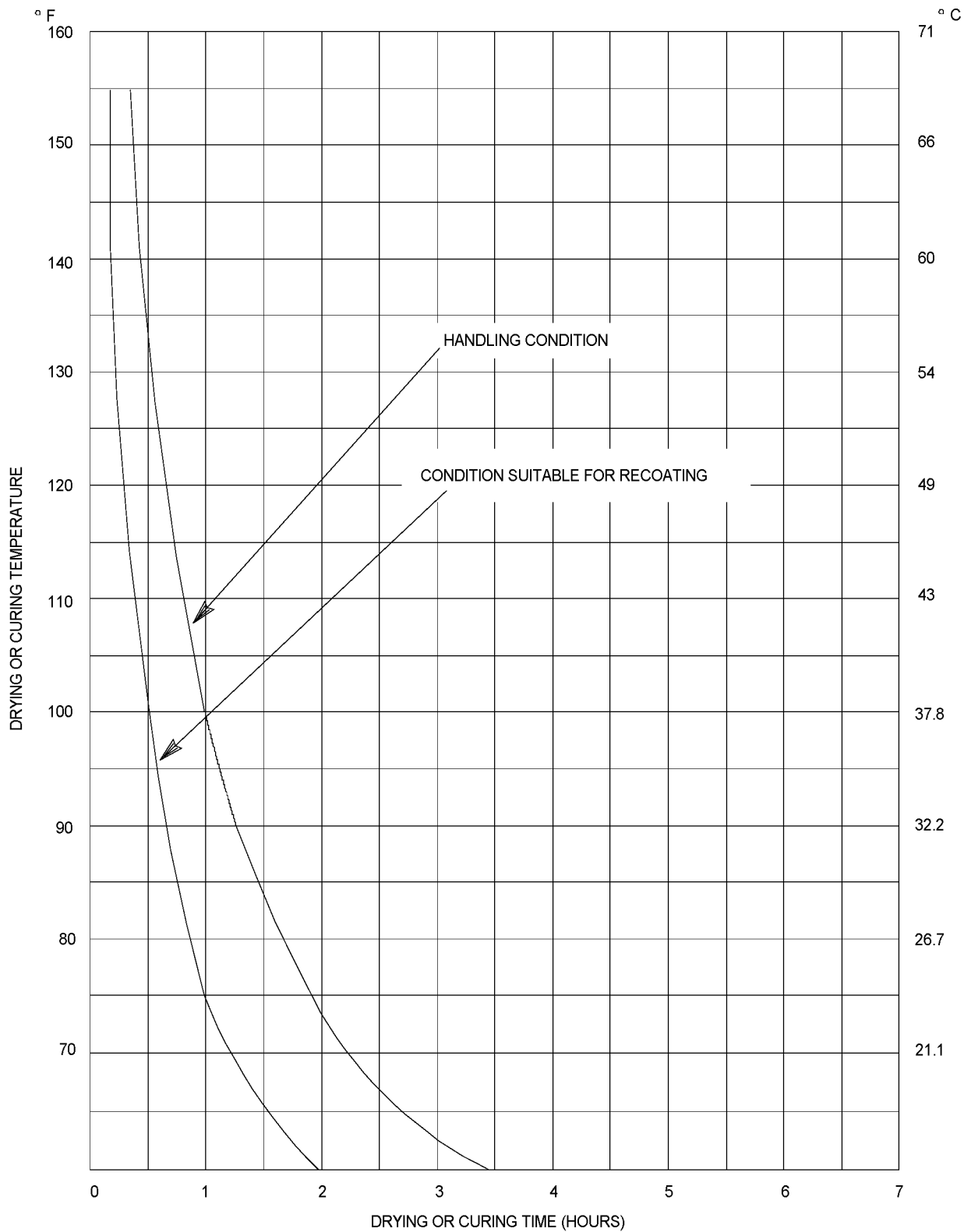

TO-00-25-234-080

Figure 6-9. Drying or Curing Schedule for Coating Material Applied Near End of Work Life

6.9 CONFORMAL COATING OF CERAMIC PRINTED CIRCUITS (CPC'S).

WARNING

Conformal coating is flammable and toxic to eyes, skin, and respiratory tract. Skin/eye protection required. Avoid repeated/prolonged contact. Good general ventilation is normally adequate. Keep away from open flames or other sources of ignition.

Unless otherwise directed, use a polyurethane coating on CPC's.

6.9.1 Preparing Coating Material. Mix the polyurethane coating material (Table 6-5) in a 1-to-1 ratio in a nonporous container. Use the mixture within 4 hours.

6.9.2 Application of Coating. Use brush application for repair and touch-up work to avoid excessive film buildup. Use a soft nylon brush and avoid heavy application of material.

- a. Polyurethane must present a continuous film over re-worked section.
- b. A dry-film thickness of 0.001 inch minimum must be present.
- c. As a minimum, an area no less than 0.030 inch outside the component's edge will be coated. Coating must cover all circuitry.
- d. Use a combination of brush-out and flow-out to ensure coverage of difficult areas.
- e. Avoid excessive accumulation of polyurethane around the base of components.
- f. Brush out entrapped air bubbles.
- g. Dry in a horizontal position.

6.9.3 Curing the Coating. Unless otherwise indicated air-dry shall be done in a vented, dust-controlled chamber at 74 °F ±2 °F. Force drying shall be done in a vented oven or hot plate capable of maintaining temperature within ±7 °F.

- a. Curing for in-between coat for touch-up and rework must be a minimum of 60 minutes air dry.
- b. Final coat cure must consist of a minimum of 60 minutes air-dry, plus one of the following:

- (1) 5 days minimum air-dry.
 - (2) 6 hours minimum at 90 °F (32.2 °C).
 - (3) 3 hours minimum at 115 °F (46.5 °C).
- c. Post-cure 5 days at 70 °F to 85 °F (21.1 °C to 29.4 °C) (not necessary in a drying chamber) before exposure to chemical or environmental testing.

6.9.4 Cleanup.

WARNING

Isopropyl Alcohol is flammable and toxic to skin, eyes and respiratory tract. Skin and eye protection is required. Avoid repeated or pro-longed contact. Use only in well ventilated areas. Do not use synthetic wiping cloths with flammable TT-I-735 isopropyl alcohol. Keep away from open flames or other sources of ignition.

Clean up tools and equipment before the polyurethane has had an opportunity to set up. In the uncured state, it may be easily removed with a mixture of approximately two parts acetone and one part isopropyl alcohol.

6.10 PROTECTIVE COATING ACCEPTANCE.

Unless otherwise specified by design or official directive, criteria for protective coating (sealed or encapsulated) are as follows:

- a. All printed wiring pattern, solder connections, and parts shall be completely covered.
- b. All areas making electrical contact (such as connector pins and terminals) with other assemblies and adjustment screws shall be free of protective coating.
- c. Coating will be from 2 to 8 mils thick. Buildups (fillets) of greater thickness around parts shall be permissible, but obstructionary globules shall not be acceptable.
- d. Bubbles contacting conductive surfaces shall not be permissible. Occasional small bubbles are permissible if protective coating is not impaired mechanically or electrically and when there is no possibility of contamination entrapment or penetration.
- e. Test the coating as follows:

TO 00-25-234



Observe precautions for handling electrostatic discharge sensitive items.

NOTE

Cured compound must be dry hard when inspected. Wear clean protective gloves.

- (1) Support assembly with fingers and rest thumb on recoated film to be inspected.
- (2) Exert a substantial downward pressure (without twisting the thumb) on film.
- (3) Lightly polish area with nylon glove.
- (4) No imprints must be visible.
- (5) Ultraviolet light may be used for coating inspection.

6.11 VARNISH-TYPE COATINGS.

Varnish-type coatings are to be used only when required by equipment specification or by other official directives.

6.11.1 Sealing. Use Insulating Varnish (NSN 5970-00-280-4921). Apply as follows:

- a. Clean area to be sealed with solvent, refer to TO 00-25-259.
- b. Allow sufficient time for cleaned area to dry completely.
- c. Apply insulating varnish to cleaned area.
- d. Dry insulating varnish at room temperature for 24 hours before inspection and testing.

6.11.2 High-Voltage Circuits.

MIL-I-24092 is toxic to skin and respiratory tract. Skin and eye protection required. Avoid repeated or prolonged contact. Good ventilation is normally adequate. Injury to personnel may result if this warning is not observed.

When specified, apply insulating electrical varnish which meets Specification MIL-I-24092, to points in power supplies exposed to high voltage that could cause high altitude arcing. This varnish comes in two grades: Black, Air Drying National Stock Number 5970-00-161-1675 and Clear, Air Drying, National Stock Number 5970-00-166-1681, either of which may be used.

CHAPTER 7

ELECTROSTATIC DISCHARGE CONTROL

7.1 GENERAL.

7.1.1 Purpose. The primary purpose of this chapter is to describe electrostatic discharge (ESD) control measures which shall be employed to minimize the impact of ESD damage to electrical and electronic parts, assemblies and equipment. This chapter explains measures to be taken by all personnel that handle ESD Sensitive (ESDS) items which will prevent ESD damage to electronic parts, assemblies, and equipment.

7.1.2 Scope. Discussed in this chapter is a summary of ESD principles, the nature of the damage it does to electronic devices, and a summary of ESD susceptibility of electronic parts, assemblies and systems. In addition this chapter covers the framework of ESD Control, a summary of required ESD Control procedures for the protection of ESD-sensitive (ESDS) items, descriptions of ESD Control equipment with corresponding stock numbers and specifications, grounding procedures and work area ESD Control survey requirements.

7.1.3 Applicability. Chapter 7 applies to and governs the operating procedures of all personnel who handle, inspect, repair, test, operate and maintain items susceptible to damage from ESD. Questions pertaining to the requirements of this chapter can be directed to the Air Force ESD Control Technology Center at AFRL/RXSA, 2179 12th Street, Building 652, RM 122, Wright-Patterson AFB, OH 45433-7718; Phone DSN 785-2186 or commercial (937) 255-2186.

7.2 REFERENCES.

The following specifications, standards and handbooks are referenced in this chapter. These documents are not directive in nature; therefore, they do not mandate procedures. They do, however, contain detailed information which is needed to carry out ESD Control requirements levied per this technical order (TO). Note that the most current revision of the referenced standards, handbooks and specifications will be used. In the event of inconsistencies between this technical order and the referenced standards and handbooks, this technical order will take precedence.

ANSI/ESD S20.20	Development of an Electrostatic Discharge Control Program for Protection of Electrical and Electronic Parts, Assemblies and Equipment	MIL-HDBK-454	General Requirements for Electronic Equipment
MIL-STD-129	Marking for Shipment and Storage	MIL-HDBK-263	Handbook for Protection of Electrical and Electronic Parts, Assemblies, and Equipment
		MIL-PRF-87893	Workstation, Electrostatic Discharge (ESD) Control
		MIL-PRF-81705	Barrier Materials, Flexible, Electrostatic Protective, Heat Sealable
		MIL-STD-1285	Marking of Electrical and Electronic Parts
		MIL-P-81997	Pouches, Cushioned, Flexible, Electrostatic-Free Reclosable, Transparent
		MIL-B-117	Bags, Sleeves and Tubing
		MIL-STD-883	Test Methods and Procedures for Microelectronics
		ASTM F-150	Standard Test Method for Electrical Resistance of Conductive Resilient Flooring
		PPP-C-1842	Cushioning Material, Plastic, Open Cell (For Packaging Applications; to be replaced by A-A-3129)
		PPP-C-795	Cushioning Material, Flexible, Cellular, Plastic Film for Packaging Applications
		PPP-B-1672	Boxes, Shipping, Reusable with Cushioning
		PPP-C-1752	Cushioning Material, Packaging, Unicellular, Polyethylene Foam, Flexible (to be replaced by A-A-59135 and A-A-59136)
		PPP-C-1797	Cushioning Material, Resilient, Low Density, Unicellular, Polyethylene Foam
		QML-38535	Qualified Manufacturers List of Advanced Microcircuits
		QML-19500	Qualified Manufacturers List for MIL-PRF-19500 Semiconductor devices
		National Electrical Code	(NEC)
		MIL-STD-2073-1	DOD Standard Practice For Military Packaging

TO 00-25-234

MIL-HDBK-773	Electrostatic Discharge Protective Packaging
A-A-3129	Cushioning Material, Flexible Open Cell Plastic Film (For Packaging Applications)
A-A-59135	Packaging Material, Sheet
A-A-59136	Cushioning Material, Packaging, Closed Cell Foam Plank

changed when two substances are rubbed together, separated or flow relative to one another (i.e. one substance gains electrons and the other loses electrons). The charges on these two substances are equal and opposite, and in the case of non-conductors tend to remain in the localized area of contact for relatively long periods of time. Charges generated on conductors are rapidly distributed over their surfaces.

7.3.2 Sources of Static Electricity. Personnel shall be aware of materials and activities which pose hazards as sources of static electricity in the work place. Typical prime charge sources or static generators commonly encountered in the work place are listed in Table 7-1. Most of the items listed are non-conductors (insulators) and are typically synthetic materials. Electrostatic voltage levels generated by insulators can be very high since the charge generated is not distributed over its entire surface. Ungrounded conductors may also generate substantial static levels. Table 7-2 shows typical electrostatic voltage levels generated by personnel.

7.3 SUMMARY OF ESD PRINCIPLES.

7.3.1 Static Electricity. Static electricity is an electrical charge at rest. The electrical charge is due to the transfer of electrons within a body or from one body to another. The magnitude of the charge is dependent on the size, shape, composition, and electrical properties of the substances which make up the bodies. The electrical charge can be

Table 7-1. Typical Sources of Static Electricity

Object or Process	Material or Activity
Work Surfaces	Waxed, painted or varnished surface Common vinyl or plastics Finished wood
Floors	Sealed concrete Waxed, finished wood Common vinyl tile or sheeting High pressure laminates made from insulative materials Carpeted surfaces
Clothes	Common synthetic clean room smocks Common synthetic personnel garments Non-conductive or synthetic shoe soles Virgin cotton (See Note below)
Chairs	Finished Wood Vinyl, plastic Fiberglass Synthetic Fabric
Packaging and Handling	Paper Products Common plastic connector caps or plugs Common plastic-bags, wraps, envelopes Common plastic bubble pack, foam Common plastic trays, tote boxes, vials, parts bins Sufficiently aged anti-static treated bags, wraps, envelopes Tapes, tape dispensers, stickers
Assembly, Cleaning, Test and Repair Areas	Polyethylene bags, pouches Spray cleaners Common plastic solder suckers Solder irons or guns with ungrounded tips Solvent brushes (synthetic bristles) Cleaning with high resistance fluids

Table 7-1. Typical Sources of Static Electricity - Continued

Object or Process	Material or Activity
	Drying, vacuuming or spraying using nozzles made of plastic
	Cryogenic sprays
	Heat guns and blowers
	Sand or bead blasting
	Electrostatic copiers
	Plastics tool handles, tool boxes, work folders, laminated papers
	Plastic syringes, ballpoint pens, insulative support block
	Plexiglas and styrofoam materials
	Latex finger cots
	Paper products

NOTE

Virgin cotton can be a static source at low relative humidities such as below 30 percent.

Table 7-2. Typical Electrostatic Voltages Generated by Personnel

Means of Static Generation	Electrostatic Voltages
	10 to 20 percent relative humidity
Walking across carpet	35,000
Walking over vinyl floor	12,000
Worker moving at bench	6,000
Opening and closing vinyl envelopes used to carry work instructions	7,000
Common plastic bag picked up from bench	20,000
Worker sliding in work chair padded with polyurethane	18,000

7.3.3 ESD Parameters. The voltage potential achieved by human beings or materials is dependent on the total charge (Q) of the person or item, typically between 0.1 and 5 microcoulombs, and his/her material capacitance (C), typically between 100 and 250 picofarads. This voltage (V) is equal to the person's charge divided by the capacitance ($V=Q/C$). This voltage can reach levels as high as 35KV under the right conditions.

7.3.3.1 The discharge of this voltage potential (ESD) and the electrostatic field associated with this potential are what are considered detrimental to today's electrical and electronic

devices. A discharge from human beings or materials to or through an electronic device can possess current values of 1-50A and rise times of less than 20 nanoseconds. The energy associated with this discharge can be expressed in millijoules and most of today's circuits can only withstand a fraction of that amount. Figure 7-1 depicts the magnitude of ESD damage to sensitive electronic devices.

TO 00-25-234

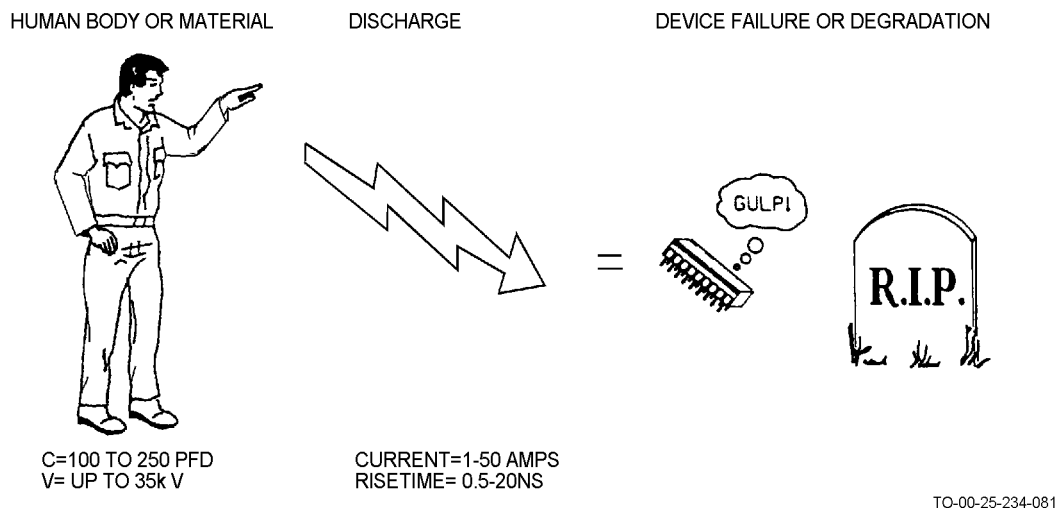

Figure 7-1. Reasons for Device Failure Due to ESD

7.3.3.2 It is important to note that some of today's circuits are sensitive to voltages as low as 25 volts. The threshold of sensitivity or the level of voltage required for a human being to feel a static discharge is approximately 3500 volts. So damage can be done to devices by personnel without them knowing it.

7.3.4 **Failure Mechanisms.** ESD damage to electronic and electrical devices can be caused by voltage or current depending on the composition and construction of the device. This damage can be caused by direct contact or by the electrostatic field associated with charged items.

- a. Voltage-induced failures are predominate in metal oxide semiconductors (MOS) and film type resistors. Dielectric breakdown is the failure mechanism. Dielectric breakdown occurs when the threshold or maximum electric field strength of the dielectric medium is reached and bonded electrons within the medium break free and flow within the dielectric. Figure 7-2 illustrates dielectric failure in a 3N157 MOSFET due to a human body discharge of 4KV.
- b. Current-caused failures primarily affect bipolar devices (diodes, Schottky TTL, input protection circuits, op

amps, etc). Thermal secondary breakdown and metalization melt are the mechanisms. Basically this means that the device cannot dissipate the power associated with an ESD event. The heat generated by the discharge melts device substructures.

7.3.4.1 The smaller the geometries of today's solid state devices the less energy it takes to destroy them.

7.3.5 Failure Types.

7.3.5.1 **Catastrophic.** ESD can cause total (catastrophic) failure of electronic parts, assemblies and equipment.

7.3.5.2 **Intermittent.** ESD can cause intermittent failures or erroneous signals.

7.3.5.3 **Latent.** Items already having been partially damaged by an ESD can check out electrically on the repair/test bench, but fail on the end item when subjected to stresses of wide temperature ranges, mechanical shock, high g-forces, landings or by applying normal operating voltages.

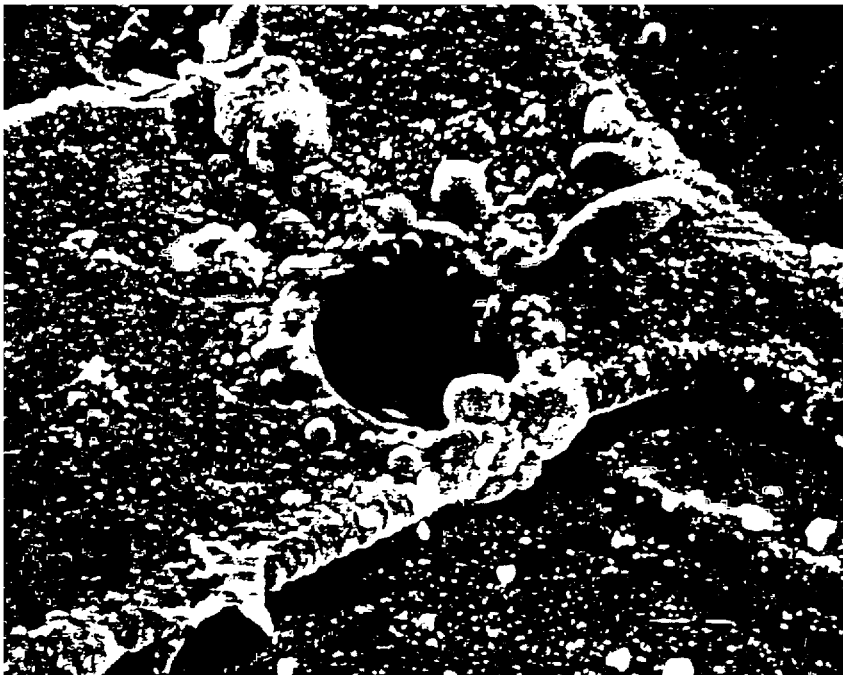

TO-00-25-234-082

Figure 7-2. Dielectric Failure in 3N157 MOSFET at 5000X

7.3.6 Common ESD Misconceptions. Typical misconceptions about ESD and control methods include:

Higher humidity will solve the ESD problem.

Truth: Increasing humidity will only help. It would be more accurate to say that low humidity will aggravate existing ESD problems. (See Paragraph 7.5.5.11).

Components are safe from ESD once they are mounted on PC boards.

Truth: Surprisingly, they can be at least as sensitive to ESD damage. Components on the boards are still current and voltage sensitive even when the leads are attached to the board.

If an electronics assembly passes final test, it means the components on it were handled properly.(3) If an electronics assembly passes final test, it means the components on it were handled properly.

Truth: Not necessarily true. The unit's field failure record, including intermittence, for one to two years after shipment may show the presence of intermittent and latent ESD-caused defects.

The ESD issue can be resolved with the correct hardware and equipment.

Truth: ESD Control hardware and equipment are useless without properly-trained people aware of the ESD hazard and understand how and why the hardware and equipment are used to prevent ESD damage.

7.4 ESD SUSCEPTIBILITY.

7.4.1 Susceptible Items. Numerous discrete electronic parts, assemblies and equipment items are susceptible to ESD damage or degradation when an ESD event occurs or when exposed to electrostatic fields. The system program manager or equipment specialist for the item(s) in question shall utilize direction provided in Paragraph 7.4.1.1 to determine which items are ESD susceptible. A general discussion of what discrete parts and higher level assemblies are ESDS follows. The contents of the following paragraphs shall be used in the absence of other directives or determinations of ESDS items by the system program manager/equipment specialist as specified in Paragraph 7.4.1.1.

7.4.1.1 Discrete Parts. The following discrete parts shall be considered ESDS. Note that the nomenclature given for each Federal Supply Class (FSC) specifies what items within the FSC are ESDS. Any exceptions to this guidance must be verified through actual testing conducted in accordance with

TO 00-25-234

ANSI/ESD S20.20, Annex B per test method 3015 of MIL-STD-883 and provided through the responsible system program manager or equipment specialist.

All microcircuits and integrated circuits in FSC 5962.

Crystal Oscillators and Piezoelectric Crystals in FSC 5955.

Electronic Modules in FSC 5963.

Mini and Microcomputer Devices in FSC 7042.

Thick and thin film resistors, Resistor chips and resistor networks in FSC 5905. (Note: This does not include wire wound or carbon resistors).

Any semiconductor device in FSC 5961 which includes the following: diodes (PN, PIN, Schottky), metal oxide semiconductor field effect transistors (MOSFETS), junction field effect transistors (JFETs), bipolar transistors, thyristors, input protection circuits on discrete MOSFETs and MOS ICs, and microwave devices.

Very High Speed Integrated Circuits (VHSIC), SSI, MSI, LSI, VLSI and ULSI Integrated Circuits.

Optoelectronic devices (LEDs, Phototransistors, Opto Couplers).

Surface Acoustic Wave (SAW) devices.

Operational Amplifiers (OP AMPS).

7.4.1.2 Circuit Boards, Modules and Assemblies. Any circuit board, wiring board, module or assembly containing discrete ESDS parts mentioned in Paragraph 7.4.1.1 above shall be considered ESDS.

7.4.1.3 Any complete system, "Black Box", Line Replaceable Unit (LRU), Shop Replaceable Unit (SRU), Electronic test or repair equipment console/item or end item containing the assemblies or parts mentioned in Paragraph 7.4.1.1 and Paragraph 7.4.1.2 above shall be considered ESDS until the conditions of Paragraph 7.4.2. are satisfied.

7.4.2 When Does ESD Susceptibility Stop. When the items listed in Paragraph 7.4.1. are correctly packaged in accordance with Paragraph 7.5.5.14 they are no longer considered ESDS. That is, they are considered ESDS until the level of assembly or packaging is such that a complete electrostatic shield (Faraday Cage) exists around the item or until which time it can be shown by testing that the ESDS item is protected from static voltages above 16,000 volts. A complete electrostatic shield, or Faraday Cage, is defined as, "An

electrically continuous conductive enclosure which provides electrostatic shielding". For items in Paragraph 7.4.1.1 and Paragraph 7.4.1.2 the "Faraday Cage" might be a closed or sealed static shielding pouch or conductive tote box. Regarding items listed in Paragraph 7.4.3, a complete electrostatic shield may be the chassis or outer case of the assembly (black box) with conductive caps or plugs applied to all electrical connectors. Items in Paragraph 7.4.3, in the absence of conductive connector caps, may be considered in an ESD safe state if strong electric fields (greater than 2000 volts per inch) are kept at least 12 inches from the exposed electrical connectors.

NOTE

ESD connector caps are not required for all applications (reference Paragraph 7.6 Step i.).

7.4.3 ESD Sensitivity Defined. ESD sensitive devices are defined as those devices with failure thresholds between 0 and 16,000 volts (human body model). All discrete parts, circuit boards, modules, assemblies, or other equipment defined in Paragraph 7.4.1, Paragraph 7.4.2, or Paragraph 7.4.3 are considered sensitive to ESD. The Defense Supply Center Columbus (DSCC) has information available for determining level of ESD sensitivity. For FSC 5961 parts, a qualified products database (QPD) is available for MIL-PRF-19500. For FSC 5692 parts, a QPD is available for MIL-PRF-38535. This information is available on the DSCC web site, <http://www.dsccl.dla.mil/>.

NOTE

Note that in the remainder of this chapter (7) of the TO, discrete electronic parts, assemblies, and equipment items will be collectively referred to as "items".

7.5 FRAMEWORK OF ESD CONTROL.

7.5.1 Work Area ESD Control Surveys. ESD Control work area surveys shall be conducted in accordance with this TO of all areas that handle ESDS items. What constitutes a work area shall be determined by the surveyor. It may be defined by the operations being performed, location, etc. The survey establishes the extent of ESD Controls required in each work area. A written report shall be completed after each work area survey to provide a record of the controls required in the work area.

7.5.2 ESD Control Strategies. Two simple rules will substantially reduce the risk of ESD damage to ESDS items.

7.5.2.1 Rule 1: Handle all ESDS items at an approved static control workstation. ESDS items shall always be handled at a static control workstation or a personnel wrist strap utilized in situations where complete workstations are not feasible (i.e. on aircraft or missile maintenance) as de-

scribed in (Paragraph 7.5.4.1). Paragraph 7.7 provides guidance on the selection of a proper static control workstation or personnel wrist strap.

7.5.2.2 Rule 2: Transport and store all ESDS items (both repairable and serviceable) in static shielding (Faraday Cage) and non-charge generating packages or containers. These packages or containers are capable of protecting the inner contents against static fields and discharges. They are also constructed so that the interior surface contacting the packaged item is resistant to the generation of static charge. Paragraph 7.7 provides requirements for selection of the proper package or container for in-house and off-base transportation applications. Both repairable and serviceable ESDS items require protective packaging. Repairables require it to prevent further ESD damage from being done to the remaining operative parts. Paragraph 7.5.5.14 provides the requirements of ESD protective packaging materials. In the case of whole systems containing ESDS items this static shield may be its metallic frame or shell as long as electrical leads to the outside world are properly capped with conductive materials. When conductive ESD connector caps are not required, personnel shall avoid direct contact with the pins of exposed connectors and strong electric fields greater than 2000 volts per inch shall be kept at a distance of 1-foot from these connectors during transport or storage.

7.5.3 Conductive/Static Dissipative/Non-Charge Generating Materials. For the purpose of ESD Control, most protective materials will be either conductive or static dissipative. Packaging materials or containers used for ESD Control are typically as conductive (1 to 9.99×10^5 (999,999) ohms) as possible so that the best "Faraday Cage" properties are obtained. Static Dissipative materials (1.0×10^6 (1,000,000) to 1.0×10^9 (1,000,000,000) ohms) are used for all other products (i.e. work surfaces, garments, footwear, flooring, etc.) so that adequate static drain is accomplished. That is, static drain that is fast enough to remove static charge quickly yet slow enough as to not produce damaging discharge currents. Non-charge generating materials are designed to prevent the generation of static charge but are not adequate for shielding. Conductive and static dissipative materials are available that prevent the generation of charge and to be adequate static shields.

7.5.4 ESD Control Products. ESD Control products are required to implement the rules in Paragraph 7.5.5.2. Precisely which and how many products are needed is determined during the work area ESD Control survey (see Paragraph 7.7). The following paragraphs describe these products in terms of their applications and physical characteristics.

NOTE

Only products qualified through the Air Force ESD Control Technology Center and included in Table 7-3 may be used in Air Force facilities. Use of a substitute item may only be authorized by the Air Force ESD Control Technology Center. Hand tools are not listed in Table 7-3, nor do they require approval by the Air Force ESD Control Technology Center.

7.5.4.1 Static Control Workstations (Reference MIL-PRF-87893). There are four types of static control workstations appropriate for various applications.

- * Permanent Static Control Workstation
- * Static Control Workstation (with cushioned work surface)
- * Static Control Workstation (with rigid work surface)
- * Portable Static Control Workstation

7.5.5 Principle Components. Each type of workstation has three principal components: (1) Static Dissipative Work Surface, (2) Personnel Wrist Strap, and (3) Common Point Ground System (CPGS). Continuous workstation monitors are currently optional depending on the requirements of the work area survey (see Paragraph 7.7). A description of each workstation type is provided below.

7.5.5.1 Permanent Static Control Workstation. This workstation is one in which the static dissipative work surface is built into the workbench itself (i.e. laminated, pressure formed, etc.). Only soft laminates are approved at this time. A personnel wrist strap (adjustable cuff and either 5 ft. or 10 ft. cord) shall be included at this station. The station shall also utilize a common point ground system for ensuring the wrist strap and work surface are tied to the same point electrically prior to grounding. Figure 7-3 shows a conventional permanent static control workstation without the continuous workstation monitor. The Continuous Workstation Monitor (if not previously installed) shall be installed per the manufacturer's instructions provided.

TO 00-25-234

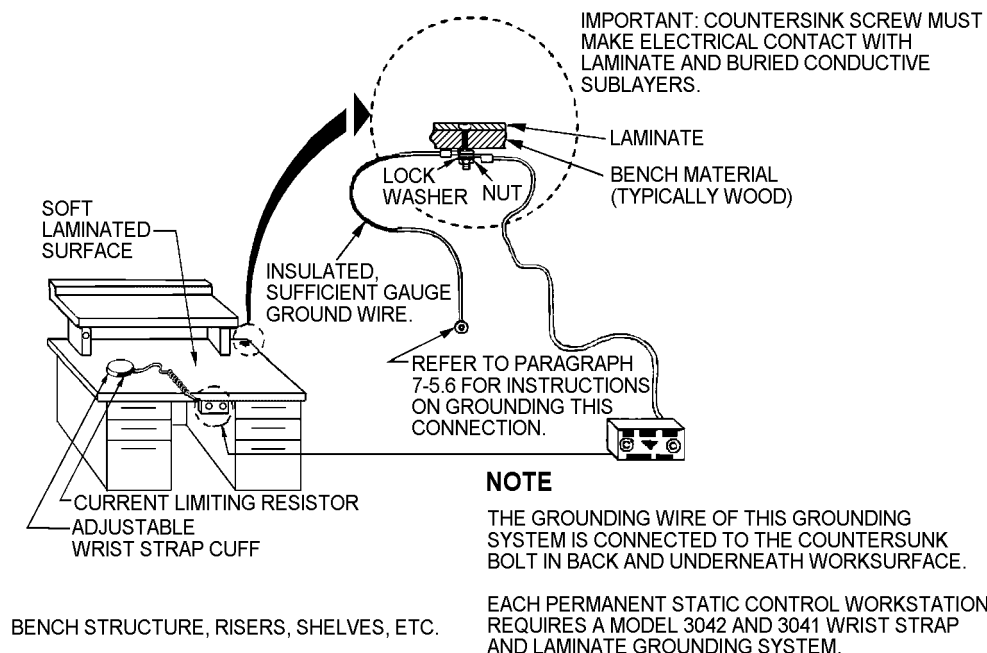

TO-00-25-234-083

Figure 7-3. Permanent Static Control Workstation

7.5.5.1.1 Various features for permanent workstations including drawers, riser shelves and power outlets are available.

7.5.5.1.2 Continuous workstation monitors are included with each of the permanent workstations listed in Table 7-3. The monitor continuously checks the resistance of the workstation, operator, and connections to ensure that all are effectively grounded. The personnel wrist strap that must be used with this monitor is different from the standard wrist strap described earlier in this paragraph. It has a dual conductor cord so that a resistance measurement can be made from the monitor, through the cord to the cuff, through the wearer's wrist, into the cuff again and back to the monitor through the other conductor in the cord. The monitor is also equipped with a remote wrist strap jack. This would be used instead of the dual banana system shown in Figure 7-3 whenever a continuous workstation monitor is used. The continuous monitor does however have an additional grounded banana jack to accommodate standard, single conductor wrist straps. Note however that the banana jack is not monitored and any wrist strap connected there shall be tested in accordance with Paragraph 7.8.

NOTE

The dual conductor wrist strap cord and cuff can only be used when workstation monitors are incorporated. They will not work with the conventional banana jack shown in Figure 7-3.

7.5.5.1.3 Periodic testing of the worksurface and inner surfaces of cabinets and drawers within a permanent workstation is required in accordance with Paragraph 7.6. Testing shall be conducted in accordance with Paragraph 7.8. Paragraph 7.5.6. provides directions for grounding permanent workstations. Workstations that utilize a continuous monitor require an additional ground connection (for the monitor itself). It is the same electrically as the one outlined for the workstation in Paragraph 7.5.6.

7.5.5.2 Static Control Workstation (with cushioned work surface). This workstation consists of a cushioned, four-foot by two-foot static dissipative work surface, an adjustable wrist strap cuff and 5 foot cord and a common point ground system. It can be installed on any work bench or table and typically is used in applications where work surface cushioning is desired. Figure 7-4 shows a typical workstation with the cushioned workstation on an existing work bench. A NSN has been established for a 40 ft. runner of the cushioned work surface material (see Table 7-3). The runner can be cut to fit uniquely shaped work bench surfaces. Note that if this is done, the common point ground system and wrist strap must still be attached to the cut work surface so that the proper workstation orientation is maintained. Grounding of the workstation shall be done in accordance with Paragraph 7.5.6.

- * INSURE THAT MATTING DOES NOT EXTEND OVER MORE THAN ONE BENCH. USE INDIVIDUAL MATS FOR EACH WORK BENCH. DO NOT CONNECT DIFFERENT MATS TOGETHER IN SERIES.

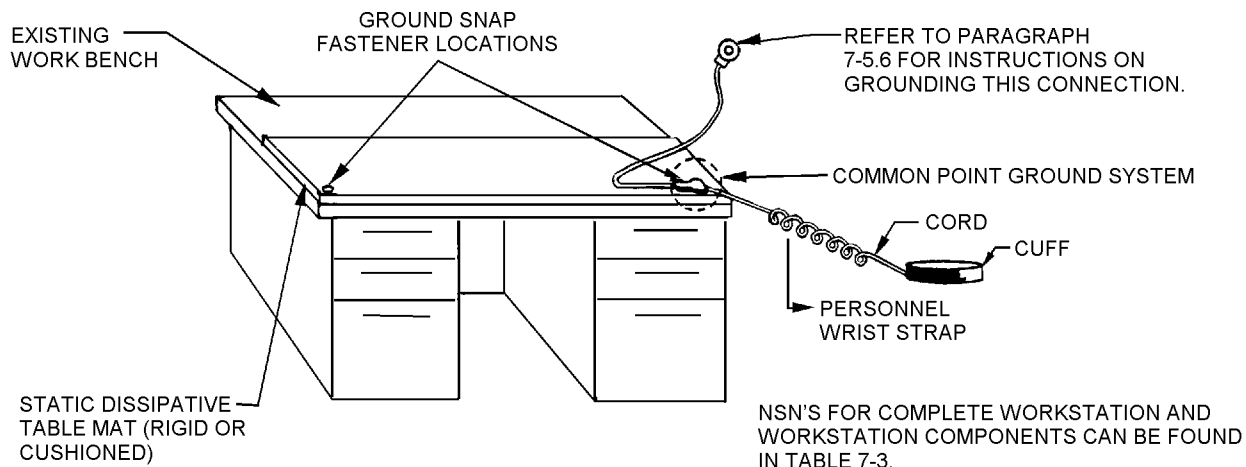

TO-00-25-234-084

Figure 7-4. Static Control Workstation (work cushioned or rigid work surface on an existing work bench)

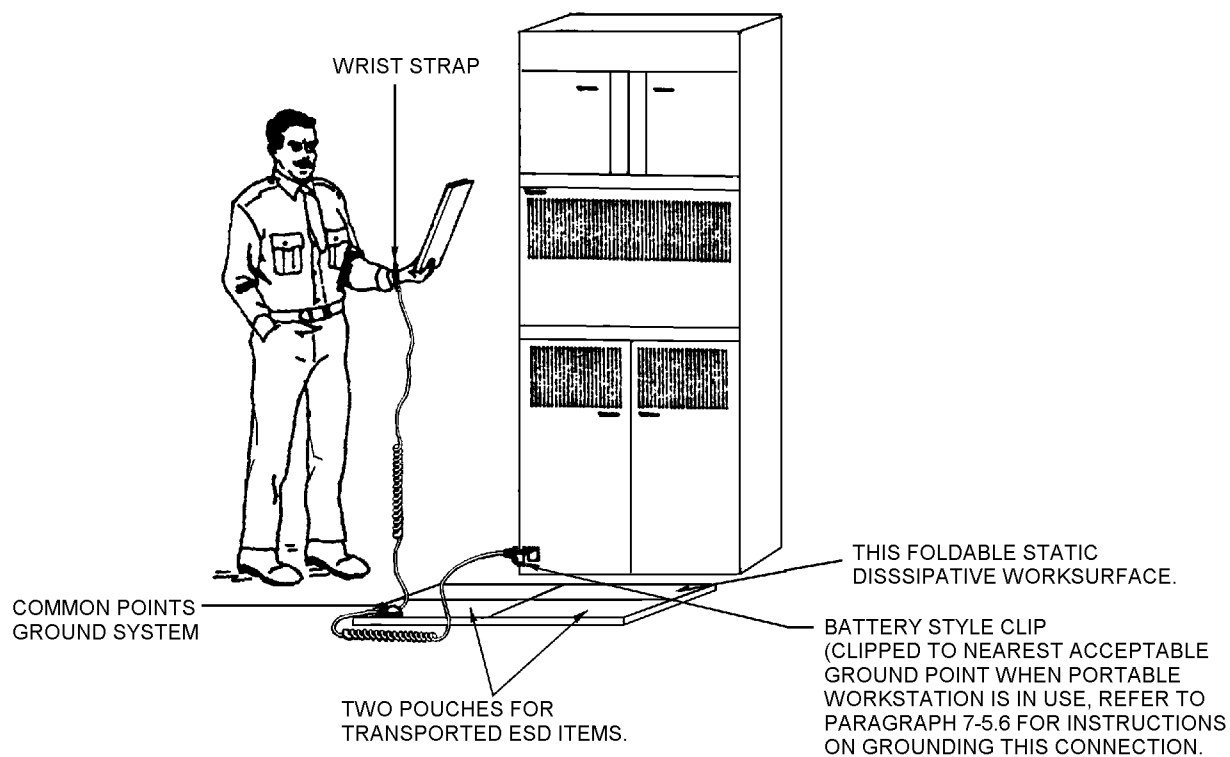

TO-00-25-234-085

Figure 7-5. Portable Static Control Workstation

TO 00-25-234

7.5.5.2.1 Periodic testing of the worksurface and the runner material is required in accordance with Paragraph 7.6 to ensure they retain their ESD Control properties over time. Testing shall be conducted in accordance with Paragraph 7.8.

7.5.5.2.2 Continuous workstation monitors can also be utilized at these workstations if required by the work area ESD Control survey (see Paragraph 7.7). As mentioned earlier in this paragraph, a special dual conductor wrist strap cord and cuff must be used for the monitor to be effective. Installation instructions are provided with the monitor.

7.5.5.3 Static Control Workstation (with rigid work surface). This workstation consists of a rigid, four-foot by two-foot static dissipative work surface, adjustable wrist strap cuff and 5 ft. cord, and a common point ground system. It can be installed on any existing work bench or table and can be used in clean room operations because of its resistance to abrasion. It can also be used in operations where large, heavy objects are handled which could damage the cushioned work surface. Moreover, the work surface can be physically modified to meet uniquely sized surfaces. Figure 7-4 shows a typical workstation with rigid worksurface on an existing work bench. Grounding of the workstation shall be done in accordance with Paragraph 7.5.6.

7.5.5.3.1 Periodic testing of the worksurface is required in accordance with Paragraph 7.6 to ensure it retains its ESD Control properties over time. Testing shall be conducted in accordance with Paragraph 7.8.

7.5.5.3.2 Continuous workstation monitors can also be utilized at these workstations if required by the work area ESD Control survey (see Paragraph 7.7). As mentioned earlier in this paragraph, a special dual conductor wrist strap cord and cuff must be used for the monitor to be effective. Installation instructions are provided with the monitor.

7.5.5.4 Portable Static Control Workstation. This workstation is a kit containing a thin, foldable, (approximately 22 inch by 24 inch) static dissipative work surface, an adjustable wrist strap cuff, a 10 ft. cord, and a common point ground system. It shall be used during remote maintenance or handling of ESDS items where the larger static control workstations mentioned in Paragraph 7.5.5.1, Paragraph 7.5.5.2 and Paragraph 7.5.5.3 cannot be installed or utilized; or when determined by the ESD representative to be the most appropriate type of ESD workstation for a particular operation. Grounding of the portable workstation shall be done in accordance with Paragraph 7.5.7.3. Figure 7-5 shows a typical portable workstation.

7.5.5.4.1 Periodic testing of the work surface is required in accordance with Paragraph 7.6 to ensure it retains its ESD Control properties over time. Testing shall be conducted in accordance with Paragraph 7.8.

7.5.5.5 Personnel Wrist Strap. The personnel wrist strap is the single most important item for effective static control. It effectively drains static charge from the individual wearing it. Personnel handling ESDS items outside of their protective static shielding container or packaging shall wear a wrist strap. It consists of two components: (1) a woven or knitted elastic fabric cuff, and (2) a 5 or 10 ft. coiled, insulated and flexible cord. The cuff shall be worn snug to the wrist and shall be adjusted when necessary to ensure a snug fit.

WARNING

The personnel wrist strap shall not be worn when working on energized parts, assemblies and equipment. This requirement does not apply in situations where the powered equipment is operated normally (e.g., not opened up for maintenance, etc.), and no contact with live voltage and/or current is possible. In situations where the manufacturer recommends wearing a wrist strap on energized equipment where contact with live voltage/current is possible, the wrist strap may be worn if approval is granted from the local safety office.

7.5.5.5.1 Note that the wrist strap cuff and cord to be used with continuous workstation monitors described earlier vary from the standard NSN-listed wrist straps. As explained in Paragraph 7.5.5.1, they have two wires in them and are only available in specific sizes; small, medium and large. They are not adjustable. They also have separate part numbers which are listed in Table 7-3.

7.5.5.5.2 One megohm resistors are built into the cords of both wrist strap styles at the point where they attach to the wrist strap cuff. Periodic testing of the wrist strap is required per Paragraph 7.6 and shall be tested in accordance with Paragraph 7.8.

7.5.5.6 Common Point Ground Systems (CPGS).

NOTE

The two wire wrist strap cord and cuff can only be used when continuous workstation monitors are used.

A CPGS is required at any static control workstation that does not utilize a continuous workstation monitor. The CPGS ensures that the station's personnel wrist strap and the static dissipative work surface are connected physically and electrically at the same point.

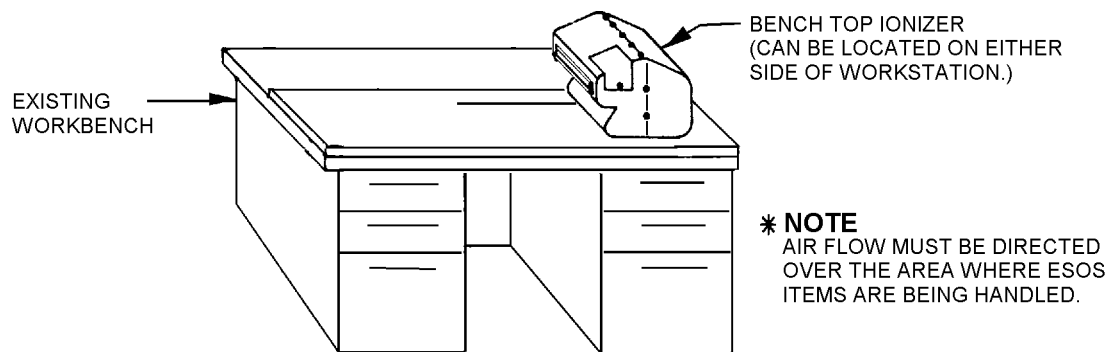

TO-00-25-234-086

Figure 7-6. Bench Top Ionizer Positioning

7.5.5.6.1 The CPGS has a single ground line (15 ft.) that requires attachment to a verified ground termination point (Reference Paragraph 7.5.6). Figure 7-4 and Figure 7-5 show the CPGS orientation as installed with the different workstations. There are two CPGS orientations also. One is used with the workstations outlined in Paragraph 7.5.5.3 and Paragraph 7.5.5.4 and has a standard ring termination. The other is used with a portable workstation and has a clamp-type termination.

7.5.5.6.2 The common point ground concept varies slightly when continuous workstation monitors are used. The monitor continuously monitors the resistance of the work surface ground path as well as the wrist strap cuff and cord and these functions require separate circuits. Because of this, the wrist strap and work surface are not physically connected to a common point as is the case with workstations without the monitor.

7.5.5.7 **Bench Top Ionizers.** Bench Top Ionizers are used to neutralize static charge on job essential, non-conductive or ungrounded-conductive items used at the ESD Control workstation. They are not required at every ESD control workstation. They are required at workstations handling the devices and doing the work specified in Paragraph 7.7.4.7.2. Workstations utilizing bench top ionizers shall position them as shown in Figure 7-6.

7.5.5.7.1 There are two primary types of bench top ionizers. Those that generate ions through alpha emissions and those that generate ions electrically. Both types are considered satisfactory for use if required by the work area ESD Control survey. Both also require some degree of maintenance and/or accounting.

7.5.5.7.2 Ionizers that ionize through alpha emissions have two major assemblies. (1) A blower/housing for projecting the ions across the work surface and (2) an alpha emitting ionizing bar, for generating positive and negative ions. The blower is requisitioned through normal procedures, the model number can be found in Table 7-3. The ionizing bar is obtained through a lease contract and must be obtained locally.

In addition, a USAF Radioactive Material Permit in accordance with AFI 40-201 and TO 00-110N-3 is required through the USAF Radioisotope Committee (HQ AFOMA/SGOR) at Brooks AFB, Texas. The permit must be acquired prior to receipt of the ionizing bars. Strict accountability and periodic swipe testing is required for the ionizing sources. The base/facility Radiation Safety Officer (RSO) can assist in the accounting, swipe testing and the permit/acquisition effort. Model numbers for the ionizing bars can be found in Table 7-3.

WARNING

Ionizers utilizing alpha emitting ionizing sources should be used with strict adherence to manufacturers safety guidelines and procedures. Use bench top ionizers only in situations outlined in Paragraph 7.7.4.7.2.

7.5.5.7.3 Ionizers that generate ions electrically are also acceptable for use if required in the work area ESD Control survey. They vary from the alpha emitting ionizers in that they require periodic testing to verify their functionality. As a minimum, electrical ionizers shall be checked quarterly, by conducting discharge time and offset voltage tests. Periodic testing of ionizers is required in accordance with Paragraph 7.6 and shall be tested in accordance with Paragraph 7.8.

7.5.5.8 **Static Dissipative Gloves and Finger Cots.** Operations which involve the handling of ESDS items and require gloves or finger cots to control contamination from the hands shall utilize static dissipative gloves. The work area survey Paragraph 7.7.4.7.9 will dictate whether gloves are necessary.

7.5.5.9 **Static Dissipative Flooring System.** A static dissipative flooring system is a static control requirement when specified in the work area survey Paragraph 7.7.4.7.5. A floor system includes static dissipative flooring, shoes and seating designed to remove static charge from personnel when han-

TO 00-25-234

dling ESDS items. Independently, each does not provide adequate ESD Control protection. They must be used simultaneously. Information regarding static dissipative flooring, shoes and seating are provided in the ensuing paragraphs.

7.5.5.9.1 Static Dissipative Flooring. Static dissipative flooring is a static control requirement when specified in the work area survey. Qualified sources of flooring materials are not listed in this TO because styles and techniques will vary from installation to installation. A periodic test method for installed flooring is provided in Paragraph 7.8 and shall be used in accordance with Paragraph 7.6. A specification for static dissipative flooring has been developed at the Air Force ESD Technology Center and shall be used when qualifying a floor prior to installation. Grounding of static dissipative flooring shall be done at least one point per 10,000 sq. ft. of installed floor or part thereof with a minimum of two grounding points per floor. Use only manufacturer suggested ESD cleaners and conditioners, following prescribed application procedures. If there are no manufacturer suggested ESD cleaners or conditioners, clean the floor using mild soap and water, ensuring no residue remains. Never apply standard floor wax to static dissipative flooring. No waxes or coatings shall be applied to the flooring at any time.

7.5.5.9.2 Static Dissipative Shoes: Static dissipative shoes are a static control requirement when specified in the work area ESD Control survey. Qualified sources of static dissipative shoes are not listed in Table 7-3, due to constantly changing styles and similar part numbers used by multiple manufacturers. Contact the ESD Control Technology Center (reference Paragraph 7.1) for a listing of qualified ESD footwear. Periodic testing of shoes per Paragraph 7.6 is required to ensure continued ESD Control performance. The test procedure is provided in Paragraph 7.8.

7.5.5.9.3 Static Dissipative Seating: Static dissipative seating is a static control requirement when specified in the work area ESD Control survey. Periodic testing of seating per Paragraph 7.6 is required to ensure continued ESD Control performance. The test procedure is provided in Paragraph 7.8.

7.5.5.10 Grounded Electrical Tools and Equipment. Electrical equipment required to perform the work being done at the ESD Control workstation shall be properly grounded. Specifically, soldering irons, solder pots, or flow soldering and solder sucking equipment shall be hand grounded and the transformer isolated from the power line. The specific solder grounding techniques specified in TO 00-25-259 shall be utilized. Any other electrical tool or electrical equipment item that comes in contact with ESDS items shall also be grounded. This means that all exposed metallic surfaces of these equipment items shall be connected electrically via a grounded plug to the equipment items power system or other hard ground. This ensures that no potential difference (voltage) exists between ESDS items and equipment used at the workstation.

7.5.5.11 Relative Humidity. Humid air helps to dissipate electrostatic charges by keeping surfaces moist. This increases surface conductivity and minimizes the chance for charge generation. In many cases though, the decreased static levels made possible by higher humidity are still large enough to destroy or degrade ESDS items. The requirement for the use of higher humidity levels for static control is governed by the work area static control survey and Paragraph 7.7.4.6.3.

7.5.5.12 Computer Keyboard Ground Strips. Computer keyboard ground strips are an ESD control concern for older keyboard systems. The manufacturer is phasing out the ground strips because there hasn't been the same ESD control concern with newer (modern) keyboards as with older units.

7.5.5.12.1 The strip easily attaches to the keyboard, is easily grounded and is used in lieu of a personnel wrist strap which is not feasible in computerized work areas. The requirement for use of these ground strips is defined by the work area ESD Control survey and Paragraph 7.7.4.7.10. Figure 7-7 shows ground strip installation procedures.

7.5.5.13 ESD Control Product and Ground Integrity Test Equipment.



Static fields associated with some computer CRT's are substantial and should be kept away from ESDS items.

The specifications for the various ESD Control products referenced in this section were developed to ensure the military receives and continues to use quality and reliable ESD Control products. Verification of specification requirements is done with the following basic test equipment. However, some specifications require test equipment not available in many field or depot maintenance shops. The following equipment shall be obtained as required to verify that the electrical integrity of the ESD control products is maintained throughout their usable lives. Part numbers and NSNs for these equipment items can be found in Table 7-3. These test equipment items include:

7.5.5.13.1 Electrostatic Field Meter. This device detects the presence of electrostatic fields emanating from a charged object. It is basically a tool for verifying whether or not electrostatic fields exist in the work place. It should not be used to make precise measurements. The ability of a material to generate charge can be roughly seen with the meter.



STATIC FIELDS ASSOCIATED WITH SOME COMPUTER CRT'S ARE SUBSTANTIAL AND SHOULD BE KEPT AWAY FROM ESDS ITEMS.

COMPUTER KEYBOARD TOUCH STRIP INSTALLATION PROCEDURES

TOUCH STRIP GROUND CORD:

- (1) TUCK GROUND CORD UNDER KEYBOARD AND COMPUTER.
- (2) CONNECT GROUND CORD TO CHASSIS SCREW ON REAR OF COMPUTER.
- (3) ELECTRICALLY CHECK TO ENSURE CHASSIS SCREW HAS ELECTRICAL CONTINUITY TO THE ROUND PIN (GROUNDING CONDUCTOR) OF THE COMPUTER'S POWER PLUG.

REFER TO PARAGRAPH 7-5.6 FOR INSTRUCTIONS VERIFYING THE GROUND INTEGRITY OF THE ELECTRICAL OUTLET USE TO POWER THE COMPUTER.

TOUCH STRIP INSTALLATION INSTRUCTIONS:

- (1) DETERMINE PROPER LOCATION ON KEYBOARD. OPERATOR'S HANDS WHEN AT REST SHOULD TOUCH THE STRIP NATURALLY. (SEE FIGURE A)
- (2) REMOVE LINER AND ADHERE STRIP TO KEYBOARD. (SEE FIGURE B)
- (3) CONNECT GROUND CORD EYELET TO A CHASSIS SCREW ON THE BACK OF THE MAIN COMPUTER. ELECTRICALLY ENSURE THE CHASSIS SCREW HAS ELECTRICAL CONTINUITY TO THE ROUND PIN OF THE COMPUTER'S POWER PLUG.

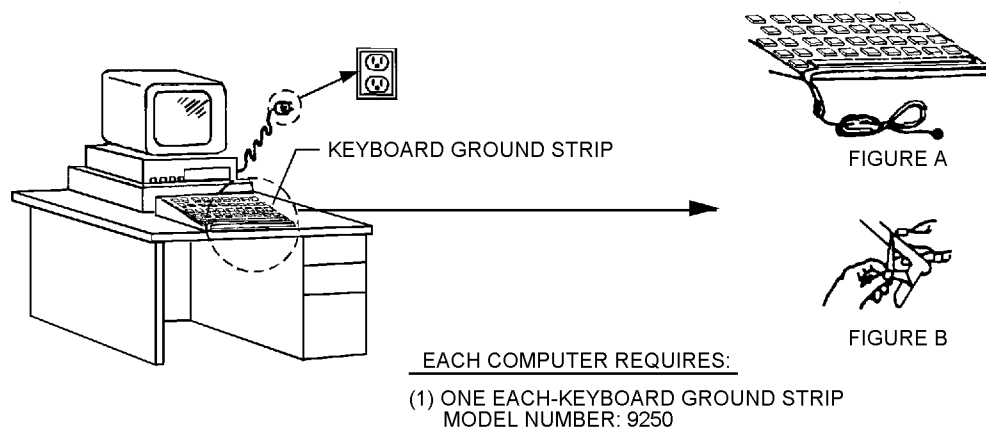

TO-00-25-234-087

Figure 7-7. First Touch Installation Procedures

7.5.5.13.2 Wrist Strap Tester. This device will allow the operator to check the integrity of his/her wrist strap cuff and cord. The tester allows for electrical continuity and resistance checks of both the wrist strap cord alone and of the entire wrist strap system while the operator is wearing it. It ensures that the resistance for both situations is between 1 and 10 megohms.

7.5.5.13.3 Variable Voltage Megohmmeter. This instrument will allow for measurement of static dissipative work surfaces, floors, shoes and the resistance of any other static control material that requires resistances in the one megohm to 1000 megohm range. One hundred (100) volts is the standard test voltage for most ESD control materials that require periodic testing per Paragraph 7.8.

7.5.5.13.4 Resistance Test Electrodes. Two, 5 lb. (+/1 oz.), 2.5 inch (± 0.062 in.) diameter flat surfaced electrodes are required to make the resistance measurements with the megohmmeter mentioned in Paragraph 7.5.5.13.3. The electrodes are prepared by placing a piece of heavy tin foil on a flat, hard and smooth surface. On top of the foil place a 2.5 inch diameter disk of 0.25 inch thick rubber that has a hardness of 50 ± 10 as measured on a Shore type A Durometer which is described in Test Method "D" 2240 (Test Method For Rubber Property-Durometer Hardness). Place the electrode on top of the rubber pad, draw the foil up around the rubber pad and electrode. Secure the foil with a hose clamp. Repeat procedures for the second electrode. Electrodes that have conductive rubber do not need the tin foil, but the rubber pads need to be cleaned with 70% isopropyl alcohol.

TO 00-25-234

Conductive rubber electrode pads (2.50 inches diam. x 0.25 inch thick) can be used with the electrodes in lieu of the aluminum foil/rubber combination specified for the construction of the electrodes.

7.5.5.13.5 Megohmmeter Test Kit. The kit contains the variable voltage megohmmeter and the 5 lb. electrodes referenced above.

7.5.5.13.6 Ohmmeter. The ohmmeter is used to check the integrity of grounding conductors and bonding devices for ESD control workstations, cabinets and floors as well as solder guns or iron tip continuity. (see Paragraph 7.5.6 for details).

7.5.5.13.7 Ground Impedance and Utility Wiring Verification Meter. This meter is required for measuring the wiring accuracy in electrical systems and assuring that ground conductors (third wire) in power systems are effective for static drainage and safe for personnel usage. The meter is capable of analyzing the hot, neutral and equipment ground conductors of an electrical system. It will measure the impedance between neutral and the equipment ground conductors to verify the integrity of the ground point used in grounding static control workstations, cabinets or floors. Paragraph 7.5.6 provides details on the use of this meter.

7.5.5.13.8 Charged Plate Monitor. A charged plate monitor is used to verify the performance of bench top ionizers by measuring charge decay times and offset voltages. It shall have a 6 in. x 6 in. conductive plate (20 pf capacitance maximum) for a sensor. The monitor shall be capable of measuring decay times from initial plate voltages of ± 1000 volts to ± 100 volts respectively.

7.5.5.13.9 Air Velocity Meter. An air velocity flow meter is required to measure the speed of the air flowing from bench top ionizers when conducting periodic performance tests. The meter shall be capable of measuring velocities of at least 550 Ft/Min (FPM) at a distance of 6 inches from the ionizer (see Paragraph 7.8.6).

7.5.5.13.10 Consolidated Test Kits. Consolidated Test Kits are available and include the following equipment:

Kit A: Field meter, wrist strap tester, megohmmeter, 2 test electrodes, ground impedance verification meter, charge plate monitor and air velocity meter.

Kit B: Field meter, wrist strap tester, megohmmeter, 2 test electrodes and ground impedance verification meter.

Kit A is for areas where air ionizers must be used and tested. Kit B is available for areas without the requirement for air ionizers. These kits provide bases or organizations with multiple ESD controlled areas a means of sharing this specialized test equipment. The consolidated test kit is also a more cost efficient option for organizations required to initially purchase most or all of the prior mentioned test equipment.

7.5.5.14 Packaging Materials - ESD protective packaging is required anytime an ESDS item is stored or transported (reference MIL-STD-2073-1 and MIL-HDBK-773). Static shielding and non-charge generating materials shall be used. MIL-PRF-81705, Type I is a shielding barrier material made to withstand many phenomenon outside of ESD. Type II, removed from specification, is a non-charge generating material that may continue to be used in-house until supplies are exhausted. Type III is a non-charge generating and static shielding material. The packaging materials required and conditions for their use with ESDS items are described in the following paragraphs.

7.5.5.14.1 Discrete ESDS Parts (see Paragraph 7.4.1.1) shall be packaged as follows:

- a. Discrete parts received from the manufacturer, or discrete parts transported from base to base (to/from a contractor's facility or cross country in any way), or discrete parts sent to long term storage shall be packaged as follows:
 - (1) The initial wrap shall be a non-charge generating material conforming to MIL-PRF-81705 Type III, or bags conforming to MIL-DTL-117, Type II, Class H, Style 2, or cushioned in material conforming to A-A-3129, Type I, Grade B or PPP-C-795, Class 2 or PPP-C-1797, Type II, to prevent bag puncture. Reclosable cushioned pouches conforming to MIL-DTL-81997, Type I or II, may be used in lieu of initial wrap or cushioning.
 - (2) The wrapped/cushioned item shall then be placed in a heat sealed bag conforming to MIL-DTL-117, Type I, Class F, Style 1 (MIL-PRF-81705, Type I barrier material).

NOTE

No plastic or insulative/non-conductive materials shall be used as the item wrap, nor shall they be used inside the MIL-DTL-117 (MIL-PRF-81705, Type I barrier material) bag. In addition, discrete part lead holders made of plastics or non-conductive materials shall not be used.

b. Discrete parts transported or stored locally (in-house) shall be packaged by one of the following options:

- (1) In the original manufacturers packaging materials if not opened. If opened, but the item was not used, Seal the bag by folding over the open end of the bag and using non-charge generating tape or an ESD attention label (Figure 7-11) to hold the bag closed. Zipper closure bags are considered sealed when the zipper is closed.
- (2) Packaged per Paragraph 7.5.5.14.1, except that sealing may be accomplished by folding over the open end of the bag and using non-charge generating tape or an ESD attention label (Figure 7-11) to hold the bag closed. Zipper closure bags are considered sealed when the zipper is closed.
- (3) Placed in a sealed MIL-DTL-117, Type II, Class H, Style 2 (MIL-PRF-81705, Type III) shielding bag or sealed cushioned pouch per MIL-DTL-81997, Type I. Sealing may be accomplished by folding over the open end of the bag and using non-charge generating tape or an ESD attention label (Figure 7-11) to hold the bag closed. Zipper closure bags are considered sealed when the zipper is closed.

NOTE

The item may be initially cushioned Figure 7-11 in material conforming to A-A-3129, Type I, Grade B or PPP-C-795, Class 2 or PPP-C-1797, Type II, to prevent bag puncture.

- (4) Discrete parts/IC's stored locally outside of ESD control packaging or conductive tote boxes may be stored in a properly grounded storage cabinet equipped with conductive parts bins.
- (5) Discrete parts/IC's stored locally that have all leads shunted together through use of ESD Control conductive foam or wire are generally considered non-sensitive. As such, these items may be stored locally outside of ESD control packaging or ESD control storage containers. Generally this is the least preferred storage option and should be avoided if the parts are intended for mission equipment.

7.5.5.14.2 Circuit Boards, wiring boards, modules (see Step a) shall be packaged in one of the following manners:

- a. If the circuit boards are bare items and transported or stored locally (in-house), they shall be packaged by one of these methods:

NOTE

For all four options, the shielding pouch/bag shall be sealed by folding over the open end of the bag and using non-charge generating tape or an ESD attention label (Figure 7-11) to hold the bag closed when ESD items are inside. Zipper closure bags are considered sealed when the zipper is closed.

- (1) In a static shielding pouch/bag conforming to MIL-PRF-81705, Type III.
 - (2) Placed in a MIL-PRF-81705, Type II material, then placed in a MIL-PRF-81705, Type I pouch/bag.
 - (3) In a pouch/bag with verifiable MIL-PRF-81705, Type II inner properties (non-charge generating) and MIL-PRF-81705, Type I or III outer properties (static shielding). This bag is usually custom made.
 - (4) In the original manufacturer's packaging materials if not opened. If opened, but not used, reseal the bag.
- b. If the circuit boards or modules are bare items with paperwork that are to be transported or stored locally (in-house), they shall be packaged the same as bare items with these additional requirements:

NOTE

For all three options, the shielding pouch/bag shall be sealed by folding over the open end of the bag and using non-charge generating tape or an ESD attention label (figure 7-11) to hold the bag closed when ESD items are inside. Zipper closure bags are considered sealed when the zipper is closed.

- (1) When using method a, an additional outer bag/pouch made of MIL-PRF-81705, Type II or III material is required. Paperwork shall be placed between the two bags.
- (2) When using method b, paperwork shall be placed in a non-charge generating pouch adhered to the outside of the Type I pouch/bag.

- (3) When using method c, non-charge generating pocket is required on the outside of the pouch/bag to hold the paperwork.

WARNING

There are non-charge generating tapes commercially available. These items are listed in Table 7-3. These tapes generate minimal charge when pulled from the spool and can be used to seal ESD bags. Charge generating tapes (i.e. masking, scotch, duct, etc.) shall not be used to seal or mark the bags mentioned above. Charges generated may be substantial and damage ESDS items. Additionally, staples shall not be used to seal/close these bags.

- c. Cushioning Option (circuit boards, wiring boards, modules) - Cushioning can be achieved by utilizing a cushioned pouch conforming to MIL-P-81997, Type I or II, or wrapped in cushioning material conforming to PPP-C-1842, Type III, Style A or B (A-A-3129, Type I, Grade B), or PPP-C-795, Class 2, or PPP-C-1752, Type VII, Class 1, Grade B (A-A-59135 or A-A-59136, Class 1, Grade B), or PPP-C-1797, Type II to prevent bag puncture and provide adequate protective cushioning for each circuit board or module being transported or stored. Note, these cushioning alternatives provide the non-charge generating characteristics of a MIL-PRF-81705, Type II material only. The cushioning requirement is optional and is dependent on local policy and the fragility of the item(s). If cushioning is used, ensure that the packaging configurations specified in Step a and Step b are maintained.

CAUTION

Some MIL-PRF-81705, Type II and Type III materials may introduce corrosive or solderability problems to solder coatings associated with circuit boards, wiring boards and modules.

- d. All items, both reparable and serviceable, (i.e. circuit boards, wiring boards and modules) being transported from base to base, to/from a contractor's facility or cross country in any way shall be packaged in accordance with MILSTD-2073-1. The item may be packaged as outlined in Step a and Step b, with an additional MIL-PRF-81705, Type I pouch or bag placed around the original packaging materials if the Type I material isn't already the outermost package (as received from the repair/test facility). Heat seal the Type I bag in accordance with MIL-STD-2073-1. The Type I material provides a barrier against many different destructive outside forces other than ESD that can be encountered during transit. In most cases, the packaging developed by the prime ALC will require the packaged item to be placed in a Fast Pack container con-

forming to PPP-B-1672. When placed in the Fast Pack container, the item is afforded adequate physical shock protection for shipment.

7.5.5.14.3 Uniquely Shaped or Fragile Assemblies With Exposed ESDS Parts. These kinds of items basically are any assembly other than circuit boards, wiring boards or modules that have exposed ESDS parts attached. The packaging options outlined in Paragraph 7.5.5.14.2 for circuit boards, wiring boards or modules are acceptable for these items if they are rigid/stable enough to be transported or stored in pouch/bag materials without fear of damage to the item. If the item is too fragile for transport in bags or pouches, then lidded conductive tote boxes with non-corrosive conductive foam interiors shall be used. The foam can be cut to conform to the shape of the item being transported. Ensure that when using cut, conductive foam, that it has been vacuumed and cleaned to remove all loose conductive particles generated by the cutting process. The conductive tote box shall have a conductive lid to ensure total static shielding capabilities. Tote boxes must conform to static shielding requirements similar to those required of static shielding bags/pouches. These techniques apply only to in-house transit (i.e. from repair bench to repair bench, repair to test, organization to organization) of these items. Distribution or packaging organizations receiving items from the repair/test facility for shipment off base, must remove the item from the tote box and package it per the required packaging data developed by the prime ALC (i.e. 0013). This must be done at an ESD Control workstation. The discarded conductive tote box and foam must be returned to the original user.

7.5.5.14.3.1 There will be instances when multiple ESDS items will need to be transported in a single tote box. The same tote boxes listed in Table 7-3 can be used for these circumstances. Again this method is acceptable only for in-house transit of ESDS items. Packaging or distribution organizations shall ship these items off base individually packaged per the required packaging data developed by the prime ALC (i.e. 0013).

7.5.5.14.3.2 There will be situations where these types of assemblies will require transport in and out of clean areas. Different containers are therefore necessary to minimize contamination effects. Part Numbers for static shielding containers that minimize contamination effects are also listed in Table 7-3. Lids are also required for these containers and are listed in Table 7-3. Part numbers for smaller, hinged containers made of the same material are listed in Table 7-3.

7.5.5.14.4 Complete Systems, "Black Boxes", LRUs, SRUs, Test/Repair Equipment items or any end item (see Paragraph 7.4.1.3) The chassis or frame of these items, if made of a metal or conductive material, will act as a "Faraday Cage" or electrostatic shield against static fields or discharges to the item. The connectors or plugs on these items used to apply power or send information to/from the inner circuitry represent a "hole" in the "Faraday Cage" and provides a path by which an ESD pulse can travel, and shall be covered with a conductive cap/plug to complete the faraday

cage. In addition, when applicable, any cable that remains attached to an ESDS item must be capped at the detached end of the cable. Also, when “black boxes” are removed from the next higher assembly (e.g., guidance system, aircraft, missile, etc.), all disconnected cables must be capped at the detached end of the cable if the opposite end of the cable is attached to an ESDS item. This applies to cables that remain with the ESDS item being removed from the next higher assembly as well as those cables that remain attached to other ESDS items within the next higher assembly. Be aware that some test equipment items such as oscilloscope amplifiers or system testers have probe detector rings at the base of their BNC connectors. Conductive caps will short out the ring. Caps containing a shallower depth shall be used to prevent shorting. Screw-on metal caps are used to complete the “Faraday Cage” around the ESDS inner circuitry. Conductive caps or plugs shall be used when no screw-on metal caps exist to cover these connectors and complete the “Faraday Cage”. Various sizes are listed in Table 7-3. In addition, a thermo formable sheet material made of conductive material is included in Table 7-3 to make unique-sized caps that are not found in Table 7-3. Custom made uniquely sized caps are also available and listed in Table 7-3. Call the Air Force ESD Control Technology Center for more information.

NOTE

ESD connector caps are not required for all applications (reference Paragraph 7.6Step i).

7.5.5.15 Marking. To ensure that personnel handling ESDS items are aware of the items’ sensitivity to ESD, proper ESD marking procedures shall be implemented. ESD marking procedures shall be utilized on all ESDS items, procedural documentation, ESD packaging materials and on ESDS item storage cabinets and bins. Many of the specified labels do not have NSNs or part numbers although they are listed in Table 7-3. Organizations should contact the base Publications Distribution Office (PDO) or local businesses to have these labels made in the specified sizes. Color schemes for each label are black letters or symbols against a yellow background. NSNs or part numbers for each label shall be added to the table as they become available. Marking requirements are as follows:

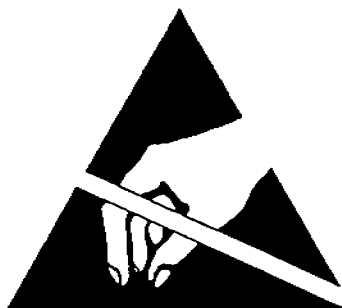

TO-00-25-234-088

Figure 7-8. MIL-STD-1285 Symbol

7.5.5.15.1 Marking of ESDS Items (Hardware). ESDS items and assemblies containing ESDS items outlined in Paragraph 7.4.1 shall be marked on an exterior surface with the MIL-STD-1285 sensitive device symbol shown in Figure 7-8. Marking of all items listed in Paragraph 7.4.1.1 and Paragraph 7.4.1.2 of this TO is dependent on the space available on the item itself and whether such markings are tolerable and do not hinder the operation of the item. If a MIL-STD-1285 symbol cannot be placed on the ESDS item, the packaging used for transport of the item must have the appropriate marking in accordance with Paragraph 7.5.5.15.3, or the storage cabinet or parts bin for the item must be marked in accordance with Paragraph 7.5.5.15.4.

7.5.5.15.2 Marking ESDS Items That Require No Further Packaging. The items specified as ESDS in Paragraph 7.4.1.3 and packaged in accordance with Paragraph 7.5.5.14.4 require no further packaging but often are put into or wrapped

with additional static shielding or non-charge generating materials unnecessarily. Because of these discrepancies the ESD attention label shown in Figure 7-10 is necessary on these items to restrict additional ESD protective packaging and to inform the handling individual that ESDS items are inside.

7.5.5.15.3 Marking of Packaging Materials (Reference Paragraph 7.5.5.14.1, Paragraph 7.5.5.14.2, and Paragraph 7.5.5.14.3. When ESDS discrete parts, circuit boards, wiring boards, modules, and uniquely shaped items are packaged per Paragraph 7.5.5.14.1, Paragraph 7.5.5.14.2, and Paragraph 7.5.5.14.3, outermost bag will be marked on both sides with the label shown in Figure 7-11. When one or more of these items are packaged into another container for shipping purposes (i.e. Fast Pack, intermediate pack, exterior pack, shipping container) the ESD caution label shown in Figure 7-12 will be placed on the Fast Pack, intermediate pack, exterior pack or shipping container. See MIL-STD-129 for

TO 00-25-234

proper placement and correct size label to be used. See Table 7-3 for NSN and size of label.

7.5.5.15.4 Marking Of Cabinets And Bins Containing ESDS Items. All storage cabinets or parts bins containing ESDS items outlined in Paragraph 7.4.1 shall be marked on

an outside surface clearly visible to personnel approaching the cabinet/bin alerting them that ESDS items are inside. The label displayed in Figure 7-11 shall be used for this function. Note that items enclosed in a complete Faraday Cage are no longer consider ESDS; therefore, cabinets containing these items do not require special marking.

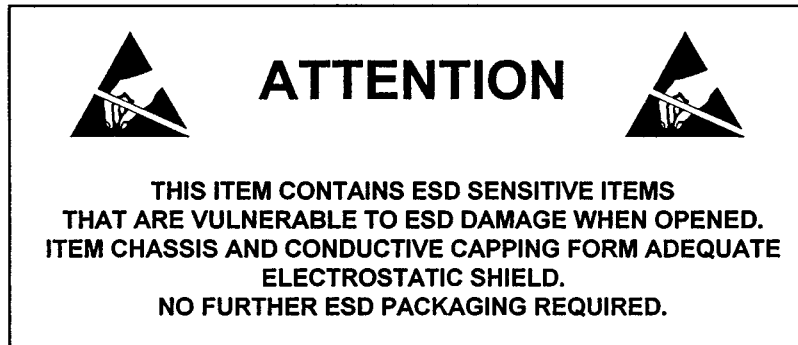

TO-00-25-234-089

Figure 7-9. ESD Attention Label/No Further Packaging Required



TO-00-25-234-090

Figure 7-10. ESD Control Label/ESDS Item Packages (MIL-STD-129)



TO-00-25-234-091

Figure 7-11. ESD Caution Label/Off Base Transport Items (MIL-STD-129)**Table 7-3. ESD Protective Equipment**

Item No.	Item/Nomenclature	NSN	Part Number
1	<p>NOTE</p> <p>Permanent Workstation Size: 72 x 36 (4 drawer storage cabinets, continuous workstation monitor, and dual conductor wrist strap) (reference Paragraph 7.5.5.2). When ordering ensure you specify the “soft” laminate (Norastat) worksurface material. Hard laminates are not approved.</p>	7110-01-377-8160	WEA01N5211VAA or WEA01N5194VAB (w/casters)
2	<p>NOTE</p> <p>Permanent Workstation Size: 72 x 36 (5 drawer storage cabinets, adjustable shelf, continuous workstation monitors and dual wrist strap). When ordering ensure you specify the “soft” laminate (Norastat) worksurface material. Hard laminates are not approved.</p>	7110-01-377-7957	WEA03N5213VAA or WEA03N5195VAB (w/casters)
3	<p>NOTE</p> <p>Permanent Workstation Size: 72 x 36 (5 drawer storage cabinets, shelf, continuous workstation wrist strap). When ordering ensure you specify the “soft” laminate (Norastat) worksurface material. Hard laminates are not approved.</p>	7110-01-377-8155	WEA04N5218VAA or WEA04N5219VAB (w/casters)

Table 7-3. ESD Protective Equipment - Continued

Item No.	Item/Nomenclature	NSN	Part Number
4	<p style="text-align: center;">NOTE</p> <p>Permanent Workstation Size: 72 X 36 (5 drawer storage cabinets, adjustable powered shelf, continuous workstation monitor, dual conductor wrist strap). When ordering ensure you specify the "soft" laminate (Norastat) worksurface material. Hard laminates are not approved.</p>	7110-01-377-5403	WEA04N5209VAA or WEA04N5192VAB (w/casters)
5	<p style="text-align: center;">NOTE</p> <p>Permanent Workstation Size: 72 x 36 (5 drawer storage cabinet, powered shelf, continuous workstation monitor, and dual conductor wrist strap, additional 9 drawer storage cabinet) (reference Paragraph 7.5.5.2). When ordering ensure you specify the "soft" laminate (Norastat) worksurface material. Hard laminates are not approved.</p>	7110-01-377-8152	WEC04N5214VAA or WEC04N5193VAB (w/casters)
6	Permanent Workstation Size: 96 x 36 (2 and 4 drawer storage cabinets, shelf, 2 overhead storage bins, 2 high intensity lights, continuous workstation monitor, and dual conductor wrist strap)	7110-01-378-6454	809636-BESD
7	Permanent Workstation Size: 72 x 30 (2 and 3 drawer storage cabinets, power strip, continuous workstation monitor and dual conductor wrist strap)	7110-01-383-0171	537230-2ESD
8	Permanent Workstation Size: 72 x 36 (2 and 3 drawer storage cabinet, shelf, power strip, continuous workstation monitor and dual conductor wrist strap)	7110-01-377-8897	537236-4ESD
9	Permanent Workstation Size: 72 x 36 (2 and 3 drawer storage cabinet, power strip, continuous workstation monitor and dual conductor wrist strap)	7110-01-377-8896	537236-5ESD
10	Permanent Workstation Size: 80 x 30 (4 and 5 drawer storage cabinets, shelf, power strip, continuous workstation monitor and dual conductor wrist strap)	7110-01-383-1300	807230-3ESD
11	Permanent Workstation Size: 72 x 36 (3 and 4 drawer storage cabinets, shelf, power strip, continuous conductor wrist strap)	7110-01-383-0178	807236-AESD
12	Permanent Workstation Size: 72 x 36 (1 and 2 drawer storage cabinets, shelf, power strip, 2 overhead storage bins, high intensity lighting, continuous workstation monitor and dual conductor wrist strap)	7110-01-382-8050	807236-6ESD
13	Workstation, Static Control (Cushioned Worksurface 2x4 ft.) (reference Paragraph 7.5.5.2)	4940-01-250-4236	
14	Workstation, Static Control (Rigid Worksurface 2x4 ft.) (reference Paragraph 7.5.5.3)	4940-01-250-4235	
15	Workstation, Static Control Portable (reference Paragraph 7.5.5.2)	4940-01-250-4237	
16	Cushioned Static Control Worksurface Only (For workstation specified as item no. 13) (ref Paragraph 7.5.5.2)	5920-01-269-0444	

Table 7-3. ESD Protective Equipment - Continued

Item No.	Item/Nomenclature	NSN	Part Number
17	Rigid Static Control Worksurface Only (For workstation specified as item no. 14) (reference Paragraph 7.5.5.3)	5920-01-269-0443	
18	Portable Static Control Work Surface Only (For workstation specified as item no. 15) (reference Paragraph 7.5.5.4)	5920-01-269-0445	
19	40 ft. Work Surface Runner (4 ft. wide) (Made out of work surface material specified as item no. 16) (reference Paragraph 7.5.5.2)	4940-01-279-4608	
20	Personnel Wrist Strap (Adjustable Cuff and 5 ft coiled cord) (reference Paragraph 7.5.5.5)	5920-01-270-0442	
21	Personnel Wrist Strap (Adjustable Cuff and 10 ft. coiled cord)	5920-01-187-2267	
22	Wrist Strap Adjustable Cuff Only	5920-01-274-0485	
23	Wrist Strap Cord (10 ft.)	5920-01-274-0487	
24	Wrist Strap Cord (5 ft.)	5920-01-274-0486	
25	Single Conductor Metal Wrist Band (sizes: small, medium, large)		2205 2206 2207
26	Single Conductor Metal Wrist Strap Ground Cord (sizes: 5-ft, 10-ft coil cords for use with 2205, 2206, and 2207 wrist strap cuffs)		2210 2220
27	Continuous Workstation Monitors (reference Paragraph 7.5.5.1)		Model 790 Model 724 Series 400 *Series 300 *Model 722 *Model 720 Model SMU-1500
NOTE			
Dual Conductor Wrist Straps must be used with Continuous Workstation Monitors			
28	Dual Conductor Fabric Wrist Strap (band and 5 ft. cord) Size: Small (reference Paragraph 7.5.5.5)		2361
29	Dual Conductor Fabric Wrist Strap (band and 5 ft cord) Size: Medium		2362
30	Dual Conductor Fabric Wrist Strap (band and 5 ft. cord) Size: Large		2363
31	Dual Conductor Fabric Wrist Strap (band only) Size: Small		2364
32	Dual Conductor Fabric Wrist Strap (band only) Size: Medium		2365
33	Dual Conductor Fabric Wrist Strap (band only) Size: Large		2366
NOTE			
The following two common point ground components are required for grounding permanent static control workstations without continuous workstation monitors.			
34	Dual Conductor Metal Wrist Strap (band only) Must specify size: S, M, L		282-000
35	Dual Conductor Fabric Wrist Strap (band only) One size fits all		281-000

TO 00-25-234

Table 7-3. ESD Protective Equipment - Continued

Item No.	Item/Nomenclature	NSN	Part Number
36	Dual Conductor Cord Sizes: 5 ft, 10 ft, 20 ft		200-005 200-010 200-020
37	Dual Conductor Metal Wrist Strap (band and 5-ft cord, 2380 series) Sizes: S, M, L		2381 2382 2383
38	Dual Conductor Metal Wrist Strap (band and 5-ft cord, 2380VM series) Sizes: S, M, L (for use with 790 monitor only)		2381VM 2382VM 2383VM
39	Dual Conductor, Adjustable, Fabric Wrist Band (for use with Model 790)		2368VM
40	Dual Conductor Ground Cord (sizes: 5-ft, 10-ft)		2360 2370
41	Common Point Ground Component (wrist strap portion) for Permanent Static Control Workstations (reference Paragraph 7.5.5.1)		3042
42	CPG Component (wrist strap portion) for Permanent Static Control Workstations (reference Paragraph 7.5.5.1)		4720
43	Common Point Ground Component (work surface portion) for Permanent Static Control Workstations (reference Paragraph 7.5.5.1)		3041
44	Common Point Ground System (for static control workstations containing rigid and cushioned work surfaces), ring terminal (reference Paragraph 7.5.5.6)	4940-01-270-5875	M87893-07
45	Common Point Ground System (for portable static control workstations), clamp terminal (reference Paragraph 7.5.5.6)	4940-01-349-9306	M87893-08
46	Bench Top Ionizing Blower (for use with alpha emitting ionizing source) (reference Paragraph 7.5.5.7)		Model 4062
47	Bench Top Alpha Emitting Ion Bar (Method Acquisition specified paragraph of in Paragraph 7.5.5.7)		Model P-2001B
	NOTE		
	Model 4062 ionizing blower must be used with Model P-2001B ionizing source.		
48	Bench Top Electrical Ionizing Blower (reference Paragraph 7.5.5.7)		*Model 961 Model 963 Aerostat PC ZSTAT Model 6430
49	Static dissipative Gloves pair (reference Paragraph 7.5.5.8) Size: small Note: These gloves are not for use with solvents		25GS 27GS 2D7850 96-133
50	Static Dissipative Gloves, pair Size: Medium Note: These gloves are not for use with solvents		25GM 27GM 2D7851 96-233
51	Static Dissipative Gloves, pair Size: large		25GL

Table 7-3. ESD Protective Equipment - Continued

Item No.	Item/Nomenclature	NSN	Part Number
	Note: These gloves are not for use with solvents		27GL 2D7821 96-333 2D7853
52	Static Dissipative Gloves, pair Size: x-large Note: These gloves are not for use with solvents		
53	Static dissipative Gloves, pair Size: S=small; M=medium; L=large (reference Paragraph 7.5.5.8)		27G-27005; M;L 25G-25005; M;L
54	Static Dissipative Finger Cots Sizes: Small, Medium, Medium/Large, Large/X-Large (must specify size on requisition documents) (reference Paragraph 7.5.5.8)		8C-800
55	Static Dissipative Finger Cots Sizes: Small, Medium, Large		8CS 8CM 8CL
56	Chair, Static Dissipative Upholstered arms, Foot Ring, Contoured Seat, Adjustable Seat Height 22 in. - 27.5 in. (reference Paragraph 7.5.5.9.3)		J757ESDHF
57	Chair, Static Dissipative Foot ring, Contoured Seat, Adjustable Seat Height 22 in. - 27.5 in.		J757ESDBF
58	Chair, Static Dissipative Upholstered arms, Seat Height 22 in. - 27.5 in.		J702ESDH
59	Chair, Static Dissipative Foot ring, Contoured Seat, Adjustable Seat Height 22 in. - 29 in.		E3300ETF801-H-06B
60	Chair, Static Dissipative Upholstered arms, Foot Ring, Contoured Seat, Adjustable Seat Height 21 in. - 29 in.		E3300ETF801-HZ-06B
61	Chair, Static Dissipative, Desk Height, Contoured Fabric Seat, Tilt, Casters, Adjust Height 17-21.5 in.		E3000BT-F852-H-TE-06-E1
62	Chair, Static Dissipative, Mid Bench Height, Contoured Fabric Seat, Tilt, Casters, Footring, Adjust Height 22-29.5 in.		E3300BT-F852-H-TE-06-E1
63	Computer Keyboard Ground Strip (reference Paragraph 7.5.5.12)		*9250
64	Electrostatic Field Meter (reference Paragraph 7.5.5.13.1)	6625-01-254-3059	Model 775 19445 Model 512 PFM-711A Model 718 *FM-300
65	Wrist Strap Tester (reference Paragraph 7.5.5.13.2)		19240 (Battery) 19250 (AC Optional) PMT-872A (AC Optional) WSST-300 (Battery) 8525 (Battery) 98263 (AC) Model 746 (AC/Battery) *Model 745 (Battery) *PMT-872 (Battery) *Model 716

TO 00-25-234

Table 7-3. ESD Protective Equipment - Continued

Item No.	Item/Nomenclature	NSN	Part Number
66	Variable Voltage Megohmmeter (reference Paragraph 7.5.5.13.3)		*Model L-10A (AC) Model 701-M (Battery) Model PRS-801 (Battery) Model PRS-812 (Battery) OHM-STAT RT-1000 (AC/ Rechargeable Battery) *Model MJ460 (AC/ Hand Crank) *Model BM12 (Battery) *Model MJ10 (Hand Crank) *Model MJ537 (AC/ Rechargeable Battery) *PRS-800-M (Battery)
67	Resistance Test Electrodes, pair (2.500 in. dia., 5 lbs.) (reference Paragraph 7.5.5.13.4)	5977-01-305-9120	PRS-801-W 152BP-5P Model 850 701-W *PRS-800-W *260565 CP 940A
68	Conductive Rubber Electrode Pads, 2 each (2.500 in. dia., x.250 in. thick) (reference Paragraph 7.5.5.13.4)		Model 179 Model 77AN PMM-810
69	Ohmmeter/Multimeter (reference Paragraph 7.5.5.13.6) (use of equivalent item permissible)		
	NOTE Equivalent substitution permissible, must be able to measure less than 1 ohm.		
70	Ground Impedance and Utility Wiring Verification Meter (reference Paragraph 7.5.5.13.7)	6625-01-124-5002	PGT 61-164 *PGT 61-154 *PGT-601A *PAK-1A *7106
71	Charged Plate Monitor (0 to 5000 volts range) (reference Paragraph 7.5.5.13.8)	6625-01-337-5308	Model 210
72	Charged Plate Monitor (0 to 5000 volts range)		Model TI 7000 775PVS Model 718A Model 268A
73	Portable Charge Plate Monitor		775PVS PFK-100 *CPM-720A Model 718

Table 7-3. ESD Protective Equipment - Continued

Item No.	Item/Nomenclature	NSN	Part Number
	NOTE		
	Item consists of static field meter with charge plate adapter.		
74	Static Charger		Model 718A
	NOTE		
	Item 73 is needed for use of this item.		
75	Megohmmeter Test Kit (reference Paragraph 7.5.5.13.5)		Model 152 Model 701 *PRS-800 RT-1000
76	Consolidated Test Kit (with change plate monitor and air velocity meter) (reference Paragraph 7.5.5.13.10)		AF AuditKit40 PSK-312 *AF/PAK 201B *AF/PAK 201A
77	Consolidated Test Kit (reference Paragraph 7.5.5.13.10)		*AF/PAK 202C *AF/PAK 202D AF AuditKit30 *AF/PAK 202A *AF/PAK-202B
78	Air Velocity Meter		Pan-750
79	Static Shielding Bags MIL-B-81705C, Type III (reference Paragraph 7.5.5.14) Sizes: (all dimensions in inches) 3x5, 4x4, 4x6, 4x30, 6x8, 6x10, 8x8, 8x10, 8x12, 10x12, 10x14, 10x24, 10x30, 11x15, 12x18, and 18x18	8105-01-361-1677 8105-01-363-7101	2100E 2110E (zipper closure) 2100R 2110R (zipper closure) 8300Z
	NOTE		
	Requisition Documents must include part no. (any of those listed), size, zip lock seal requirement, and statement that the requirements of MIL-B-81705C must be met.		
80	PPP-C-1842, Type III cushion wrap material Size: 0.250 in. x 24 in. x 375 in. (bundle) (reference Paragraph 7.5.5.14.2 Step c)	8135-01-087-3602	
81	PPP-C-1842, Type III cushion wrap material Size: 0.250 in x 12 in. x 375 in.	8135-01-087-3603	
82	PPP-C-1842, Type III cushion wrap material Size: 0.250 in. x 48 in. x 375 in.	8135-01-088-3850	
83	PPP-C-1842, Type III cushion wrap material Size: 0.250 in. x 6 in. x 375 in.	8135-01-088-3851	
84	PPP-C-1842, Type III cushion wrap material Size:	8135-01-087-3599	
	500 ft. x 24 in. x 0.25 in.	8135-01-057-3605	
	500 ft. x 6 in. x 0.25 in.	8135-01-087-3602	
	375 ft. x 24 in. x 0.25 in.		

Table 7-3. ESD Protective Equipment - Continued

Item No.	Item/Nomenclature	NSN	Part Number
85	MIL-P-81997, Type I pouches, cushioned (reference Paragraph 7.5.5.14.2) Size: 8 in. x 8 in.	8105-01-215-0462	
86	MIL-P-81997, Type I pouches, cushioned Size: 8 in. x 12 in.	8105-01-205-0207	
87	MIL-P-81997, Type I pouches, cushioned Size: 10 in. x 10 in.	8105-01-197-2966	
88	MIL-P-81997, Type I pouches, cushioned Size: 10 in. x 12 in.	8105-01-197-7846	
89	MIL-P-81997, Type I pouches, cushioned Size: 12 in. x 12 in.	8105-01-197-2965	
90	MIL-P-81997, Type I pouches, cushioned Size: 11 in. x 15 in.	8105-01-215-4752	
91	MIL-B-81705, Type I material (heat sealable) (reference Paragraph 7.5.5.14) Size: 3 ft. x 600 ft. (roll)	8135-00-092-3220	
NOTE			
This material can be cut and heat sealed to form the bags mentioned in Paragraph 7.5.5.14 Step b. Bags made from this material will be constructed by folding one piece of material and heat sealing on three sides in accordance with MIL-B-117. Do not make the bags from two separate pieces of material.			
92	MIL-B-81705, Type I bag, heat sealable (reference Paragraph 7.5.5.14.1 and Paragraph 7.5.5.14.2) Size: 4 in. x 6 in.	8105-01-236-5944	
93	MIL-B-81705, Type I bag, heat sealable Size: 6 in. x 8 in.	8135-01-235-5473	
94	MIL-B-81705, Type I bag, heat sealable Size: 8 in. x 6 in.	8135-01-235-5474	
95	MIL-B-81705, Type I bag, heat sealable Size: 8 in. x 12 in.	8105-01-236-0149	
96	MIL-B-81705, Type I bag, heat sealable Size: 12 in. x 10 in.	8105-01-235-2688	
97	MIL-B-81705, Type I bag, heat sealable Size: 12 in. x 18 in.	8105-01-235-2689	
98	MIL-B-81705, Type I bag, heat sealable Size: 13 in. x 15 in.	8135-01-235-5476	
99	MIL-B-81705, Type I bag, heat sealable Size: 14 in. x 10 in.	8105-01-236-0150	
100	MIL-B-81705, Type I bag, heat sealable Size: 14 in. x 20 in.	8105-01-243-6628	
101	MIL-B-81705, Type I bag, heat sealable Size: 15 in. x 25 in.	8105-01-243-6629	
102	MIL-B-81705, Type I bag, heat sealable Size: 16 in. x 14 in.	8135-01-235-5477	
103	MIL-B-81705, Type I bag, heat sealable Size: 18 in. x 22 in.	8105-01-235-9829	
104	MIL-B-81705, Type III bag, uncushioned (reference Paragraph 7.5.5.14.1 and Paragraph 7.5.5.14.2). Size: 3 in. x 5 in.	8105-01-120-3382	
	4 in. x 4 in.	8105-01-120-3381	
	4 in. x 6 in.	8105-01-120-3380	
	4 in. x 24 in.	8105-01-119-8111	
	5 in. x 8 in.	8105-01-096-9527	
	5 in. x 10 in.	8105-01-120-3379	
	6 in. x 8 in.	8105-01-235-8223	
	6 in. x 10 in.	8105-01-120-3378	
	8 in. x 8 in.	8105-01-120-3377	
	8 in. x 10 in.	8105-01-120-3376	
	8 in. x 12 in.	8105-01-097-4507	
	9 in. x 15 in.	8105-04-236-3974	
	10 in x 12 in.	8105-01-120-3375	
	10 in. x 14 in.	8105-01-120-3374	
	10 in. x 24 in.	8105-01-119-8110	
	11 in. x 15 in.	8105-01-120-3373	

Table 7-3. ESD Protective Equipment - Continued

Item No.	Item/Nomenclature	NSN	Part Number
	12 in. x 10 in.	8105-01-235-2670	
	12 in. x 16 in.	8105-01-120-3372	
	12 in. x 18 in.	8105-01-096-9528	
	14 in. x 10 in.	8105-01-235-2671	
	14 in. x 18 in.	8105-01-120-3371	
	14 in. x 20 in.	8105-01-235-2672	
	15 in. x 18 in.	8105-01-120-3370	
	15 in. x 25 in.	8105-01-235-5790	
	16 in. x 14 in.	8105-01-235-5791	
	18 in. x 18 in.	8105-01-119-8109	
	18 in. x 22 in.	8105-01-235-2673	
	30 in. x 24 in.	8105-01-235-9141	
105	PPP-C-795, Class 2, cushioning material, flexible, cellular plastic film for packaging applications (reference Paragraph 7.5.5.14.1 Step c) Size: 1/8 in x 12 in x 375 ft 3/16 in x 24 in x 500 ft 3/16 in x 48 in x 500 ft	8135-01-126-6275 8135-01-234-6649 8135-01-235-9142	
106	PPP-C-1752, Type VII, Class 1, Grade B, cushioning material, packaging, unicellular polyethylene foam, flexible, non-charge generating sheet (reference Paragraph 7.5.5.14.1 Step c)		
107	PPP-C-1797, Type II, cushioning material, resilient, low density unicellular, polyethylene foam 0.125 in. to 0.25 in. thick (reference Paragraph 7.5.5.14.1 Step c)		
108	Tote Box, Static Shielding (reference Paragraph 7.5.5.14.3.1) Size: 9 in. x 6.500 in. x 6 in. deep	3990-01-383-4518	4415A
109	Tote Box, Static Shielding Size: 14 in. x 9 in. x 3.500 in. deep		4423A
110	Tote Box, Static Shielding Size: 14.750 in. x 9 in. x 6 in. deep	3390-01-371-9180	4425A
111	Tote Box, Static Shielding Size: 14.750 in. x 9 in. x 8 in. deep	3990-01-060-4089	4425A
112	Tote Box, Static Shielding Size: 20 in. x 15 in. x 12 in. deep	3990-01-414-0622	4432A
113	Tote Box, Static Shielding Size: 20.750 in. x 15.750 in. x 5 in. deep	3990-01-290-5158	4435A
114	Tote Box, Static Shielding Size: 20.750 in. x 15.750 in. x 8 in. deep		4438A
115	Tote Box Cover, Snap-On (fits item no. 101) (reference Paragraph 7.5.5.14.3.1)	3990-01-382-3461	4252A
116	Tote Box Cover, Snap-On (fits items 109, 110, 111)	3990-01-371-9272	4253A
117	Tote Box Cover, Snap-On (fits items 112, 113, 114)	3990-01-422-4538	4254A
118	Container, Static Shielding (for clean applications) (reference Paragraph 7.5.5.14.3.2) Size: 9.12 in. x 6.50 in. x 2.38 in. deep		DC1025XL *DC1025CES
119	Container, Static Shielding (for clean applications) Size: 9.18 in. x 6.44 in. x 3.38 in. deep		DC1035XL *DC1035CES
120	Container, Static Shielding (for clean applications) Size: 9.12 in x 6.44 in. x 4.88 in. deep		DC1050XL *DC1050CES

Table 7-3. ESD Protective Equipment - Continued

Item No.	Item/Nomenclature	NSN	Part Number
121	Container, Static Shielding (for clean applications) Size: 14.69 in. x 9.12 x 2.38 in. deep		DC2025XL *DC2025CES
122	Container, Static Shielding (for clean applications) Size: 14.75 in. x 9.18 in. x 3.38 in. deep		DC2035XL *DC2035CES
123	Container, Static Shielding (for clean applications) Size: 14.81 in. x 9.25 in. x 4.88 in. deep		DC2050XL *DC2050CES
124	Container, Static Shielding (for clean applications) Size: 14.88 in. x 9.31 in. x 5.88 in. deep		DC2060XL *DC2060CES
125	Container, Static Shielding (for clean applications) Size: 14.81 in. x 9.25 in. x 6.88 in. deep		DC2070XL *DC2070CES
126	Container, Static Shielding (for clean applications) Size: 14.75 x 9.18 in. x 7.88 in. deep		DC2080XL *DC2080CES
127	Container, Static Shielding (for clean applications) Size: 20.12 in. x 15.12 in. x 4.88 in. deep		DC3050XL *DC3050CES
128	Container, Static Shielding (for clean applications) Size: 20.12 x 15.12 in. x 5.88 in. deep		DC3060XL *DC3060CES
129	Container, Static Shielding (for clean applications) Size: 20.12 in. x 15.12 in. x 7.88 in. deep		DC3070XL *DC3070CES
130	Container, Static Shielding (for clean applications) Size: 20.12 in. x 15.12 in. x 11.88 in. deep		DC3120XL *DC3120CES
131	Container Cover, Static Shielding (for use with items 117, 118 and 119) (reference Paragraph 7.5.5.14.3.2)		CDC1040-ESD *CDC1040CES
132	Container Cover, Static Shielding (for use with items 120, 121, 122, 123, 124 and 125)		CDC2040-ESD *CDC2040CES
133	Container Cover, Static Shielding (for use with items 126, 127, 128, 129)		CDC3040-ESD *CDC3040CES
134	Container, Static Shielding with hinged lid (for clean applications) (reference Paragraph 7.5.5.14.3.2) Size: 2.875 in. x 1.1875 in. x 0.500 in. deep		4021
135	Container, Static Shielding with hinged lid (for clean applications) Size: 3.875 in. x 1.937 in. x 0.500 in. deep		4022
136	Container, Static Shielding with hinged lid (for clean applications) Size: 2.500 in. x 3.500 in. x 1.750 in. deep		4023
137	Container, Static Shielding with hinged lid (for clean applications) Size: 7 in. x 3.500 in. x 1 in. deep		4024
138	Container, Static Shielding with hinged lid (for clean applications) Size: 7 in. x 5 in. x 0.500 in. deep		4025
139	Conductive Trays, Nested & Stacked Boxes (various sizes; substitute appropriate model & size in place of 'xxxxx')		xxxxx0 5167
140	Conductive Trays, Nested & Stacked Boxes (various sizes; substitute appropriate model & size in place of 'xxxxx')		xxxxx9 2203
141	Conductive Divider Tote Box Line (various sizes; substitute appropriate model & size in place of 'xxxxxxx')		xxxxxxxCAS
142	Conductive, Non-corrosive Foam, Low Density for use in tote boxes and containers in items through 122) reference Paragraph 7.5.5.14.3 Size: 1.250 in. thick x 56 in. wide x 3 ft. length		*CEC125X1
143	Conductive, Non-corrosive Foam, Low Density Size: 1.250 in. thick x 56 in. wide x 6 ft. length		*CEC125X2

Table 7-3. ESD Protective Equipment - Continued

Item No.	Item/Nomenclature	NSN	Part Number
144	Conductive, Non-corrosive Foam, Low Density Size: 1.250 in. thick x 56 in. wide x 12 ft. length		*CEC125X4
145	Conductive, Non-corrosive Foam, Low Density Size: 1.250 in. thick x 56 in. wide x 16 ft. length		*CEC125X16
146	Conductive, Non-corrosive Foam, Low Density Size: 1.250 in. thick x 56 in. wide x 32 yds. length		*CEC125X32
147	Conductive, Non-corrosive Foam, Low Density Size: 0.500 in. thick x 56 in. wide x 3 ft. length		*CEC500X1
148	Conductive, Non-corrosive Foam, Low Density Size: 0.500 in. thick x 56 in. wide x 6 ft. length		*CEC500X2
149	Conductive, Non-corrosive Foam, Low Density Size: 0.500 in. thick x 56 in. wide x 12 ft. length		*CEC500X4
150	Conductive, Non-corrosive Foam, Low Density Size: 0.500 in. thick x 56 in. wide x 16 yards length		*CEC500X16
151	Conductive, Non-corrosive Foam, Low Density Size: 0.500 in. thick x 56 in. wide x 32 yards length		*CEC500X32
152	Conductive, Non-corrosive Foam, Low Density, for use in tote boxes and containers (reference Paragraph 7.5.5.14.3) Sizes: 0.125 in. thick x 39 in. wide x 39 in. length 0.250 in. thick x 39 in. wide x 39 in. length 0.375 in. thick x 39 in. wide x 39 in. length 0.500 in. thick x 39 in. wide x 39 in. length		2802
NOTE			
Requisition Documents must include part number, and size. The shipping unit is a box of 10 sheets of foam.			
153	Conductive Foam Sizes: 1/4 in. x 24 in. x 36 in. 3/8 in. x 24 in. x 36 in. 1/2 in. x 24 in. x 36 in. 3/4 in. x 24 in. x 36 in.		12250 12350 12450 12550
154	Conductive Foam, Closed-cell Cross Linked Polyethylene Size: 1/4" x 24" x 35"		12660
155	Conductive Foam, Lead Insertion Grade, Sizes: 1/4 x 2-7/16 x 1 in (6 X 62 X 25 mm) 1/4 x 3-3/16 x 1 in (6 X 81 X 25 mm) 1/4 x 4-3/16 x 1-1/4 in (6 X 106 X 32 mm) 1/4 x 3-3/16 x 1-7/8 in (6 X 106 X 48 mm) 1/4 x 3-1/2 x 3-1/2 in (6 X 89 X 89 mm) 1/4 x 6-3/4 x 3-3/8 in (6 X 171 X 86 mm) 1/4 x 3-3/4 x 2-3/4 in (6 X 95 X 70 mm) 1/8 x 36 x 60 in (3 X 914 X 1524 mm) 1/4 x 36 x 60 in (6 X 914 X 1524 mm) 3/8 x 36 x 60 in (10 X 914 X 1524 mm) 1/2 x 36 x 60 in (15 X 914 X 1524 mm) 5/16 x 36 x 60 in (8 X 914 X 1524 mm)		37640 37641 37642 37643 37644 37645 37646 37704 37705 37706 37707 37708
156	Conductive Foam, Cushion Grade, Sizes: 1/8 x 37 x 57 in (3 X 940 X 1448 mm)		37680

TO 00-25-234

Table 7-3. ESD Protective Equipment - Continued

Item No.	Item/Nomenclature	NSN	Part Number
	1/4 x 37 x 57 in (6 X 940 X 1448 mm)		37681
	3/8 x 37 x 57 in (10 X 940 X 1829 mm)		37682
	1/2 x 37 x 57 in (13 X 940 X 1829 mm)		37683
157	Conductive Connector Cap, Circular (reference Paragraph 7.5.5.14.4) Size: 0.250 in. dia., 0.500 in. depth	5340-01-434-2311	M5501/31-250
158	Conductive Connector Cap, Circular Size: 0.313 in dia., 0.500 in. depth	5340-01-434-2317	M5501/31-313
159	Conductive Connector Cap, Circular Size: 0.375 in. dia., 0.500 in. depth	5340-01-434-2321	M5501/31-375
160	Conductive Connector Cap, Circular Size: 0.413 in. dia., 0.625 in. depth	5340-01-434-2324	M5501/31-413
161	Conductive Connector Cap, Circular Size: 0.480 in. dia., 0.500 in. depth	5340-01-434-2328	M5501/31-480
162	Conductive Connector Cap, Circular Size: 0.500 in. dia., 0.500 in. depth	5340-01-434-2329	M5501/31-500
163	Conductive Connector Cap, Circular Size: 0.530 in. dia., 0.625 in. depth	5340-01-434-2333	M5501/31-530
164	Conductive Connector Cap, Circular Size: 0.605 in. dia., 0.500 in. depth	5340-01-434-2335	M5501/31-605
165	Conductive Connector Cap, Circular Size: 0.655 in. dia., 0.625 in. depth	5340-01-434-2345	M5501/31-655
166	Conductive Connector Cap, Circular Size: 0.720 in. dia., 0.500 in. depth	5340-01-434-2349	M5501/31-720
167	Conductive Connector Cap, Circular Size: 0.785 in. dia., 0.625 in. depth	5340-01-434-2359	M5501/31-785
168	Conductive Connector Cap, Circular Size: 0.850 in. dia., 0.500 in. depth	5340-01-434-2360	M5501/31-850
169	Conductive Connector Cap, Circular Size: 0.893 in. dia., 0.625 in. depth	5340-01-434-2363	M5501/31-893
170	Conductive Connector Cap, Circular Size: 0.973 in. dia., 0.500 in. depth	5340-01-434-2367	M5501/31-973
171	Conductive Connector Cap, Circular Size: 1.028 in. dia., 0.625 in. depth	5340-01-434-2366	M5501/31-1028
172	Conductive Connector Cap, Circular Size: 1.093 in. dia., 0.625 in. depth	5340-01-434-2369	M5501/31-1093
173	Conductive Connector Cap, Circular Size: 1.125 in. dia., 0.560 in. depth	5340-01-434-2370	M5501/31-1125
174	Conductive Connector Cap, Circular Size: 1.150 in. dia., 0.625 in. depth	5340-01-434-2376	M5501/31-1150
175	Conductive Connector Cap, Circular Size: 1.231 in. dia., 0.562 in. depth	5340-01-434-2378	M5501/31-1231
176	Conductive Connector Cap, Circular Size: 1.270 in. dia., 0.625 in. depth	5340-01-434-2387	M5501/31-127
177	Conductive Connector Cap, Circular Size: 1.340 in. dia., 0.562 in. depth	5340-01-434-2388	M5501/31-1340
178	Conductive Connector Cap, Circular Size: 1.390 in. dia., 0.625 in. depth	5340-01-434-2392	M5501/31-1390
179	Conductive Connector Cap, Circular Size: 1.463 in. dia., 0.562 in. depth	5340-01-434-2393	M5501/31-1463
180	Conductive Connector Cap, Circular Size: 1.540 in. dia., 0.625 in. depth	5340-01-434-2401	M5501/31-1540

Table 7-3. ESD Protective Equipment - Continued

Item No.	Item/Nomenclature	NSN	Part Number
181	Conductive Connector Cap, Circular Size: 1.645 in. dia., 0.625 in. depth	5340-01-434-2394	M5501/31-1645
182	Conductive Connector Cap, Circular Size: 1.715 in. dia., 0.562 in. depth	5340-01-434-2395	M5501/31-1715
183	Conductive Connector Cap, Circular Size: 1.890 in. dia., 0.625 in. depth	5340-01-434-2403	M5501/31-1890
184	Conductive Connector Cap, Circular Size: 1.965 in. dia., 0.562 in. depth	5340-01-434-2407	M5501/31-1965
185	Conductive Connector Cap, Circular Size: 2.140 in. dia., 0.625 in. depth	5340-01-434-2410	M5501/31-2140
186	Conductive Connector Cap, Circular Size: 2.215 in. dia., 0.600 in. depth	5340-01-434-2412	M5501/31-2215
187	Conductive Connector Cap, Circular Size: 2.380 in. dia., 0.625 in. depth	5340-01-434-2414	M5501/31-2380
188	Conductive Connector Cap, Circular Size: 2.440 in. dia., 0.600 in. depth	5340-01-434-2418	M5501/31-2440
189	Conductive Connector Cap, Circular Size: 2.630 in. dia., 0.625 in. depth	5340-01-434-2425	M5501/31-2630
190	Conductive Connector Cap, Circular Size: 2.720 in. dia., 0.600 in. depth	5340-01-434-2426	M5501/31-2720
191	Conductive Connector Cap, Circular Size: 2.880 in. dia., 0.625 in. depth	5340-01-434-2427	M5501/31-2880
192	Conductive Connector Cap, Circular Size: 2.960 in. dia., 0.600 in. depth	5340-01-434-2429	M5501/31-2960
193	Conductive "D" Connector Cap Size: 0.469 in. height, 2.112 in. width 0.249 in depth (reference Paragraph 7.5.5.14.4)	5340-01-434-2319	M5501/32-50P
194	Conductive "D" Connector Cap Size: 0.407 in. height, 2.049 in. width, 0.249 in. depth	5340-01-434-2315	M5501/32-50S
195	Conductive "D" Connector Cap Size: 0.363 in. height, 2.216 in. width, 0.249 in. depth	5340-01-434-2313	M5501/32-37P
196	Conductive "D" Connector Cap Size: 0.295 in. height, 2.143 in. width, 0.249 in. depth	5340-01-434-2310	M5501/32-37S
197	Conductive "D" Connector Cap Size: 0.363 in. height, 1.568 in. width ,0.249 in. depth	5340-01-434-2306	M5501/32-25P
198	Conductive "D" Connector Cap Size: 0.295 in. height, 1.495 in. width, 0.249 in. depth	5340-01-434-2305	M5501/32-25S
199	Conductive "D" Connector Cap Size: 0.369 in. height, 1.040 in. width, 0.249 in. depth	5340-01-434-2303	M5501/32-15P
200	Conductive "D" Connector Cap Size: 0.295 in. height, 0.955 in. width, 0.249 in. depth	5340-01-434-2304	M5501/32-15S
201	Conductive "D" Connector Cap Size: 0.367 in. height, 0.682 in. width, 0.249 in. depth	5340-01-434-2183	M5501/32-9P
202	Conductive "D" Connector Cap Size: 0.295 in. height, 0.627 in. width, 0.249 in. depth	5340-01-434-2302	M5501/32-9S
203	Metal BNC Connector Cap (with chain)	5935-00-885-2264	
204	Connector Cap Custom Made caps for uniquely shaped connectors (reference Paragraph 7.5.5.14.4)		
205	Cable Connector Cover Size: 2.5 in. dia., 4.25 in. length (reference Paragraph 7.5.5.14.4)	5935-01-388-6495	

TO 00-25-234

Table 7-3. ESD Protective Equipment - Continued

Item No.	Item/Nomenclature	NSN	Part Number
206	MIL-STD-1285 Sensitive Electronic Device Symbol (reference Figure 7-8) Sizes: 0.25 in. x 0.25 in. 0.50 in. x 0.50 in. 1 in. x 1 in. 2 in. x 2 in. 6 in. x 6 in.	See Base Publications Distribution Office for Production of labels.	
207	MIL-STD 1686 ESD Caution Statement (reference Paragraph 7.5.5.15.1) Sizes: 0.25 in. x 1.75 in. 1 in. x 3.50 in. 2 in. x 7 in.	See Base Publications Distribute Office for Production of labels.	
208	MIL-STD-1285 Symbol/MIL-STD 1686 Caution Statement Combined (reference Figure 7-9) Sizes: 0.50 in. x 1 in. 1 in. x 2 in. 2 in. x 4 in. 4 in. x 8 in.	See Base Publications Distribution Office for Production of labels.	
209	ESD Attention Label/No Further Packaging Required (reference Figure 7-10) Sizes: 0.50 in. x 1 in. 1 in. x 2 in. 2 in. x 4 in. 4 in. x 8 in.	See Base Publications Distribution Office for Production of labels.	
210	Sensitive Electronic Device Label (For outermost bag or package) (reference Figure 7-11) Size: 2 in. x 0.625 in. (Optical form 88)	7540-01-317-7371	
211	Sensitive Electronic Device Caution Label (Fast Pack, intermediate pack, exterior pack or shipping container (reference Figure 7-12) Sizes: 2 in. x 2 in. (optional form 87) 4 in. x 4 in. (optional form 87-A)	7540-01-109-8815 7540-01-110-4906	
212	Isopropyl Alcohol 99%, 1 Gallon (use of equivalent item available in different quantities Permissible). (reference Paragraph 7.5.8) Isopropyl Alcohol 70%, 4 Liter, CAGE 22527, (use of equivalent item available in different quantities permissible). (reference Paragraph 7.5.8) Local purchase use General Service Administration	6810-00-227-0410	A459-4
213	Thermoformable Conductive Sheet Material (for connector caps) 1/16 inch thick x 4ft x 8ft (reference Paragraph 7.5.5.14)		1801
214	Vacuum, Static Dissipative (reference Paragraph 7.5.8 Step c)	7910-01-232-4503	Series 497

Table 7-3. ESD Protective Equipment - Continued

Item No.	Item/Nomenclature	NSN	Part Number
215	Tape Adhesive, Non-Charge Generating Size: 1 in. x 72 yd., 3 in. core		WATP-3-1 81211
216	Tape Adhesive, Non-Charge Generating Size: 2 in. x 72 yd., 3 in. core		WATP-3-2 81212
217	Tape Adhesive, Non Charge Generating sizes: 0.250 in. x 72 yd., 3 in. core 0.375 in. x 72 yd., 3 in. core 0.500 in. x 72 yd., 3 in. core 0.500 in. x 36 yd., 1 in. core 0.625 in. x 72 yd., 3 in. core 0.750 in. x 72 yd., 3 in. core 0.750 in. x 36 yd., 1 in. core 0.875 in. x 72 yd., 3 in. core 1.000 in. x 72 yd., 3 in. core 2.000 in. x 72 yd., 3 in. core		Model 40
218	Tape Adhesive, Electrically Conductive sizes: 0.50 in. x 36 yd. 0.75 in. x 36 yd. 1 in. x 36 yd.		9703
	NOTE		
	Not to be used for general everyday package sealing, etc. Use should be consistent with manufacturers recommended usage's.		
219	Tape Adhesive, Non Charge Generating 1/2 in x 72 yds. roll 3/4 in x 72 yds. roll 1 in x 72 yds. roll 2 in x 72 yds. roll 1/2 in x 72 yds. (72 rolls/case) 3/4 in x 72 yds. (48 rolls/case) 1 in x 72 yds. (36 rolls/case) 2 in x 72 yds. (18 rolls/case)		728PT-1/2 728PT-3/4 728PT-1 728PT-2 205107SP-1/2 205107SP-3/4 205107SP-1 205107SP-2
220	Camel Hair Brush, 1 inch wide, round (use of equivalent camel hair brush permissible)	7920-00-205-0565	
221	Camel Hair Brush, 2 inch wide, flat (use of equivalent camel hair brush permissible)	8020-00-051-7098	
222	Detergent, General Purpose 16 ounce spray bottle, 48 each (use of substitute item permissible)	7930-00-926-5280	
223	Cleaner, Glass 16 ounce spray bottle, 12 each (use of substitute item permissible)	7930-01-326-8110	
224	Cabinet, Storage, Size: 59.130 in. height x 30.000 in. width x 27.750 in. depth, steel, 12 drawers, lock, partitions, dividers, bins, ground cord	7125-01-181-7665	340STDE5008VC
225	Cabinet, Storage, Size: 30.000 in. height x 30.000 in. width x 27.750 in. depth, steel, 6 drawers, lock, partitions, dividers, bins, ground cord	7125-01-181-7664	155STDE5002VC
226	1/4-inch Conductive Hose 5/16-inch Conductive Hose		HS-01U-VC4 HS-01U-VC5

NOTE

Any item in Table 7-3 that is preceded by an asterisk (*) in the Part Number column may no longer be available for purchase, however, these items are still acceptable for use. When NSNs are not available for the ESD Control products desired, per Table 7-3, ensure that a product specification is attached to the requisitioning documents and that it is called out therein as being a requirement of the item(s) being procured. See your facilities ESD Control Program Monitor to obtain these specifications. NSNs will be provided for all items listed in Table 7-3 when they become available. Additional product information can be obtained through the Air force ESD Control Technology Center. Unique ESD control items may be approved for use through the ESD Control Technology Center without listing them in Table 7-3. Items procured prior to Change 12 of this technical order, and not listed in Table 7-3, are approved for use if the item passes the applicable periodic test requirements of Paragraph 7.8. One exception to this rule is permanent ESD control workstations which require an additional charge dissipation test. Contact the ESD control technology center for further guidance.

7.5.6 Grounding. The ESD protective workstations, storage cabinets and flooring systems specified within Paragraph 7.5.4 shall be properly grounded in accordance with the requirements outlined in this paragraph. Personnel safety is addressed to the extent that parameters and procedures specified in this section, if correctly implemented should minimize hazardous conditions for operators, technicians and other Air Force personnel. The ultimate responsibility for personnel safety must reside with the end user of this document.

7.5.6.1 ESD Ground Measurement Reference Point. The equipment grounding conductor at the service entrance (Figure 7-14) shall be considered the ground reference point for ESD Control for powered indoor operations. Flightline maintenance operations shall utilize the ground terminations used to ground aircraft on the runways or taxi aprons as the ground reference point for ESD Control.

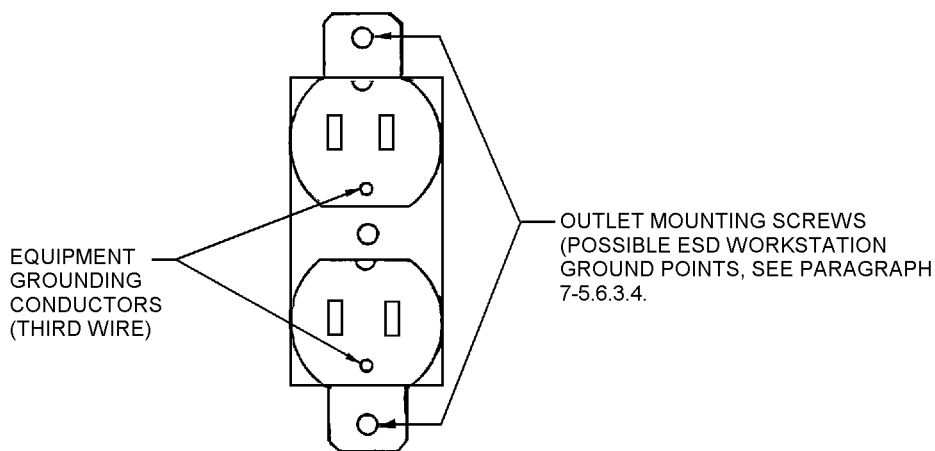

TO-00-25-234-092

Figure 7-12. Typical Electrical AC Outlet

7.5.6.2 Equipment Required For ESD Ground Integrity Checks. The test equipment required to do ESD ground integrity checks is specified in Paragraph 7.5.5.13.6 and Paragraph 7.5.5.13.7. They include a D.C. Ohmmeter and Ground Impedance and Utility Wiring Verification Meter.

7.5.6.3 ESD Control Workstation Grounding (Indoor Powered Operations). The ESD Control Workstations specified in Paragraph 7.5.5.1, Paragraph 7.5.5.2 and Paragraph 7.5.5.3 all contain an ESD grounding conductor in the form of an insulated wire extending from the common point

ground connector (see Figure 7-3, Figure 7-4 and Figure 7-5). Figure 7-14 shows the wiring orientation of a typical service entrance. The third wire of a typical electrical AC outlet (shown as the load) represents a point electrically the same as the equipment grounding conductor at the service entrance. This equipment grounding conductor is brought to work areas via the third wire in power lines and receptacles. The following steps shall be taken to find an acceptable ground point for the ESD Control workstation(s) used in the area.

7.5.6.3.1 Locate an electrical AC outlet that has an equipment grounding conductor (third wire). This does not include the use of outlets that are a part of or connected to the ESD Control workstation. Figure 7-13 shows a typical electrical AC outlet with an equipment grounding conductor. Isolated ground receptacles, typically having a triangular conductor on the plug, shall not be used.

7.5.6.3.2 Using the Ground Impedance and Utility Wiring Verification Meter verify that the selected electrical AC outlet has the proper wiring orientation by checking:

- * Hot, neutral and equipment ground wires are present and not reversed.
- * Hot, neutral and equipment ground wires are not shorted.
- * Hot, neutral and equipment ground wires are not open.

NOTE

If the outlet is not wired correctly report the discrepancy to the responsible facility grounding official and area supervisor. Continue measuring outlets until one with the proper wiring orientation is found.

7.5.6.3.3 When an acceptable outlet is found, measure the impedance between the equipment grounding conductor and the neutral conductor using the same meter. It shall be less than one ohm. If this impedance is greater than one ohm, report the findings to the responsible facility grounding official. If the ground impedance is less than one ohm, it can be concluded that the equipment grounding conductor in the outlet is an acceptable ground reference point for ESD control workstation grounding.



This test may deactivate any operational ground fault circuit interrupters that are connected in the same circuit.

7.5.6.3.4 Any outlet mounting screw, metal raceway, metal conduit box, metal plug mold or metallic structure surrounding the electrical outlet that can be electrically shown to be the same electrical potential as the acceptable equipment grounding conductor found in Paragraph 7.5.6.3.3 shall be used to ground an ESD Control workstation.

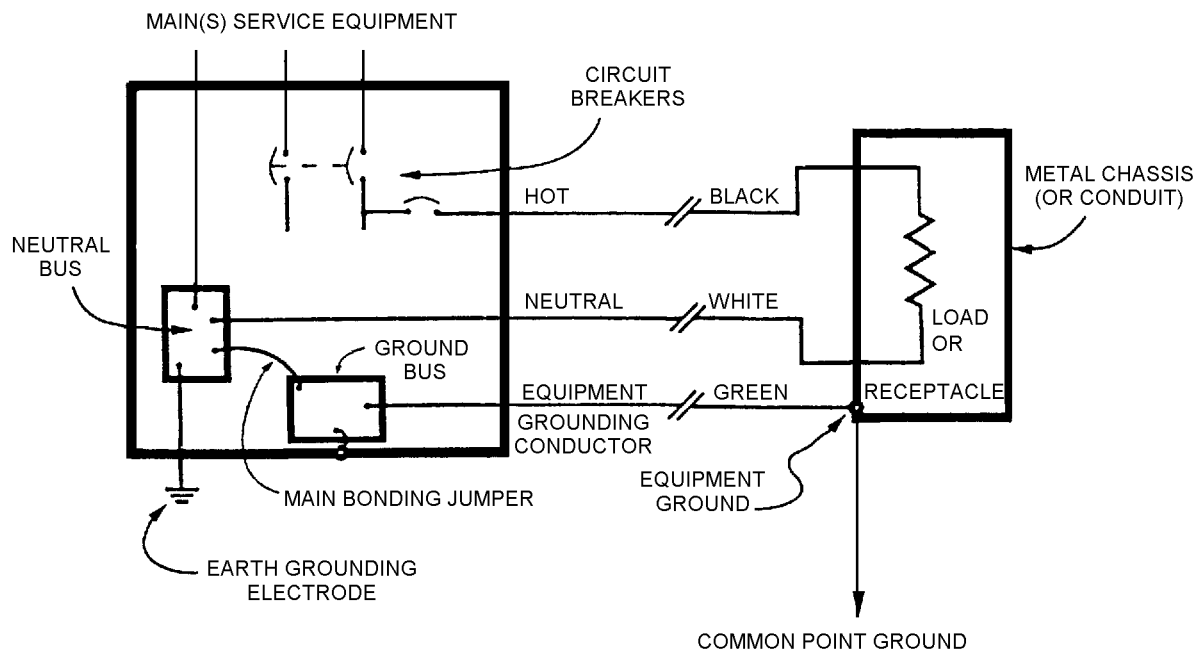

TO-00-25-234-093

Figure 7-13. Typical Service Entrance

TO 00-25-234

7.5.7 Grounding Point.**WARNING**

DO NOT USE the round female equipment grounding conductor hole (third wire) to ground ESD control workstations.

To locate an acceptable grounding point: Measure the resistance between it and the equipment grounding conductor (third wire) of the electrical outlet using an ohmmeter. The resistance shall be less than 1 ohm. Mechanically fasten the ESD Control workstation ground wire to this point and verify the integrity of the connection. Do this by measuring the resistance between the countersink screw (for personal workstations) or the ground snap fastener on the detachable common point ground (for all other workstations) and the equipment grounding conductor (third wire). This resistance shall be either less than one ohm or 1×10^6 ohms \pm 20%. A 1×10^6 ohm measurement means that a current limiting resistor exists within the workstation ground cord. Both resistances are acceptable for workstation grounding. Any value between or above these two values (with tolerances) are not accept-

able, and the workstation ground wire must be replaced. The flow chart in Figure 7-15 summarizes these ESD Control Workstation grounding procedures.

7.5.7.1 ESD Control Workstation Grounding (Building Steel). The ESD Control workstations specified in Paragraph 7.5.5.1, Paragraph 7.5.5.2, and Paragraph 7.5.5.3 can also be grounded by mechanically attaching their ground cords (see Figure 7-3, Figure 7-4, and Figure 7-5) directly to building or structural steel when this ground point is electrically traceable to the equipment grounding conductor at the building service entrance in which the ESD Control workstation(s) are being installed. If power outlets exist in the area, the steps specified in Paragraph 7.5.6.3 must be followed to ensure the wiring orientation and the ground impedance associated with the power outlet(s) are acceptable (see Figure 7-15, steps 2 and 3). This provides a reference within the work area against which the selected building or structural steel ground point can be verified. Use an ohmmeter to verify that the resistance between the grounding conductor (third wire) of the already tested outlet and the selected building or structural steel ground point is less than 1 ohm. If it is, then this point can be used to mechanically attach the ESD Control workstation.

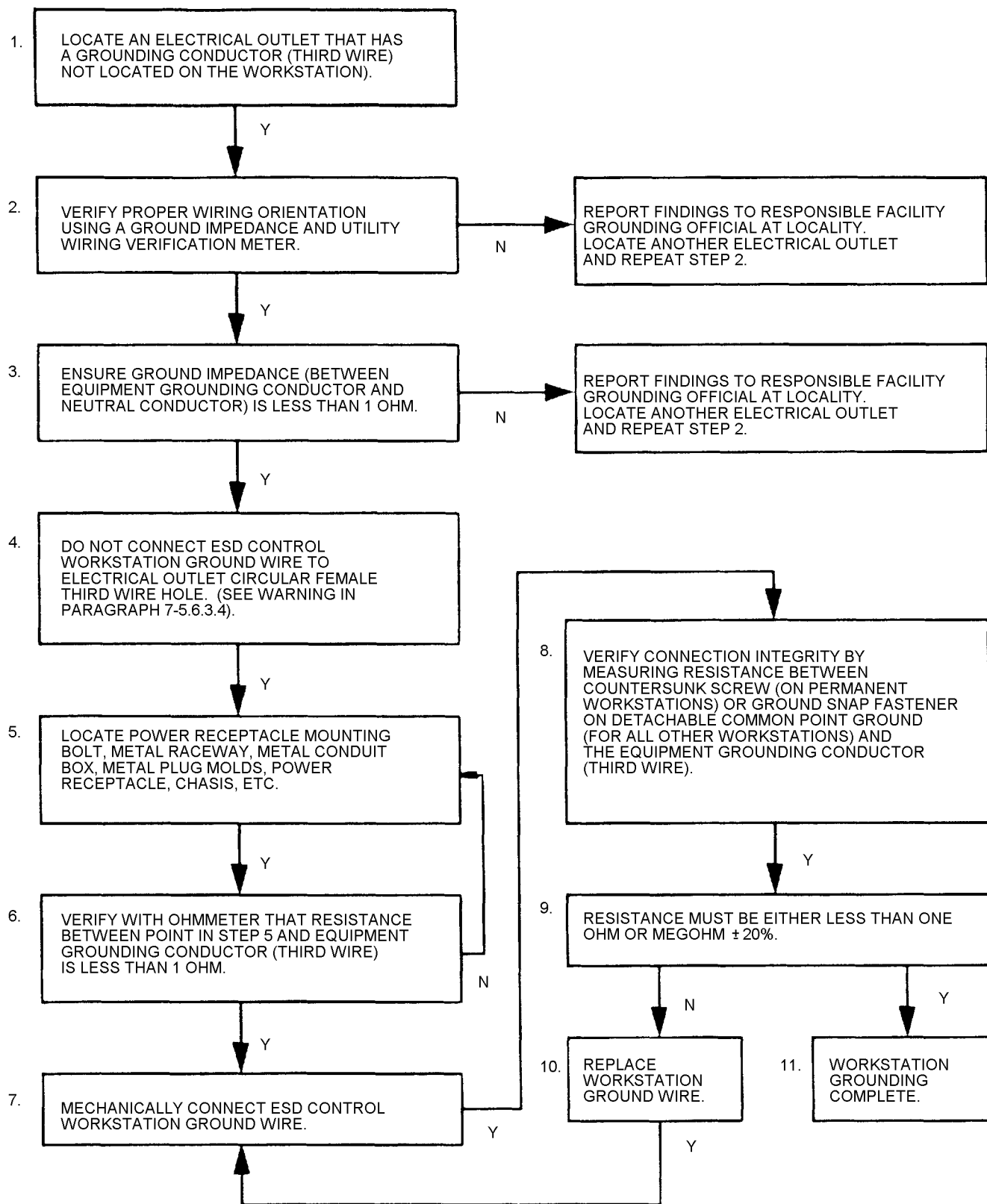

TO-00-25-234-094

Figure 7-14. Flow Chart for ESD Control Workstation Grounding

TO 00-25-234

7.5.7.2 Storage Cabinets and Static Dissipative Floor Grounding. Cabinets and flooring shall be connected to verified ground points as specified for ESD Control workstations in Paragraph 7.5.6.3 and Paragraph 7.5.7.1. Each storage cabinet shall have an insulated ground wire mechanically attached to the cabinet and the grounding point in a manner similar to the ESD Control workstations mentioned previously. Floors shall have one ground wire per 10,000 square feet or part thereof with a minimum of 2 grounding points per floor.

7.5.7.2.1 Grounding conductors for floors shall be:

Raised Floors: A No. 8 copper wire shall be bonded from a pedestal to the verified ground point. Appropriate oxide inhibitors shall be used between the base metal of the raised floor pedestal and the copper connection.

Tile or Poured-In-Place Floors: 1 inch (minimum) wide copper strip shall be bonded from the epoxy used to secure the tile or poured material to a verified ground point. The grounding conductor shall be sufficiently thick to not break or tear easily.

7.5.7.3 Portable ESD Control Workstation and Personnel Wrist Strap Grounding (Remote Indoor or Outdoor Operations). Portable ESD Control workstations or personnel wrist straps that are required for use shall be properly grounded. Since these workstations or wrist straps are used for remote handling of ESDS items (i.e. flightline or organizational level maintenance, airborne activities, remote test equipment), their grounding requirements are different. When the workstation or wrist strap is used during aircraft or missile organizational level maintenance, the grounding wire for the workstation or wrist strap shall be grounded (clipped) to a point on the aircraft/assembly that is electrically the same as the point to which the aircraft/assembly is grounded (i.e. runway, taxi apron, hanger, silo, test facility, etc.). A predesignated grounding point must be used or the integrity of the selected grounding point verified. When the portable ESD Control workstation is used to repair remote test equipment or any equipment items containing ESDS items per Paragraph 7.4.1, it shall be grounded (clipped) to a point on the chassis, site ground, or to the equipment grounding conductor (third wire) of the power lines used to power the equipment. This grounding requirement shall be verified annually or during subsequent maintenance activities at the remote site. For third wire ground situations, verify that the resistance between the selected ESD portable workstation ground point on the equipment chassis and the grounding conductor (third wire) of the supplied power receptacle (outlet) is less than one ohm. In situations where site grounds are used in remote maintenance operations (missile LF, LCF, etc.) this resistance shall be less than ten ohms. If it is, the ESD Control portable workstation can be clipped to this point.

7.5.7.4 Use of Ground Fault Interrupters (GFI) for ESD Control Purposes.

WARNING

The personnel wrist strap shall not be worn when working on energized parts, assemblies and equipment. This requirement does not apply in situations where the powered equipment is operated normally (e.g., not opened up for maintenance, etc.), and no contact with live voltage and/or current is possible. In situations where the manufacturer recommends wearing a wrist strap on energized equipment where contact with live voltage/current is possible, the wrist strap may be worn if approval is granted from the local safety office.

The use of GFIs when grounding ESD Control workstations, storage cabinets or floor systems are not required. GFIs require adequate amounts of current to be activated and are not effective at controlling current available from the secondary winding of transformers or voltage increasing/ decreasing components of equipment at the workstation. Static dissipative work surfaces such as those specified in this section for all ESD Control workstations and the corresponding personnel wrist straps contain large amounts of resistance either in the work surface material itself or in the form of a current limiting resistor which limits the current to levels below what is necessary to activate a GFI. The GFI is useful in applications where metallized conductive work surfaces are used around powered equipment that may short circuit and energize the entire work surface.

NOTE

Use of a GFI should be a safety consideration anytime powered equipment is used and should not be construed as an ESD Control requirement.

7.5.7.5 Personnel Safety. The safety requirements of MILSTD-454, Requirement 1 shall be considered in the installation of ESD Control workstations, storage cabinets and floor systems to reduce the chance of electrical shock to personnel.

7.5.7.5.1 Current rather than voltage is the most important variable in establishing the criterion for shock intensity. Three factors that determine the severity of electrical shock are: (1) magnitude of current flowing through the body; (2) path of current through the body; and (3) duration of time that the current flows through the body. The voltage necessary to produce a fatal current is dependent upon the resistance of the body, contact conditions, and the path through the body (see Table 7-4).

Table 7-4. Effects of Electrical Current on Humans (Reference MIL-STD-454)

Current Values (Milliamperes)		Effect
AC	DC	
25 Hz to 400 Hz		
0-1	0-4	Perception
1-4	4-15	Surprise
4-21	15-80	Reflex action
21-40	80-160	Muscular inhibition
40-100	160-300	Respiratory block
Over 100	Over 300	Usually fatal

7.5.7.5.2 Sufficient current passing through any part of the body will cause severe burns and hemorrhages. However, relatively small currents can be lethal if the path includes a vital part of the body, such as the heart or lungs. Electrical burns are usually produced by heat from the arc which occurs when the body touches a high-voltage circuit. Electrical burns are also caused by passage of electrical current through the skin and tissue. AC currents of 4 to 21 milliamperes can cause reflex action. Although not electrically dangerous this could result in other safety hazards to people or equipment.

7.5.7.6 Other Grounding Requirements. Other grounding and safety considerations that shall be implemented in ESD protected work areas are as follows:

- a. ESD Control workstations shall be tied independently to an acceptable ground point as determined per Paragraph 7.5.6. Workstations shall not be tied together electrically in series.
- b. Resistance(s) to ground shall be high enough considering all parallel paths, to limit leakage current to personnel to 1 milliampere maximum based upon the highest voltage source accessible by grounded personnel. Such voltage sources include power sources and test equipment.
- c. The ground connection of ESD Control workstations, storage cabinets and floor systems shall be of sufficient mechanical strength to minimize the possibility of inadvertent ground disconnections.
- d. The location of current limiting resistors in personnel wrist straps shall be as specified in Paragraph 7.5.5.5.
- e. Nozzles for compressed air, dry nitrogen, hot air blowers, or vacuum systems shall be inherently static dissipative or conductive and grounded (see also Paragraph 7.5.8 Step c). If the conductive nozzle is ungrounded (verify with an ohmmeter per Paragraph 7.8.12), bond one end of No. 16 copper wire to the conductive nozzle, then bond the other end to an acceptable ground point as outlined in Paragraph 7.5.6. Inherently conductive hose (Table 7-3, item number 208) may also be used with conductive nozzles to eliminate the need

for the separate ground wire. Alternatively, nozzle grounding may be achieved through use of the operator wearing a properly grounded wrist strap while grasping the conductive nozzle. If the alternative grounding technique is to be used, it should be documented in the work area survey.

7.5.8 Cleaning of ESDS Items.

WARNING

Isopropyl Alcohol is flammable and toxic to skin, eyes and respiratory tract. Skin and eye protection is required. Avoid repeated or pro-longed contact. Use only in well ventilated areas. Do not use synthetic wiping cloths with flammable TT-I-735 isopropyl alcohol. Keep away from open flames or other sources of ignition.

CAUTION

The camel hair brush must be wet with a 70% isopropyl alcohol or greater prior to and during cleaning of ESDS items. DO NOT use a dry brush. ESD damage to the item being cleaned may result.

- a. Exterior surfaces of assemblies or equipment containing ESDS devices may be cleaned in accordance with Chapter 2, Paragraph 2.8.
- b. Printed circuit boards/cards, wiring boards, modules and discrete parts sensitive to ESD shall be cleaned with natural bristle brushes and a 70% isopropyl alcohol or greater cleaning solution with adequate electrical conductivity (resistivity of 1×10^9 ohm-cm or less) at room temperature. Connector pins tied to ESDS circuitry shall also be cleaned using these items.
- c. Compressed air and dry nitrogen systems, without adequate filtering, that are used to blow away contaminants, or vacuum systems used to remove contaminants from ESD sensitive items shall have properly grounded

TO 00-25-234

conductive or static dissipative nozzles. Plastic or insulative nozzles have been shown to generate substantial electrostatic fields. An acceptable static dissipative vacuum is listed in Table 7-3 for use in small operations (i.e. operations where facility or "house" vacuum systems are unavailable, not cost effective to install, or cannot meet the requirements of Paragraph 7.5.7.6 Step e. This item has special inherent static dissipative attachments as referenced in Step e. The ground for this item is supplied through the power cord's 3rd wire ground. An additional grounding wire is not required on the attachments. Highly filtered compressed air or dry nitrogen systems, or compressed air/gas cans (with plastic straw nozzles) typically do not require grounded conductive nozzles, however, testing shall be conducted with a charged plate monitor for confirmation (limit - less than 100 volts in magnitude). Compressed liquid cans with plastic straw nozzles charge readily if dispensed in a liquid state. Ensure these products are not used in such a manner as to cause a liquid spray discharge.

7.6 OPERATING PROCEDURES.

The following operating procedures apply to all military organizations that handle ESDS items. All personnel shall abide by these procedures.

- a. All organizations shall assign an individual responsible for ensuring the requirements of this section of this Technical Order are met. This includes conducting work area ESD Control surveys (Paragraph 7.7) and certification of these work areas to the requirements outlined in each survey. It also includes the day-to-day operating procedures (Paragraph 7.6) and requirements necessary to effectively control ESD. For larger organizations, local operating procedures may be used to further define and distribute responsibilities. Organizational issues or conflicts related to the ESD Control requirements set forth by the organization's responsible individual shall be adjudicated by the Air Force ESD Control Technology Center. The responsible individual shall certify work areas annually through a certification evaluation. This evaluation will be the means by which the responsible individual can assure that all work areas are in compliance with the requirements of the work area ESD Control survey. The appropriate certification documents shall be completed and either posted at the entrance to the work area or in a readily accessible ESD program file.
- b. ESDS items shall only be handled outside of ESD protective packaging or non-protective packaging materials at ESD Control workstations that meet the requirements of this tech order (see Paragraph 7.5.4.1). When handling involves placement ESDS item in a remote

test fixture, environmental chamber or other place where protective packaging cannot be used, a grounded personnel wrist strap shall be worn during installation and removal of the ESDS item. Locating a proper ground point for the wrist strap for these situations shall be accomplished in a similar fashion to that of a portable ESD Control workstation (see Paragraph 7.5.6). When operating procedures necessitate the need to handle ESDS items outside of ESD protective packaging, in situations where wrist straps are not feasible, the ESDS item may be handled if the work area is equipped with an ESD flooring system (i.e., flooring, footwear, and seating).

WARNING

The personnel wrist strap shall not be worn when working on energized parts, assemblies and equipment. This requirement does not apply in situations where the powered equipment is operated normally (e.g., not opened up for maintenance, etc.), and no contact with live voltage and/or current is possible. In situations where the manufacturer recommends wearing a wrist strap on energized equipment where contact with live voltage/current is possible, the wrist strap may be worn if approval is granted from the local safety office.

- c. Portable static control workstations (Paragraph 7.5.5.4) shall be used (which includes the use of the personnel wrist strap) anytime handling and/or maintenance of ESDS items (Paragraph 7.4) is required away from the standard ESD Control workstation specified in Paragraph 7.5.5.1, Paragraph 7.5.5.2, and Paragraph 7.5.5.3. In unique situations (e.g. when performing maintenance at a console), there may be occasions when the work only requires use of an ESD Control wrist strap, typically when removal or replacement of ESD sensitive items is not required.
- d. As a minimum, personnel shall test their individual wrist straps before initial use each day in accordance with Paragraph 7.8.4. A log of the date, time, results, and user name shall be maintained for QA purposes. Wrist straps not used on a given day do not require testing that day. It is strongly recommended that each individual possess their own wrist strap and avoid sharing with other personnel. Variations in wrist size and skin conditions can lead to improper fit and wrist strap malfunction. The wrist strap cuff shall be worn snug around any portion of the arm and shall be adjusted when necessary to ensure a snug fit. However, the preferred cuff location is around the wrist.

- (1) When wrist straps are shared, the first user of the wrist strap that day shall perform this initial test. Each subsequent user shall test the functionality of the wrist strap before use.
- (2) When conducting in-flight maintenance and missile maintenance where multiple day dispatching occurs, wrist straps shall be tested prior to departure.
- (3) Dual conductor wrist straps used with continuous workstation monitors are checked continually by the monitor and do not require periodic testing per Paragraph 7.8.4.

NOTE

Some persons with extremely dry skin may find that many wrist straps will not pass periodic testing. Hand or moisturizing creams that can be tolerated by these individuals from a health standpoint can be worn to obtain better electrical continuity between the wrist strap and the wrist.

- e. ESDS items shall be transported and stored only in ESD protective packages and containers specified in Paragraph 7.5.5.14. For distribution personnel (receiving, packaging), all items with a type cargo code of "3" on the DD Form 1348-1 are ESDS and shall also be packaged in accordance with Paragraph 7.5.5.14. Marking of these packages shall be done in accordance with Paragraph 7.5.5.15.3.
- f. Static generating materials such as those listed in Table 7-1, that are not essential in conducting the work required at the ESD Control workstation, shall be removed entirely from the workstation when ESDS items are present. It is recommended that job essential static generating materials be kept at a distance of 1-foot or greater from ESDS items when possible. ESD workstations may be used by personnel even when ESD protection is not required or no ESD Sensitive items are present. In those cases, it is not necessary for static generating items to be removed, but they shall be removed (non job essential items) prior to placing an ESD sensitive item on the ESD work surface. Small stickers or markings placed in the corner of ESD control work surfaces for identification or testing purposes are permitted if desired. If an area on the ESD control work surface is marked off to identify a permanent location of a miscellaneous item, that portion of the work surface is no longer considered as part of the ESD control work surface.
- g. All personnel involved with handling ESDS items shall be given annual ESD Awareness and Prevention Training that includes familiarization with this section of the TO. Training shall be given to new personnel at initial appointment followed by annual refresher training thereafter. The student shall be tested for comprehension and understanding of ESD causes and control procedures. Training results shall be documented in personnel training records or retained in a readily accessible file.
- h. All organizations shall conduct work area ESD Control surveys in accordance with Paragraph 7.7 of this tech order. All work areas shall be surveyed to ensure that proper ESD Control products are acquired for each work area.
- i. All personnel who remove or install ESDS items in Paragraph 7.4.1.3, that are part of mission equipment (i.e. operational ground or airborne systems; for example, aircraft, missile, communications system, etc.), must be properly grounded or bonded to the item. They must also ensure that conductive caps are placed on all item connectors when these items are detached from their next higher assembly (reference Paragraph 7.5.5.14). In addition, when applicable, any cable that remains attached to an ESDS item must be capped at the detached end of the cable. This applies to cables that remain with the ESDS item being removed from the next higher assembly as well as those cables that remain attached to other ESDS items within the next higher assembly. For smaller sized items, ESD shielding bags or conductive tote boxes with lids are an option when conductive caps are unavailable. Properly capped ESD sensitive items that are relocated to a test and evaluation (or similar) facility and connected to a test station or installed as part of a test stand that performs powered diagnostic testing, shall have their ESD connector caps removed before applying power. The ESD connector caps shall be reinstalled on the item's connectors prior to removing the item from the test station or test stand.
- j. All other ESDS items described in Paragraph 7.4.1.3 that are not a constituent part of mission equipment (e.g. SE, TMDE, office/laboratory electronic equipment including computers, peripherals, etc.) do not require conductive connector caps. However, anytime these items are transported between organizations (ex., to and from PMEL), the owning organization may at their discretion, install conductive connector caps prior to transport. Receiving organization shall return equipment with conductive connector caps installed if originally received in that condition. Otherwise, personnel shall avoid direct contact with the pins of exposed external connectors at all times during normal use, transit, or storage. Strong electrostatic fields greater than 2000 volts per inch shall be kept at a distance of 1-foot

TO 00-25-234

from exposed external connectors during transit or storage. Maintenance actions shall only be performed when personnel are properly grounded or bonded to the item or at an ESD Control workstation.

NOTE

- Protective caps for standard 3 prong AC power connectors are not required.
- **OPTION 1.** If cables are connected to or disconnected from these items, personnel shall touch (with bare skin) and maintain contact with a metal portion (bare metal preferred but not mandatory) of the ESDS item's case or chassis and the cable connector backshell simultaneously while all cables are connected or disconnected. In addition, when two cables are connected, and at least one is connected to an ESDS item, personnel shall grasp the backshell of each cable prior to and during the connection process.
- Prior to removing or installing conductive caps, personnel shall touch (with bare skin) and maintain contact with a metal portion (bare metal preferred but not mandatory) of the item's case or chassis. Contact shall be maintained at all times while conductive caps are being installed or removed or work is being accomplished on the ESDS item while connectors are unprotected. In addition, any cable left connected to an ESDS item must be capped in the same fashion.
- **OPTION 2.** A ground wrist strap in accordance with Paragraph 7.5.7.3 shall be worn during all cable connecting and disconnecting operations and when conductive caps are installed or removed from these items.
- **DO NOT DISCARD** the conductive caps. Save and reuse the caps on other assemblies.

WARNING

The personnel wrist strap shall not be worn when working on energized parts, assemblies and equipment. This requirement does not apply in situa-

tions where the powered equipment is operated normally (e.g., not opened up for maintenance, etc.), and no contact with live voltage and/or current is possible. In situations where the manufacturer recommends wearing a wrist strap on energized equipment where contact with live voltage/current is possible, the wrist strap may be worn if approval is granted from the local safety office.

- k. Conductive or static shielding materials shall be used in constructing dust caps where dust caps are required for ESDS items instead of static generating materials such as those listed in Table 7-1.
- l. Work areas considered temporary vs permanent that handle ESDS items shall be surveyed per Paragraph 7.7 of this TO to determine what ESD Controls are necessary and are feasible for the temporary operation. Temporary areas consist of inside aircraft or vehicles, LFs, LCFs or areas where relocation commonly occurs.
- m. Reports of Discrepancy (ROD), (SF 364) shall be completed each time ESDS items are received in packaging materials other than those specified in Paragraph 7.5.5.14 or improperly marked and not in conformance with Paragraph 7.5.5.15. These reports shall be completed and sent to the organization(s) from which the improperly packaged items were received regardless of whether the existing packaging requirements for the items are incorrect or whether the packaging policy of the organization sent the items improperly packaged is incorrect. In cases where improperly marked or packaged items are received by distribution from a commercial vendor/contractor source, the ROD shall be sent to the responsible contracting office for resolution. This effort will aid in ensuring that proper ESD Control packaging is specified during the acquisition process and used during transport of the items.

ATTENTION STATIC SAFEGUARDED WORK AREA

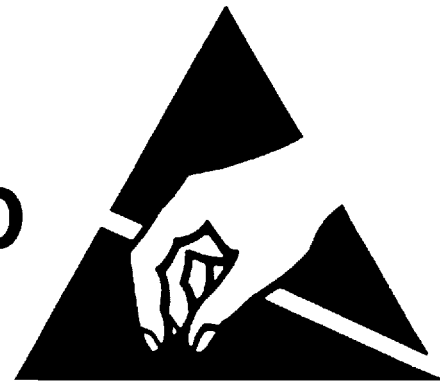

TO-00-25-234-095

Figure 7-15. Typical ESD Protective Area Sign

- n. All storage cabinets, parts bins, etc. that contain ESDS items shall be marked in accordance with Paragraph 7.5.5.15.4 of this TO.
- o. Efforts shall be made to avoid the use of Plexiglas or similar transparent, synthetic materials in the construction of cleaning, spraying, bead blasting or other booths where solvents or abrasives are propelled through gun-type nozzles where ESDS items are handled. This includes ensuring that all purchases of these types of booths include provisions for static dissipative, seethrough surfaces in lieu of Plexiglas.
- p. All ESD Control Workstation work surfaces, storage cabinets and shelves shall be tested annually in accordance with Paragraph 7.8.1, Paragraph 7.8.2. Storage cabinets and shelves used exclusively for storage of non ESDS items (or ESDS items within a complete faraday cage, ref. Paragraph 7.4.2) do not require a ground connection or periodic testing. Any work surface showing physical damage to the point where underlying layers are exposed shall be discarded and replaced at the discretion of the user. Minor damage in an area of the work surface not likely to come into contact with an ESDS device may not warrant replacement. Damage can occur to a charged ESDS device if it should come into contact with the conductive underlying layer.
- WARNING**
- Isopropyl Alcohol is flammable and toxic to skin, eyes and respiratory tract. Skin and eye protection is required. Avoid repeated or pro-longed contact. Use only in well ventilated areas. Do not use synthetic wiping cloths with flammable TT-I-735 isopropyl alcohol. Keep away from open flames or other sources of ignition.
- q. ESD Control work surfaces shall be cleaned periodically as needed with a mild soap and water mixture. There are cleaners and detergents listed in Table 7-3 that are acceptable for this purpose. Other readily available cleaning products may also be used in place of those items listed in Table 7-3. After drying, work surfaces shall be wiped with a 70 percent isopropanol-water solution using clean lint free cloth.
- r. An ESD protective area sign(s) shall be placed at or near the entrance(s) to ESD Control work areas. In areas where transient personnel are not allowed (remote missile sites) or in areas that are outdoors (flight-lines) the awareness sign is not necessary. The sign is intended primarily for depots, PMELS, etc. Figure 7-15 shows what a typical awareness sign might look like.
- s. Any wheeled metallic carts used in areas having ESD Control flooring shall have a metal drag chain installed on the bottom (riveted to the cart's metal chassis) to provide electrical continuity from the cart to the flooring.
- t. Persons working at ESD Control workstations where circuit board, wiring board or module repair is done shall roll up their shirt sleeves above the elbow prior to and during repair, handling or inspection of these items.
- u. Access to certified ESD Control work areas shall be limited to properly trained personnel. Visitors shall be allowed in these areas only after being briefed on proper procedures to be followed while in the area and only when escorted by a trained employee. Visitors are exempt from static dissipative footwear requirements, however, visitors shall wear a properly grounded wrist strap if they are involved with the handling of ESDS items.
- v. Static dissipative seating, shoes and flooring shall be performance tested annually in accordance with Paragraph 7.8.3, Paragraph 7.8.4, Paragraph 7.8.5. and Paragraph 7.8.7.

TO 00-25-234

- w. Bench top ionizers shall be tested quarterly for performance in accordance with Paragraph 7.8.6.
- x. Grounds for ESD Control workstations and computer keyboard ground strips shall be verified when installed, relocated and annually thereafter in accordance with Paragraph 7.5.6 If computer keyboard ground strips are cracked or broken they shall be replaced.
- y. If the ESD Control products (Paragraph 7.5.6) required per the work area ESD Control survey (Paragraph 7.7) and this TO conflict with specific item TOs, an AFTO Form 22 shall be submitted requesting the specific item TO be changed, via operational supplement to include the requirements of this TO.
- z. Areas utilizing static dissipative flooring shall not wax or apply any topical coatings of any kind that inhibit the static dissipative properties of the floor. Use only manufacturer suggested ESD cleaners, polishes, and conditioners, following prescribed application procedures. If there are no manufacturer suggested cleaners or conditioners, clean the floor using mild soap and water, ensuring no residue remains. Never apply standard floor wax to static dissipative flooring.
- aa. All solder guns or irons shall be tested quarterly to ensure that the tip is electrically connected to the equipment grounding conductor in the units plug. A periodic test procedure is included in Paragraph 7.8.11.
- ab. Ensure all compressed air, hot air blowers, dry nitrogen or vacuum nozzles used to clean ESDS items are inherently static dissipative or conductive and properly grounded in accordance with Paragraph 7.5.7.6 Step e. Conductive grounds shall be checked annually in accordance with Paragraph 7.8.12.
- ac. ESDS items designated for disposal/destruction are exempt from ESD protection requirements once that decision is finalized.
- ad. When using hand tools with conductive tips at an ESD control workstation, best practice is to either momentarily touch the tip of the tool to the ESD work surface or momentarily touch (with bare hand) the tip of the tool while wearing a properly grounded ESD wrist strap to dissipate static charges from the conductive tool prior to use.

Table 7-5. Summary of ESD Periodic Testing Time Intervals

Item	Test Paragraph	Periodic Test Interval
Work Surfaces	Paragraph 7.8.1	365 days
Storage Cabinets and Shelves	Paragraph 7.8.2	365 days
Flooring	Paragraph 7.8.3	365 days
Wrist Straps	Paragraph 7.8.4	Before initial use each day. See also Paragraph 7.6 Step d
Footwear	Paragraph 7.8.5	365 days
Bench Top Electrical Ionizers	Paragraph 7.8.6	90 days
Seating	Paragraph 7.8.7	365 days
Shielding Bags	Paragraph 7.8.8	Before each use.
Conductive/Static	Paragraph 7.8.9	N/A
Dissipative Finger Cots		
Workstation Grounding and Computer Keyboard	Paragraph 7.8.10	When installed, relocated, or every 365 days
Ground Strips		
Solder Guns or Irons	Paragraph 7.8.11	90 days
Compressed air, Dry Nitrogen and Vacuum Nozzles	Paragraph 7.8.12	365 days

7.7 WORK AREA ESD CONTROL SURVEYS.

If the surveyor is performing a survey within a distribution, storage, or packaging area, the rules for determining whether items are handled as ESD sensitive are basically the same.

Most discrete parts received, stored or handled within these areas have NSNs and can be easily referenced to Paragraph 7.4.1.1. For circuit boards handled in these areas it would be best to conduct the survey under the assumption that they are all sensitive to ESD. It follows then, that “black boxes”,

SRUs, LRUs, end items, etc. containing these boards are also ESDS and the area shall be equipped accordingly.

7.7.1 Background. Work area ESD Control surveys will set up procedures to determine the level of ESD Control required in a given work area. This portion of this section provides requirements necessary to conduct such surveys.

7.7.2 General. Specific ESD Controls necessary in one area may not be the same as those required in another area. A work area ESD Control survey allows an ESD responsible person (see Paragraph 7.6 Step a) or team of experts to dictate the level of ESD Control essential in each area.

7.7.3 Performing Work Area ESD Control Surveys. The first step in an ESD Control Survey is to define the work area (flightline, hangar, avionics shop, depot repair room, etc.). Then determine whether ESD sensitive items are handled in the work area (reference Paragraph 7.4.1). The surveyor shall concentrate on the discrete parts handled in the work area first. A list of ESDS items should be in the applicable equipment TO. If the list is not in the TO, a list can be obtained from the assigned equipment specialist (see Paragraph 7.4.1.1). If no such lists are available, use visual inspection of parts or bench stock and the guidelines given in Paragraph 7.4. Distribution data bases can also be used. Stock classes called out in Paragraph 7.4 are for discrete parts.

NOTE

Next, the surveyor shall determine the types of ESD Control products necessary for the work area. The surveyor may also note how any unique ESD Control procedural requirements will be handled in the work area. A written ESD Control work area survey shall be prepared and distributed accordingly. A copy shall be kept in a readily accessible file.

7.7.4 ESD Control Product Requirements. Two basic rules are used in determining what and how many controls are required:

Rule 1: Handle all ESDS items at an approved static controlled workstation. This workstation shall be capable of controlling static on all things by grounding all conductors, including people. It shall also utilize bench top air ionization (when necessary per Paragraph 7.7.4.7.2) to neutralize static charge on all non-conductors.

Rule 2: Transport and store all ESDS items (both reparable and serviceable) in static shielding (Faraday Cage) and noncharge generating packages or containers. These packages or containers are capable of protecting the inner contents against static fields and discharges. They are also constructed so that the interior surface contacting the packaged item is resistant to the generation of static charge.

Paragraph 7.7 provides requirements for selection of the proper package or container for in-house and off-base transportation applications. Both reparable and serviceable ESDS items require protective packaging. Reparables require it to prevent further ESD damage from being done to the remaining operative parts. Paragraph 7.5.5.14 provides the requirements of ESD protective packaging materials. In the case of whole systems containing ESDS items this static shield may be its metallic frame or shell as long as electrical leads to the outside world are properly capped with conductive materials. When conductive ESD connector caps are not required, personnel shall avoid direct contact with the pins of exposed connectors and strong electric fields greater than 2000 volts per inch shall be kept at a distance of 1-foot from these connectors during transport or storage.

NOTE

ESD connector caps are not required for all applications (reference Paragraph 7.6 Step i).

7.7.4.1 The following ESD Control products are described for the surveyor's benefit. As stated, the surveyor will determine which of these items are necessary for the work area being surveyed. NSNs and/or part numbers for the ESD Control products specified herein are listed in Table 7-3. Only products qualified through the Air Force ESD Control Technology Center included in Table 7-3 may be used in Air Force facilities. Use of a substitute item may only be authorized by the Air Force ESD Control Technology Center.

7.7.4.2 Static Control Workstations. A basic static control workstation consists of three components: an adjustable wrist strap cuff and ground cord, a common point ground system, and a static dissipative work surface. Paragraph 7.5.4.1 provides a more detailed description of each workstation and the components thereof. Continuous workstation monitors are an optional requirement and may be used if the surveyor so desires. The surveyor shall walk through and observe the work area with the help of the area supervisor or someone familiar with the operations within the area and determine the number of workstations where repair or handling of ESD Sensitive items occurs. He/she then decides which of the 4 types of workstations shall be used for the various handling or repair operation and shall annotate the number of each.

7.7.4.3 Test Benches. Test benches or areas where ESD Sensitive parts, circuit boards, assemblies and systems containing ESDS items are electrically tested for functionality will require ESD Control workstations. Benches used to perform go/no go testing only on shielded systems do not require ESD Control workstations. Grounding in accordance with Paragraph 7.6 Step i must still be achieved when connecting/ disconnecting and capping or uncapping systems. Work surfaces may be required to be odd shaped to conform to the shape of the working area associated with each unique

TO 00-25-234

test set. In these cases the surveyor can require that 40 foot lengths of cushioned static dissipative work surface material be purchased by the work area and cut to conform to the working area around each test station. For test stations where the item under test containing ESDS items is distant from the test console, there shall be a female wrist strap connector (banana jack), properly grounded, at the test location. It is common for technicians to open the item under test and remove faulty parts. The surveyor shall require that a wrist strap be worn when these operations take place. Bench top ionization is not required during a test operation.

7.7.4.4 Wrist Straps. The wrist straps may be required as a stand alone ESD Control item as described in Paragraph 7.6 Step i and Paragraph 7.7.4.3. The surveyor shall determine what operations within the area meet these requirements. Paragraph 7.5.5.5 provides a more detailed description of the components of the personnel wrist strap.

7.7.4.5 Unique Situations. At this point the surveyor has determined the number, location and type of ESD Control workstations that are required for the work area for all test, repair, handling and storage operations. Unique situations may occur and should be handled as follows:

7.7.4.5.1 Spray/cleaning Booths and Flush and Conformal Coating Stations. Spray booths and flush and conformal coating stations used to clean or flush ESDS parts or assemblies shall have a female wrist strap connector (banana jack) connected in accordance with Paragraph 7.5.7.3 so that the operator can ground his/herself via a wrist strap when performing cleaning or coating operations. Nozzles used with compressed air or dry nitrogen shall conform to Paragraph 7.5.8 Step c.

7.7.4.5.2 Ovens, Temperature Cycling Stations. Ovens or temperature cycling stations used to cure coatings or temperature soak ESDS parts or assemblies shall be equipped with a properly grounded (see Paragraph 7.5.7.3) female wrist strap connector (banana jack), to ground the operator via a wrist strap when installing or removing the ESD Sensitive items.

7.7.4.5.3 Soldering Guns or Irons. All soldering guns or irons shall meet the requirements listed in TO 00-25-259 when soldering on or around ESDS items.

7.7.4.6 Packaging marking and storage of ESDS items.

7.7.4.6.1 Whenever an ESD Sensitive item(s) is transported between workstations, work areas or between installations it shall be placed in properly closed static control packaging and marked accordingly. The surveyor shall determine what packaging and marking requirements are necessary for the area being surveyed based on requirements given in Paragraph 7.5.5.14 and Paragraph 7.5.5.15 of this document.

7.7.4.6.2 The surveyor shall require that any cabinet, bin or shelf used for storage of ESDS items within the work area be grounded. ESDS discrete parts/IC's that have all leads shunted together through use of ESD Control conductive foam or wire shall be considered non-sensitive. As such, these items may be stored locally in-house outside of ESD Control packaging or conductive tote boxes. This does not apply to items transported from base to base, to/from a contractor's facility or cross country (reference Paragraph 7.5.5.14.2 Step d). Also remember that items contained within a complete faraday cage per Paragraph 7.4.2 are not ESDS. The surveyor can however, determine whether the packages containing the items will be opened regularly at the cabinet. In these cases cabinets and shelves must be grounded. He/she shall ensure that when the shelves of the cabinets or bins are grounded, the shelves, if painted, are electrically resistance checked to ensure the surface of each shelf is not above 1 x 10⁹ ohms. If the resistance is higher than this value, the shelves must be fitted with static dissipative (1 x 10⁶ to 1 x 10⁹ ohms) matting that is electrically connected to an acceptable ground point. The surveyor shall require that these storage cabinet alterations be made if necessary. If the area being surveyed is new, then new static dissipative storage cabinets with the above properties shall be procured. If multi-packs are stored in, and opened at these cabinets, a personnel wrist strap ground connection (verified per Paragraph 7.5.6) and proper packaging per Paragraph 7.5.5.14 shall be incorporated.

7.7.4.6.3 The surveyor shall identify areas within the work area where discrete ESDS parts are stored and require that ESD Caution labels be applied to the front of each part compartment making them easily visible to personnel obtaining the parts. Information on these labels can be found in Paragraph 7.5.5.15.4 of this TO.

7.7.4.7 Other work area survey requirements.

7.7.4.7.1 Wrist Strap Testers. The surveyor shall determine the number of testers required in a work area, and the location of those testers. The surveyor shall ensure that sufficient testers are available to perform the necessary checks of wrist strap functionality. Preferably the tester(s) shall be mounted in a visible location, approximately eye level, with instructions for use on a placard next to it. If necessary, the tester(s) may be located at an alternate location (e.g., desktop, etc.) suitable to meet the needs of each particular work area. As a minimum, personnel test their individual wrist straps before initial use each day (see Paragraph 7.6 Step d for details). Dual conductor wrist straps used with continuous workstation monitors are checked continually by the monitor and do not require a wrist strap tester.

7.7.4.7.2 Bench Top Ionization. Bench top ionization is an additional ESD Control requirement that shall be required by the work area surveyor if all of the following conditions apply:

- a. The work area conducts board level repair (remove/replace ESDS discrete parts) on a routine basis (weekly).
- b. Job essential charge generating materials are present at the workstation and the job procedure requires them to be closer than 1-foot from ESDS items.
- c. The ESDS items being repaired are a constituent part of a major weapon system (e.g. aircraft, missile, communications system, etc.)

7.7.4.7.2.1 The ESD responsible person may optionally require bench top ionization if the determination is made that bench top ionization is necessary for the work area and cost effective to do so.

7.7.4.7.3 Humidity Levels. Although increased humidity levels in areas that handle ESDS items may decrease the amount of static charge found on personnel or items in the area, it may also give those in the work area a false sense of security that all ESD problems are gone. The fact is that these decreased static levels can still destroy the ESDS circuitry being handled. The surveyor shall handle the humidity issue as follows:

- a. If steam generating equipment and air handlers already exist in the work area and levels of humidity between 40 and 60 percent can be achieved then it shall be required as part of the work area ESD Control survey.
- b. If the work area is new with no capability to regulate humidity levels or is an older area that never had humidity regulating capabilities then the additional investment in such equipment is not necessary. The surveyor shall state that all other static control procedures and products required as part of the work area survey will adequately provide ESD protection.

7.7.4.7.4 ESD Awareness and Prevention Training. ESD Awareness and Prevention Training is required for all personnel involved with handling ESD sensitive items (refer to Paragraph 7.6 Step g). The ESD responsible person may contact the AF ESD Control Technology Center for additional information.

7.7.4.7.5 Static Dissipative Floor System. A static dissipative floor system (Paragraph 7.5.5.9), is an additional ESD Control requirement that shall be required by the work area surveyor if all of the following conditions apply:

- a. New flooring is to be installed or the work area plans to replace existing flooring.
- b. The work area handles ESDS (Paragraph 7.4.3) items on a routine basis (weekly).

- c. Operations routinely require transporting ESDS items between multiple workstations within the same work area.

7.7.4.7.6 The ESD responsible person may optionally require a static dissipative floor system if the determination is made that the work area can take advantage of the benefits of the ESD Control flooring system.

7.7.4.7.7 If the surveyed area requires static dissipative flooring per the guidelines mentioned above, then static dissipative footwear and seating shall be required (see Paragraph 7.5.5.9.1, Paragraph 7.5.5.9.2, and Paragraph 7.5.5.9.3). Standard military footwear may be used in lieu of static dissipative footwear when required by local policy or job function.

7.7.4.7.8 Finally if the area requires static dissipative flooring, and wheeled push carts are used in the area, the surveyor shall require the carts to have electrical continuity to the floor. A drag chain is required to be fastened to the base metal of the cart and long enough to touch the floor.

7.7.4.7.9 Conductive Or Static Dissipative Gloves/Finger Cots. The surveyor shall require as part of the work area ESD Control survey that charge generating latex finger cots and gloves be removed from the work area and static protective ones be obtained if ESDS items are handled (see Paragraph 7.5.5.8).

7.7.4.7.10 Computer Keyboard Ground Strips. Computer keyboard ground strips are no longer an ESD Control requirement for new (modern) keyboards (see Paragraph 7.5.5.12) brought into an ESD work area. Existing computer keyboards previously identified in a work area survey and installed with computer keyboard grounding strips shall remain so equipped. In general, keyboards made primarily of plastics (i.e., exterior keys and chassis) are generally immune to human body ESD events. It is the discretion of the surveyor to make the determination as to whether a keyboard grounding strip or other device is required. If the area is equipped with a static dissipative flooring system (Paragraph 7.5.5.9) or if the computer is equipped with a personal wrist strap, the keyboard ground strips are not required. This requirement is only for computer equipment which support a weapon system.

7.7.4.7.11 Work Area ESD Control Survey Reports. The numerous requirements for effective ESD Control for any work area as explained in this section of the TO shall be summarized in an official report that can be distributed to all management and area support personnel who will play a role in fulfilling the survey requirements. The surveyor shall reference this report when attempting to certify the work area in accordance with Paragraph 7.6 Step a. The survey and certification documents may be combined into a single docu-

TO 00-25-234

ment if desired, and may be in any format as determined by the ESD responsible person unless otherwise directed by a local operating instruction.

7.7.5 Work Area ESD Control Checklist. The following checklist can be used by the surveyor to aid in conducting work area ESD Control surveys.

- a. Is a work area ESD Control survey required? Requirement is established by the ESD responsible person or work area supervisor. Local policy may already dictate who determines whether a survey is required.
- b. Are ESDS items handled in the work area? Sources used to determine this are:
 - * Equipment TOs.
 - * Correspondence from equipment specialist.
 - * Qualified Product Databases (QPD) for MIL-PRF-38535 and MIL-PRF-19500, or base supply data system (Type Cargo Code “3” items).
 - * Inspection of parts or bench stock bins for items that are in the FSCs outlined in Paragraph 7.4.1.
- c. Designate individuals to participate on the “survey team”. As a minimum, it consists of the ESD responsible person and the work area supervisor.
- d. Define the work area. This may be a complete facility, a room, or a single workstation. It may also be defined by an operation (i.e. test, repair, storage, etc.) within a room or facility. This is determined by the survey team.
- e. Procedures for conducting a work area ESD Control survey.

NOTE

The survey team shall identify which of the following ESD Control measures or items are required for the work area. When appropriate (e.g. workstations, wrist straps), determine minimum quantities required. For other items such as ESD shielding bags, labels, or other similar items, stock

the area with sufficient quantities for the anticipated workload.

- * Workstation(s) (Paragraph 7.5.4.1 and Paragraph 7.7.4.2).
 - * Wrist strap(s) (Paragraph 7.5.5.5).
 - * Common Point Ground System(s) (Paragraph 7.5.5.6).
 - * Continuous Workstation Monitor(s) (optional, see Paragraph 7.5.5.1).
 - * Approved grounding point(s) (Paragraph 7.5.6) for CPGS(s) or Continuous Workstation Monitor(s).
 - * Wrist strap tester(s) (Paragraph 7.7.4.6.2).
 - * Storage Cabinets, bins, shelving (Paragraph 7.7.4.6.2).
 - * Packaging and marking of ESDS items handled in the work area (Paragraph 7.7.4.6).
 - * Restricted access (Paragraph 7.6 Step u).
 - * ESD protected area signs posted (Paragraph 7.6 Step r).
 - * Unnecessary static generators removed (Paragraph 7.6 Step f).
 - * Computer keyboard ground strips (Paragraph 7.7.4.7.10).
 - * Static dissipative gloves or finger cots (Paragraph 7.7.4.7.9).
 - * Soldering irons in accordance with Paragraph 7.6 Step a.
 - * Bench top ionizers (Paragraph 7.7.4.7.2).
 - * Static dissipative floor system (Paragraph 7.7.4.7.5).
 - * Humidity control (Paragraph 7.7.4.7.3).
- f. Ensure steps are taken to update specific item technical orders to include ESD Control Procedures outlined in this TO.
 - g. Ensure that all personnel who will be involved with handling ESD sensitive items receive ESD Awareness and Prevention Training.
 - h. A written “ESD Control Work Area Survey” shall be distributed accordingly.

7.8 PERIODIC TESTING OF ESD CONTROL PRODUCTS.

Periodic testing of items or materials used to control ESD is required. Refer to Table 7-5 for summary of Periodic Testing Time Intervals. For each of the test paragraphs listed below (excluding ESD Shielding Bags and conductive/static dissipative finger cots and gloves), documentation of results shall be maintained for QA purposes.

7.8.1 Work Surface Test Procedures.



If a line (AC) powered Megohmmeter is used to measure the resistance of a grounded item, an alternate test lead setup may be required from what is stated in the following paragraphs. Refer to the manufacturer's instruction manual for the proper setup and measurement of grounded items. On some line powered Megohmmeters this includes removing the shunt between the chassis ground terminal and the signal ground terminal, shorting signal high to chassis ground, connecting the positive (signal high) lead to the ground point of the item under test and connecting the negative lead to your measurement point. Erroneous measurements may result due to ground loops present when the chassis ground terminal is shunted to the signal ground terminal.

Work surface test procedures (required whether or not continuous monitors are used). The test equipment required to do work surface testing is specified in Paragraph 7.5.5.13.5.

- a. The work surface shall be tested in its existing environment.
- b. All resistance measurements shall be taken 5 seconds after applying test voltage (100 volts).
- c. Connect the positive lead from the megohmmeter to one of the five lb. electrodes and the negative lead to the common point ground. Place the electrode near the rear edge of the work surface and approximately 36 inches from the common point ground. Apply test voltage of 100 volts.
- d. Take reading and record. Repeat procedure placing the electrode in the center of the work surface and again near the forward edge of the work surface. Total resistance from top of work surface to ground point for each measurement shall be between 1×10^6 and 1×10^9 ohms.

WARNING

Isopropyl Alcohol is flammable and toxic to skin, eyes and respiratory tract. Skin and eye protection is required. Avoid repeated or pro-longed contact. Use only in well ventilated areas. Do not use synthetic wiping cloths with flammable TT-I-735 isopropyl alcohol. Keep away from open flames or other sources of ignition.

- e. If the measurements taken do not fall within the specified range, clean the component being tested with a 70 percent isopropanol-water solution using a clean lint free cloth. Repeat Step d.
- f. If the measurements taken still do not fall within the specified range the work surface shall be discarded and replaced.

7.8.2 Storage Cabinet and Shelf Test Procedures. The test equipment required to test shelves, cabinets, and storage units is specified in Paragraph 7.5.5.13.5.

NOTE

Storage cabinets and shelves used exclusively for storage of non ESDS items (or ESDS items within a complete faraday cage, ref. Paragraph 7.4.2) do not require a ground connection or testing.

- a. All shelves, cabinets, and storage units shall be tested in their existing environment.
- b. All resistance measurements shall be taken 5 seconds after applying test voltage (100 volts).
- c. Connect the positive lead from the Megohmmeter to a five lb. electrode and the negative lead to the ground point of the item under test. Place the electrode on a shelf/drawer and apply the test voltage (100 volts). Measure and record the resistance reading. Repeat this process to obtain a total of three measurements (one measurement for three different electrode positions) on this shelf/drawer. Calculate and record the average of the three resistance measurements. Repeat this process for each shelf/drawer to be tested. The average resistance for each shelf/drawer shall be between 1×10^6 and 1×10^9 ohms.
- d. If the measurements taken do not fall within the specified range, clean the component being tested with a 70 percent isopropanol-water solution using a clean lint free cloth. Repeat Step c.

TO 00-25-234

- e. If the measurements taken still do not fall within the specified range the components shall be discarded or covered with a material that meets the prescribed resistance.

7.8.3 Flooring Test Procedures. The test equipment required for testing installed flooring is specified in Paragraph 7.5.5.13.5.

- a. Flooring shall be tested in it's existing environment and normal state of cleanliness.
- b. All resistance measurements shall be taken 5 seconds after applying test voltage (100 volts).
- c. The installed floor shall be subjected to surface to ground resistance measurements using the specified megohmmeter and electrode. The applied open circuit test voltage shall be 100 volts for each measurement.
- d. **RAISED FLOORS:** Remove a panel from the floor and connect the negative lead from the Megohmmeter to an installed pedestal beneath the floor. Connect the positive lead of the Megohmmeter to a five lb. electrode. Place this electrode onto an adjacent panel to the one that was removed above. Apply the test voltage (100 volts) and measure and record the resistance measurement. Repeat for each measurement taken.

(1) A total of 16 equally spaced resistance measurements shall be taken for every 10,000 square foot area of flooring. For floors with less than 10,000 square feet one resistance measurement shall be taken for each 400 square feet of flooring (equally spaced). The average of the total surface to ground resistance measurements shall be between 1×10^6 and 1×10^9 ohms with no individual measurement being above 5×10^9 or below 1×10^6 ohms.

(2) If the floor fails to meet these specifications the floor shall be thoroughly cleaned in accordance with the manufacturers recommendations and retested as per Paragraph 7.8. Step e and Step f.

(3) If the floor still fails to meet these specifications, verify the calibration of the megohmmeter and retrieve the initial installed floor test results. Compare test results and determine if the readings are higher or lower than the initial readings. If higher, this may suggest that the floor has been waxed or coated. Take steps to determine if this is the case. If so, the floor must be stripped and recleaned before retesting. If the readings are lower, a coating still may have been added, but with conductive properties. Again, stripping and recleaning will be necessary. These procedures should bring the floor within the specified resistance range.

- e. **OTHER FLOORS:** The resistance measurement procedure is the same as for raised floors with the exception

that the negative lead from the ohmmeter is connected to a point electrically the same as one of the acceptable points at which the floor is grounded. The number of test points, specified resistance range and retest processes are as specified in Step d(1), Step d(2), and Step d(3).

7.8.4 Wrist Strap Test Procedures.**NOTE**

Dual conductor wrist straps used with continuous workstation monitors are checked continually by the monitor and do not require testing per this paragraph.

Test equipment required for testing wrist straps is a wrist strap tester as specified in Paragraph 7.5.5.13.2.

- a. **Battery Check:** For battery powered wrist strap testers, follow the manufacturers operating instructions for procedures to check/service the battery.
- b. The wrist strap shall be tested while being worn. Put on the wrist strap cuff (band) with ground cord attached. Adjust the wrist strap cuff if necessary to ensure a snug fit.
- c. Insert wrist strap banana plug into the banana jack on the wrist strap tester. Using either hand, press and hold the metal contact plate until the green or red pass/fail light illuminates and remains illuminated.

NOTE

Some wrist strap testers may use the terminology "OK/NOT OK" in place of "pass/fail".

- d. Observe the pass/fail indicator lights. If the green (pass) light is illuminated the wrist strap and cord are both good and you have successfully passed this test. If the red (fail) light is illuminated, proceed to the next paragraph if the wrist strap tester is equipped with a ground cord wrist snap fastener, otherwise proceed to Step f.
- e. Disconnect the wrist strap cord from the cuff and snap the cord onto the snap fastener of the wrist strap tester. Hold the banana end of the cord with the bare hand and press and hold the metal contact plate with the opposite hand. Continue to hold the banana end and metal contact plate until one of the pass/fail lights illuminates and remain illuminated, then proceed to Step g.
- f. Disconnect the wrist strap cuff from the cord and place the metal side of the ground cord snap against the tester's metal plate. Press the ground cord snap being

careful that only the ground cord snap (not the person) is in contact with the tester's metal plate. Wait until one of the pass/fail lights illuminates and remains illuminated.

- g. If the red (fail) light is illuminated, discard the ground cord and repeat Paragraph 7.8.4 using a new ground cord.

NOTE

An alternative ground cord check can be accomplished by using an ohmmeter (Reference Paragraph 7.5.5.13.6) to measure the resistance from the ground cord banana jack to the ground cord snap end. A good ground cord will have a resistance of 1 Megohm $\pm 20\%$. If the ground cord is good, proceed with the next paragraph assuming a green (passing) condition.

- h. If the green (pass) light is illuminated, discard the cuff and repeat Paragraph 7.8.4 using a new cuff.

NOTE

In some cases, high contact resistance between the person's skin and wrist strap cuff (band) will cause a fail condition. This resistance may be caused by excessive dry skin or excessive hair in the wrist area. If these conditions do not exist with the person then the cuff should be discarded. Hand or moisturizing creams that can be tolerated by the individual can be worn to obtain better electrical continuity between the wrist strap cuff and the wrist.

- i. A log of the date, time, results, and user name shall be maintained for QA purposes. Refer to Paragraph 7.6 Step d.

7.8.5 Footwear Test Procedures. Footwear Test Procedures are as follows:

- a. Shoes will be replaced on an as needed basis determined by wear and condition of shoe in general.
- b. Shoes shall be lab tested by random sampled lots annually. The test method and resistance specification can be obtained from the ESD Control Technology Center at AFRL/RXSA.

7.8.6 Test Procedures for Bench Top Electrical Ionizers. The test equipment required for testing bench top electrical ionizers is specified in Paragraph 7.5.5.13.8. A standard measuring tape (minimum 6 ft) and air velocity measuring meter (ft/min) are also required.

- a. The ionizer shall be tested in its existing environment with the heater off, if so equipped. The ionizer shall be tested with filters in place, if so equipped, and at a maximum air flow rate of 600 FPM. The air velocity shall be measured and recorded in the test results.

b. Discharge Time Test

- (1) Place the charge plate monitor directly in front of the ionizer with the plate parallel to the front face of the ionizer at a distance of one foot.
- (2) Turn the ionizer on, wait 30 seconds, charge the plate to +1000 volts and allow it to discharge to +100 volts. The charge plate monitor will measure the time it takes to discharge. Record the discharge time. Repeat procedure for -1000 volts. The discharge time for both the + and - initial plate voltages shall be less than three (3) seconds.
- (3) Repeat Paragraph 7.8.6 Step b(1) and Step b(2) for plate to ionizer distances of 2 and 3 feet. The discharge times for these distances shall be 6 seconds and 10 seconds, respectively.
- (4) If the voltages do not discharge in the specified time clean and balance the ionizer in accordance with the manufacturers instructions.
- (5) Repeat Paragraph 7.8.6 Step b(1) and Step b(2).
- (6) If the voltages still do not discharge in the specified time limit the ionizer shall be discarded.

c. Offset Voltage Test.

- (1) Place the charge plate monitor in front of the ionizer and oriented as specified in Step b(1). The distance between the plate and the ionizer shall be six (6) inches.
- (2) The plate shall be momentarily grounded to remove any residual charge and to verify zero of the monitor's circuitry.
- (3) Turn the ionizer on and allow it to operate for one (1) minute, or as necessary to allow reading to stabilize (maximum five (5) minutes). Record the plate voltage. The voltage shall not exceed 20 volts.
- (4) If the measurement exceeds the maximum of 20 volts, follow manufacturers instructions for ion balancing. If the unit is self balancing or has no ion balancing ability the unit shall be discarded.

TO 00-25-234

- (5) After balancing, repeat Paragraph 7.8.6 Step c(1), Step c(2), and Step c(3).
- (6) If the measurement still exceeds the maximum of 20 volts the unit shall be discarded.

7.8.7 Seating Test Procedures. The equipment required for testing seating is as specified in Paragraph 7.5.5.13.3. A non-anodizing, 3 inch x 6 inch, flat metal sheet (min 1/16 inch thick) is also required as a test electrode.

- a. Seating shall be tested in it's existing environment. Do not clean the chair. Remove only those items that might interfere with the test.
- b. All resistance measurements shall be taken five (5) seconds after applying test voltage (100 volts).
- c. The resistance of each tested seat shall be between 1×10^6 and 1×10^9 ohms.
- d. Place one caster on top of the 3 inch x 6 inch electrode assuring that the electrode is clean (no oxidation). Place one of the 5 lb. electrodes from the test kit on the 3 inch x 6 inch electrode.
- e. Place the other 5 lb. electrode from the test kit in the middle of the seat. Assure that the contact surface of the electrode is clean (no oxidation).
- f. Connect the positive lead from the megohmmeter to the 5 lb. electrode that is on the seat. Connect the negative lead from the megohmmeter to the 5 lb. electrode that is on the 3 inches x 6 inches electrode.
- g. Apply test voltage and record the resistance value.
- h. Repeat Paragraph 7.8.7 Step d, Step e, Step f and Step g for all casters.
- i. If the measurement does not fall within the specified range, disconnect the negative lead from the 5 lb. electrode on the 36 X 36 inch electrode and connect it directly to a metal point on the seat base. Reapply the test voltage and record the resistance value.

WARNING

Isopropyl Alcohol is flammable and toxic to skin, eyes and respiratory tract. Skin and eye protection is required. Avoid repeated or pro-longed contact. Use only in well ventilated areas. Do not use syn-

thetic wiping cloths with flammable TT-I-735 isopropyl alcohol. Keep away from open flames or other sources of ignition.

- j. If the measurement in Step h falls within the specified range, clean the casters of the seat thoroughly with a 70 percent Isopropyl Alcohol and water solution using a clean lint free cloth. Allow to air dry.
- k. Repeat Paragraph 7.8.7 Step d, Step e, Step f and Step g. If the reading is still outside the specified range, replace the casters.
 1. If the seat still does not meet the resistance requirement after changing the casters, replace the seat.

7.8.8 Shielding Bag Test Procedures. A visual inspection of shielding bags will be accomplished prior to each use. If the bag is torn or ripped it will be discarded.

7.8.9 Conductive/Static Dissipative Finger Cots and Gloves. No reuse is allowed. Discard after each use.

7.8.10 Workstation Grounding Test Procedures. Workstation grounding shall be tested in accordance with the procedures outlined in Paragraph 7.5.6.

7.8.11 Solder Gun or Iron Test Procedures. Equipment Required. The equipment required for testing solder guns or irons is as specified in Paragraph 7.5.5.13.6.

- a. If the soldering iron is at operating temperature, thoroughly clean and tin the soldering iron's tip.
- b. The solder gun or iron shall be tested in its existing environment. Unplug and allow iron to cool before handling.
- c. Connect or contact leads of the ohmmeter to the tip of the solder gun/iron and the equipment grounding conductor (round) or third wire of the items plug.
- d. The measured resistance shall be less than 20 ohms.
- e. If the measurement exceeds 20 ohms, clean or replace the solder iron/gun tip and remeasure.

NOTE

Thoroughly clean and tin the soldering iron tip. Be sure the solder tip or element is screwed into the handle securely.

7.8.12 Compressed Air, Hot Air Blowers, Dry Nitrogen and Vacuum Nozzle Ground Test Procedures. The equipment required for testing the nozzle is as specified in Paragraph 7.5.5.13.6.

- a. Except as noted below, connect or contact the positive lead of the ohmmeter to the nozzle tip and the negative lead to an equipment ground conductor (third wire) as defined in Paragraph 7.5.6, or to a nearby ESD Control Workstation ground.

NOTE

For item 197, Table 7-3, connect the positive lead of the ohmmeter to the metallic contact located at the vacuum inlet and the negative lead to the power cord's third wire ground.

- b. The measured resistance shall be less than 1×10^6 ohms.

CHAPTER 8

FRONT PANEL REPAIR

8.1 GENERAL.

The repair procedures outlined in this chapter will be used to the extent of the skill level of personnel assigned and support equipment normally authorized. This Technical Order will not be used as a justification for requesting the addition of support equipment to Table of Allowances. The extended life of several weapon systems has made it economical to repair system front panels which were previously not repairable. This chapter describes the tools and techniques generally used in the maintenance and repair of front panels. It contains a brief discussion of front panel classification, manufacturing techniques, a listing of repair tools and accessories, materials, general precautions, and troubleshooting techniques. It describes cracked panel repair, broken corner repair, buss wire repair, bulb replacement, silkscreening and painting techniques.

8.2 TYPES OF FRONT PANELS.

Front panels are constructed from one plastic sheet of transparent acrylic material conforming to all requirements of specification MIL-P-5425. Most panels are finished with black epoxy ink as the front face background and are illuminated red, blue, green or yellow. The markings on the panels are finished with white epoxy ink. Front panel markings indicate operation parameters of a particular system.

8.2.1 Exterior Lighted Front Panels. Exterior lighted front panels utilize MS25010 light assemblies for illumination. This type of panel is not used for new design, however, the repair procedure in the following paragraphs is consistent with all types of panels.

8.2.2 Illuminated Front Panels. Illuminated front panels are lighted by replaceable lamps and wiring embedded in the panel, with the panel containing all lampholders using wiring and connectors or use encapsulated electroluminescent or incandescent lamps or both.

NOTE

Special tools and consumable materials required for maintenance of front panels are listed in Table 8-1. Equivalent items may be used if the recom-

mended items not available. Cleaning, inspection, testing and repair procedures are contained in the following paragraphs.

8.3 TOOLS AND ACCESSORIES.

Set Table 8-1 for tools and accessories or their equivalent required for repairing or manufacturing illuminated front panels. Refer to Figure 8-7 for details on special Front Panel Mold.

8.4 MATERIALS.

See Table 8-2 for materials or their equivalent required for repair or manufacturing of illuminated front panels.

8.5 GENERAL PRECAUTIONS.

The following general precautions should be observed during maintenance and repair of front panels.

- a. Avoid excessive flexing of front panels which could crack or break the acrylic plastic.
- b. Exercise care in removing and installing front panels into panel mold as undue pressure will break or crack the front panel.
- c. Exercise care while replacing front panel windows to prevent scratches.

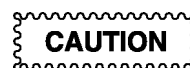

Care must be taken when using a solution of water and liquid dishwash soap to clean panels, as switch shafts/contact on some panels are susceptible to corrosion damage by water contact.

- d. Only use a solution of water and liquid dishwash soap on front panels. Solvents may damage front panel material.

8.6 CLEANING.

Table 8-1. Equipment Used for Front Panel Repair

Part Number	Nomenclature/Manufacture
Any Source	5VAC Adjustable Power Supply
31-33-04	High Intensity Lamp Bausch/Lomb or equivalent
MO-120	Motorized Flexible Shaft/Accessories

TO 00-25-234

Table 8-1. Equipment Used for Front Panel Repair - Continued

Part Number	Nomenclature/Manufacture
58	Vented Air Drying Oven
Local Mfrs	Panel Holding Fixture
Local Mfrs	Front Panel Mold
Any Source	Pneumatic Power Sander
Local Mfrs	Dental Tools/Accessories
EN-11000	Motorized Engraving Machine
9HT2256L	Motorized Sander/Grinder
Any Source	Sanding Block
9HT2433A	Bandsaw
SX213	Pace Desolder System or equivalent
Binks 18	Spray Gun-Binks or equivalent
Local Mfrs	Wiring Diagram Stencil
30HT15506	Air Brush Paint Unit Craftsman or equivalent
Local Mfrs	Silkscreen/Fixture
779CABA	Stereozoom microscope, Bausch and Lomb or equivalent
----	Pantograph



- Some panels are readily damaged by solvents, including alcohol.
 - Care must be taken when using a solution of water and liquid dishwash soap to clean panels, as switch shafts/contact on some panels are susceptible to corrosion damage by water contact.
- a. Use a soft bristle brush, dipped in a solution of water and liquid dishwash soap, to remove any dust or dirt from panel.
 - b. Use air pressure not to exceed 30 psi to remove any foreign particles from connectors and crevices.

- c. Remove grease or oil with a clean, lint free cloth moistened with a solution of water and liquid dishwash soap.

8.7 INSPECTION.

Visually inspect entire panel for obvious damage such as broken corners or cracks.

- a. Using a high intensity lamp, scan the back side of the panel while observing the front for light leaking through any hidden cracks.
- b. If any cracks or breaks are found, refer to Paragraph 8.10 for repair.

Table 8-2. Consumable Materials Required for Front Panel Repair

Reference Specifications and Standards	
Ink Thinner	A-A-2904
Ink Retarder	A-A-857
Clear Flat Epoxy Based Ink Kit	MIL-C-83286
Flat Black Epoxy Based Ink Kit	MIL-C-22750
Flat White Epoxy Based Ink Kit	MIL-C-83286
Acrylic Adhesive	MIL-A-8576B, Type II or equivalent
Mold Release	122NC02 (18598)
White Paint (Lacquer)	MIL-L-81352
Pliobond Cement	Or equivalent
	Any Source
Adhesive	MIL-A-46050
Sandpaper (Wet/Dry)	Any Source

NOTE

The following paragraph applies only to illuminated front panels with embedded wiring and lighting. Front panel illumination circuitry will vary from panel to panel, therefore, reference should be made to the appropriate illumination circuitry for initial testing. For cosmetic repair only, refer to Paragraph 8.11 through Paragraph 8.20.

8.8 INITIAL TESTING (FRONT PANEL REMOVED FROM LRU).

Use appropriate tech data for pin reference of front panel illumination checkout and power supply requirements.

- a. Apply power across appropriate pins to illuminate INDICATOR lights on front panel. Note any defective lights.
- b. Apply power across appropriate pins to illuminate entire front panel lighting system. Note defective lights or defective light areas.
- c. Refer to Paragraph 8.13 for replacement of faulty bulbs noted in Step a or Step b above.

NOTE

The following step applies only to those front panels with discrete annunciator caps.

- d. If any of the discrete annunciator caps are defective, refer to Paragraph 8.13 for replacement.

8.9 TROUBLESHOOTING.

Troubleshooting is an organized, systematic approach to locating and identifying parts or causes for a malfunction.

- a. Using a blackout box or a darkened room, apply required power to the appropriate lighting circuit on front panel.
- b. Determine if the panel has any defective lighted areas, broken buss wires or faulty light bulbs by visually inspecting the panel for any abnormal lighting indication. In most cases, if the unlighted areas are small and isolated, the bulb is bad.
- c. Isolate the problem area by referring to the wiring and bulb location diagram on the back of the panel. See Figure 8-1.
- d. If necessary, scrap a small amount of black paint, on the back of the panel, away from the questionable unlighted area to determine if the bulb is lighted.

- e. After determining the cause of the malfunction, refer to Paragraph 8.13 for faulty bulb replacement or Paragraph 8.12 for broken buss wire repair.

8.10 REPAIR OF CRACKED OR BROKEN PANELS.

Chips and loose material may be removed using a mechanical flex drive unit and grinding accessories.

WARNING

Plastic particles may cause skin or lung irritation. Safety goggles and half face respirator with dust filters must be worn during all grinding operations. Make sure this operation has been reviewed by local bioenvironmental engineers or Base medical services.

- a. Bevel and undercut the edges of the damaged area (make a "V") on front and back of panel to provide strength at bond area. Refer to Figure 8-2.
- b. Clean away plastic chips and dust using air pressure not to exceed 30 psi.
- c. Clean prepared repair area with a lint free cloth and a solution of water and liquid dishwash soap.
- d. Refer to Paragraph 8.15 for filling of excavation and Paragraph 8.17 for sanding.

8.11 REPAIR OF BROKEN CORNERS.

Chips and loose material may be removed using a mechanical flex drive unit and grinding accessories.

WARNING

Plastic particles may cause skin or lung irritation. Safety goggles and dust protection mask must be worn during all grinding operations.

- a. Bevel and undercut the edges of the damaged area on front and back of panel to provide strength at bond area.
- b. Clean prepared repair area with a lint free cloth and a solution of water and liquid dishwash soap.
- c. Select the appropriate front panel corner piece to fit panel being repaired. See Figure 8-2.
- d. Apply mold release to mold. Do not apply mold release to panel repair area.

TO 00-25-234

CAUTION

Care must be taken not to over torque mounting screws when installing front panel, as damage to panel may result.

- e. Place front panel into panel mold using associated hardware.
- f. Refer to procedures outlined in Paragraph 8.15 for filling excavation. After filling excavation, proceed with Step g. below if necessary.

WARNING

Plastic particles may cause skin or lung irritation. Safety goggles and dust protection mask must be worn during all grinding operations.

- g. Trim panel edges and corners to desired shape using a bandsaw or motorized sander.
- h. Using a pantograph machine, mill the panel repair area for necessary windows, light sockets and desired shape.
- i. Refer to Paragraph 8.20 for front panel silk-screening procedures.

8.12 REPAIR OF BROKEN BUSS WIRE.

To determine and isolate a broken buss wire, refer to Paragraph 8.24 troubleshooting.

WARNING

Plastic particles may cause skin or lung irritation. Safety goggles and half face respirator with dust filters must be worn during all grinding operations. Make sure this operation has been reviewed by local bioenvironmental engineers or Base medical services.

- a. Remove all paint around the defective buss wire area, using a mechanical drive unit with grinding accessories.

NOTE

Use the wiring location diagram on rear of panel for location of encapsulated buss wire. See Figure 8-4.

- b. To remove plastic around defective buss wire area, use a rotary brush or a small bur and mechanical drive unit.
- c. Excavate along the buss wire channel to allow for repair access. Only excavate enough plastic to make the needed repair.

NOTE

Buss wire repair is made with a piece of wire the same diameter or slightly larger than the original wire.

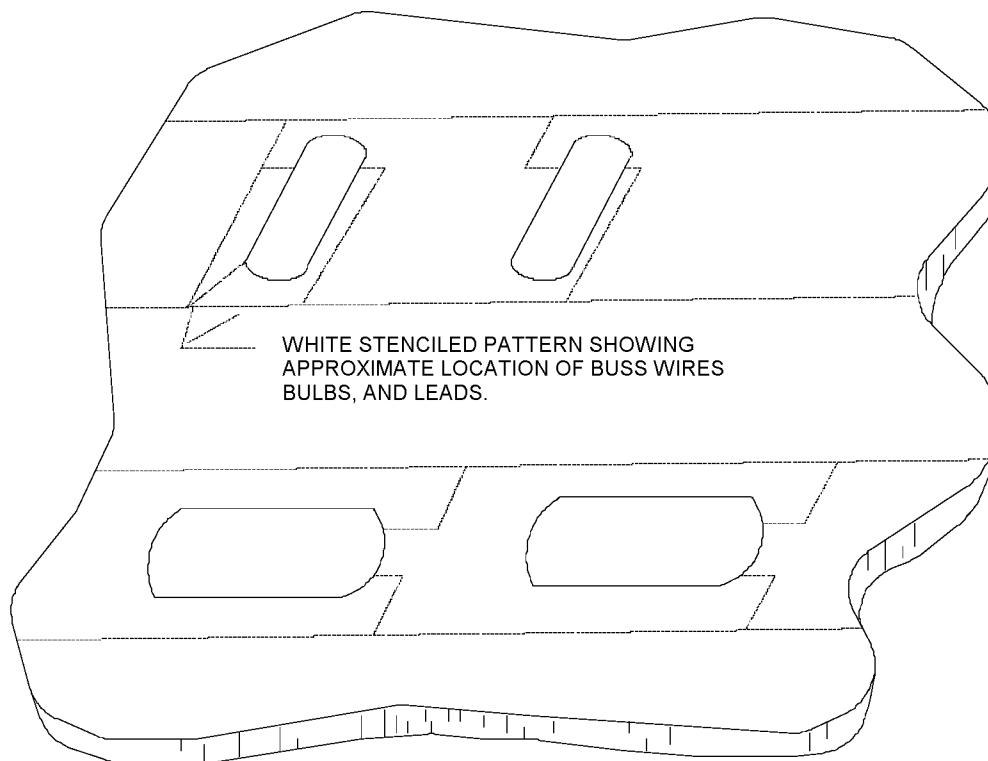

TO-00-25-234-096

Figure 8-1. Typical Stencil/Diagram

TO 00-25-234

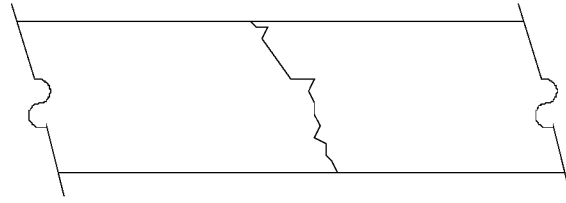

A. TYPICAL CRACK

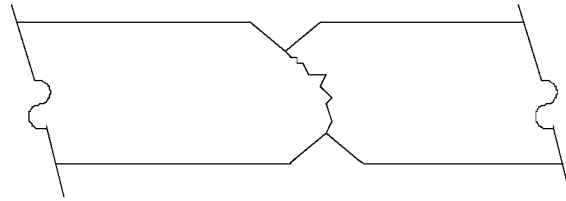

B. "V" ED CRACK

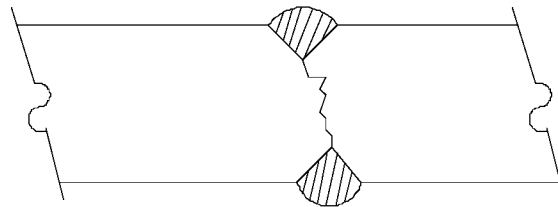

C. SLIGHT OVERFILL OF "V"

TO-00-25-234-097

Figure 8-2. Cracked Panel Repair

- d. After removing the defective length of buss wire, insert a new length of wire and make a clinch splice connection per Figure 8-3.

WARNING

Isopropyl Alcohol is flammable and toxic to skin, eyes and respiratory tract. Skin and eye protection is required. Avoid repeated or pro-longed contact. Use only in well ventilated areas. Do not use synthetic wiping cloths with flammable TT-I-735 isopropyl alcohol. Keep away from open flames or other sources of ignition.

CAUTION

Care should be taken while cleaning leads to make sure alcohol does not come in contact with the panel's plastic surface, as alcohol may damage some plastic panel surfaces.

NOTE

Perform all soldering in accordance with Chapter 4.

- e. Crimp leads together to ensure a firm connection and solder.
- f. Thoroughly clean the leads and repair area with isopropyl alcohol. Inspect the solder connection for uniformity and maximum contact.
- g. Place the repaired buss wire into excavated channel making sure the wire is below the surface of the panel.
- h. Refer to Paragraph 8.15 for filling excavation and Paragraph 8.17 for sanding.

8.13 REPLACEMENT OF FAULTY BULBS.

To determine and isolate faulty bulbs, refer to Paragraph 8.24 troubleshooting.

WARNING

Plastic particles may cause skin or lung irritation. Safety goggles and dust protection mask must be worn during all grinding operations.

- a. Remove all paint around the defective bulb area using a mechanical drive unit with grinding accessories.

NOTE

Use the bulb location diagram on rear of panel for location of encapsulated bulbs. See Figure 8-4.

- b. To remove plastic around defective bulb area, use a rotary brush or a small bur and mechanical drive unit.

NOTE

Lamp removal will be performed under a microscope. Do not excavate more plastic than necessary to accomplish the repair. Use of a drill press holder may be required. Excavation of the lamp area may be performed by using a mechanical drive unit with mills and cutters or a hot air jet method with extractor tip.

- c. Carefully grind the plastic away from the top and sides of the defective lamp. See Figure 8-4.
- d. Using a desoldering tool, select a tip small enough to allow only a pinpoint stream of hot air to melt the plastic under the bulb.
- e. Adjust the desoldering tip temperature to the highest point. Reverse the air flow and adjust the pressure to a minimum. Holding the tip 1/2 inch from the lamp, blow hot air on the defective part.

NOTE

A back and forth motion with the tip will help prevent damage to the colored insert.

- f. After the plastic under the bulb softens, the lamp can be removed using an orangewood stick, nylon probe or a dental pick.
- g. Carefully excavate around the leads to the soldered buss line connection or expose the lead so it can be clinch spliced per Figure 8-3.

CAUTION

When soldering leads in the excavated area, use caution not to melt any plastic with the soldering iron in the surrounding area. Any softened or melted plastic must be removed.

NOTE

Perform all soldering in accordance with Chapter 4.

- h. Solder the new lamps in accordance to Figure 8-4. Clinched splices will have 270 degrees to 360 degrees wrap.

NOTE

Any damaged colored insert or heat sinks/reflectors must be replaced. Refer to Paragraph 8.16.

- i. Refer to Paragraph 8.15 for filling excavation and Paragraph 8.17 for sanding.

TO 00-25-234

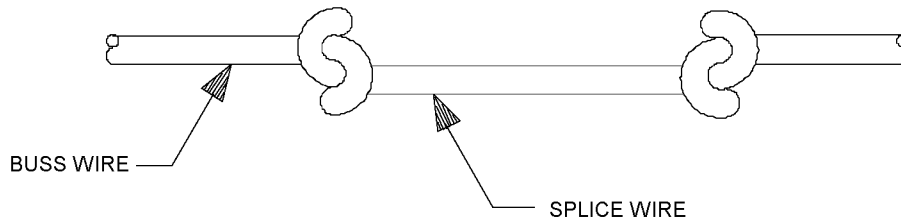
8.14 REMOVAL/REPLACEMENT OF FILTERS/ REFLECTORS.

TO-00-25-234-098

Figure 8-3. Clinched Splice

- a. Remove the cylindrical colored filter by using an end mill the same diameter as the filter being removed. Center mill over filter and mill to a depth equal to length of new cylindrical filter. Remove metal reflector.

NOTE

Replacement of the filter and metal reflector is required only if damaged during lamp removal.

- b. Remove bathtub type colored filter by using an end mill the same diameter as the semicircle at either end of filter. Center mill over either end of filter and mill to a depth equal to height of replacement filter. Move mill along major diameter of filter to complete removal. An alternate method is to make two cylindrical holes each concentric with the radius at the ends of the bathtub filter. Remove the metal reflector.

- c. Replace the filter/reflector by selecting the correct color and shape filter and bond metal reflector to filter using clear cast epoxy and hardener. Ensure that the reflector fits against the filter. Allow epoxy to harden. Deposit one bead of epoxy into center of lamp cavity. Insert filter/reflector assembly into cavity with a force until epoxy hardens.

8.15 FILLING EXCAVATION.

The following procedure is performed after any excavation has been completed on front panels.

- a. Using a solution of water and liquid dishwash soap and a soft brush, thoroughly clean excavated areas and let solvent air dry.

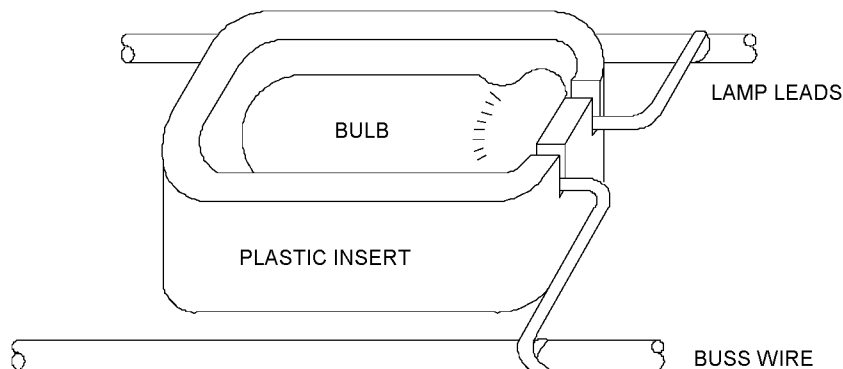

TO-00-25-234-099

Figure 8-4. Typical Bulb Insert

WARNING

MIL-A-8576B, Type II is toxic to eyes, skin, and respiratory tract. Avoid skin and eye contact. Use only in a well ventilated area.

- b. Mix acrylic adhesive MIL-A-8576B, Type II or equivalent in accordance with manufacturer's instructions.
- c. Pour adhesive into the excavated area(s) and fill slightly above the surface to allow for shrinkage during curing period. See Figure 8-2.
- d. Place the panel in a clean, well vented area and allow adhesive to cure for four hours. The panel may then be handled. An additional curing time of 24 hours is necessary before machining or sanding panel.

WARNING

Handling hot items presents a serious burn potential. Heat resistant gloves should be worn when removing panel from oven.

NOTE

The additional curing time of 24 hours may be accelerated by placing the panel in an oven with the temperature not to exceed 70 °C (158 °F) for four hours.

- e. Remove panel from oven and let cool at room temperature.

8.16 REMOVAL, REPLACEMENT OF FILTER BRACKET, PILE FASTENERS AND ANNUNCIATORS.

- a. All filter brackets, pile fasteners and annunciator caps must be removed from panel prior to silkscreen preparation.
 - (1) Place the panel on a flat surface. Care should be taken not to damage the connector(s) on the rear of panel when working on the front of the panel.
 - (2) Using the hot air jet from a Pace Desoldering Unit, heat the filter bracket, pile fastener or annunciator cap around the edges until the adhesive is soft enough to remove the component.
 - (3) Gently pry up on the edges with a dental pick until the component comes loose from the panel.

- b. All filter brackets, pile fasteners and annunciator caps must be reinstalled after panel has been silkscreened; however, bonding of the annunciator cap will be different.

- (1) Filter bracket and pile fastener.

WARNING

- Adhesive bonds to skin instantly. Avoid all contact. In case of contact, flush with water and obtain medical attention. Do not attempt to peel from skin.
- Isopropyl Alcohol is flammable and toxic to skin, eyes and respiratory tract. Skin and eye protection is required. Avoid repeated or prolonged contact. Use only in well ventilated areas. Do not use synthetic wiping cloths with flammable TT-I-735 isopropyl alcohol. Keep away from open flames or other sources of ignition.
 - (a) Mix epoxy adhesive in accordance to manufacturer's instructions.
 - (b) Use a wooden spatula to spread a thin, uniform layer of adhesive, 0.002 to 0.005 inch thick, on areas to be bonded.
 - (c) Carefully align component over bonding area and firmly press component into place.
 - (d) Carefully remove all excess adhesive around bonded part(s) with a wooded spatula and a lint free cloth moistened with isopropyl alcohol.

WARNING

Pliobond Cement is flammable and toxic to eyes, skin, and respiratory tract. Avoid skin and eye contact. Good general ventilation is normally adequate. Keep away from open flames or other sources of ignition.

- (2) Annunciator. Cement annunciator cap into place using a drop of pliobond cement around edges of cap.

TO 00-25-234**8.17 SANDING.**

All front panels must be sanded prior to silkscreening. Sanding rear of panel will be accomplished same as the front, but only as needed.



Extreme care should be taken not to over torque mounting screws on front panel as damage to the panel may result.

- a. Install front panel into holding fixture and secure using associated mounting hardware.

NOTE

Use sanding block or pneumatic sander when performing any sanding to ensure uniform contact with front panel surface.

WARNING

Plastic particles may cause skin or lung irritation. Safety goggles and a half face respirator with dust filters must be worn during all sanding operations. Make sure this operation has been reviewed by local bioenvironmental engineers or Base medical services.

- b. Wet surface of front panel. Use a sanding block or pneumatic sander and 240 grit wet/dry sandpaper. Sand panel surface until all large grooves and paint are removed. Surface will have a semi-smooth finish.
- c. Repeat wet sanding process using 360 grit wet/dry sandpaper and then 400 grit wet/dry sandpaper until panel surface has completely smooth finish. Remove panel from holding fixture.
- d. Clean prepared surfaces with a lint free cloth moistened with isopropyl alcohol.

8.18 MIXING AND PAINTING PRIMER INK.

Use applicable engineering drawings in accordance with DOD-D-1000 to determine which kind and color of ink is required for the primer coat. Both sides of the panel will be painted with the primer ink; however, the front may be silkscreened instead of spray painted.

- a. Mix ink in accordance with manufacturer's instructions. Thin ink using paint thinner as needed for spray gun applications.
- b. Mask any connector plugs, annunciators, clean cylinders or clear light ports on the front or rear of panel.

WARNING

Paint is flammable and toxic to eyes, skin, and respiratory tract. To prevent possible personnel injury, only paint in well ventilated paint booth. Prolonged inhalation of vapors may be hazardous.

- c. Paint both sides of panel using spray gun and primer ink. Repeat applications until both sides are uniformly coated.
- d. Cure ink in accordance with manufacturer's instructions.

8.19 MIXING AND PAINTING BACKGROUND INK.

Use applicable engineering drawings in accordance with DOD-D-1000 to determine which kind and color of ink is required for the background coat. Only the back of the panel will be painted; the front of the panel will be silkscreened.

- a. Mix ink in accordance with manufacturer's instructions. Thin ink using paint thinner as needed for spray gun applications.
- b. Mask the front of the panel where silk-screening is to be accomplished.
- c. Paint rear side of panel using background ink and a spray gun. Cover all areas not masked, including inside of cutouts. Coat as necessary to ensure no primer ink is visible.
- d. Carefully remove masking from panel and cure ink following manufacturer's instructions.

8.20 SILKSCREENING.

The following procedure should be performed by personnel trained in the process of silkscreening. Special care should be taken to produce clean, clear lettering on the panel. Perform Paragraph 8.17 through Paragraph 8.19 prior to silkscreening.



When installing panel into silkscreen fixture, do not over torque screws as damage may result to paint, contact pins or panel.

- a. Install front panel in lower silkscreen fixture with mounting hardware and ensure panel is flat. The panel fastening screws must be below the panel face and the panel will protrude slightly above the lower silkscreen fixture.
- b. Using poster paper for shims, shim outer screen frame edge inward until the shims butt against panel edges on both sides and bottom. This will support the screen while the ink is drawn over the surface.
- c. Carefully align silkscreen registration markings with panel markings.

NOTE

Silkscreen “off height” in the following step will change slightly depending on the size and tightness of the screen. “Off height” is the space between the screen and the panel.

- d. Lower upper screen frame onto the stops. Turn thumb screw adjustments at the top of screen frame to desired silkscreen “off height” of approximately 3/8 inch.
- e. Apply epoxy silkscreen ink to the screen along the edge of the panel. Using one continuous motion, pull squeegee bar across silkscreen and panel until length of panel has been covered.
- f. Lift screen frame and inspect panel to ensure panel is covered correctly and ink has a uniform consistency.
- g. If screening does not produce clean, clear lettering, clean ink from panel using a lint free cloth and paint thinner. Wipe all ink away until only the primer undercoat is showing and repeat silkscreening process, Step e and Step f above.

NOTE

Do not allow ink to dry on screen. Remove with lint free cloth and paint thinner.

- h. Remove panel from silkscreen fixture and allow ink to dry at room temperature for 20 minutes.

- i. Place panel in oven and allow to cure for one hour at 150 °F±20 °F.

WARNING

To prevent possible personnel injury, heat resistant gloves should be worn when handling hot components.

- j. Remove panel from oven and allow to cool until panel can be handled.
- k. Use a small paint brush and silkscreen ink to touch up panel edges where light may show through.

8.21 CLEAR EPOXY INK APPLICATION.

Use applicable engineering drawings in accordance with DOD-D-1000 to determine which kind of ink is required.

- a. Wipe dust from panel surface using lint free cloth.
- b. Mix clear ink in accordance with manufacturer’s instructions.
- c. Apply one light coat of clear ink to panel.
- d. Cure ink in accordance with manufacturer’s instructions.

8.22 WIRING BULB LOCATION STENCILING.

If wiring location stencil touch-up is all that is necessary, it can be accomplished by using a small paint brush and flat white lacquer paint. If wiring location stencil replacement is necessary, complete the following steps.

- a. Install wiring location stencil on rear of panel. Align stencil with outer edges of panel.
- b. Tape outer edge of stencil to the panel. Do not cover stencil cut-outs with tape.
- c. Using flat white lacquer paint spray can or air brush, lightly cover entire stencil with paint. Allow the paint to air dry in accordance with manufacturer’s instructions.
- d. Remove masking tape and stencil from panel.

TO 00-25-234**8.23 CONNECTOR PLUG REMOVAL REPLACEMENT.**

Although connector plug types vary on front panels, the following replacement procedure can be followed to replace most plugs. Plug excavation should be accomplished using a stereozoom microscope.

a. Plug Removal.

- (1) Using a standard ruler, find the plug location measurements by taking a vertical and a horizontal measurement from the plug center pin to the edges of the panel. Record the measurements.

WARNING

Plastic particles may cause skin or lung irritation. Safety goggles and half face respirator with dust filters must be worn during all grinding operations. Make sure this operation has been reviewed by local bioenvironmental engineers or Base medical services.

NOTE

These measurements will be used for further reference in a following step. The following steps will be performed using a stereozoom microscope.

- (2) Using a flexible drive unit and a #8 dental bur, excavate around the plug approximately 3/8 inch from center pin. Cut plastic away until plug tabs or pins and wires are visible.
- (3) Continue to excavate along the plug wires until enough wire is visible for plug removal.
- (4) Using a desoldering tool and a dental pick, remove the remaining plastic around the plug tabs or pins and wires.

NOTE

Perform all soldering/desoldering in accordance with Chapter 3 and Chapter 4.

- (5) Desolder wires from plug.
- (6) Using heat from a desoldering system, and tweezers, pull wires away and back from plug.
- (7) Using a #6 dental bur, clean excess plastic from wire channels and under plug.
- (8) Heat the plug using a desoldering system and remove the plug with a dental chisel.
- (9) Using a #6 dental bur and air pressure, not to exceed 15 psi, clean out plug hole.

b. Plug Replacement.

- (1) Shape plug hole as necessary for new plug to fit measurements recorded in Step a(1) See Figure 8-6 for typical plug excavation.
- (2) Apply a small amount of adhesive in plug hole and position plug for correct depth and tab or pin alignment. Allow adhesive to air dry for 15 minutes.

NOTE

Perform all soldering in accordance with Chapter 3 and Chapter 4.

- (3) Trim plug tabs or pins and solder on wires.

NOTE

If wires are short, refer to Chapter 4 (of source TO) and splice on new wires.

WARNING

Isopropyl Alcohol is flammable and toxic to skin, eyes and respiratory tract. Skin and eye protection is required. Avoid repeated or pro-longed contact. Use only in well ventilated areas. Do not use synthetic wiping cloths with flammable TT-I-735 isopropyl alcohol. Keep away from open flames or other sources of ignition.

- (4) Clean soldered areas with a soft brush and isopropyl alcohol.

8.24 FINAL TESTING.

Visually inspect the quality of the front panel finish and the clarity of indicator numbers and letters.

NOTE

- The following step should be performed using a blackout box or in a darkened room. Front panel illumination circuitry will vary from panel to panel. Reference should be made to the appropriate circuitry for testing.
 - If any extreme variation of local brightness is observed, the quantity of light intensity can be measured by referring to MIL-P-7788 paragraph 4.4.12.2, paragraph 4.2.2.1.3, paragraph 4.3.2 and paragraph 6.5.1.1.
- a. Apply power across the appropriate panel lighting pins.
 - b. Visually inspect illuminated panel for any extreme variation of local brightness across entire panel.

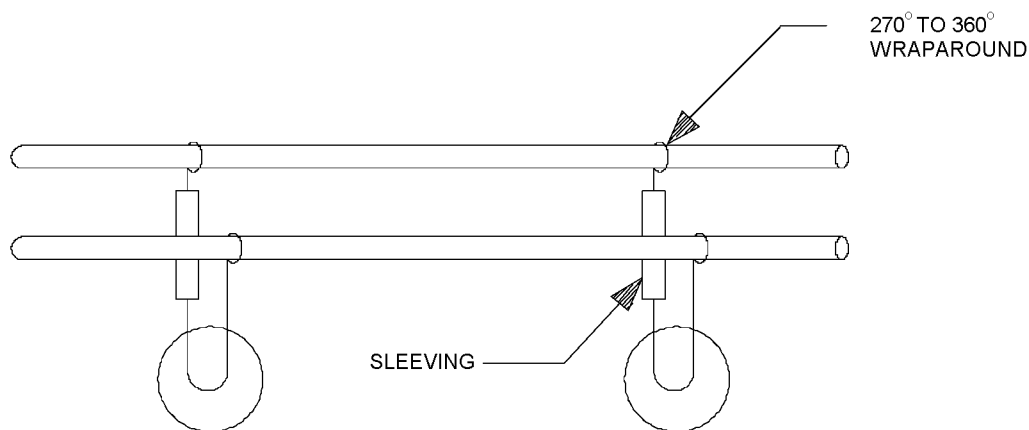

TO-00-25-234-100

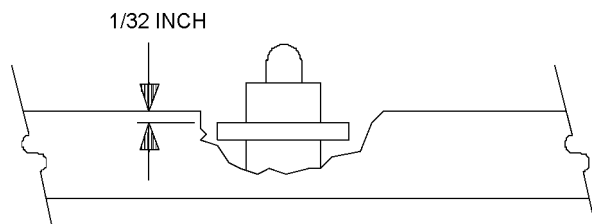
Figure 8-5. Buss Wire Connection

TO-00-25-234-101

Figure 8-6. Typical Excavated Plug

TO 00-25-234

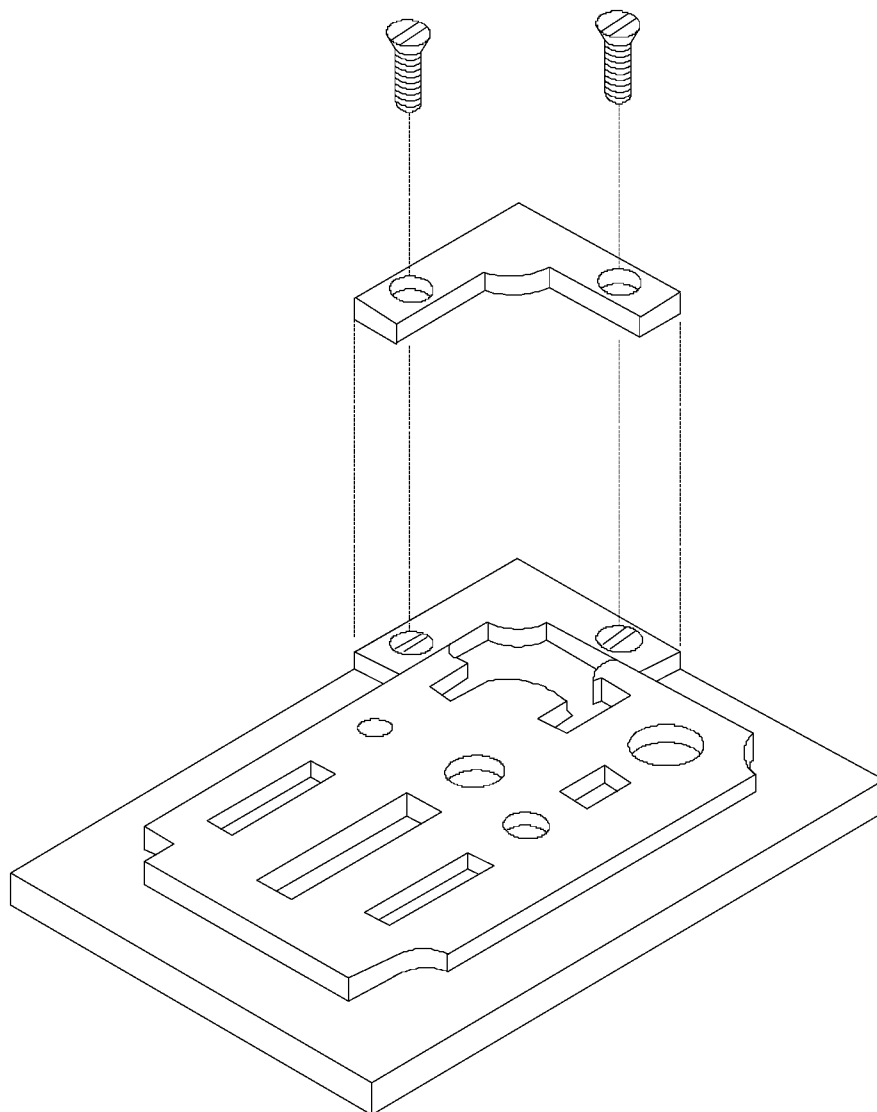

TO-00-25-234-102

Figure 8-7. Front Panel Mold

CHAPTER 9

FLEXIBLE PRINTED CIRCUIT REPAIR PROCEDURES

9.1 GENERAL.

Within the semiconductor industry, manufacturers are continuously trying to increase density, reliability and miniaturization of printed circuits. As a result, the Flexible Printed Wiring concept has had a tremendous impact on military electronics. The repair procedures for Flexible Printed Cir-

cuit Boards have been removed from this TO and personnel shall refer to TO 00-25-259, Standard Maintenance Practices Miniature/Microminature Electronic Assembly Repair. When other technical documents refer personnel to TO 00-25-259 for Flexible Printed Circuit Board Repair, TO 00-25-259 maintains precedence and personnel shall refer to TO 00-25-259 for proper repair processes and procedures.

CHAPTER 10

SUSPECTED COUNTERFEIT PARTS OR MATERIAL

10.1 GENERAL.

Counterfeit Material. Management of counterfeit material is a subset of discrepant material. Counterfeit and/or suspect counterfeit material requires additional actions be taken.

10.1.1 Counterfeit Materiel. Materiel whose identity has been deliberately altered, misrepresented, or falsified including but not limited to, any type. of material that consists of: a) a substitute or unauthorized copy of a valid product from an original manufacturer; b) a product in which the materials used or the performance product has been changed without notice by a person other than the original manufacture of the product.

10.1.2 Suspect Counterfeit Materiel. An item it which visual inspection, testing or other means indicate that it may not conform to established Government or industry-accepted specifications or national consensus standard, or one whose documentation, appearance; performance material or other characteristics may have been misrepresented by the supplier or manufacturer.

References;

Refer to AFMAN 23-110V1, PT1, Ch16, Management of Suspect Counterfeit and Counterfeit Materials.

Refer to TO 00-35D-54, USAF Deficiency Reporting, Investigation and Resolution.

Refer to AFI 21-101, Aircraft and Equipment Maintenance Management.

Refer to SAE (Society of Automotive Engineers) AS5553 Counterfeit Electronic Parts; Avoidance Detection, Mitigation and Disposition.

GLOSSARY

A

ABRASION POINT — A protrusion of a wire or lead, over the base or pad of a connection. A major fault.

ABRASIVE — A substance used for cleaning or grinding.

ACCEPTABLE — A satisfactorily soldered connection.

ADHESION — A force that holds two objects together.

ALLOY — A mixture of two or more metals melting together.

AWG — American Wire Gauge

B

BACK OF TERMINAL — That part of a terminal that is opposite to where the wire enters.

BASE MATERIAL — The insulating material upon which the conductive pattern may be formed. The base material may be rigid or flexible.

BASE OF TERMINAL — The flat portion of a terminal that the wire rests on.

BENT LEAD — A lead which is bent to the conductor pattern with an angle to the pattern between 30 degrees and 60 degrees.

BIFURCATED (SPLIT TERMINAL) — A terminal containing a slot or split in which wires or leads are placed before soldering.

BIRDCAGE — A defect in stranded wire where the strands in the stripped portion between the covering of an insulated wire and a soldered connection (or an endtinned lead) have separated from the normal lay of the strands.

BOND STRENGTH — The degree to which two materials are held together.

BUS WIRE — A solid conductor used for interconnections.

BLOW HOLE — A void caused by outgassing.

C

CAPILLARY ACTION — The combination force, adhesion and cohesion, which cause liquids, including molten metals, to flow between closely spaced solid surfaces, even against gravity; causes wicking. (Ex. lamp wick, ink blotter, sugar cube).

CAPPING HOLE — Providing a thin cover of solder over the hole in a bifurcated terminal, a plated through hole, etc.

CERTIFICATION — The act of verifying that required training has been completed, and/or specified proficiency has been demonstrated.

CHEMICAL STRIPPING — The process of removing insulation from wire or protective coating from printed boards using chemical compounds.

CLEAVAGE STRENGTH — The force preventing a splitting or dividing of two objects.

CLINCH — To fasten by bending the projecting end.

CLINCHED LEAD — A lead which is bent to the conductor pattern having a maximum angle to the pattern of 30 degrees.

COHESION — Force of attraction between like molecules.

COLD JOINT — Contrary to the many publications and specifications dealing with solder connections, a cold joint does not necessarily have a dull, chalky, or granular appearance. This description more nearly describes a fractured or overheated joint. A cold joint results from insufficient temperature of the soldering iron tip or failure of the assembler to allow the terminal or connection to reach the correct temperature before applying solder. The size or mass of the terminal or connection should be considered in choosing the correct wattage soldering iron. (A cold joint will appear full,

TO 00-25-234

round, piled up, and will usually be shiny.) The solder will not have the characteristic feathered out low fillet of a good joint.

COMPONENT — A part or combination of parts mounted together to perform a design function(s). A separable part of a printed board assembly which performs a circuit function (e.g resistor, capacitor, transistor, etc.).

COMPONENT LEAD — The wire, or ribbon, which extends from and serves as a connection to a component.

COMPONENT SIDE — The side of a printed circuit board that contains the components.

CONCAVE — Hollow and curved as the inside of a sphere.

CONDUCTIVE PATTERN (FOIL) — The configuration or design of the conductive material on the base material. (Includes conductors, lands, and through connections when these connections are an integral part of the manufacturing process).

CONDUCTOR SIDE — The side of a printed circuit board that contains the conductive foil pattern.

CONFORMAL COATING — Layer of a protective substance that conforms to or follows the outline of the components.

CONNECTION — The area where two or more objects are joined.

CONNECTOR PIN — A terminal used in a cable assembly.

CONTAMINATE — To make unclean or dirty.

CONTOUR SOLDERING — Applying solder so the outline of the conductor is visible after soldering.

CONVEX — Curving outward like the outside of a sphere.

CORDWOOD CONSTRUCTION — Circuitry in which parts are mounted between, and perpendicular to, two printed wiring or conductive networks.

CORROSION — The deterioration of a metal by chemical reaction.

COUNTERFEIT PARTS OR MATERIAL — Material whose identity has been deliberately altered, misrepresented, or falsified including but not limited to, any type of material that consists of: a) a substitute or unauthorized copy of a valid product from an original manufacturer; b) a product in which the materials used or the performance product has been changed without notice by a person other than the original manufacture of the product.

D

DEGRADATION — A gradual deterioration in performance. The synonym 'drift' is often used in electronic equipment.

DELAMINATION — A separating of the conductive foil from the substrate.

DEVIATION — A specific authorization, granted before the fact, to depart from a particular requirement of specifications or related documents.

DEWETTING — A condition which results when molten solder has coated a surface and then receded leaving irregularly shaped mounds of solder separated by areas covered with a thin solder film; base metal is not exposed.

DISTURBED SOLDER CONNECTION — Unsatisfactory connection resulting from relative motion between the wire and the terminal during solidification of the solder.

DOUBLE SIDED BOARD — A printed circuit board that has conductive runs on both sides.

DOUBLE TINNED — The tinning process repeated. This is one technique to remove gold plating from leads of components.

DRESS — Prepare or make ready for use.

DROSS — The oxide scum present on the surface of molten solder baths or pots.

DUAL IN-LINE PACKAGE (DIP) — A component (usually an IC package) which terminates in two straight rows of pins or leads wires.

E

ELECTROSTATIC DISCHARGE (ESD) — A transfer of electrostatic charge between bodies at different electrostatic potentials caused by direct contact or induced by an electrostatic field.

ELEMENT (OF A MICROCIRCUIT OR INTEGRATED CIRCUIT) — A constituent of the microcircuit or integrated circuit that contributes directly to its operation. (A discrete part incorporated into a microcircuit becomes an element of the microcircuit.)

ENCAPSULATE — To cover or coat.

EPOXY RESINS — A resin that polymerizes spontaneously when its components are mixed, forming a strong, hard, resistant adhesive.

ESD PROTECTIVE MATERIAL — Material capable of one or more of the following: limiting the generation of static electricity, rapidly dissipating electrostatic charges over its surface, or providing shielding from ESD spark discharge or electrostatic fields.

ESD PROTECTIVE PACKAGING — Packaging with ESD protective materials to prevent ESD damage to ESDS items.

ESD SENSITIVE (ESDS) ITEMS — Electronic parts, assemblies and equipment that are sensitive to ESD voltages classified in Table IV, DOD-HDBK-263.

EUTECTIC SOLDER — Solder containing 63% tin and 37% lead; solder alloy with the lowest melting point (361 °F); solder alloy having a sharp melting point (no pasty range).

EXCESSIVE SOLDER CONNECTIONS — A connection unsatisfactory because the contour of the elements of the connection are completely obscured or one with solder overflowed beyond the confines of the connection area.

EYELET — A hollow tube inserted in a terminal or printed board to provide mechanical support for component leads or electrical connection.

EXCESSIVE WICKING — Any solder that flows under the insulation of stranded wire.

F

FILLET — The concave configuration of solder around a component lead and land. A blending or rounding of intersecting conductors or leads which eliminates sharp corners.

FILM INTEGRATED CIRCUIT — An integrated circuit consisting of elements which are films formed upon an insulating substrate.

FLAT PACK — A component with two straight rows of leads (normally on 0.050-inch centers) which are parallel to the component body.

FLUSH CUTTING TOOL — A device for making an even or unbroken line cut in a wire that is adjacent to a margin.

FLUSH MOUNT — Placing the component against the substrate.

FLUX — A liquid or solid reducing agent used to clean and prepare a surface to be soldered; any substance that promotes the fusion of two metals; any substance that aids the wetting action of solder which then improves solderability.

FLUX SOLDER CONNECTION — An unsatisfactory connection having entrapped flux, often causing high electrical resistance.

FRACTURED JOINT — This joint will resemble the dull, chalky or granular appearance of the over-heated joint but in addition will have a crack between the conductors. This condition results from moving the wire or conductor before the solder solidifies.

FROG EYE — Damage to substrate caused by excessive heat.

FRONT SIDE OF TERMINAL — That part of a terminal where the wire enters.

FUNGUS — Mildew, mould, etc.

FUNELLET — A metal tube with an angled flange used to line a hole.

FUSE — (1) To unite or blend together by melting. (2) A protective device that breaks a circuit when its current exceeds a predetermined value.

FUSION — Melting and combining two different metals

TO 00-25-234

G

GROUND — A mass such as earth, a ship or vehicle hull capable of supplying or accepting a large electrical charge. A point of common potential in an electric circuit used for common connections and reference voltages.

H

HARD GROUND — A connection to ground either directly or through a low impedance.

HARD SOLDERING — Joining two metals using alloys heated to a temperature over 800 °F.

HEAT BRIDGE — A pool of solder from the iron to the connection that allows a rapid transfer of heat.

HEAT SINK — A device, usually copper or aluminum, which clamps on a conductor to protect a component from excessive heat; also called a Thermal Shunt.

HIGH RELIABILITY — The state or quality of being very reliable or dependable.

HOOK TERMINAL — A terminal with a looped end.

HYBRID MICROCIRCUIT — A microcircuit consisting of elements which are a combination of the film circuit type and the semiconductor types or a combination of one or both of the types with discrete parts.

I

ICICLE — A cone-shaped peak or sharp point of solder, usually formed by the premature cooling and solidification of solder upon removal of the heat source.

IMPREGNATE — To fill or saturate.

IMPROPERLY BONDED JOINT — This joint will usually have a demarcation line between the conductors. This condition is often caused by oxidized, dirty, greasy, or otherwise contaminated conductors or component leads.

INSUFFICIENT SOLDER — Conductors with insufficient solder will have the appearance of being tinned and 'sweated' together with no apparent fillet. A joint should have sufficient solder to produce a low fillet between conductors.

INSULATION CLEARANCE — The distance between the terminal or terminal area and the wire insulation.

INSULATION GAP — The space between the tinned portion of a wire and the insulation; area free of solder.

INTEGRATED CIRCUIT — A physically small circuit consisting of many inseparable parts.

INTERFACIAL CONNECTION — A connection between the two sides of a double sided board.

INTERMETALLIC ACTION — The action where molten solder dissolves some of a base metal and forms a new metal containing both (ex. solder and copper).

J

JUMPER — An electrical connection between two points on a printed board added after the printed wiring is formed.

L

LAMINATE — To form into thin layers.

LAND — A portion of a conductive pattern usually, but not exclusively, used for the connection, or attachment, or both, of components.

LAP JOINT — A connection of two overlapping members.

LEAD — A length of insulated or uninsulated solid or stranded wire used for electrical interconnection of terminal joints.

LIP OF BASE — The extreme outer edge of the base of a terminal.

LIQUID STATE — The state of solder when it is completely melted.

M

MAGNIFICATION POWER — Rating of a lens' ability to increase the apparent size of an object.

MAJOR FAULT — A defect in the soldered connection that classifies it a reject.

MEASLING — Damage to a substrate caused by excessive heat.

MECHANICAL INSULATION STRIPPER — A device used to remove wire insulation by mechanical means.

MECHANICAL WRAP — The securing of a wire or the lead of a component around a terminal prior to the soldering operation.

MICROCIRCUIT — A small circuit having a high equivalent circuit element density, which is considered as a single part composed of interconnected elements on or within a single substrate to perform an electronic circuit function. (This excludes printed wiring boards, circuit card assemblies and modules composed exclusively of discrete electronic parts.)

MICROCIRCUIT MODULE — An assembly of microcircuits or an assembly of microcircuits and discrete parts designed to perform one or more electronic circuit functions, and constructed such that for the purposes of specification testing, commerce, and maintenance, it is considered indivisible.

MICRO-ELECTRONICS — That area of electronic technology associated with or applied to the realization of electronic systems from extremely small electronic parts or elements.

MONOLITHIC INTEGRATED CIRCUIT — An integrated circuit consisting of elements formed on or within a semiconductor substrate with at least one of the elements formed within the substrate.

MOUNTING HOLE — A hole used for the mechanical mounting of a printed board or for the mechanical attachment of components to the printed board.

MULTICHIP MICROCIRCUIT — A microcircuit consisting of elements formed on or within two or more semiconductor chips which are separately attached to a substrate.

N

NICK — A cut or notch in a wire or conductor.

NONWETTING — A condition whereby a surface has contacted molten solder, but the solder has not adhered to all the surface; base metal remains exposed.

NONWORKING SURFACE — That which is not part of the immediate area being worked upon.

O

OVERHEATED JOINT — The joint will appear dull, chalky and granular. This condition is caused by excessive iron temperature, allowing the iron tip to remain on the connection too long, or remelting the connection several times.

OXIDATION — When molecules of oxygen in the air combine with surface molecules of base metals.

OXIDES — The non-metallic film that forms on the surface of metals when oxygen molecules combine with molecules of the base metal.

P

PACKAGING DENSITY — The number of items per given area.

PAD — That portion of a conductive foil pattern that is used to solder component and wire leads.

PASTY RANGE — The condition of solder between the solid and liquid state; soft, mushy, pasty condition where liquid and solid crystals exist together.

PEEL STRENGTH — The ability to resist the removing of the surface layer by a peeling action.

PERFORATED OR PIERCED TERMINAL — A terminal containing a hole through which leads or wires are placed before soldering.

PHENOLIC — A coal tar derivative.

PIERCED TERMINAL — Having a hole or opening.

PITS — Holes or voids.

PITTED OR POROSITY JOINT — This joint will show evidence of pits, pin holes, or small craters in the solder. This joint can be caused by oxidization, the type of plating material used on conductors (gold plating will cause this condition) or other foreign matter not compatible with solder. The joint may also appear dull, depending on the amount of contamination present.

PLASTIC STATE — The condition of solder between the solid and liquid states.

TO 00-25-234

PLATED SOLDERING IRON TIP — A solid copper tip that has been plated or clad with iron, nickel, chromium, or similar metal that will extend the service life of the tip and increase heat transfer.

PLATE-THROUGH HOLE (PTH) — A hole in which electrical connection is made between internal or external conductive patterns, or both, by the deposition of metal on the wall of the hole.

PLATING — A thin coating of gold, tin, silver, etc.

PLIABLE — Flexible, easily bent or molded.

POLYSTYRENE — A clear, colorless, plastic material.

POLYTETRAFLUORETHYLENE — Wire insulation (Teflon).

POLYURETHANE — Various synthetic rubbery material used in cushions, insulations, and molded products.

POTTING COMPOUND, TWO-PART EPOXY — A substance, used to bond two or more objects, that sets to a ceramiclike hardness.

PRINTED CIRCUIT BOARD — The general term for completely processed printed circuit or printed wiring configurations. It includes single and double sided, multilayer, flexible, and flexible multilayer boards.

PRINTED CIRCUIT BOARD ASSEMBLY — A printed board with electrical or mechanical components, other printed boards, or a combination of these, attached to it with all manufacturing processes, soldering, coating, etc., completed.

PRINTED CIRCUIT PAD — A terminal area on a printed circuit used for making electrical connections to the conductive pattern.

PRINTED WIRING — A conductive pattern within or bonded to the surface of a base material intended for point to point connection of separate components and not containing printed components.

PROTECTED AREA — An area which is constructed and equipped with the necessary ESD protective materials and equipment to limit ESD voltage below the sensitivity level of the ESDS items handled therein.

PROTECTIVE HANDLING — Handling of ESDS items in a manner to prevent damage from ESD.

R

REDUCING AGENT — An agent that removes the oxygen molecules from a substance.

REJECTED — Classified as worthless or unusable, and unsatisfactory.

RELIABILITY — The probability that an item will perform its intended function for a specific interval under stated conditions.

REPAIR — Operations performed on a nonconforming article to place it in usable condition. Repair is distinguished from rework.

RESIDUE — That which is left after part is taken away.

RESIN — Any of various solid or semisolid organic substances exuded, from various plants and trees or comparable materials prepared synthetically.

RESIN CORE SOLDER — Wire solder that has its center filled with resin.

RESISTANCE SOLDERING — Method of soldering by passing a current, which heats the soldering area, by contact with two electrodes (not for sensitive semiconductor components).

REWORK — The reprocessing of articles or material that will make it conform to drawings, specification or contract.

RINGED — Deformation of a solid lead or conductor around the circumference usually resulting from worn or incorrect forming tools.

ROSIN — Hard, brittle resin, light yellow to almost black in color, remaining after oil of turpentine has been distilled from crude turpentine.

ROUTING — To expose by gouging or hollowing out.

S

SCORING — Marks, incisions, or notching on the individual conductor strands or a solid conductor that has reduced its diameter.

SCRATCH — A scratch is a relatively long and narrow furrow or groove, usually shallow, on the surface caused by marking or rasping the surface with something pointed or sharp.

SETUP — The condition of the terminal, wire, pad, etc., just prior to soldering.

SHEAR STRENGTH — The ability to resist the action or force causing two bonded parts or layers to slide upon each other.

SINGLE SIDED BOARD — A printed circuit board having a conductive pattern on only one side.

SOFT GROUND — A connection to ground through an impedance sufficiently high to limit current flow to safe levels for personnel (normally 5 milliamperes).

SOFT SOLDERING — Joining two metals using alloys heated to a temperature under 800 °F.

SOLDER — A fusible metal alloy, usually tin and lead, used to join two or more metals at a temperature below their melting points.

SOLDERABILITY — The ability of a metal surface to be wetted by molten solder; capable of being soldered.

SOLDER BRIDGE — Solder that spans a gap and connects another conductive pattern.

SOLDER CUP TERMINAL — A hollow, cylindrical terminal to accommodate one or more conductors.

SOLDER POT — A thermally controlled contained used to melt solder.

SOLDER SIDE — The side of a printed board which is opposite to the component side.

SOLDERING — A process of joining metallic surfaces with solder, without the melting of the base metals.

SOLDERING FLUX — A chemically active formulation capable of promoting the wetting of metals with solder.

SOLVENT — A substance that dissolves another substance.

SPACE MOUNT — Placing the component above the substrate.

SPILLAGE — Solder that is allowed to run, fall, or flow over a specified termination.

STATIC ELECTRICITY — An electrical charge at rest.

STEP SOLDERING — Technique for sequentially soldering connections on the part or terminal without impairing any of the prior connections. The first connection is made with a solder alloy having a higher melting temperature. The next is made with a solder alloy having a lower melting temperature. Additional solder connections are made with solder alloys having successively lower melting temperatures.

STRESS LINE — A deformed area in a solder connection.

STRESS LOOP — The forming of a slight curve in the leads of components to avoid stress between terminations.

STRESS RELIEF — Formation of leads that prevent strain on component.

STRIPPING — Removal of wire insulation by mechanical, chemical, or electrical means.

SUBSTRATE (OF A MICROCIRCUIT OR INTEGRATED CIRCUIT) — The supporting material upon or within which the elements of a microcircuit or integrated circuit are fabricated or attached.

SWAGE — A tool for bending or shaping metal.

TO 00-25-234

T

TENSILE STRENGTH — Resistance to lengthwise stress.

TERMINAL — A tie-point device used for making electrical connection. Basic styles of terminals are: bifurcated, hook, perforated or pierced, solder cup, turret and straight post.

TERMINAL BARREL — That portion of a terminal below the bottom base.

TERMINAL POST — On a bifurcated terminal, that portion above the base.

TERMINAL SHANK — That portion of a terminal below the bottom base.

THERMAL INSULATION STRIPPERS — A device used to remove insulation by thermal means.

THERMAL SHOCK — A sequence of reducing a soldering iron temperature rapidly to cause solidification of the contaminants for thorough cleaning.

THERMAL SHUNT — A device (also referred to as a heat sink) which has good heat dissipation characteristics used to conduct heat away from an object.

TINNING — Coating of a surface with a thin uniform layer of solder.

TO HEADER — A transistor or IC Package.

TORSIONAL STRENGTH — Resisting a twisting action caused by holding one end stationary and turning the other along the longitudinal axis.

TOXIC — A poison.

TRANSFER SOLDERING — A process wherein a measured amount of solder in the form of a ball, chip, or disc is picked up on a specially configured tip of a hand soldering iron and transferred to the prefluxed element of a connection to be soldered. The process was initially designed for soldering leads of planar mounted devices and miniature through-board connections and is equally suitable for other connections as well.

TURRET TERMINAL — A round post-type grooved stud around which wires or leads are snugly hooked before soldering. It may have either spacing shoulders or grooves for positioning the wires or leads.

U

UNPLATED SOLDERING IRON TIP — A soldering iron tip that has not been plated, i.e., bare copper.

V

VERTICAL MOUNT — Placing the component at a 90 degree angle to the substrate.

VISUAL EXAMINATION — The qualitative observation of physical characteristics, utilizing the unaided eye or with stipulated levels of magnification.

VOID — The absence of substance in a localized area.

VOLATILE — Changeable.

W

WAVE SOLDERING — A process wherein printed boards are brought in contact with the surface of continuously flowing and circulating solder.

WET SOLDERING IRON TIP — Heated soldering iron tip covered with a small quantity of molten solder to accelerate transfer of heat connection.

WETTING ACTION — The intermolecular attraction between the solder and a base metal which then forms a new alloy. The adhesion of a liquid to a solid metal surface.

WICKING — Capillary action which causes solder to flow in and around the strands of stranded wire.

WORK STATION — The solder work station is an identified area used for manual soldering. The area within 10 feet (3.05 M) of the actual soldering bench shall be considered a part of the work station.

WORKING SURFACE — That which is part of the immediate area being worked upon.

INDEX

Subject	Paragraph, Figure, Table Number	Subject	Paragraph, Figure, Table Number
B			
BOLTED ELECTRICAL CONNECTIONS	4.15	Capacitors	4.25.3
Inserting Aluminum Wire Into Aluminum Terminal		Electron Tubes	4.25.6
Lugs	F 4-48	Fuses	4.25.1
C			
CABLE BINDING AND LACING	4.11	Lamps	4.25.7
Braid Dead-Ending	F 4-35	Neon Lamps	4.25.8
Cable Branching	F 4-39	Power Cord Assembly	F 4-67
Cable Lace Termination	F 4-38	Resistors	4.25.2
Cable Lacing	4.11.1	Solid-State Devices	4.25.5
Cable Stitching	F 4-37	Switches	4.25.4
Cable Strap Installation	4.11.3	CONFORMAL COATING OF CERAMIC PRINTED	
Installing Self-Clinching Plastic Cable Straps . .	F 4-41	CIRCUITS (CPC'S)	6.9
MS90387 Adjustable Hand Tools for Installing Self-		Application of Coating	6.9.2
Clinching Plastic Tiedown Straps	F 4-42	Cleanup	6.9.4
Self-Clinching Plastic Cable Straps and Installation		Curing the Coating	6.9.3
Tools	T 4-5	Preparing Coating Material	6.9.1
Self-clinching Cable Straps	4.11.2	CONNECTOR PLUG REMOVAL	
Starting a Cable Lace	F 4-36	REPLACEMENT	8.23
Strap Configuration	F 4-40	CORROSION PREVENTIVE TREATMENTS	4.19
Typical Cascading Pigtails	F 4-34	Aluminum Alloy Parts	4.19.3
CLAMPS	4.7	Cadmium Plated Parts	4.19.5
Safety Wiring AN Connector to Structure	F 4-22	Connectors	4.19.2
Safety Wiring AN Connectors	F 4-21	Equipment Exteriors	4.19.1
Safety Wiring AN Split-Shell Assembly		Ferrous Alloys	4.19.4
Screws	F 4-23	Magnesium and Magnesium Alloys	4.19.6
Typical Clamps	F 4-24	Zinc and Zinc Plated Parts	4.19.7
CLEANING	2.8	CRIMPED ELECTRICAL CONNECTIONS	4.13
CLEANING	8.6	Crimp Inspection	4.13.4
Equipment Used for Front Panel Repair	T 8-1	Crimping Procedure	4.13.3
CLEANING PROCEDURES	4.18	Crimping Tools	4.13.2
Aerosol Cleaners	4.18.3	Hand Tools	4.13.2.1
Capacitor Leakage	4.18.7	Insulating Sleeves	F 4-47
Cleaning AN Connectors	4.18.5	Nylon Strapped Spot Tie	F 4-44
Cleaning Connector Prior to Potting	F 4-58	Power Tools	4.13.2.2
Cleaning Group A and Group B Components . .	4.18.6	Pre-Insulated Terminal Lug Cutaway	F 4-46
Cleaning Moderately Contaminated Devices . . .	T 4-7	Pre-insulated Terminal Lugs	4.13.1.1
Electric Hot-Air Gun	F 4-56	Solderless Terminal Lugs	F 4-45
Filling and Curing Potted Connector	F 4-59	Types of Solderless Lugs	4.13.1
Installation of O-Ring on Potted Connector . . .	F 4-60	Uninsulated Terminal Lugs	4.13.1.2
Moderate Contamination	4.18.1	E	
Other Cleaning Techniques	4.18.4	ECONOMICAL REPAIR	1.3
Precious Metal Contacts	4.18.8	EQUIPMENT CASES AND PANELS	4.3
Spare Wires for Potted Connector	F 4-57	Connectors	4.3.3
Types of Organic Solvents	T 4-8	Cracks and Holes	4.3.2
Typical Bolted Connections	F 4-55	Dents and Chips	4.3.1
Ultrasonic Cleaning	4.18.2	EQUIPMENT PERFORMANCE	4.4
CLEAR EPOXY INK APPLICATION	8.21	Deviations	4.4.1
COMPONENT SUBSTITUTION	4.25	Performance Test Conditions	4.4.1.1
Acceptable and Unacceptable Control Knob		Shock Testing	4.4.3
Damage	F 4-68	Vibration Testing	4.4.2
		Vibration and Shock Testing	4.4.1.2
		ESD SUSCEPTIBILITY	7.4

INDEX - CONTINUED

Subject	Paragraph, Figure, Table Number	Subject	Paragraph, Figure, Table Number
Circuit Boards, Modules and Assemblies	7.4.1.2	Portable ESD Control Workstation and Personnel Wrist Strap Grounding (Remote Indoor or Outdoor Operations)	7.5.7.3
Discrete Parts	7.4.1.1	Portable Static Control Workstation	F 7-5
ESD Sensitivity Defined	7.4.3	Portable Static Control Workstation	7.5.5.4
Susceptible Items	7.4.1	Principle Components	7.5.5
When Does ESD Susceptibility Stop	7.4.2	Relative Humidity	7.5.5.11
F			
FILLING EXCAVATION	8.15	Static Control Workstation (with cushioned work surface)	7.5.5.2
Typical Bulb Insert	F 8-4	Static Control Workstation (with rigid work surface)	7.5.5.3
FINAL TESTING	8.24	Static Control Workstation (work cushioned or rigid work surface on an existing work bench)	F 7-4
Buss Wire Connection	F 8-5	Static Control Workstations (Reference MIL-PRF-87893)	7.5.4.1
Front Panel Mold	F 8-7	Static Dissipative Flooring System	7.5.5.9
Typical Excavated Plug	F 8-6	Static Dissipative Gloves and Finger Cots	7.5.5.8
FRAMEWORK OF ESD CONTROL	7.5	Storage Cabinets and Static Dissipative Floor Grounding	7.5.7.2
Bench Top Ionizer Positioning	F 7-6	Typical Electrical AC Outlet	F 7-12
Bench Top Ionizers	7.5.5.7	Typical Service Entrance	F 7-13
Cleaning of ESDS Items	7.5.8	Use of Ground Fault Interrupters (GFI) for ESD Con- trol Purposes	7.5.7.4
Common Point Ground Systems (CPGS)	7.5.5.6	Work Area ESD Control Surveys	7.5.1
Computer Keyboard Ground Strips	7.5.5.12	FUNGUS PREVENTION	4.20
Conductive/Static Dissipative/Non-Charge Generating Materials	7.5.3	G	
ESD Attention Label/No Further Packaging Required	F 7-9	GENERAL	2.1
ESD Caution Label/Off Base Transport Items (MIL-STD-129)	F 7-11	GENERAL	3.1
ESD Control Label/ESDS Item Packages (MIL-STD-129)	F 7-10	GENERAL	4.1
ESD Control Product and Ground Integrity Test Equipment	7.5.5.13	GENERAL	5.1
ESD Control Products	7.5.4	GENERAL	6.1
ESD Control Strategies	7.5.2	GENERAL	7.1
ESD Control Workstation Grounding (Building Steel)	7.5.7.1	Applicability	7.1.3
ESD Control Workstation Grounding (Indoor Powered Operations)	7.5.6.3	Purpose	7.1.1
ESD Ground Measurement Reference Point	7.5.6.1	Scope	7.1.2
ESD Protective Equipment	T 7-3	GENERAL	8.1
Effects of Electrical Current on Humans (Reference MIL-STD-454)	T 7-4	GENERAL	9.1
Equipment Required For ESD Ground Integrity Checks	7.5.6.2	GENERAL	10.1
First Touch Installation Procedures	F 7-7	Counterfeit Materiel	10.1.1
Flow Chart for ESD Control Workstation Grounding	F 7-14	Suspect Counterfeit Materiel	10.1.2
Grounded Electrical Tools and Equipment	7.5.5.10	GENERAL PRECAUTIONS	8.5
Grounding	7.5.6	H	
Grounding Point	7.5.7	HANDLING AND STORAGE	2.9
MIL-STD-1285 Symbol	F 7-8	Chassis-Type Electronic Assembly, Protective Packaging	F 2-1
Marking	7.5.5.15	Circuit Board-Type Electronic Assembly, Protective Packaging	F 2-2
Other Grounding Requirements	7.5.7.6	Handling	2.9.3
Permanent Static Control Workstation	7.5.5.1	Plug-In Type Electronic Assembly, Protective Packaging	F 2-3
Permanent Static Control Workstation	F 7-3	Preparation for Shipment and Storage	2.9.2
Personnel Safety	7.5.7.5		
Personnel Wrist Strap	7.5.5.5		

INDEX - CONTINUED

Subject	Paragraph, Figure, Table Number	Subject	Paragraph, Figure, Table Number
Protective Measures for Electrical Connectors . . .	2.9.1	Anchor Nuts, Clinch Nut, and Plug Nut	F 4-15
HIGH TEMPERATURE PRESSURE-SENSITIVE		Application of Dowel Pin	F 4-3
TAPE	4.12	Application of Tapered Pins	F 4-4
Cable Lace, Spot Tie	F 4-43	Bucking Bar Recess	F 4-8
Spot Tying	4.12.1	Chassis Construction	4.5.1
Spot Tying with Nylon Straps	4.12.2	Clevis Pin	F 4-6
I		Countersunk and Skin-Dimpled Rivet Holes	F 4-7
IDENTIFICATION OF COATING	6.6	Eyelets	4.5.4
Acetone Test	6.6.6	Loose Fit	4.5.2.3
Burn Test	6.6.8	Pins	4.5.2
Color Comparison	6.6.11	Properly and Improperly Set Rivets	F 4-10
Color Test 1	6.6.9	Retaining Rings	4.5.6
Color Test 2	6.6.10	Rivet Head Criteria	F 4-9
Color Test and Identification of Conformal		Rivets	4.5.3
Coatings	T 6-3	Snug Fit	4.5.2.1
Conformal Coating Fillet	F 6-2	Studs	4.5.5
Fingernail Test	6.6.7	Tapped Hole Specifications	F 4-14
Fingernail Test	F 6-3	Threaded Fasteners	4.5.7
Flow Diagram for Identification of MIL-I-46058 Con-		Tight Fit	4.5.2.2
formal Coatings	F 6-1	Typical Chassis Punch	F 4-2
Identification Chart	6.6.3	Typical Drive Pins and Spring Pins	F 4-5
Inspection	6.6.4	Typical Retaining Rings	F 4-13
Preliminary Identification	6.6.1	Typical Scribe	F 4-1
Repair Sequence	T 6-2	Typical Studs and Terminals	F 4-12
Types of Coatings	6.6.2	MIXING AND PAINTING BACKGROUND	
Ultraviolet Fluorescence	6.6.5	INK	8.19
INITIAL TESTING (FRONT PANEL REMOVED FROM		MIXING AND PAINTING PRIMER INK	8.18
LRU)	8.8	O	
INSPECTION	2.10	OPERATING PROCEDURES	7.6
INSPECTION	8.7	Summary of ESD Periodic Testing Time	
Consumable Materials Required for Front Panel		Intervals	T 7-5
Repair	T 8-2	Typical ESD Protective Area Sign	F 7-15
INSULATING	2.5	P	
INSULATING MATERIALS	4.16	PARTS SUBSTITUTION	1.2
Coatings	4.16.1	PERIODIC TESTING OF ESD CONTROL	
Hand Crimping Tool, Aluminum Terminals	F 4-50	PRODUCTS	7.8
Hand Crimping Tools for Pre-Insulated		Compressed Air, Hot Air Blowers, Dry Nitrogen and	
Terminals	F 4-49	Vacuum Nozzle Ground Test Procedures	7.8.12
Heat-Shrinkable Tubing	4.16.3	Conductive/Static Dissipative Finger Cots and	
Inserting Terminal Lug Into Hand Tool	F 4-52	Gloves	7.8.9
Plastic Tape	4.16.4	Flooring Test Procedures	7.8.3
Power Crimping Tools	F 4-51	Footwear Test Procedures	7.8.5
Standard Insulation Tubing	4.16.2	Seating Test Procedures	7.8.7
Typical Heat-Shrinkable Tubing Sizes	T 4-6	Shielding Bag Test Procedures	7.8.8
M		Solder Gun or Iron Test Procedures	7.8.11
MARKING	2.7	Storage Cabinet and Shelf Test Procedures	7.8.2
MARKING AND IDENTIFICATION	4.22	Test Procedures for Bench Top Electrical	
MATERIALS	8.4	Ionizers	7.8.6
MATERIALS AND PARTS	1.1	Work Surface Test Procedures	7.8.1
MECHANICAL BONDING	2.4	Workstation Grounding Test Procedures	7.8.10
MECHANICAL FABRICATION	4.5	Wrist Strap Test Procedures	7.8.4
Acceptable and Unacceptable Eyelets	F 4-11	POTTING OF CONNECTORS	4.17

INDEX - CONTINUED

Subject	Paragraph, Figure, Table Number	Subject	Paragraph, Figure, Table Number
Wire Wrapping Technique	F 4-54	REPLACEMENT AND REPAIR OF PARTS	4.24
Wire Wrapping Tool in Use	F 4-53	Capacitors	4.24.5
PRESSURIZATION TEST.	4.21	Cathode Ray Tubes	4.24.10
PROTECTIVE COATING ACCEPTANCE.	6.10	Controls and Switches	4.24.14
R		Correct Wiring for Fuse Holders Containing Indicator Lights	F 4-64
RECOATING REPAIRED AREAS.	6.8	Correct Wiring of Instrument-Type Fuse Holder.	F 4-63
Acrylic Coating.	6.8.4	Cross Reference, Military and Commercial Fuses	T 4-9
Drying or Curing Schedule for Coating Material Ap- plied Near End of Work Life	F 6-9	Electron Tubes, General	4.24.9
Drying or Curing Schedule for Coating Material Ap- plied Shortly After Mixing	F 6-8	Fuse Holders.	4.24.2
Parylene Coated Boards	6.8.3	Fuses	4.24.1
Polyurethane Recoat System.	T 6-5	Inductors and Transformers	4.24.6
Polyurethane and Epoxy Coated Boards	6.8.2	Lamps	4.24.3
Removing Coatings and Fillets from Axial Components.	F 6-7	Limitations for CRT Dead Spots	T 4-10
Silicone Coated Boards	6.8.5	MIL-C-25955 Connectors, MIL-S-24251/3 Series.	4.24.12
Washing of Boards	6.8.1	Meters	4.24.8
RECOMMENDED TOOLS.	1.4	Military Fuse Designations.	F 4-62
Recommended Tools	T 1-1	Power Cords and Plugs.	4.24.13
REFERENCES	7.2	Relays	4.24.7
REMOVAL OF COATING	6.7	Repair of Power Cords	F 4-66
Acrylic	6.7.3	Resistors	4.24.4
Coating Repair Process	T 6-4	Semiconductor Devices	4.24.11
Color Test 2 Setup	F 6-4	Slow-Blow Fuse	F 4-61
Parylene.	6.7.2	Vibration Isolators	4.24.15
Polyurethane and Epoxy.	6.7.1	Wiring Diagrams For Indicator Type Fuse Holders	F 4-65
Removing Polyurethane Coating from Lead	F 6-5	REPLACEMENT OF FAULTY BULBS	8.13
Removing Polyurethane Coating or Fillets	F 6-6	S	
Silicone	6.7.4	SAFETY	4.2
REMOVAL, REPLACEMENT OF FILTER BRACKET, PILE FASTENERS AND ANNUNCIATORS	8.16	Chemicals	4.2.3
REMOVAL/REPLACEMENT OF FILTERS/ REFLECTORS	8.14	Electronics	4.2.4
Clinched Splice	F 8-3	Power Extension Cables	4.2.5
REPAIR AND REFINISHING.	2.6	Recommended Materials	T 4-1
REPAIR OF BROKEN BUSS WIRE	8.12	Rotating Machinery	4.2.2
Cracked Panel Repair	F 8-2	Work Area	4.2.1
Typical Stencil/Diagram.	F 8-1	SAFETY PRECAUTIONS	6.4
REPAIR OF BROKEN CORNERS.	8.11	Chemicals	6.4.3
REPAIR OF CRACKED OR BROKEN PANELS.	8.10	Electronics	6.4.4
REPAIR OF ELECTRICAL CONTACT STRIPS	4.26	Rotating Machinery	6.4.2
Areas of Use.	4.26.2	Work Area	6.4.1
Assembly of Cavity Resonators	4.26.8	SAFETY WIRING AND SAFETY CABLING	4.6
Description.	4.26.1	AN Connectors	4.6.8
Manufacturers of Preformed Finger Stock	4.26.5	Double Twist Method.	4.6.3
Missing or Bent Contacts	4.26.4	Double Twist Safety Wiring	F 4-17
Mounting of Finger Stock.	4.26.6	Gaskets	4.6.11.3
Plating	4.26.7	Installation	4.6.11.2
Problems	4.26.3	Material	4.6.1
REPAIR OF WAVEGUIDE	4.27	Nuts	4.6.11.5
Cure Cycle	4.27.1	Pre-installation Checks.	4.6.11.1
REPAIR SEQUENCE.	6.5	Single Wire Method.	4.6.4
		Single Wire Method	F 4-18

INDEX - CONTINUED

Subject	Paragraph, Figure, Table Number	Subject	Paragraph, Figure, Table Number
Solid-Shell Angle Plugs	4.6.10	Static Electricity	7.3.1
Split-Shell Assemblies	4.6.9	Typical Electrostatic Voltages Generated by Personnel	T 7-2
Tightness of Wire	4.6.7	Typical Sources of Static Electricity	T 7-1
Torque	4.6.11.4		
Twisting With Pliers	4.6.5	T	
Twisting With Special Tools	4.6.6	THERMAL BONDING	2.3
Twists Per Inch	4.6.2	TOOLS AND ACCESSORIES	8.3
Typical Lockwashers	F 4-16	TROUBLESHOOTING	4.23
Use of Wire Twister	F 4-19	TROUBLESHOOTING	8.9
V-Band Coupling Safety Wiring Techniques	F 4-20	TYPES OF FRONT PANELS	8.2
V-Band Couplings	4.6.11	Exterior Lighted Front Panels	8.2.1
SANDING	8.17	Illuminated Front Panels	8.2.2
SHIELDED AND COAXIAL CABLE	4.10	V	
Attaching Improved N Connectors to Coaxial Cable	F 4-29	VARNISH-TYPE COATINGS	6.11
Attaching Pigtail Wires to Cable Sheath	4.10.4	High-Voltage Circuits	6.11.2
Common-Point Pigtail Splice	F 4-32	Sealing	6.11.1
Connector Termination	4.10.2	W	
Emergency Splice	4.10.5	WELDING	4.8
Grounding Sheath Termination	4.10.3	WIRE WRAPPED ELECTRICAL CONNECTIONS	4.14
Grounding Sheath Termination for Shielded Wire	F 4-30	Procedure	4.14.2
Insulation Repair	4.10.6	Use	4.14.1
Removing Insulation	4.10.1	WIRING	2.2
Several Shields in One Set of Sleeves	F 4-33	WIRING	4.9
Shielded Wire Terminations, Inner Sleeves	T 4-3	Emergency Splicing	4.9.5
Shielded Wire Terminations, Outer Sleeves and Install- ing Tools	T 4-4	Marking	4.9.3
Shop Aids for Stripping Insulation from Coaxial Cables	F 4-28	Permanent Splicing	4.9.4
Soldered On Pigtail Preparation	F 4-31	Pre-Insulated Copper Splices and Crimping Tools	T 4-2
Stripping Coaxial Cable with Single Conductor Shield	4.10.7	Pre-Insulated Permanent Copper Splices	F 4-25
SILKSCREENING	8.20	Protection	4.9.2
SPECIAL MATERIALS	6.3	Splicing Broken Wire by Soldering	F 4-27
Special Materials for Conformal Coating	T 6-1	Terminal Lug Barrel Splice	F 4-26
SPECIAL TOOLS	6.2	Type of Wire	4.9.1
SUMMARY OF ESD PRINCIPLES	7.3	WIRING BULB LOCATION STENCILING	8.22
Catastrophic	7.3.5.1	WORK AREA ESD CONTROL SURVEYS	7.7
Common ESD Misconceptions	7.3.6	Background	7.7.1
Dielectric Failure in 3N157 MOSFET at 5000X	F 7-2	ESD Control Product Requirements	7.7.4
ESD Parameters	7.3.3	General	7.7.2
Failure Mechanisms	7.3.4	Performing Work Area ESD Control Surveys	7.7.3
Failure Types	7.3.5	Static Control Workstations	7.7.4.2
Intermittent	7.3.5.2	Test Benches	7.7.4.3
Latent	7.3.5.3	Unique Situations	7.7.4.5
Reasons for Device Failure Due to ESD	F 7-1	Work Area ESD Control Checklist	7.7.5
Sources of Static Electricity	7.3.2	Wrist Straps	7.7.4.4

