

**TO 00-25-172CL-3**

---

**TECHNICAL MANUAL  
CHECKLIST**

**HOT REFUELING OF U.S. NAVY AIRCRAFT  
(ATOS)**

BASIC AND ALL CHANGES HAVE BEEN MERGED  
TO MAKE THIS A COMPLETE PUBLICATION

**This Publication Augments TO 00-25-172.**

**DISTRIBUTION STATEMENT A** - Approved for public release; distribution is unlimited (WR-ALC/PA Cert. No. 04-10-74). Other request for this document shall be referred to 584 CBSS/GBMUDE, Robins AFB GA 31098. Questions concerning technical content shall be referred to 579 CBSS/GBZAB, Robins AFB GA 31098.

Published under authority of the Secretary of the Air Force

---

**22 OCTOBER 1990  
CHANGE 2 - 15 MAY 2006**

**TO 00-25-172CL-3****LIST OF EFFECTIVE PAGES**

Insert latest changed pages; dispose of superseded pages in accordance with applicable regulations.

**NOTE:** On a changed page, the portion of the text affected by the latest change is indicated by a vertical line, or other change symbol, in the outer margin of the page. Changes to illustrations are indicated by miniature pointing hands. Changes to wiring diagrams by shaded areas.

**Dates of issue for original and changed pages are:**

Original..... 0 ..... 22 October 1990  
 Change..... 1 ..... 26 August 2002  
 Change..... 2 ..... 15 May 2006

**Total number of pages in this manual is 64, consisting of the following:**

Page No.	*Change No.	Page No.	*Change No.	Page No.	*Change No.
<b>Title</b>					<b>2</b>
<b>A</b>					<b>2</b>
i					1
ii					<b>2</b>
<b>1-1</b>					<b>2</b>
1-2					0
<b>1-3</b>					<b>2</b>
1-4 - 1-7					0
1-8 Blank					0
2-1 - 2-6					0
3-1 - 3-6					0
4-1 - 4-5					0
4-6 Blank					0
5-1					0
<b>5-2 - 5-4</b>					<b>2</b>
<b>5-4.1</b> Added					<b>2</b>
<b>5-4.2</b> Blank					<b>2</b>
<b>5-5</b>					<b>2</b>
5-6 - 5-8					0
6-1 - 6-7					0
6-8 Blank					0
7-1 - 7-15					Added..1
7-16					Blank.....1

\*Zero in this column indicates an original page

**A Change 2**

**TABLE OF CONTENTS**

Section/Para	Page
INTRODUCTION.....	ii
I SUPPORT EQUIPMENT FOR HOT REFUELING OPERATIONS.....	1-1
II EA/A-6 HOT REFUELING PROCEDURES.....	2-1
III E-2 HOT REFUELING.....	3-1
IV F-14 HOT REFUELING PROCEDURES.....	4-1
V F-18 HOT REFUELING PROCEDURES.....	5-1
VI S-3 HOT REFUELING PROCEDURE.....	6-1
VII AV-8 HOT REFUELING PROCEDURES.....	7-1

**TO 00-25-172CL-3****INTRODUCTION****INTRODUCTION AND GENERAL INSTRUCTIONS**

In a wartime situation, U.S. Navy aircraft may land at USAF bases to refuel on its way to home base or carrier. The Navy aircraft may need to be hot refueled (i.e., refueled with an engine running) in order to minimize ground turnaround time and avoid the need for support equipment.

This checklist provides the procedures for hot refueling Navy aircraft. Applicable aircraft are the EA/A-6, A-7E, E-2, F-14, F-18, S-3 and AV-8. The E/A-6, E-2, F-14, and S-3 aircraft will shut down the right engine for hot refueling. This checklist is a step-by-step guide to accomplish the selected tasks. Although many details are present, this checklist is intended for use by fully qualified and trained hot refueling personnel only.

**TO 00-25-172CL-3**

## **SECTION I SUPPORT EQUIPMENT FOR HOT REFUELING OPERATIONS**

The following support equipment is required to follow the procedures set forth in this checklist:

Refueling Pantograph (GRU-17E or Solid State Stainless Steel) with Deadman Control

Fuel Source (R5/R9/R11/R12 Fuel Truck, Hydrant Fuel Pit, or Fuel Bladders)

Grounding and Bonding Wires

Fire Extinguisher, 150-lb Halon, or Equivalent

Crash/Fire/Rescue Vehicle

M32A-60 Power Cart, or Equivalent (For E-2 Aircraft Only)

Eye Protection (For E-2 Aircraft Only)

Hand Signalling Wands (For Night Operations)

Chocks

Intercom Cord with Adaptors (If available)

### **PERSONNEL AND PERSONNEL LOCATIONS**

<b>HRS (A MAN)</b>	Hot refueling supervisor. Stationed forward and to the right of the aircraft (approximately lined up with the nose and wingtip). Holds pantograph or hydrant deadman control. Maintains intercom (if available) with the aircrew.
------------------------	---

**Change 2 1-1**

**TO 00-25-172CL-3**

REO (B MAN)	Refueling equipment operator. Stationed at the truck or hydrant. Holds the fuel truck deadman control.
SPRM (C MAN)	Single point receptacle monitor. Stationed at the aircraft SPR and operates the aircraft refueling controls.
RA (D MAN)	Refueling assistant. Various locations. Attaches grounding/bonding wires, checks for hot brakes, checks aircraft vents for air flow, and monitors the pantograph for leaks.

**GENERAL PRECAUTIONS**

1. Hot refueling will only be done by properly trained and qualified personnel.
2. Only USAF-approved hot refueling equipment will be used.
3. Do not hot refuel aircraft with a hot brake condition.
4. Prior to hot refueling, all external tanks, stores, and weapons must be safed.
5. A major crash/fire/rescue vehicle must be on-scene during hot refueling (unless the site is equipped with a fixed fire extinguishing system).
6. The maximum refueling pressure is 55 psi.
7. Verify with the aircrew that fuel has not been dumped (jettisoned) on the previous flight. If fuel had been dumped and the position of the dump valve is not positively known to be closed, then aircraft will not be hot refueled.
8. Intercom will be used if available. Otherwise, the hand signals in Figure 1-1 will be used.
9. Aircraft high level shutoff valves must be pre-checked at the beginning of the hot refueling operation. If an aircraft fails any pre-check, the aircraft can only be cold refueled.

**TO 00-25-172CL-3**

10. During hot refueling, check that air is flowing from the aircraft fuel vent outlet(s) (except F-18). Navy external tank vents are on the bottoms of the external tanks.

11. If sufficient grounding receptacles are not available, attach a grounding clamp to any unpainted metal surface.

12. Avoid the tail hook area (bottom of fuselage near the aft end).

13. Do not touch any pitot tubes or probes which may be hot.

14. Avoid the areas underneath external tanks or stores until they are safed.

15. Many US Navy hot refueling operations employ the use of emergency dry-break disconnect devices for rapid taxi away in emergencies. USAF bases do not use this device, so NAVY pilots must be advised beforehand on current USAF hot refueling emergency procedures.

## TO 00-25-172CL-3

## REFUELING SIGNALS

## 1. TOP OFF



Pat top of head.

## 2. FUEL STATUS



Movement of thumb to mouth for requesting fuel on board.

## 3. PROBE OUT

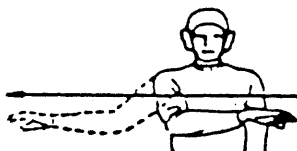

Arm across chest, then extend out horizontally.

## 4. PROBE IN PROBLEM

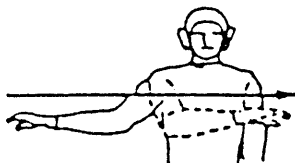

Arm extended out horizontally, then brought in to cross chest.

## 5. CLOSE DUMP VALVE



Point finger at elbow.

## 6. CUT FUEL



Fingers point at throat, moving hand sideways.

L9002986

Figure 1-1. Navy Hand Signals (Sheet 1 of 3)



FUEL QUANTITY SIGNALS \*

## FOR HUNDREDS OF POUNDS

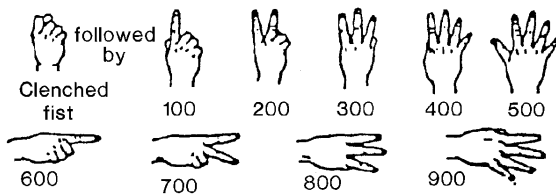

## FOR EVEN THOUSANDS OF POUNDS

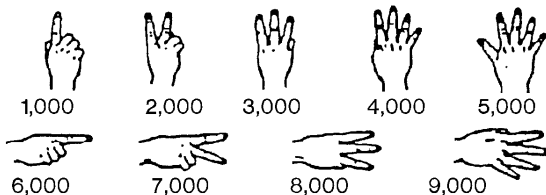

## FOR LOADS THAT DO NOT FALL ON EVEN THOUSANDS OF POUNDS

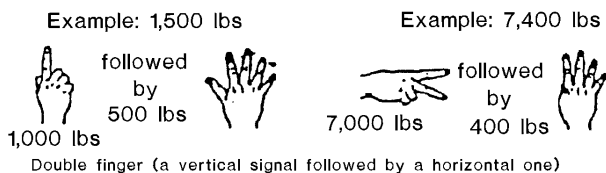

## FOR LOADS OF TEN THOUSANDS OF POUNDS AND OVER

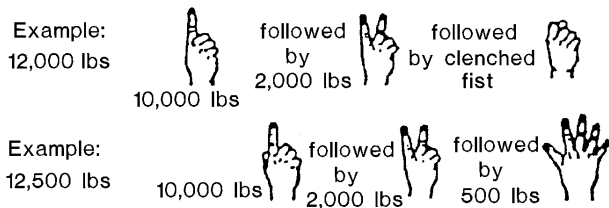

Double finger (a vertical signal followed by a horizontal one) followed by a clenched fist for exact thousands, or a third finger signal for hundreds.

L9003062

Figure 1-1. Navy Hand Signals (Sheet 2 of 3)

TO 00-25-172CL-3

## SIGNALS

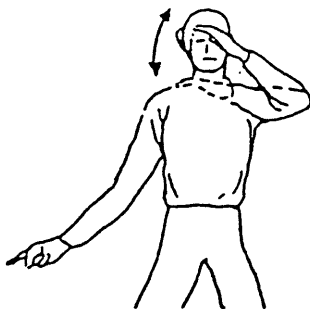

## HOT BRAKES

DAY	NIGHT
Makes rapid fanning motion with one hand in front of face and points to wheel with other hand.	Same as day except with wands.

REMARKS

L9003063

*Figure 1-1. Navy Hand Signals (Sheet 3 of 3)*

## EMERGENCY PROCEDURES

If a fire or fuel leak occurs at the aircraft:

1. Stop fuel flow at the source.
2. Notify the aircrew of the emergency and to stop aircraft engine(s) and auxiliary power units (APUs).
3. Notify the fire department.
4. Evacuate all personnel (including the aircrew other than fire guards).
5. If leak: Fire guards will stand by with portable extinguisher nozzles in hand until the fire department arrives.
6. If fire: Fire guards will attempt to extinguish the fire until fire department arrives or until munitions are engulfed in flame (in this case, immediately withdraw at least 4000 feet).

If a fire occurs at another location in the area:

1. Stop fuel flow at source and at the nozzle.
2. Disconnect nozzle, intercom, and ground wires. Remove chocks.
3. Signal the aircrew to taxi the aircraft clear of the area.
4. Fire guards will assist in fire fighting until the fire department arrives.



## SECTION II

### EA/A-6 HOT REFUELING PROCEDURES

The single point receptacle (SPR) is located on the lower part of the right engine nacelle about 2.5 feet aft of the engine inlet. The fueling control panel (station) is immediately aft of the right nacelle boarding ladder at approximately eye level. Figure 2-1 shows the refueling station switches that control fuel flow into the three fuselage tanks, five wing tanks, and up to four external tanks. Total internal fuel capacity is 2344 gallons; each external fuel tank holds an additional 300 gallons. Aircraft fuel dump outlets are located on the wing trailing edges near the wingtips and at the aft end of the fuselage. Fuel vent outlets are located in the aft fuselage and on the undersides of the wings near the wingtips. (The wingtip vents are used only when the wings are folded). Three fuel tank overpressurization lights are located on the fueling station door to warn of impending fuel tank overpressurization. The aircraft has no on board auxiliary power unit (APU) or self-start capability, but one engine can start the other. The A-6 aircraft SPR panel receives electrical power from the right engine only, so A-6 aircraft cannot be hot refueled at USAF bases until the entire fleet is modified to provide electrical power to the SPR panel from the left engine. EA-6 aircraft can be hot refueled with the right engine shut down because the left engine can provide electrical power to the SPR panel.

TO 00-25-172CL-3

**WARNING**

- Do not hot refuel following aerial refueling operations until a positive check has been made to ascertain the aerial refueling probe has not been damaged.
- During refueling, tank overpressure indicator lights on the fueling station door must be monitored to prevent rupture of the fuel tanks. If one or more of these lights illuminate during fueling, refueling must be stopped immediately and the cause of the overpressure must be corrected before refueling may be resumed.
- Only EA-6 aircraft can be hot refueled at USAF bases.

**CURSORY INSPECTION**

1. Stop the aircraft at least 50 feet short of the hot refueling area.
2. Signal the aircrew to shut down the right engine.
3. Check for hot brakes.
4. Verify all weapons, external tanks and stores have been safed. If they have not been safed, open the left crew access ladder door and remove the pins from the storage compartment. Install the pins.
5. Verify the fuel dump (jettison) valve is closed.
6. If aerial refueling operations have occurred since the last ground refueling, visually inspect the bullet shaped plug at the end of the refueling probe to ascertain that the bullet plug is properly aligned with the probe. An angle alignment indicates the plug is not properly seated and that a fuel spill is likely to occur during the refueling cycle. Do not proceed with hot refueling, if the bullet plug is not properly aligned.

7. Signal the aircrew to spread wings.
8. Signal the aircrew to taxi to the hot refueling area.

#### REFUELING

1. Position the aircraft on the hot refueling pit.
2. Chock and ground (clamp) the aircraft.
3. If available, connect the intercom (usually at the SPR panel).
4. Ensure DUMP circuit breaker (on nose wheel well circuit breaker panel) is engaged (A-6 only).
5. Prior to refueling, check that no air is flowing from the external fuel tank vents (on the bottom of the external tanks). This verifies that engine bleed air is not pressurizing the tanks.
6. On the FUELING STATION panel, set the POWER switch to FUEL, and set the WING TANKS, FUS TANKS, and DROP TANKS switches to FUEL.

**CAUTION**

If the indicators checked in steps 7 and 8 malfunction, do not refuel the aircraft.

7. On the fueling station access door, press the OUTER HIGH PRESS indicator FUSELAGE HIGH PRESS, INNER HIGH PRESS, and OUTER HIGH PRESS lights should illuminate; if not, stop refueling.
8. On the FUELING STATION panel, momentarily press each WING TANKS, FUS TANKS, and DROP TANKS indicator that is not lighted; each indicator should illuminate when pressed; if not, stop refueling.
9. Ground the refueling equipment and bond to the aircraft.

TO 00-25-172CL-3

**WARNING**

Prior to pressurizing the fuel source, verify the nozzle is locked onto the aircraft by attempting to remove the nozzle with the flow handle open. If you can remove the nozzle, do not start the refueling until the nozzle is replaced.

10. Remove the dust cap from the fueling adapter and connect the fueling nozzle to the adapter and open the flow handle. Attempt to remove the nozzle with the flow handle in the open position.

11. Start fueling the aircraft; immediately set and hold the SOL CHECK switch to PRI. All WING TANKS PRI, FUS TANKS PRI, and DROP TANKS PRI indicators should go out and fueling automatically stop prior to the aircraft receiving 45 gallons of fuel (10 to 15 seconds). If this does not occur, discontinue the fueling operation.

12. When the fuel flow stops, check flow rate. If the flow rate exceeds 3 gallons or 20 pounds per minute, shut off the fueling unit and disconnect the fuel nozzle.

13. On the FUELING STATION panel, set the DROP TANKS switches to HOLD and release the SOL CHECK switch.

14. When the fuel flow starts, immediately set and hold the SOL CHECK switch to SEC. All WING TANK SEC and FUS TANKS SEC indicators should go out and fueling will automatically stop prior to aircraft receiving 30 gallons or 200 pounds of fuel. If this does not occur, discontinue the fueling operation.

15. When the fuel flow stops, check flow rate. If the flow rate exceeds 3 gallons or 20 pounds per minute, shut off the fueling unit and disconnect the fuel nozzle.



16. On the FUELING STATION panel, set the WING TANKS switches to HOLD and release the SOL CHECK switch.
17. Check the aerial refueling probe for leaking.
18. Check for airflow from the fuel vents. (Airflow should be present as the tanks fill.)

CAUTION
---------

If any of the three high pressure indicators illuminate during the fueling, fueling must be stopped immediately and the cause of the vent system overpressure corrected before the fueling is resumed.

19. Fuel the fuselage tanks until the FUS TANK indicators on the FUELING STATION panel go out.
20. On the FUELING STATION panel, set the WING TANKS switches to FUEL. On aircraft with external fuel tanks, set the DROP TANKS switches to FUEL. When the WING TANKS, FUS TANKS, and DROP TANKS indicators are all out, the aircraft is refueled.
21. On the FUELING STATION panel, set the POWER switch to OFF.
22. Shut off the fueling unit and disconnect the nozzle. Replace the dust cap on the fueling nozzle adapter.
23. Close and secure the FUELING STATION door.
24. Disconnect the intercom and the grounding/  
bonding cables.
25. Remove the safety pins and replace in the board-  
ladder stowage compartment.
26. Remove the chocks and direct the aircrew to taxi  
away from the area.

TO 00-25-172CL-3

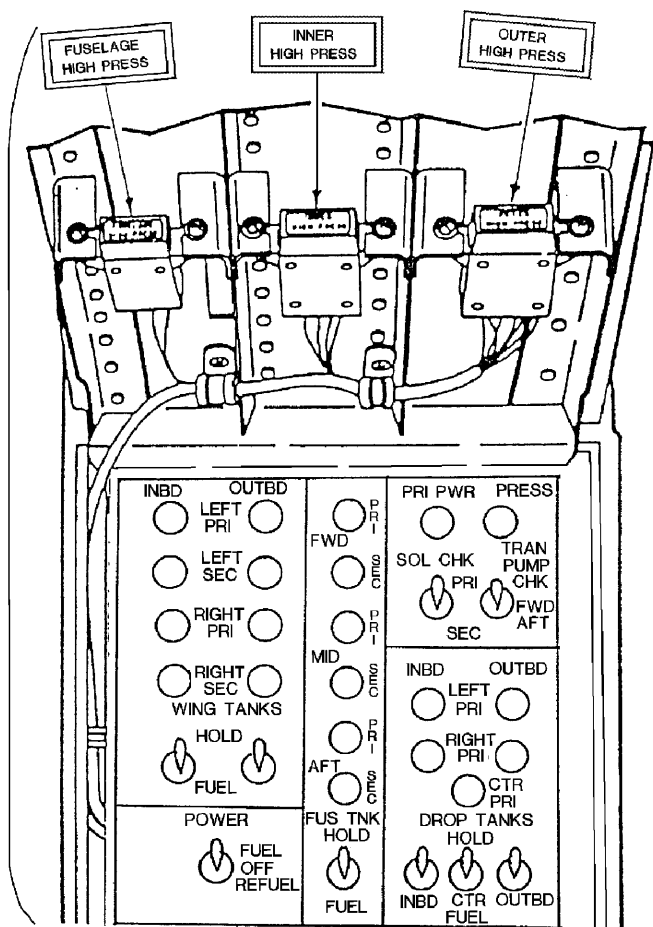

L9002987

Figure 2-1. A-6 Fueling Station Panel

### SECTION III

## E-2 HOT REFUELING

The single point receptacle and refueling control panel (Figure 3-1) are located on the inboard side of the right engine nacelle. The NOT FULL lights illuminate to indicate fuel is flowing into the tank. The pre-check will test both the primary and secondary floats in each high level shutoff valve. Fuel is carried in two wing tanks with a total capacity of 824 gallons. There are no external fuel tanks or weapons. The fuel vent and dump outlets are at the extreme aft end of the fuselage. If a tank overfills, the vent system cannot handle the excess flow, so the fuel will spray from one of the fuel tank relief valves on top of the wing at the outboard end of the fuel tank. This sprayed fuel might reach an engine exhaust, so to further prevent overfilling, refuel flow must be stopped when the pilot signals a tank has reached 200 pounds less than full.

The aircraft has no on board auxiliary power unit (APU) and except for newer models, one engine cannot start the other. Therefore, a ground power cart is needed.

### CURSORY INSPECTION

**WARNING**

The E-2 is a turboprop aircraft. Be constantly aware of the rotating propellers. Do not walk forward of the wings unless you are outboard of the wingtips. Due to propwash, the SPR monitor must wear eye protection.

1. Stop the aircraft at least 50 feet short of the hot refueling area.

TO 00-25-172CL-3

**WARNING**

- Due to the crash fire rescue limitations with E-2 aircraft with wings folded, this aircraft will not be hot refueled unless the wings are in the fully extended position.
  - Ensure the area is clear prior to spreading (unfolding) the wings.
2. Signal the aircrew to spread the wings.
  3. Check for hot brakes. When moving from one wheel to the other, walk to the wingtips prior to going forward. Walk well in front of the aircraft.
  4. Verify the fuel dump (jettison) valve is closed.
  5. Signal the aircrew to shut down the right engine.
  6. Signal the pilot to taxi to the hot refueling area.

**REFUELING**

1. Position the aircraft on the hot refueling pit.
2. Chock and ground the aircraft. (Grounding receptacles are located near the SPR and on the right center fuselage at eye level.)

**CAUTION**

Avoid the cooling fan on the fuselage, just inboard of the SPR.

3. Open the PRESS FUE STA access door (inboard side of right engine nacelle) and check the left and right strainer bypass lights. If either is illuminated, signal the aircrew to shut down the left engine, and notify aircrew of the situation.

4. Ground the refueling equipment and bond to the aircraft. Route the refueling equipment behind the right main landing gear.

**WARNING**

Prior to pressurizing the fuel source, verify the nozzle is locked onto the aircraft by attempting to remove the nozzle with the flow handle open. If you can remove the nozzle, do not start refueling until the nozzle is replaced.

5. Remove the dust cap from the pressure fueling adaptor, and connect the fueling nozzle. Rotate the nozzle flow handle to the open position and attempt to remove the nozzle.

6. Begin the fueling. Both NOT FULL lights should illuminate indicating that fuel is entering the tanks.

7. Hold the left TANK PRE-CHECK switch to PRIM. After the left NOT FULL LIGHT goes out (approximately 3 seconds later) hold the right TANK PRE-CHECK switch to SEC. After the right NOT FULL LIGHT goes out, the fueling should terminate, if this does not occur, discontinue the refueling operation. If fuel flow stops, release the switches and continue fueling.

8. Hold the left TANK PRE-CHECK switch to SEC and the right TANK PRE-CHECK to PRIM. If fuel flow does not stop when NOT FULL lights go out, turn off fueling source immediately and disconnect pressure fueling nozzle.

TO 00-25-172CL-3

WARNING

Because failure of a fuel shutoff valve could result in fuel being sprayed from the fuel tank pressure relief valve (on top of the wing above each nacelle) onto the hot exhaust area of the tailpipe, the possibility of causing a fire exists. Hot refueling must be stopped when either tank reaches 200 pounds less than full.

9. Continue refueling. SPRM will monitor the NOT FULL lights and the HRS will watch attentively the aircrew for the cutoff signal, and release the deadman control immediately when the cutoff signal is received.

10. When the fuel flow is stopped, shut off the refueling unit and disconnect the nozzle. Install the dust cap. Remove the fueling equipment.

11. Close and secure the PRESS FUE STA access door.

12. If needed, connect the M32A-60 or equivalent air/power source air hose to the ground air start station (inside the right main landing gear wheel well).

WARNING

Avoid the rotating propeller.

13. Signal the aircrew to start the right engine.

14. Disconnect the power cart and remove from the aircraft.

15. Remove the grounding/bonding wires.

16. Remove the chocks and signal the pilot to taxi away from the area.

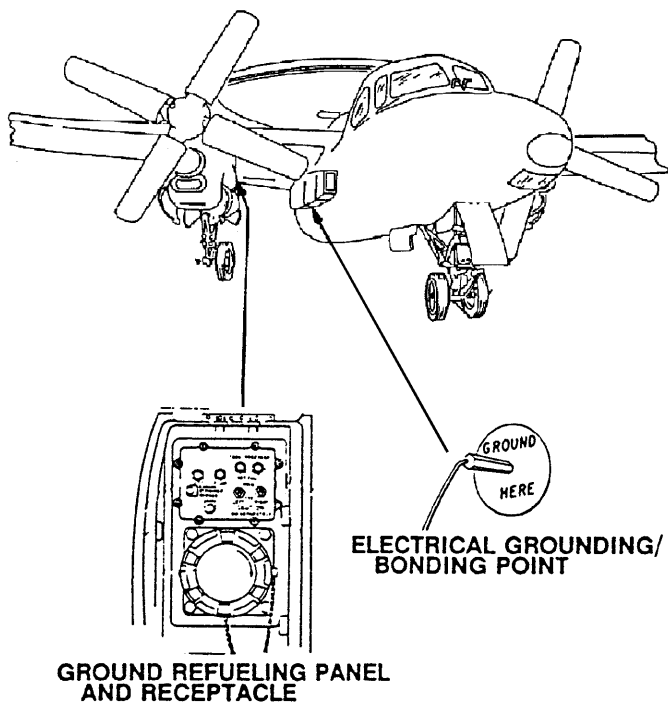

L9002988

*Figure 3-1. E-2 Refueling Provisions (Sheet 1 of 2)*

TO 00-25-172CL-3

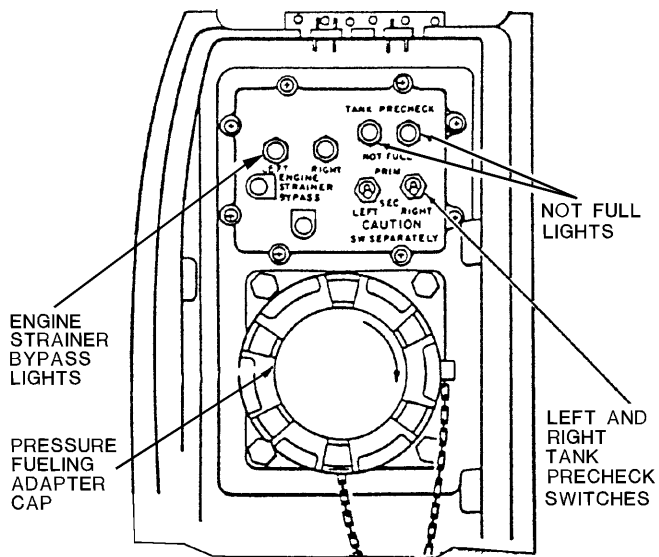

L9002989

Figure 3-1. E-2 Refueling Provisions (Sheet 2 of 2)



## SECTION IV

### F-14 HOT REFUELING PROCEDURES

The single point receptacle (SPR) is on the right side of the fuselage at eye level and 16 feet forward of the right engine inlet. The SPR panel (Figure 4-1) includes a REFUEL/TRANSFER switch, two pre-check switches (FUS TANKS and WING/EXT TANKS) and a fuel vent pressure gauge. The fuel vent pressure gauge consists of a pointer on a scale having a green (safe) band and a red (danger) band. The aircraft has eight fuselage fuel tanks two wing box tanks, two integral wing tanks, and two external fuel tanks. Total internal capacity is 2385 gallons, while each external tank holds 267 gallons.

The aircraft fuel dump (jettison) outlet is located on the boat tail between and forward of the engine exhausts. The internal fuel tanks are vented through an outlet on the bottom of the fuselage just forward of the tail hook pivot. The external fuel tanks are vented through outlets on the tank bottoms.

The aircraft has no on board auxiliary power unit or self-start capability, but either engine can start the other. Refueling can be done with the wings swept forward or aft.

#### CURSORY INSPECTION

1. Stop the aircraft at least 50 feet short of the hot refueling area.
2. Signal the aircrew to shut down the right engine.
3. Check for hot brakes.
4. Verify all weapons and external tanks have been safed. The external tanks use integral safing levers (Figure 4-2) instead of pins.
5. Verify the fuel dump (jettison) valve is closed.

TO 00-25-172CL-3

6. Signal the aircrew to taxi to the hot refueling area.

#### REFUELING

1. Position the aircraft on the hot refueling pit.
2. Chock and ground (clamp) the aircraft.
3. Prior to refueling, check that no air is flowing from the external fuel tank vents (on bottom of the external tanks). This verifies that engine bleed air is not pressurizing the tanks.
  4. Open the SPR panel door (on the right fuselage).
  5. Ground the refueling equipment and bond to the aircraft. (Use the grounding receptacle at the SPR panel.)
  6. If available, connect the intercom (in nose wheel well).

**WARNING**

Prior to pressurizing the fuel source, verify the nozzle is locked onto the aircraft by attempting to remove the nozzle with the flow handle open. If you can remove the nozzle, do not start refueling until the nozzle is replaced.

7. Remove the dust cap from the SPR adaptor, connect the fueling nozzle, and open the flow handle. Attempt to remove the nozzle with the flow handle in the open position.

**CAUTION**

If the pre-checks do not automatically stop fuel flow, do not hot refuel the aircraft.

8. Verify DEFUEL/TRANSFER switch is in the NORM position.
9. Begin the fuel flow.
10. Pre-check the refuel system. Place both selector valves to the STOP FUEL position at the same time. Fuel flow should stop within 30 seconds. If this does not occur, discontinue the refueling operation.
11. Place both selector valves to the FUEL position, and continue the refueling.
12. Check for air flow from the fuel vents, airflow should be present as the tanks fill. Avoid the tail hook area.

**WARNING**

Monitor the fuel vent pressure indicator and stop the refueling if the pressure indicates in the red band (above 4 psi).

13. Monitor the vent pressure indicator during the refueling operation.
14. When the fuel flow stops (tanks filled), shut off the fuel source and disconnect the nozzle.
15. Remove the grounding/bonding wires and the intercom.
16. Unsafe the external tanks.
17. Close and secure the SPR panel.

**TO 00-25-172CL-3**

**18. Remove the chocks and signal the aircrew to taxi away from the area.**

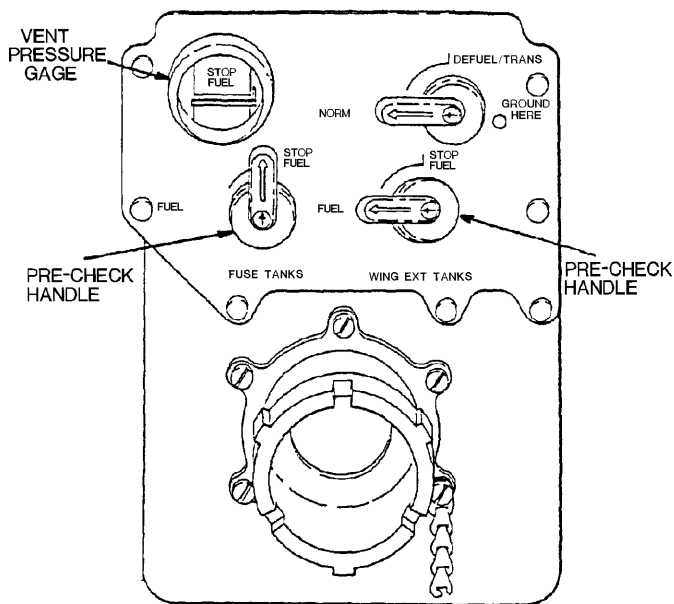

L9002990

Figure 4-1. F-14 Single Point Receptacle



## SECTION V

### F-18 HOT REFUELING PROCEDURES

The single point receptacle (SPR) is on the right side of the forward fuselage about 17 feet forward of the right engine inlet. Figure 5-1 shows the SPR panel which includes pre-check switches, a rotating fuel flow indicator, and a tank pressure gauge (with a green safe zone and a red danger zone). F-18C/D aircraft also include a REFUEL TEST switch (which will not be used during hot refueling) and a VENT TANK WET light with a test switch.

The fuel dump outlets are on the trailing edges of the vertical stabilizers, while the external tanks have their own vents at the tank bottoms. Total internal fuel capacity (in four fuselage tanks and two wet wing tanks) is 1589 gallons. Each of three external tanks carries 315 or 330 gallons.

The aircraft has a self-start capability provided by an on board jet fuel starter (JFS) which is not operated during refueling.

## **TO 00-25-172CL-3**

### **CURSORY INSPECTION**

1. Stop the aircraft at least 50 feet short of the hot refueling area.
2. Check for hot brakes.
3. Verify all weapons and external tanks have been safed. Ensure the external fuel tank safety select (Figure 5-2) is in the LOCKED position.
4. Verify the fuel dump (jettison) valve is closed.
5. Signal the aircrew to taxi to the hot refueling area.

### **REFUELING**

1. Position the aircraft on the hot refueling pit.
2. Deleted.
3. Chock and ground the aircraft. Use an approved grounding clamp on an unpainted surface.



**TO 00-25-172CL-3**

**WARNING**

When the right engine is operating, keep all personnel and refueling equipment at least 15 feet from the engine intake. Do not allow the right engine to be operated above the idle power setting.

4. Open the SPR door No. 8 on the right side of the forward fuselage and remove the SPR dust cap.
5. If available, connect the intercom (near SPR).
6. Check that no air is flowing from the external fuel tank vent outlets (on the bottom of the tanks). This verifies that the engine bleed air is not pressurizing the tanks.
7. Ground the refueling equipment and bond to the aircraft using the grounding receptacle in the SPR panel.

**Change 2 5-3**

**TO 00-25-172CL-3**

**WARNING**

Prior to pressurizing the fuel source, verify the nozzle is locked onto the aircraft by attempting to remove the nozzle with the flow handle open. If you can remove the nozzle, do not start the refueling until the nozzle is replaced.

8. Connect the nozzle to the SPR adaptor and open the nozzle flow handle. Attempt to remove the nozzle with the flow handle in the open position.

9. (F-18C/D only.) Press the VENT TANK SNSR TEST switch and observe the VENT TANK WET light illuminate. If the light fails to illuminate, do not hot refuel the aircraft.

10. Begin fuel flow and place the red master pre-check handle to the UP PRE-CHECK position.

11. Approximately 30 seconds later, place the external fuel tank pre-check switches to the pre-check positions:

a. On F-18A/B S/N 161353 thru 161761, press and hold the L, R, and C F TK CHECK switches.

b. On F-18A/B S/N 161924 and up, press and hold the EXT TX PRCHKSW.

**TO 00-25-172CL-3**

c. On F-18C/D, press and hold the EXT TANK PRE CHK switch to pre-check.

12. Fuel flow should stop 10 to 30 seconds later (check the fuel flow indicator). If the fuel flow does not stop, discontinue the hot refueling.

13. Release the external fuel tank pre-check switches and place the master pre-check handle to the DOWN OFF position. Fuel flow should begin.

**WARNING**

Monitor the fuel vents on the vertical stabilizers for fuel spills.

14. Monitor the fuel vent outlets and stop fuel flow if fuel spills from either vent outlet.

**WARNING**

Monitor the fuel tank pressure indicator and stop all refueling flow if the indicator shows red.

15. Monitor the fuel tank pressure indicator during refueling.



**TO 00-25-172CL-3**

**WARNING**

(F-18C/D only.) If the VENT TANK WET light illuminates, fuel may spill from the vent outlet(s).

16. (F-18C/D only) Monitor the VENT TANK WET light. If it illuminates, immediately discontinue the hot refueling.

17. Check the external fuel tank vents for air-flow as the tanks fill.

18. When the fuel flow stops, shut off the fuel at the source and disconnect the nozzle. Replace the dust cap on the SPR adaptor.

19. Remove the grounding/bonding wires.

20. Disconnect the intercom and close door No. 8. Do not catch the SPR dust cap chain in the door.

21. Deleted.

22. Remove the chocks and signal the aircrew to taxi away from the area.

**Change 2 5-5**

TO 00-25-172CL-3

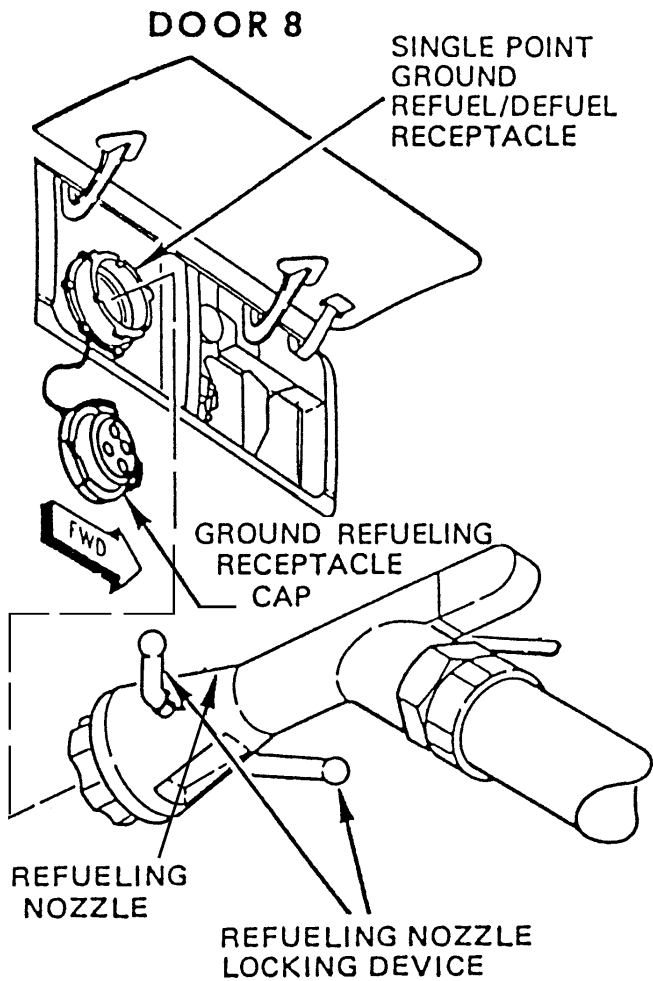

L9002992

Figure 5-1. F-18 Refueling Provisions (Sheet 1 of 2)

TANK PRESSURE/  
FUEL FLOW INDICATOR

FUEL CHECK  
PANEL

FWD →

A

ELECTRICAL  
GROUNDING  
JACK

MASTER PRECHECK  
HANDLE

F/A-18C/D

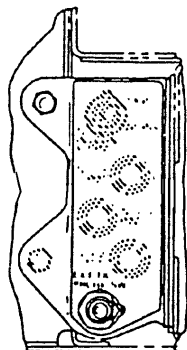

161924 thru 163175

DETAIL A

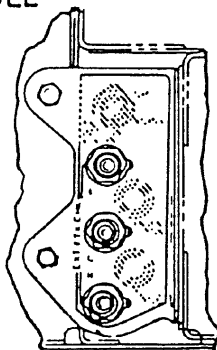

161353 thru 161761

L9002993

Figure 5-1. F-18 Refueling Provisions (Sheet 2 of 2)

TO 00-25-172CL-3

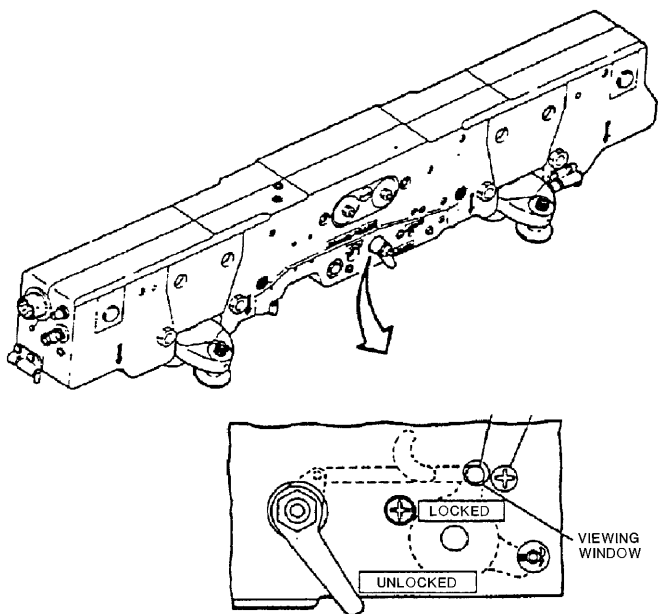

L9002994

Figure 5-2. F-18 External Tank Safing Mechanism



## SECTION VI

### S-3 HOT REFUELING PROCEDURE

The single point receptacle (SPR) is located on the right side of the fuselage immediately aft of the main landing gear well (Figure 6-1). Manual pre-check controls and the tank pressure gauge are located in the right main wheel well "around the corner" from the SPR. The aircraft can carry 1933 gallons in four internal fuel tanks in the center wing section (inboard of the wing folds) and 265 gallons in each of two external fuel tanks. The external tanks have no pre-check capability, but can be hot refueled. Internal tanks are vented through a single outlet at the aft end of the fuselage, while the external tanks are vented at the tank bottoms. A single fuel dump (jettison) chute is located at the fuselage aft end.

The aircraft has an on board auxiliary power unit (APU) with an exhaust port on the fuselage left side (near the running engine). The APU can be running during hot refueling. The right engine is shut down during hot refueling.

The aircraft carries up to 46 sonobuoys that are launched from tubes on the bottom aft fuselage. Prior to refueling, these sonobuoys are safed by opening a small door just forward of the left hand sonobuoy chutes. The door has a link that operates a safing switch.

#### CURSORY INSPECTION

1. Stop the aircraft at least 50 feet short of the hot refueling area.

TO 00-25-172CL-3

**WARNING**

Do not hot refuel with the wings folded.

2. Signal the aircrew to spread the wings.
3. Signal the aircrew to shut down the right engine.
4. Check for hot brakes.
5. Verify all external weapons and external tanks have been safed. Ensure the external fuel tank locking indicator (Figure 6-2) is in the LOCK position.
6. Verify the fuel dump (jettison) valve is closed.

**WARNING**

Avoid the tail hook area when working beneath the aircraft.

7. Open the sonobuoy safing door (on the fuselage bottom) just forward of the left hand sonobuoy chutes. Check the safing link for integrity. (There are two links—one for holding the door and the other for operating the safing switch).

8. Signal the aircrew to taxi to the hot refueling area.

**REFUELING**

1. Position the aircraft on the hot refueling pit.
2. Chock and ground the aircraft. (A grounding point is located on the bottom of the fuselage about three feet aft of the nose gear door.)
3. If available, connect the intercom (on the nose wheel door).

4. Check that no air is flowing from the external fuel tank vents. This verifies that engine bleed air is not pressurizing the external tanks.

WARNING

Prior to pressurizing the fuel source, verify the nozzle is locked onto the aircraft by attempting to remove the nozzle with the flow handle open. If you can remove the nozzle, do not start the refueling until the nozzle is replaced.

5. Bring the fueling equipment behind the right engine and attach the nozzle to the SPR. Open the nozzle flow handle and attempt to remove the nozzle with the flow handle in the open position.

6. Verify that the external tank fueling switch (at the SPR) is OFF.

7. Begin the refueling. Rotate and hold both pre-check valves to the vertical (open) position at the same time. (The switches are spring-loaded to the horizontal (closed) position). Fuel flow should stop within 20 seconds. If fuel flow does not stop, discontinue the hot refueling.

8. After the internal fuel tanks have completed their pre-check, release the pre-check valves and position the external tank fueling switch to ON.

WARNING

Stop the hot refueling operation if the tank pressure gauge reaches the red zone.

9. Observe the tank pressure gauge as the tanks fill.

TO 00-25-172CL-3

10. As the fuel tanks fill, check for air flowing from the vent outlets.

11. When the tanks are full, turn off the fuel at the source and disconnect the nozzle.

12. Position the external tank fueling switch to OFF.

13. Disconnect the grounding/bonding wires and the intercom. Secure the SPR panel.

WARNING

Avoid the tail hook area when working beneath the aircraft.

14. Close the sonobuoy safing door.

15. Remove the chocks and signal the aircrew to taxi away from area.

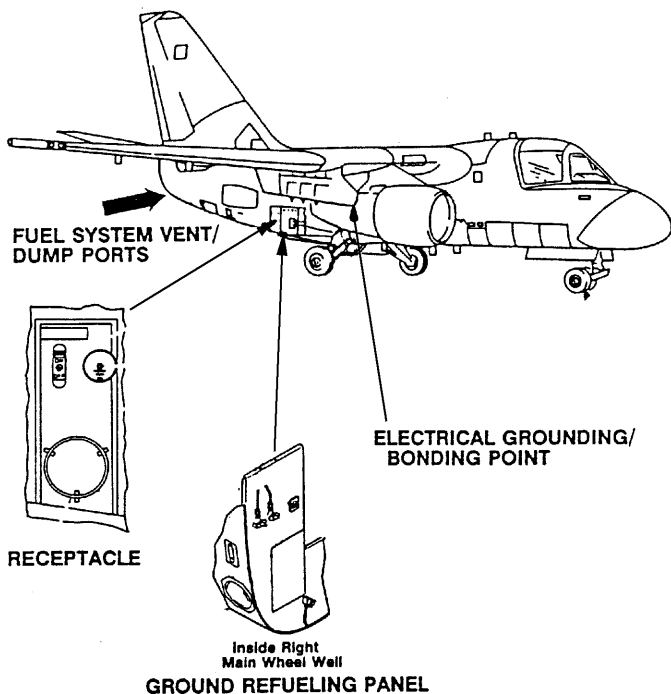

L9002995

Figure 6-1. S-3 Refueling Provisions (Sheet 1 of 2)

TO 00-25-172CL-3

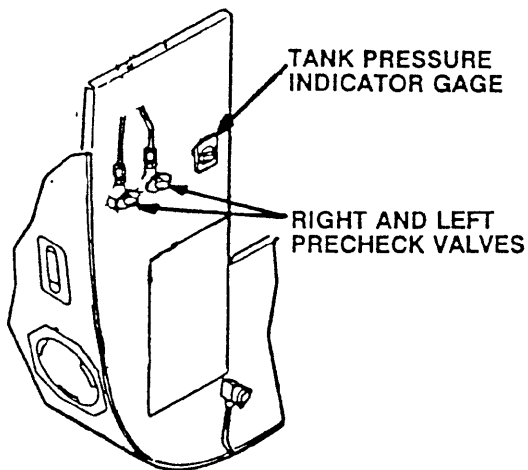

Inside Right  
Main Wheel Well

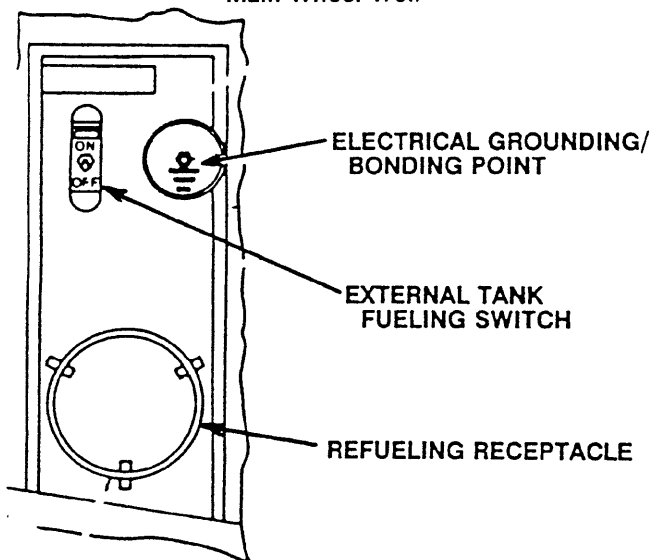

L9002996

Figure 6-1. S-3 Refueling Provisions (Sheet 2 of 2)

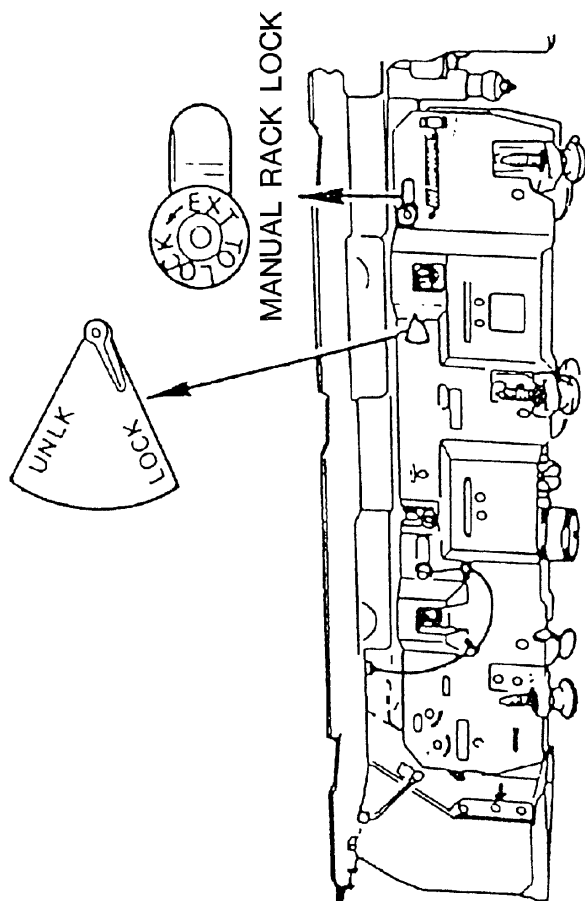

L9002997

Figure 6-2. S-3 External Tank Safing Indicator





## SECTION VII

### AV-8 HOT REFUELING PROCEDURES

#### REFUELING/DEFUELING

The aircraft is refueled/defueled through a standard refuel/defuel receptacle located below Door 22 on the left forward fuselage. Ground refueling controls and indicators and the intercom connection are inside Door 22. The maximum refueling pressure is 55 psi. All tanks are vented through the vent mast on lower right side of fuselage, below the right front nozzle. Use of the intercom is preferred, but not mandatory. The diagrams at the end of this chapter show the ground refueling provisions and the armament safing provisions.

TO 00-25-172CL-3

## REFUELING PRECAUTIONS

### WARNING

- Failure to comply with the precautions below could result in injury or death to personnel.
  - Aviation turbine fuel is flammable and toxic to eyes, skin, and respiratory tract. Skin/eye protection is required. Avoid repeated/prolonged contact. Use only in well ventilated areas. Keep away from open flames or other sources of ignition.
1. Do not refuel aircraft with suspected hot brakes.
  2. Make sure aircraft fuel servicing equipment and external electrical power source are grounded.
  3. Make sure enough fire fighting equipment is available (TO 00-25-172).
  4. Inspect refueling nozzle locking device to make sure aircraft ground refueling receptacle is serviceable.
  5. Make sure vent mast is not obstructed.
  6. Make sure refueling is not done within 300 feet of ground radar equipment.
  7. Make sure refueling is not done within 50 feet of other aircraft with engine(s) operating.

8. Operation of the auxiliary power unit (APU) is prohibited during normal refueling.
9. Do not carry or wear loose metal objects, such as knives, keys, or other objects which might cause sparks.
10. Never fuel or defuel during electrical storms.
11. Do not carry matches or cigarette lighters.
12. Do not wear shoes with exposed nails, metal plates or hobnails.
13. Make sure aircraft is chocked.

#### NOTE

Safetied means installation of any arming lever, safety pin, electrical interrupt, plug pin, securing of armament switches and/or any applicable action which makes the specific ordnance carried safe.

14. All ordnance will be safetied.
15. Fuel pressure from servicing equipment should not exceed 55 psi, during normal refueling.
16. Make sure aircraft is receiving correct fuel (JP-4, JP-5 or JP-8).

#### REFUELING PROCEDURE

1. Attach intercom cord and determine quantity of fuel required.
2. Observe all refueling precautions. Avoid the engine inlet.

TO 00-25-172CL-3

**WARNING**

To prevent injury to personnel or damage to aircraft from possible static electricity discharge, all personnel involved in refueling shall dissipate static potential by gripping grounding wire before starting refueling operation and repeating frequently during refueling operation.

3. Static bond aircraft and refueling equipment. (Bonding receptacle is on left side of the aircraft near the SPR.)
4. On FUEL control panel assembly, make sure WING dump switches are in NORM position.
5. Remove ground refuel/defuel receptacle cap. On cap equipped with locking lever, press lever to unlock cap during removal.
6. Insert refueling/defueling nozzle in ground refuel/defuel receptacle by pushing and turning clockwise.

**WARNING**

To prevent spillage, resulting in possible fire and/or explosion, make sure nozzle is in locked position.

7. Make sure refueling nozzle is fully engaged by turning clockwise until nozzle resists turning. Lock nozzle in position by positioning nozzle manual fuel shutoff lever in full open position.
8. Inspect refueling nozzle engagement by a counterclockwise tug on nozzle handles. Determine refueling hose quick disconnect fitting engagement by pulling on hose and visual inspection.
9. Make sure aircraft is receiving the correct fuel (JP-4, JP-5 or JP-8).
10. Open Door 22.
11. If required, set EXTERNAL TANK LOCKOUT switch to LOCKOUT position.

**WARNING**

To prevent injury to personnel and damage to equipment, do not refuel aircraft, if TANK OVER PRESS warning lamp is inoperative.

12. Press-to-test TANK OVER PRESS (red) warning light for lamp operation.

TO 00-25-172CL-3

13. On external fuel control panel assembly, set LEFT and RIGHT REFUEL switches to the SHUT OFF position (toggles up).

WARNING

To prevent injury to personnel and damage to fuel system, fuel pressure from servicing equipment shall not exceed 55 psi.

14. Apply 55 psi refueling pressure.

WARNING

To prevent injury to personnel and damage to equipment, do not attempt to refuel aircraft if fuel enters tanks.

15. Make sure REFUEL VALVES are closed preventing fuel from entering fuel tanks, with refueling pressure applied.
16. Remove 55 psi refueling pressure.
17. Set LEFT and RIGHT REFUEL switches to REFUEL position (toggles down).

WARNING

To prevent injury to personnel and damage to equipment, do not exceed 55 psi refueling pressure.

18. Apply 55 psi refueling pressure.

19. Make sure LEFT and RIGHT FUEL CONTENTS (green) lights are on when refueling pressure is applied.

**WARNING**

To prevent injury to personnel and damage to equipment, stop refueling immediately if TANK OVER PRESS (red) warning light comes on.

20. Fuel can be stopped from entering the external tanks by setting EXT TANK LOCKOUT switch to LOCKOUT position.
21. Monitor external fuel control panel assembly. If the tanks become overpressurized during refueling, the TANK OVER PRESS warning light will come on. If this occurs, stop refueling immediately and investigate cause.
22. After 60 to 120 gallons of fuel have entered tanks, make sure air is venting from vent mast on lower right side of fuselage, below the right front nozzle.
23. When tanks are full, LEFT and RIGHT FUEL CONTENTS lights will go off. If fuel flow does not stop automatically, fuel spillage from vent mast will result. Do substeps below immediately:
  - a. Stop fuel service operation and turn off fuel servicing equipment.
  - b. Disconnect refueling nozzle from refuel/defuel receptacle.

TO 00-25-172CL-3

- c. Alert fire department and take action to make area safe before moving aircraft or ground support equipment.
24. Stop refueling equipment.
25. Verify that the correct quantity of fuel is displayed on fuel digital display indicator.
26. Set LEFT and RIGHT REFUEL switches to flight position (toggles up).
27. Turn refueling nozzle counterclockwise and remove refueling nozzle. To prevent loss or damage to receptacle cap, make sure cap has engaged all three lugs on the refuel/defuel receptacle. On caps equipped with locking lever, make sure lever is flush with cap.
28. Inspect refueling receptacle for leakage and install receptacle cap.
29. Remove intercom cord and refueling unit bond wire.
30. Close Door 22.



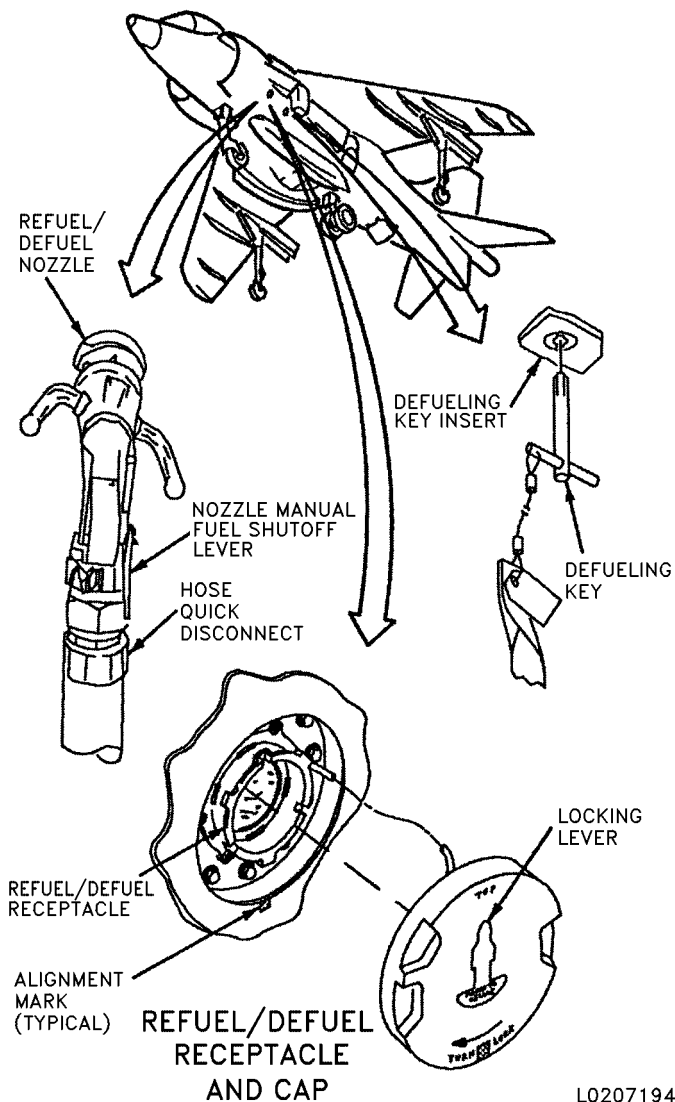

L0207194

Figure 7-1. Refueling/Defueling Controls and Indicators  
(sheet 1 of 3)

TO 00-25-172CL-3

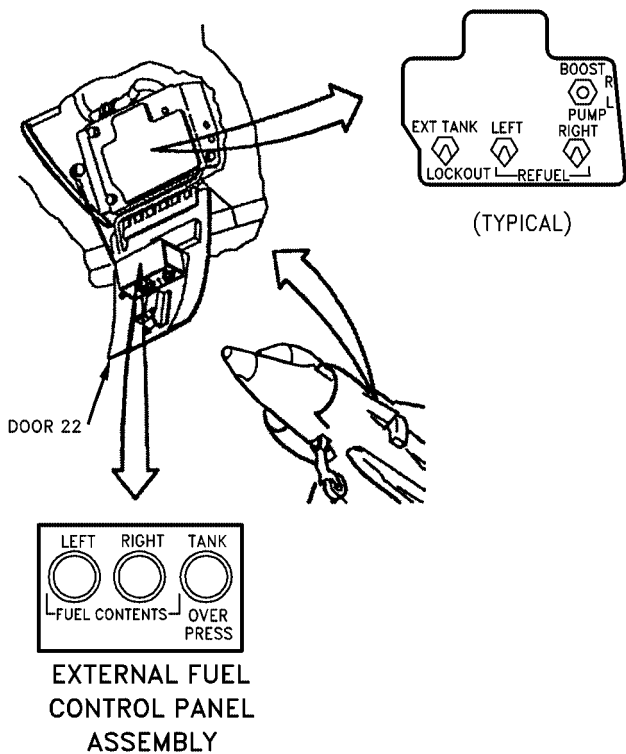

L0207195

Figure 7-1. Refueling/Defueling Controls and Indicators (sheet 2)

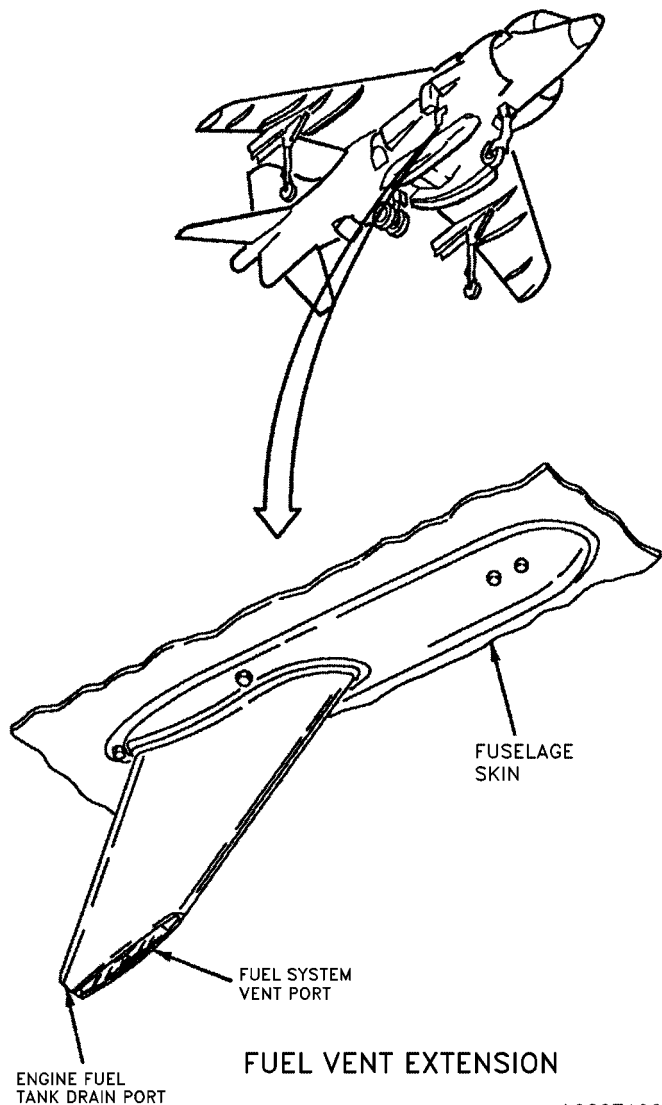

L0207196

Figure 7-1. Refueling/Defueling Controls and Indicators (sheet 3)

TO 00-25-172CL-3

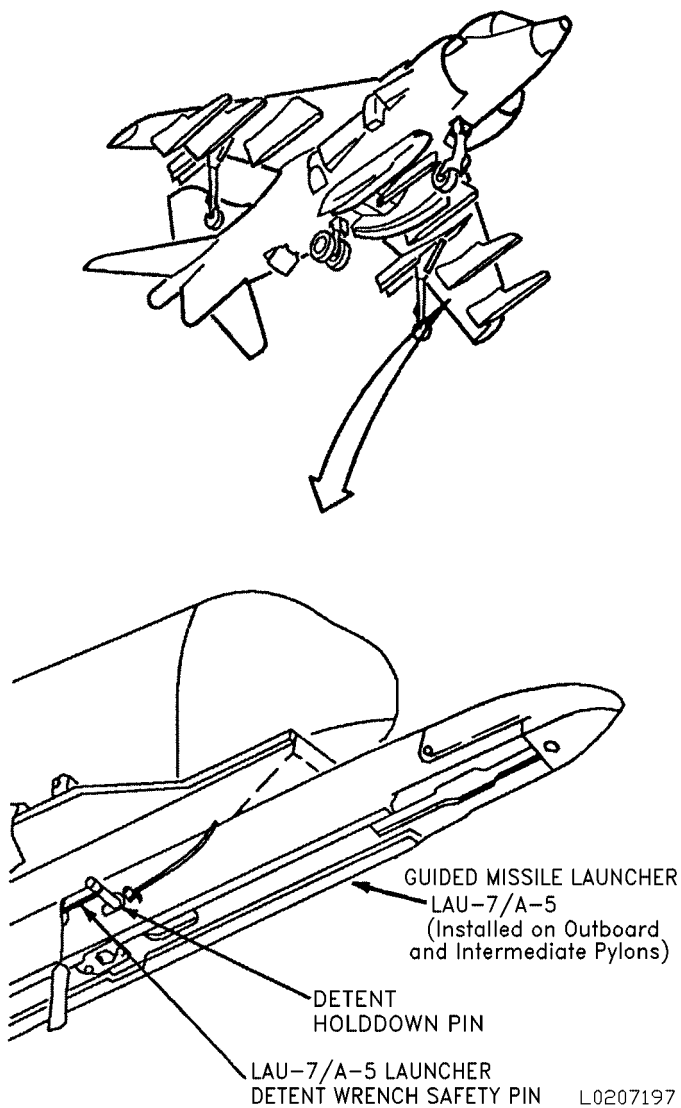
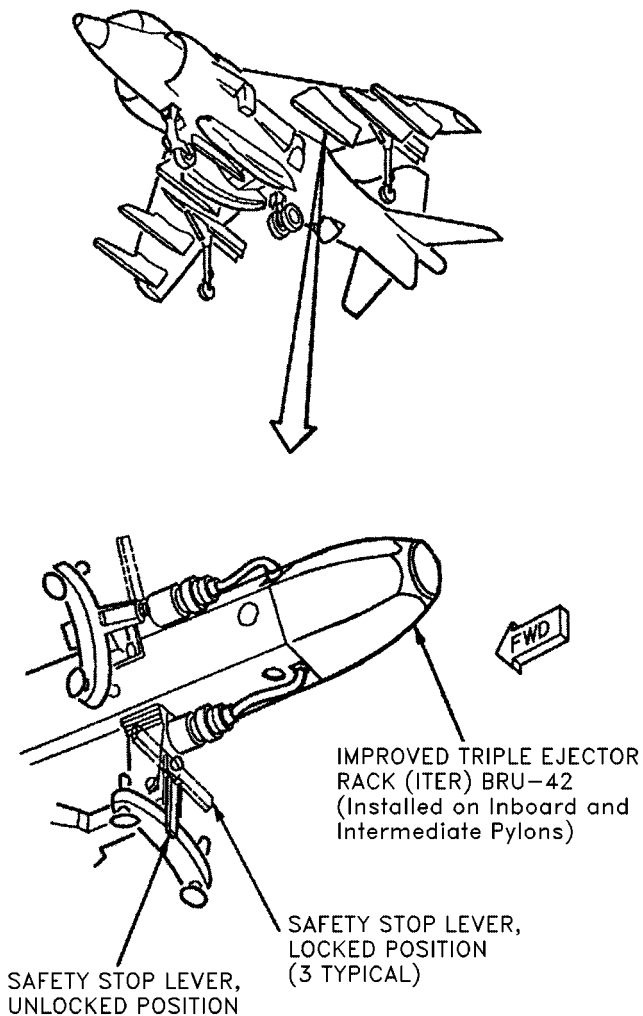

Figure 7-2. LAU-7/A-5 Launcher Detent Wrench Safety Pin



L0207198

Figure 7-3. ITER Ejector Unit Assembly Safety Stop Lever

TO 00-25-172CL-3

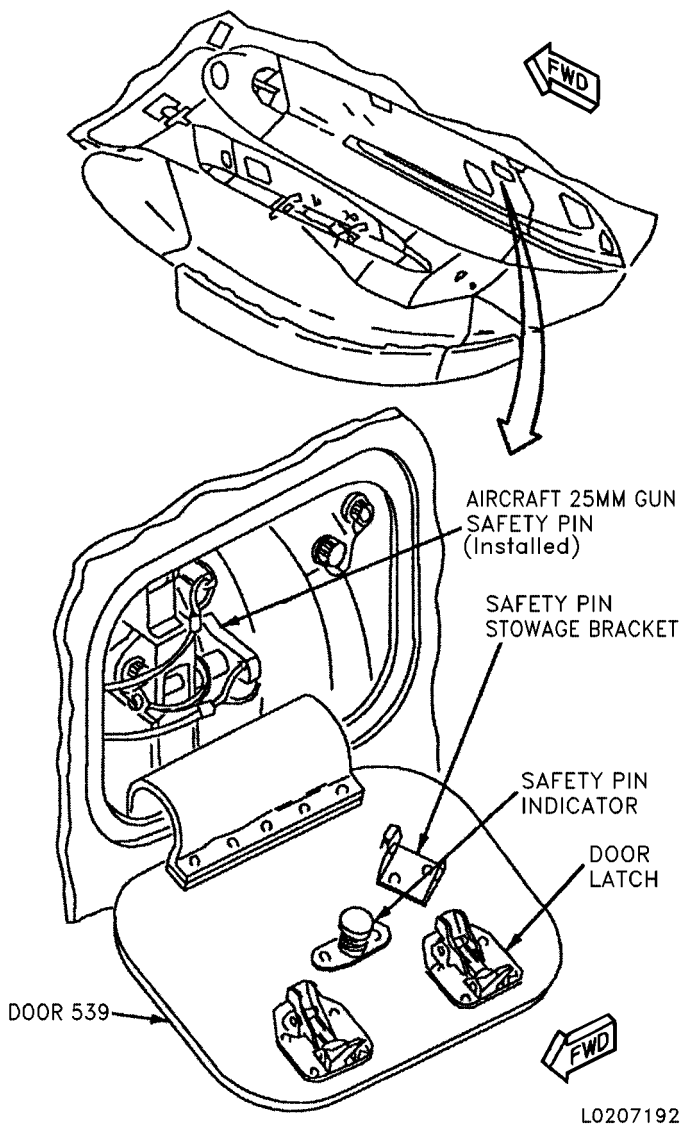

Figure 7-4. Aircraft 25MM Gun Safety Pin



L0207193

Figure 7-5. ALE-39 Ejector Rack Safety Pin

