

UNCLASSIFIED

AD NUMBER
AD856021
NEW LIMITATION CHANGE
TO Approved for public release, distribution unlimited
FROM Distribution authorized to U.S. Gov't. agencies and their contractors; Administrative/Operational Use; FEB 1969. Other requests shall be referred to Rome Air Developmental Center, Griffiss AFB, NY.
AUTHORITY
USAF ltr, 27 Aug 1973

AD856021

RADC-TR-68-403  
Final Technical Report  
February 1959



RELIABILITY PREDICTION - MECHANICAL  
STRESS/STRENGTH INTERFERENCE (NONFERROUS)

Charles Lipson  
Narendra J. Sheth  
Ralph L. Disney  
Mehmet Altun  
University of Michigan

This document is subject to special export controls and each transmittal to foreign governments, foreign nationals or representatives thereto may be made only with prior approval of RADC (EMERR), GAFB, NY 13440.

This Document Contains  
Missing Page/s That Are  
Unavailable In The  
Original Document

DDC  
RECEIVED  
AUG 6 1969  
RECEIVED  
B

Rome Air Development Center  
Air Force Systems Command  
Griffiss Air Force Base, New York

462

When US Government drawings, specifications, or other data are used for any purpose other than a definitely related government procurement operation, the government thereby incurs no responsibility nor any obligation whatsoever; and the fact that the government may have formulated, furnished, or in any way supplied the said drawings, specifications, or other data is not to be regarded, by implication or otherwise, as in any manner licensing the holder or any other person or corporation, or conveying any rights or permission to manufacture, use, or sell any patented invention that may in any way be related thereto.

ACQUISITION for		
CFSTI	WHITE SECTION	<input type="checkbox"/>
DDC	BUFF SECTION	<input checked="" type="checkbox"/>
UNCLASSIFIED		<input type="checkbox"/>
OR		
ACQUISITION AVAILABILITY CODES		
DIST.	AVAIL.	and/or SPECIAL
<i>21</i>		

Do not return this copy. Retain or destroy.

RELIABILITY PREDICTION - MECHANICAL  
STRESS/STRENGTH INTERFERENCE (NONFERROUS)

Charles Lipson  
Narendra J. Sheth  
Ralph L. Disney  
Mehmet Altun  
University of Michigan

This document is subject to special export controls and each transmittal to foreign governments, foreign nationals, or representatives thereto may be made only with prior approval of RADC (EMERR), GAFB, NY 13440.

FOREWORD

This report is the result of a study performed by the University of Michigan, Department of Mechanical Engineering, Ann Arbor, Michigan, from March 1967 to August 1968. The research team was headed by Professor Charles Lipson, actively assisted by Mr. Narendra J. Sheth, Associate Research Engineer. Mr. Sheth was instrumental in developing the techniques and methods required for the project and headed the group responsible for the data collection and the development of the computer approach used in the data analysis. Mr. Mehmet Altun contributed significantly toward the development of the computer approach and the data analysis. Professor Ralph L. Disney of the Department of Industrial Engineering developed and evaluated the analytical expressions of the interference.

The following contributed to the various phases of the project: Messrs. Raymond B. Pittman, John P. Godwin and Edward J. Gainer.

The study was performed for the Rome Air Development Center under contract F30602-67-C-0204, Project 5519, Task 551902. The RADC project engineer was Mr. Donald W. Fulton (EMERR).

The distribution of this document is limited under the U. S. Mutual Security Act of 1949.

This report has been reviewed and is approved.

Approved:   
DONALD W. FULTON  
Reliability Engineering Section  
Reliability Branch

Approved:   
WILLIAM BETKE  
Chief, Engineering Division

FOR THE COMMANDER

  
IRVING J. GABELMAN  
Chief, Advanced Studies Group

## ABSTRACT

This study addressed itself to the development of a Stress/Strength Interference Theory in form of a practical engineering tool, to be used for designing and quantitatively predicting the reliability of mechanical parts and components subjected to mechanical loading.

In our past investigation ("Reliability Prediction-Mechanical Stress/Strength Interference Theory" by Charles Lipson, Narendra J. Sheth and Ralph L. Disney; Final Report RADC-TR-66-710, March 1967, referred to in the present report as Reference 1) the Interference Theory was developed for the ferrous materials. In the present study, the work was extended to non-ferrous materials.

Early practices in stress-strength relationship dealt almost entirely along the lines of factors of safety. Utilization of such factors is justified when they are based on considerable experience with parts not too different from the one under consideration. However, when substantial changes in the geometry, the processing, or the function of the part are contemplated, a major error may result if the old factors of safety are projected to the new set of conditions.

In the present investigation, an approach was used which attempted to recognize the above limitations. Instead of an indiscriminate grouping of all the variables affecting stress and strength (generally fatigue strength) into one index (factor of safety) these variables were individually recognized. The principal variable is the scatter in the stresses imposed on the part and in the strength of the material resisting these stresses.

The prevailing practice is to use the mean values of the calculated stress and strength, ignoring the natural scatter that each may possess. However, the variability in these two factors results in a statistical distribution of stress and strength. When these two distributions interfere, that is when stress becomes higher than strength, failure results. Means of expressing these distributions, in a practical engineering sense, and means of calculating the resulting interferences, represent the heart of the present study.

In our past investigation<sup>(1)</sup> on ferrous materials, the problem of determining the scatter in the fatigue strength and, subsequently, its distribution function was resolved by a graphical method. Among the several distribution functions that were considered, only the Weibull distribution was used because of its wide use and the difficulty of handling other distributions by a graphical method.

In the present investigation on the non-ferrous materials, a computer approach was developed which made the determination of the distribution functions of fatigue strength considerably less difficult (Section 6). Consequently, several distributions were tried: Weibull, Largest Extreme Value, Smallest Extreme Value, Logistic and Normal. The reasons for the selection of these particular distributions are given in Section 6.3. It was later found that the Logistic distribution had similar characteristics to the Normal

distribution and therefore it was not followed any further.

Mechanical Properties Data Center in Traverse City, Michigan, was found to be a very useful source of information for the fatigue strength data for various non-ferrous materials under various conditions such as the type of loading, surface finish, stress concentration, heat treatment, temperature, environment, etc. Considerable fatigue data thus obtained were then organized and systematized according to materials and conditions.

A computer program was developed so that when these data (raw S-N data) were fed into the program, the computer printed out the degree of fit and the parameters for all the distribution functions tried for any given set of fatigue strength data.

In the first part of this program, the scatter in life was converted into the scatter in strength. In the second part, the distribution functions (Weibull, Normal, Logistic, LEV and SEV) were fitted to these strength data. The best fitting distributions (those with the highest degree of fit) and their parameters were then chosen, and these are presented in a tabular form in Appendix 1 for various non-ferrous materials and under various conditions.

In order to present these data in a pictorial, and thus more easily digestible form, the representative parameters were then plotted on log-log scale against life for various materials and conditions (Section 6.7). In order to put this information on the same consistent basis, all the data were expressed in terms of the same distribution (Normal). The plots were made by expressing the mean ( $\mu$ ) and standard deviation ( $\sigma$ ) as a function of life (Section 6.7). The reasons for the selection of the Normal distribution for these graphs, the description of the computer approach, and the statistical tools used in developing this approach are given in Section 6.

The problem of stress distribution (Section 7) was investigated in more detail than in the previous study<sup>(1)</sup>, but no additional information was located. When one speaks of "stress distribution" he usually refers to a spectrum of loading or stresses to which a part is subjected. Indeed, most of the available data on the subject is expressed in this manner. In an engineering sense, this kind of a distribution means the number of times that a given part is subjected to a given load or stress. In the Interference Theory however, this is not what is wanted. For consistency with the strength distribution, the number of parts subjected to a given stress is required instead.

In the present investigation, the required stress distribution was obtained in the same manner as is our past study. This was done by converting the stress spectrum, which generally has some mean stress, into a spectrum with zero mean, with the aid of the Goodman diagram. This facilitated the conversion of the resultant spectrum into an equivalent stress based on zero mean stress. The conversion was accomplished by means of Miner's rule. The required stress distribution was then expressed in terms of the equivalent stress. This distribution was then compared with the strength distribution to determine the probability of interference.

Most investigators in the past have assumed both the stress and strength distributions to be normal. In those cases when they were not normal, a Monte-Carlo technique was employed. This involved a sophisticated means of randomly selecting a sample from one distribution and comparing it with a sample from a different distribution.

In view of the serious limitations of the Monte-Carlo technique, a method of Integrals was developed (Appendix 3) and used in the present study. This method involved developing an integral resulting from the interference of two distributions and evaluating this complex integral. Numerical analysis was carried out (Appendix 3) using an IBM 360 computer to solve these integrals.

In our past investigation on ferrous materials<sup>(1)</sup>, these integrals and hence the interference values were evaluated and tabulated for the following combinations:

<u>Stress Distribution</u>	<u>Strength Distribution</u>
Normal	Normal
Weibull	Weibull
Normal	Weibull

In the present investigation on non-ferrous materials, data analysis (Section 6) revealed many cases where fatigue strength followed distributions other than Weibull or Normal. Hence, it was necessary to develop tables of interference values for the following additional combinations:

<u>Stress Distribution</u>	<u>Strength Distribution</u>
Normal	Weibull (Extended-see Section 4.2)
Normal	Largest Extreme Value
Normal	Smallest Extreme Value

These interference values (tabulated in Appendix 2) were found to be highly non-linear. Therefore, for the purpose of interpolating these values in a given table or between the tables, it is recommended that a higher order interpolation than linear be used. A suggested method of interpolation, with some solved examples illustrating this method, is given in Section A-2.1.

In order to show the application of The Interference Theory Technique developed in the present study two examples were solved, as described in Section 9.



## TABLE OF CONTENTS

Section	Page No.
1. Introduction	1
2. Interference Theory	5
2.1 Two Normal Distributions	5
2.2 Consistency of Two Distributions	8
2.3 Non-Normal Distributions	10
2.4 The Integral Method	10
3. Objectives of the Present Study	11
4. Study Approach	12
4.1 Literature Search	12
4.2 Theoretical Analysis	12
4.3 Empirical Data	13
4.4 Factors Affecting the Statistical Distribution of Fatigue Strength	14
4.5 Computer Analysis of Strength Data	16
5. Analytical Expressions for Interference	17
5.1 Introduction	17
5.1.1 Interference Probabilities	17
5.1.2 Calculation of Probabilities of Failure	18
5.1.3 Interference Tables, Appendix 2	22
5.2 Use of Interference Tables in Appendix 2	23
5.2.1 Parameters for the Weibull Distributed Strength, Normal Distributed Stress	23
5.2.2 Parameters for the Smallest Extreme Value Distributed Strength, Normal Distributed Stress	23
5.2.3 Parameters for the Largest Extreme Value Distributed Strength, Normal Distributed Stress	24
5.2.4 Use of the Tables, Explanation of Missing Values and Interpolation	24
6. Statistical Distribution of Fatigue Strength by Computer Approach	26
6.1 Least Squares Method of Fitting a Line to S-N Type Data	26
6.1.1 Method of Least Squares	26
6.1.2 Application of Least Squares Method to S-N Data	28
6.1.3 Correlation Coefficient	29
6.2 Conversion of Life Data to Strength Data	31
6.2.1 Computation of Parallel S-N Lines	31
6.2.2 Computation of the Scatter of Strength at a Given life	33
6.3 Distribution Functions	33
6.3.1 Weibull Distribution	34
6.3.2 Normal Distribution	34
6.3.3 Extreme Value Distributions	35

6.4	The Linearizing Transformation Equations of the Distribution Functions	38
6.4.1	Weibull Distribution	40
6.4.2	Normal Distribution	40
6.4.3	Extreme Value Distributions	42
6.5	Fitting the Linearized Distribution to the Strength Data	45
6.5.1	Weibull Distribution	45
6.5.2	Normal Distribution	48
6.5.3	Extreme Value Distributions	50
6.6	Determination of the Best Fitting Distribution and Its Parameters	51
6.6.1	Weibull Distribution	52
6.6.2	Normal Distribution	52
6.6.3	Extreme Value Distributions	53
6.7	Graphs of the Fatigue Strength Distribution Parameters	53
6.7.1	Expression of Data in Terms of Normal Parameters	53
6.7.2	Explanation of the Graphs	57
6.7.3	Use of Graphs	60
6.7.4	Graphs	61
7.	The Statistical Distribution of Stress	118
7.1	Stress Spectrum vs. Stress Distribution	118
7.2	Conversion of a Stress Spectrum to an Equivalent Stress (Sequ)	118
7.2.1	Miner's Rule	120
7.2.2	Corten-Dolan's Rule	124
8.	The Interference of a Stress Distribution with a Strength Distribution	128
9.	Application of Interference Theory to Design Problems	133
9.1	Example Problem No. 1 (Effect of Stress Concentration on Reliability)	133
9.2	Example Problem No. 2 (Effect of Temperature on Reliability)	143
	Conclusions and Recommendations	147
	References	149
	Bibliography	151
Appendix 1	Tables of the Distribution Parameters of Fatigue Strength	155
A-1.1	Index to Distribution Parameters for Various Non-Ferrous Materials	156
A-1.2	Distribution Functions and Their Parameters Used in Tables	161
A-1.3	List of Abbreviations and Symbols Used in Tables	165
A-1.4	Composition of the Non-Ferrous Materials	166
A-1.5	Tables	173

A-1.5.1	Aluminum Alloys	174
A-1.5.2	Cobalt Alloys	236
A-1.5.3	Copper Alloys	243
A-1.5.4	Magnesium Alloys	250
A-1.5.5	Nickel Alloys	257
A-1.5.6	Titanium Alloys	283
A-1.5.7	Other Non-Ferrous Alloys	346
Appendix 2	Tables of Interference Values	351
A-2.1	A Method for Interpolating the Interference Values	352
A-2.1.1	Higher Order Interpolation Procedure	353
A-2.1.2	Example Problem for One-Way Interpolation	355
A-2.1.3	Example Problem for Two-Way and Three-Way Interpolation	358
A-2.2	Stress Distribution - Normal, Strength Distribution - Weibull	368
A-2.2.1	Stress Standard Deviation = 0	369
A-2.2.2	Stress Standard Deviation $\neq$ 0	373
A-2.3	Stress Distribution - Normal, Strength Distribution - Normal	400
A-2.3.1	Stress Standard Deviation = 0	401
A-2.3.2	Stress Standard Deviation $\neq$ 0	403
A-2.4	Stress Distribution - Normal, Strength Distribution - Largest Extreme Value	405
A-2.4.1	Stress Standard Deviation = 0	406
A-2.4.2	Stress Standard Deviation $\neq$ 0	409
A-2.5	Stress Distribution - Normal, Strength Distribution - Smallest Extreme Value	416
A-2.5.1	Stress Standard Deviation = 0	417
A-2.5.2	Stress Standard Deviation $\neq$ 0	420
Appendix 3	Evaluation of the Integrals by Numerical Analysis	427
A-3.1	The Problem	428
A-3.2	Simplification of the Equations	429
A-3.3	Numerical Methods Considered for the Problem	430
A-3.4	Simplifying Approximations	434
A-3.5	Limits of Integration	435
A-3.5.1	Limits for Normal - Smallest Extreme Value Case	435
A-3.5.2	Limits for Normal - Largest Extreme Value Case	435
A-3.6	Determination of Simpson's Rule Step-Size	436
A-3.7	Error Analysis	438
A-3.8	Summary	439
Appendix 4	Flow Chart of the Computer Program Used for Determination of the Fatigue Strength Distribution	440
A-4.1	Explanation of the Symbols Used in the Flow Chart	441
A-4.2	Explanation of the Flow Chart	443

A-4.2.1	Part One - Conversion of Life Data to Strength Data and Non-Linear Mode Variables to Linear Mode Variables	443
A-4.2.2	Part Two - Determination of the Best Fitting Distribution	444
A-4.2.3	Part Three - External function Fit	445
A-4.3	The Flow Chart	446
A-4.3.1	Part One	447
A-4.3.2	Part Two	448
A-4.3.3	External Function Fit	450

## EVALUATION

1. This study was concerned with the development of a practical engineering tool to be used in predicting the reliability of mechanical parts fabricated of nonferrous metals and subjected to dynamic loading. The tool was to be compatible with the Stress-Strength Interference Theory as reported in RADC-TR-66-710 and be usable by design engineers with limited statistical background.
2. The study has provided a prediction technique which is almost "cook-book" in nature and requires a minimum amount of computation except as required in the interpolation of the tabulated interference values. The tabular values are highly nonlinear; thus, linear interpolation cannot be used. Procedures for higher order interpolation are given and illustrated. Within the limitation that the material must be a nonferrous metal, the reliability of any part subjected to fatigue loading can be predicted. Examples of such parts would include springs, fasteners, shafts, beams, torsion bars, vehicle frames and suspensions, forgings and castings. The accuracy of the technique depends on the knowledge the user has of the stress distribution, i.e., measured or estimated.
3. The results of this study and of the earlier study of ferrous metals will be combined and presented in the RADC Nonelectronic Reliability Notebook.

  
DONALD W. FULTON  
Reliability Engineering Section  
Reliability Branch

## SECTION 1 INTRODUCTION

A complete cycle of reliability is made up of four stages; 1. Specification of Reliability; 2. Prediction of Reliability; 3. Verification of Reliability; 4. Preservation of Reliability. The heart of the second stage, namely, the Prediction of Reliability, is the Interference Theory.

The basic idea behind reliability is that a given part has certain physical properties which, if exceeded, will result in failure. The factor which may cause these properties to be exceeded is the stress imposed by the operating conditions. Thus, in prediction of reliability it is not the stress alone or the strength alone that is the determining factor but the combined effect of the two.

Early practices in stress-strength relationships dealt almost entirely along the lines of factors of safety. Once a part was designed and the ratio of strength to stress was in the range of approximately 5 to 10, it was considered to be safe for service. In certain industries and in certain applications, factors of safety as high as 20:1 were employed.

The definition of the factors of safety varied from user to user, depending on the sophistication and the complexity of the problem.

Some of these definitions, found in literature, are listed below:

$$\text{Factor of Safety} = \frac{\text{Ultimate Strength}}{\text{Nominal Stress}}$$

$$\text{Factor of Safety} = \frac{\text{Yield Strength}}{\text{Nominal Stress}}$$

$$\text{Factor of Safety} = \frac{\text{Ultimate Strength}}{\text{Actual Working Stress}}$$

$$\text{Factor of Safety} = \frac{\text{Yield Strength}}{\text{Actual Working Stress}}$$

$$\text{Factor of Safety} = \frac{\text{Maximum Safe Load}}{\text{Normal Load}}$$

$$\text{Factor of Safety} = \frac{\text{Computed Strength}}{\text{Computed Load}}$$

$$\text{Margin of Safety} = \frac{\text{Strength-Stress}}{\text{Stress}}$$

$$\text{Design Factor} = \frac{\text{Strength}}{\text{Design Stress}}$$

$$\text{Factor of Utilization} = \frac{\text{Stress}}{\text{Strength}}$$

$$\text{Functional Reserve Factor} = \frac{\text{Magnitude of Variable Producing Failure}}{\text{Magnitude of Variable at Operating Conditions}}$$

where the variable could be force, power, torque, material, surface finish, fillet radius, etc.

Apparently the factor of safety was meant to account for all the variables which were known to affect the stress and strength of the member. The utilization of a factor of safety of this kind has justification only when its value is based on considerable experience, with parts not too different from the one under consideration. However, when substantial changes in the geometry, the processing, or the function of the part are contemplated, a major error may result if the old factor of safety is projected to the new set of conditions.

This can be illustrated by the problem of automotive axle shafts which were failing in service in large numbers. These shafts had been fabricated from a steel with a tensile strength of 240,000 psi, and yet, the operating stresses as measured in actual service were found to be only 13,000 psi. This produced an apparent factor of safety of  $240,000/13,000 = 18.5$ . This is obviously a fictitious value, since the shafts were failing in service, and the true factor of safety was less than one. The explanation lies in the fact that axle strength to be compared with the 13,000 psi operating stress should not have been the ultimate strength of the material (240,000 psi) but the fatigue strength corresponding to the surface finish of the shafts, the mode of loading to which the shaft was subjected, etc. When the ultimate strength was reduced by these derating factors, the resultant value was found to be 12,000 psi. This strength, when compared with the 13,000 psi stress, produced the realistic factor of safety of 0.9.

Examples such as this lead to the next phase in the relationship between stress and strength, namely, to the concepts of a significant stress and a significant strength. By significant stress is meant the actual stress imposed on the part, and it may include the effect of stress raisers, magnification due to impact loading, residual stresses, etc. By significant strength (generally, fatigue strength) is meant the actual strength of the part in its fabricated form under actual operating conditions. A rational approach to significant strength still employs ultimate strength as the basis. However, instead of an indiscriminate grouping of all the factors affecting the ultimate strength into one index, it attempts to evaluate quantitatively the effect of each individual factor pertaining to the part and the conditions under consideration. The result is a value which is strictly applicable to the part under consideration and to the set of loading conditions to which the part is subjected in service. The principal factors affecting strength and which must be considered in determining the significant strength are: life expectancy, type of loading (axial, bending, torsional, or a combination), size effect, surface finish, surface treatment, notch effects, mode of loading (static, completely reversed dynamic, or a combination).

These concepts of significant stress and significant strength represent a major step toward a more realistic prediction of reliability and, as such, they have been included in the present investigation. By themselves, however, they are not sufficient. This is because the prevailing practice is to use the mean values of the calculated strength and stress, ignoring the natural scatter that stresses and strengths may have.

The variability in these two factors results in the existence of a statistical distribution function of stress and strength (See Figure 2.1) and is the heart of the Interference Theory. Thus, for proper prediction of reliability, an estimate must be made of both the mean value and the dispersion characteristics of both the strength and stress.

The strength of the part, as all properties of non-homogeneous materials, varies from specimen to specimen, in view of the variation in hardness, surface finish, degree of stress concentration, etc. In our past investigation ("Reliability Prediction - Mechanical Stress/Strength Interference" by Charles Lipson, Narendra J. Sheth, and Ralph L. Disney, Final Report RADC-TR-66-710, March 1967, referred to in the present report as Reference 1) the problem of determining the variation in strength and subsequently its distribution function was resolved by a graphical method. Among the several possible distribution functions considered, only the Weibull distribution was used because of its wide use and the difficulty of handling other distributions by a graphical method. In the present investigation a computer approach was developed by which the determination of the distribution functions of strength became considerably less difficult. (This is discussed in Section 6.) Consequently, several distribution functions were tried. These were: Weibull, Largest Extreme Value, Smallest Extreme Value, Logistic and Normal. The reasons for selection of these particular distributions are given in Section 6.3. It was later found that the Logistic Distribution had somewhat the same characteristics as the Normal Distribution and, therefore it was not followed any further. The computer printed the degree of fit and the parameters for all of the above distributions for a given set of strength data. The best fitting distributions and their parameters were then chosen, and they are presented in a tabular form in Appendix 1 for various materials and conditions studied. The representative ones were then plotted in order to determine the effect of various conditions on the strength of various materials. In order to put the information on the same consistent basis, all the data were expressed in terms of the same distribution (Normal) and the plots were made by expressing the means ( $\mu$ ) and standard deviations ( $\sigma$ ) as a function of life (See Section 6). The reasons for the selection of the Normal Distribution for these graphs are given in Section 6.

As is the case of strength, the operating stresses vary too. These stresses vary from time to time in a particular part, from part to part in a particular design, and from environment to environment. Therefore, both the mean value and the dispersion characteristics of stress and strength must be determined.

Once the parameters of the strength and stress distributions are found, percent interference and thus probability of failure can be determined



from the interference area (shaded area in Figure 2.1). Means of computing these interferences represent one of the principal objectives of the present investigation.

## SECTION 2 INTERFERENCE THEORY

Suppose there are two barrels containing slips of paper, each having a number printed on it. The numbers in barrel Y are distributed according to distribution Y, as in Figure 2.1, and the numbers in barrel X are distributed according to distribution X. If, at random, slips of paper from each barrel are selected and paired, they may be classified into successes and failures. A success is constituted by a strength value exceeding a stress value, as for example, when  $x_1 > y_1$ . Failure will occur if  $x_2 < y_2$  as shown. It will be noted that, although the shaded area is a measure of interference, it is not interference itself: a pair of points  $x_3$  and  $y_3$ , although in the shaded area, will not produce failure. By continued pairing of stresses and strengths at random, pairs will be found where the stress will exceed the strength. By continued experimentation a good estimate of the probability of interference can be found.

## 2.1 TWO NORMAL DISTRIBUTIONS

From an exhaustive survey of literature made during the past investigation(1)\*, it was found that most studies have assumed both the stress and the strength distributions to be normal. This is a natural assumption to make in order to solve a practical problem, as no work was found dealing with an analytical expression for the interference of two non-normal distributions.

When the stress and strength distributions are assumed to be normal, the probability of interference can be determined from the equation(2):

$$z = \frac{|\mu_y - \mu_x|}{\sqrt{\sigma_x^2 + \sigma_y^2}} \quad (2.1)$$

where  $\mu_y$  = mean stress

$\mu_x$  = mean strength

$\sigma_x^2$  = strength variance

$\sigma_y^2$  = stress variance

$z$  = standardized normal variate determined from standard tables (See Table 2.1)

Thus, if the average stress is 30 ksi with a standard deviation of 3 ksi and the average strength is 50 ksi with standard deviation of 10 ksi,  $z = 1.91$  and from Table 2.1  $\alpha$ , which represents interference, is found to be .0281. Thus, the percent interference (the probability of failure) is 2.81%.

\* Numbers in parenthesis designate References listed on Page 149.

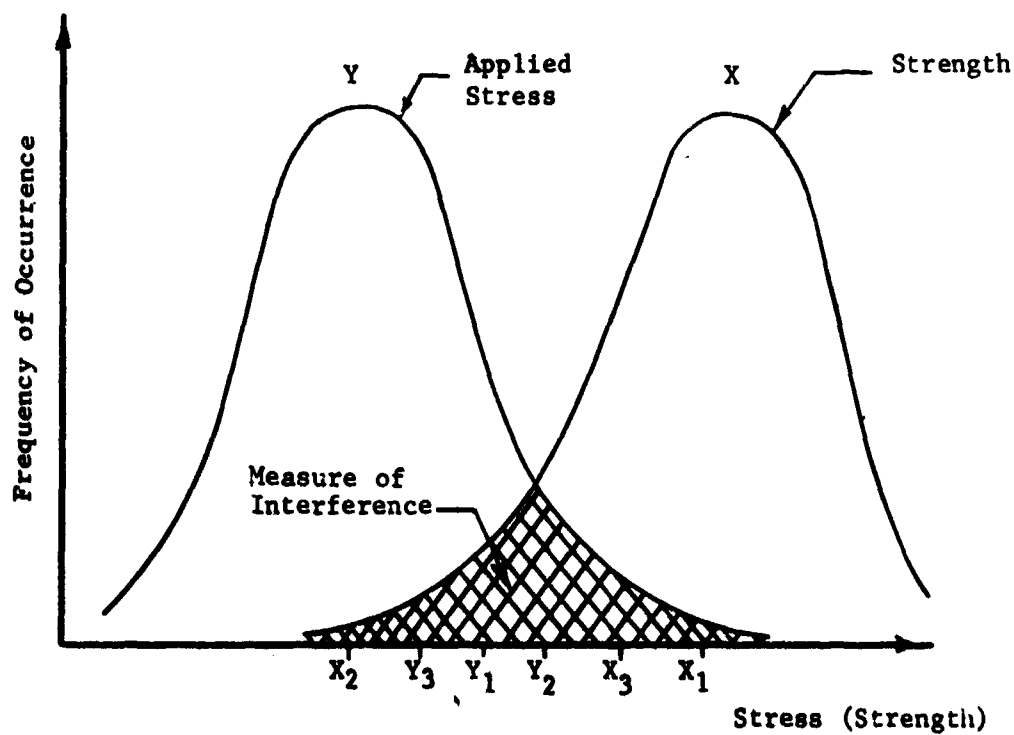

Figure 2.1 Interference of Stress and Strength Distributions

NORMAL DISTRIBUTION

Tabulation of the values of  $\alpha$  versus  $K_\alpha$  for the Standardized Normal Curve.

$$\alpha = P(z > K_\alpha) = \int_{K_\alpha}^{\infty} \frac{1}{\sqrt{2\pi}} e^{-\frac{z^2}{2}} dz$$

= Area under the Standardized Normal Curve from  $z = K_\alpha$  to  $z = \infty$

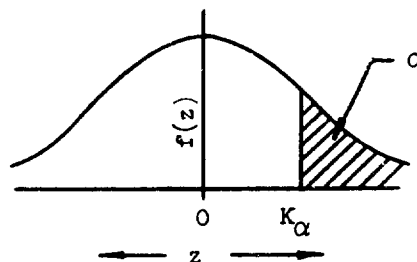

$K_\alpha$	.00	.01	.02	.03	.04	.05	.06	.07	.08	.09
0.0	.5000	.4960	.4920	.4880	.4840	.4801	.4761	.4721	.4681	.4641
0.1	.4602	.4562	.4522	.4483	.4443	.4404	.4364	.4325	.4286	.4247
0.2	.4207	.4168	.4129	.4090	.4052	.4013	.3974	.3936	.3897	.3859
0.3	.3821	.3783	.3745	.3707	.3669	.3632	.3594	.3557	.3520	.3483
0.4	.3446	.3409	.3372	.3336	.3300	.3264	.3228	.3192	.3156	.3121
0.5	.3085	.3050	.3015	.2981	.2946	.2912	.2877	.2843	.2810	.2776
0.6	.2743	.2709	.2676	.2643	.2611	.2578	.2546	.2514	.2483	.2451
0.7	.2420	.2389	.2358	.2327	.2296	.2266	.2236	.2206	.2177	.2148
0.8	.2119	.2090	.2061	.2033	.2005	.1977	.1949	.1922	.1894	.1867
0.9	.1841	.1814	.1788	.1762	.1736	.1711	.1685	.1660	.1635	.1611
1.0	.1587	.1562	.1539	.1515	.1492	.1469	.1446	.1423	.1401	.1379
1.1	.1357	.1335	.1314	.1292	.1271	.1251	.1230	.1210	.1190	.1170
1.2	.1151	.1131	.1112	.1093	.1075	.1056	.1038	.1020	.1003	.0985
1.3	.0968	.0951	.0934	.0918	.0901	.0885	.0869	.0853	.0838	.0823
1.4	.0808	.0793	.0778	.0764	.0749	.0735	.0721	.0708	.0694	.0681
1.5	.0668	.0655	.0643	.0630	.0618	.0606	.0594	.0582	.0571	.0559
1.6	.0548	.0537	.0526	.0516	.0505	.0495	.0485	.0475	.0465	.0455
1.7	.0446	.0436	.0427	.0418	.0409	.0401	.0392	.0384	.0375	.0367
1.8	.0359	.0351	.0344	.0336	.0329	.0322	.0314	.0307	.0301	.0294
1.9	.0287	.0281	.0274	.0268	.0262	.0256	.0250	.0244	.0239	.0233
2.0	.0228	.0222	.0217	.0212	.0207	.0202	.0197	.0192	.0188	.0183
2.1	.0179	.0174	.0170	.0166	.0162	.0158	.0154	.0150	.0146	.0143
2.2	.0139	.0136	.0132	.0129	.0125	.0122	.0119	.0116	.0113	.0110
2.3	.0107	.0104	.0102	.0099	.0096	.0093	.0091	.0089	.0086	.0084
2.4	.0082	.0079	.0077	.0075	.0073	.0071	.0069	.0067	.0065	.0063
2.5	.0062	.0060	.0058	.0057	.0055	.0053	.0052	.0050	.0049	.0048
2.6	.0046	.0045	.0044	.0042	.0041	.0040	.0039	.0037	.0036	.0035
2.7	.0034	.0033	.0032	.0031	.0030	.0029	.0028	.0028	.0027	.0026
2.8	.0025	.0024	.0024	.0023	.0022	.0021	.0021	.0020	.0019	.0019
2.9	.0018	.0018	.0017	.0016	.0016	.0015	.0015	.0014	.0014	.0013

Table A1 Normal Distribution (1)

In practical applications of the Interference Theory the following problem arises: both distributions under consideration extend to plus and minus infinity. It is apparent, therefore, that any two distributions will overlap and cause interference. This, of course, is erroneous because some distributions, such as strength, must have a finite lower bound of zero. In many situations the physical set-up and the sample size adjust for this lower bound. For example, suppose a part is designed so that the mean of the strength distribution is placed  $6\sigma$  away from the mean of the stress distribution, both distributions having standard deviation equal to  $\sigma$ . From Equation 2.1 it is found:

$$z = \frac{6\sigma}{\sqrt{2\sigma^2}} = 4.24$$

and the probability of interference comes out to be .00001. This means that only one part will fail in 100,000 parts produced. If actually only 50,000 parts are made, the physical problem has effectively truncated the distributions. However, the probability of failure of one part remains .00001. This means that, due to sample size, the extreme portions of these distributions are no longer important since the sample size is such that not even one failure can be expected.

For the ease of application of the Interference Theory for the case of two Normal distributions, a graph was constructed as shown in Figure 2.2. The example solved previously through Equation (2.1) now yields:

$$\frac{|\mu_1 - \mu_2|}{\sigma_{\min}} = \frac{50\text{ksi} - 30\text{ksi}}{3\text{ksi}} = 6.67 \text{ and,}$$

$$\frac{\sigma_{\max}}{\sigma_{\min}} = \frac{10\text{ksi}}{3\text{ksi}} = 3.3$$

and the percent interference (the probability of failure) comes out approximately 3% as before.

## 2.2 CONSISTENCY OF TWO DISTRIBUTIONS

In the application of the Interference Theory, the following important point must be considered: the distribution of stress and the distribution of strength must be consistent with each other. In a fatigue test or in actual application in service, a single part has a single fatigue life for a given loading condition. Subsequent testing of additional parts under the same load will show a scatter in life leading to a life distribution. Through more extensive testing a strength distribution for a given life can be obtained, such as the distribution in Figure 2.1 (the method of obtaining a strength distribution from a life distribution is described in Section 6).

It follows then that, for a consistent development, the stress distribution must be of the same nature as the strength distribution. That is, it should represent the plot of the frequency of occurrence of an applied stress versus the applied stress. This is not the same as the stress distribution conventionally derived from the spectrum of loading acting on the part. The con-

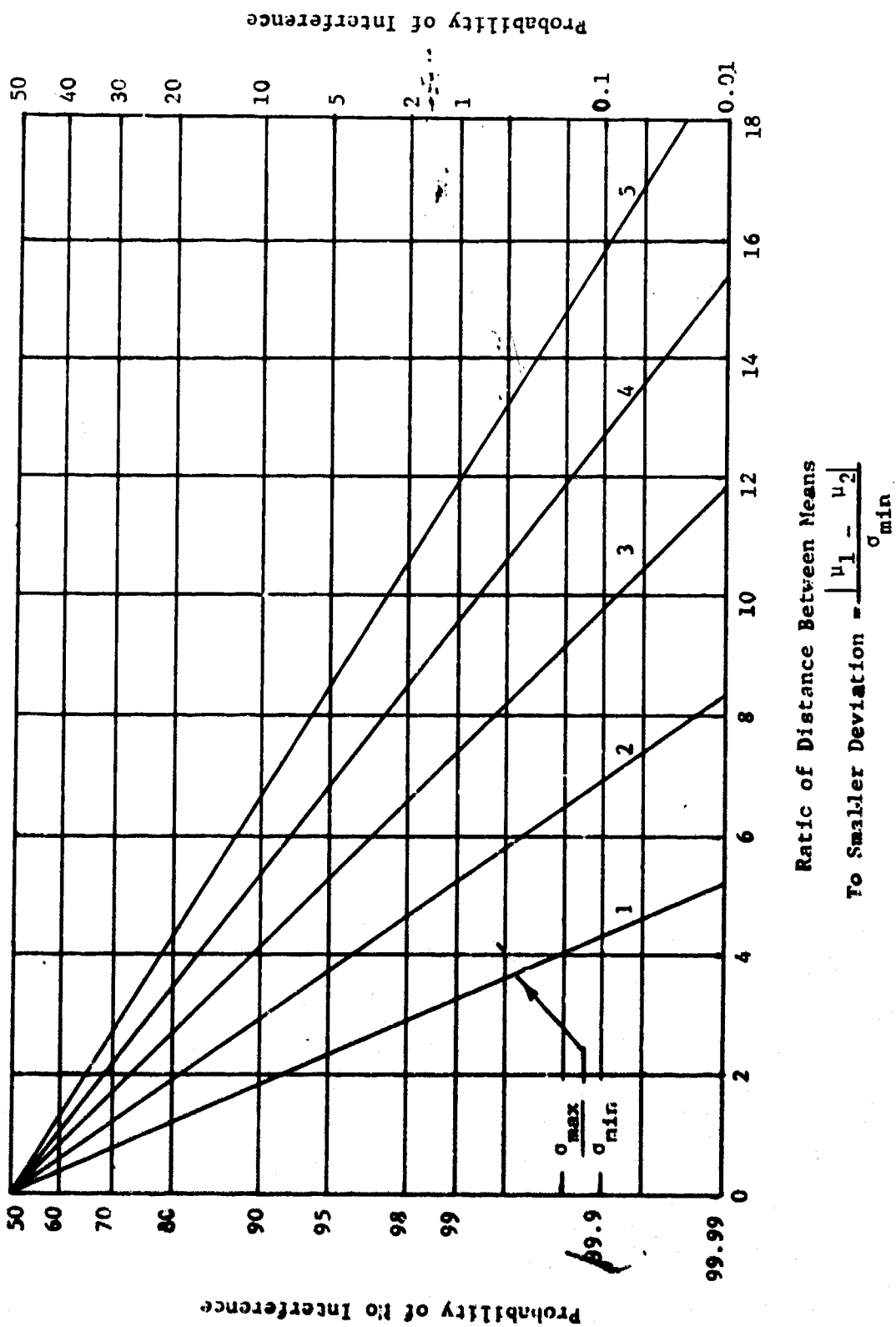

Figure 2.2 Probability of Interference of Two Normal Distributions. (3)

version of one to the other must be accomplished through the use of the equivalent stress ( $S_{eq}$ ) and Miner's or Corten-Dolan's Rules. This is the method used in the present investigation, as described in Section 7.

### 2.3 NON-NORMAL DISTRIBUTIONS

So far the discussion has been limited to the cases when both the stress and strength distributions can be assumed to be normal. In cases when either one or both are not normal the problem is much more involved. For example, the intersection of a Normal and a Weibull distribution produces a distribution of an unknown origin.

In the past, problems such as this were solved largely through "brute force," by a method commonly referred to as the Monte-Carlo Technique. Essentially, the Monte-Carlo Technique consists of a sophisticated means of randomly selecting a sample from one distribution and comparing it with a random sample taken from a different distribution. This is accomplished with the aid of Tables of Random Numbers. The resultant paired data are plotted as a Cumulative Distribution Function on Normal, Weibull, etc. probability papers and the percent interference is read from the graph.

### 2.4 THE INTEGRAL METHOD

In the present investigation a Method of Integrals was used in preference to the Monte-Carlo Technique. This method involves determining, as an integral, the expression for the interference of the two distributions under consideration and establishing percent interference from this integral.

The advantages of the Integral Method are:

1. For some distributions the integrals have been already tabulated and percent interference can be read directly from the table.
2. In those cases where the integrals have not been already tabulated, they can be evaluated by Numerical Analysis as done in the present investigation.
3. The major shortcoming of the Monte-Carlo Technique is that it requires a very large sample size for any accuracy. This shortcoming is avoided when the Method of Integrals is used.
4. One of the objectives of the present study is to develop and evaluate an analytical expression for interference of any two distributions. Such an expression is possible when the Method of Integrals is used but not when the Monte-Carlo Technique is employed.

## SECTION 3 OBJECTIVES OF THE PRESENT STUDY

The objectives of the study described in this report were:

1. To refine and to reduce to practice the Stress/Strength Interference Theory technique for designing and predicting the quantitative reliability of mechanical parts and components fabricated from various non-ferrous materials under mechanical loading. Maximum use was to be made of empirical, practical engineering values as well as a sound theory.
2. To study the effect of such factors as type of loading, surface finish, temperature, heat treatment, stress concentration, surface treatment, manufacturing processes, environment, etc. on the statistical distribution of fatigue strength.
3. To determine, from the existing available empirical data, the distribution of the fatigue strength under the effect of each of the above factors.
4. To develop a computer approach [as contrasted with the graphical approach of our past investigation(1)] for determining the statistical distribution function of fatigue strength at a given life. This method has the advantage of high accuracy and time saving.
5. To develop the means of synthesizing the strength distribution function when such function is non-time variant, i.e. infinite life design, and when such function is time variant, i.e. finite life design.
6. To develop an analytical expression of the distribution of interference for the general case where the two interfering distributions are different. In the present investigation the distributions studied were:

<u>Stress</u>	<u>Strength</u>
Normal	Weibull
Normal	Largest Extreme Value
Normal	Smallest Extreme Value



## SECTION 4 STUDY APPROACH

## 4.1 LITERATURE SEARCH

In the past investigation on ferrous materials<sup>(1)</sup>, an exhaustive literature search was made to determine the State of the Art in the field of Reliability Prediction - Mechanical Stress/Strength Interference. Specific topics covered were: Interference Theory, Mathematical Tools as related to the Interference Theory, Monte-Carlo Technique, Reliability Prediction, Fatigue of Metals, Cumulative Damage, etc. As these topics were common to the past and the present investigations, it was not necessary to repeat them in the current study. Therefore, in the present project, no literature search was made.

## 4.2 THEORETICAL ANALYSIS

One of the objectives of this investigation was to develop and evaluate an analytical expression for the interference of two distributions. When the two distributions are Normal the interference can be simply expressed by a z-distribution, as described in Section 2. From an extensive survey of literature made in our past investigation, no work was found dealing with the analytical expression for interference when the two interfering distributions are not Normal. The purpose of this phase of the investigation, then, was to develop such expressions.

In the past investigation the analytical expressions and, hence, the tables of interference values, were developed by means of the Method of Integrals as discussed in Section 2.4 of Reference 1. These included:

<u>Stress Distribution</u>	<u>Strength Distribution</u>
Normal	Normal
Weibull	Weibull
Normal	Weibull

In the present investigation, data analysis (Section 6) revealed cases where fatigue strength data followed distributions other than Weibull or Normal. Hence it was necessary to develop tables of interference values for cases where stress distribution was Normal and strength distribution was Largest Extreme Value and, also, stress Normal and strength Smallest Extreme Value. This was done by evaluating the complex integrals expressing the distribution of interference. Numerical analysis was carried out (Appendix 3) using an IBM 360 computer to solve these integrals. Tables were then prepared for the interference values as a function of the distribution parameters (Appendix 2).

In addition, in the present investigation it was necessary to extend the scope of study for the case when the stress distribution is Normal and the strength distribution is Weibull. In the past investigation on ferrous materials<sup>(1)</sup>, the study was limited to the cases where the stress-strength interference parameter, C

$$C = \frac{\theta - X_0}{\sigma} = \frac{\text{strength index}}{\text{stress index}}$$

was between 10 and 100. This was because the strength data on ferrous materials fell into this range of C values. In the present investigation on the strength data of non-ferrous materials, C values fell between 1.0 and 10.0 in many cases. Hence, it was necessary to extend the interference tables to include values of C between 1.0 and 10.0. Thus, tables of interference values were prepared to include the combinations:

<u>Stress Distribution</u>	<u>Strength Distribution</u>
Normal	Weibull (Extended)
Normal	Largest Extreme Value
Normal	Smallest Extreme Value

These tables are given in Appendix 2.

#### 4.3 EMPIRICAL DATA

The tables of interference values are the heart of the Interference Theory as applied to engineering practice. Once the stress distribution and strength distribution parameters are known, the percent interference, and thus the probability of failure, can be read directly from these tables (for the procedure see Section 9 and for the tables see Appendix 2).

Over 250 articles from literature and other sources were examined in the past investigation, and practically no data were found concerning the statistical distribution of stress. In the present investigation some further work was done in this area, but no additional information was found. The only data located referred to spectrum of loads or stresses, which, as pointed out in Section 7, does not represent the stress distribution required for the Interference Theory. Interference Tables, therefore, were constructed so that, for given dispersion characteristics of stresses, a percent interference can be found. The range of these characteristics chosen here and corresponding to engineering practice are (if the stress distribution is Normal):

$$.01 \leq \frac{\sigma}{\mu} \leq .10$$

To determine the distribution of strength it was necessary to collect a great deal of data in order to arrive at a meaningful distribution. To systematize the effort of collecting data, a format was prepared which included the factors which are known to affect the final distribution of strength. An attempt was made to collect data in different areas in order to determine the effect of such factors as type of loading, size, processes, surface conditions, heat treatment, surface environment, temperature, surface treatment, stress concentration, etc.

The Mechanical Properties Data Center in Traverse City, Michigan, was found to be a very useful source of information for the fatigue strength data. They have been very cooperative in providing the necessary information. An exhaustive collection of data on the fatigue strength of non-ferrous materials was made from the Mechanical Properties Data Center. These data were then

systematized, evaluated in terms of the distribution parameters (Section 6), tabulated (Appendix 1), and the representative ones plotted (Section 6).

#### 4.4 FACTORS AFFECTING THE STATISTICAL DISTRIBUTION OF FATIGUE STRENGTH

Since fatigue strength represents the major interest in the engineering applications of the Interference Theory, this problem was studied in some detail. The statistical distribution of the fatigue strength of a mechanical component is a function of a number of factors, such as type of loading, surface finish, stress concentration, heat treatment, temperature, environment, size of specimen, frequency of loading, surface treatment, manufacturing processes, grain size, impurities, and time. Each shows variability which is characterized by some form of a distribution. The effects of these factors on the statistical distribution of strength were studied in the present investigation.

Fatigue strength can be defined as the maximum stress that can be sustained for a specified number of cycles without failure, the stress being completely reversed within each cycle. In the case of steels, a component is said to have finite fatigue strength if it fails between  $10^3$  and  $10^6$  or  $10^7$  cycles due to a given magnitude of cyclic load. For non-ferrous materials this is generally extended to  $5 \times 10^8$  cycles. In the present investigation the data were extrapolated to  $10^8$  cycles.

**Type of Loading:** The three major types of fluctuating load encountered in designing parts are axial, bending, and torsion. Experimentally determined values of the ratio of average fatigue strength for axial loading as compared to bending load were reported in literature as ranging generally from 0.75 to 1.0.<sup>(4,5)</sup> Although a great deal of work has been done to obtain precise values for this ratio, no detailed study has ever been made as to the statistical aspects of these strengths. Investigations have been conducted to find statistical distributions (Normal, Exponential, Weibull, etc.) of fatigue strength tested under a given type of loading, such as bending. No work was done to determine the effect on the distribution if the loads were other than bending. In the present investigation, an attempt was made to study the effect of different loads on the statistical distribution of the fatigue strength. The statistical parameters of the distribution for various materials under different loads were determined, tabulated according to materials (Appendix 1), and plotted in Section 6.

**Surface Finish:** The surface finish of a part does affect its endurance strength. Hence, the condition of finish should be taken into account when the design is based on fatigue. Surfaces which have an effect on the significant strength can be classified into five broad categories: polished, ground, machined, hot-rolled, and as-forged. The worse the surface condition the lower will be the mean fatigue strength but the higher will be the scatter. As a result, the degree of interference is likely to be pronouncedly affected by the type of surface finish imparted to the member. Different surface effects were studied in the present investigation and the fatigue strength parameters were tabulated (Appendix 1) and plotted in Section 6.

**Stress Concentration:** A notch or a stress raiser in a part subjected to fatigue loading can be regarded as a factor causing a local increase in stress or a reduction in strength. For example, a notch with a stress concentration factor of 2 can be thought of as doubling the stress or as halving the strength. In the present investigation this factor was taken as a strength reduction factor.

If all parts were made of materials which are completely homogeneous and have perfectly polished surface finishes, the effect of a notch would be to increase the stress by the factor  $K_t$ . Since actual materials are not perfectly homogeneous and actual surfaces are seldom perfectly polished, there exist internal and surface stress raisers. For this reason, the addition of a notch to a part, already having stress concentration due to geometry, generally produces a smaller effect than would be predicted from the theoretical stress concentration factor,  $K_t$ . The extent to which a notch reduces the endurance limit of a part is referred to as the fatigue stress concentration factor, or the fatigue strength reduction factor, and is designated by the symbol  $K_f$ . This is defined as:(6)

$$K_f = \frac{\text{endurance limit of specimen without the notch}}{\text{endurance limit of specimen with the notch}}$$

In this study, an attempt was made to determine the effect of stress concentration on the statistical scatter of the fatigue strength. More specifically, the objective was to find out whether this factor changes the mean strength only, whether it has an effect on the standard deviation, or whether it completely changes the nature of the distribution itself. The data were collected for various materials, various stress concentrations, and at different temperatures. Changes in the parameters of the statistical distribution of the strength due to the effect of stress concentration for different materials at various testing temperatures are tabulated in Appendix 1 and plotted in Section 6.

**Heat Treatment:** Different heat treatments such as annealing, solution heat treating, normalizing, quenching, tempering, aging, etc., can be imparted to materials to change their mechanical properties. Heat treatment may change the average fatigue strength but also the statistical scatter. Pertinent parameters are tabulated in Appendix 1 and plotted in Section 6.

**Temperature:** In a similar manner the effect of temperature on the statistical scatter of fatigue strength is shown in Appendix 1 and Section 6.

**Environment:** The effect of environment on the fatigue strength was confined in this investigation to the corrosive environment since most of the empirical strength data was in this area. It is known that a corrosive environment has a significant effect on the fatigue strength, particularly at a higher life. The statistical distribution parameters for various non-ferrous materials under different corrosive environments were determined, tabulated according to materials (Appendix 1), and plotted (Section 6).

Other Factors: In the present study it was observed that size and frequency of loading do not have any consistent effect on the distribution of the fatigue strength, whereas surface treatment, manufacturing processes, and impurities do exhibit consistent effects. The reason is that the latter may change the microscopic structure which, in turn, is related to strength. The statistical distribution parameters for various non-ferrous materials under the above conditions were determined, tabulated (Appendix 1) and plotted (Section 6).

#### 4.5 COMPUTER ANALYSIS OF STRENGTH DATA

Data collected during this phase of the investigation were organized and systematized according to materials and conditions. A computer approach was developed to analyze these data (Section 6). In the past investigation using the graphical approach, only the Weibull distribution was used in the data analysis for the reasons discussed in Reference 1. In the present investigation, with the aid of the computer, other distributions besides Weibull, such as Largest Extreme Value, Smallest Extreme Value, and Normal, were tried. The reasons for the selection of these particular distributions are given in Section 6.3. The best fitting distribution and its parameters were determined for various materials and conditions and these are tabulated according to materials in Appendix 1.

## SECTION 5 ANALYTICAL EXPRESSIONS FOR INTERFERENCE

## 5.1 INTRODUCTION

5.1.1 Interference Probabilities

In interference theory one supposes that the strength of a manufactured part is not known with certainty prior to performing some test on it and that the stress induced by a load is not known with certainty prior to actually loading the part. Thus, for example, one does not know with certainty that the strength of a part is exactly 50 ksi. He may know that the part cannot have a strength greater than 58 ksi or less than 40 ksi. Or he may know that the average strength that has been obtained in previous tests on these parts is 49 ksi. He may have some measure of how dispersed the strength measures are around this average strength. The point, of course, is that this type of knowledge is quite different from knowing precisely what the strength is prior to testing. For a multiplicity of reasons, strengths of seemingly identical parts are not exactly the same, and precisely what strength a part will have cannot be known until some type of strength test is performed. In the theory of probability one says that the strength of a part is a random variable. Certainly the same type of reasoning applies to the stress. Thus for a mathematical theory of interference one starts with the idea that strength is a random variable, say  $X$ , and stress is a random variable,  $Y$ .

In describing the properties of random variables, since their values are not known exactly, one supposes that, associated with every set of values that the random variable can take, there is a real number called the probability that the random variable takes values in the set. These probabilities are non-negative real numbers, they are all less than 1 and in the sense given below they "sum" to 1.

If  $x$  is any real number then there is a probability that the random variable takes some value less than or equal to  $x$ . Symbolically,

$$\Pr(X \leq x)$$

is a number such that  $0 \leq \Pr(X \leq x) \leq 1$ . Surely (i.e. with probability 1)  $X \leq \infty$  so that

$$\Pr(X \leq \infty) = 1,$$

and

$$\Pr(-\infty > X) = 0.$$

Clearly  $\Pr(X \leq x)$  depends on the real number  $x$ . Consequently one defines a probability distribution function,  $F(x)$ , by the relation

$$F(x) = \Pr(X \leq x).$$

One sees immediately that

$$\begin{aligned} 0 &\leq F(x) \leq 1, \\ F(-\infty) &= 0 \\ F(\infty) &= 1 \end{aligned}$$

and that  $F(x)$  is a non-decreasing function.

In most engineering applications  $F(x)$  has a derivative for every value of  $x$ , and one defines the probability density function,  $f(x)$ , by

$$f(x) = \frac{dF(x)}{dx} .$$

One takes  $f(x)dx = \Pr(x < X \leq x + dx)$ .

(i.e. the probability density function multiplied by  $dx$  is the probability that  $X$  takes values in the neighborhood of  $x$ .) Since

$$f(x)dx = dF(x) ,$$

one has

$$\int_{-\infty}^{\infty} f(x)dx = \int_{-\infty}^{\infty} dF(x) = F(x) \Big|_{-\infty}^{\infty} = 1$$

the probabilities given by  $f(x)dx$  "sum" to 1.

In the mathematical theory of interference one assumes that the probability density function for the random variables  $X$ (strength) and  $Y$  (stress) are known. Sections 6 and 7 following show how these functions can be found from engineering data. Thus the "givens" of the mathematical theory of interference use the random variables  $X$  and  $Y$ , the set of values that they each can take (usually the non-negative real line), and the probability density or distribution function  $F(x)$  [or  $f(x)$ ] and  $G(y)$  [or  $g(y)$ ].

The problem to which interference theory addresses itself is that of finding the probability of failure. Failure is said to occur whenever the stress exceeds strength. Thus from the known probabilities for the  $X$  and  $Y$  random variables one wishes to find

$$\Pr(Y \geq X) ,$$

which is the probability that stress exceeds strength or the probability of failure.

### 5.1.2 Calculation of Probabilities of Failure

There are two useful ways of determining the probability of failure from the known properties of  $X$  and  $Y$ .

(a) Since one wishes to find  $\Pr(Y \geq X)$  it is convenient in some cases (e.g. when stress and strength are normally distributed) to define a new random variable,  $Z$ , by the relation

$$Z = X - Y .$$

Then if one can find the probability density function of  $Z$ ,  $h(z)$ , the probability of failure will be simply the probability that  $z \leq 0$ . In terms of  $h(z)$  this is found by

$$\Pr(\text{failure}) = \int_{-\infty}^0 h(z) dz .$$

The problem in general is then to find  $h(z)$  from the known probability density functions  $f(x)$ ,  $g(y)$ . A complete discussion of this method and its applications is found in Section A-3.2 of Reference [1].

In the important special case in which both stress and strength are normally distributed random variables it is well known that  $Z$  is also normally distributed with parameters.

$$\mu_Z = \mu_X - \mu_Y$$

and

$$\sigma_Z^2 = \sigma_X^2 + \sigma_Y^2$$

Consequently the probability of failure can be found directly from tables of the normal curve areas. One wants the area from  $-\infty$  to 0 from these tables. A complete discussion of how to do this is given in Section 2.

(b) For most applications method (a) above is unnecessarily complex because one must first find the entire density function of the random variable  $Z$  before finding the probability of failure. Since the random variable  $Z$  is of no practical value for  $Z < 0$ , the approach in part (a) is unduly long. The methods described in this section are more direct and, from our experience, more useful in general.

One can derive the probability of failure as follows. Suppose we superimpose the stress and strength density function on the same graph as shown in Figure 5.1.

Although  $Y$  is a random variable, let us fix attention on a particular, small interval that  $Y$  can take values in. Let us fix  $y < Y \leq y + dy$ . Then let us find the probability that the random variable  $X$  takes values less than this fixed  $Y$ . One can show that this probability is

$$\Pr(X \leq y \mid y < Y \leq y + dy) = \int_0^y f(x) dx .$$

The left hand side of this expression is called a conditional probability. It is the probability that the random variable  $X$  takes values less than the real number  $y$  when it is known ("given that") the random variable  $Y$  is "nearly"  $y$ .



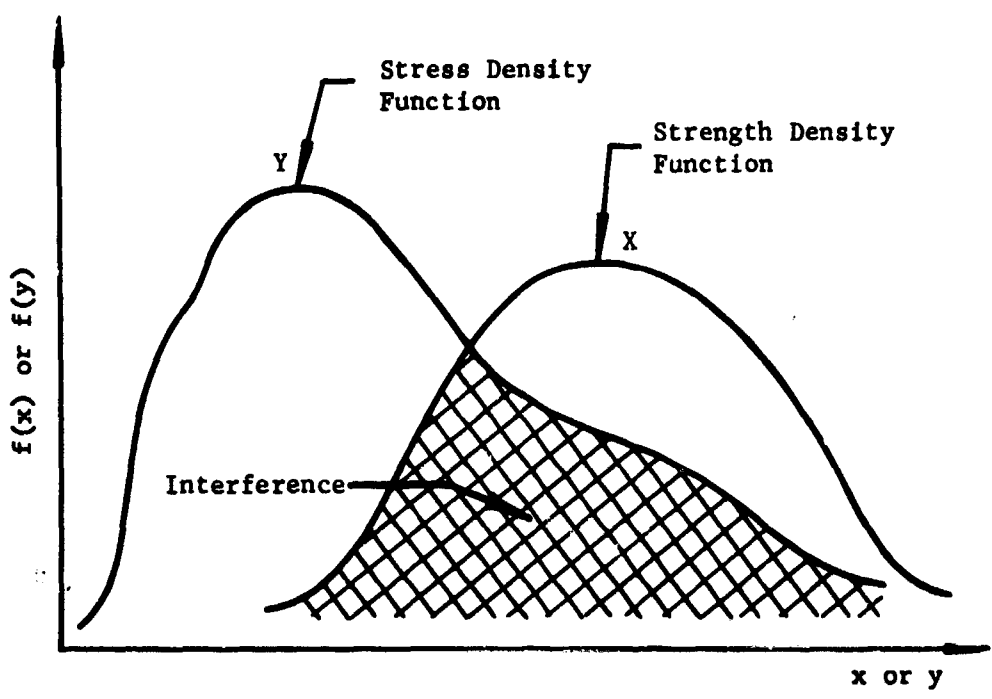

Figure 5.1 Interference of Stress and Strength Distributions

By the definition of  $f(x)$ , this probability is obviously the same as the right hand side of the expression. If now we multiply this conditional probability by

$$\Pr(y < Y \leq y + dy) = g(y)dy ,$$

we obtain the joint probability that  $X \leq y$  and  $y < Y \leq y + dy$  which symbolically is

$$\Pr(X \leq y \mid y < Y \leq y + dy) \Pr(y < Y \leq y + dy)$$

$$= \Pr(X \leq y; y < Y \leq y + dy) .$$

This probability is given by the integral

$$\int_0^y f(x)dx \quad g(y)dy .$$

From the joint probability one obtains the probability of failure by:

$$\Pr(\text{failure}) = \int_0^{\infty} \int_0^y f(x) g(y) dx dy .$$

Thus this double integral gives the probability of failure directly.

If one recalls the relation between  $f(x)$  and  $F(x)$ , it is clear that the double integral is easily reduced to the single integral

$$\Pr(\text{failure}) = \int_0^{\infty} F(y) g(y) dy .$$

If  $F(x)$  is easily obtainable then this expression is easier to work with than the double integral. For example, one knows that for a strength with a Weibull probability density function the probability distribution function  $F(x)$  is given by

$$F(x) = 1 - e^{-\left(\frac{x-x_0}{\theta_x-x_0}\right)^{b_x}}$$

In these cases the probability of failure is then given by

$$\begin{aligned} \Pr(\text{failure}) &= \int_0^{\infty} \left(1 - e^{-\left(\frac{y-x_0}{\theta_x-x_0}\right)^{b_x}}\right) g(y) dy \\ &= 1 - \int_0^{\infty} e^{-\left(\frac{y-x_0}{\theta_x-x_0}\right)^{b_x}} g(y) dy . \end{aligned}$$

The latter expression follows because

$$\int_0^{\infty} g(y)dy = 1$$

if the random variable  $Y$  takes only positive values which is the usual case in interference theory.

### 5.1.3 Interference Tables, Appendix 2

In Section 5.1.2 it was shown that the probability of failure could be expressed as an integral involving the known probability density or distribution functions. In certain cases this integral can be evaluated in closed form (e.g. when  $f(x)$  and  $g(y)$  are both exponential functions). In some cases this integral can be evaluated in terms of other well known and tabulated functions (e.g. when  $f(x)$  and  $g(y)$  are both gamma functions or when  $f(x)$  and  $g(y)$  are both normal functions). In general it is not to be expected that the integral for the probability of failure can be evaluated in closed form or in a form involving other well known functions. (e.g. when  $f(x)$  and  $g(y)$  are both Weibull functions or when  $f(x)$  is a Weibull function and  $g(y)$  is a normal function.) In those cases one must resort to numerical evaluation of the integral.

Since the integrals giving the probability of failure cannot be expressed in terms of well known functions, in general, we have evaluated the integral numerically. Tables of the probability of failure are given in Section A-2 of [1]. A full discussion of the numerical methods used and the errors of approximation appropriate to the tables are given in Section A-4 of [1].

Additionally, one is interested in the case in which the strength distribution is of the form

$$1 - e^{-e^{\beta(x-M)}} \quad \text{when } \beta > 0, \\ -\infty \leq x \leq +\infty,$$

called the Smallest Extreme Value probability distribution function. One is also interested in the case in which strength is distributed as

$$e^{-e^{-\beta(x-M)}} \quad \text{when } \beta > 0, \\ -\infty \leq x \leq +\infty,$$

which is called the Largest Extreme Value probability distribution function.

Section A-2.2 gives the probability of failure for the case in which strength is Weibull distributed and stress is normally distributed.

Section A-2.5 gives the probability of failure for the case in which strength is distributed with the Smallest Extreme Value distribution function and stress is normally distributed.

Section A-2.4 gives the probability of failure for the case in which strength is distributed with the Largest Extreme Value distribution function and stress is normally distributed.

## 5.2 USE OF INTERFERENCE TABLES IN APPENDIX 2

### 5.2.1 Parameters for the Weibull Distributed Strength, Normal Distributed Stress

The form for the integral involved in finding the probability of failure when the strength is Weibull distributed and the stress is normally distributed is given in Section A-3.3.5 of [1]. Tables of these probabilities are given in Section A-2.1 of [1]. A discussion of the numerical analysis, error and accuracy of the tables is given in Section A-4.1.7 of [1].

The form of the distribution of the strength has been given in Section 5.2.1 of [1].

In the past investigation, extensive tables of interference values (Section A-2.1.2 of [1]) were prepared for the parameter C (as defined below) equal to 10 or above. In the present investigation on non-ferrous materials, the values of parameter C much lower than 10 were needed. Hence, the Tables A-2.1.2 of [1] were extended to cover the range of  $1 \leq C < 10$ . Therefore, the Tables of this report list probabilities of failure for

$$B(x) = 1, 1.2, 1.3, \dots 3.2$$

$$C = 1., 2., \dots 10.$$

$$A = 0, .2, .4, \dots 2.8 \text{ and } -.2 \text{ to } -10.0$$

where

$b_x$  = the slope of the strength distribution. In the tables this is called B(x).

$(\theta_x - x_0)/\sigma$  = the ratio of the difference of the characteristic strength and the truncation parameter (or lower bound of strength) to the standard deviation of the stress. In the tables this is called C for typographical simplicity.

$(x_0 - \mu)/\sigma$  = the difference between the strength truncation parameter and the mean stress divided by the standard deviation of the stress. In the tables this is called A for simplicity.

The values in the body of the table are the probabilities of failure for the parameters given at the heading of the tables. From the discussion given in Section A-4.1.7 of [1] these probabilities are correct to  $\pm 5 \times 10^{-5}$ .

### 5.2.2 Parameters for the Smallest Extreme Value Distributed Strength, Normal Distributed Stress

In this case it has been found that the integral giving the probability of failure can be expressed in terms of two parameters which are denoted by

$\alpha$  and  $\gamma$ . In the tables these parameters are given by

$\gamma = \beta(\mu - M)$  = the difference in the location parameter ( $\mu$ ) for the normally distributed stress and the mode ( $M$ ) for the Smallest Extreme Value distributed strength. This difference is multiplied by  $\beta$ , the slope parameter of the extreme value distribution.

$\alpha = \beta\sigma$  = the product of the standard deviation of the Normal distribution for the stress variable and the slope parameter for the Smallest Extreme Value distributed strength.

The tables give the probability of failure for

$\alpha$ : .001, .005, .025, .05, .075, and .1 to 3.0 in steps of 0.1 and 3.5 to 10 in steps of 0.5.

$\gamma$ : 0 to -40 in steps of 1.0

The values in the tables give the probability of failure corresponding to the values of  $\alpha, \gamma$  given at the column and row heads. These probabilities are correct to within  $\pm 2 \times 10^{-4}$  according to the discussion given in Section A-3.

#### 5.2.3 Parameters for the Largest Extreme Value Distributed Strength, Normal Distributed Stress

In this case, the integral expressing the probability of failure is almost identical to that in the previous case (Section 5.2.2). The definitions of the parameters  $\alpha$  and  $\gamma$  are identical. The tables give probabilities of failure for the ranges of  $\alpha$  and  $\gamma$  listed in Section 5.2.2. These probabilities are also correct to  $\pm 2 \times 10^{-4}$  as discussed in Section A-3.

#### 5.2.4 Use of the Tables, Explanation of Missing Values and Interpolation

Numerical examples of the use of the tables are given in Section 9. In general the user will enter the table with known parameters, for example,  $b, \theta_x, x_0$ , and the appropriate parameters for the stress distribution, and wish<sup>x</sup> to find the probability of failure. This is a direct table look-up. In some design problems the user will have a given probability of failure to achieve and will know the general shape of the distribution of stress and strength appropriate to the material that he is using. The table will then give him the relative parameters (there may be many of these) to design for. It would be expected that a cost analysis would give the acceptable parameter values for each distribution. As long as the relative values are as given in the table, the probability of failure will be the same no matter what the values for each distribution are.

In the Weibull Strength-Normal Stress tables, the missing values within the ranges of the parameters used are nearly zero and hence have not been tabulated. When  $A = (x_0 - \mu)/\sigma > 3.5$ , the probability of failure is less than  $1 \times 10^{-4}$  since the area under the normal curve from 3.5 to  $\infty$  is less than  $3 \times 10^{-4}$ .

For the Normal-Extreme Value cases, the probabilities of failure are zero (to 4-places) whenever  $\gamma < -39$  and  $\alpha < 10$ .

When  $\alpha = \beta\sigma = 0$  (or  $\sigma = 0$ ), then the stress distribution for either the Normal-Smallest Extreme Value or Normal-Largest Extreme Value case is a straight-line distribution, and the probabilities of failure can be computed as in Appendix 2. These formulas are repeated here since they give very good approximations for the probabilities even when  $\alpha \neq 0$  but is small (say  $\alpha < .001$ ).

For  $\alpha = 0$ :

$$\begin{aligned} \text{Pr [failure]} &= 1 - e^{-e^{\gamma}} \\ \text{(Normal-Smallest)} & \\ & \quad \quad \quad \gamma \text{ where } \gamma = \beta(\mu - M) \\ \text{Pr [failure]} &= e^{-e^{\gamma}} \\ \text{(Normal-Largest)} & \end{aligned}$$

It can be seen that the tables are non-linear for almost all values of the parameters. This can cause inaccuracies when the tables are interpolated. The absolute value of the interpolation error depends on which tables are interpolated. For precise values the user should use a higher order interpolation formula (as given in Section A-2.1) rather than linear interpolation. We have not explored the relative errors of interpolation closely. In those cases checked, the relative errors are small.

## SECTION 6 STATISTICAL DISTRIBUTION OF FATIGUE STRENGTH BY COMPUTER APPROACH

Most fatigue testing involves subjecting specimens or parts to a fluctuating stress to failure and repeating this process at various stress levels. The data thus obtained, known as life data, are used to construct the conventional S-N diagram. In this case, the scatter obtained is the scatter in life at a given stress. In the present investigation the attention was focused on the nature of the scatter in fatigue strength at a given life. In the past investigation<sup>(1)</sup>, where the study was made mainly on the ferrous materials, the problem of determining the scatter in the fatigue strength and, subsequently, its distribution function was resolved by a graphical method discussed in Reference 1. Among the several possible distribution functions that were considered, only the Weibull distribution was used because of its wide use and the difficulty of handling other distributions by a graphical method. In the present investigation on the non-ferrous materials a computer approach was developed by which the determination of the distribution functions of strength became considerably less difficult. Consequently, it was possible to try out such other distributions as Largest Extreme Value, Smallest Extreme Value, Logistic, and Normal besides the Weibull which was tried in the past investigation. The reasons for selection of these particular distributions are given in Section 6.3. The computer program was so developed that when the raw data (conventional S-N type data) were fed into this program, the computer printed the degree of fit and the parameters for all the above distributions for a given set of strength data. In the first part of this program the scatter in the life was converted into the scatter in the fatigue strength. In the second part, the distribution functions (Weibull, Normal, Logistic, Largest Extreme Value, and Smallest Extreme Value) were fitted to these strengths data simultaneously, and the one with the highest degree of fit was the best fitting distribution. The detailed discussion on this computer approach and the necessary statistical tools that were used in developing the approach are given in the following sections. The flow chart of the computer program used to determine the fatigue strength distribution is given in Appendix 4.

### 6.1 LEAST SQUARES METHOD OF FITTING A LINE TO S-N TYPE DATA

#### 6.1.1 Method of Least Squares

The principle underlying the "best fit" of a line by the least squares method is that the sum of the squares of the deviations in the y-direction of the data points  $(X_i, Y_i)$  from the most probable line is minimum (See Figure 6.1). The equation of this line is:

$$Y = \alpha + \beta X \quad (6.1)$$

where  $\alpha$  is intercept on Y-axis

and  $\beta$  is the slope of the line.

The parameters  $\alpha$  and  $\beta$  are found from the following relationships<sup>(2)</sup>:

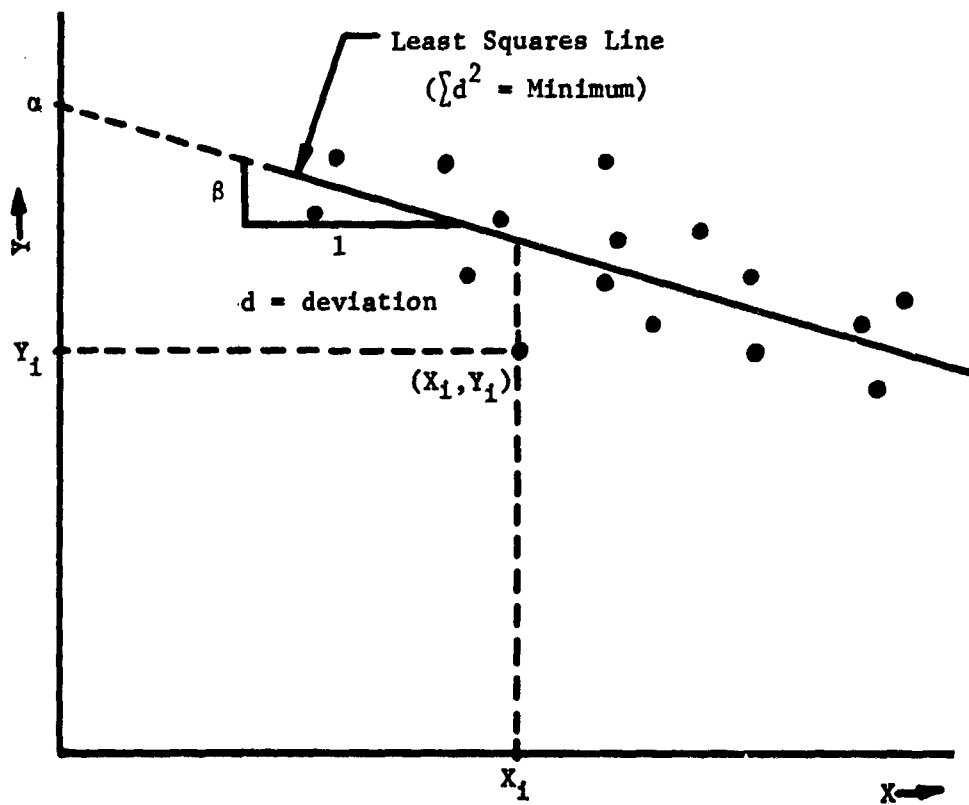

Figure 6.1 Least Squares Line



$$\beta = \frac{\sum_{i=1}^n Y_i X_i - \sum_{i=1}^n X_i \sum_{i=1}^n Y_i}{\sum_{i=1}^n X_i^2 - \left[ \sum_{i=1}^n X_i \right]^2} \quad (6.2)$$

$$\alpha = \frac{\sum_{i=1}^n Y_i - \beta \sum_{i=1}^n X_i}{n} \quad (6.3)$$

where  $n$  = the total number of points

$X_i$  = abscissas of points

$Y_i$  = ordinates of points

#### 6.1.2 Application of Least Squares Method to S-N Data

When stress-life (S-N) data are plotted on a log-log paper or log (S) and log (N) are plotted on a Cartesian paper, an approximately straight line results. Hence, the S-N data are related by the equation:

$$\ln (S) = \alpha + \beta \ln (N)$$

When  $\ln (S)$  and  $\ln (N)$  are substituted for  $Y$  and  $X$  in the Equations (6.2) and (6.3), they reduce to:

$$\beta = \frac{n \left( \sum_{i=1}^n (\ln N_i)(\ln S_i) \right) - \left( \sum_{i=1}^n \ln N_i \right) \left( \sum_{i=1}^n \ln S_i \right)}{n \left( \sum_{i=1}^n (\ln N_i)^2 \right) - \left( \sum_{i=1}^n \ln N_i \right)^2} \quad (6.4)$$

$$\alpha = \frac{\sum_{i=1}^n (\ln S_i) - \beta \sum_{i=1}^n \ln N_i}{n} \quad (6.5)$$

where  $\alpha$  and  $\beta$  are the intercept and the slope of the S-N line (See Figure 6.2)

$n$  = the total number of test points

$N_i$  = the  $i^{\text{th}}$  life, corresponding to the  $i^{\text{th}}$  stress,  $S_i$

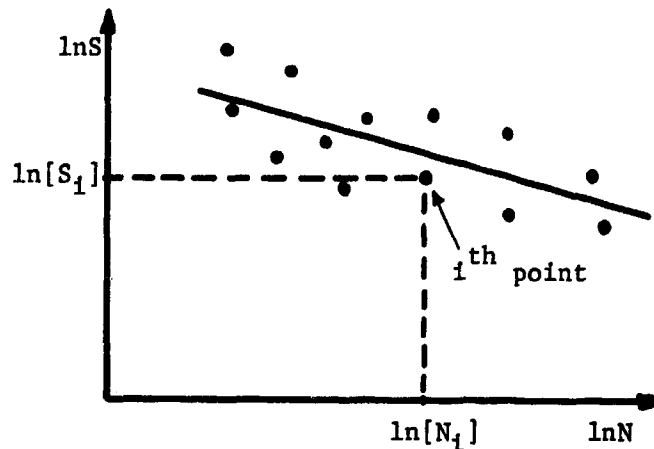

Figure 6.2 lnS - ln N Diagram

### 6.1.3 Correlation Coefficient

Correlation Coefficient (R) is an index of the goodness of fit of the least squares line to a set of data. In the previous section it was pointed out that a straight line can be fitted to a set of data with known coordinates, for example, ln (S) and ln (N). This section deals with a computation of correlation coefficient (R) which is a measure of the goodness of fit. The correlation coefficient is defined as:

$$R = (\beta)^2 \frac{S_x^2}{S_y^2} \quad (6.6)$$

where  $\beta$  = the slope of the fitted line.

$$S_x^2 = \frac{n \sum_{i=1}^n X_i^2 - \left( \sum_{i=1}^n X_i \right)^2}{n(n-1)} \quad \begin{array}{l} \text{Sample variance of X} \\ \text{(abscissas)} \end{array} \quad (6.7)$$

$$S_y^2 = \frac{n \sum_{i=1}^n Y_i^2 - \left( \sum_{i=1}^n Y_i \right)^2}{n(n-1)} \quad \begin{array}{l} \text{Sample variance of Y} \\ \text{(ordinates)} \end{array} \quad (6.8)$$

If the correlation coefficient (R) is 1.0, every data point falls on the least square line and the data has the best fit. On the other hand, if the correlation coefficient (R) is equal to zero, all the data are around a circle and the data has very poor fit. (See Figure 6.3)

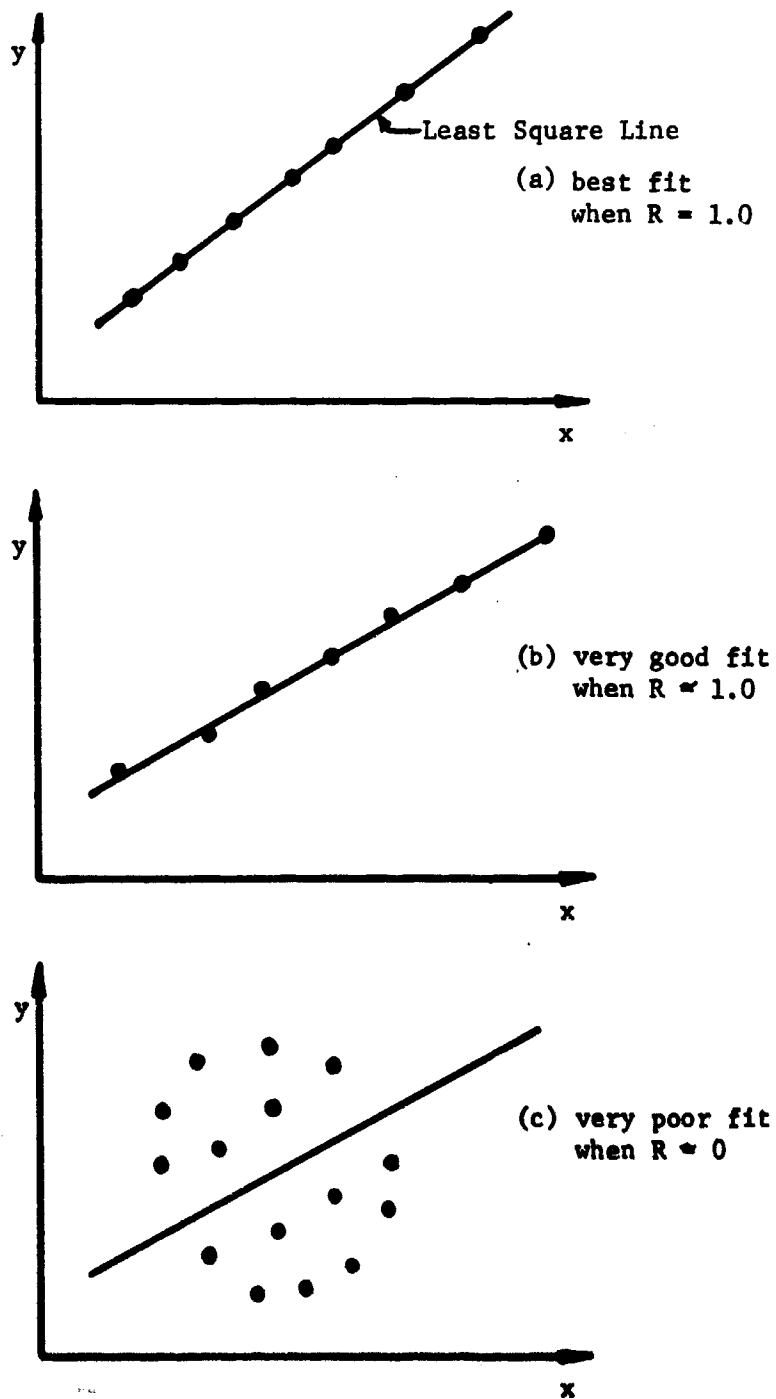

Figure 6.3 Goodness of Fit for Various Correlation Coefficients (R)

Five distributions (Weibull, Normal, Logistics, Largest Extreme Value, and Smallest Extreme Value) were fitted to each set of the fatigue strength data, and the values of the correlation coefficient (R) for each fitted distribution were computed from Equation (6.6). The distribution having the largest value of R was taken as the best fitting distribution.

## 6.2 CONVERSION OF LIFE DATA TO STRENGTH DATA

In the past investigation<sup>(1)</sup> on ferrous materials the conversion of life data to strength data was accomplished graphically where the data were plotted on the conventional S-N diagram and the least squares S-N curve was then fitted to the test points. Passing through each point an S-N curve parallel to the least squares curve was drawn. These made a set of parallel S-N lines. (See Figure 6.4). A vertical line was drawn at a given life, say  $N_1$ , intersecting the family of S-N curves. The points of intersection  $S_1, S_2, S_3 \dots$  represent the scatter of the fatigue strength at the life  $N_1$  (See Figure 6.4). Here, it was assumed that to each specimen of the population can be attributed an individual S-N curve, and that there exists for any population of specimens (at fixed test conditions) a family of non-intersecting S-N curves which can be determined with any desired accuracy, each curve corresponding to a given probability.

In the present investigation on non-ferrous materials, this basic assumption was held still true, and for the purpose of developing the computer approach, it was necessary to develop an analytical approach for the above graphical method. This is given in the following sections.

### 6.2.1 Computation of Parallel S-N Lines

The general form of the equation of the parallel S-N curves is:

$$\ln S = \alpha_1 + \beta \ln N \quad (6.9)$$

where  $\beta$  is the slope of the lines as computed from Equation (6.4)

$\alpha_1$  is the intercept of the line passing through a given point  $(N_1, S_1)$

and  $i$  is the subscript which takes values from 1 to  $n$  where  $n$  is the number of parallel lines

In order to determine the equation of each line, it was necessary to compute the corresponding values of  $\alpha_1$  from the following equation:

$$\alpha_1 = (\ln S_1) - \beta (\ln N_1) . \quad (6.10)$$

By substituting the values of S-N data,  $(S_1, N_1), (S_2, N_2), (S_3, N_3) \dots$ , in Equation (6.10),  $\alpha_1, \alpha_2, \alpha_3 \dots$  can be computed. Hence, using Equation (6.9), a set of equations for each parallel line was obtained.

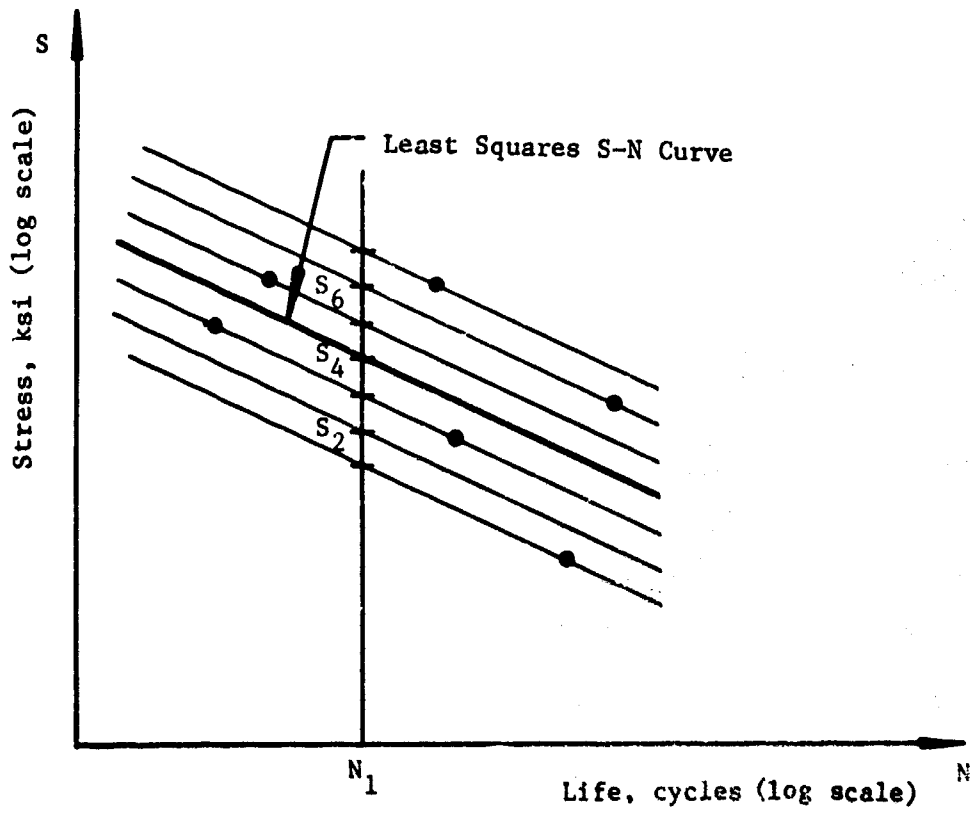

Figure 6.4 S-N Diagram for converting Life Data to Strength Data

$$\begin{aligned} \ln S &= \alpha_1 + \beta \ln N \\ \ln S &= \alpha_2 + \beta \ln N \\ \ln S &= \alpha_3 + \beta \ln N \end{aligned} \quad (6.11)$$

### 6.2.2 Computation of the Scatter of Strength at a Given Life

A life, say  $N_1$ , was chosen at which the scatter of strength was desired. By substituting  $\ln N_1$  in Equation (6.11), a set of values of  $\ln S_1$ ,  $\ln S_2$ ,  $\ln S_3 \dots$ , were obtained. By taking antilog of these values, the scatter of fatigue strengths  $S_1, S_2, S_3 \dots$  for the life  $N_1$  was obtained. This was repeated for several values of life  $N_j$ , and the resulting scatters of fatigue strengths,  $S_{ij}$ , were stored by computer for further analysis.

Median ranks<sup>(2)</sup> were then assigned to the scatter of the fatigue strength data,  $S_{ij}$ , arranged in increasing order. The analytical expression for the median ranks that was used for the computer programming was<sup>(7)</sup>:

$$\text{Median Rank} = \frac{j - .3}{n + .4}$$

where  $j$  = order number and

$n$  = total number of data points.

### 6.3 DISTRIBUTION FUNCTIONS

The most common probability distributions that were found from literature for expressing the fatigue strengths are: Weibull, Largest Extreme Value, Smallest Extreme Value, Normal, and Logistic. These cover a considerable variety of distribution patterns. For example, Weibull distribution generates a wide variety of distributions by choosing different values of its parameters,  $X_0$ ,  $\theta$ , and  $b$ , (this is discussed in the following section). Extreme Value distribution (Largest and Smallest) takes care of some of the unexplainable phenomenon observed in connection with the fracturing of materials under the applied dynamic load where the puzzling question is: Why is the strength of a specimen considerably smaller or larger than its expected value? The reason for this difference in the values lies in the fact that there may exist flaws in the specimen that will weaken it. Normal distribution was used for the obvious reason that it can be justly called the most common and well known distribution. Logistic distribution, which has somewhat the same characteristics as the Normal distribution, was tried, but later it was found from the computer results that Normal fits the data just as well as Logistic. Hence, in those cases where Logistic fitted the data best, the Normal was used, instead, to express the fatigue strength. Besides, Normal distribution is widely used and is easier to understand for engineers with little statistical background. It is for these reasons that the discussion on the Logistic distribution does not appear in the following section. Other distributions are discussed below.

### 6.3.1 Weibull Distribution

The Weibull equation is a three parameter function. The general expression for the Weibull density function is:

$$p(x) = \frac{b}{\theta - X_0} \left( \frac{x - X_0}{\theta - X_0} \right)^{b-1} e^{-\left( \frac{x - X_0}{\theta - X_0} \right)^b}, \quad (6.12)$$

$$X_0 \leq x \leq \infty$$

and the general expression for the cumulative distribution function is:

$$P(x) = 1 - e^{-\left( \frac{x - X_0}{\theta - X_0} \right)^b}, \quad X_0 \leq x \leq \infty \quad (6.13)$$

where, as used in this study,

$x$  is the independent variable (fatigue strength)

$X_0$  is the lower bound of fatigue strength

$\theta$  is the characteristic fatigue strength, where 63.2% of the population have strengths less than or equal to this value<sup>(2)</sup>

$b$  is the Weibull slope

### 6.3.2 Normal Distribution

Normal distribution is a two parameter function. The general expression for Normal density function is:

$$p(x) = \frac{1}{\sqrt{2\pi} \sigma} e^{-\frac{(x-\mu)^2}{2\sigma^2}}, \quad -\infty \leq x \leq +\infty \quad (6.14)$$

where  $x$  is the independent variable (fatigue strength)

$\mu$  is the population mean

$\sigma$  is the population standard deviation

By a simple transformation, this can be reduced to:

$$P(y) = \frac{1}{\sqrt{2\pi}} \int_{-\infty}^y e^{-\frac{z^2}{2}} dz \quad (6.15)$$

where  $z$  = standardized normal variate =  $\frac{x-\mu}{\sigma}$

and  $P(y)$  = probability of  $z \leq y$ .

### 6.3.3 Extreme Value Distributions

Gumble(8) designed what is known as the Extreme Value Distribution which is generally used to estimate the tail-ends of the frequency distributions. This distribution determines the probability of occurrence of an event. Largest values or smallest values of an event can be estimated by Largest Extreme Value distribution or Smallest Extreme Value distribution respectively. The general expression for the density function is:

Largest Extreme Value (L.E.V.):

$$p(x) = \beta e^{-\beta(x-M)} - e^{-\beta(x-M)} \quad (6.16)$$

$$= \beta e^{-\beta(x-M)} \cdot e^{-e^{-\beta(x-M)}}, \quad -\infty \leq x \leq +\infty \quad (6.17)$$

Smallest Extreme Value (S.E.V.):

$$p(x) = \beta e^{+\beta(x-M)} - e^{+\beta(x-M)}$$

$$= \beta e^{+\beta(x-M)} \cdot e^{-e^{+\beta(x-M)}}, \quad -\infty \leq x \leq +\infty \quad (6.18)$$

The general expression for the cumulative distribution function is:

Largest Extreme Value (L.E.V.):

$$P = e^{-e^{-\beta(x-M)}} \quad (6.19)$$

Smallest Extreme Value (S.E.V.):

$$P = 1 - e^{-e^{+\beta(x-M)}} \quad (6.20)$$

where  $\beta$  = intensity function (slope)

$M$  = Extreme Value (mode)

$\beta$  and  $M$  are also called the extremal parameters. Comparison of characteristics of Extreme Value distribution with Normal distribution is given in Table 6.1 which is self-explanatory.



Characteristic	Largest Value	Smallest Value	Normal Variate
----------------	---------------	----------------	----------------

A. Distribution

1. Cumulative probability function for reduced variate, $\phi$	$e^{-e^{-y}}$	$1 - e^{-e^y}$	$\int_{-\infty}^z \frac{1}{\sqrt{2\pi}} e^{-\frac{1}{2}t^2} dt$
2. Reduced variate -----	$y = \alpha(x-u)$	$y = \alpha(x-u)$	$z = \frac{1}{\sigma}(x-\mu)$
3. Original variate, $x$ , in terms of reduced variate ---	$x = u + y/\alpha$	$x = u + y/\alpha$	$x = \mu + \sigma z$

B. Reduced Variate  $y$

4. Moment generating function $G(t)$ -----	$\Gamma(1-t)$	$\Gamma(1+t)$	$e^{\frac{1}{2}t^2}$
5. Mode $\bar{y}$ -----	0	0	$\bar{z}=0$
6. Mean $\bar{y}$ -----	$\gamma=0.57722$	-0.57722	$\bar{z}=0$
7. Median $\bar{y}$ -----	$-1/\ln 2 = 0.36651$	-0.36651	$\bar{z}=0$
8. Standard deviation $\sigma$ -----	$\pi/\sqrt{6} = 1.28255$	1.28255	1
9. Skewness $\beta_1$ -----	1.29857	-1.29857	0
10. Kurtosis $\beta_2$ -----	27/5	27/5	3

C. Deviates  $y_\phi$  Corresponding to Given Probability Points  $\phi$



			
11. $\phi = .95$ -----	2.97020	1.09718	1.64485
12. $\phi = .99$ -----	4.60015	1.52718	2.32635

Table 6.1 Comparison of Characteristics of Extreme Value Distribution and Normal Distribution<sup>(8)</sup>

Characteristic	Largest Value	Smallest Value	Normal Variate
----------------	---------------	----------------	----------------

D. Area  $P_{K\sigma}$  Included Within Mode =  $K\sigma$

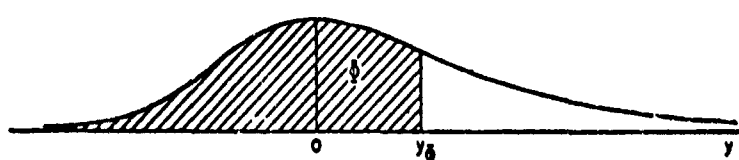

13. $K=1; P_{K\sigma}=\Phi(\sigma)-\Phi(-\sigma)$ -----	0.73064	0.73064	<u>0.68269</u>
14. $K=2; P_{K\sigma}=\Phi(2\sigma)-\Phi(-2\sigma)$ -----	0.92597	0.92597	<u>0.95450</u>
15. $K=3; P_{K\sigma}=\Phi(3\sigma)-\Phi(-3\sigma)$ -----	0.97890	0.97890	0.99730
16. Variate $y$ for which $P_y=0.68269$	1.14071	1.14071	1.00000
17. Variate for which $P_y=0.95450$ ---	3.06685	3.06685	2.00000

E. Original Variate,  $x$

18. Mode $\bar{x}$ -----	$u$	$-u$	$\mu$
19. Mean $\bar{x}$ -----	$u+\gamma/\alpha$	$-u-\gamma/\alpha$	$\mu+\sigma z=\mu$
20. Median $\bar{x}$ -----	$u+0.36651/\alpha$	$-u-0.36651/\alpha$	$\mu+\sigma z=\mu$
21. Standard deviation $\sigma_x$ -----	$\frac{1}{\alpha} \cdot \sigma = \frac{1}{\alpha} \cdot \frac{\pi}{\sqrt{6}}$	$\frac{1}{\alpha} \cdot \sigma = \frac{1}{\alpha} \cdot \frac{\pi}{\sqrt{6}}$	$\sigma \cdot 1$

Table 6.1 (Continued) Comparison of Characteristics of Extreme Value Distribution and Normal Distribution (8)

#### 6.4 THE LINEARIZING TRANSFORMATION EQUATIONS OF THE DISTRIBUTION FUNCTIONS

When  $x$ , the independent variable (in this case the fatigue strength), and  $P$ , the dependent variable (in this case the cumulative probability of the fatigue strength), are plotted on a Cartesian graph paper, the resultant plot is non-linear (sigmoidal or S-shaped plot) as shown in Figure 6.5.

Such a curve is difficult to work with. To fit this curve to a set of data it is necessary to use the curvilinear regression analysis. This analysis is quite involved as compared to the linear regression analysis which can be used to fit only the straight lines. Hence, if the non-linear function can somehow be transformed into a linear function, the linear regression analysis can be employed. This can be done by transforming the dependent ( $P$ ) and independent ( $x$ ) variables of the function to a new set of dependent [ $T(P)$ ] and independent [ $G(x)$ ] variables. This process is called the Linearizing Transformation. The functional relationships between the variables (independent and dependent) of the sigmoidal form of the distribution (Figure 6.5) and variables of the linear (Figure 6.6) form of the distribution are called the linearizing transformation equations. These are given as:

$$X = G(x) = \text{independent variable plotted on abscissa}$$

$$Y = T(P) = \text{dependent variable plotted on ordinate}$$

The linearizing transformation is used in many engineering applications. For example, in strength-life (S-N) diagrams with the ordinate and the abscissa having logarithm scale;

$$Y = \ln S$$

and  $X = \ln N$  are the linearizing transformation equations where  $\ln S$  and  $\ln N$  are called the linear mode variables and  $S$  and  $N$  are the original variables. Or, in case of Weibull distribution,  $\ln \ln \frac{1}{1-P(x)}$  and  $\ln (x - X_0)$  are the linear mode variables where as  $P(x)$  and  $x$  are the original (or non-linear mode) variables. In the analysis of fatigue strength data, linearization transformation can be stated as:

$$Y = T(P) \quad (6.21)$$

$$X = G(x) \quad (6.22)$$

where  $T$  and  $G$  are the linearizing transformation equations relating original variables  $P$  and  $x$  to linear mode variable  $Y$  and  $X$  respectively. The functions  $G$  and  $T$  should be such that the inverse transform operation on them gives the original variables. These inverse transformation equations are:

$$P = T^{-1} (Y)$$

$$x = G^{-1} (X).$$

The inverse transformation equations are important for finding the parameters of original distribution functions. This will be discussed in the section that follows.

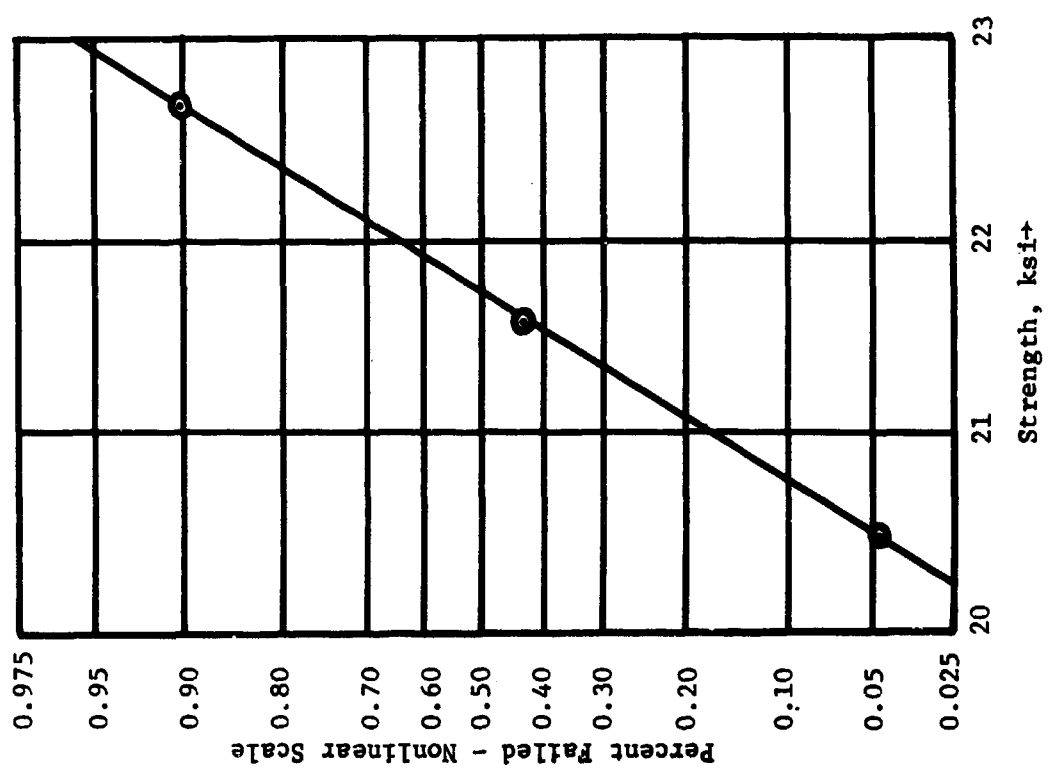

Figure 6.5 Sigmoidal Mode of Cumulative Distribution Function

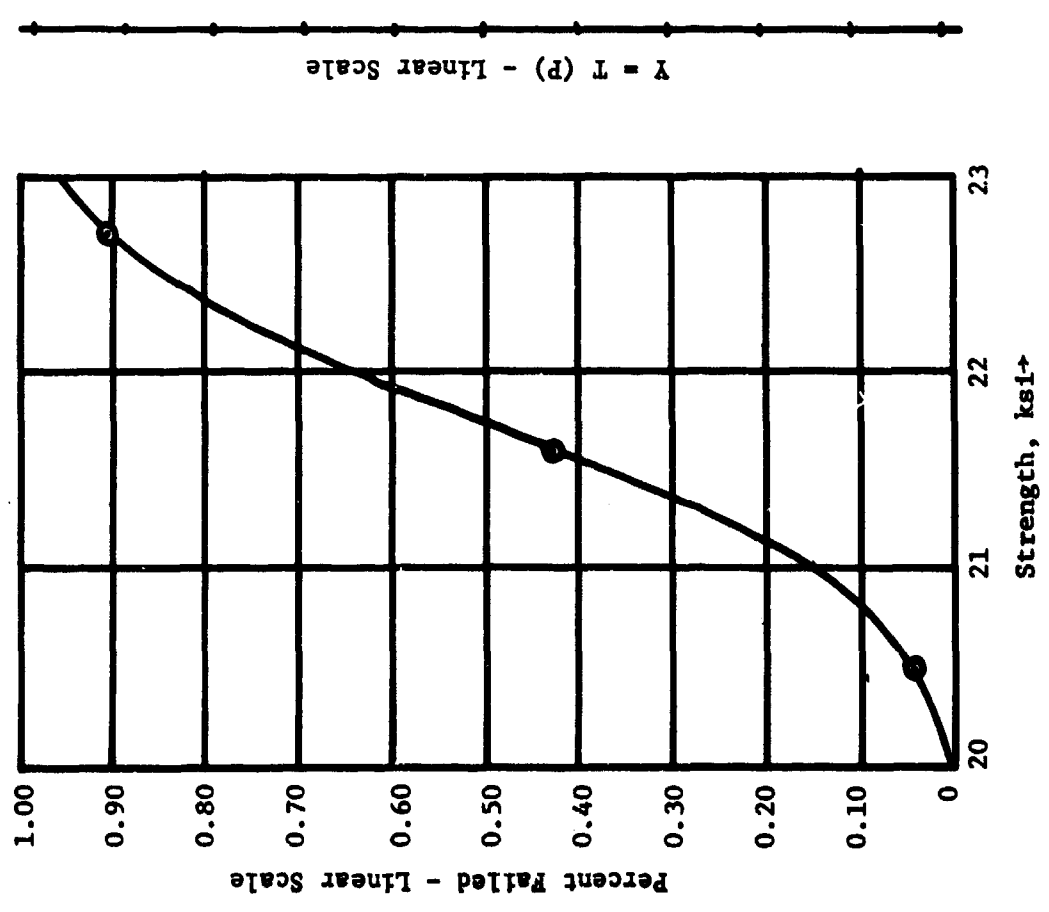

Figure 6.6 Straight Line Mode of Cumulative Distribution Function

Either or both the abscissa scale and the ordinate scale may be transformed for linearizing the frequency distribution functions. In the following section the linearizing transformation equations are derived.

#### 6.4.1 Weibull Distribution

The general expression for the Weibull cumulative distribution function, Equation 6.13, is:

$$p = 1 - e^{-\left(\frac{x-X_0}{\theta-X_0}\right)^b} \quad X_0 \leq x \leq \infty$$

with original variables

P = probability of failure

x = strength

or,

$$\frac{1}{1-p} = e^{\left(\frac{x-X_0}{\theta-X_0}\right)^b}$$

$$\ln \ln \left(\frac{1}{1-p}\right) = b \ln (x-X_0) - b \ln (\theta-X_0) \quad (6.23)$$

This has a form of  $Y = \beta X + \alpha$  where:

$$Y = \ln \ln \frac{1}{1-p} \quad (6.24)$$

$$X = \ln (x-X_0) \quad (6.25)$$

$$\beta = b \quad (6.26)$$

$$\alpha = -b \ln (\theta-X_0) \quad (6.27)$$

The Equations (6.24) and (6.25) respectively for ordinate and abscissa scales, are the linearizing transformation equations for Weibull distribution. Hence, if the new scales (ordinate and abscissa) are constructed corresponding to these equations, the points following Weibull distribution should plot as a straight line on these new scales.

#### 6.4.2 Normal Distribution

In the case of Weibull distribution, the density function (Equation 6.12) can be integrated in the closed form to give the cumulative distribution function (Equation 6.13),

$$P(x) = 1 - e^{-\left(\frac{x-X_0}{\theta-X_0}\right)^b}$$

whereas in the case of Normal distribution, it is not possible to integrate the density function in the closed form to give Normal cumulative distribution function. Hence, this is expressed as:

$$P(x) = \int_{-\infty}^{+\infty} \frac{1}{\sqrt{2\pi}\sigma} e^{-\frac{(x-\mu)^2}{2\sigma^2}} dx$$

Whereas, in the case of Weibull distribution, the Equation 6.13 can be transformed into a straight line function (See Equation 6.23), there is no simple transformation for the case of Normal distribution that can be used to relate the original variable  $P(x)$  to a linear mode variable, which is  $\ln \ln \frac{1}{1-P(x)}$  in the case of Weibull. Hence, the following method was used to linearize the Normal distribution.

The general equation of the linear form (straight line) of a distribution is:

$$Y = \alpha + \beta X \quad (6.28)$$

where  $X$  is some function of strength  $x$  [for example,  $X = \ln(x - X_0)$  for Weibull] and  $Y$  is some function of probability  $P$  (for example,  $Y = \ln \ln \frac{1}{1-P}$ ). Since  $Y$  is not a simple function of probability ( $P$ ), one needs to find a new variable which should satisfy the Equation (6.28), and it should be related to  $P$  in such a manner that it can be used to find necessary values of this new variable for any given corresponding value of  $P$ .

Such a variable can be the standardized normal variate,  $z$ . The standardized normal variate,  $z$ ;

1. is related to  $P$  values and could be found directly from the Tables of Normal distribution, such as given in Section 2, Table 2.1.
2. satisfies the Equation (6.28). This is shown below:

$z$  is expressed as:

$$z = \frac{x - \mu}{\sigma}$$

or 
$$z = \left(\frac{1}{\sigma}\right) X - \left(\frac{\mu}{\sigma}\right)$$

This has the same form as Equation (6.28), where

$$Y = z, \quad \frac{1}{\sigma} = \beta, \quad \frac{\mu}{\sigma} = \alpha, \quad \text{and } x = \text{strength.}$$

Hence, the linearizing transformation equations for Normal distribution are:

$$Y = z, \text{ the Standardized Normal Variate} \quad (6.29)$$

$$X = x \quad (6.30)$$

If the transformation just described does linearize the Normal distribution function, it will plot as a straight line on a Cartesian paper. A graphical example demonstrating the linearization of Normal distribution is shown:

The Normal distribution function with a mean of  $\mu = 28$  and  $\sigma = 4.25$  was plotted on a Normal probability paper (See Figure 6.7) from which the following values of  $x$  and its corresponding values of  $P$  were selected:

<u>x</u>	<u>P</u>
15	.0015
20	.035
25	.25
35	.95

For the corresponding values of  $P$ , the values of  $z$  were found from the Tables of Normal distribution:<sup>(9)</sup>

<u>x</u>	<u>P</u>	<u>T(P) = z = <math>\frac{x-\mu}{\sigma}</math></u>
15	.0015	2.97
20	.035	1.82
25	.025	0.67
35	.95	-1.65

The values of  $x$  on the abscissa and  $z$  on the ordinate were plotted on a Cartesian coordinate paper, and the resultant plot was found to be a straight line (See Figure 6.8). Hence, this proved that this method did linearize the Normal distribution and the linearizing transformation equations are Equations (6.29) and (6.30);

$$Y = z$$

$$\text{and } X = x .$$

#### 6.4.3 Extreme Value Distributions

The general expression for the cumulative distribution function of the Largest Extreme Value distribution is, from Equation 6.20):

$$P = e^{-e^{-\beta(x-M)}}$$

By taking the  $\ln$  twice, this equation reduces to a form of a straight line:

$$-\ln \ln \left( \frac{1}{P} \right) = \beta x - \beta M \quad (6.31)$$

or  $Y = \beta x + \alpha$

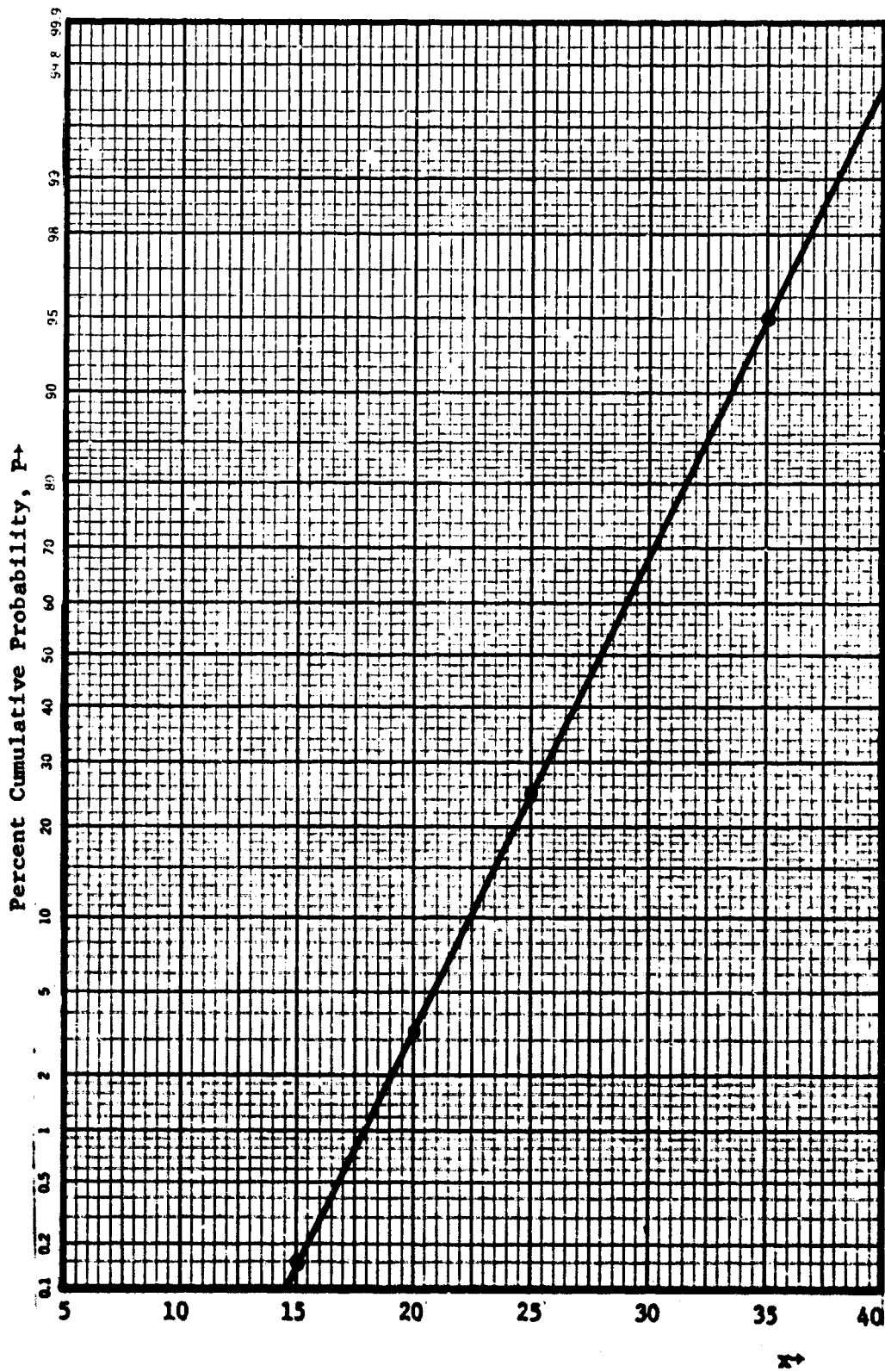

Figure 6.7 Plot of x vs. P on Normal Probability Paper



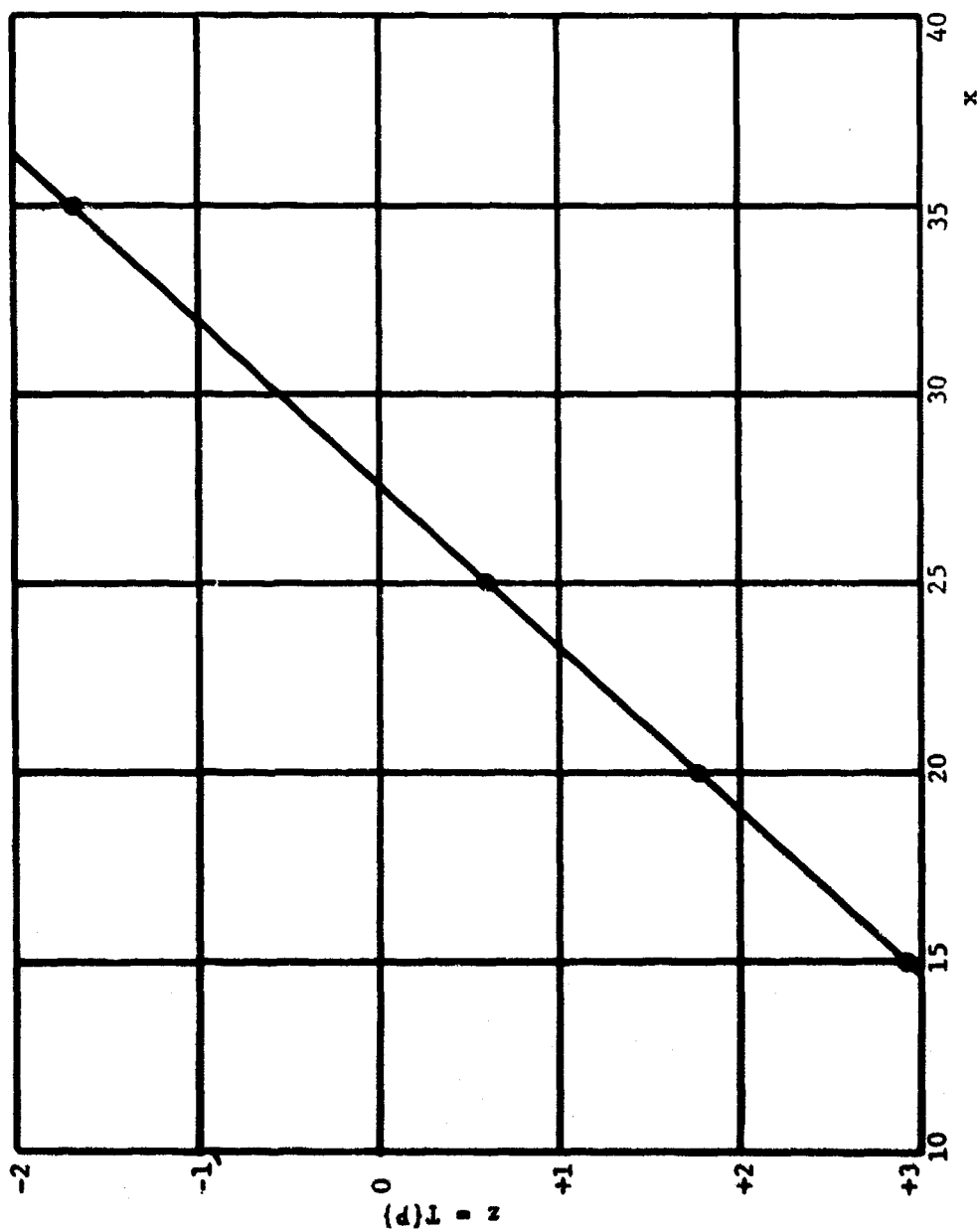

Figure 6.8 Plot of x vs. z on Cartesian Paper

$$\text{where } Y = -\ln \ln \left( \frac{1}{P} \right) \quad (6.32)$$

$$X = x \quad (6.33)$$

$$\alpha = -\beta M \quad (6.34)$$

Equations (6.32) and (6.33) are linearizing transformation equations for Largest Extreme Value distributions. For Smallest Extreme Value distributions, the linearizing transformation Equations (6.35) and (6.36) were found in a similar manner. They are:

$$Y = \ln \ln \frac{1}{1-P} \quad (6.35)$$

$$X = x \quad (6.36)$$

$$\alpha = -\beta M \quad (6.37)$$

## 6.5 FITTING THE LINEARIZED DISTRIBUTION TO THE STRENGTH DATA

In the previous sections, the parameters, the linearizing transformation equations, and the linear mode variables of the distribution functions used in this study were presented. The best fitting distribution is the one which has the highest correlation coefficient,  $R$ . In order to determine the values of  $R$  for each distribution, they should be fitted to Probability-Strength ( $P, x$ ) data by fitting a least squares line ( $Y = \alpha + \beta X$ ) to the linear mode variables of these data. This was done for all the distributions in the following manner:

### 6.5.1 Weibull Distribution

The original variables of the data are Probability and Strength ( $P$  and  $x$ ). From the linearizing transformation Equations (6.24) and (6.25);

$$Y = \ln \ln \frac{1}{1-P}$$

and  $X = \ln(x - X_0)$ , the linear mode variables are  $\ln \ln \frac{1}{1-P}$  and  $\ln(x - X_0)$ , where  $x$  is the original variable (strength),  $P$  is the cumulative probability from the median rank table,  $X_0$  is the lower bound of strength, and  $X$  and  $Y$  are the linear mode variables.

By substitution of  $X$  and  $Y$  in Equations (6.2) and (6.3), the values of the parameters  $\alpha$  and  $\beta$  for the least squares line ( $Y = \alpha + \beta X$ ) were computed:

$$\beta = \frac{n \left[ \sum_{i=1}^n \left( \ln \ln \frac{1}{1-P_i} \right) \ln(x_i - X_0) \right] - \sum_{i=1}^n \ln(x_i - X_0) \sum_{i=1}^n \left( \ln \ln \frac{1}{1-P_i} \right)}{n \sum_{i=1}^n [\ln(x_i - X_0)]^2 - \left[ \sum_{i=1}^n \ln(x_i - X_0) \right]^2} \quad (6.38)$$

$$\text{and } \alpha = \frac{\sum_{i=1}^n (\ln \ln \frac{1}{1-P_i}) - \beta \sum_{i=1}^n \ln (x_i - X_0)}{n} \quad (6.39)$$

In order to compute  $\alpha$  and  $\beta$  it was first necessary to determine  $X_0$  from the Probability-Strength ( $P, x$ ) data. Once the  $X_0$  was determined, the values of  $\alpha$  and  $\beta$  were computed, and the correlation coefficient  $R$  was found by substituting the values of  $\alpha$  and  $\beta$  in Equation 6.6. In the past investigation<sup>(1)</sup>,  $X_0$  was determined by a graphical method; in the present investigation this was done by a computer approach, as follows:

1. A value for  $X_0$  was assumed which should be somewhere between zero and the lowest strength value of the test data. Let this  $X_0$  be  $X_0(1)$ .
2. Once the value of  $X_0$  is known or assumed, the original variables of the data points can be transformed to the linear mode variables by using the transformation equations

$$Y = \ln \ln \frac{1}{1-P}$$

$$X = \ln (x - X_0).$$

3. By substitution of each value of  $X$  and  $Y$  corresponding to each value of the original data points ( $P, x$ ) in Equations (6.2) and (6.3), the parameters  $\alpha$  and  $\beta$  of the least squares line  $Y = \alpha + \beta X$  were then computed.
4. Using the values of  $\alpha$  and  $\beta$ , the value of correlation coefficient  $R$  for this fit was computed from Equation (6.6). Let this correlation coefficient be  $R(1)$ .
5. Another  $X_0$  was then assumed close to (greater or less than)  $X_0(1)$ . Let this be  $X_0(2)$ . The steps 1 through 4 were repeated. Let the correlation coefficient thus computed be  $R(2)$ .
6. The next value of  $X_0 = X_0(3)$  was then computed in the following manner: (See Figure (6.9))  
Whenever the ratio  $\frac{\Delta R}{\Delta X_0} = \frac{R(2) - R(1)}{X_0(2) - X_0(1)}$  is positive, the value of  $X_0(3)$  was assumed to be larger than  $X_0(2)$ ; and if the ratio is negative, the value of  $X_0(3)$  was assumed to be smaller than  $X_0(2)$ . The larger the standard deviation of the strength data, the larger will be the difference  $[X_0(3) - X_0(2)]$  that can be assumed.
7. After  $X_0(3)$  was found, the steps 2, 3, and 4 were repeated; the corresponding value of correlation coefficient  $R(3)$  was computed.
8. This was repeated twelve times, and twelve  $X_0$ 's and their corresponding values of  $R$  were computed. (Note: The number of repetitions, twelve, was selected arbitrarily).

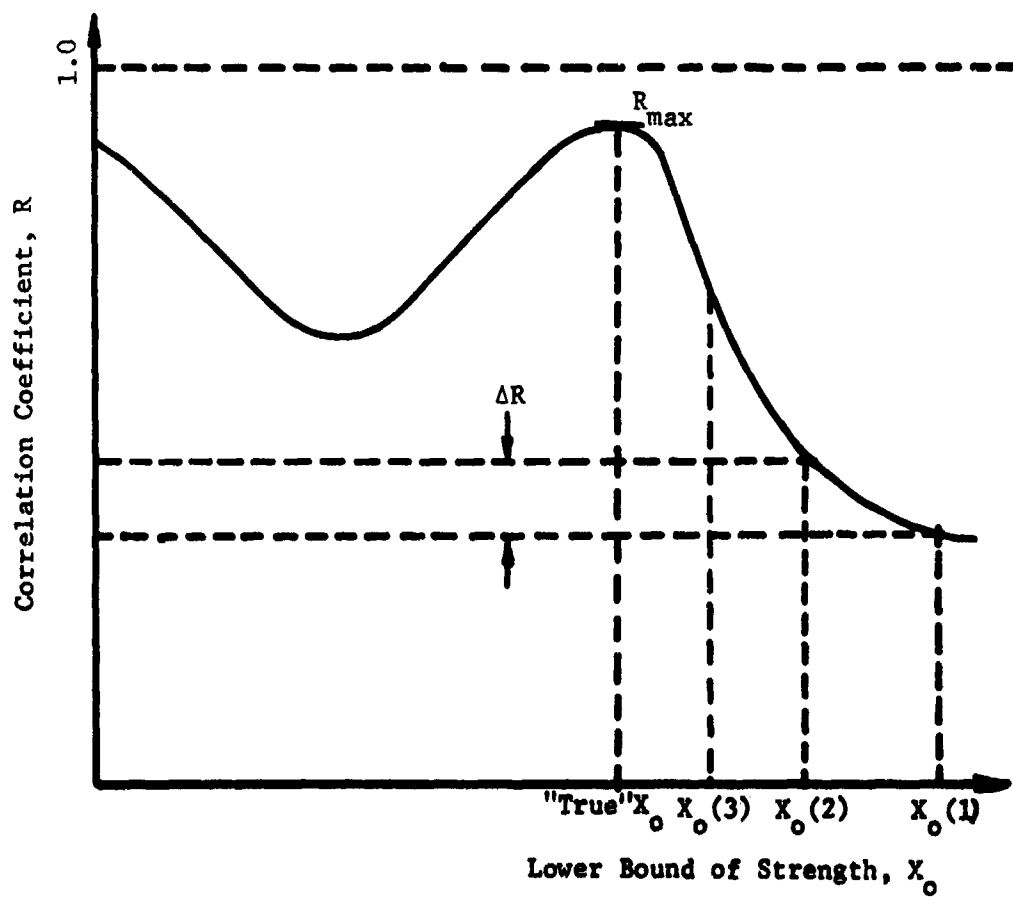

Figure 6.9 Determination of  $X_o$  by Trial and Error Method

Out of these 12 lower bound  $X_0$ 's, the one which gave the maximum correlation coefficient (R) (the best fit) was taken as the "true" lower bound of strength  $X_0$ . Once the true value of  $X_0$  was determined, this and the values of  $x$  and  $P$  were substituted in Equations (6.38) and (6.39) to compute  $\alpha$  and  $\beta$ ; and, subsequently, the correlation coefficient R was determined from Equation (6.6).

### 6.5.2 Normal Distribution

To fit a Normal distribution to a set of data means fitting a straight line (least squares line  $Y = \alpha + \beta X$ ) such that:

$$Y = z, \text{ the standardized Normal variate}$$

$$\text{and } X = x, \text{ the fatigue strength.}$$

The values of  $z$  correspond to the values of median ranks, and they were found from the Normal Distribution Table.<sup>(9)</sup>

For example, if the total number of test points is three, their corresponding values of median ranks are (2): .2063, .5000 and .7937 as read from the median ranks table. These values represent the areas under the Normal distribution curve (See Figure 6.10). Hence, the values of  $z$  corresponding to the values of the median ranks, .2063, .5000, and .7937 are  $-.8194$ ,  $0$ , and  $+.8194$  as read from the Normal Distribution Table. The values of  $z$  or median rank  $z$  values were found in the similar manner for various values of median ranks. The table of median rank  $z$  values similar to the table of median ranks was constructed, see Table 6.1. These tables of median ranks and median rank  $z$  values, which are in matrix form, were stored into the computer for the purpose of the data analysis. The values of  $X = x$  (fatigue strength) and  $Y = z$  (the corresponding value of the standardized Normal variate) were substituted in Equations 6.2 and 6.3, and  $\alpha$  and  $\beta$  were computed to give the equation of the least square line,  $Y = \alpha + \beta X$ , fitted through these points.

The next step was then to determine the correlation coefficient R. This was done using the Equation 6.6.

Since the Normal distribution is a little more involved than the other distributions (Weibull and Extreme Value), an example is given to illustrate the procedure of fitting the Normal distribution to data.

Suppose the fatigue strength distribution data at  $10^5$  life cycles are: 27.0, 24.0, 32.5, and 29.0 ksi. (Although the number of test points were at least 10 or more in our study, four test points are given to make the correlation simple.)

The data were then arranged in an increasing order of value and the appropriate median ranks  $z$  values for sample size  $n = 4$  were read from Table 6.1 as follows.

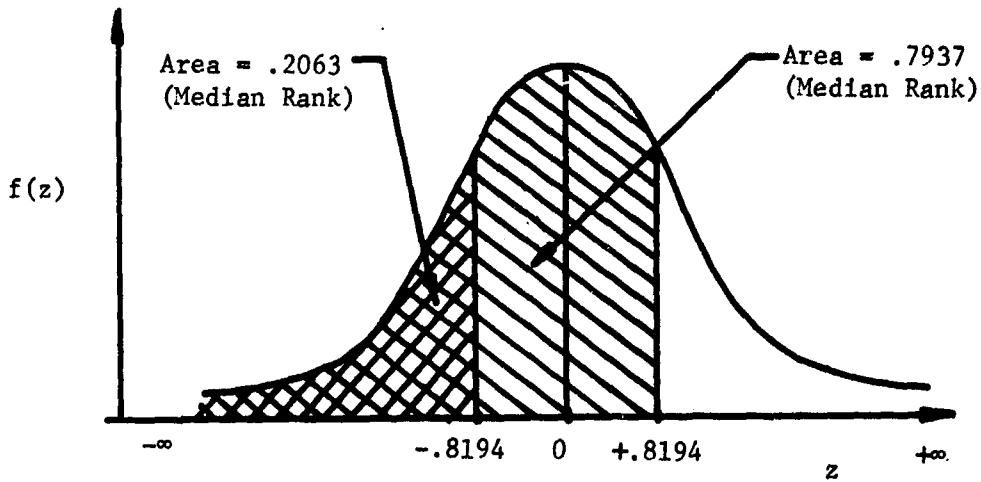

Figure 6.10 Illustration for the Median Rank z Values

MEDIAN RANKS z VALUES

Order Number, j	Sample Size, n				
	1	2	3	4	5 . . . . . 40
1	0.0000	-0.5450	-0.8194	-0.9982	-1.1290
2		+0.5450	0.0000	-0.2887	-0.4826
3			+0.8194	+0.2887	0.0000
4				+0.9982	+0.4826
5					+1.1290
.					
.					
.					
.					
40					

Table 6.2 Median Ranks z Values

<u>x, ksi</u>	<u>Median Ranks z Values</u>
24.0	-0.9982
27.0	-0.2887
29.0	+0.2887
32.5	+0.9982

By substitution of  $X = x$  and  $Y = z$  values in Equations (6.2) and (6.3), they reduced to:

$$\beta = \frac{n \sum_{i=1}^n z_i x_i - \sum_{i=1}^n x_i \sum_{i=1}^n z_i}{n \sum_{i=1}^n x_i^2 - \left( \sum_{i=1}^n x_i \right)^2}$$

$$\text{and } \alpha = \frac{\sum_{i=1}^n z_i - \beta \sum_{i=1}^n x_i}{n}$$

The values of  $\alpha$  and  $\beta$  were then computed to determine the equation of the least squares line,  $Y = \alpha + \beta X$ . Knowing the value of  $\beta$ , the correlation coefficient  $R$  was determined from Equation 6.6:

$$R = (\beta)^2 \frac{S_x^2}{S_y^2} = (\beta)^2 \frac{S_x^2}{S_z^2}$$

$$\text{where } S_x^2 = \frac{n \sum_{i=1}^n x_i^2 - \left( \sum_{i=1}^n x_i \right)^2}{n(n-1)} \quad \begin{array}{l} \text{Sample Variance} \\ \text{of } x \\ \text{(abscissa)} \end{array}$$

$$\text{and } S_y^2 = \frac{n \sum_{i=1}^n z_i^2 - \left( \sum_{i=1}^n z_i \right)^2}{n(n-1)} \quad \begin{array}{l} \text{Sample Variance} \\ \text{of } z \\ \text{(ordinate)} \end{array}$$

### 6.5.3 Extreme Value Distributions

The linearizing transformation equations for Largest Extreme Value distribution (Equations 6.35 and 6.36) are:

$$Y = -\ln \ln \left( \frac{1}{p} \right)$$

$$\text{and } X = x$$

By substitution of  $X$  and  $Y$  in Equations (6.2) and (6.3), the values of the parameters  $\alpha$  and  $\beta$  for the least square line ( $Y = \alpha + \beta X$ ) were computed:

$$\beta = \frac{n \left[ \sum_{i=1}^n \left( -\ln \ln \frac{1}{P_i} \right) (x_i) \right] - \sum_{i=1}^n (x_i) \sum_{i=1}^n \left( -\ln \ln \frac{1}{P_i} \right)}{n \sum_{i=1}^n (x_i)^2 - \left( \sum_{i=1}^n x_i \right)^2} \quad (6.40)$$

$$\text{and } \alpha = \frac{\sum_{i=1}^n \left( -\ln \ln \frac{1}{P_i} \right) - \beta \sum_{i=1}^n (x_i)}{n} \quad (6.41)$$

Knowing the value of  $\beta$ , the correlation coefficient  $R$  was determined from Equation (6.6).

$$R = (\beta)^2 \frac{S_x^2}{S_y^2}$$

$$\text{where } S_x^2 = \frac{n \sum_{i=1}^n x_i^2 - \left( \sum_{i=1}^n x_i \right)^2}{n(n-1)} \quad \begin{array}{l} \text{Sample Variance} \\ \text{of } x \\ \text{(abscissa)} \end{array} \quad (6.42)$$

$$\text{and } S_y^2 = \frac{n \sum_{i=1}^n \left( -\ln \ln \frac{1}{P_i} \right)^2 - \left[ \sum_{i=1}^n \left( -\ln \ln \frac{1}{P_i} \right) \right]^2}{n(n-1)} \quad \begin{array}{l} \text{Sample Variance} \\ \text{of } y \\ \text{(ordinate)} \end{array} \quad (6.43)$$

$$\text{where } y = -\ln \ln \frac{1}{P}$$

In a similar manner, Smallest Extreme Value distribution was fitted to the data such that:

$$Y = \ln \ln \frac{1}{1-F}$$

$$\text{and } X = x.$$

The values of  $\alpha$  and  $\beta$  were computed using Equations (6.2) and (6.3) and the correlation coefficient  $R$  using Equation (6.6).

## 6.6 DETERMINATION OF THE BEST FITTING DISTRIBUTION AND ITS PARAMETERS

In the previous sections, the statistical distributions, their parameters, and their linearizing transformation equations were discussed. The distributions were then fitted to the data by fitting a least squares line ( $Y = \alpha + \beta X$ ) to the linear mode variables of these data by computing the values of  $\alpha$  and  $\beta$  from Equations (6.2) and (6.3). Knowing  $\alpha$  and  $\beta$ , the



the correlation coefficients  $R$  were determined from Equation (6.6). The best fit distribution was the one which had the largest value of correlation coefficient  $R$ . This distribution could be taken as the "true" representation of the scatter of the strength data. The linear mode of the distributions [for example,  $\ln(x-X_0)$  and  $(\ln \ln \frac{1}{1-F})$  for Weibull] are not used in practice, and therefore, the original parameters ( $b$ ,  $X_0$ , and  $\theta$  for Weibull) of the distribution should be computed. These parameters were determined from the slope  $\beta$  and the interception  $\alpha$  of the fitted least squares line. This could be done by using the inverse-transformation equation as mentioned in Section 6.4. The specific inverse-transformation equations to compute the parameters of the four distributions used in this study are given in the following sections.

### 6.6.1 Weibull Distribution

As mentioned before, Weibull distribution has three parameters. They are:

- $X_0$  = lower bound of strength
- $b$  = the slope
- $\theta$  = characteristic strength

The method of determining the value of  $X_0$  was explained in Section 6.5.1.  $b$  is also the slope of the least squares line whose parameters are  $\alpha$  and  $\beta$ . Therefore,  $b = \beta$ .  $\theta$  was determined from Equation 6.27:

$$\alpha = -b \ln (\theta - X_0)$$

$$\ln (\theta - X_0) = -\frac{\alpha}{b}$$

$$\text{Therefore, } \theta = e^{\frac{\alpha}{b}} + X_0 \quad (6.44)$$

$$\text{and } b = \beta \quad (6.45)$$

### 6.6.2 Normal Distribution

The Normal distribution has only two parameters. They are:

- $\mu$  = mean
- $\sigma$  = standard deviation

The linear form of the distribution is expressed as

$$z = \frac{1}{\sigma} X - \frac{\mu}{\sigma}$$

and the equation of the least squares line is :

$$Y = SX + \alpha$$

Hence, the parameters of this line are:

$$\alpha = -\frac{\mu}{\sigma}; \quad \beta = \frac{1}{\sigma}$$

$\sigma$  and  $\mu$  were computed from rearranging these equations:

$$\sigma = \frac{1}{\beta} \quad (6.46)$$

$$\mu = -\sigma\alpha = -\frac{\alpha}{\beta} \quad (6.47)$$

### 6.6.3 Extreme Value Distributions

Both of these distributions have two parameters, and they are referred to as extremal parameters. However, in this study, these parameters are referred to as:

$b$  = slope

$M$  = Mode

The slope  $b$  is the slope of the least squares line (as it was the case for Weibull distribution). Hence,  $b = \beta$ .

The mode  $M$  was determined from Equation 6.34:

$$M = -\frac{\alpha}{\beta} \quad (6.48)$$

$$\text{and } b = \beta \quad (6.49)$$

These equations would apply to determine the parameters ( $M, \beta$ ) for both Largest and Smallest Extreme Value distributions even though the numerical values of  $\alpha$  and  $\beta$  would be different in each case.

Using the statistical and analytical tools discussed here, a computer program was developed whereby the computer prints out the fatigue strength distribution functions, their parameters, and the corresponding degree of fit (correlation coefficient  $R$ ) for several preassigned lives.

Data on various non-ferrous materials under various conditions were collected and analyzed by computer-aided procedure as described above. The results are tabulated in Appendix 1 in terms of the best fitting distribution function and its parameters for several lives. The most representative parameters were then plotted, as shown in Figures 6.14 to 6.64. The discussion as related to these plots is given in Section 6.7.

## 6.7 GRAPHS OF THE FATIGUE STRENGTH DISTRIBUTION PARAMETERS

### 6.7.1 Expression of Data in Terms of Normal Parameters

By aid of the computer approach discussed in Section 6, the fatigue strength data were analyzed where different distributions (Weibull, Normal, Largest Extreme Value, and Smallest Extreme Value) were fitted to a set of data. The computer printed out the parameters and the degree of fit (correlation coefficient  $R$ ) for each of these distributions for a given set of data.

This was done for various materials under various conditions. A representative computer output sheet for a material and conditions shown below is given in Table 6.2.

Material:	.7075 Aluminum (Bar), $S_u = 86$ ksi
Life:	$10^5$ cycles
Type of Loading:	Rotary Beam Bending
Theoretical Stress Concentration Factor:	$K_t = 2.0$
Other Conditions:	See Page 233 and Code Number (240)

The distribution with maximum value of correlation coefficient  $R$  was considered to be the best fitting distribution. For example, for the data given in Table 6.2, the maximum value of  $R$  is 0.948724, and this corresponds to Largest Extreme Value distribution. Hence, Largest Extreme Value distribution is the best fitting distribution of the fatigue strength of the above material under the given conditions. Its parameters are:

$$\text{BETA } (\beta) = .301634$$

$$\text{and MODE } (M) = 35.155$$

The fatigue strength data of various non-ferrous materials under various conditions (effects) were analyzed in a similar manner. The results were tabulated in terms of only the best fitting distribution (this could be Largest Extreme Value, Smallest Extreme Value, Weibull, or Normal) and its parameters according to the materials in Appendix 1. The tabulated values were rounded to four digits. It was felt that the representative parameters should be plotted to study the effects of such factors as stress concentration, surface finish, type of loading, etc. on the distribution of the fatigue strength. This may lead to confusion as illustrated by the following example. Say, for a given material and conditions, the Weibull parameters are  $X_0$ ,  $\theta$ , and  $b$  with  $K_t = 2.4$ . However, for the same material and conditions, if the design should be changed so that  $K_t$  becomes 1.5, the distribution function may change from Weibull to Smallest Extreme Value (with parameters  $\beta$  and  $M$ ); and if  $K_t$  should become 1.0, it may change to Normal (with parameters  $\mu$  and  $\sigma$ ).

When this information is plotted to determine the effect of stress concentration on the distribution parameters, a plot such as in Figure 6.11 results. This obviously cannot make much sense to the reader, as it is very difficult to compare one distribution's parameters (say  $X_0$ ,  $b$ , and  $\theta$ ) for one value of effect (say  $K_t = 2.4$ ) with another distribution's parameters (say  $\beta$  and  $M$ ) for another value of the effect (say  $K_t = 1.5$ ). This problem can be resolved by plotting all the data in terms of the same distribution. This means if, for example, Normal distribution is chosen, then the parameters of the other distributions should be expressed in terms of Normal parameters. This can be done by using, for all the test data, the values of the Normal parameters directly from the computer sheet (a sample is shown in Table 6.2). Al-

\*\*\*\*\*

WEIBULLSMALLEST EXTREME VALUETHETA ( $\theta$ ) = 37.8210BETA ( $\beta$ ) = .301694 $X_d$  = 30.5332

MODE (M) = 38.701

b = 1.9047

R = 0.889976

R = 0.863512

\*\*\*\*\*

LARGEST EXTREME VALUENORMALBETA ( $\beta$ ) = .301634MEAN ( $\mu$ ) = 36.9284

MODE (M) = 35.155

STD. DEVIATION ( $\sigma$ ) = 4.2207

R = 0.948724

R = 0.882308

\*\*\*\*\*

Table 6.2 A Computer Output Data Illustrating the Distribution Parameters and the Corresponding Correlation Coefficients for a Given Set of Data

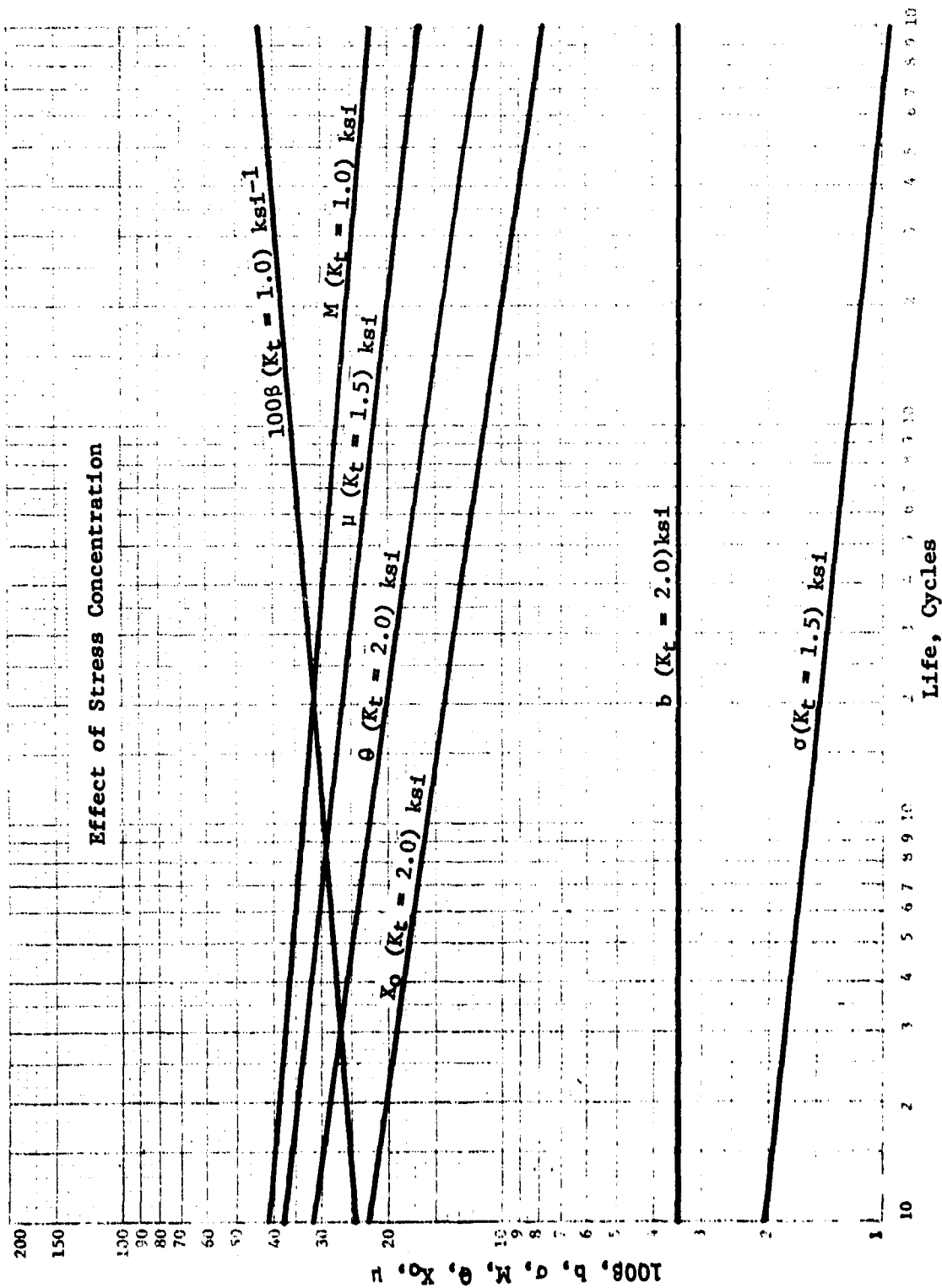

Figure 6.11 Plot of the Actual Distribution Parameters for Various Stress Concentration Factors

though in some cases the best fitting distribution might be other than the Normal distribution, it would not lose the significance by more than 5 to 10%. For example, from Table 6.2, if Normal distribution with  $R = 0.882308$  (that is, 88.2%) is used instead of Largest Extreme Value (the best fitting distribution for this particular case) with  $R = 94.9\%$ , the level of significance of the fit is decreased by only 6.7% ( $94.9 - 88.2 = 6.7\%$ ). Although this approach results in somewhat lower accuracy, it has the advantage of greater clarity.

Out of the four distributions considered in the present investigation, Normal distribution, with parameters  $\mu$  and  $\sigma$ , was selected for making these plots. The reasons for the selection of the Normal distribution are:

1. Normal distribution with its parameters  $\mu$  (mean or average value) and  $\sigma$  (standard deviation or measure of scatter) is easier to understand for engineers with little statistical background.
2. The plot of these two parameters can be represented by a single line for each effect (See Figure 6.12) as compared to, say, Weibull, where three lines (one for each of the three parameters  $X_0$ ,  $b$ , and  $\theta$ ) are needed to represent each effect.
3. Largest or Smallest Extreme Value distribution parameters ( $\beta$  and  $M$ ) are not as easy to understand as in the case of Normal parameters.

It should be noted that: 1) the plots are meant only to represent the effect of different factors on the fatigue strength. For the purpose of solving the actual design problem, it is recommended that the actual distribution and its parameters be used from the tables in Appendix 1; 2) only the representative values from the entire analysis are plotted, whereas the tables in Appendix 1 give all the values.

#### 6.7.2 Explanation of the Graphs

Mean strength  $\mu$  was plotted against life on a log-log paper, one line representing only one effect (see Figure 6.12). To the right of the graph a specific value of  $\sigma/\mu$  accompanies each line, this value being independent of life. Therefore, once  $\mu$  is determined from a graph for a given life and given effect,  $\sigma$  can be calculated from the  $\sigma/\mu$  value.

The meaning of  $\sigma/\mu$  is discussed below:

For any given set of conditions at any given life the values of  $\mu$  and  $\sigma$  were generated by the computer. Consider the illustrative example in Section 6.7.1 graphically shown by the line corresponding to  $K_t = 2.0$  in Figure 6.12.

This is repeated in Figure 6.13. At  $10^5$  cycles, mean strength is  $\mu_1$ . Locate at  $10^5$  cycles ( $\mu_1 + \sigma_1$ ), and through this point draw a line parallel to the original line. (The assumption for drawing parallel lines is justified in Section 6.2, specifically in Figure 6.4.) At  $10^5$  cycles in the example quoted above,  $\sigma = 4.2207$  and  $\mu = 36.9284$ , and, therefore,  $\sigma/\mu = \frac{4.2207}{36.9284} = .1145$ . This in Figure 6.12 corresponds to  $\sigma_1/\mu_1$  at  $10^5$  cycles. At any other life such as  $10^6$ , locate  $\mu_2$  and ( $\sigma_2 + \mu_2$ ). The following demonstrates that

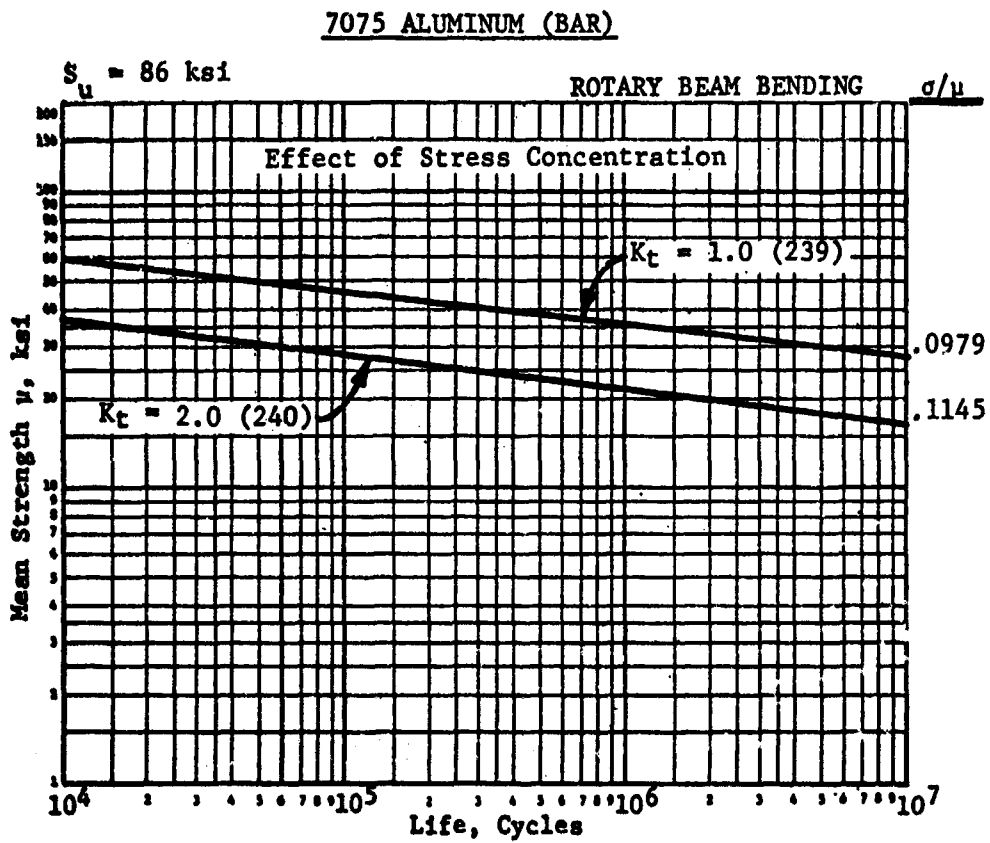

Figure 6.12 Plot of the Normal Parameters

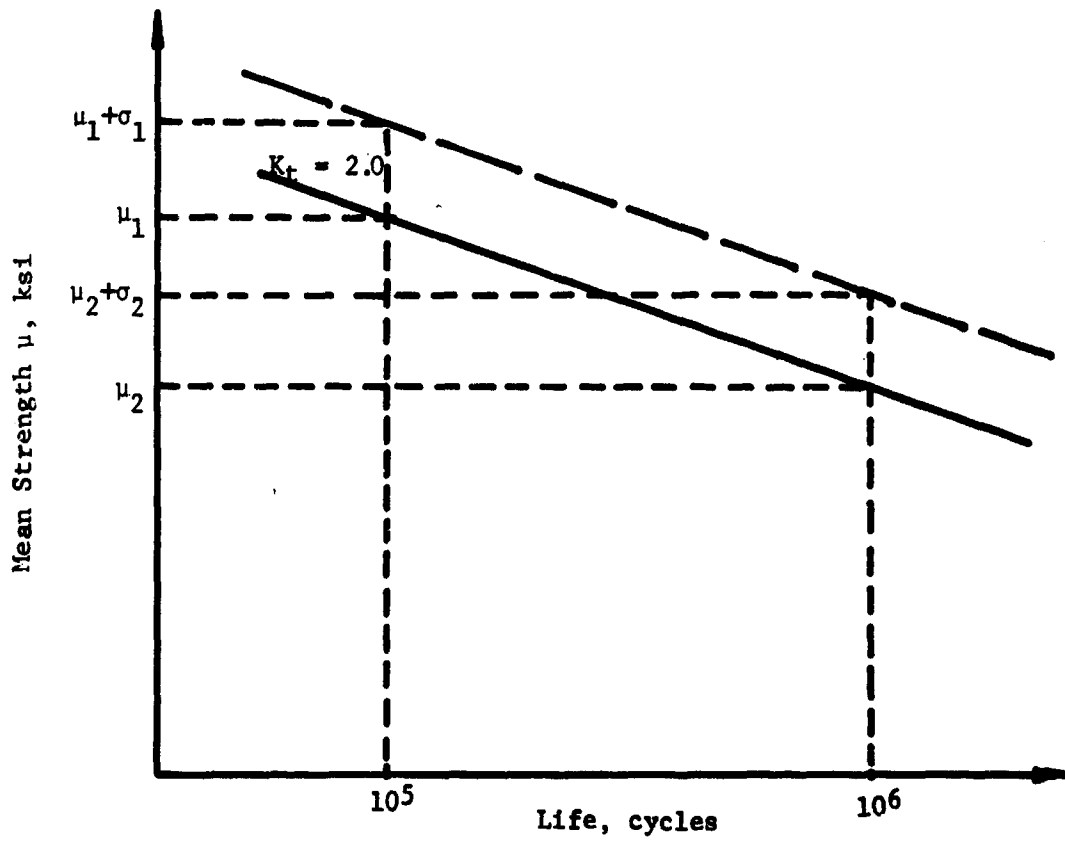

Figure 6.13



$\sigma_2/\mu_2 = \sigma_1/\mu_1 = .1145$  and is thus independent of life. Since the lines are parallel (Figure 6.13),

$$\ln \mu_1 - \ln (\mu_1 - \sigma_1) = \ln \mu_2 - \ln (\mu_2 - \sigma_2)$$

$$\text{or } \ln \frac{\mu_1}{\mu_1 - \sigma_1} = \ln \frac{\mu_2}{\mu_2 - \sigma_2}$$

$$\text{or } \frac{\mu_1}{\mu_1 - \sigma_1} = \frac{\mu_2}{\mu_2 - \sigma_2}$$

or by simple algebra,

$$\frac{\sigma_1}{\mu_1} = \frac{\sigma_2}{\mu_2} = \text{Constant}$$

### 6.7.3 Use of Graphs

In this manner representative data were plotted for various materials and under various conditions. These are shown in Figure 6.14 to Figure 6.64. The use of these graphs can be illustrated by a representative example shown in Figure 6.12. For a life, say,  $10^5$  cycles and  $K_t = 2.0$ , the mean strength  $\mu = 28.0$  ksi and  $\sigma/\mu = 0.1145$ . Therefore,  $\sigma = 0.1145 \times 28 = 3.2$  ksi.

#### 6.7.4 Graphs

INDEX TO GRAPHS OF NORMAL PARAMETERS  
(Effect of Various Factors on Mean and Standard Deviation of Strength)

<u>Material</u>	Normal Parameters can be found:	
	<u>Page No.</u>	<u>Figure No.</u>
<b><u>ALUMINUM ALLOYS</u></b>		
<b>7.5 Zn - 2.5 Mg Aluminum</b>		
Effect of Environment	67	6.14
Effect of Heat Treatment	67	6.14
<b>M-257</b>		
Effect of Stress Concentration	68	6.15
Effect of Test Temperature	68	6.15
<b>M-276</b>		
Effect of Stress Concentration	69	6.16
Effect of Test Temperature	69	6.16
<b>2014 Aluminum</b>		
Effect of Frequency (T-4)	70	6.17
Effect of Frequency (T-6)	70	6.17
Effect of Stress Concentration	71	6.18
Effect of Grain Direction	71	6.18
Effect of Manufacturing Processes	72	6.19
<b>2014 Alclad Aluminum</b>		
Effect of Frequency	73	6.20
<b>2024 Aluminum (Sheets)</b>		
Effect of Specimen Configuration	74	6.21
Effect of Frequency	74	6.21
Effect of Stress Concentration	75	6.22
Effect of Notch Radius	75	6.22
<b>2024 Aluminum (Bars)</b>		
Effect of Stress Concentration (T-4)	76	6.23
Effect of Stress Concentration (T-3)	76	6.23
<b>2024 Aluminum (Extrusions)</b>		
Effect of Manufacturing Processes	77	6.24

	<u>Page No.</u>	<u>Figure No.</u>
2025 Aluminum		
Effect of Heat Treatment	78	6.25
Effect of Surface Finish	78	6.25
Effect of Surface Treatment	79	6.26
Effect of Stress Concentration	79	6.26
2219 Aluminum		
Effect of Heat Treatment	80	6.27
Effect of Stress Concentration	80	6.27
2618 Aluminum		
Effect of Stress Concentration	81	6.28
Effect of Test Temperature	81	6.28
7001 Aluminum		
Effect of Stress Concentration (longitudinal)	82	6.29
Effect of Stress Concentration (transverse)	82	6.29
7075 Aluminum (Sheets)		
Effect of Stress Concentration	83	6.30
Effect of Surface Finish	83	6.30
7075 Aluminum (Bar)		
Effect of Stress Concentration	84	6.31
7075 Aluminum (Extrusions and Forgings)	84	
Effect of Manufacturing Processes	85	6.32
Effect of Stress Concentration	85	6.32
<b><u>COBALT ALLOYS</u></b>		
Stellite-31		
Effect of Stress Concentration	86	6.33
Effect of Test Temperature	86	6.33
<b><u>MAGNESIUM ALLOYS</u></b>		
ZK60A Magnesium		
Effect of Stress Concentration	87	6.34
<b><u>NICKEL ALLOYS</u></b>		
FS-27 Nickel		
Effect of Test Temperature	88	6.35

	<u>Page No.</u>	<u>Figure No.</u>
Hastelloy - R235		
Effect of Test Temperature	89	6.36
Udimet 500		
Effect of Coating	90	6.37
Effect of Test Temperature	90	6.37
6 Mo. Waspalloy		
Effect of Stress Concentration	91	6.38
Effect of Test Temperature	91	6.38
<u>TITANIUM ALLOYS</u>		
Ti-A55		
Effect of Stress Concentration	92	6.39
Ti-75A		
Effect of Surface Finish	93	6.40
Effect of Stress Concentration	93	6.40
Ti-0.2 O <sub>2</sub>		
Effect of Stress Concentration	94	6.41
Ti-.2 C		
Effect of Stress Concentration	95	6.42
Ti-.07 N <sub>2</sub> -.2 O <sub>2</sub> -.2 C		
Effect of Stress Concentration	96	6.43
K-151 A Cermet		
Effect of Test Temperature	97	6.44
K-162 B Cermet		
Effect of Test Temperature	98	6.45
K-183 A Cermet		
Effect of Stress Concentration	99	6.46
Effect of Test Temperature	99	6.46
Ti-4 Al-3 Mo-1V		
Effect of Stress Concentration	100	6.47
Effect of Test Temperature	100	6.47
Ti-5 Al-2.5 Sn-.07 N <sub>2</sub>		
Effect of Stress Concentration	101	6.48
Ti-5 Al-2.5 Sn-.2 O <sub>2</sub>		
Effect of Stress Concentration	102	6.49

	<u>Page No.</u>	<u>Figure No.</u>
Ti-5 Al-2.5 Sn-.2 C		
Effect of Stress Concentration	103	6.50
Ti-5 Al-2.5 Sn-.07 N <sub>2</sub> -.2 C-.2 O <sub>2</sub>		
Effect of Stress Concentration	104	6.51
Ti-6 Al		
Effect of Shot Peening	105	6.52
Effect of Surface Finish	105	6.52
Ti-6 Al-4 V		
Effect of Stress Concentration	106	6.53
Effect of Test Temperature	106	6.53
Ti-6 Al-4 V-.07 N <sub>2</sub>		
Effect of Stress Concentration	107	6.54
Ti-6 Al-4 V-0.2 O <sub>2</sub>		
Effect of Stress Concentration	108	6.55
Ti-6 Al-4 V-0.2 C		
Effect of Stress Concentration	109	6.56
Ti-6 Al-4 V-.07 N <sub>2</sub> -.2 O <sub>2</sub> -.2 C		
Effect of Stress Concentration	110	6.57
Ti-3 Mn-0.2 C <sub>2</sub>		
Effect of Stress Concentration	111	6.58
Ti-3 Mn-.07 N <sub>2</sub>		
Effect of Stress Concentration	112	6.59
Ti-3 Mn-.2 C		
Effect of Stress Concentration	113	6.60
Ti-3 Mn Complex		
Effect of Heat Treatment	114	6.61
Effect of Stress Concentration	114	6.61
Ti-8 Mn		
Effect of Heat Treatment	115	6.62
Effect of Stress Concentration	115	6.62
Ti-13 V-11 Cr-3 Al		
Effect of Heat Treatment	116	6.63
Effect of Stress Concentration	116	6.63

	<u>Page No.</u>	<u>Figure No.</u>
Ti-16 V-2.5 Sn		
Effect of Test Temperature	117	6.64
Effect of Stress Concentration	117	6.64

7.5 Zn - 2.5 Mg ALUMINUM

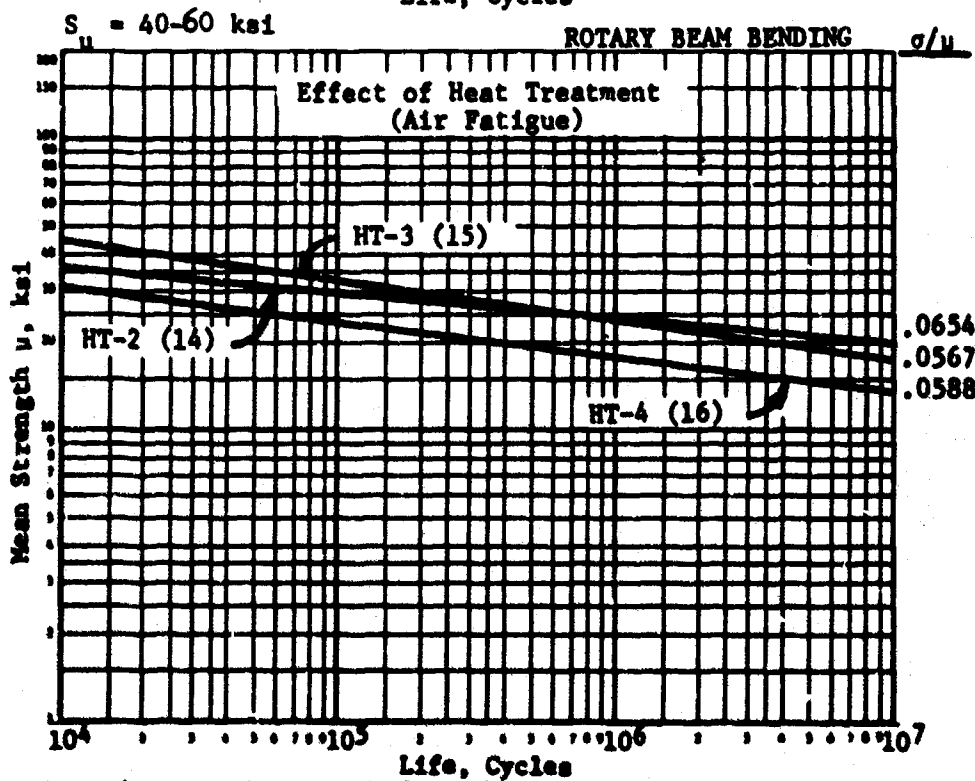
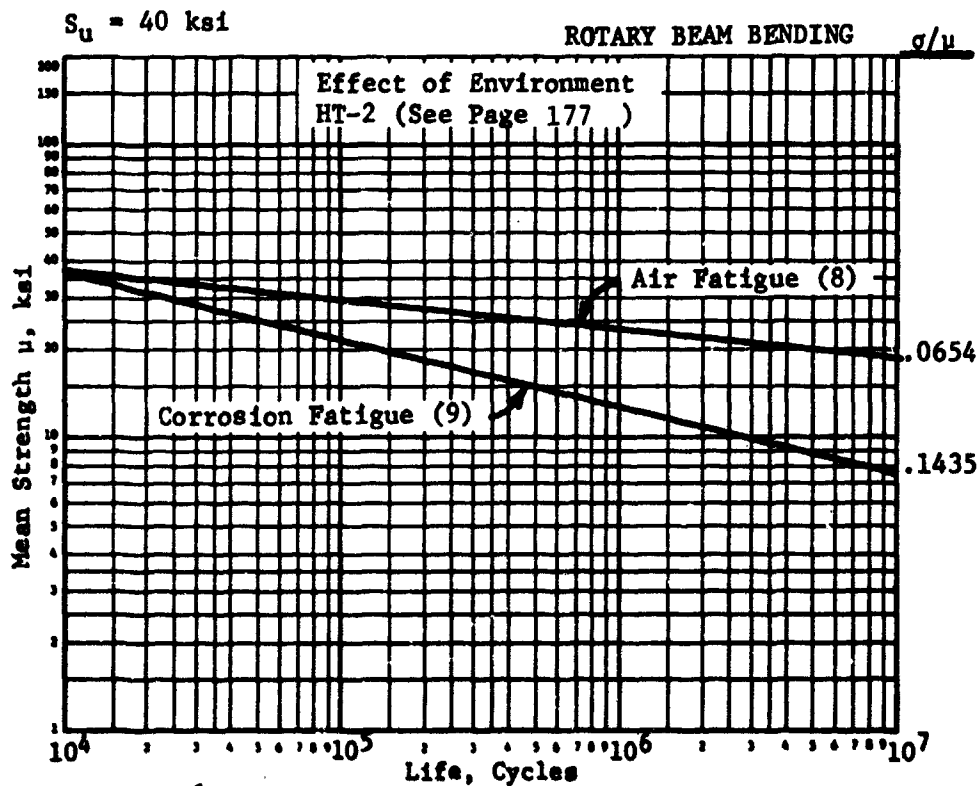

(Numbers in parentheses are the code numbers of the tabulated values.)

Figure 6.14



M-257

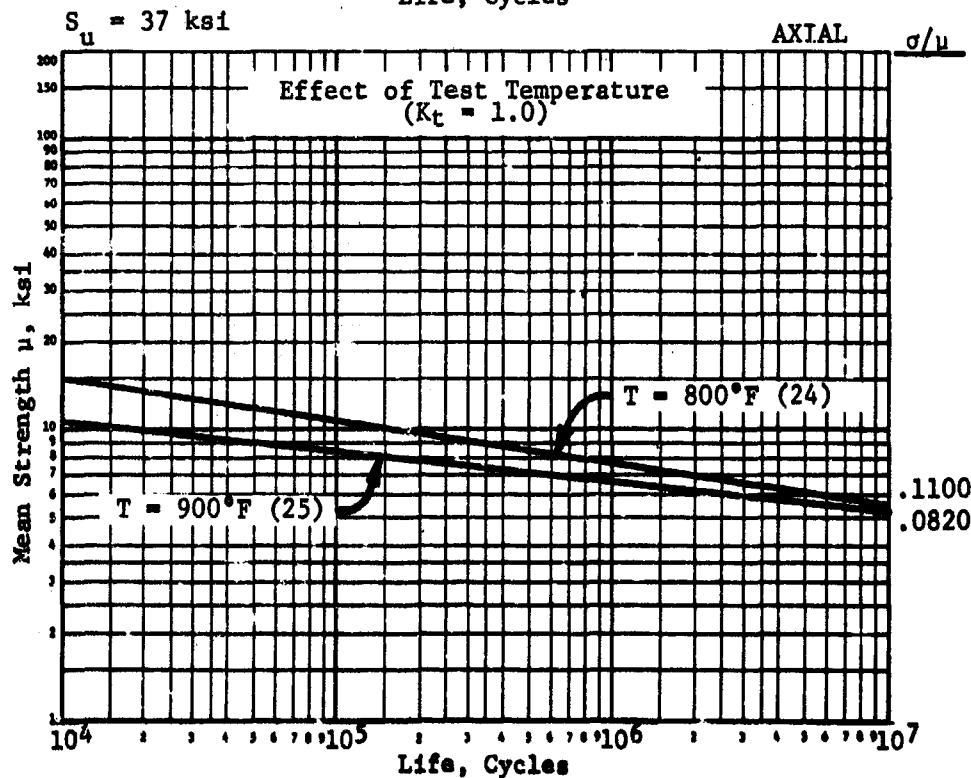
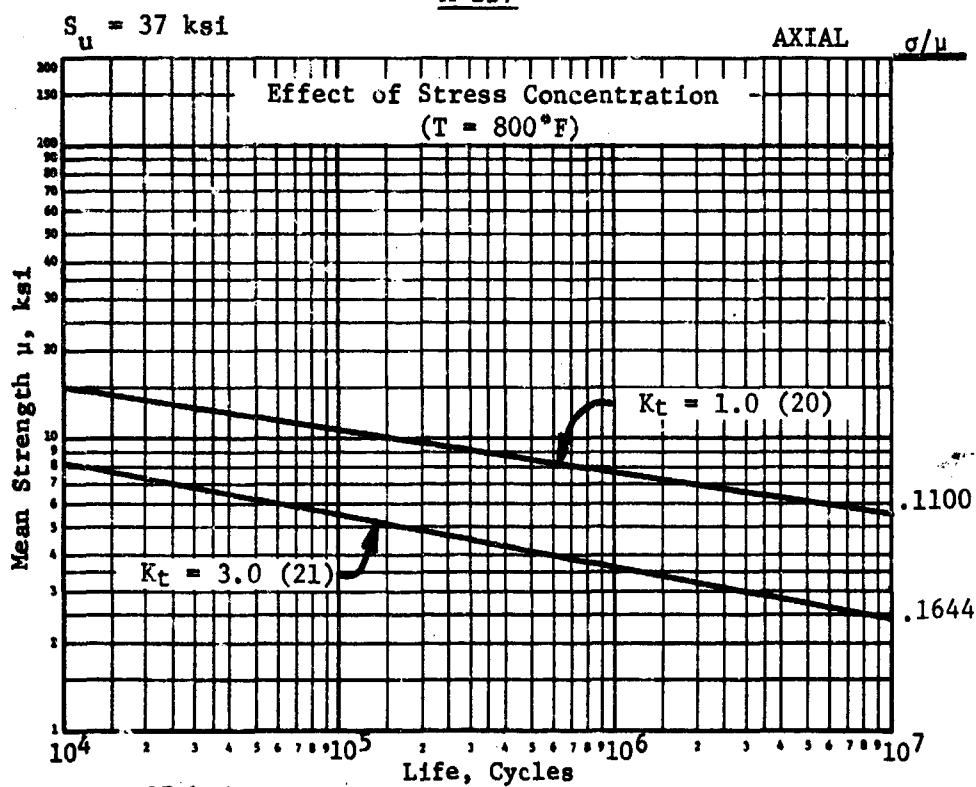

(Numbers in parentheses are the code numbers of the tabulated values.)

Figure 6.15

M-276

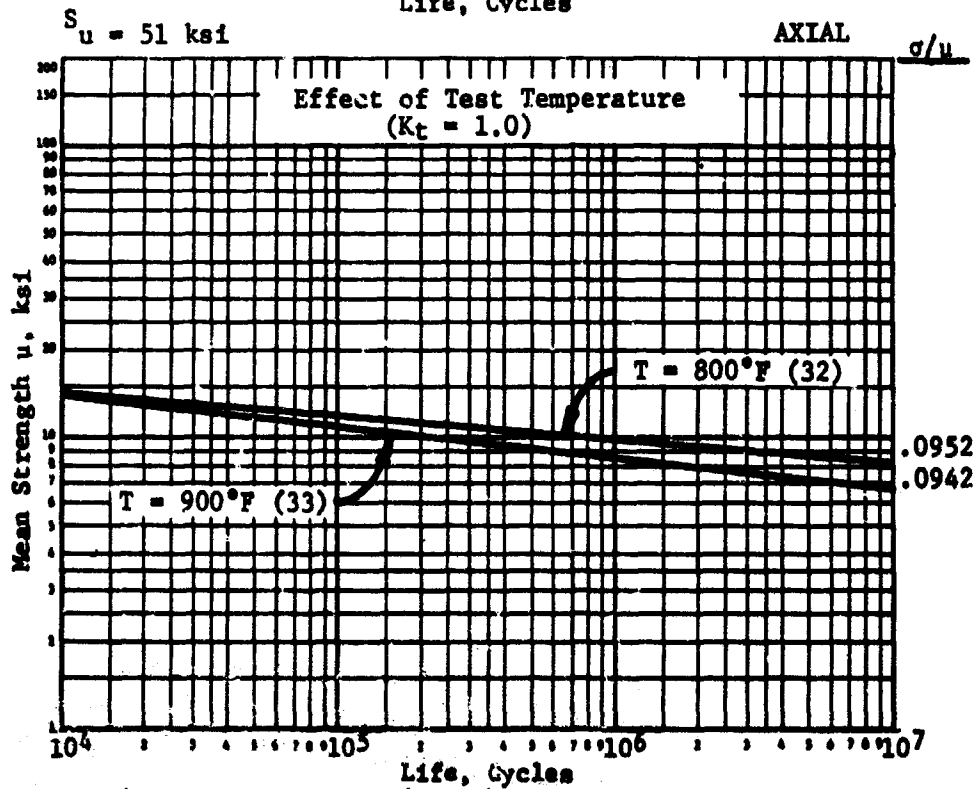
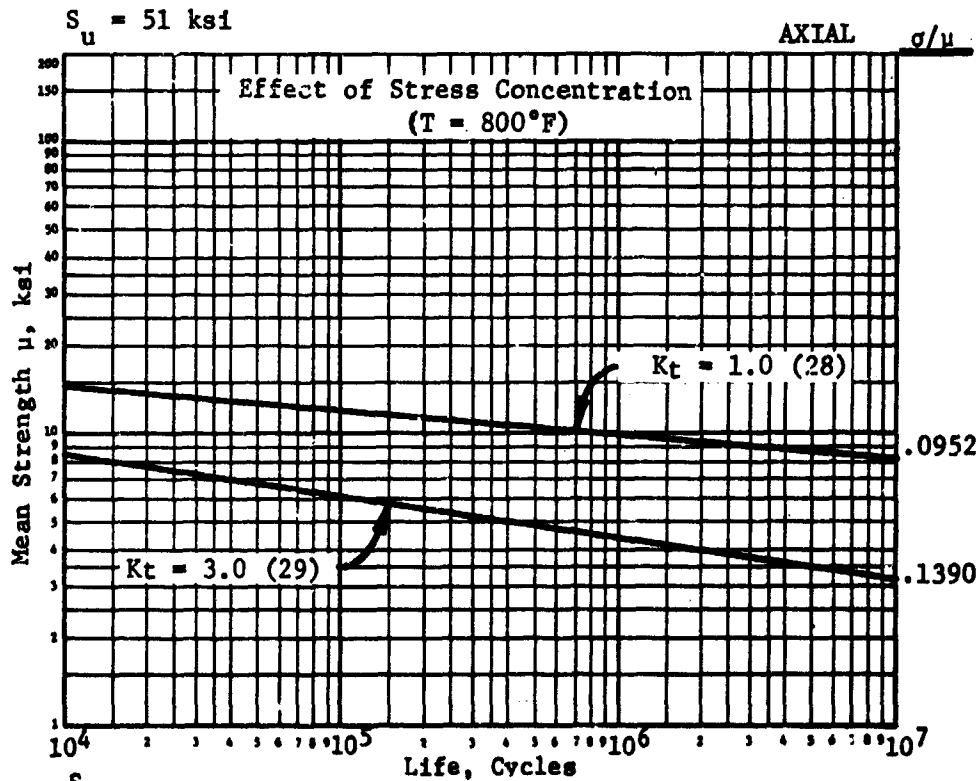

(Numbers in parentheses are the code numbers of the tabulated values.)

Figure 6.16

2014 ALUMINUM

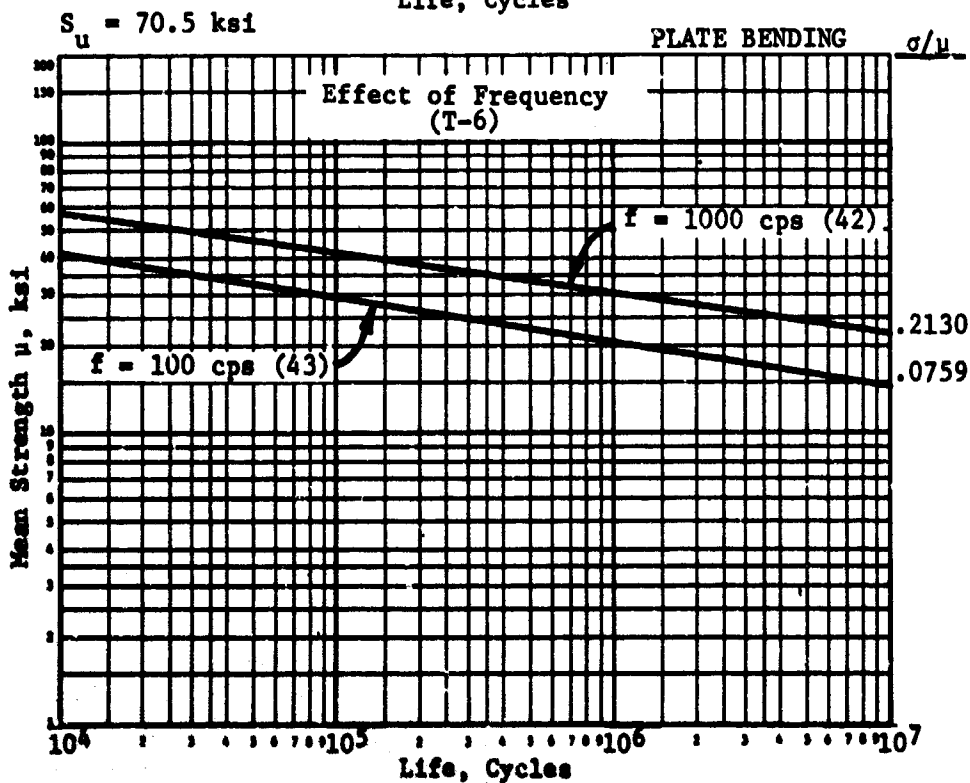
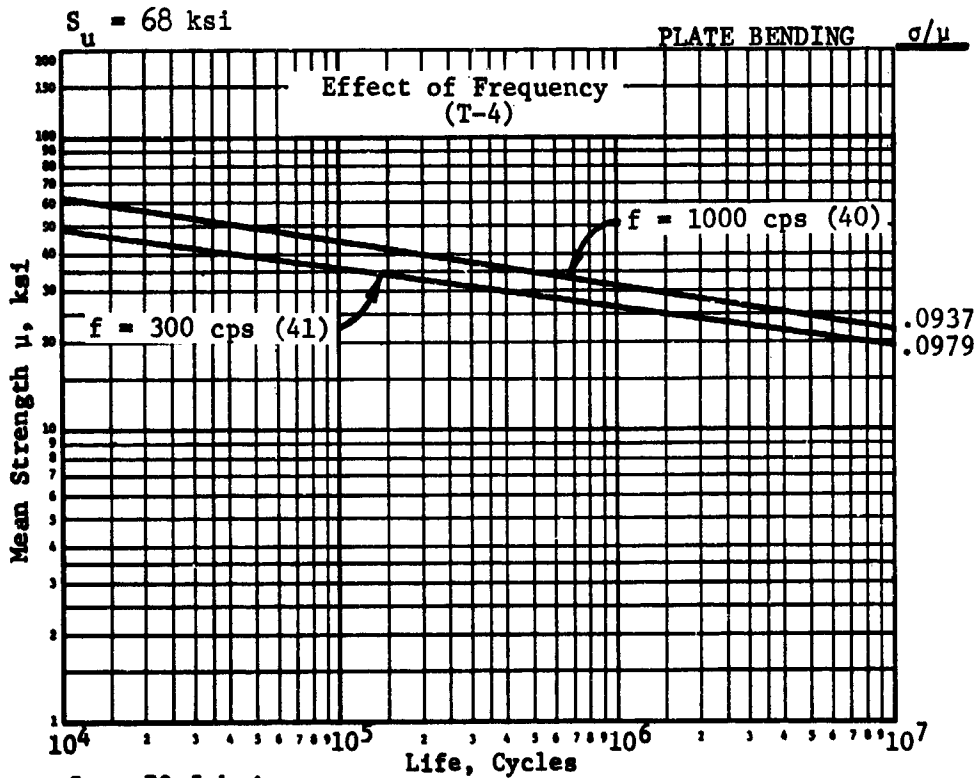

(Numbers in parentheses are the code numbers of the tabulated values.)

Figure 6.17

2014 ALUMINUM

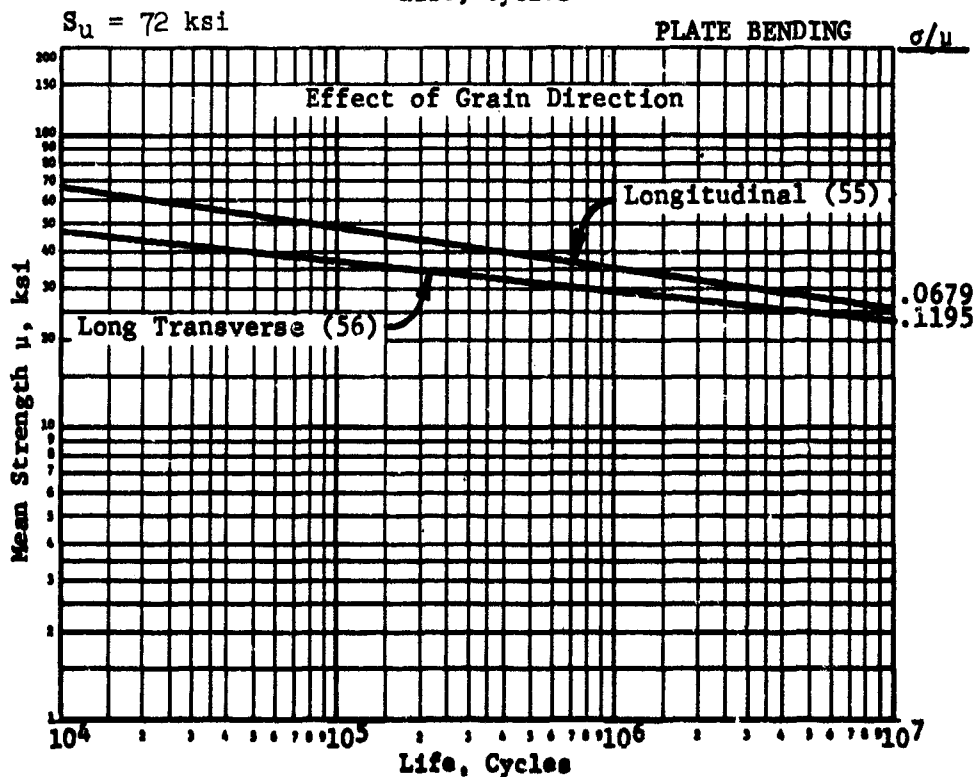
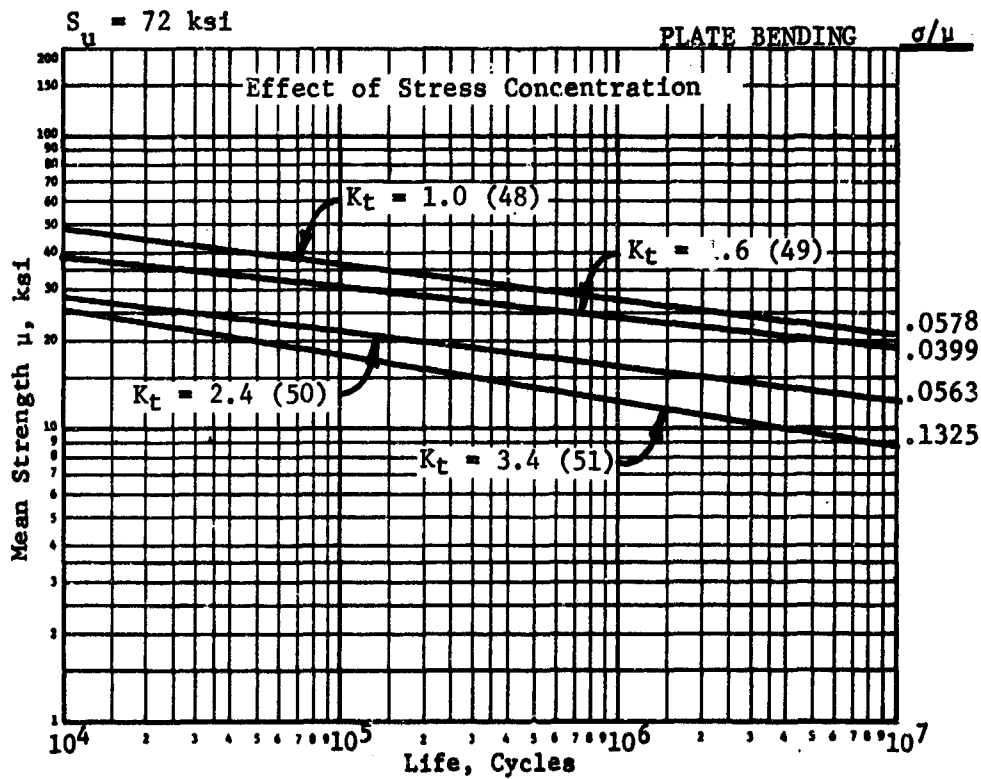

(Numbers in parentheses are the code numbers of the tabulated values.)

Figure 6.18

2014 ALUMINUM

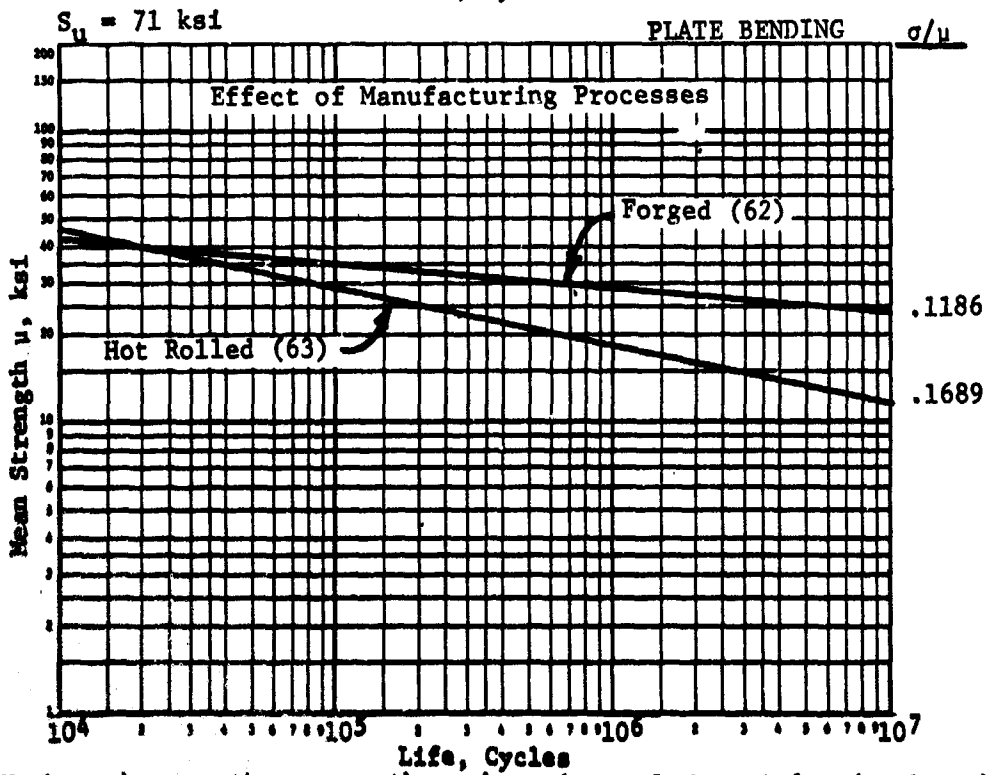
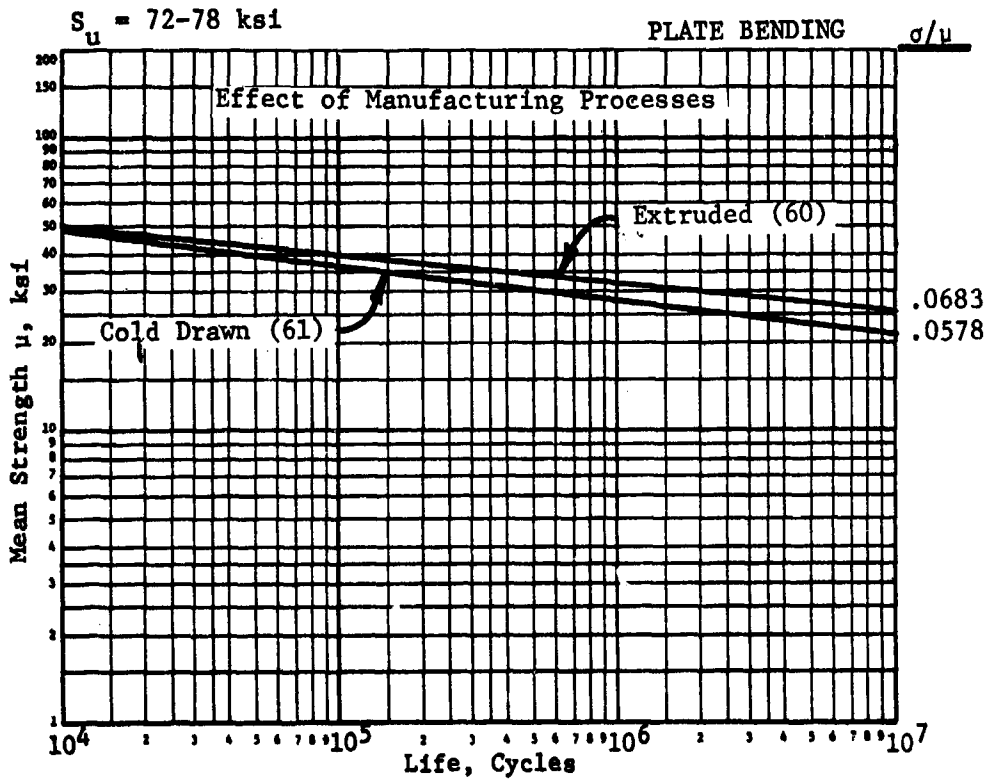

(Numbers in parentheses are the code numbers of the tabulated values.)

Figure 6.19

2014 ALCLAD ALUMINUM

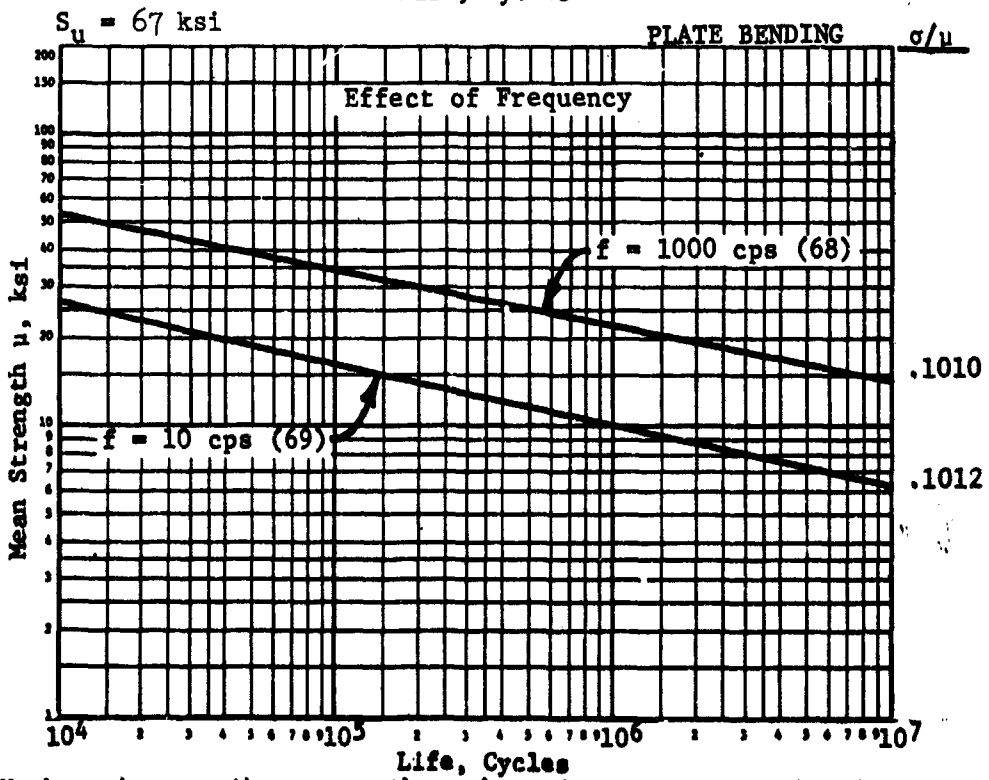
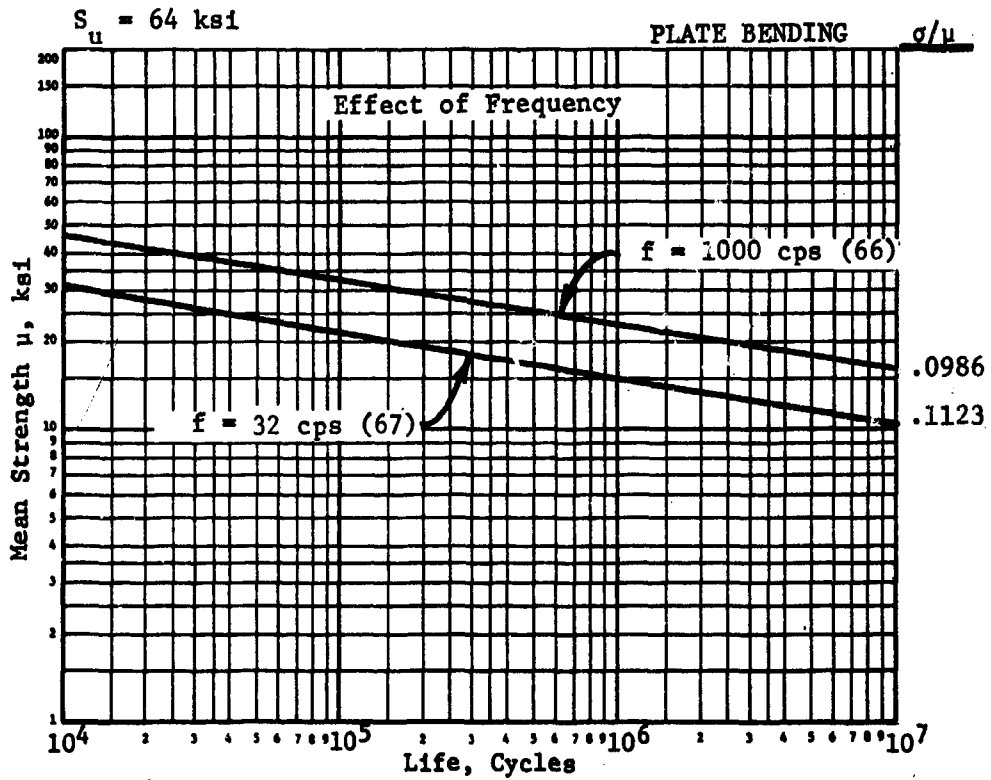

(Numbers in parentheses are the code numbers of the tabulated values.)

Figure 6.20

2024 ALUMINUM (SHEETS)

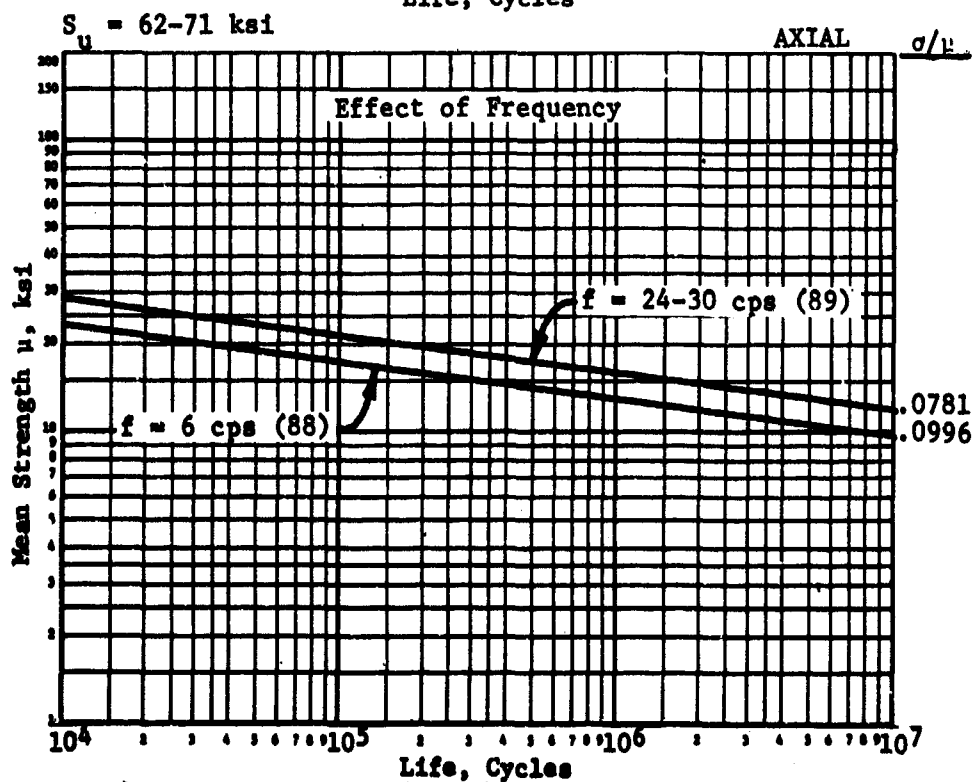
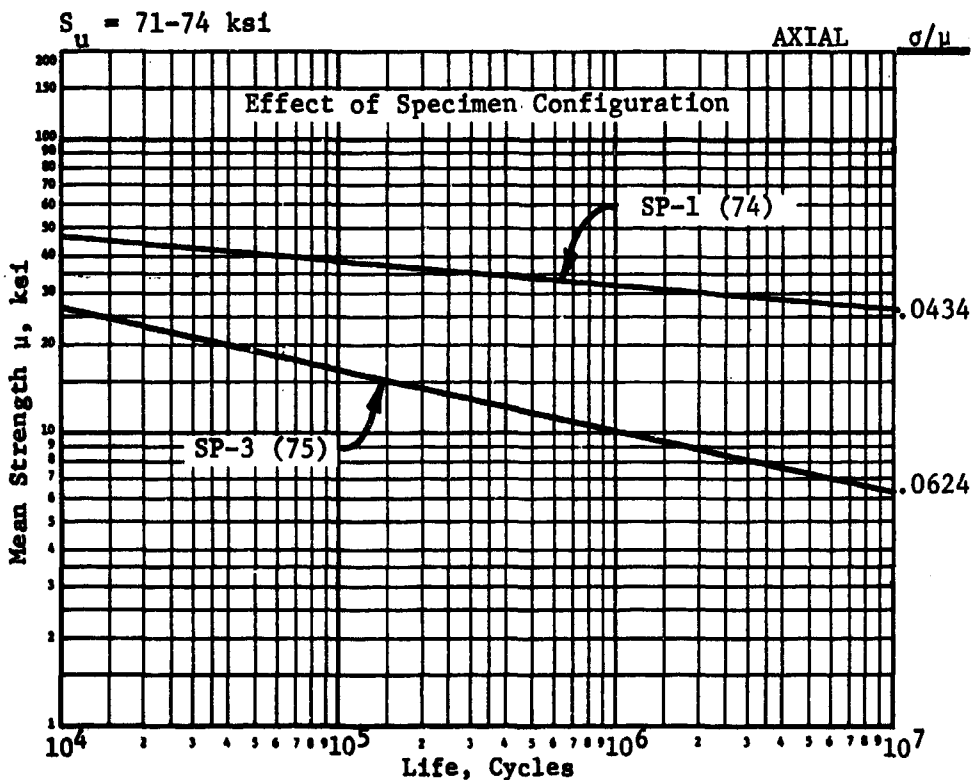

(Numbers in parentheses are the code numbers of the tabulated values.)

Figure 6.21

2024 ALUMINUM (SHEETS)

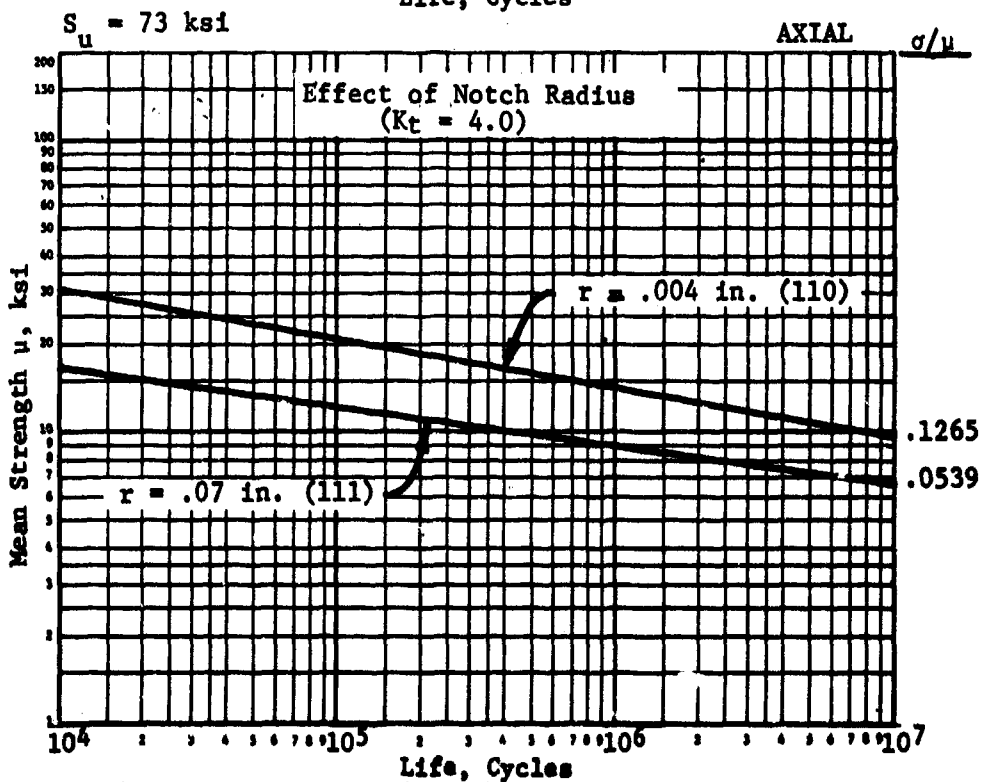
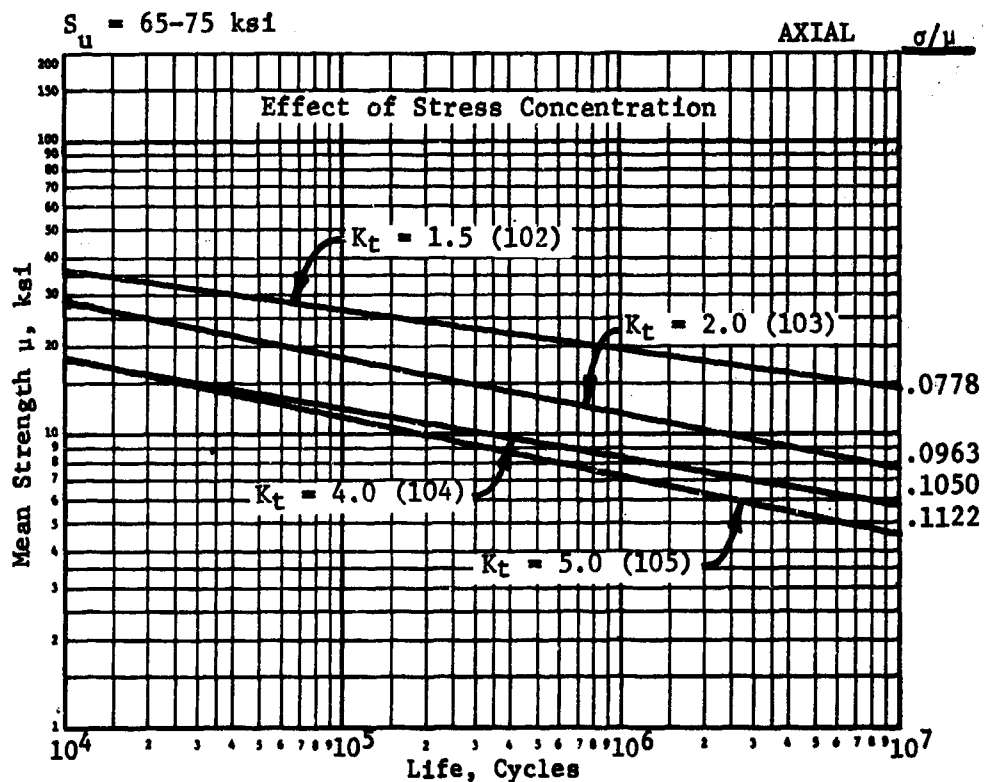

(Numbers in parentheses are the code numbers of the tabulated values.)

Figure 6.22



2024 ALUMINUM (BARS)

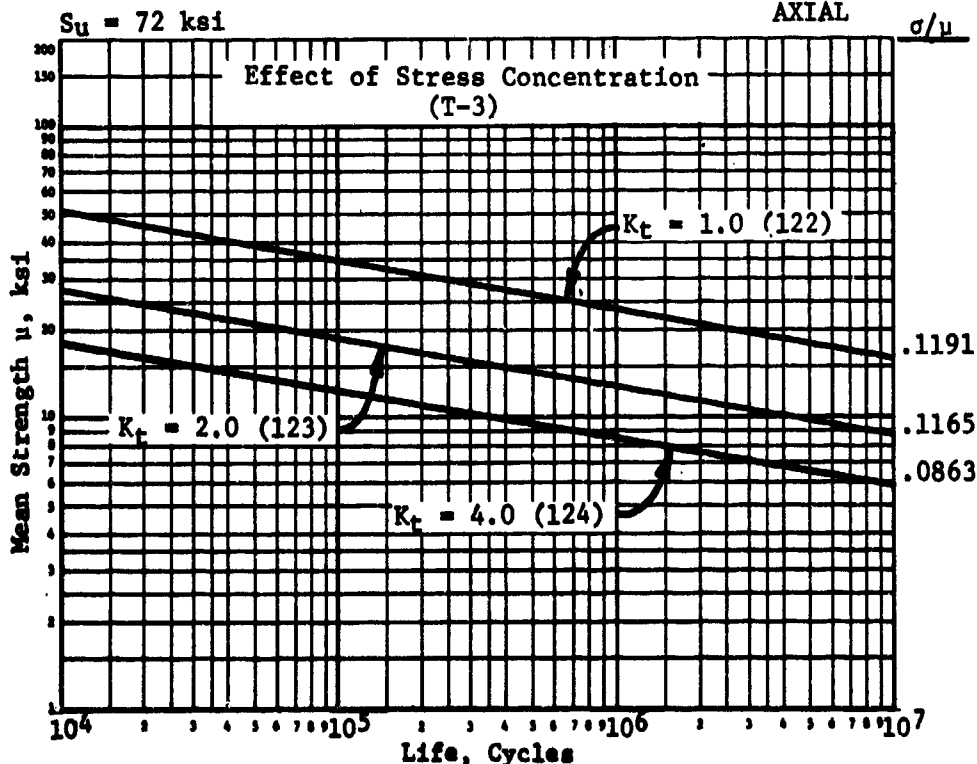
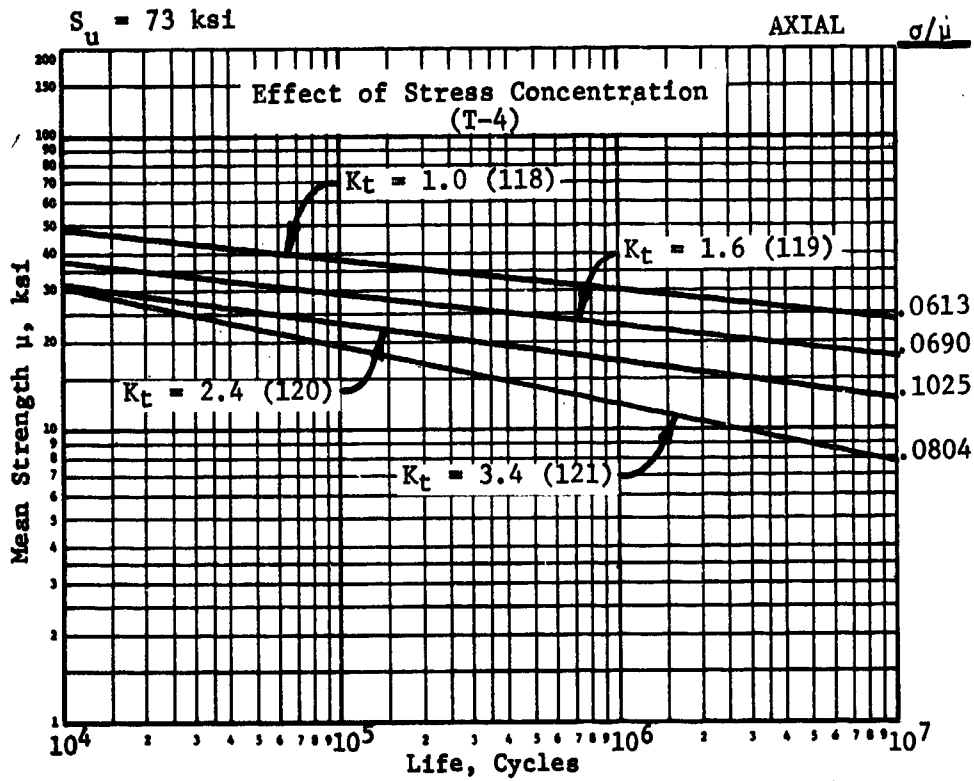

(Numbers in parentheses are the code numbers of the tabulated values.)

Figure 6.23

2024 ALUMINUM (EXTRUSIONS)

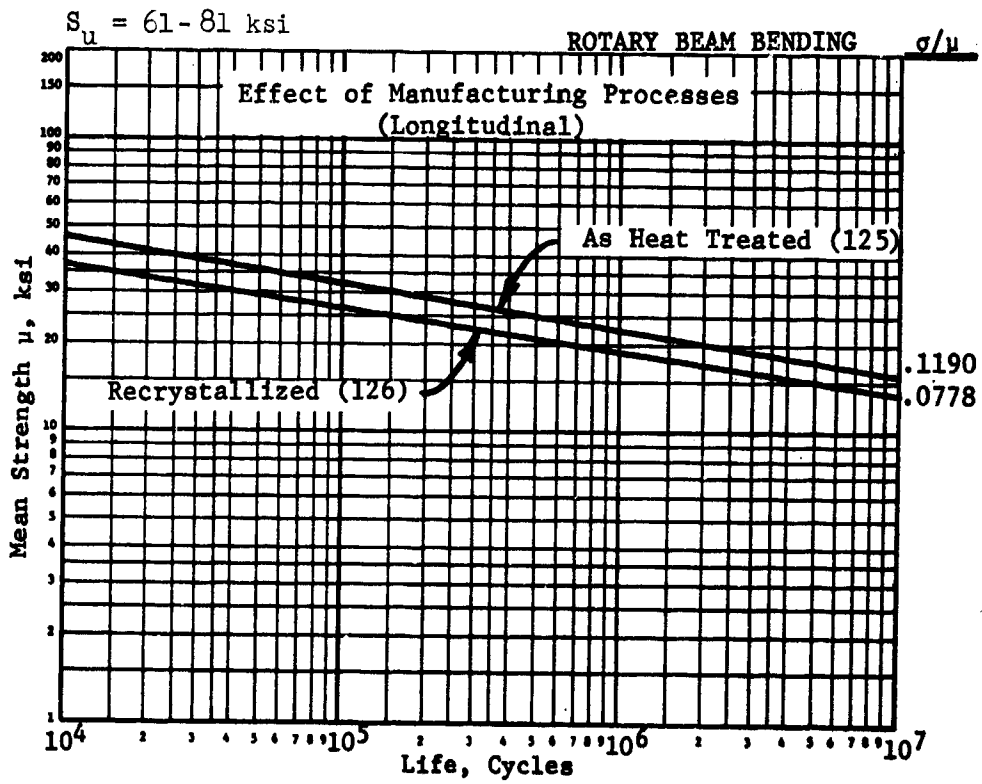

(Numbers in parentheses are the code numbers of the tabulated values.)

Figure 6.24

2025 ALUMINUM

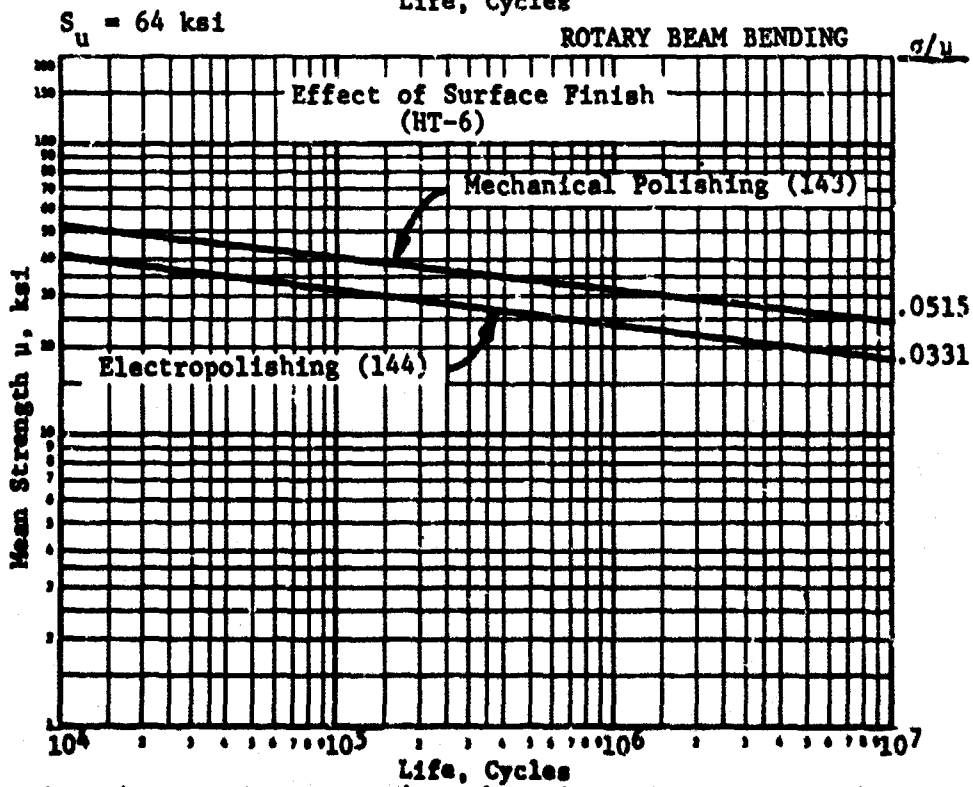
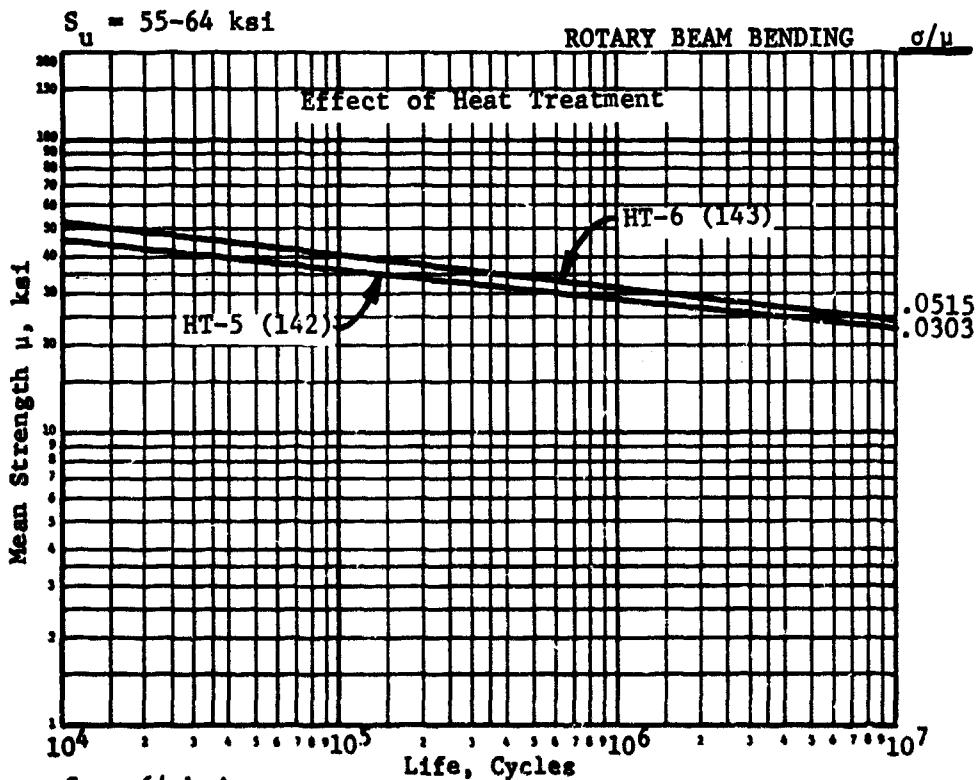

(Numbers in parentheses are the code numbers of the tabulated values.)

Figure 6.25

2025 ALUMINUM

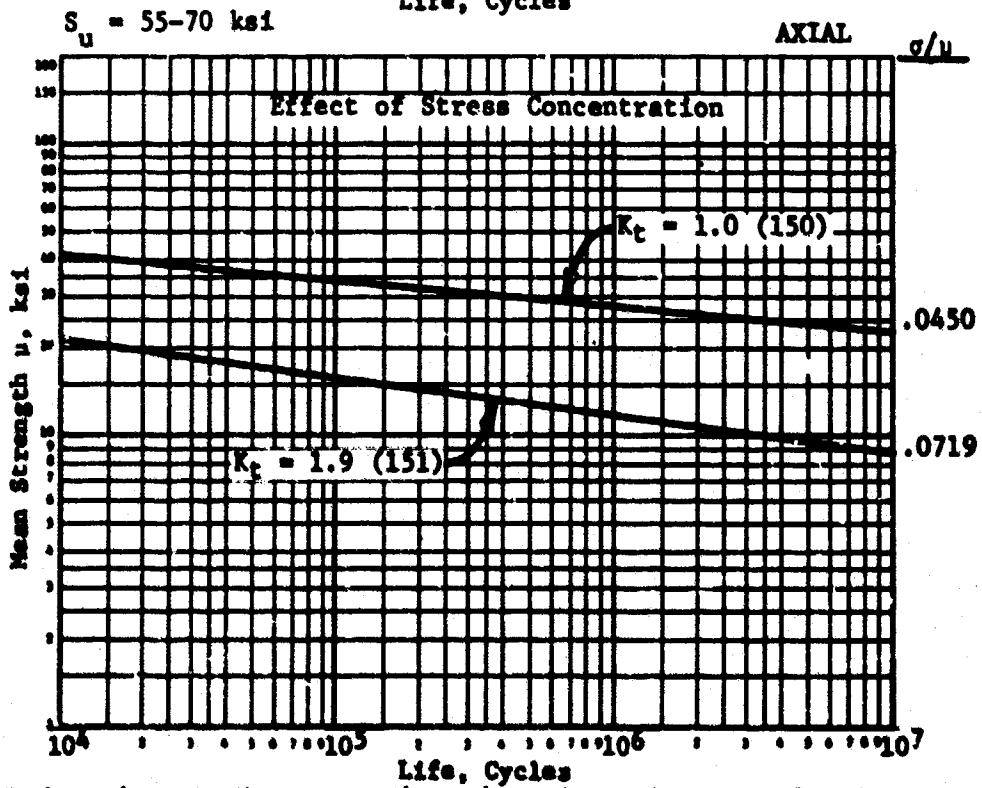
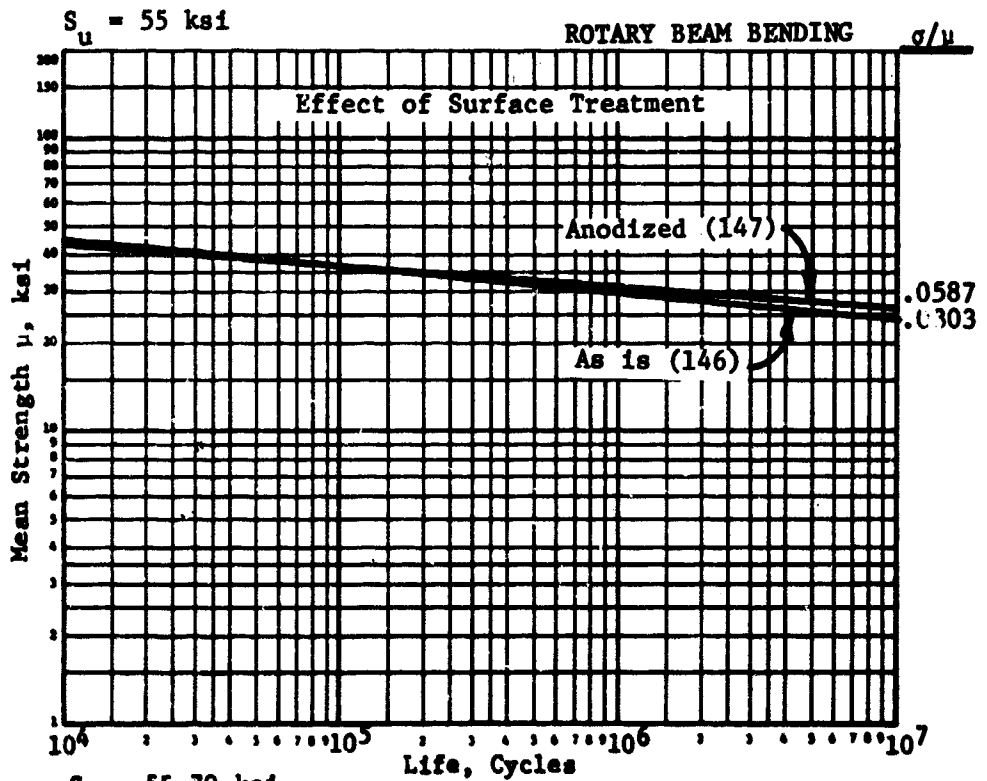

(Numbers in parentheses are the code numbers of the tabulated values.)

Figure 6.26

2219 ALUMINUM

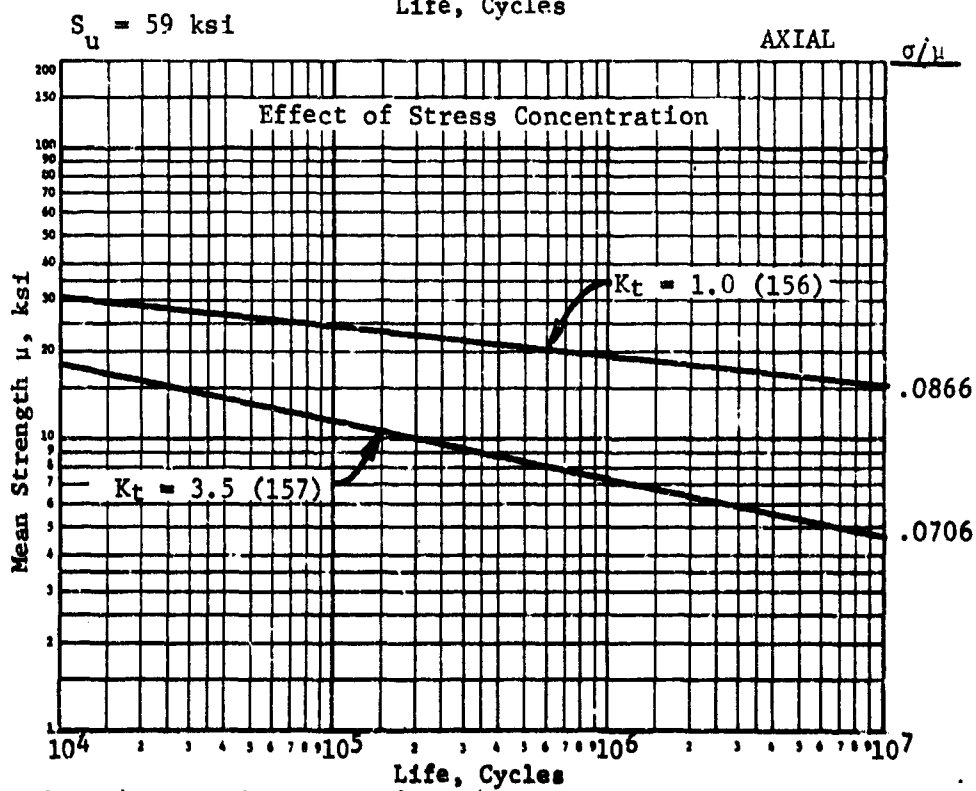
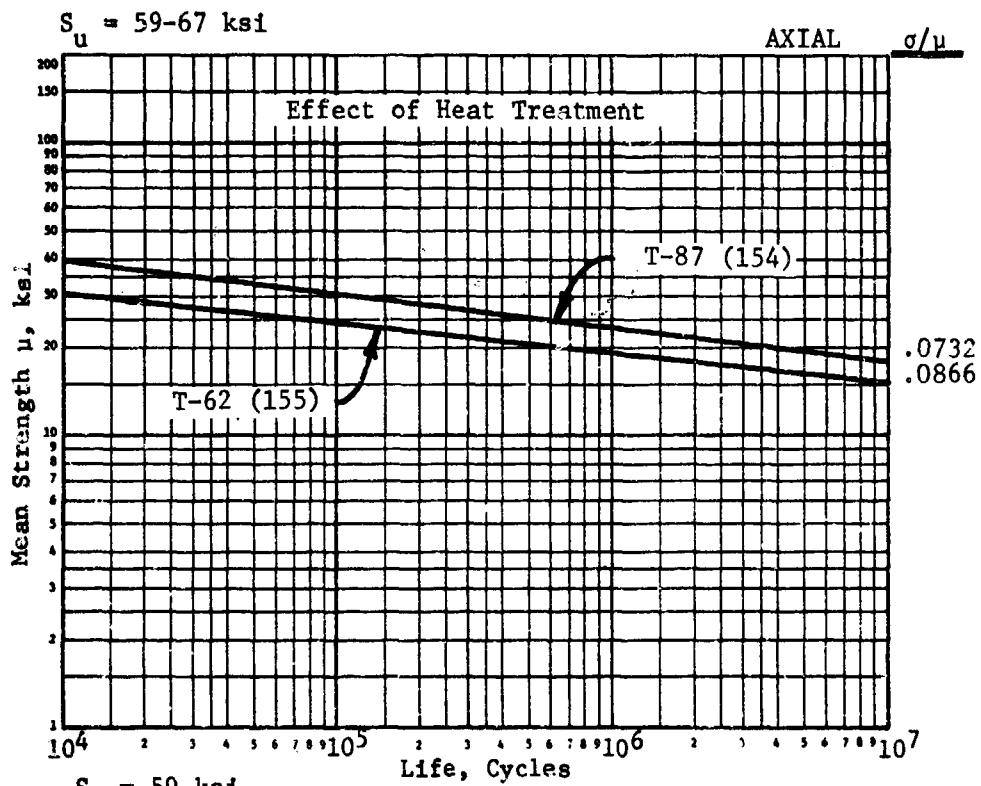

(Numbers in parentheses are the code numbers of the tabulated values.)

Figure 6.27

2618 ALUMINUM

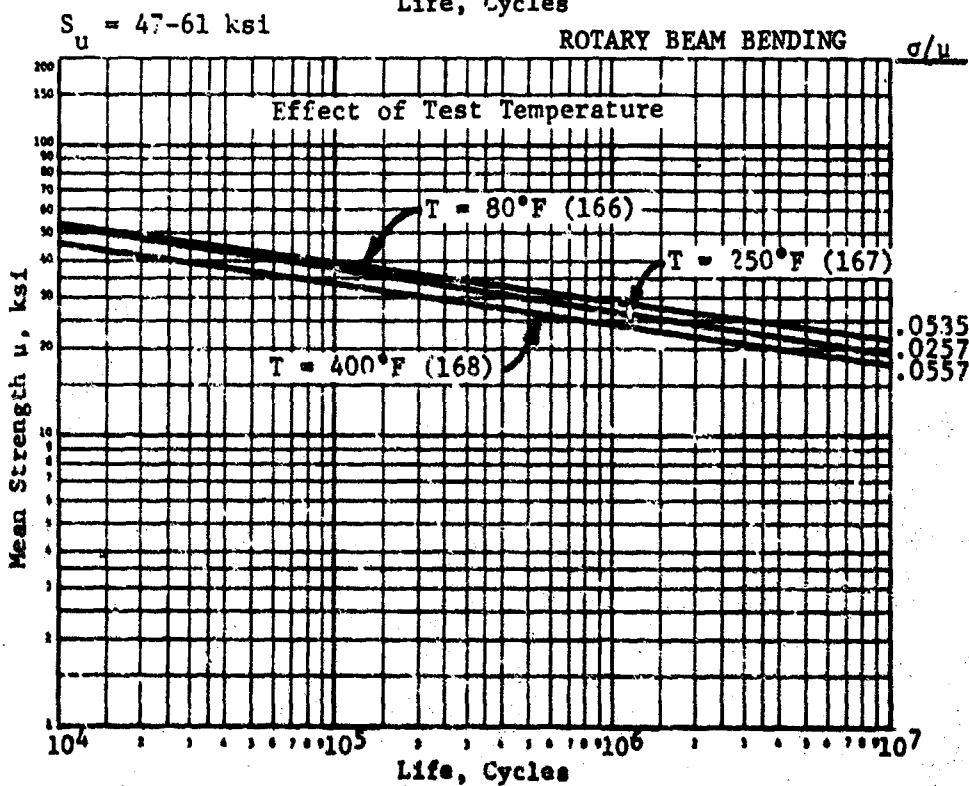
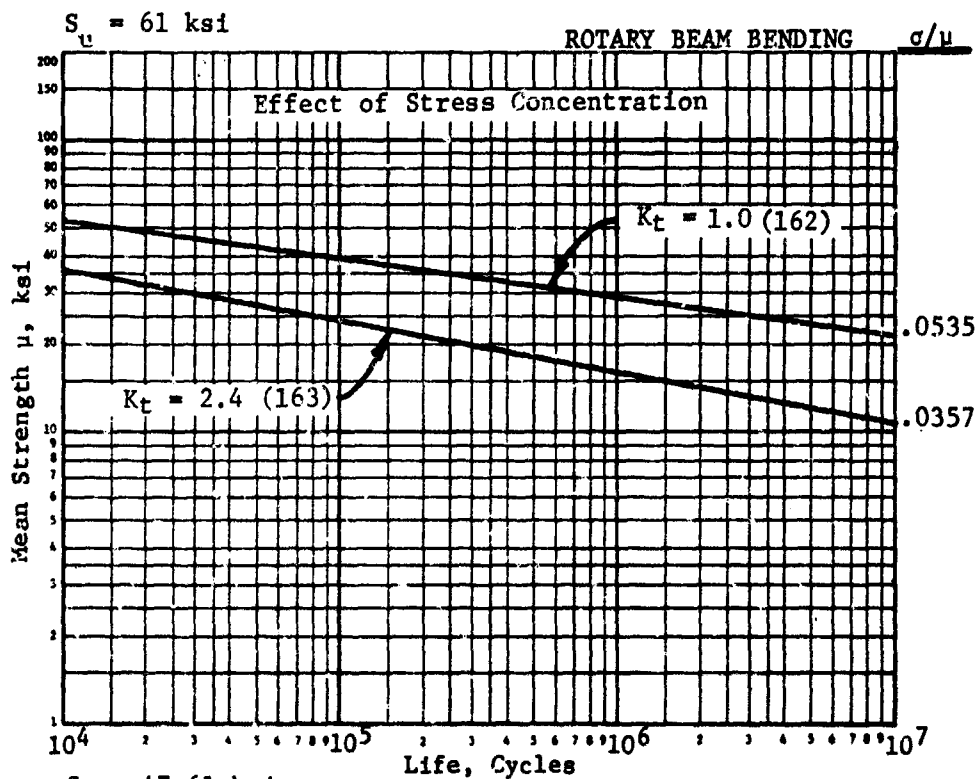

(Numbers in parentheses are the code numbers of the tabulated values.)

Figure 6.28

7001 ALUMINUM

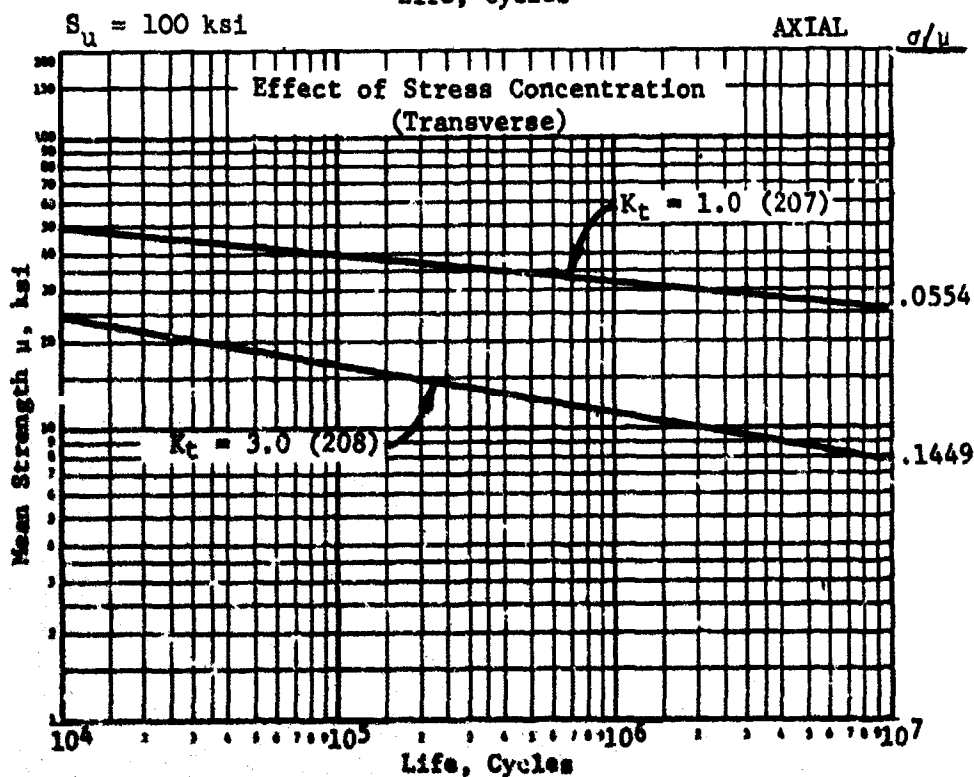
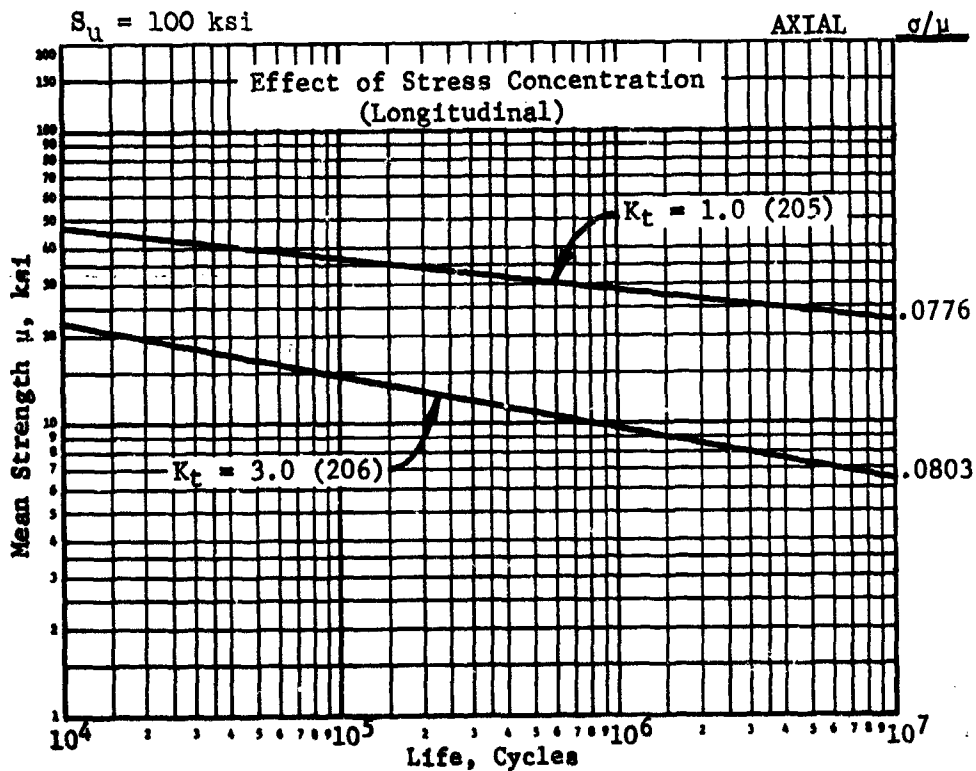

(Numbers in parentheses are the code numbers of the tabulated values.)

Figure 6.29

7075 ALUMINUM (SHEETS)

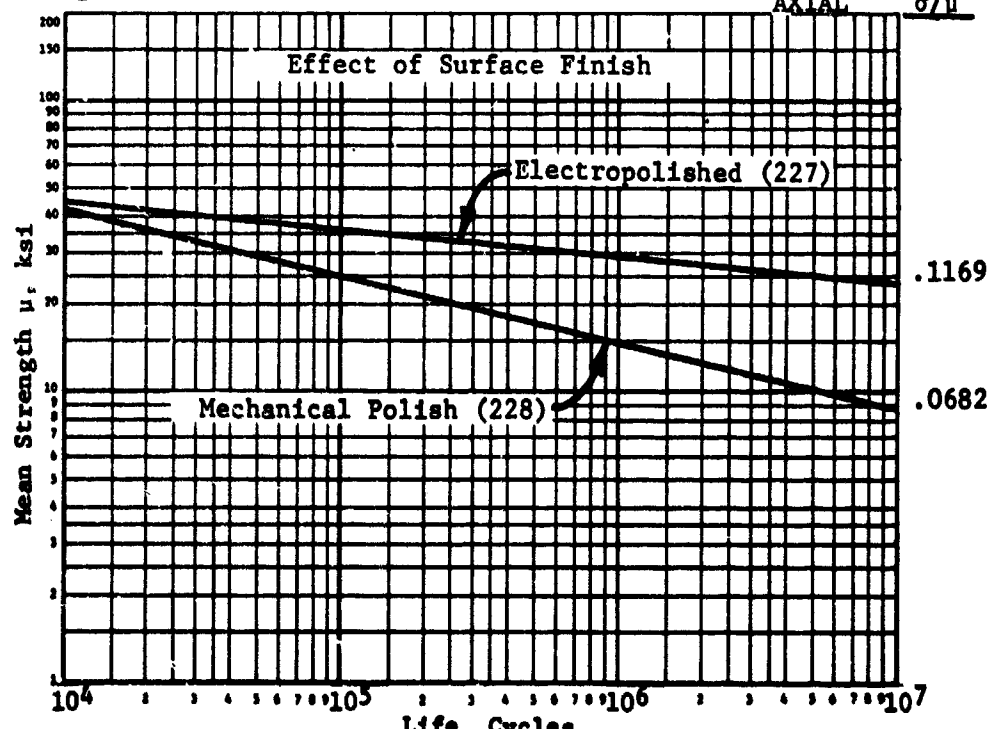
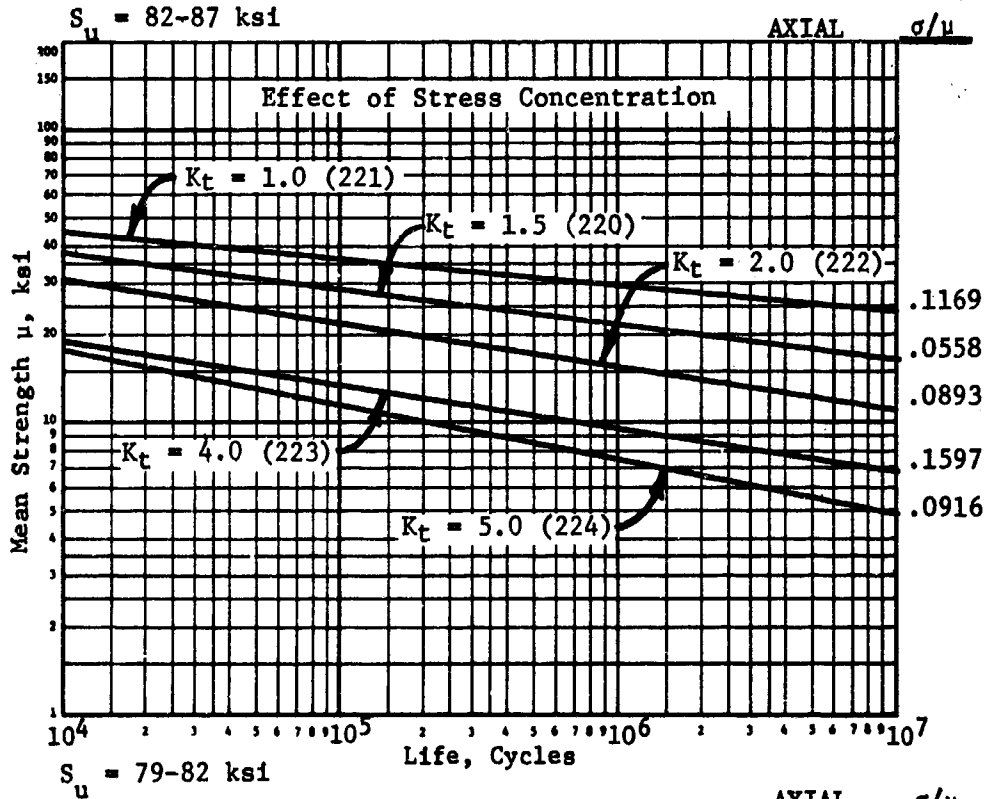

(Numbers in parentheses are the code numbers of the tabulated values.)

Figure 6.30



7075 ALUMINUM (BAR)

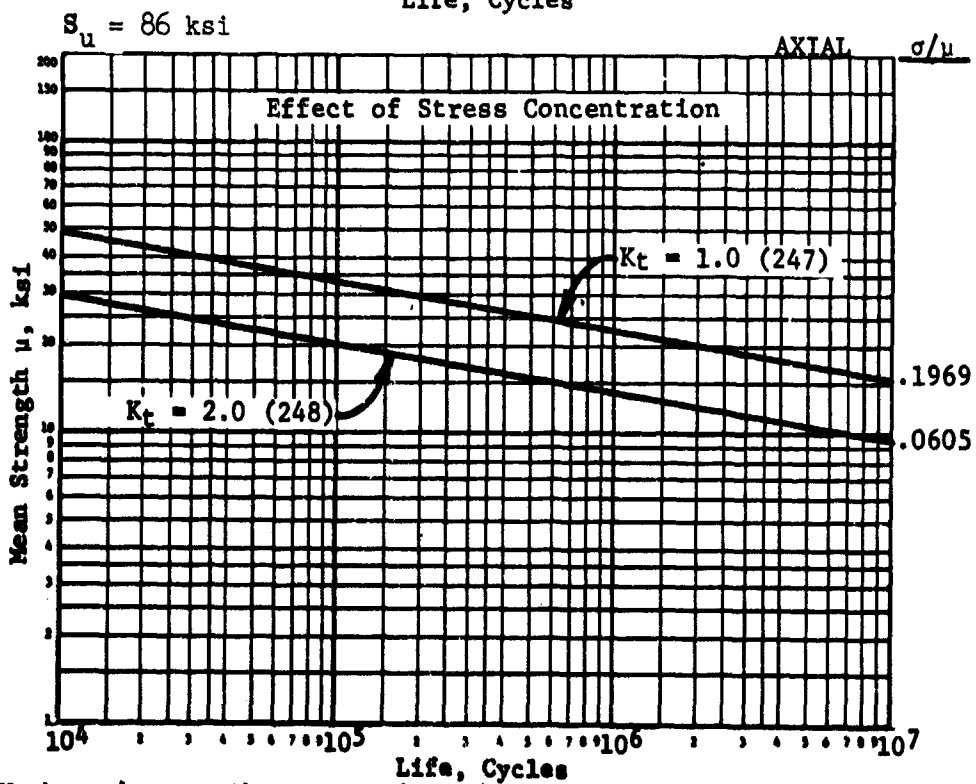
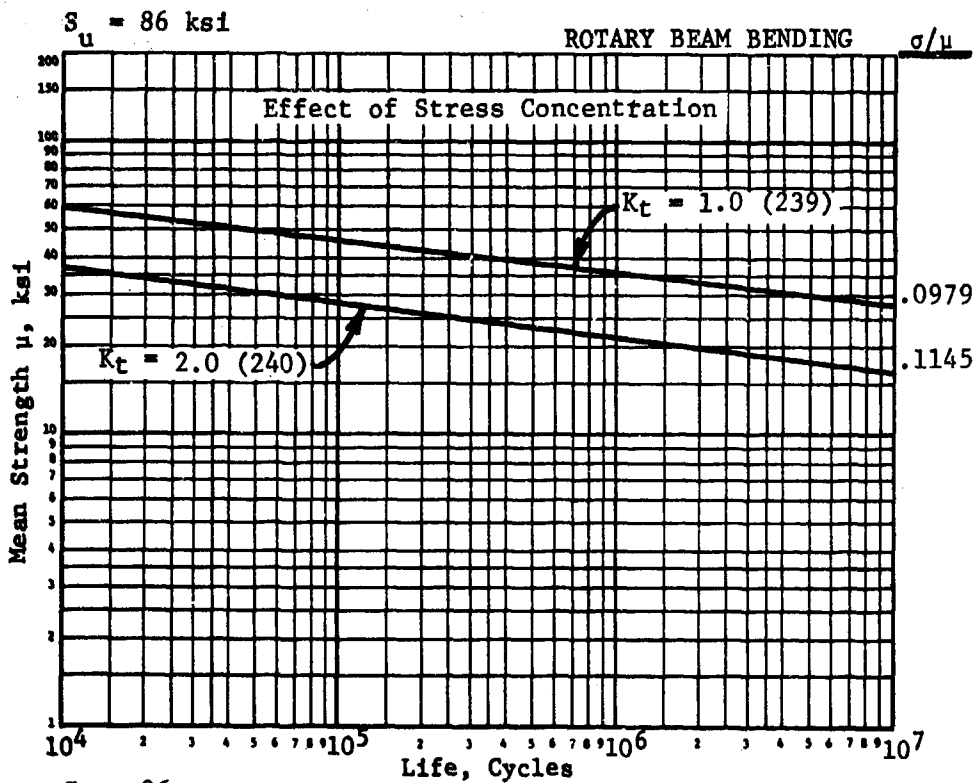

(Numbers in parentheses are the code numbers of the tabulated values.)

Figure 6.31

7075 ALUMINUM  
EXTRUSIONS AND FORGINGS

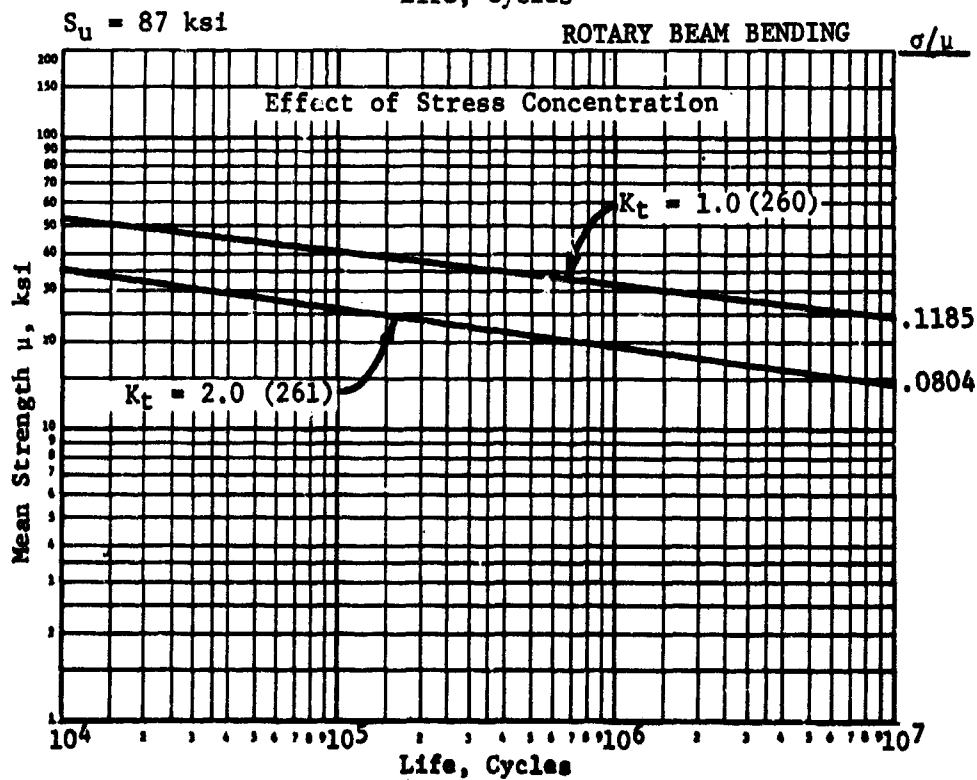
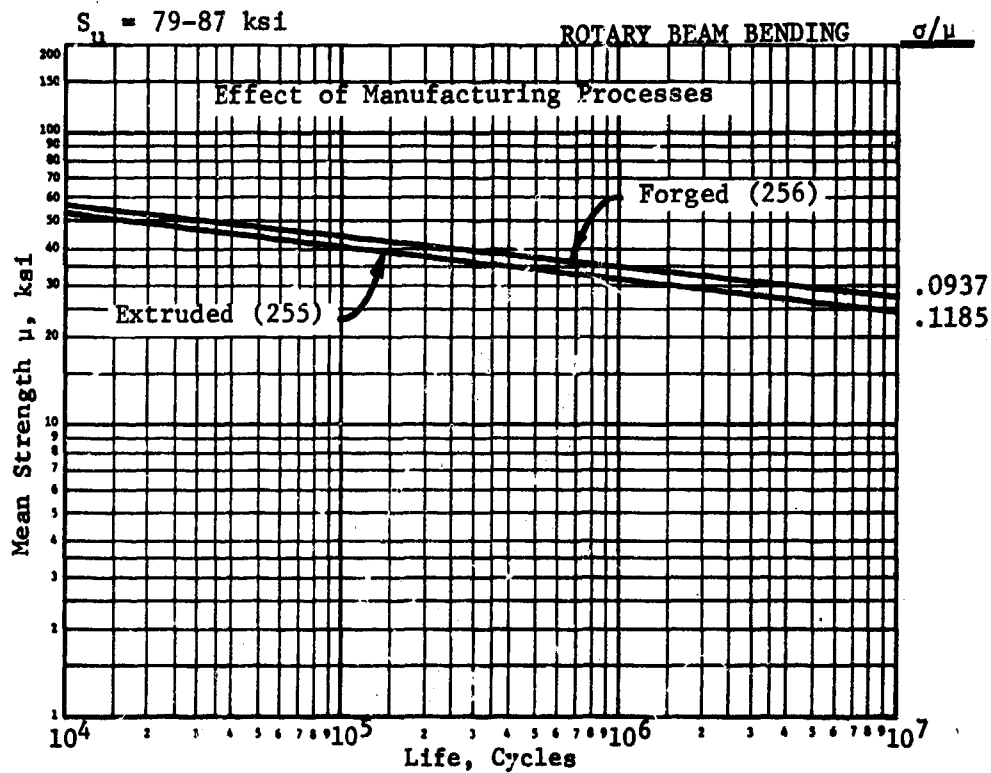

(Numbers in parentheses are the code numbers of the tabulated values.)

Figure 6.32

STELLITE - 31

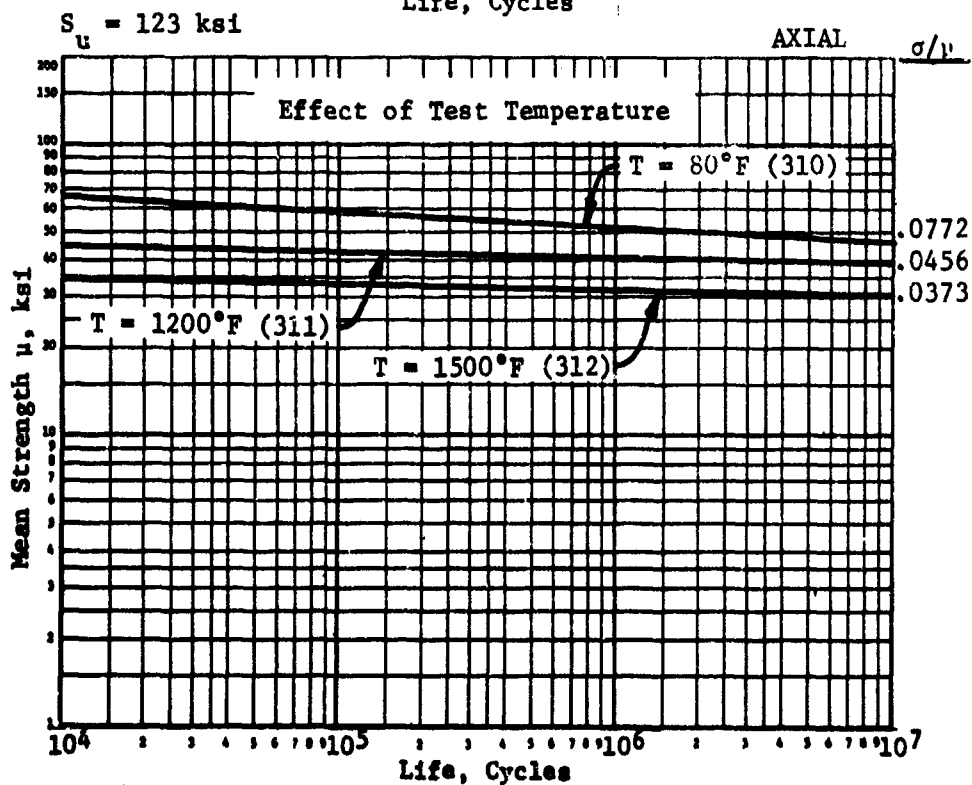
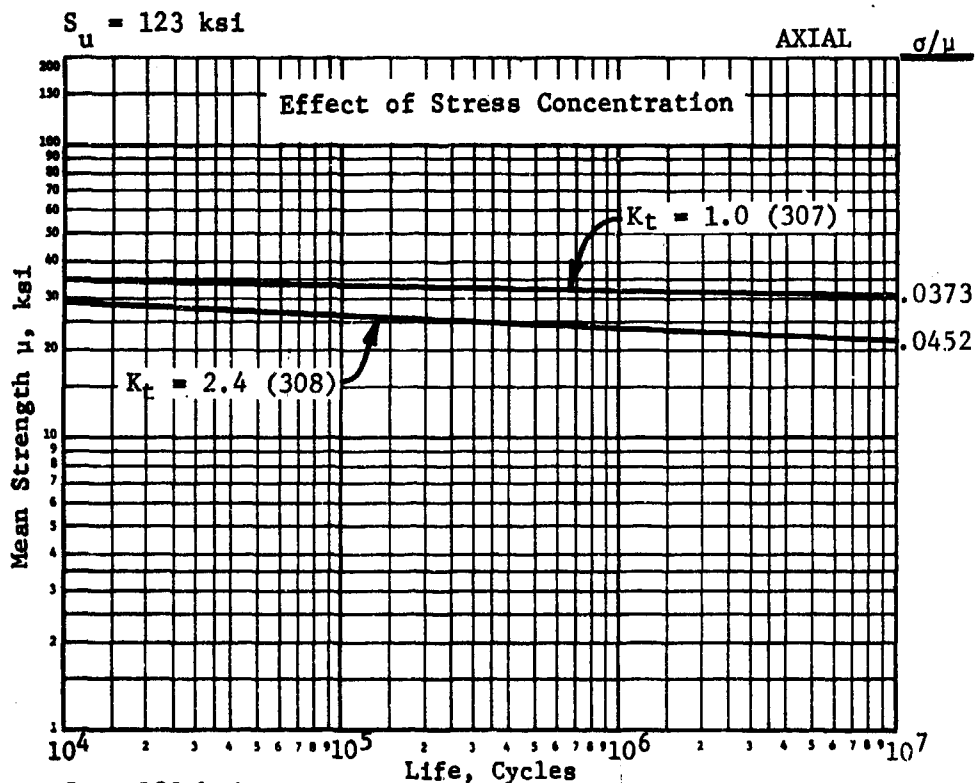

(Numbers in parentheses are the code numbers of the tabulated values.)

Figure 6.33

ZK60A MAGNESIUM

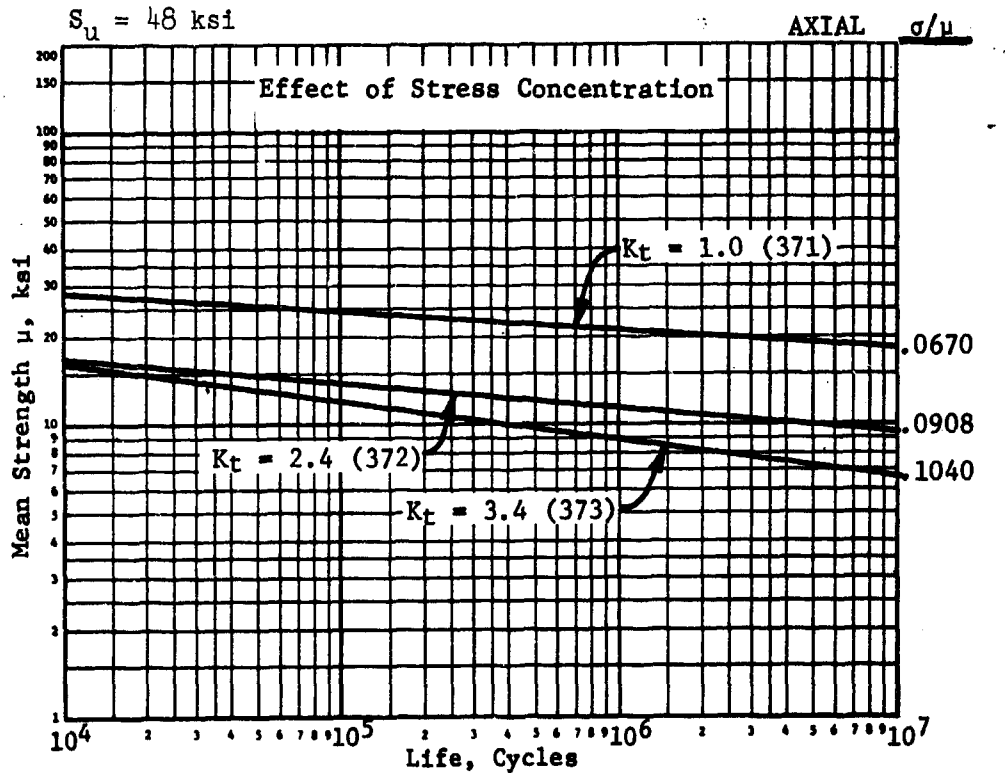

(Numbers in parentheses are the code numbers of the tabulated values.)

Figure 6.34

FS-27 NICKEL

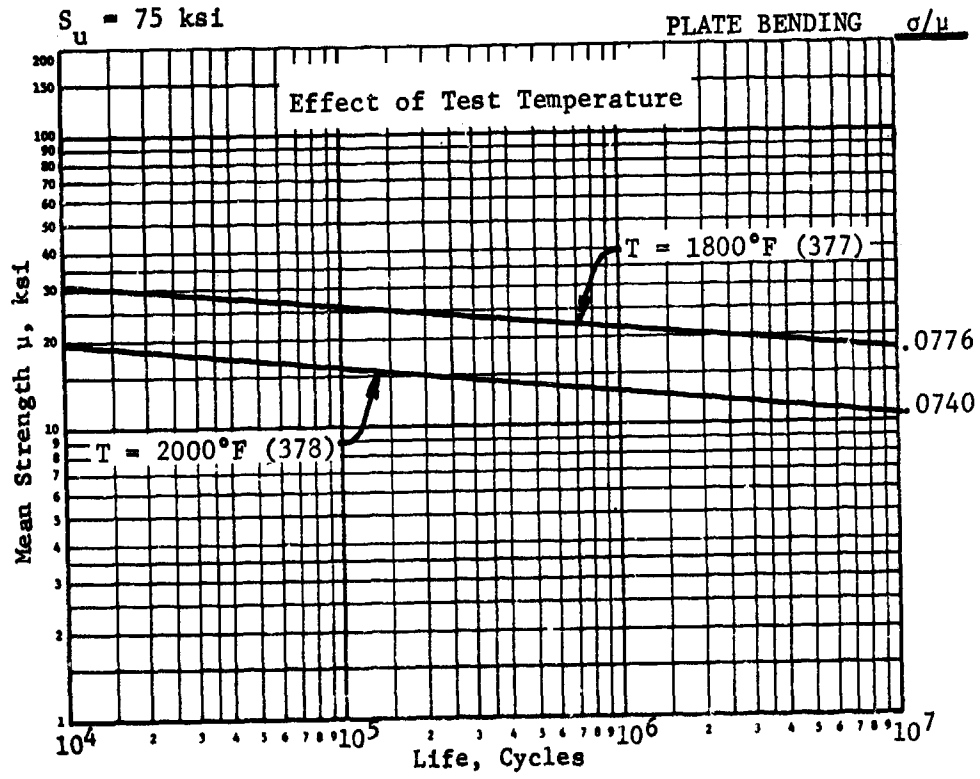

(Numbers in parentheses are the code numbers of the tabulated values.)

Figure 6.35

HASTELLOY - R235

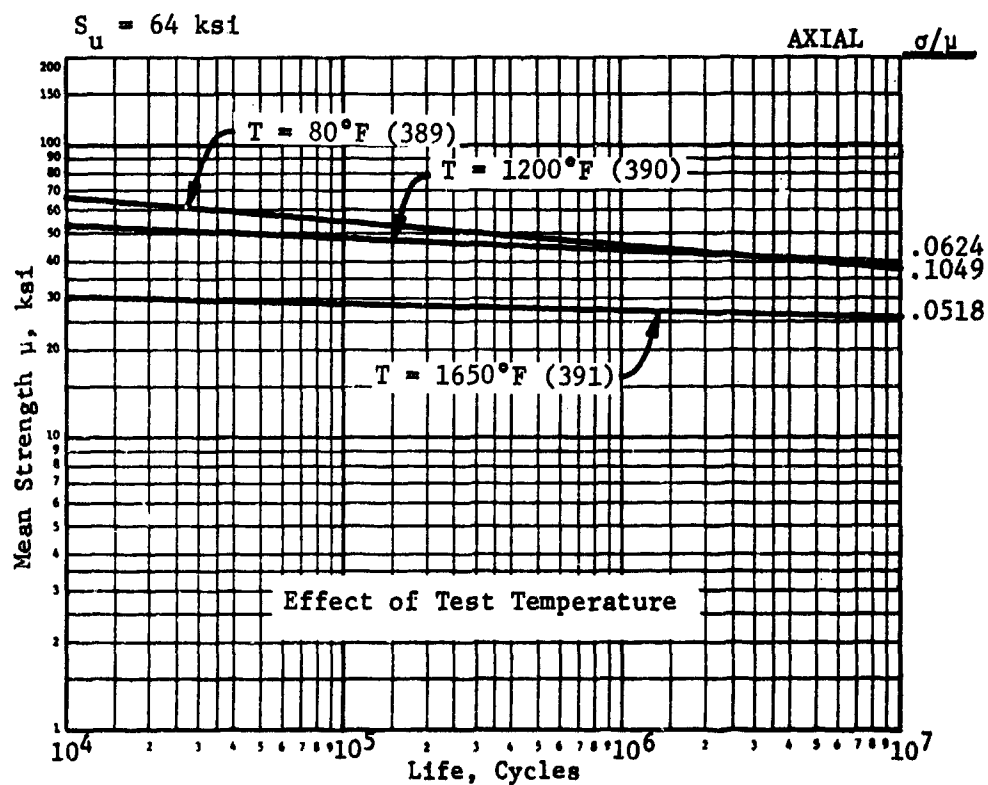

(Numbers in parentheses are the code numbers of the tabulated values.)

Figure 6.36

UDIMET - 500

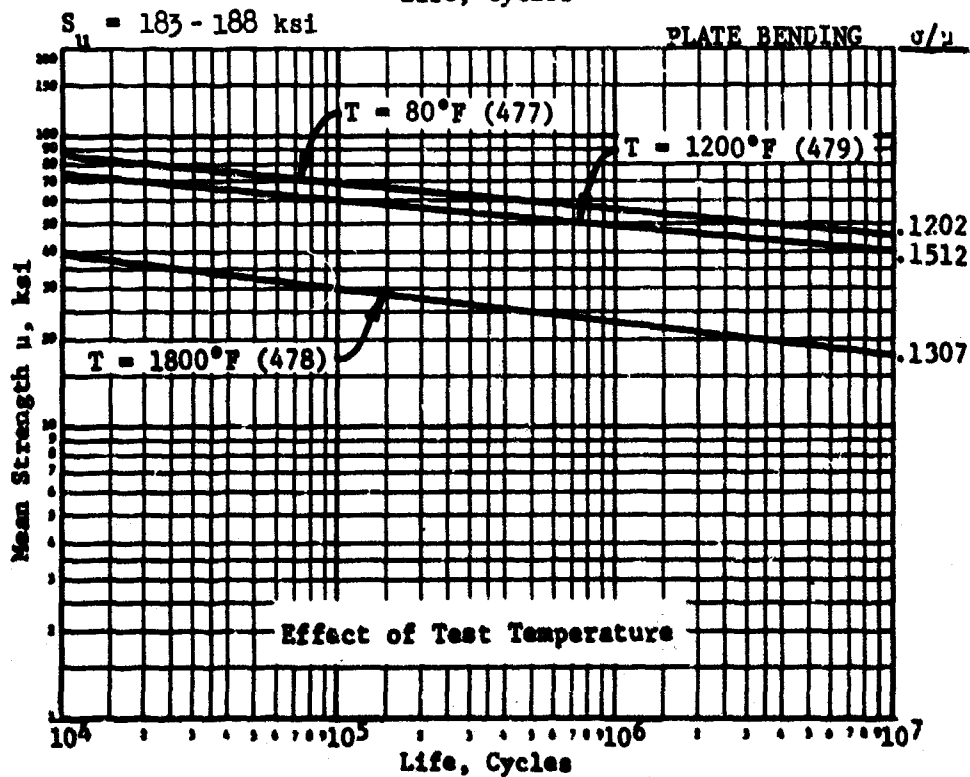
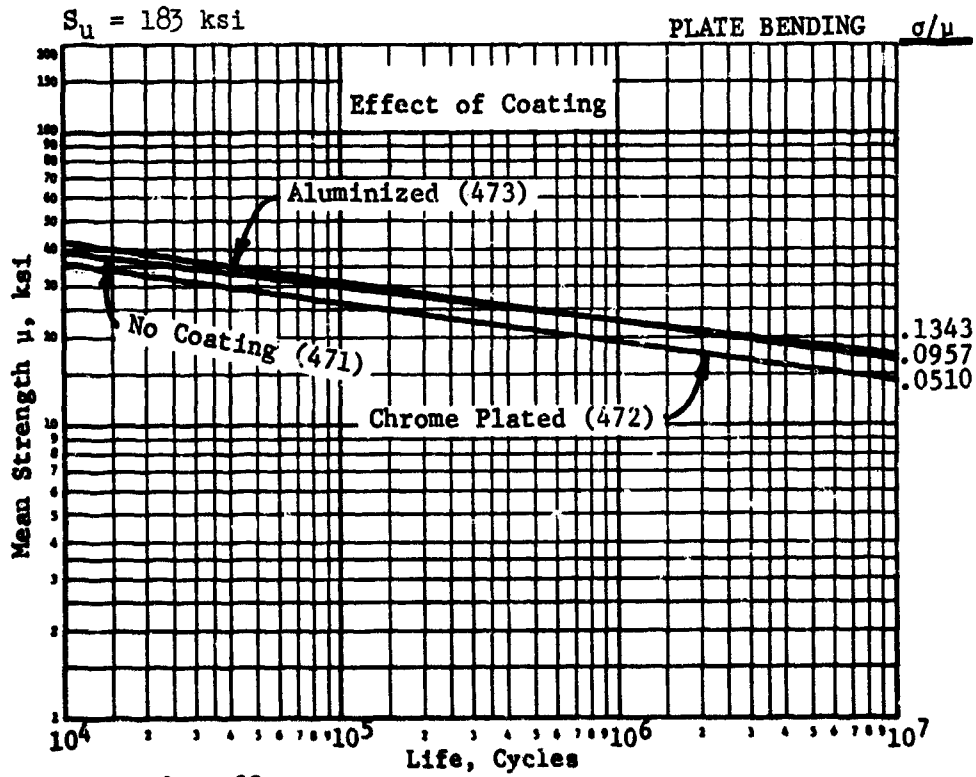

(Numbers in parentheses are the code numbers of the tabulated values.)

Figure 6.37

6 Mo WASPALLOY

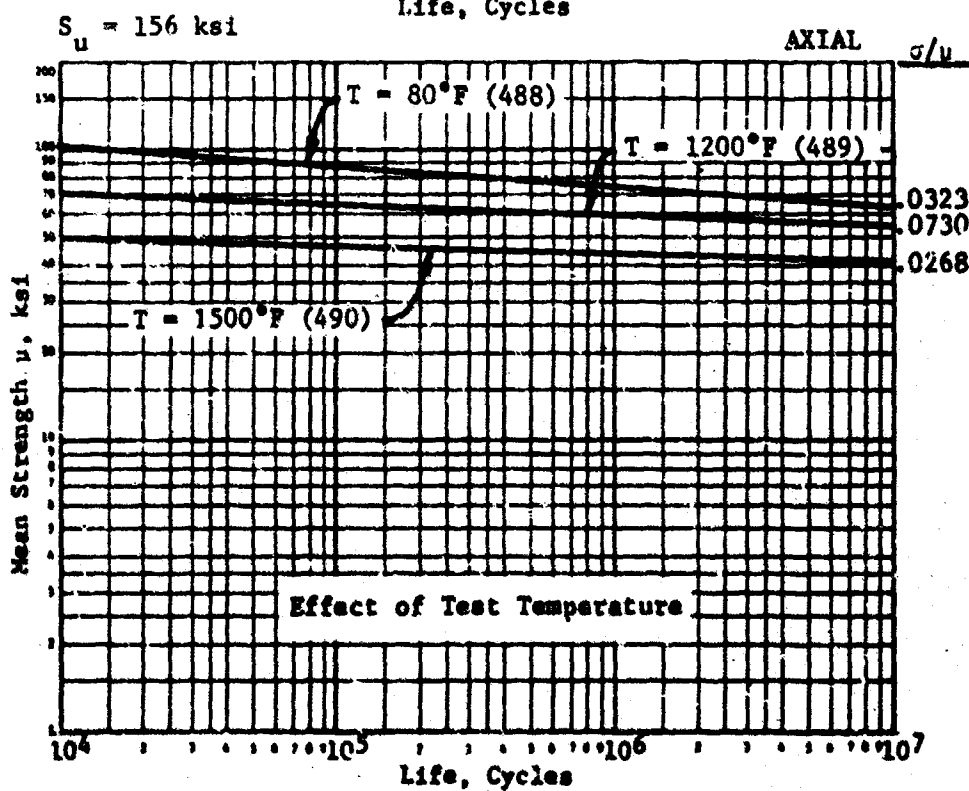
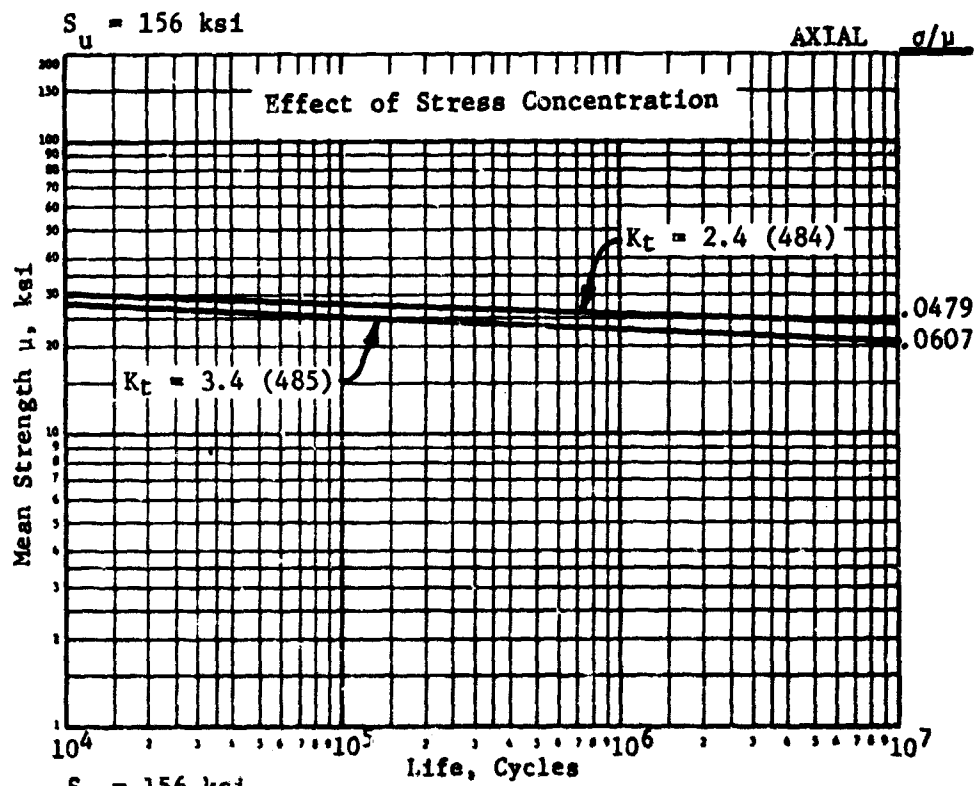

(Numbers in parentheses are the code numbers of the tabulated values.)

Figure 6.38



Ti - A55

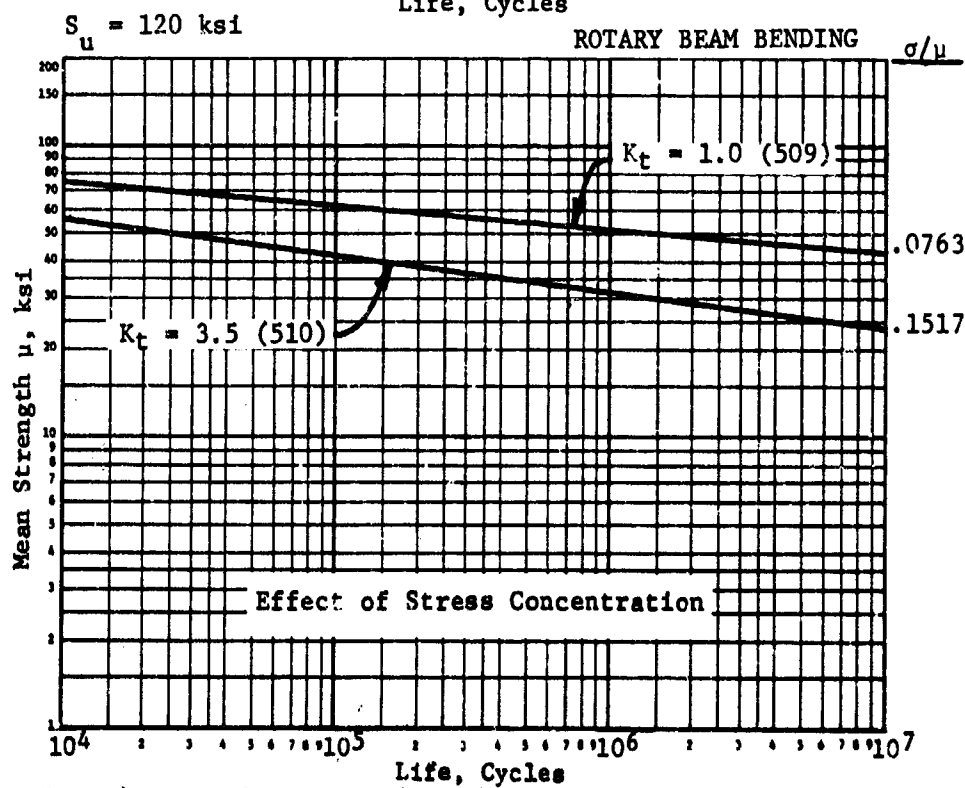
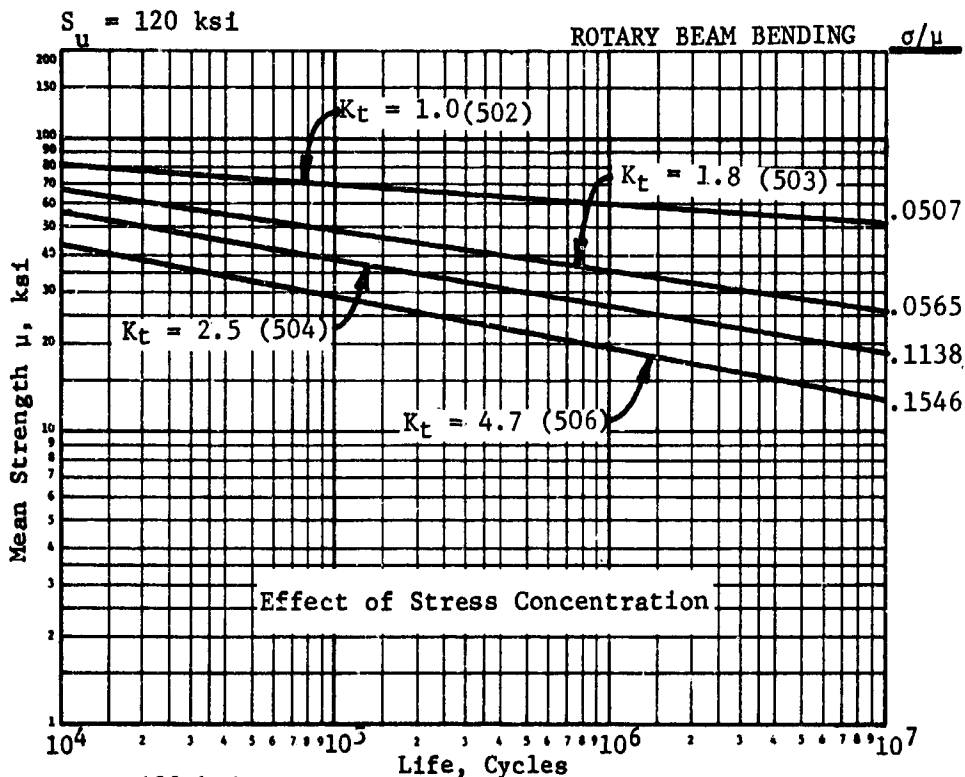

(Numbers in parentheses are the code numbers of the tabulated values.)

Figure 6.39

T1 - 75A

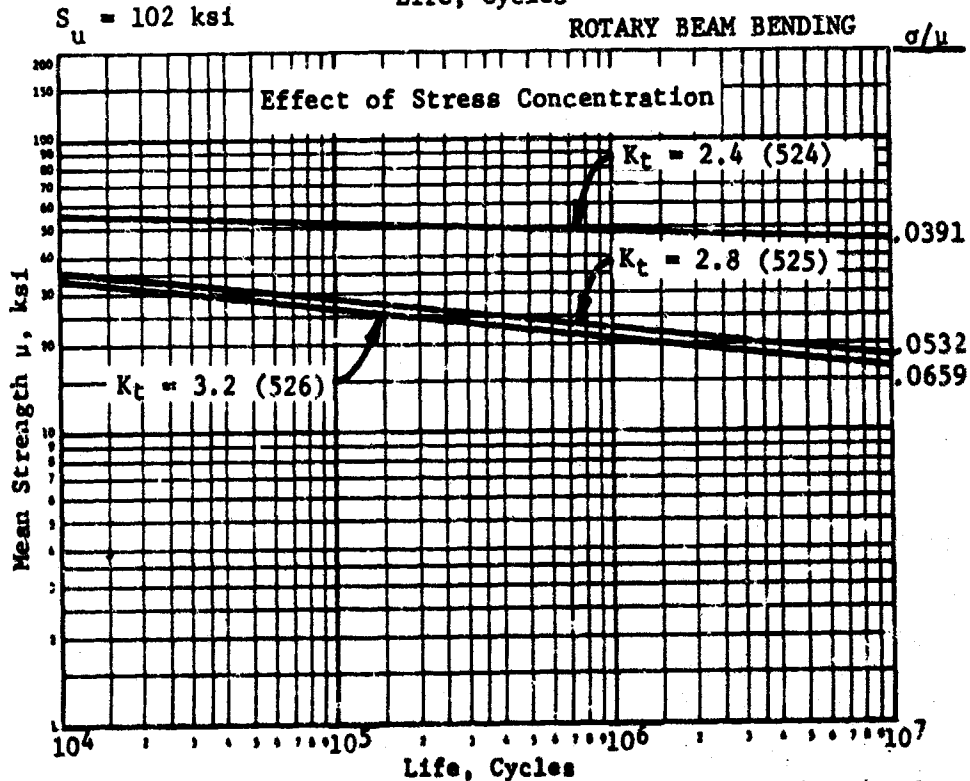
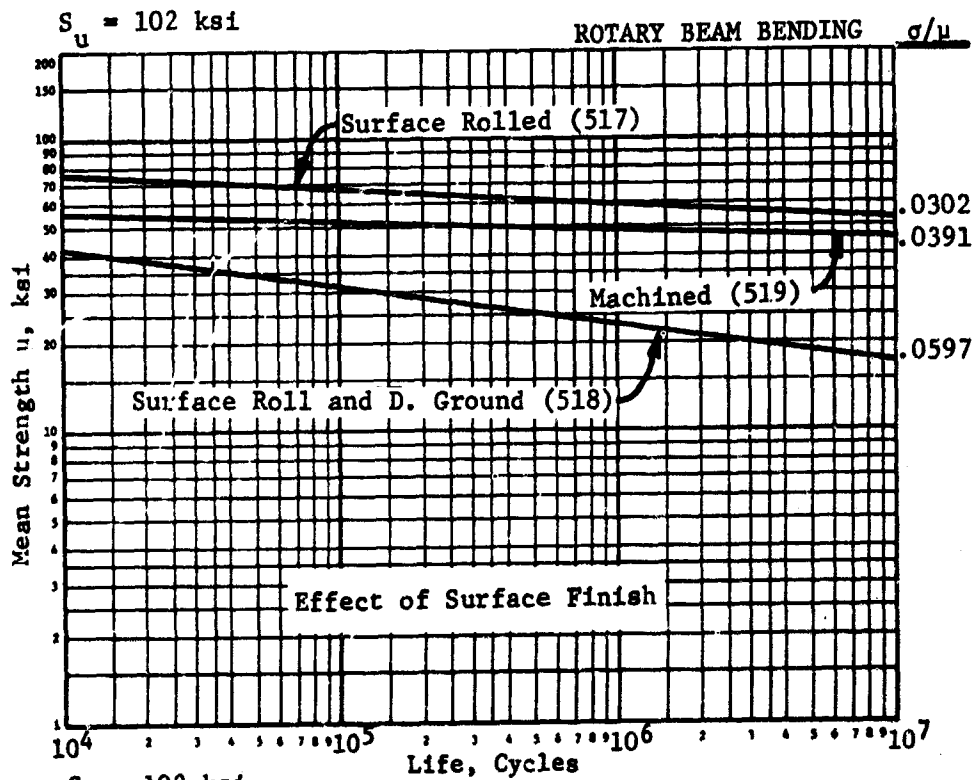

(Numbers in parentheses are the code numbers of the tabulated values.)

Figure 6.40

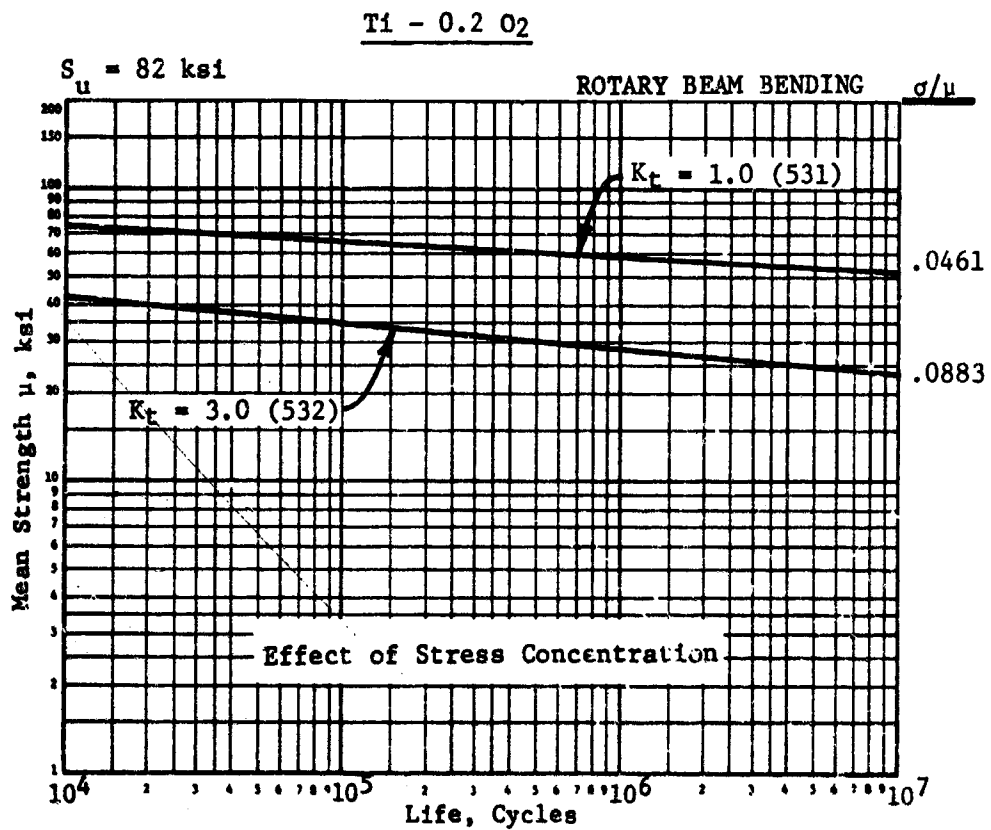

(Numbers in parentheses are the code numbers of the tabulated values.)

Figure 6.41

T1 - 0.2 C

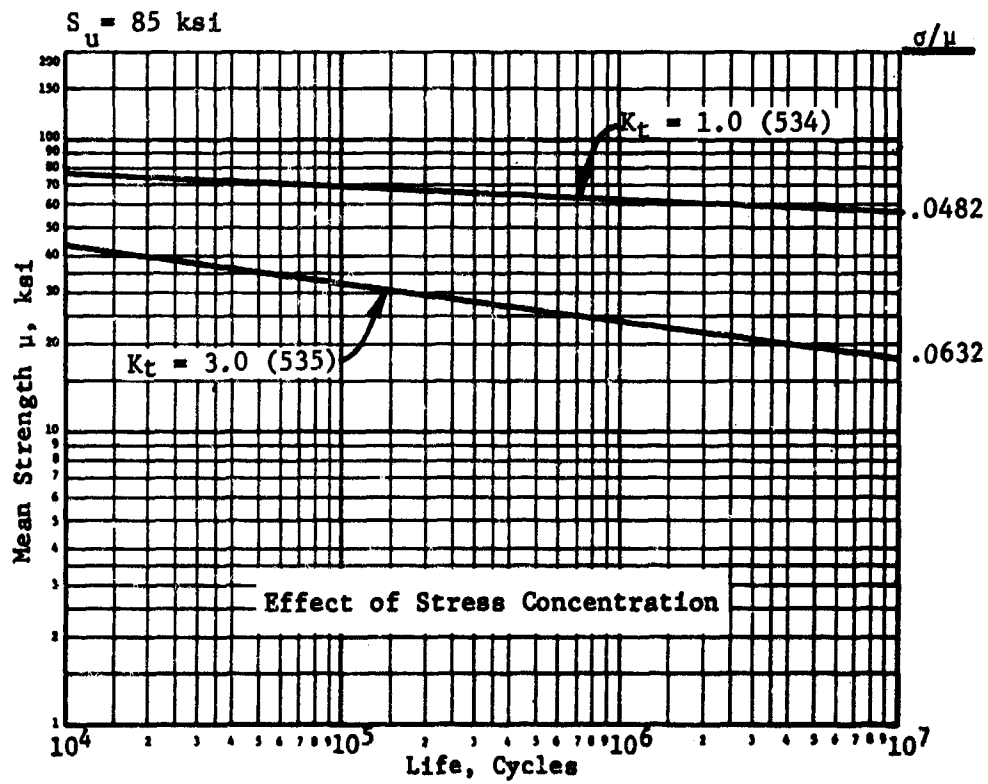

(Numbers in parentheses are the code numbers of the tabulated values.)

Figure 6.42

T1 - .07 N2 - .2 O2 - .2 C

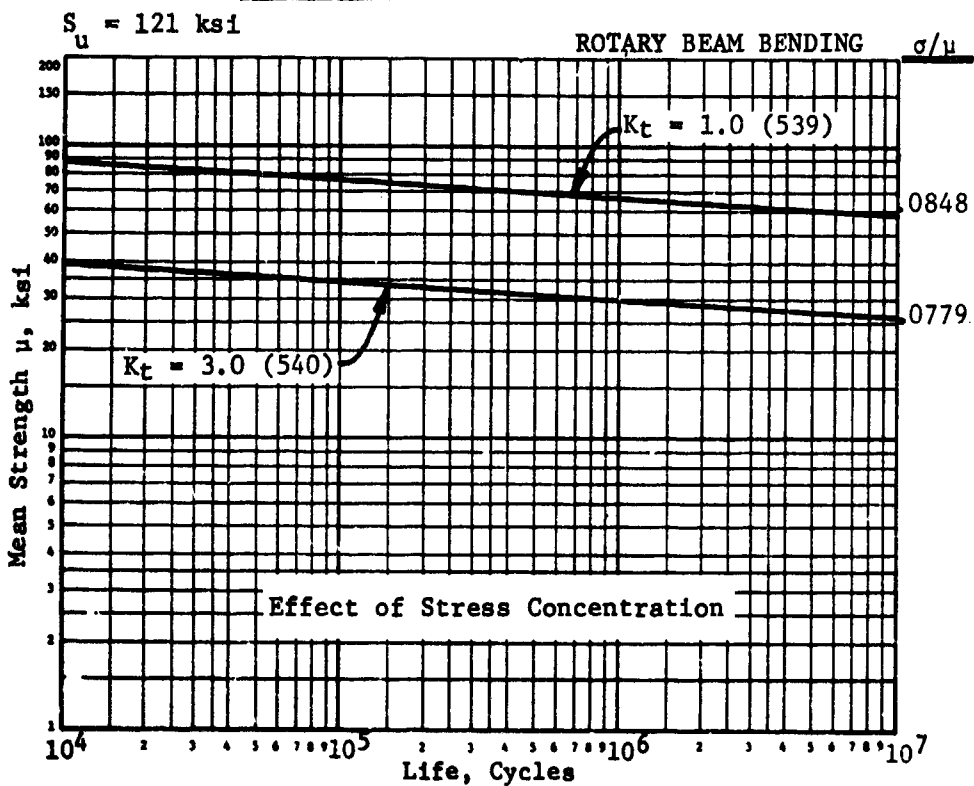

(Numbers in parentheses are the code numbers of the tabulated values.)

Figure 6.43

K-151A CERMET

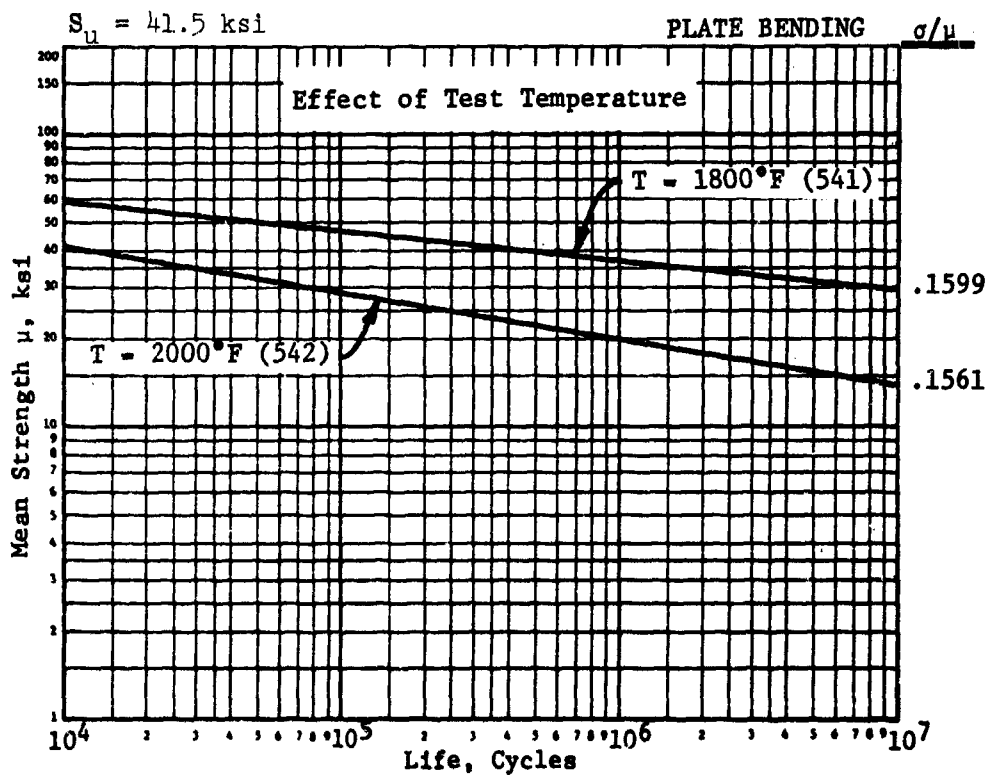

(Numbers in parentheses are the code numbers of the tabulated values.)

Figure 6.44

K-162B CERMET

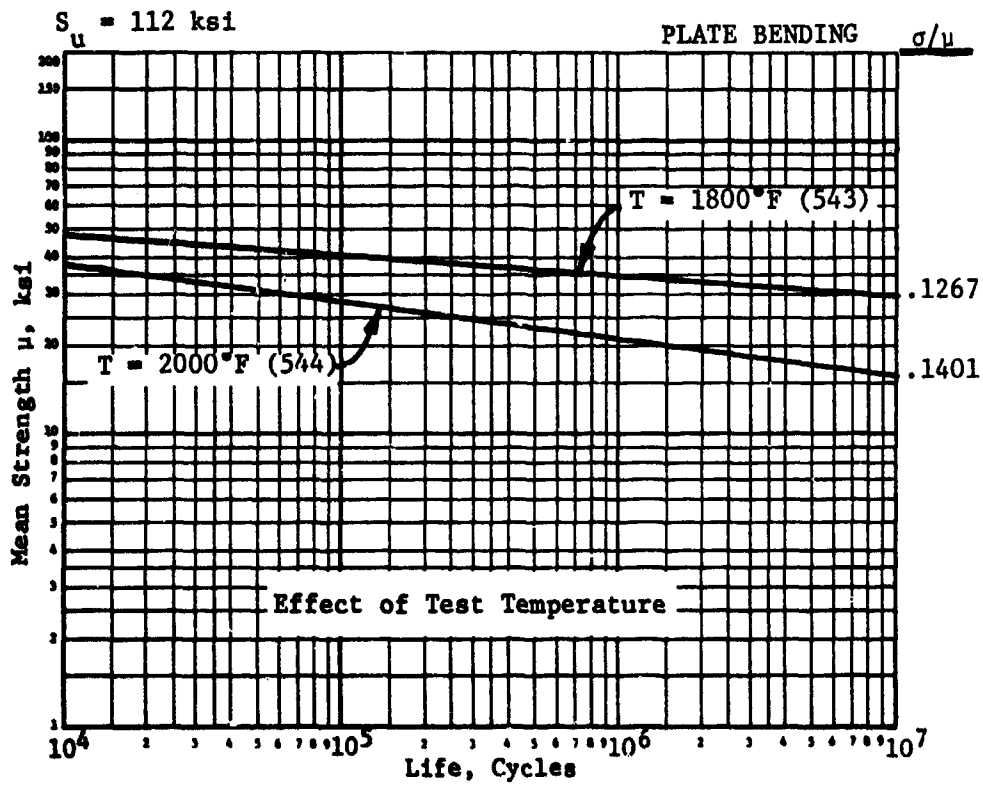

(Numbers in parentheses are the code numbers of the tabulated values.)

Figure 6.45

K-183A CERMET

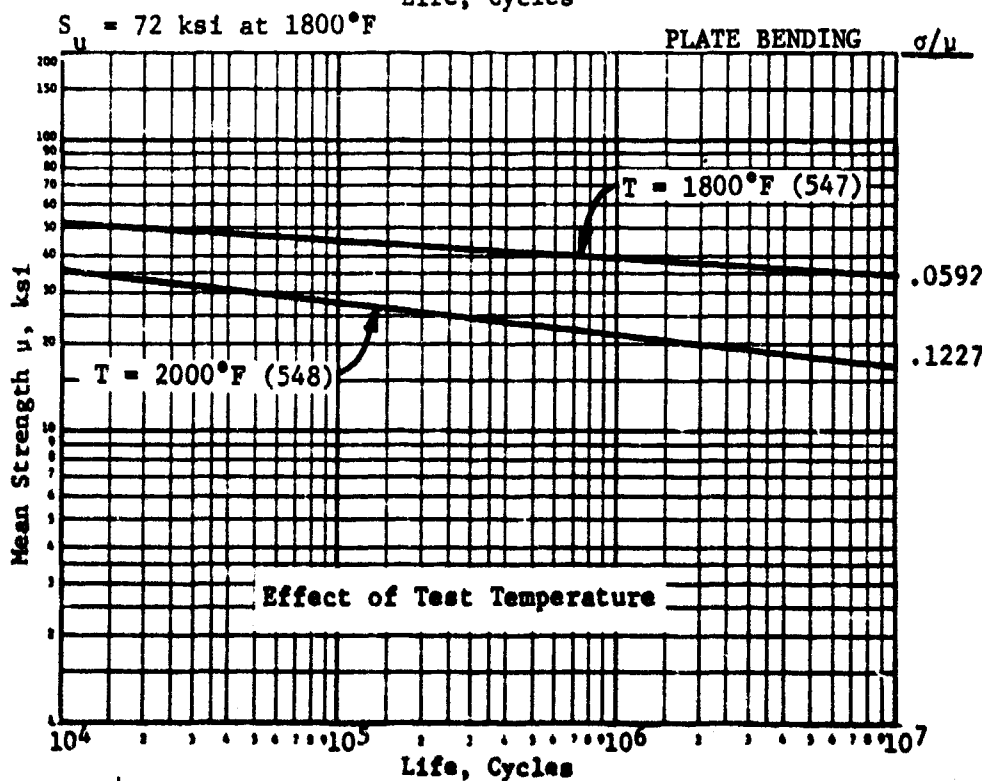
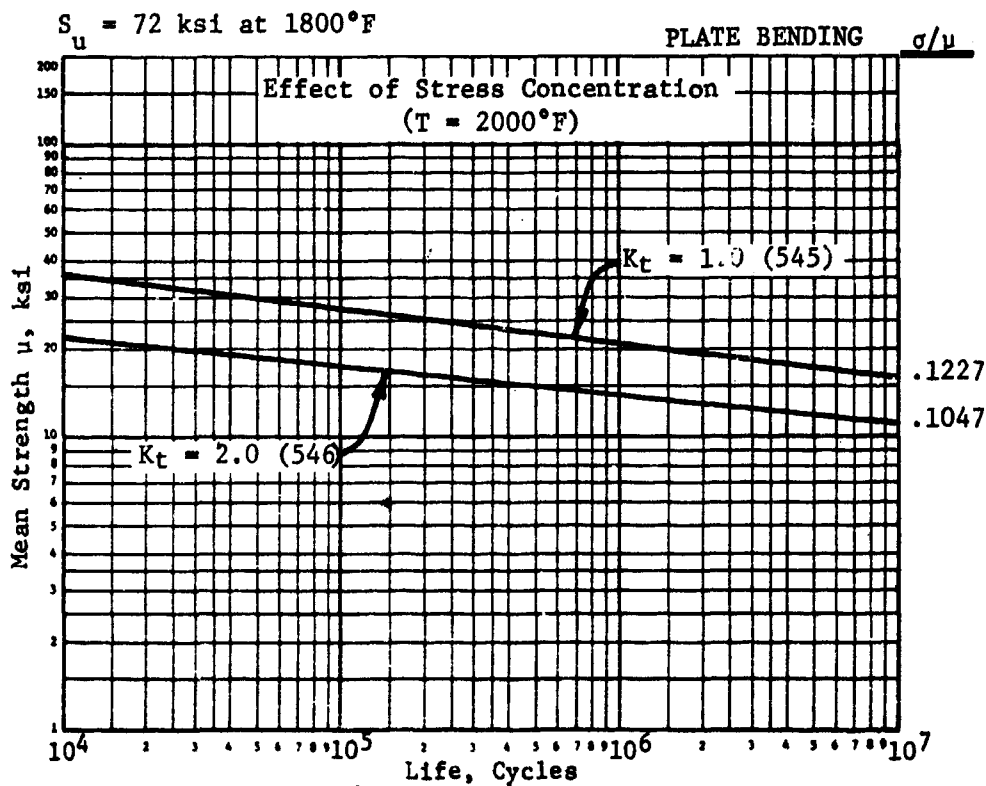

(Numbers in parentheses are the code numbers of the tabulated values.)

Figure 6.46



Ti - 4 Al - 3 Mo - 1 V

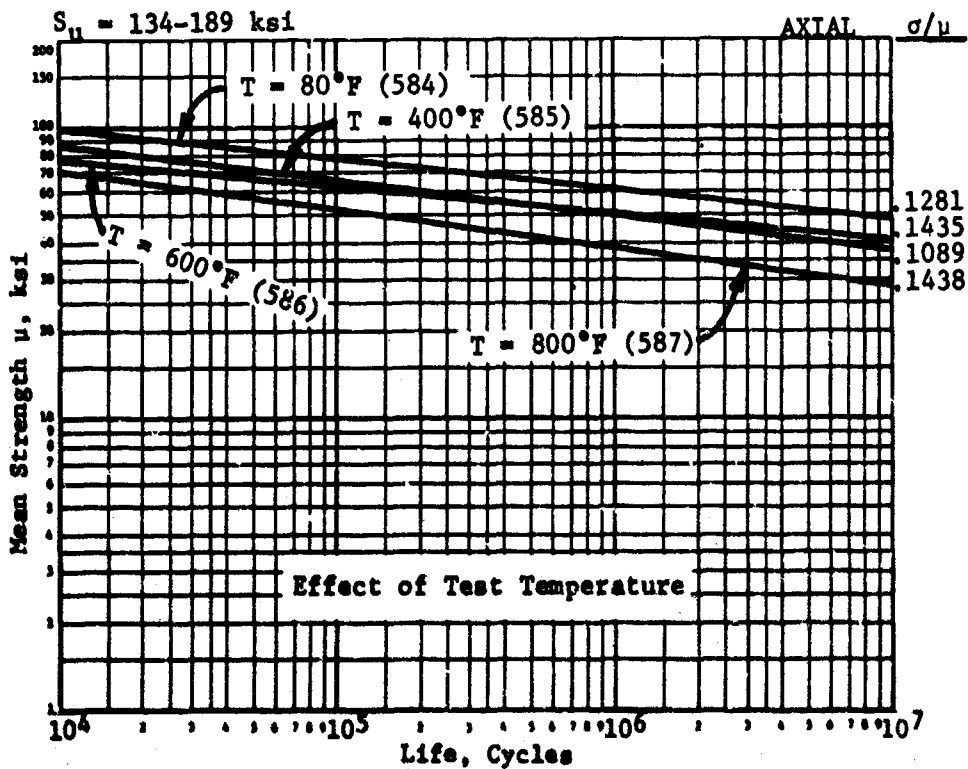
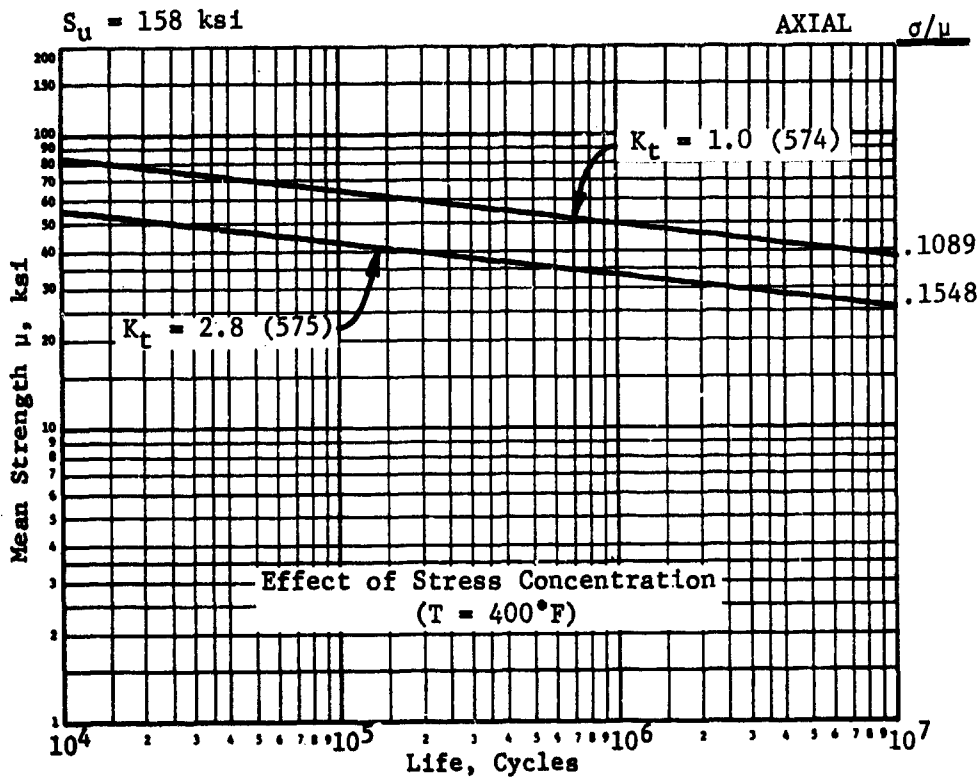

(Numbers in parentheses are the code numbers of the tabulated values.)

Figure 6.47

Ti - 5 Al - 2.5 Sn - .07 N<sub>2</sub>

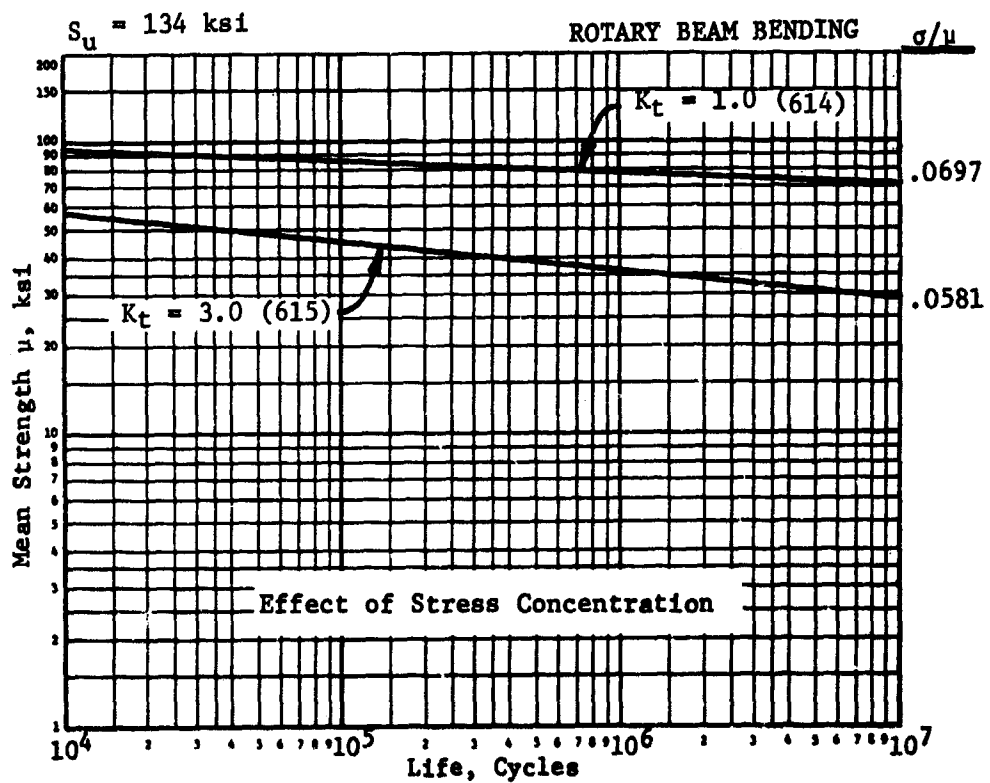

(Numbers in parentheses are the code numbers of the tabulated values.)

Figure 6.48

Ti - 5 Al - 2.5 Sn - .2 O2

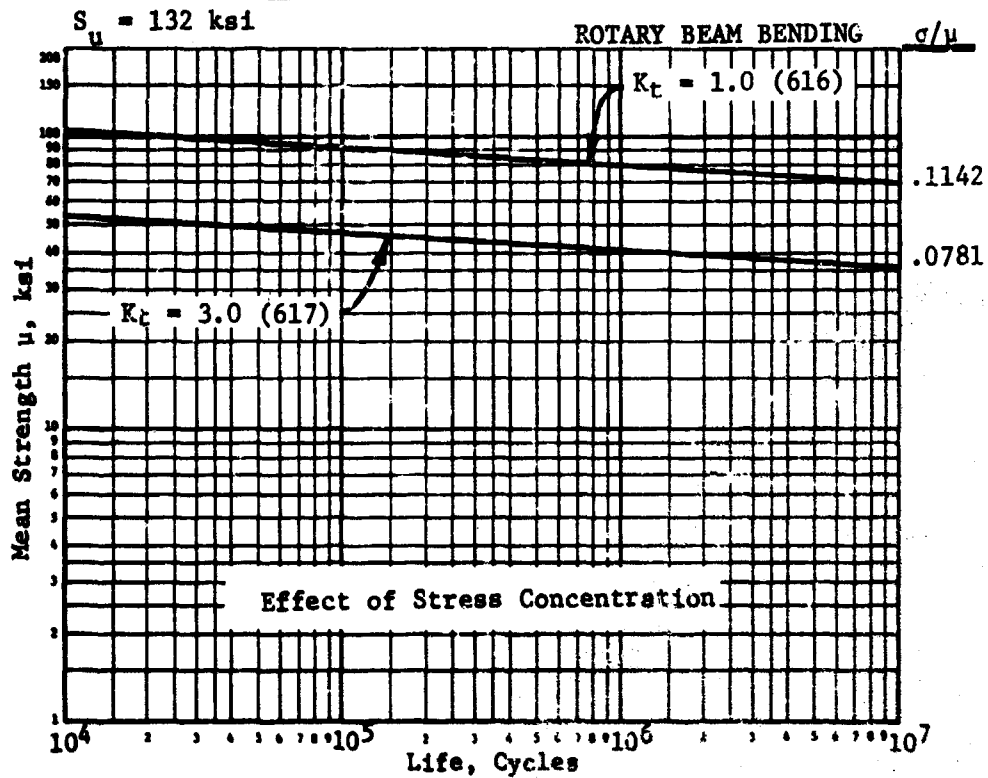

(Numbers in parentheses are the code numbers of the tabulated values.)

Figure 6.49

T1 - 5 Al - 2.5 Sn - .2 C

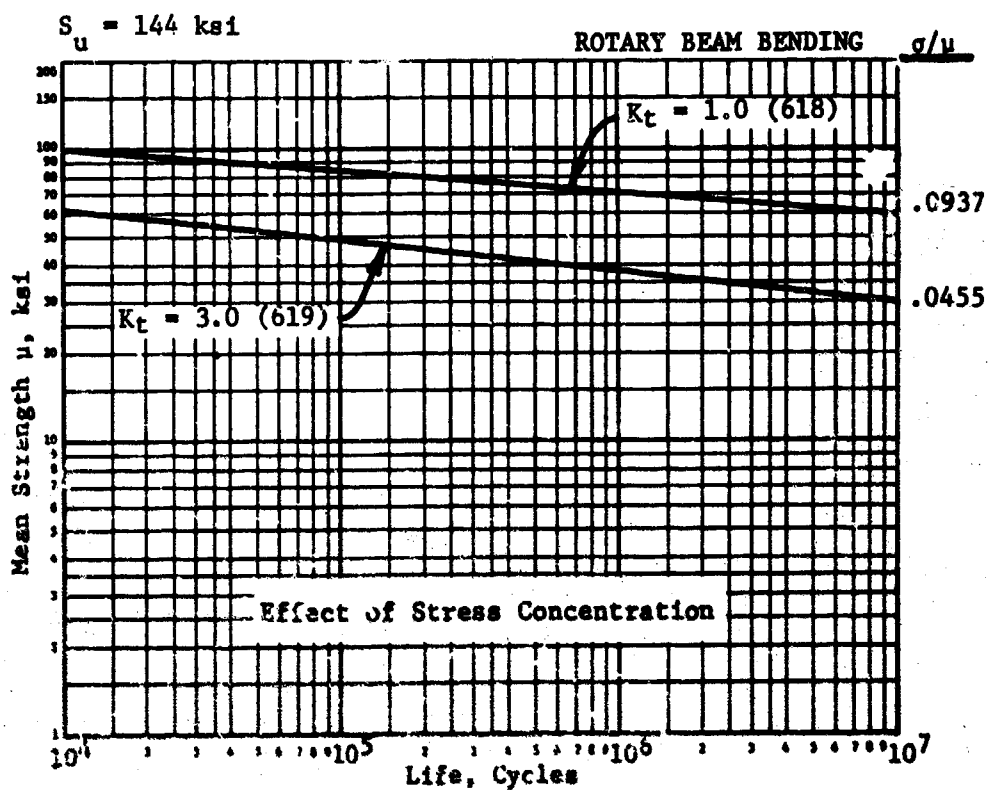

(Numbers in parentheses are the code numbers of the tabulated values.)

Figure 6.50

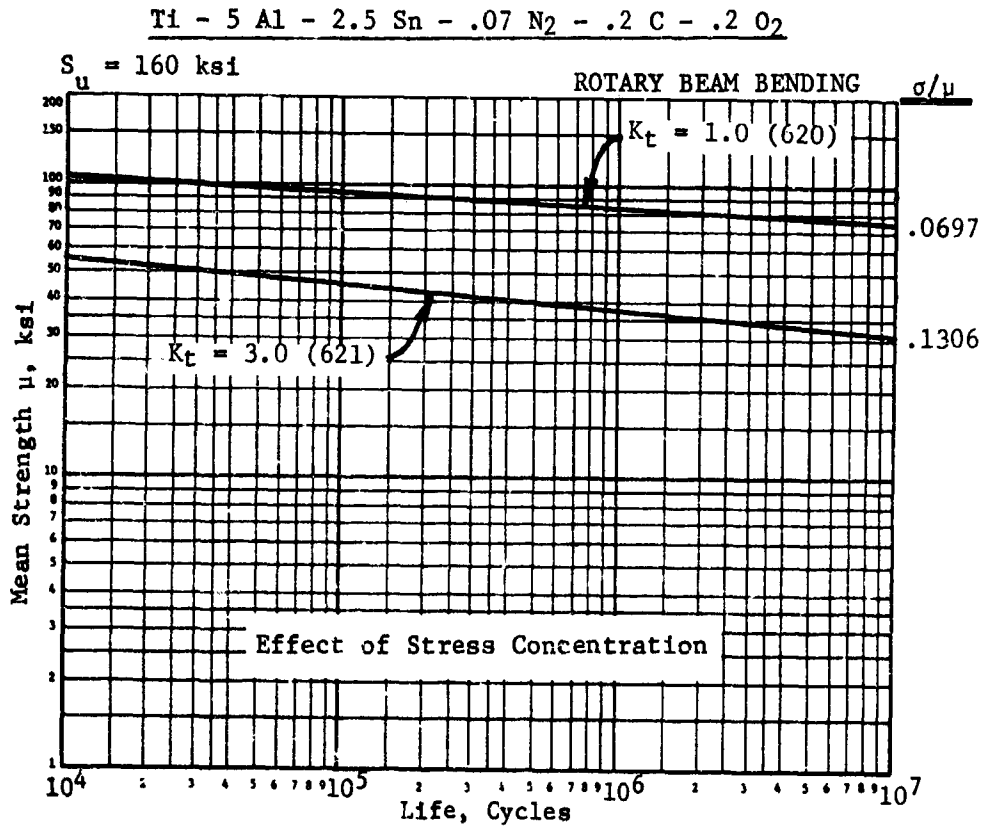

(Numbers in parentheses are the code numbers of the tabulated values.)

Figure 6.51

Ti - 6 Al

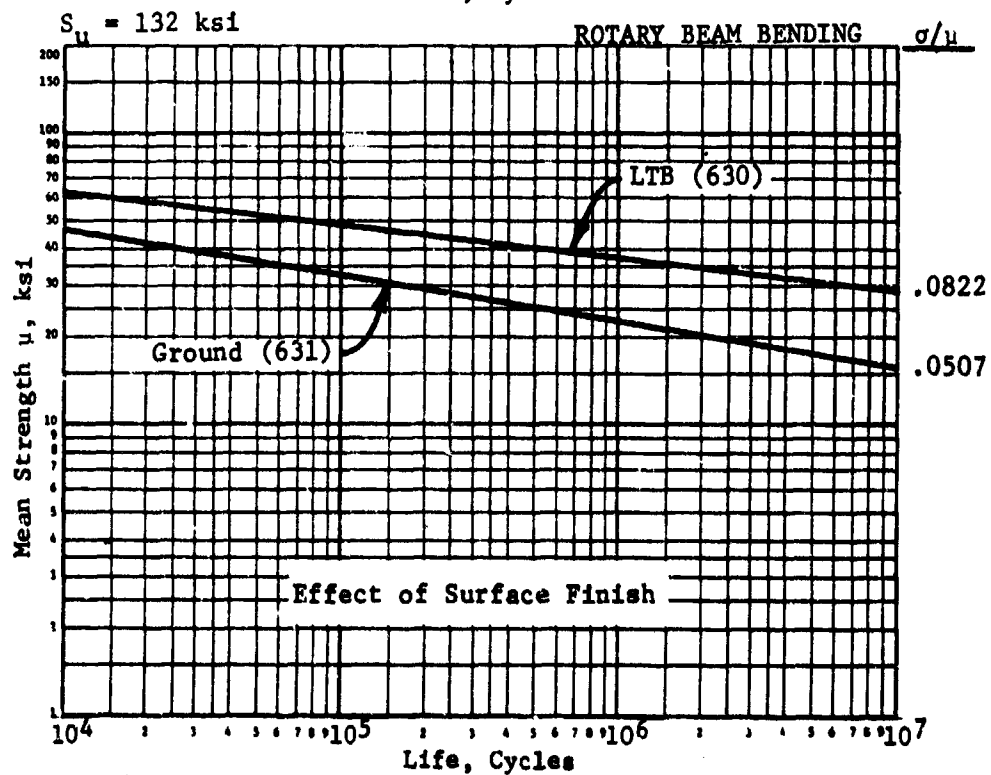
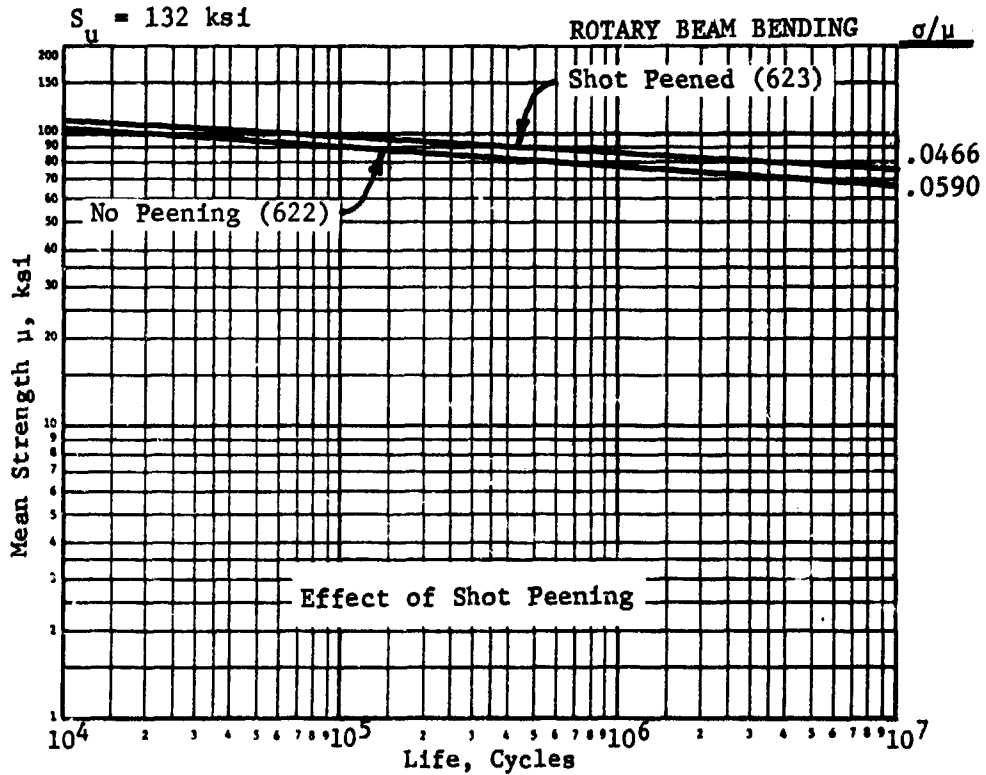

(Numbers in parentheses are the code numbers of the tabulated values.)

Figure 6.52

Ti - 6 Al - 4 V

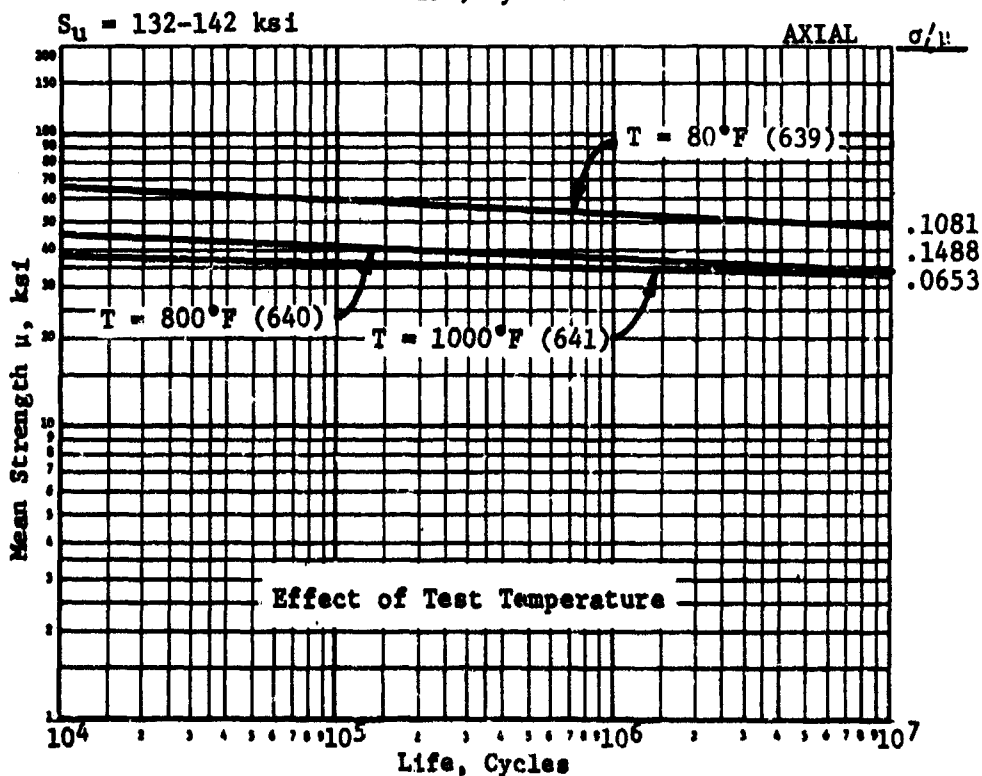
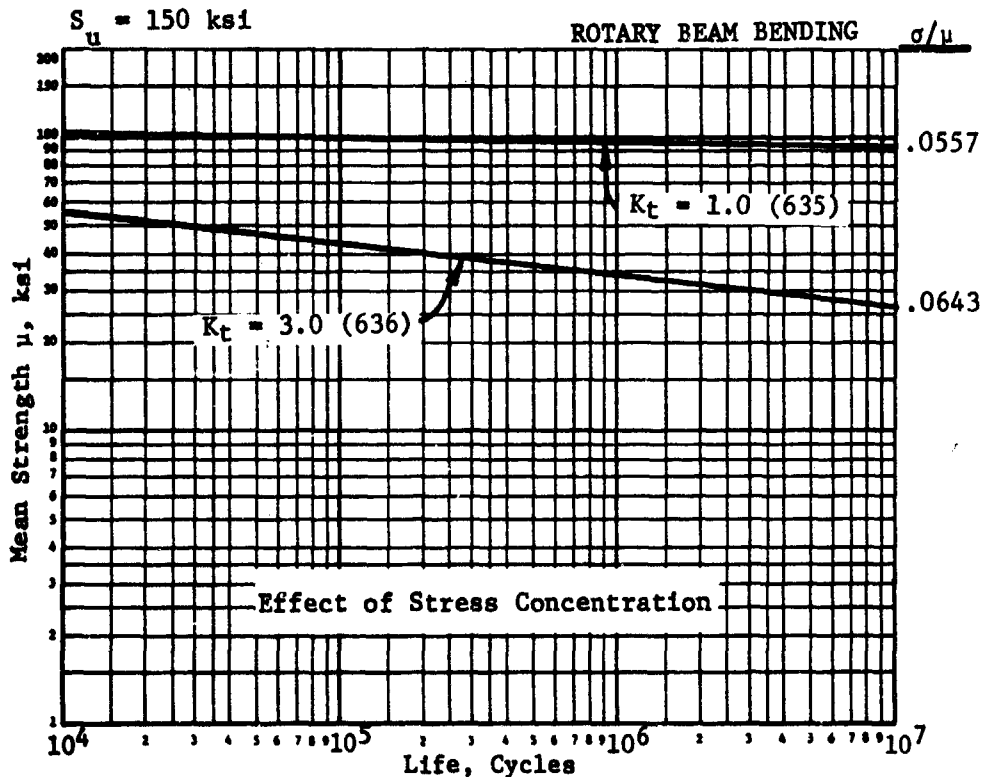

(Numbers in parentheses are the code numbers of the tabulated values.)

Figure 6.53

T1 - 6 Al - 4 V - .07 N<sub>2</sub>

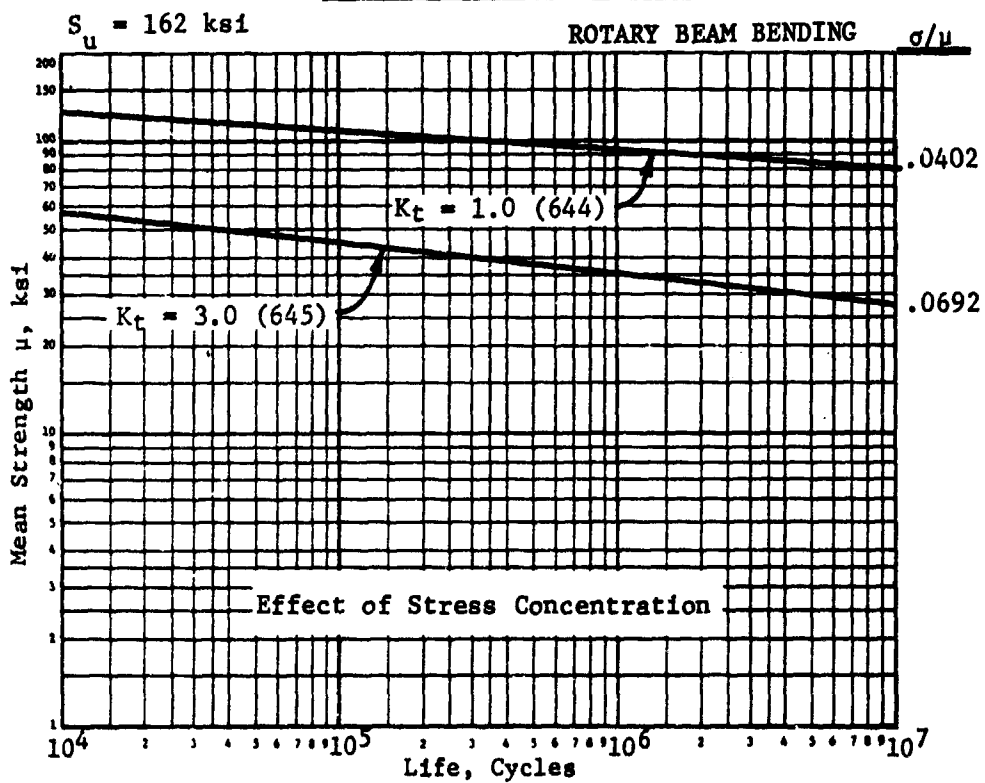

(Numbers in parentheses are the code numbers of the tabulated values.)

Figure 6.54



Ti - 6 Al - 4 V - 0.2 O<sub>2</sub>

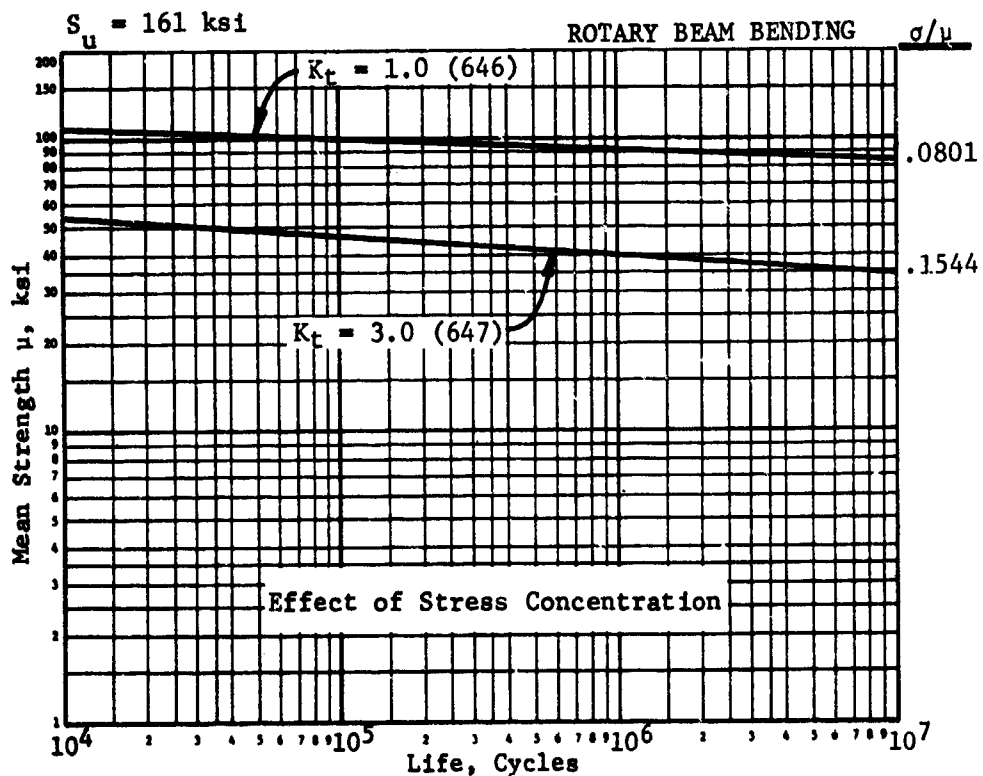

(Numbers in parentheses are the code numbers of the tabulated values.)

Figure 6.55

Ti - 6 Al - 4 V - 0.2 C

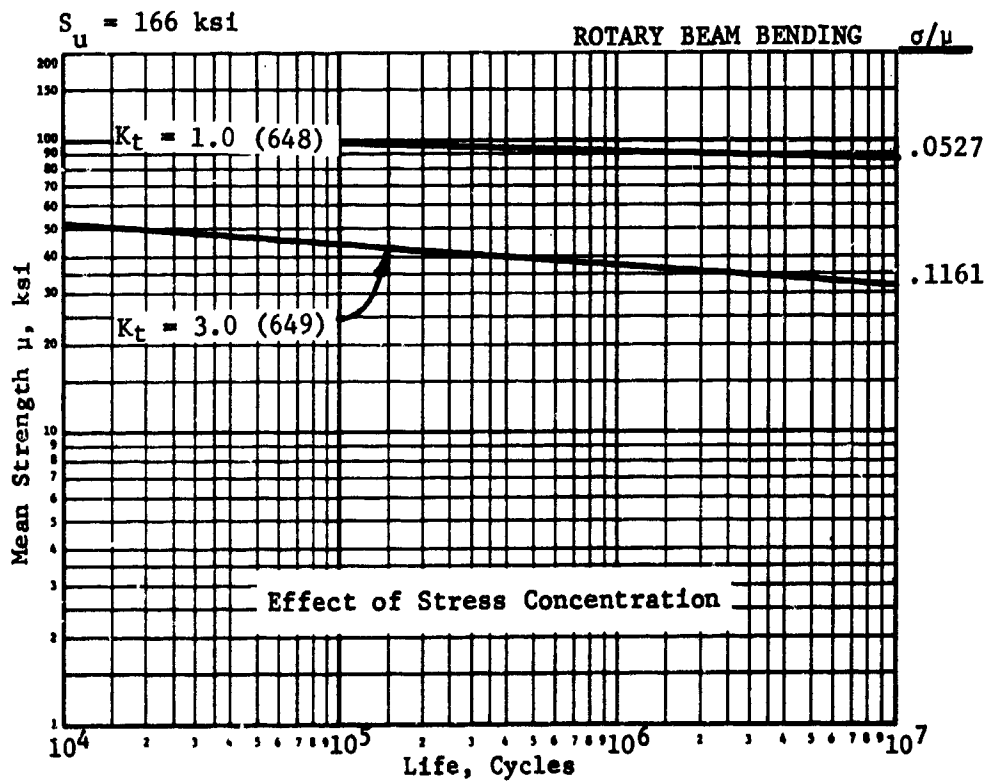

(Numbers in parentheses are the code numbers of the tabulated values.)

Figure 6.56

T1 - 6 Al - 4 V - .07 N2 - .2 O2 - .2 C

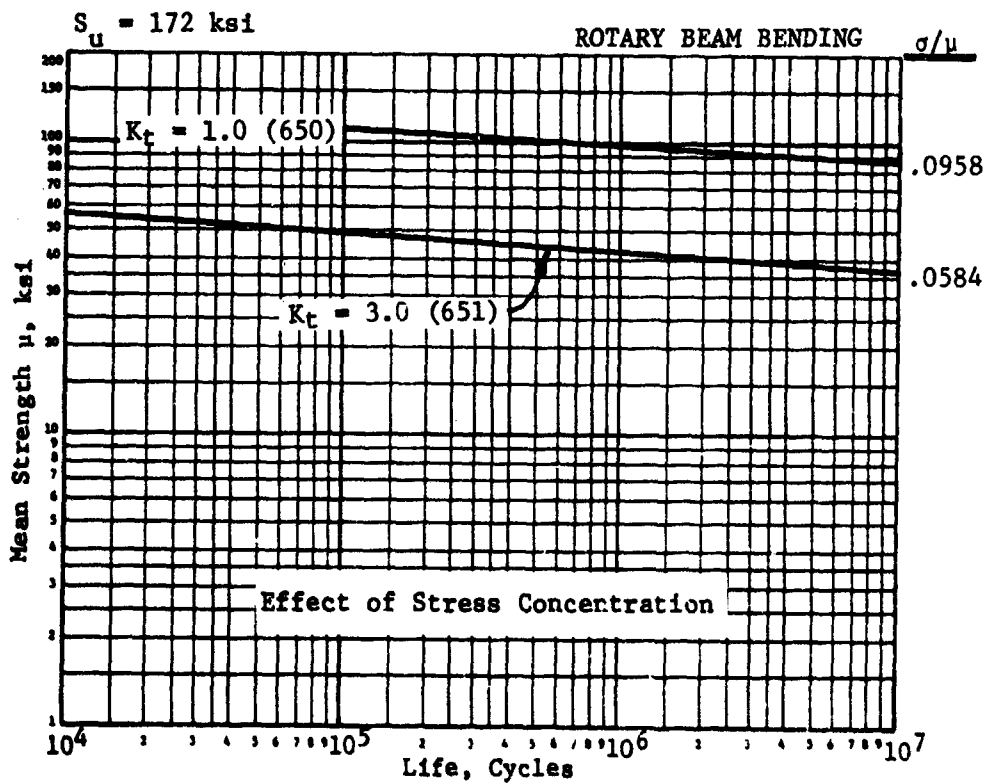

(Numbers in parentheses are the code numbers of the tabulated values.)

Figure 6.57

Ti - 3 Mn - 0.2 O<sub>2</sub>

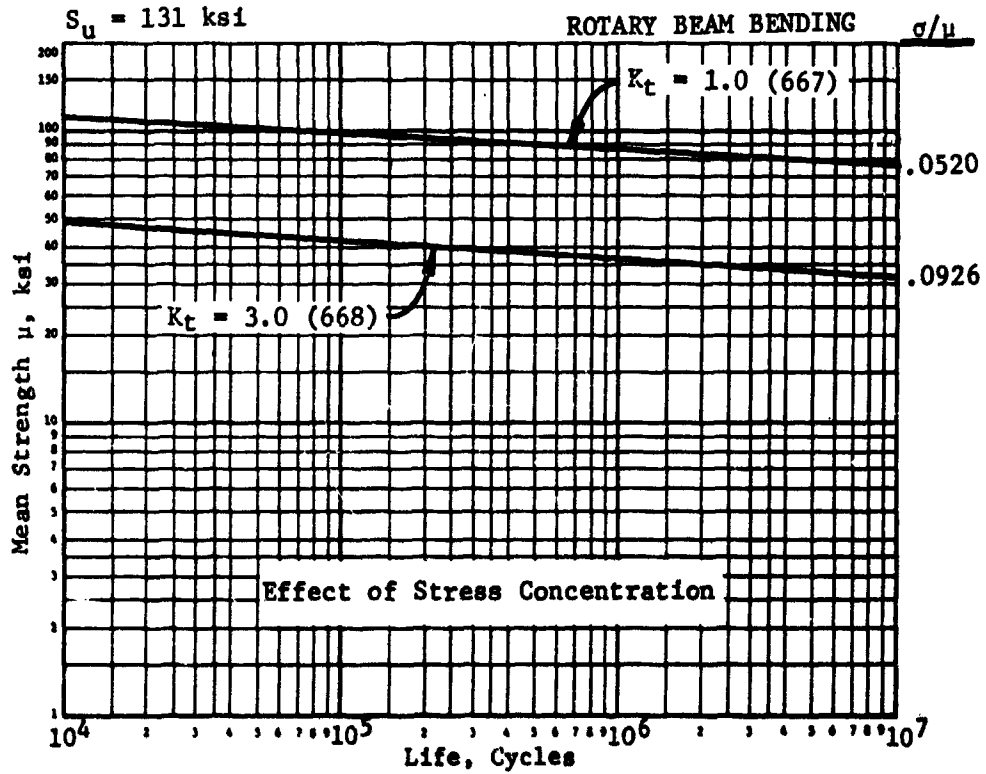

(Numbers in parentheses are the code numbers of the tabulated values.)

Figure 6.58

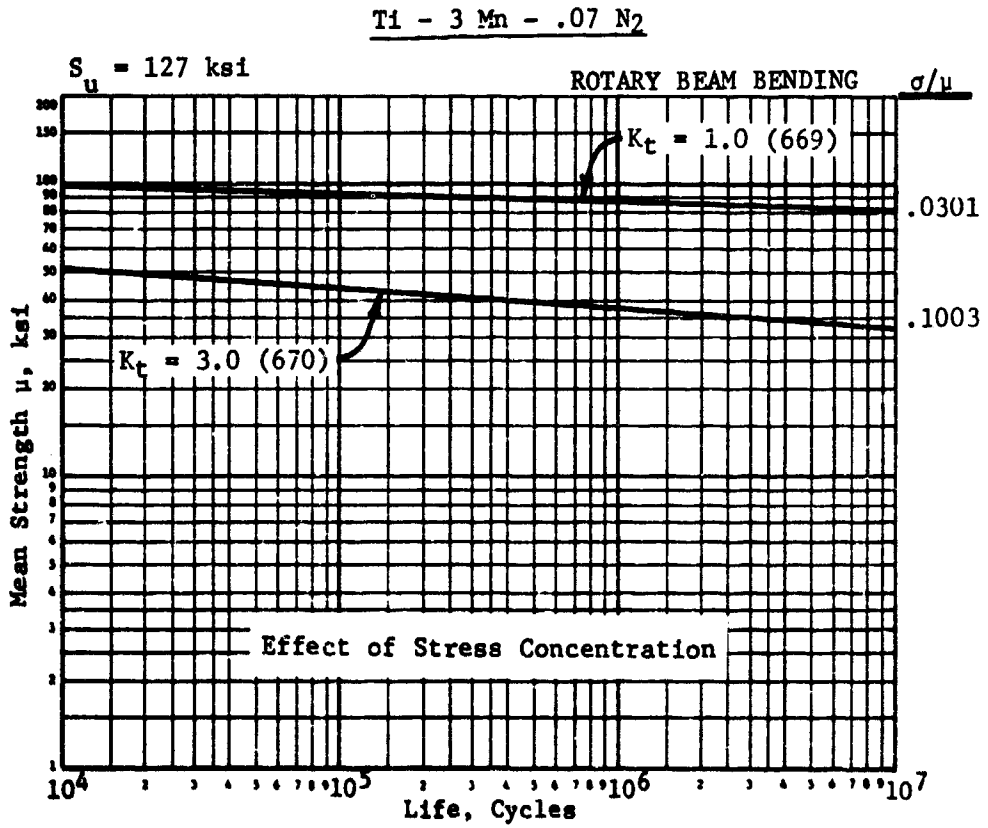

(Numbers in parentheses are the code numbers of the tabulated values.)

Figure 6.59

Ti - 3 Mn - .2 C

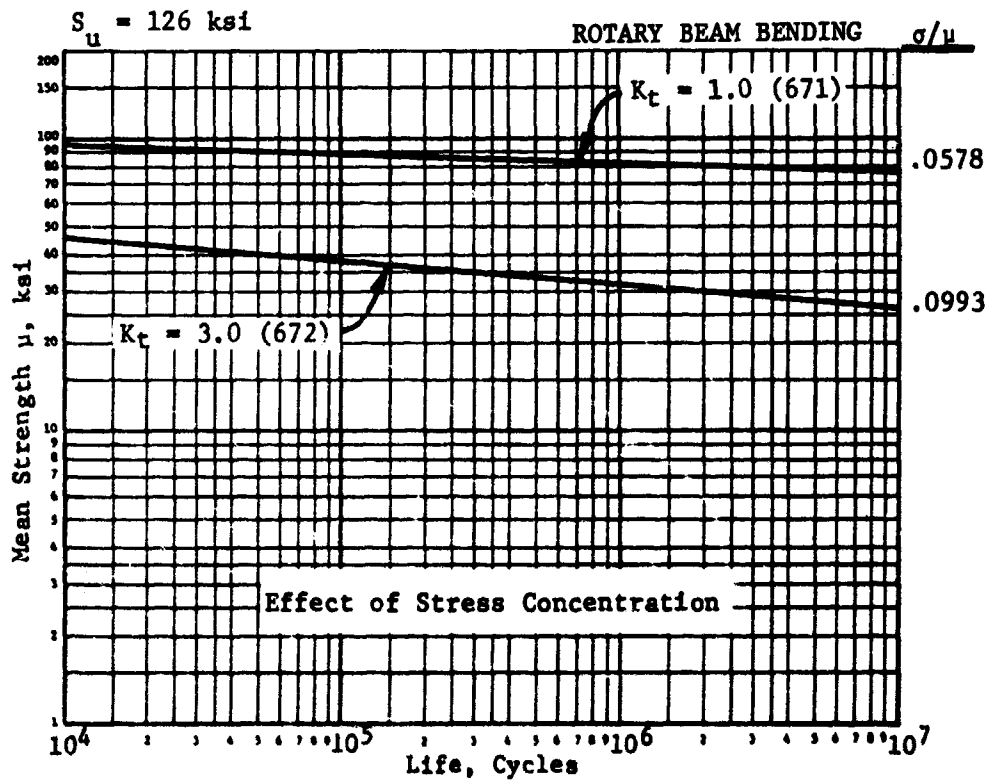

(Numbers in parentheses are the code numbers of the tabulated values.)

Figure 6.60

T1 - 3 Mn COMPLEX

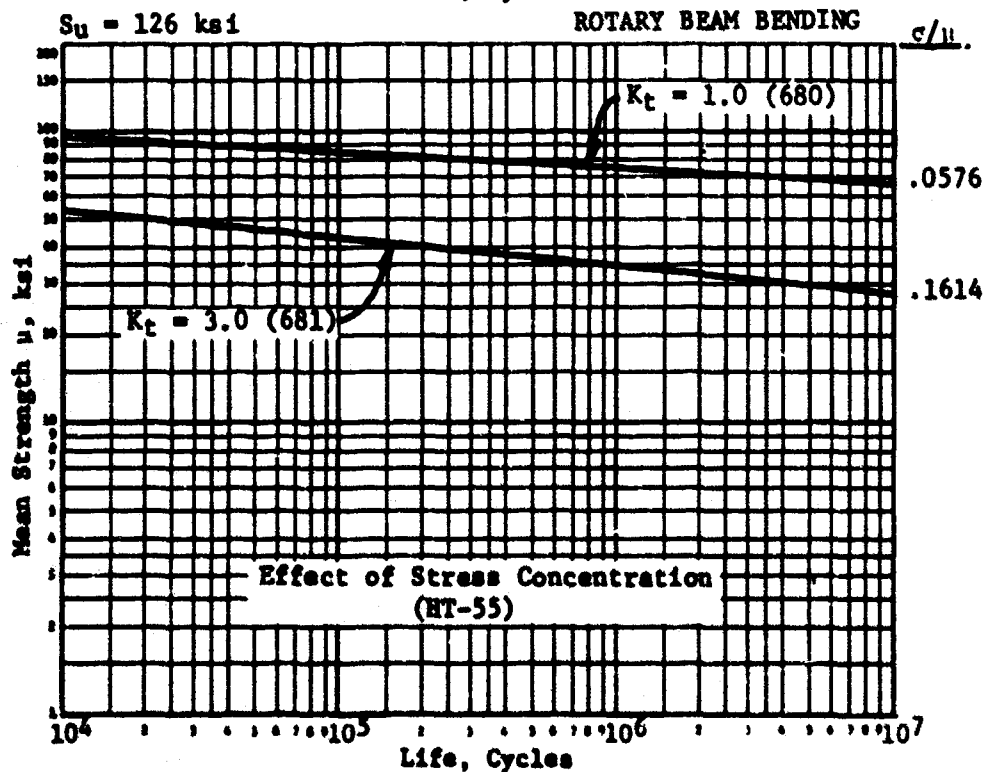
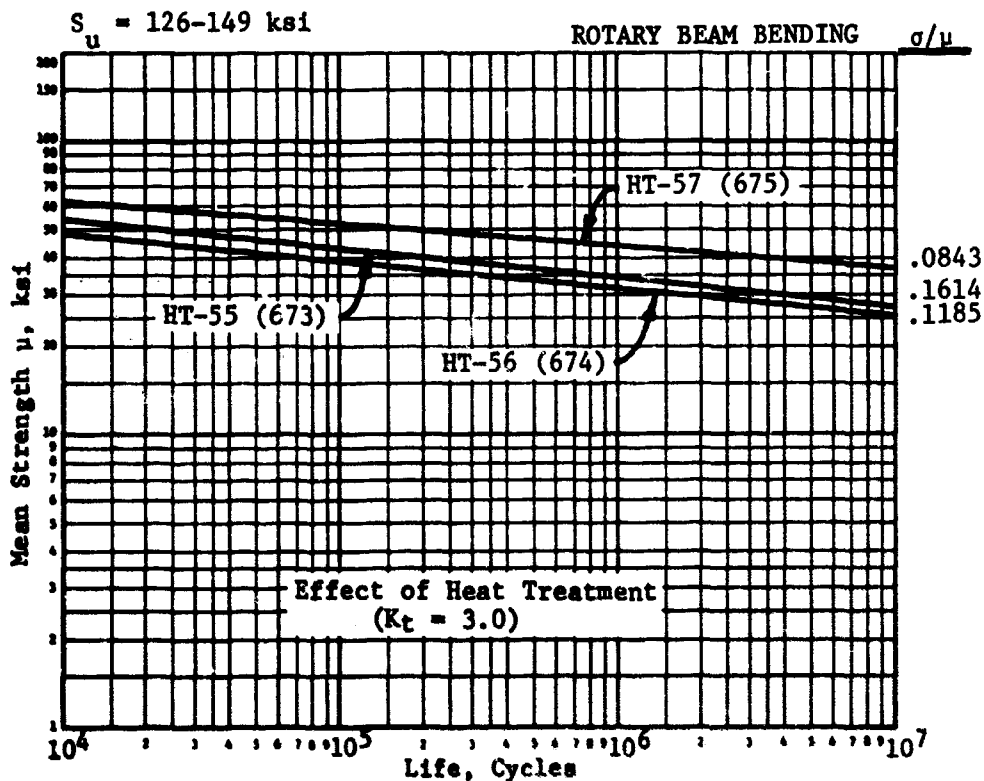

(Numbers in parentheses are the code numbers of the tabulated values.)

Figure 6.61

T1 - 8 Mn

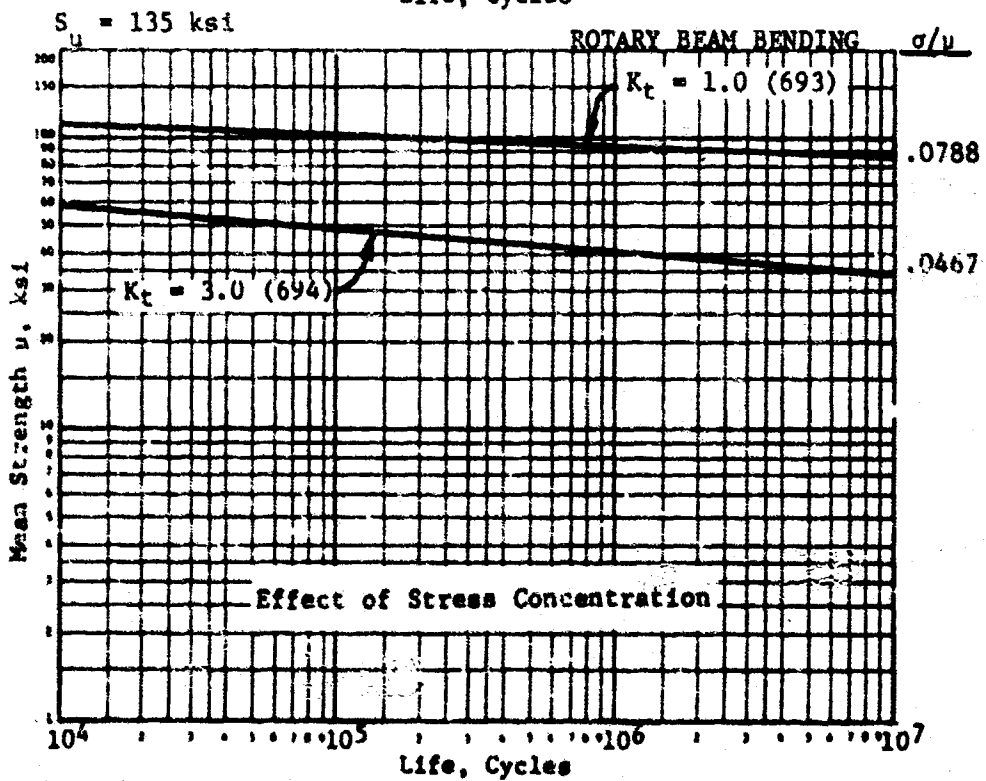
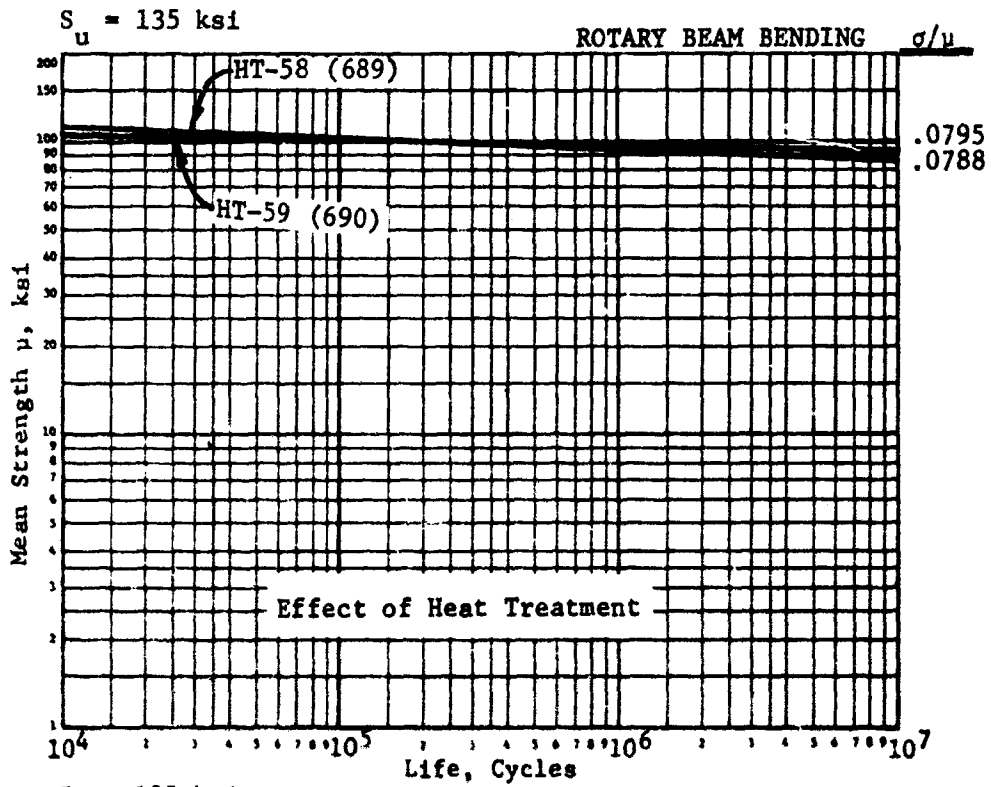

(Numbers in parentheses are the code numbers of the tabulated values.)

Figure 6.62



T1 - 13 V - 11 Cr - 3 Al

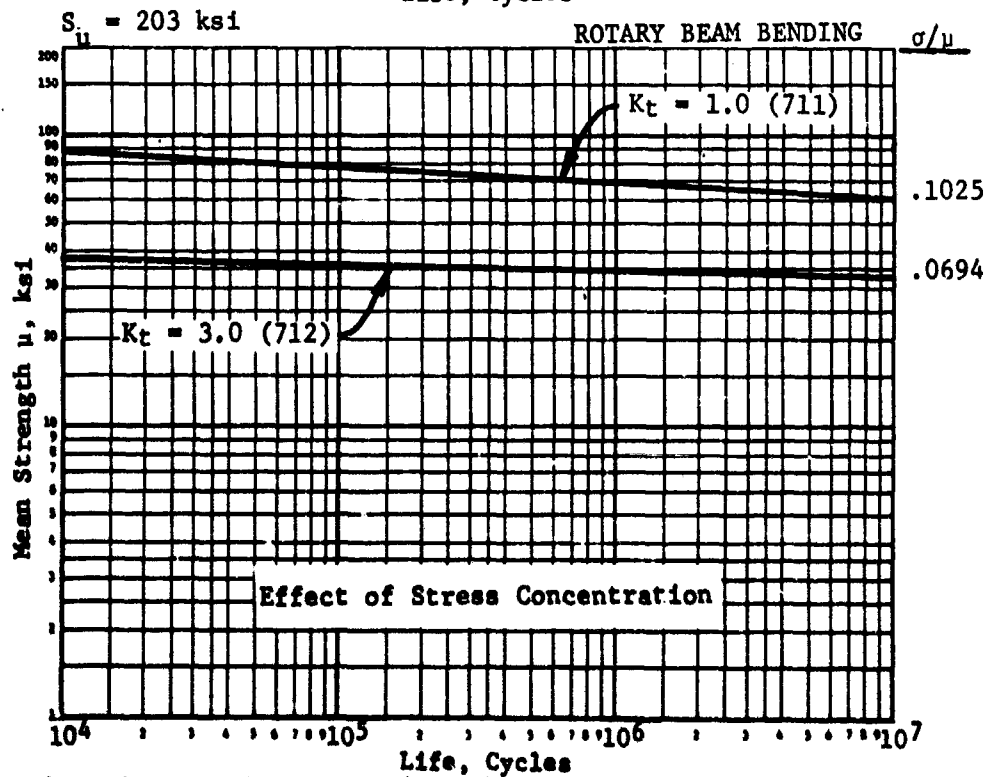
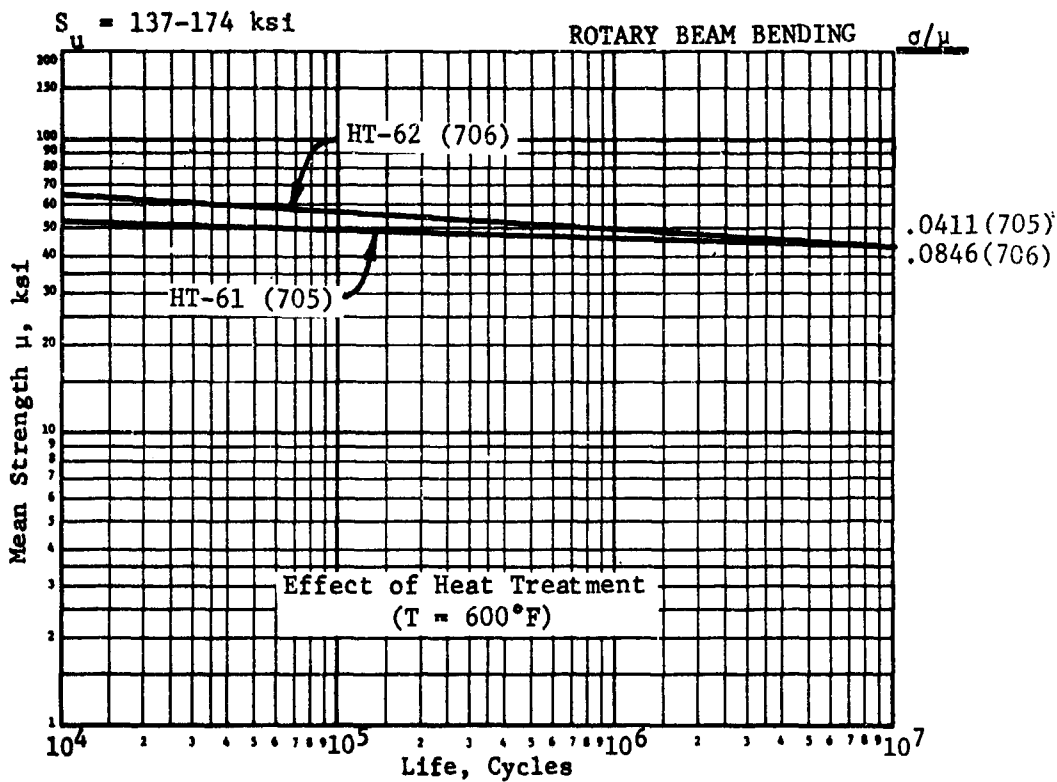

(Numbers in parentheses are the code numbers of the tabulated values.)

Figure 6.63

Ti - 16 V - 2.5 Sn

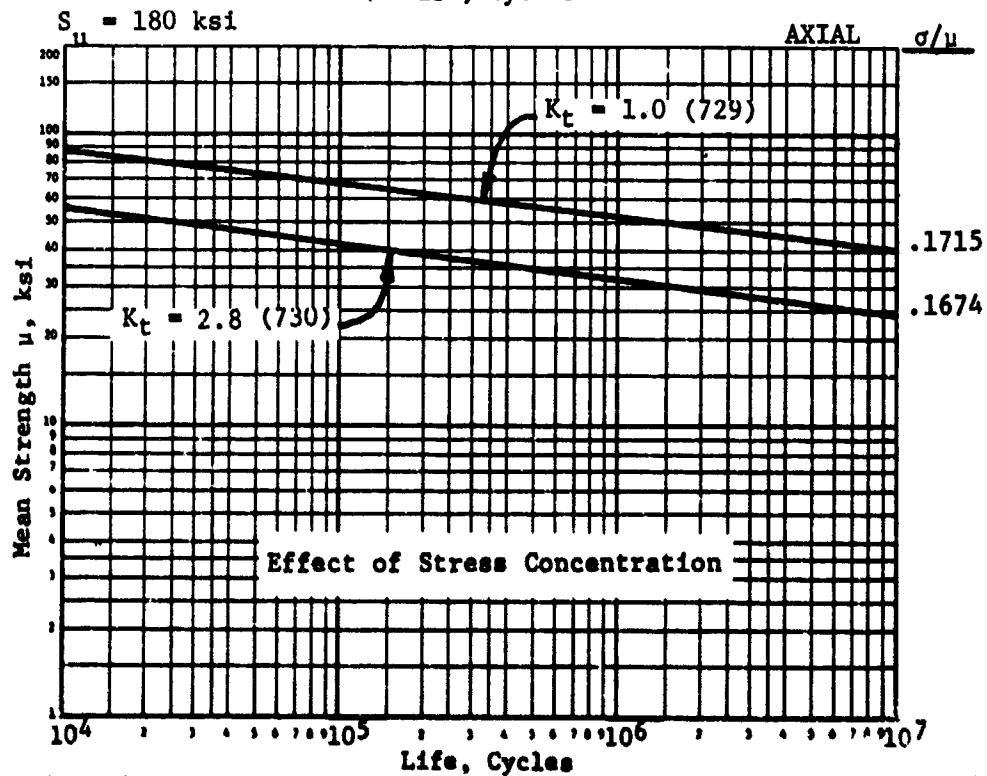
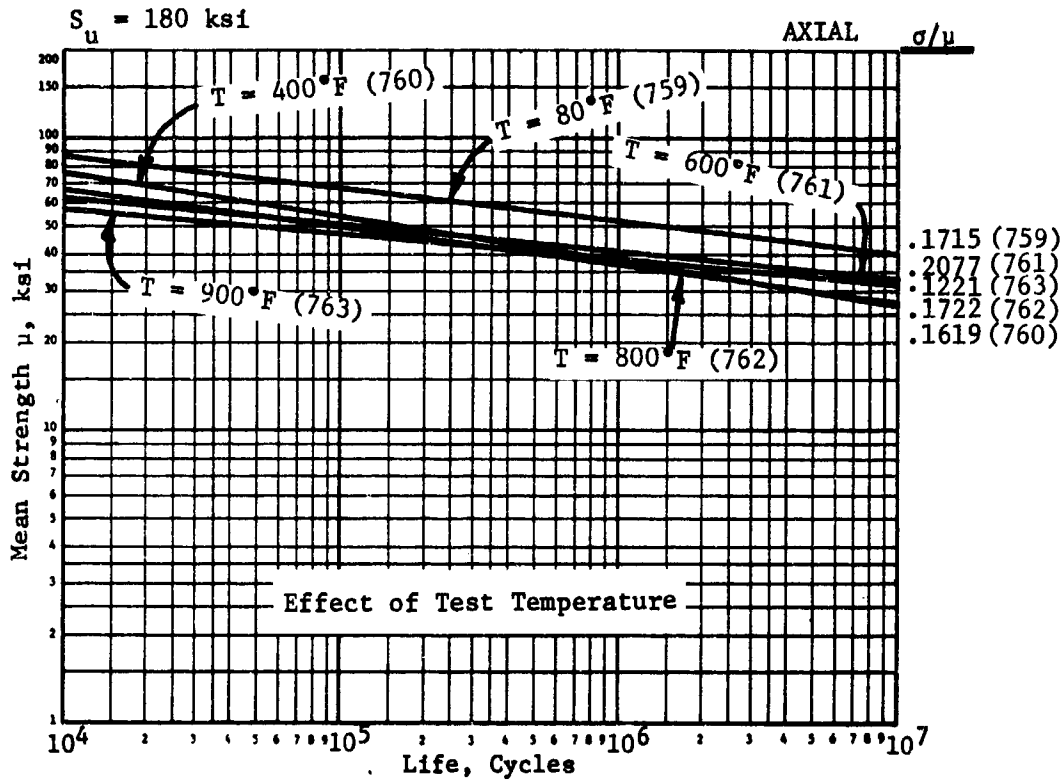

(Numbers in parentheses are the code numbers of the tabulated values.)

Figure 6.64

## SECTION 7 THE STATISTICAL DISTRIBUTION OF STRESS

## 7.1. STRESS SPECTRUM VS STRESS DISTRIBUTION

The problem of stress distribution in the Interference Theory appears to be much more involved than the problem of strength distribution. Consider, for example, the problem of an aluminum cylinder head in a reciprocating engine. Because of the variation in hardness, surface finish, etc., the fatigue strength will vary from one cylinder head to another. This will result in a distribution curve in which the strength will be plotted on the abscissa and the number of cylinder heads having a given strength (i.e., frequency of occurrence) on the ordinate.

Consider now the stress distribution in the cylinder heads. The stresses in the head result from the gas pressure loading. If the attention is now focussed on a single cylinder head, then the variation in the gas pressure will produce a distribution of stresses in this particular head. The resultant curve will be a plot of the stresses in the head on the abscissa and the number of times that this stress occurs in this particular head on the ordinate [Figure 7.1 (a)].

This, however, is not what is wanted in the application of the Interference Theory, because this distribution of stresses cannot be matched with the distribution of strength. In the strength distribution the ordinate gives the number of cylinder heads having a given strength. Therefore, in the stress distribution the ordinate must be the number of cylinder heads having a given stress (and not the number of times a given stress occurs in a single head). This can be obtained by considering the fact that different engines will be subjected in service to different operating conditions, and therefore, the distribution of gas pressure loading will vary from engine to engine. As pointed out in Section 7.2, a spectrum of stresses must be converted to an equivalent stress for the purpose of Interference Theory. Therefore, if a spectrum of loading due to different service conditions varies from engine to engine, in a population of cylinder heads, the equivalent stress will vary from head to head. Thus the statistical stress distribution desired for the Interference Theory may be obtained [Figure 7.1 (b)]. In this distribution the equivalent stress will be plotted on the abscissa and the number of cylinder heads (frequency of occurrence) having that stress on the ordinate. This distribution then can be compared with the strength distribution to obtain the probability of Interference.

7.2 CONVERSION OF A STRESS SPECTRUM TO AN EQUIVALENT STRESS ( $S_{equ}$ )

By definition, the equivalent stress is a completely reversed stress of constant amplitude which, when imposed on a part, should cause failure at the same life as if the stress spectrum was imposed instead. Thus, the damage accumulated at any given life, due to this equivalent stress, will be the same as if due to the spectrum of stresses.

The first step towards converting the spectrum to a single stress ( $S_{equ}$ ) is to convert the operating stresses, which may have some mean stress associated with them, to zero mean stress, that is, to a completely reversed stress.

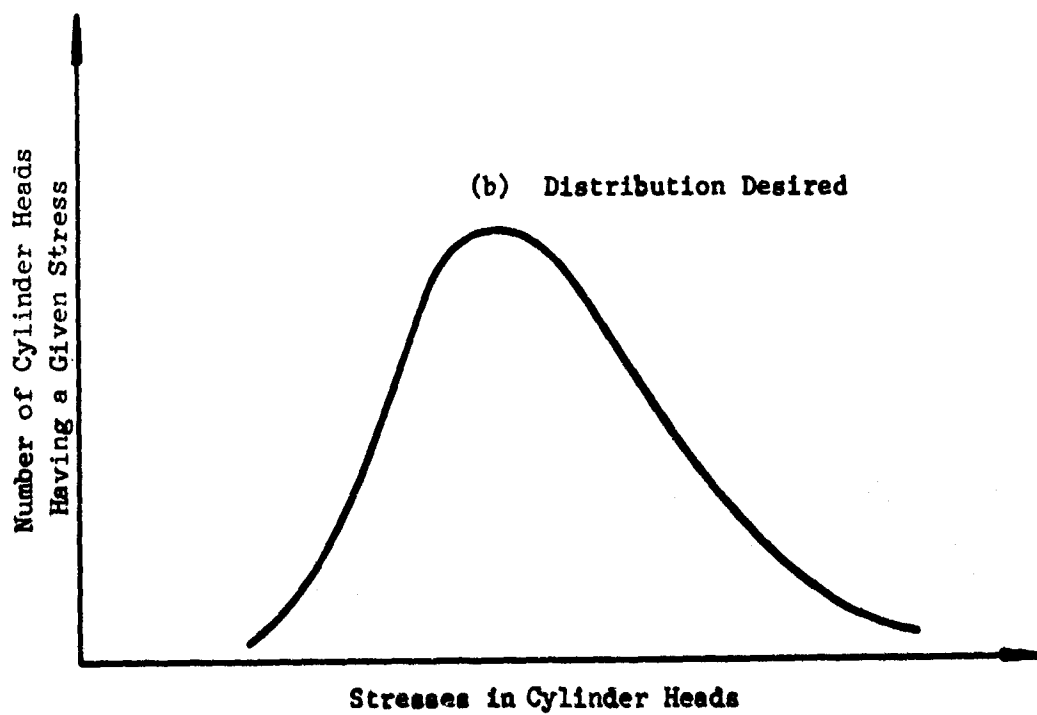
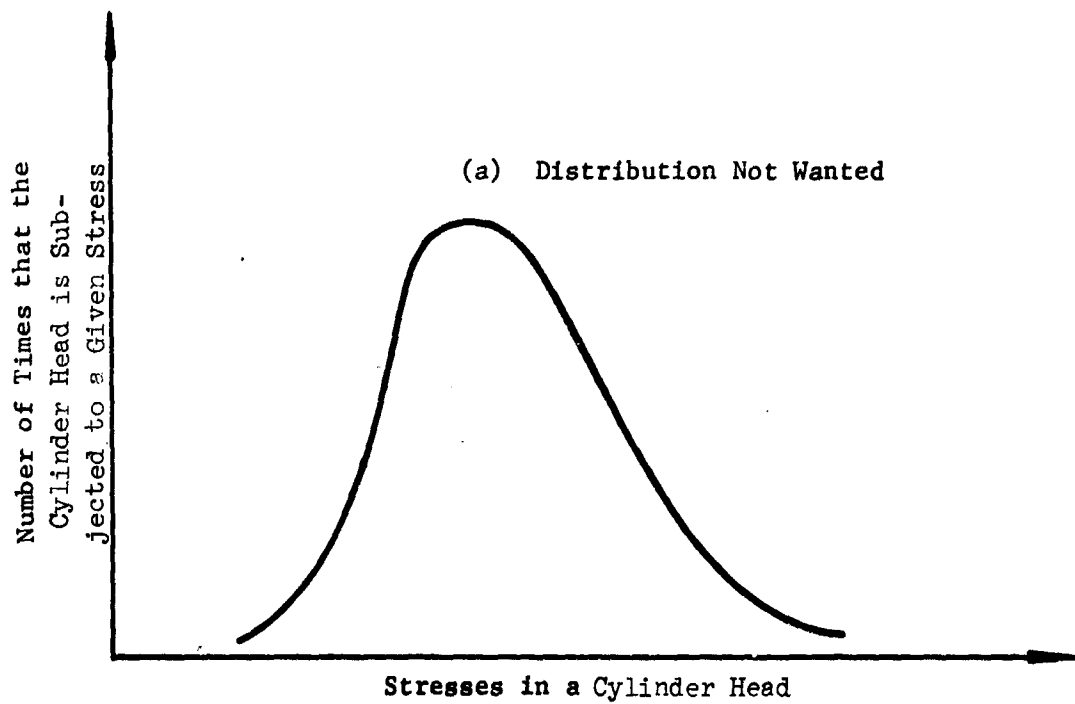

Figure 7.1 Stress Distribution for the Interference Theory

(Figure 7.2). This can be done by means of the modified Goodman diagram. Draw the Goodman diagram as shown in Figure 7.3. From the spectrum of operating stresses plot each stress cycle on this diagram as shown, for example, line AB. Connect CA and CB and extend to the vertical line where the mean stress is equal to zero. Hence, XY is the zero mean stress equivalent to AB. After reducing all such stress cycles to zero mean stress, the stress spectrum will have all the stress cycles completely reversed. The magnitude of XY will be different for different stress cycles. Therefore, the original operating stress spectrum [Figure 7.2 (a)], with various mean stress levels, is thus reduced to a stress spectrum with zero mean stress, that is, to a completely reversed stress (Figure 7.4).

This spectrum can then be reduced to a single equivalent stress of constant amplitude by means of Miner's or Corten-Dolan's Rule.

### 7.2.1 Miner's Rule

Miner's Rule<sup>(10)</sup> assumes that the total life of a component can be estimated by simply adding the fraction of life consumed by each over-stress cycle. Overstress can be defined as the stress above the endurance limit of the material which, if applied, will damage the part. This rule is expressed as:

$$\frac{n_1}{N_1} + \frac{n_2}{N_2} + \frac{n_3}{N_3} + \dots + \frac{n_k}{N_k} = 1$$

or

$$\sum_{i=1}^{i=k} \frac{n_i}{N_i} = 1 \quad (7.1)$$

where  $n_1, n_2, n_3 \dots n_k$  represent the number of cycles at specific overstress levels;  $N_1, N_2, N_3 \dots N_k$  the life cycles to failure at these levels as read from the S-N curve, and  $\sum \frac{n_i}{N_i}$  is the fraction of the total life consumed by  $\sum n_i$  cycles.

The equivalent life (the total life) of a part ( $N_{equ}$ ) under a spectrum of stresses may be found by proportion:

$$\frac{N_{equ}}{1} = \frac{\sum_{i=1}^{i=k} n_i}{\sum_{i=1}^{i=k} \frac{n_i}{N_i}}$$

Suppose, for example, there are three stress levels, 90, 70, and 50 ksi, in a given spectrum. With reference to the curve in Figure 7.5,  $1/(6 \times 10^4)$  is the fraction of life consumed by each 90 ksi stress cycle,  $1/(5 \times 10^5)$  by each 70 ksi cycle,  $1/(8 \times 10^5)$  by each 55 ksi cycle, etc. Using Equation (7.2):

$$N_{equ} = \frac{1 + 1 + 1}{\frac{1}{6 \times 10^4} + \frac{1}{5 \times 10^5} + \frac{1}{8 \times 10^5}} = 1.5 \times 10^5 \text{ cycles}$$

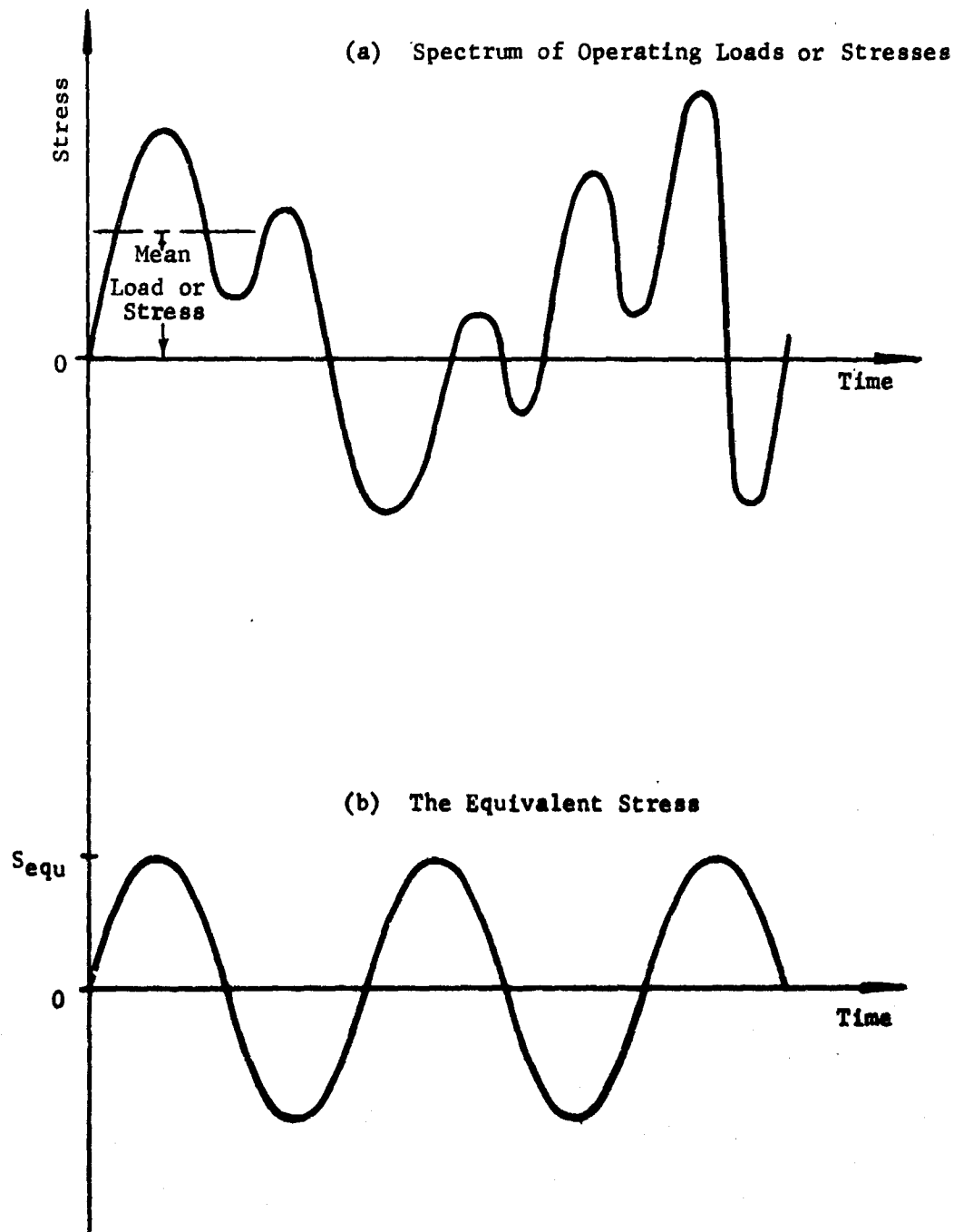

Figure 7.2 Conversion of a Stress Spectrum to An Equivalent Stress

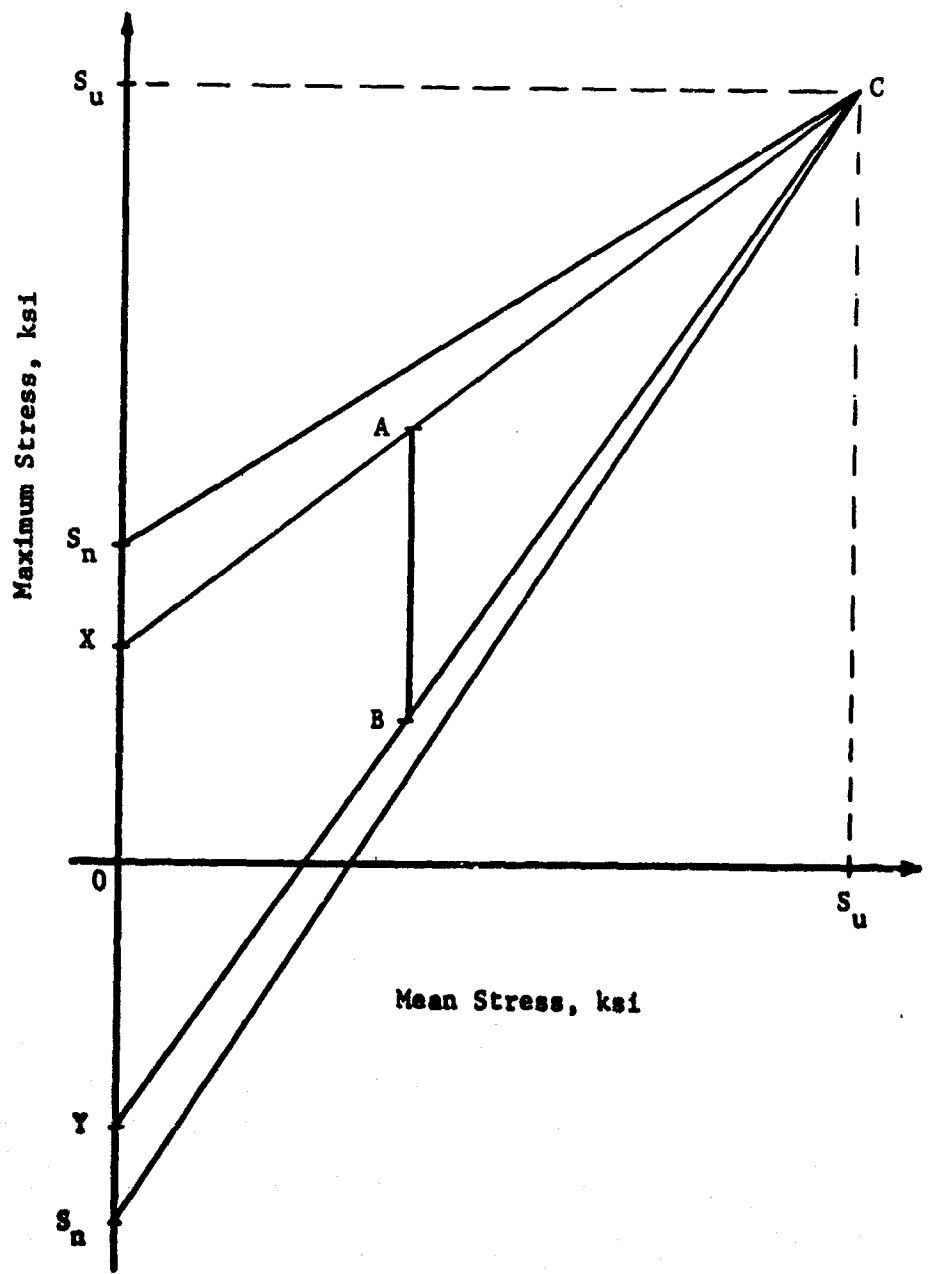

Figure 7.3 A Modified Goodman Diagram

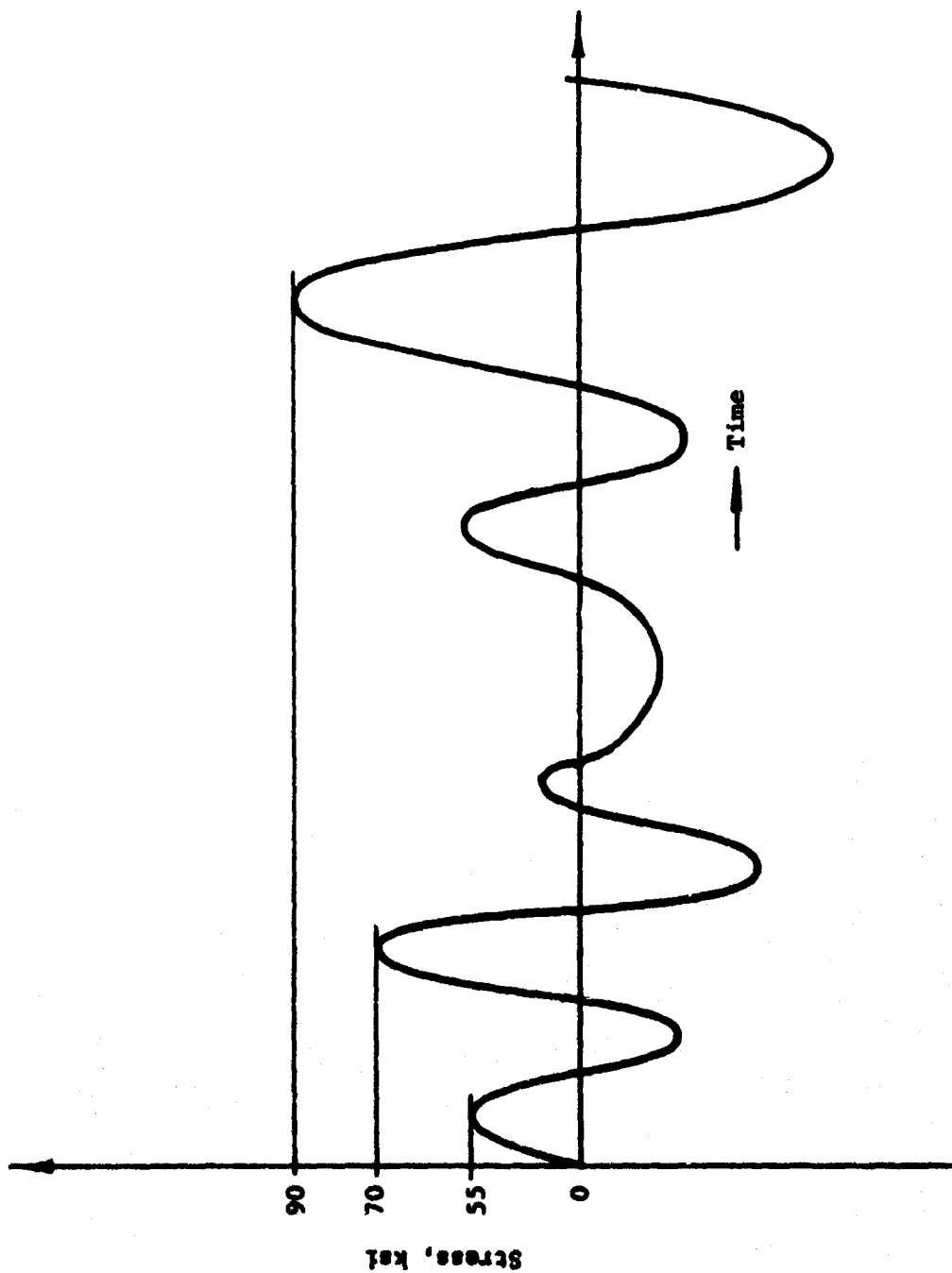

Figure 7.4 The Completely Reversed Stress Reduced from the Stress Spectrum by Means of a Modified Goodman Diagram



Thus, the life of the part under the above spectrum of stresses will be equivalent to a life of  $1.5 \times 10^5$  cycles. The completely reversed stress equivalent to this life is (from Figure 7.5) 75 ksi. Hence, the damage that the part accumulates due to the above spectrum of varying stress amplitude will be the same as if stress cycles of constant amplitude equal to  $S_{equ}$  (in this case 75 ksi) were imposed for  $N_{equ}$  ( $1.5 \times 10^5$  cycles). Thus, the spectrum of stresses can be replaced by a single stress.

Miner's Rule, as stated in Equation (7.1), gives one (1.0) as the criterion for failure. Miner's original tests showed that the value for the summation in Equation 7.1 actually varied between 0.61 and 1.45. His more recent data<sup>(11)</sup> gives a range of 0.7 to 2.2. Other sources<sup>(12)</sup> quote a range as high as 0.18 to 23.0. In view of all this scatter, it is generally agreed that the value of one (1.0), originally proposed by Miner, is probably the best overall estimate that can be made at this time.

### 7.2.2 Corten-Dolan's Rule

The application of this rule in converting the stress spectrum to a single equivalent stress ( $S_{equ}$ ) is identical to that of Miner's rule, except that the S-N curve used to obtain the life values  $N_1, N_2, \dots, N_k$  is modified. This modification is done, as shown in Figure 7.6, by changing the slope of the S-N curve. A line is drawn with an inverse slope,  $d$ , passing through the point  $N_1$  on the S-N curve, having the maximum stress amplitude (in this case,  $S_1$ ) occurring in the stress spectrum. This new line is known as the Corten-Dolan line.

From available data<sup>(13,14)</sup> it appears that for specimens having no stress concentration ( $K_f = 1$ ), the value of  $d/d' = 0.8$  is a reasonable estimate. A recent study by Harris and Lipson<sup>(15)</sup> indicates that when stress concentrations are present the following relationship can be used

$$d/d' = (0.73 + 0.07 K_f) \quad (7.3)$$

This can be graphically expressed as in Figure 7.7. It will be noted that if  $K_f = 3.5$ ,  $d/d' = 1$ , and this becomes equivalent to the criterion obtained from Miner's Rule.

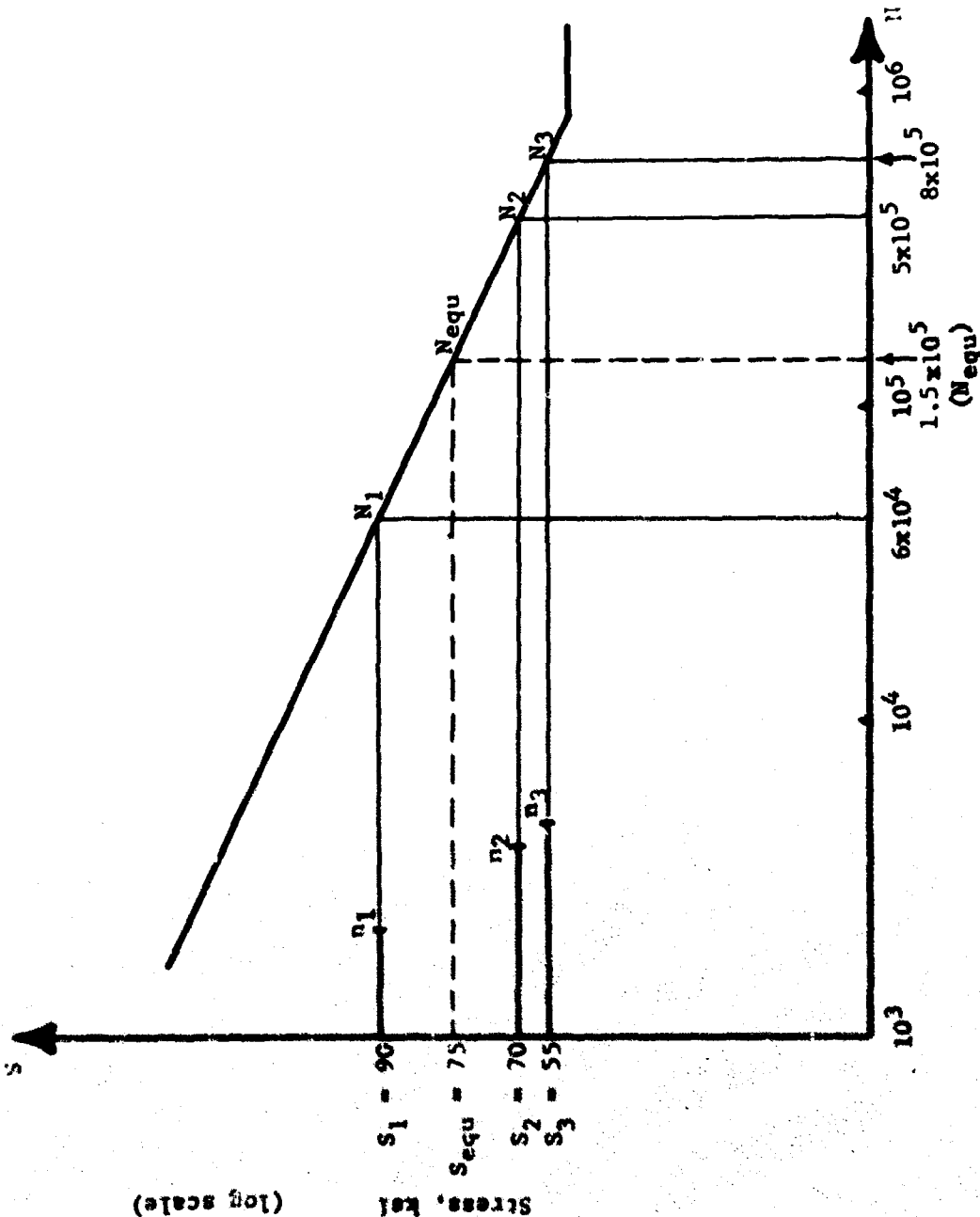

Figure 7.5 Miner's Rule

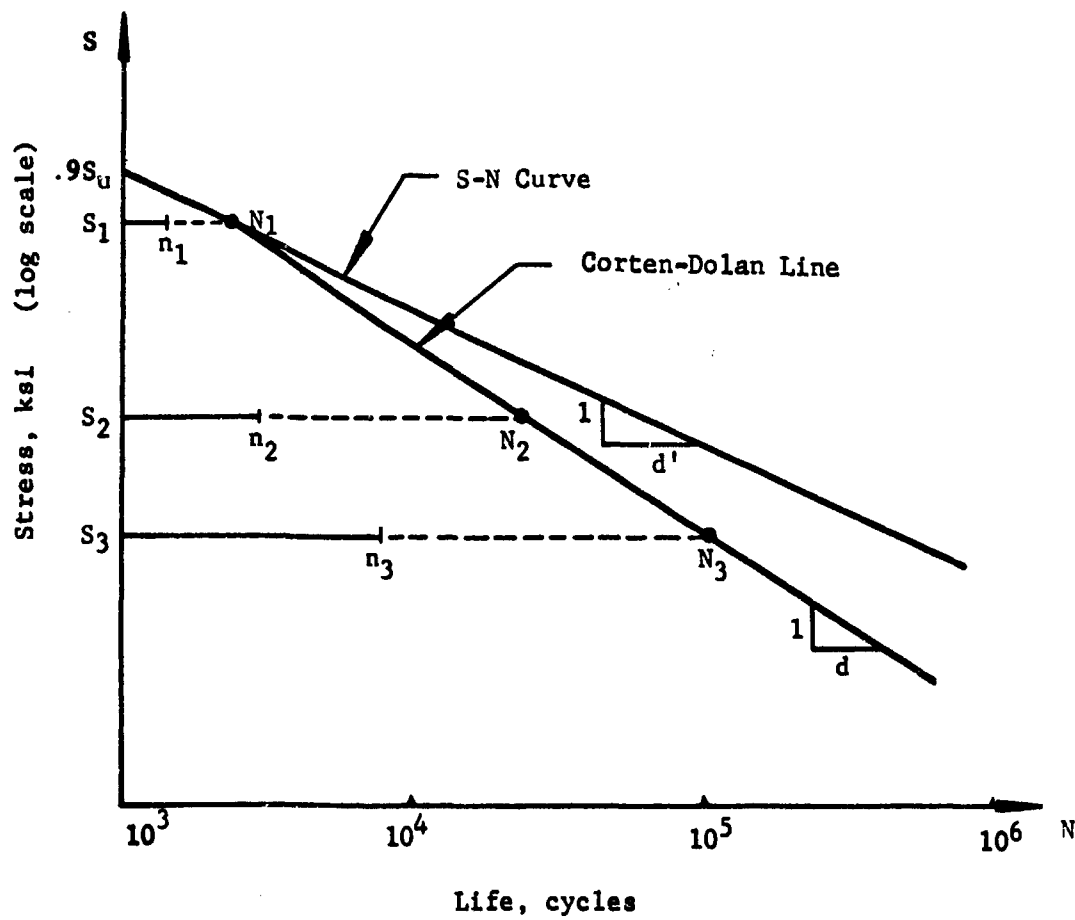

Figure 7.6 The Corten-Dolan Line vs. the S-N Curve

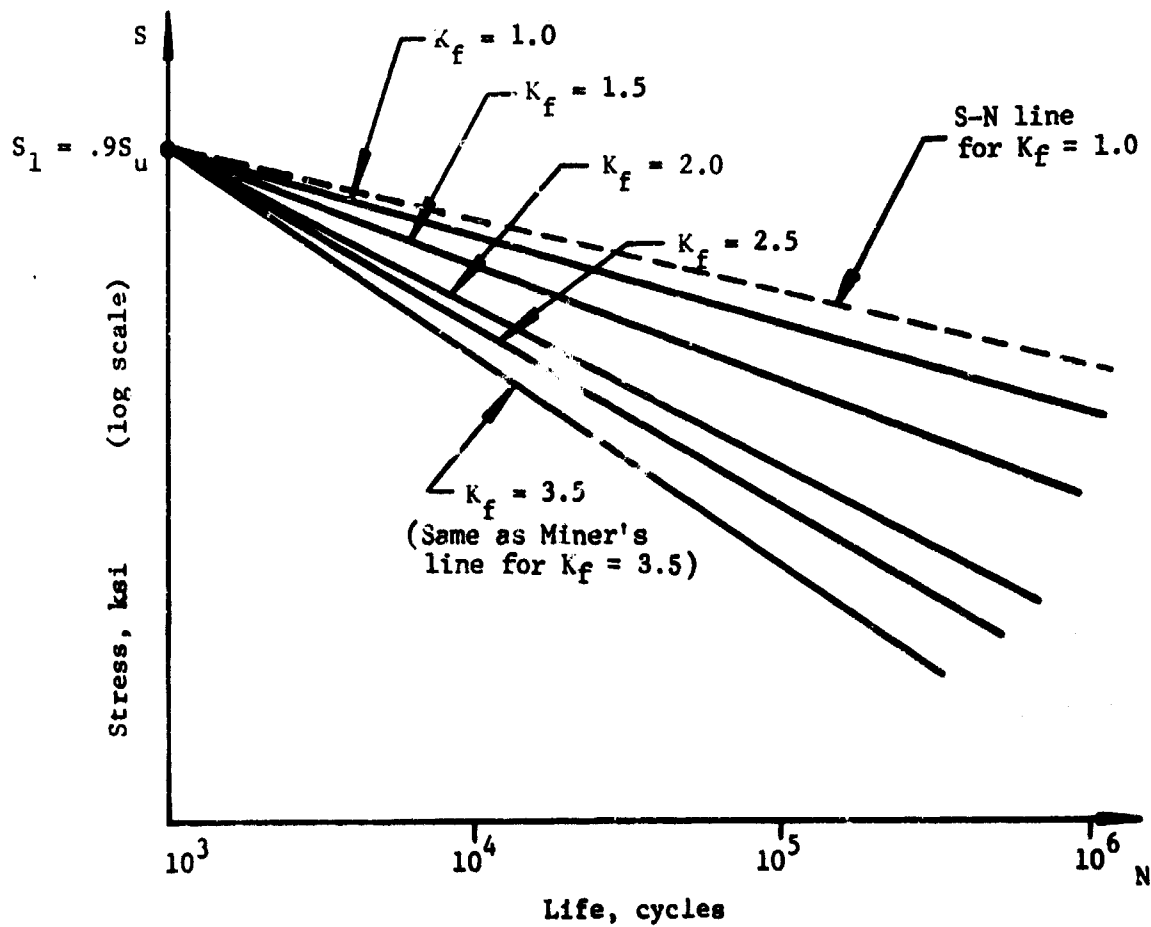

Figure 7.7 Corten-Dolan's Lines for Various Stress Concentration Factors, According to Harris and Lipson<sup>(15)</sup>

## SECTION 8 THE INTERFERENCE OF A STRESS DISTRIBUTION WITH A STRENGTH DISTRIBUTION

After the strength distribution and the stress distribution are determined (Sections 6 and 7 respectively), the two are compared and the percent interference is determined as discussed in Section 2, Section 5, and in detail in Section 9. For a given strength distribution the percent interference will depend on the distribution of the equivalent stress  $S_{equ}$ . A search through literature and other sources produced a considerable amount of data leading to the distribution of strength but very little information on the distribution of stress.

In some engineering applications there is very little scatter in stresses. This leads to a stress distribution with a standard deviation equal to zero. This distribution can be represented by a straight line, as in Figure 8.1, and the interference can be determined as shown.

For a given  $S_{equ}$ , interference may increase or decrease if the life to which the components are designed is changed. This is shown in Figure 8.2, and in terms of S-N diagram in Figure 8.3. The shape of the distribution curve in Figure 8.2 is different from those in Figure 8.3 because the former are plotted on a linear scale and the latter on a log-log scale.

In those engineering applications where the scatter in stresses is appreciable, the above approach will obviously not apply. On the basis of past experience, in the present investigation the stress distribution ( $S_{equ}$ ) was assumed to be normal and the range of standard deviations to be not less than  $.01\mu$  and not more than  $.10\mu$  where  $\mu$  is equal to  $S_{equ}$ . The resulting interference is represented qualitatively in Figure 3.4.

Examples of design problems employing this method are given in Section 9.

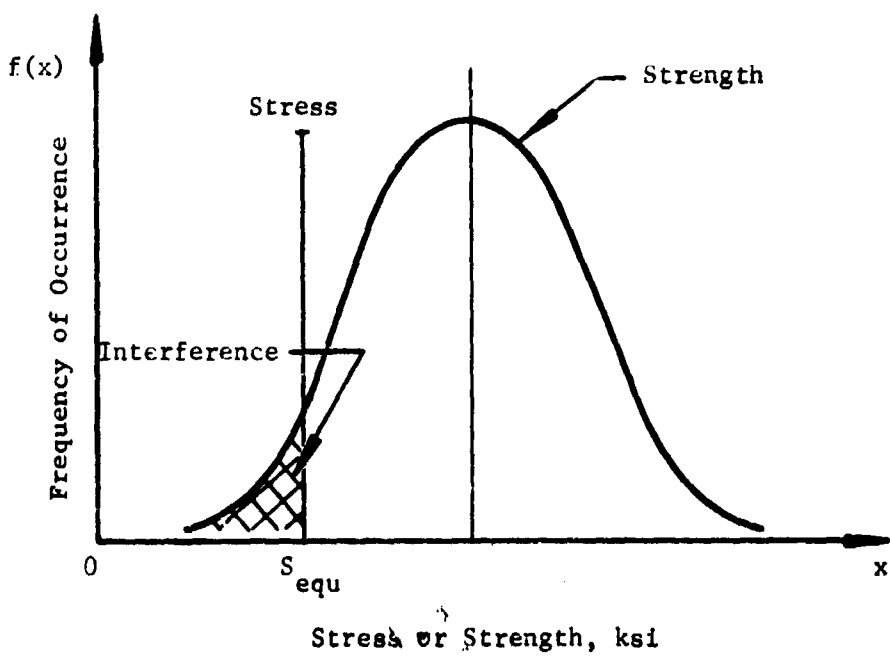

Figure 8.1 Interference with Standard Deviation of Stress equal to Zero

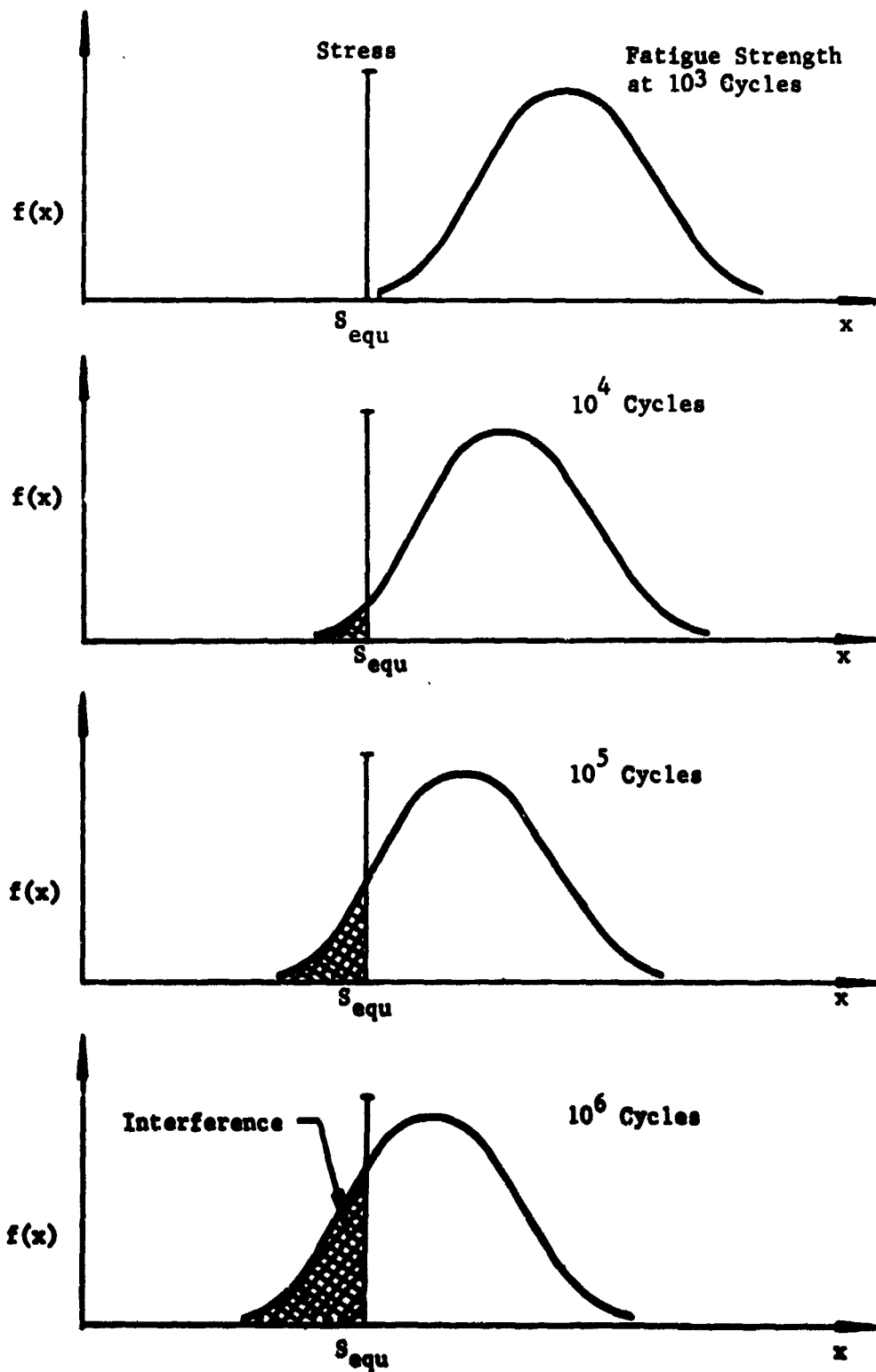

Figure 8.2 Interference of  $S_{equ}$  with Strength Distribution at Different Lives

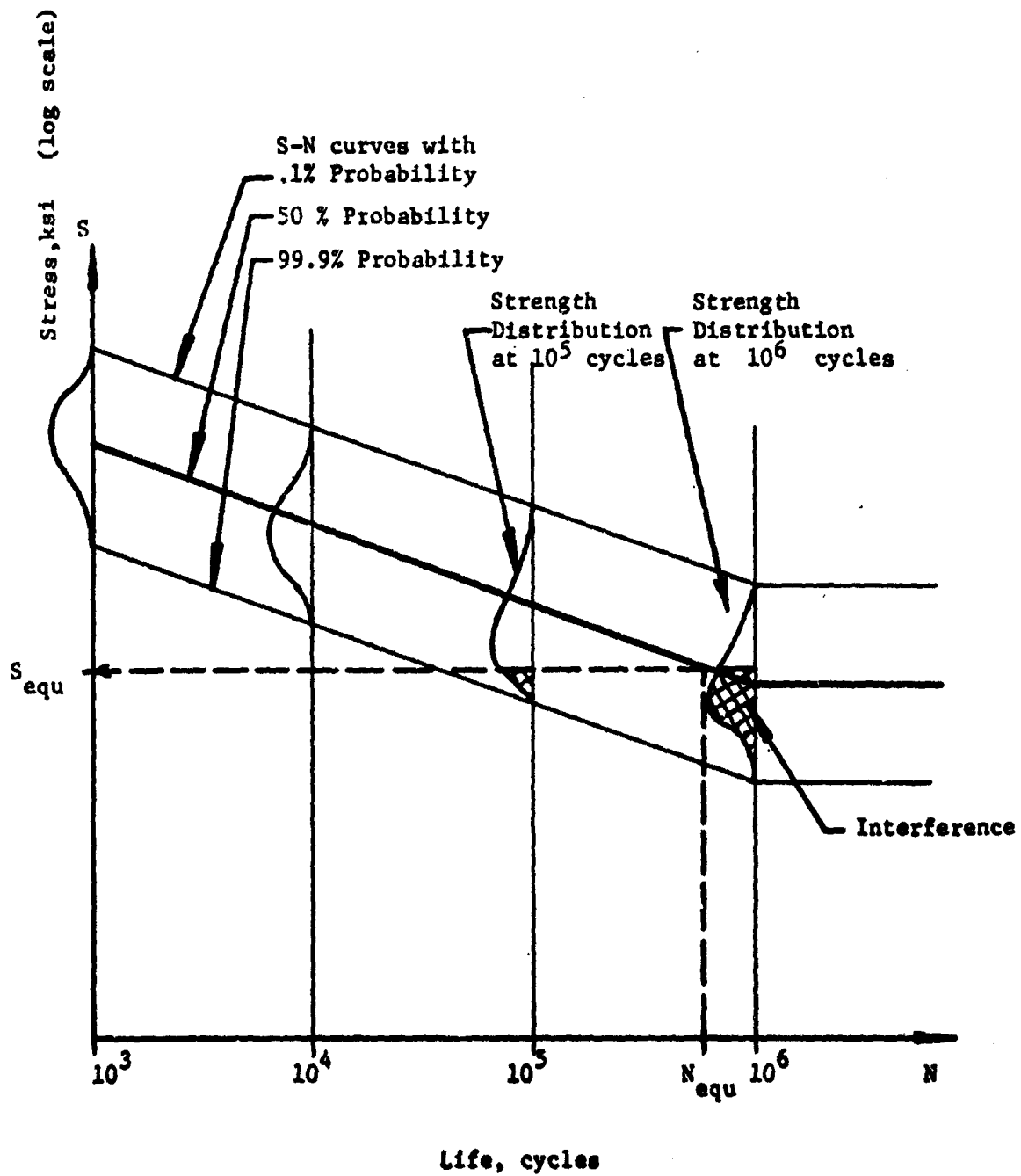

Figure 8.3 S-N Diagram Representing the Dependence of Interference on Life



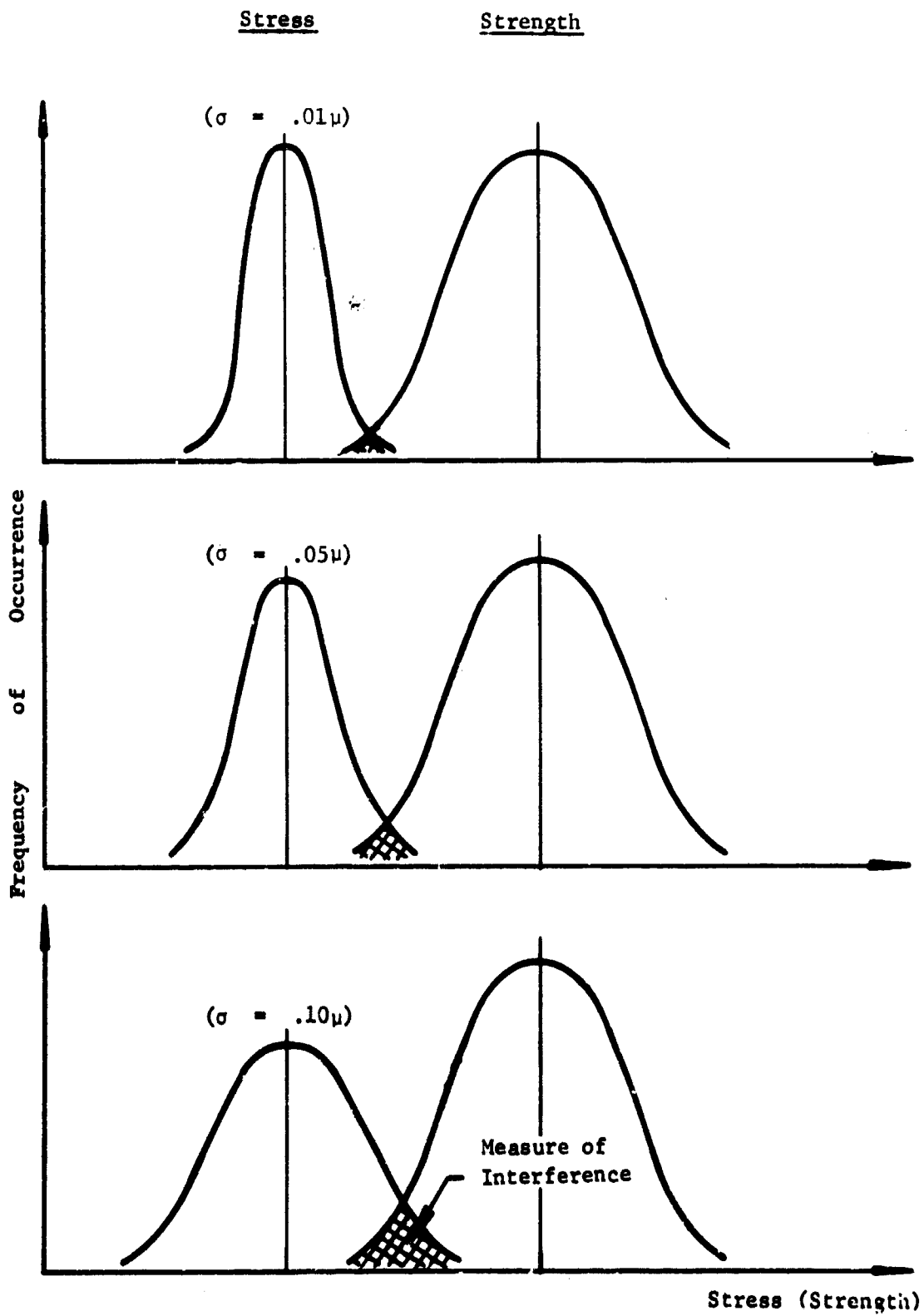

Figure 8.4 Interference of  $S_{equ}$  with Strength Distribution for Various Values of Standard Deviation

## SECTION 9 APPLICATION OF INTERFERENCE THEORY TO DESIGN PROBLEMS

Once the parameters of the strength distribution ( $X_o, \theta, b$ ; or  $\mu, \sigma$ ; or  $\beta, M$ ) and the stress distribution ( $\mu = S_e \mu$  and  $\sigma = K \mu$ , where  $K$  represents a fraction of the average stress) are determined, as shown in Sections 6 and 7 respectively, the percent interference and consequently the reliability (Reliability =  $1 - \text{Interference}$ ) can be computed with the aid of the tables in Appendix 2. The specific steps to be taken in solving particular design problems are illustrated by the following examples.

### 9.1 EXAMPLE PROBLEM NO. 1 (EFFECT OF STRESS CONCENTRATION ON RELIABILITY)

The present design for an aircraft part specifies the following:

Material:	2024 Aluminum $S_u = 70$ ksi, $S_y = 50$ ksi
Design Life:	$10^6$ cycles
Type of Loading:	Axial
Size:	.125" sheet
Surface Finish:	Electropolished
Stress Concentration Factor:	$K_t = 2.4$ (Hole)
Operating Temperature:	Room Temperature

An alternative design calls for reducing the stress concentration at the critical section, at additional cost, by milling an edge notch instead of drilling a hole. This alternative design reduces the theoretical stress concentration factor,  $K_t$ , to 1.5. Will the resultant reduction in stress concentration affect the reliability of the part?

#### 9.1.1 Strength Parameters

The first step is to determine the strength distribution in terms of its parameters corresponding to the design conditions. From the table on Page 194 (Code No. 100), at  $10^6$  cycles the strength distribution of the present design is found to be:

Strength Distribution:	Weibull
Strength Parameters:	$X_o = 13.76$ ksi
	$b = 1.808$
	$\theta = 16.31$ ksi

For the alternative design, the strength distribution at  $10^6$  cycles is found from the table on Page 194 (Code No. 102) to be:

Strength Distribution: Smallest Extreme Value  
 Strength Parameters:  $\beta = .8348$   
 $M = 19.98 \text{ ksi}$

### 9.1.2 Stress Parameters

In order to determine the parameters of the stress distributions ( $\mu = S_{\text{equ}}$  and  $\sigma = K\mu$ ), a prototype of each design was instrumented and the stress spectrums were recorded as shown in Columns 1 and 2 of Tables 9.1 and 9.2. To determine the equivalent stress ( $S_{\text{equ}}$ ), Miner's rule is used. From the S-N curves of the material (Figure 9.1 and 9.2) the number of cycles to failure,  $N$ , corresponding to the stresses in Column 1 of Tables 9.1 and 9.2 are determined. These are shown in Column 3 of Tables 9.1 and 9.2.

Using Miner's Rule, as expressed in Equation (7.2), and the tabulated data in Table 9.1,  $N_{\text{equ}}$  is determined for the present design:

$$N_{\text{equ}} = 1 \times \frac{\sum n_i}{\sum \frac{n_i}{N_i}}$$

$$N_{\text{equ}} = 1 \times \frac{1035}{255.7 \times 10^{-6}} = 4.05 \times 10^6 \text{ cycles}$$

From the S-N curve (Figure 9.1) the stress corresponding to  $N_{\text{equ}} = 4.05 \times 10^6$  cycles is found to be  $S_{\text{equ}} = 13.7 \text{ ksi}$ . Hence, the application of a completely reversed stress of 13.7 ksi can be substituted for the recorded stress spectrum in Columns 1 and 2 of Table 9.1. Similarly, using the data from Table 9.2 for the alternative design:

$$N_{\text{equ}} = 1 \times \frac{1035}{68.80 \times 10^{-6}} = 1.51 \times 10^7 \text{ cycles}$$

From the S-N Curve (Figure 9.2) the stress corresponding to  $N_{\text{equ}} = 1.51 \times 10^7$  cycles is found to be  $S_{\text{equ}} = 13.5 \text{ ksi}$ .

In some engineering applications, the scatter in operating stresses is very small, therefore, the standard deviation of the equivalent stress can be assumed to be zero. In those engineering applications where the scatter in stress is appreciable, the standard deviation lies in the range:

$$0.01\mu \leq \sigma \leq 0.10\mu$$

In the absence of any specific information, an average value of  $\sigma = .05\mu$  can probably be assumed. For the present problem, interference will be calculated for the two cases:  $\sigma = 0$  and  $\sigma = .05\mu$ .

Thus, the stress parameters for the present design are:

Case 1.  $\mu = S_{\text{equ}} = 13.7 \text{ ksi}$  and  $\sigma = 0$  and,

Case 2.  $\mu = 13.7 \text{ ksi}$  and  $\sigma = .05\mu = (.05)(13.7) = .685 \text{ ksi}$ .

## PRESENT DESIGN

Stress Spectrum		Miner's Rule Data	
Completely* Reversed Axial Stresses, ksi	Number of Occurrences, $N_i$	Cycles to Failure, $N_i$	$\frac{n_i}{N_i}$
1	2	3	4
11.7	240	$1.5 \times 10^7$	$16.0 \times 10^{-6}$
12.5	217	$9 \times 10^6$	$24.1 \times 10^{-6}$
13.0	176	$6.2 \times 10^6$	$28.4 \times 10^{-6}$
13.8	150	$3.9 \times 10^6$	$38.4 \times 10^{-6}$
14.1	110	$2.9 \times 10^6$	$37.9 \times 10^{-6}$
14.9	75	$1.8 \times 10^6$	$41.6 \times 10^{-6}$
15.7	52	$1.15 \times 10^6$	$45.2 \times 10^{-6}$
15.9	20	$1.05 \times 10^6$	$19.0 \times 10^{-6}$
16.0	5	$1.0 \times 10^6$	$5.0 \times 10^{-6}$
$\sum n_i = 1035$		$\sum \frac{n_i}{N_i} = 255.7 \times 10^{-6}$	

Table 9.1 Stress and Life Data for Miner's Rule

\*Actually, the stress was not completely reversed. It was reduced with the aid of Goodman Diagram to a completely reversed stress using the procedure given in Section 7.2.

## ALTERNATIVE DESIGN

Stress Spectrum		Miner's Rule Data	
Completely* Reversed Axial Stresses, ksi	Number of Occurrences, $n_i$	Cycles to Failure, $N_i$	$\frac{n_i}{N_i}$
1	2	3	4
11.7	240	$5.1 \times 10^7$	$4.70 \times 10^{-6}$
12.5	217	$3.0 \times 10^7$	$7.24 \times 10^{-6}$
13.0	176	$2.1 \times 10^7$	$8.39 \times 10^{-6}$
13.8	150	$1.3 \times 10^7$	$11.52 \times 10^{-6}$
14.1	110	$1.1 \times 10^7$	$10.00 \times 10^{-6}$
14.9	75	$7.2 \times 10^6$	$10.40 \times 10^{-6}$
15.7	52	$4.8 \times 10^6$	$10.81 \times 10^{-6}$
15.9	20	$4.4 \times 10^6$	$4.55 \times 10^{-6}$
16.0	5	$4.2 \times 10^6$	$1.19 \times 10^{-6}$
$\sum n_i = 1035$		$\sum \frac{n_i}{N_i} = 68.80 \times 10^{-6}$	

Table 9.2 Stress and Life Data for Miner's Rule

\*Actually, the stress was not completely reversed. It was reduced with the aid of a Goodman diagram to a completely reversed stress using the procedure given in Section 7.2.

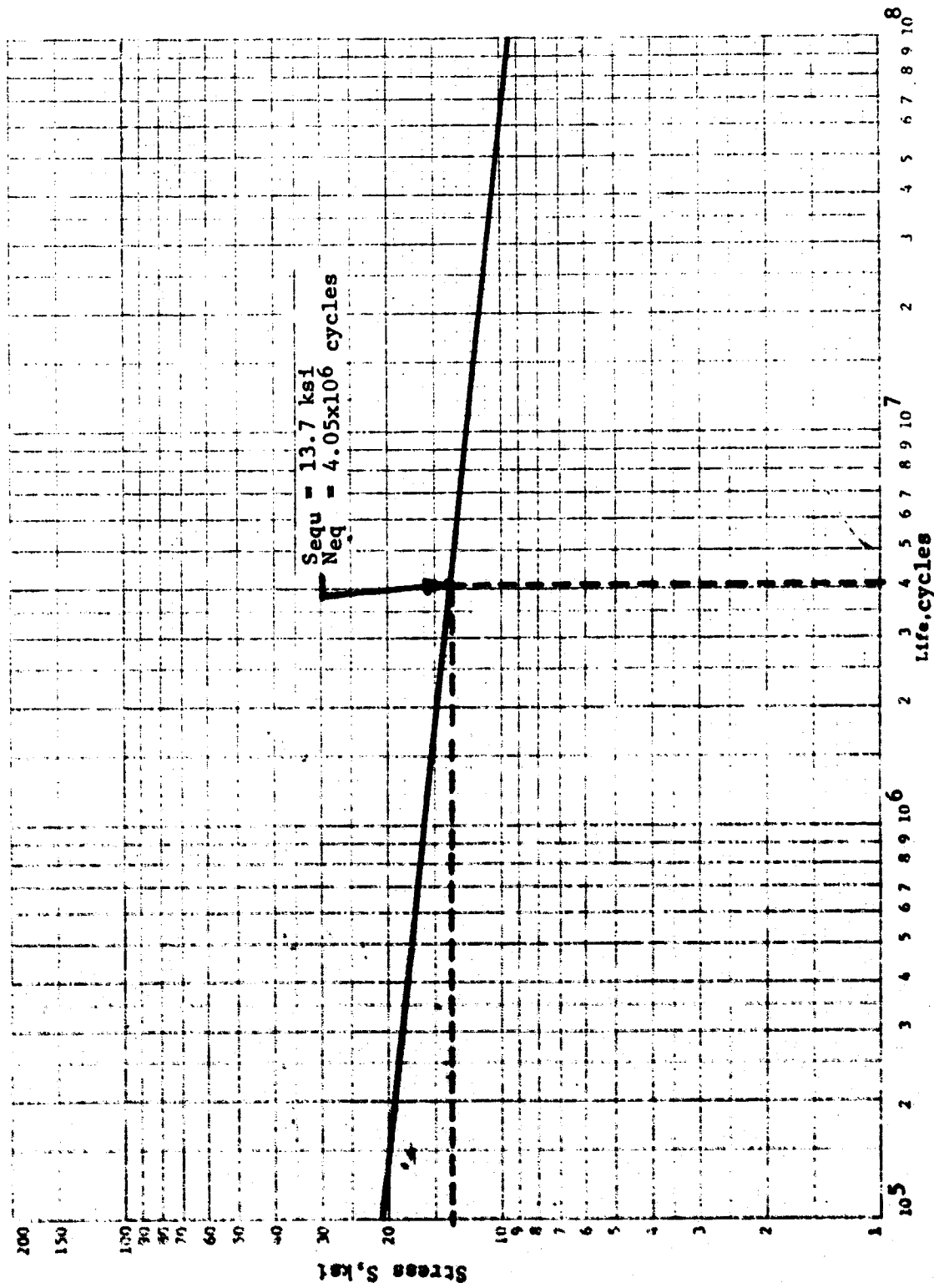

Figure 9.1 S-N Relationship for the Present Design

NOT REPRODUCIBLE

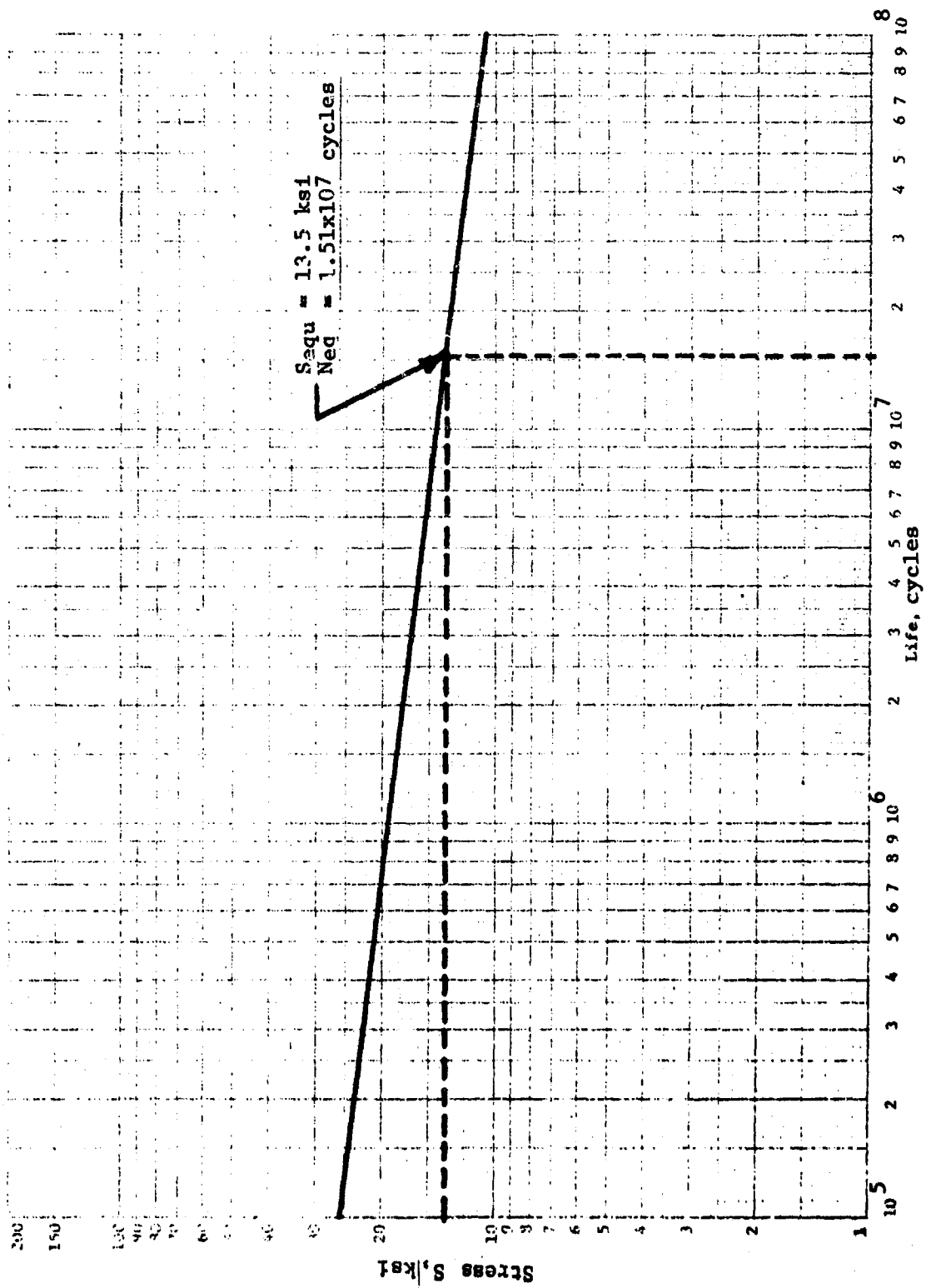

Figure 9.2 S-N Relationship for the Alternative Design

Similarly, the stress parameters for the alternative design are:

1.  $\mu = S_{equ} = 13.5$  ksi and  $\sigma = 0$
- and 2.  $\mu = 13.5$  ksi and  $\sigma = .05\mu = (.05)(13.5) = .675$  ksi.

### 9.1.3 Percent Interference

Once the strength and stress distribution parameters are determined, the Percent Interference and the Reliability (%Reliability = 100-% Interference) can be determined.

Case (1) when stress standard deviation ( $\sigma$ ) = 0:

For this case where stress is Normally distributed with  $\mu = S_{equ}$  and  $\sigma = 0$ , the percent interference can be determined as follows:

#### Present Design

For Weibull distributed strength,

$$\text{Interference } F(x) = 1 - e^{-\left(\frac{x-X_0}{\theta-X_0}\right)^b} = \text{shaded area under Figure 8.1}$$

where  $x = S_{equ} = 13.70$  ksi

$X_0 = 13.76$  ksi

$b = 1.808$

$\theta = 16.31$  ksi

$$F(x) = 1 - e^{-\left(\frac{13.70-13.76}{16.31-13.76}\right)^{1.808}}$$

$$= 0$$

Percent Interference = 0%

It can also be seen, from Figure A-2.1 in Section A-2.2.1, that when  $S_{equ}$  is less than  $X_0$  there is no Interference. In the case when  $S_{equ}$  is greater than  $X_0$ , the Percent Interference can be determined as:

Find,

$$x = \left(\frac{S_{equ} - X_0}{\theta - X_0}\right)^b$$

Corresponding to the value of  $x$  read interference  $F(x)$  from the table in Section A-2.2.1, Pages 371 or 372.

#### Alternative Design

For Smallest Extreme Value distributed strength,

$$\text{Interference } F(x) = 1 - e^{-\theta(x-M)} = \text{shaded area under Figure 8.1}$$



where  $x = S_{equ} = 13.50$  ksi

$$\beta = .8348$$

$$M = 19.98$$

$$\begin{aligned} F(x) &= 1 - e^{-e^{.8348(13.50-19.98)}} \\ &= 1 - e^{-e^{-5.404}} = 1 - e^{-.0045} \\ &= .0045 \end{aligned}$$

Percent Interference = .45%

This can also be read directly from the table in Section A-2.5.1, Page 419.

$$\begin{aligned} \text{Find } X &= -\beta(S_{equ} - M) = -.8348 (13.50 - 19.98) \\ &= 5.404 \end{aligned}$$

Corresponding to  $X = 5.404$  read interference  $F(x) = .0045$  from the above table. Therefore, Percent Interference = .45%.

Case (2) when stress standard deviation ( $\sigma$ )  $\neq 0$ : (in this case  $\sigma = .05\mu$ )

For this case where stress is Normally distributed with  $\sigma \neq 0$ , additional interference parameters must be calculated to determine the percent interference.

#### Present Design

##### Strength (Weibull)

$$X_0 = 13.76 \text{ ksi}$$

$$b = 1.808$$

$$\theta = 16.31 \text{ ksi}$$

##### Stress (Normal)

$$\mu = S_{equ} = 13.70 \text{ ksi}$$

$$\sigma = 0.05\mu$$

$$= 0.685 \text{ ksi}$$

For the above data, interference parameters  $C$ ,  $A$ , and  $B(x)$  to be used in the interference tables were computed.

$$C = \frac{\theta - X_0}{\sigma} = \frac{16.31 - 13.76}{0.685} = 3.72$$

$$A = \frac{X_0 - \mu}{\sigma} = \frac{13.76 - 13.70}{0.685} = .0875$$

$$B(x) = b = 1.808$$

From the tables in Section A-2.2.2 on Pages 388 and 390, the interference value corresponding to these parameters is read using linear interpolation (for a higher order and more accurate interpolating technique, see Section A-2.1).

Interference = .0398  
or Percent Interference = 3.98%

Alternative Design

Strength (S.E.V.)

$$\beta = .8348$$

$$M = 19.98 \text{ ksi}$$

Stress (Normal)

$$\mu = S_{equ} = 13.50 \text{ ksi}$$

$$\sigma = .05\mu = .675 \text{ ksi}$$

For the above data, interference parameters  $\alpha$  and  $\gamma$  to be used in the interference tables are computed.

$$\alpha = \beta\sigma = (.8348)(.675) = .564$$

$$\gamma = \beta(S_{equ}-M) = (.8348)(-6.48) = -5.4$$

From the table in Section A-2.5.2 on Page 422, the interference value corresponding to these parameters is read using linear interpolation (for a higher order and more accurate interpolating technique, see Section A-2.1).

Interference = .0059  
or Percent Interference = .59%

A summary of the results is given in Table 9.3.

Thus, the reduction in the stress concentration factor should, in effect, result not only in lower stress but also in somewhat higher reliability.

	Material	Theoretical Stress Concentration Factor, $K_t$	Strength Distribution and its Parameters	Equivalent Stress $S_{eq}$ , ksi	Z Interference at $10^6$ cycles		Z Reliability at $10^6$ cycles (100-Zinterfer.)	
					$\sigma=0$	$\sigma=.05\mu$	$\sigma=0$	$\sigma=.05\mu$
Present Design	2024 Aluminum	2.4	<u>Weibull</u> $X_0 = 13.76$ ksi $b = 1.808$ $\theta = 16.31$ ksi	13.7	0	3.98	100.00	96.02
Alternative Design	2024 Aluminum	1.5	<u>S.E.V.</u> $\beta = .8348$ $M = 19.98$ ksi	13.5	.45	.59	99.55	99.41

Table 9.3 Effect of Stress Concentration Factor on Reliability at  $10^6$  Cycles

## 9.2 EXAMPLE PROBLEM NO. 2 (EFFECT OF TEMPERATURE ON RELIABILITY)

A part in service has been performing satisfactorily under the following conditions:

Material:	Ti-4Al-3Mo-1V; .125" sheet; $S_u = 16.0$ ksi
Loading:	Axial $S_y = 13.2$ ksi
Surface Finish:	Ground
Stress Concentration Factor at Critical Section:	$K_t = 1.0$
Operating Temperature:	400°F
Reliability Requirement:	99.99% at $5 \times 10^6$ cycles
Stress Parameters for the Critical Section:	$\mu = 28.2$ ksi (Previously determined) $\sigma = 1.41$ ksi

If the efficiency of the system can be increased by increasing the operating temperature, how will the reliability of the component part be affected if the temperature is increased to 600°F, 800°F, and the stress parameters remain the same?

### 9.2.1 Strength Parameters

From the table on Page 303 (Code Nos. 586 and 587) the strength parameters for 600°F and 800°F at  $5 \times 10^6$  cycles are:

#### 600°F

Strength Distribution: Largest Extreme Value  
Strength Parameters:  $\beta = .2066$   
 $M = 40.79$  ksi

#### 800°F

Strength Distribution: Largest Extreme Value  
Strength Parameters:  $\beta = .2836$   
 $M = 28.74$  ksi

### 9.2.2 Stress Parameters

The stress parameters have been previously determined and are:

Stress Distribution: Normal

Stress Parameters:  $\mu = S_{equ} = 28.2 \text{ ksi}$

$\sigma = 1.41 \text{ ksi}$

### 9.2.3 Percent Interference

With the strength and stress distribution parameters established, the percent interference can be determined at the various temperatures:

#### 600°F

Strength Distribution: Largest Extreme Value ( $\beta, M$ )

Stress Distribution: Normal ( $\mu, \sigma$ )

Interference Parameters:

$$\alpha = \beta\sigma = .2066 (1.41) = .292$$

$$\gamma = \beta(\mu - M) = .2066 (28.2 - 40.79) = -2.6$$

Using parameters ( $\alpha, \gamma$ ), the interference at  $5 \times 10^6$  cycles is obtained by linear interpolation from the table in Section A-2.4.2 on Page 411 (For a more accurate interpolation method, see Section A-2.1).

$$\text{Interference} = .00092$$

$$\text{Percent Interference} = .092\%$$

$$\text{Percent Reliability} = (100 - \% \text{ Interference})$$

$$= 99.908\%$$

#### 800°F

Strength Distribution: Largest Extreme Value ( $\beta, M$ )

Stress Distribution: Normal ( $\mu, \sigma$ )

Interference Parameters:

$$\alpha = \beta\sigma = (.2836)(1.41) = .400$$

$$\gamma = \beta(\mu - M) = .2836 (28.20 - 28.74) = -.153$$

Using parameters ( $\alpha, \gamma$ ), the interference at  $5 \times 10^6$  cycles is obtained by linear interpolation from the table in Section A-2.4.2 on Page 411 (For a more accurate interpolation method, see Section A-2.1).

$$\begin{aligned}\text{Interference} &= .33426 \\ \text{Percent Interference} &= 33.426\% \\ \text{Percent Reliability} &= (100 - \% \text{ Interference}) \\ &= 66.574\%\end{aligned}$$

A summary of the results is given in Table 9.4.

Thus, an increase in the operating temperature from  $600^\circ\text{F}$  to  $800^\circ\text{F}$  results in an appreciable reduction in reliability.

Material	Temperature °F	Strength Distribution and its Parameters	Stress Distribution and its Parameters	Percent Interference at 5 x 10 <sup>6</sup> cycles	Percent Reliability at 5 x 10 <sup>6</sup> cycles (100-%Interference)
T1-4 Al-3 Mo-1 V Sheet	400	Present Operating Temperature	<u>Normal</u> $\mu = \text{Sequ}$ $= 28.2 \text{ ksi}$ $\sigma = 1.41 \text{ ksi}$	.010	99.990
	600	<u>L.E.V.</u> $\beta = .2066$ $M = 40.79 \text{ ksi}$		.092	99.908
	800	<u>L.E.V.</u> $\beta = .2836$ $M = 28.74 \text{ ksi}$		33.426	66.574

Table 9.4 Effect of Temperature on Reliability at 5 x 10<sup>6</sup> cycles.

### CONCLUSIONS AND RECOMMENDATIONS

1. A method was developed for employing Stress-Strength Interference Theory as a practical engineering tool to be used for designing and quantitatively predicting the reliability of mechanical parts and components, made of non-ferrous materials, subjected to mechanical loading.
2. This method is based on considerable empirical data gathered (Appendix 1) and it also has sound theoretical basis (Appendix 3). This method eliminates the concept of a Factor of Safety and substitutes Percent Interference (Probability of Failure). Tables of interference values are given in Appendix 2 for a variety of stress and strength conditions.
3. Although a great deal of data was gathered and analyzed in the course of the present study, no data were found to permit the establishment of confidence intervals on the probability of interference.
4. In our past investigation<sup>(1)</sup>, because of the limitations of the graphical approach employed, this method was limited to the following three cases:

Stress Distribution

Normal  
Normal  
Weibull

Strength Distribution

Normal  
Weibull  
Weibull

In the present investigation, based on the computer approach, the method was extended to the following three additional cases:

Stress Distribution

Normal  
  
Normal  
Normal

Strength Distribution

Weibull (Extended-see Section 4.2)  
Largest Extreme Value  
Smallest Extreme Value

5. For these combinations of stress and strength distributions, interference values were calculated by an Integral Method and these are tabulated in Appendix 2. These values were found to be highly non-linear. Therefore, for the purpose of interpolating these values in a given table or between the tables, a higher order interpolation (Section A-2.1) should be used.
6. A computer approach (referred to above) was developed for determining the statistical distribution function of fatigue strength at a given life. When the raw data (conventional S-N type data) were fed into this computer program, the computer printed the correlation coefficient (a degree of fit) and the parameters for Normal, Weibull, Largest Extreme Value and Smallest Extreme Value distributions, for any given set of strength data. This method has the advantage of high accuracy and time saving over the graphical method used in the previous investigation.<sup>(1)</sup>
7. The effect of type of loading, surface finish, stress concentration, heat treatment, Temperature, environment and other factors (Section 4.4) on the statistical distribution function of fatigue strength of various non-fer-



rous materials was studied. These effects were expressed in terms of the distribution parameters which were tabulated (Appendix 1, pages 155-350) and the representative ones plotted (Section 6.7, pages 53-117).

8. In most cases, the effect of the factors listed under item 7 above was to change the distribution function. That is, for a given material and surface finish the distribution function might be Weibull but for the same material and different surface finish, the distribution could change to Largest Extreme Value. (This refers to the best fitting distribution for each particular material and set of conditions, as described in Section 6.6). The only exception is the effect of life. Life was found to retain the same distribution and change only the parameters of that distribution (see the basic assumption given in Section 6.2 on page 31).
9. For the non-ferrous materials studied, the effect of life on the fatigue strength distribution parameters is shown in the table below:

Fatigue Strength Distribution	Distribution Parameters	Effect of Life on Distribution Parameters
Weibull	$X_0$	Linearly decreases with life on log-log scale
	$\theta$	Linearly decreases with life on log-log scale
	$b$	Increases or decreases with life depending on conditions
Normal	$\mu$	Linearly decreases with life on log-log scale
	$\sigma$	Decreases with life
Largest Extreme Value	$M$	Linearly decreases with life on log-log scale
	$\beta$	Increases with life
Smallest Extreme Value	$M$	Linearly decreases with life on log-log scale
	$\beta$	Increases with life

10. As to the problem of stress, the stress distribution was investigated in more detail than in the previous study<sup>(1)</sup> but no additional information was located.
11. In order to verify the validity of the Interference Technique developed in the present study, it should be checked against an actual life situation. That is, percent interference should be computed for an actual engineering problem. These results then should be compared with actual service failures.

## REFERENCES

1. Lipson, C., Sheth, N.J., Disney, R.L., "Reliability Prediction - Mechanical Stress/Strength Interference. Rome Air Development Center, Griffiss Air Force Base: Final Report No. RADC-TR-66-710, March 1967.
2. Lipson, C., Sheth, N.J., Pittman, R.B., "Designing Engineering Experiments," Engineering Summer Conference, Department of Mechanical Engineering, University of Michigan, Ann Arbor, Michigan, May 1968.
3. Lipson, C., Kerawalla, J., and Mitchell, L., Engineering Applications of Reliability. Engineering Summer Conference, Department of Mechanical Engineering, University of Michigan, Ann Arbor, Michigan, 1963.
4. Grover, H.J., Gordon, S.A., and Jackson, L.R., "Fatigue of Metals and Structures," Department of Navy, U.S. Government Printing Office, 1960.
5. Heywood, R.B., Designing Against Fatigue. London: Chapman and Hall, Ltd., 1962.
6. Lipson, C. and Juvinall, R.C., Handbook of Stress and Strength, New York: The Macmillan Co., 1963.
7. Johnson, Leonard G., "GMR Reliability Manual." GMR-302, 1960. Research Laboratories, General Motors Corporation.
8. Gumbel, Emil J., "Statistical Theory of Extreme Values and Some Practical Applications," National Bureau of Standards, Applied Mathematics Series 33, 1954.
9. National Bureau of Standards, "A Guide to Tables of the Normal Probability Integral." Applied Mathematics Series, #21, Washington: U.S. Government Printing Office, 1952.
10. Miner, M.A., "Cumulative Damage in Fatigue." Journal of Applied Mechanics, Volume 12, 1945.
11. Miner, M.A., "Estimation of Fatigue Life with Particular Emphasis on Cumulative Damage." Chapter 12 of Metal Fatigue, edited by Sines, George, and J.L. Waisman, New York: McGraw-Hill Book Co., 1959.
12. Dolan, T.J.; Richart, F.E.; and Work, C.E., "Influence of Fluctuation in Stress Amplitude on the Fatigue of Metals." ASTM Proceedings, Vol. 49, 1949.
13. Richart, F.E.; and Newmark, N.M., "An Hypothesis for the Determination of Cumulative Damage in Fatigue." ASTM Proceedings. Vol. 48. 1948.
14. Grover, H.J.; Bishop, S.M.; and Jackson, L.R., "Fatigue Strength of Aircraft Materials: Axial Load Fatigue Tests on Unnotched Sheet Specimens of 24S-T3 and 75S-T6 Aluminum Alloys and of SAE 4130 Steel." NACA Tech. Note 2324, 1951.

15. Harris, J.P., and Lipson, C., "Cumulative Damage Due to Spectral Loading" Aerospace Reliability and Maintainability Conference, SAE, ASME, AIAA Conference Proceedings, July, 1964.
16. Henrici, P., "Elements of Numerical Analysis." John Wiley and Sons: March 1967.

## BIBLIOGRAPHY

1. American Society of Testing and Materials, A Guide for Fatigue Testing and the Statistical Analysis of Fatigue Data. Special Technical Publication No. 91-A (Second Edition), 1963.
2. Bazovsky, I., Reliability Theory and Practice. Prentice Hall Inc., Space Technology Series, Chapter 15: "Component Failure Rates at System Stress Levels."
3. Bird, G.T., "On the Basic Concepts of Reliability Prediction." (Monte Carlo) p. 54, Seventh National Symposium on Reliability and Quality Control, 1961.
4. Bowker, A.H. and Lieberman, G.J., Engineering Statistics. Prentice-Hall Inc., New Jersey: 1959.
5. Corten, H.T., "Application of Cumulative Fatigue Damage Theory to Farm and Construction Equipment." SAE Paper 735 A, September, 1963.
6. Corten, H.T., "Overstressing and Understressing in Fatigue, (Cumulative Fatigue Damage)." ASME Handbook, Metals Engineering-Design, Second Edition, 1965.
7. Corten, H.T. and Dolan, T.J., "Cumulative Fatigue Damage," The International Conference on Fatigue of Metals, I.M.E. and ASME, September 10-14, 1956.
8. Croxten, F.E. and Cowden, D.J., Practical Business Statistics, Prentice-Hall, New York, 1965.
9. Dieter, G.E. and Mehl, R.F., "Investigation of Statistical Nature of Fatigue of Metals." NACA Technical Note No. 3019, September 1953.
10. Dolan, T.J. and Corten, H.T., "Progressive Damage Due to Repeated Loading." WADC Symposium, Fatigue in Aircraft Structures, August, 1959.
11. Dolan, T.J.; Richart, R.E.; and Work, C.E., "Influence of Fluctuations in Stress Amplitude on the Fatigue of Metals." ASTM Proceedings, Vol. 49, 1949.
12. Forrest, P.G., Fatigue of Metals. New York: Pergamon Press, 1962.
13. Freudenthal, A.M., Fatigue Sensitivity and Reliability of Mechanical Systems. SAE Paper 459 A, January, 1962.
14. Freudenthal, A.M. and Gumbel, E.J., "Distribution Functions for the Prediction of Fatigue Life and Fatigue Strength," The International Conference on Fatigue of Metals. IME and ASME, 1956.
15. Freudenthal, A.M. and Heller, R.A., "On Stress Interaction in Fatigue and a Cumulative Damage Role, Part 1: 2024 Aluminum and SAE 4340 Steel Alloys." WADC Technical Report 58-69, June, 1958.

16. Freund, John E., Mathematical Statistics, New York: Prentice Hall, 1965.
17. Grey, E.F., "Statistical Methods as Design Tools." Eighth National Symposium on Reliability and Quality Control. pp. 70-71, 1962.
18. Grover, H.J.; Gordon, S.A.; and Jackson, L.R., Fatigue of Metals and Structures. Superintendent of Documents, U.S. Government Printing Office, Washington, D.C.: June, 1966.
19. Gumbel, Emil J., "Statistical Theory of Extreme Values and Some Practical Applications," National Bureau of Standards, Applied Mathematics Series 33, 1954.
20. Harris, J.P. and Lipson, C., "Cumulative Damage Due to Spectral Loading." Aerospace Reliability and Maintainability Conference. SAE, ASME, AIAA Conference Proceedings, July, 1964.
21. Haugen, E.B., "Statistical Methods for Structural Reliability Analysis." Appendix p. 110-121, Tenth Symposium on Reliability and Quality Control. pp. 97-109, 1964.
22. Haviland, R.P., "Introduction to Theory of Reliability." SAE Paper 343 D, 1961.
23. Henrici, P., "Elements of Numerical Analysis." John Wiley and Sons: March 1967.
24. Heywood, R.B., Designing Against Fatigue. London: Chapman and Hall, 1962
25. Johnson, Leonard G., "GMR Reliability Manual." GMR-302, 1960. Research Laboratories, General Motors Corporation.
26. Kaechele, L.E., "Designing to Prevent Fatigue Failures." Rand Report P-3022. February, 1965.
27. Kaechele, L.E., "Probability and Scatter in Cumulative Fatigue Damage." Rand Report, RM-3688-PR. December, 1963.
28. Kaechele, L.E., "Review and Analysis of Cumulative Damage Theories." Rand Report, RM-3650-PR. September, 1963.
29. Kececioglu, D. and Cormier, D., "Designing a Specified Reliability Directly into a Component." Aerospace Reliability and Maintainability Conference, Washington, D.C.: pp. 546-564, 1964.
30. Kullback, S., "The Distribution Laws of the Differences and Quotient of Variables Distributed in Pearson Type III Laws." The Annals of Mathematical Statistics. Volume VII, Number 1, March 1936, pp. 51-53.
31. Langer, B.F., "Fatigue Failure from Stress Cycles of Varying Amplitude." Transactions, ASME. Volume 59, p. A-160, 1937.

32. Lipson, C. and Juvinall, R.C., Handbook of Stress and Strength. New York: The Macmillan Company, 1963.
33. Lipson, C.; Kerawalla, J.; and Mitchell, L., Engineering Applications of Reliability. Engineering Summer Conference, Department of Mechanical Engineering, University of Michigan, Ann Arbor, Michigan, 1963.
34. Lipson, C. and Noll, G.C., "Design Practice." ASME Handbook, Metals Engineering Design, Second Edition, 1965.
35. Lipson, C.; Sheth, N.J.; Disney, R.L., "Reliability Prediction-Mechanical Stress/Strength Interference. Rome Air Development Center, Griffis Air Force Base: Final Report No. RADC-TR-66-710, March 1967.
36. Lipson, C.; Sheth, N.J.; Pittman, R.B., "Designing Engineering Experiments," Engineering Summer Conference, Department of Mechanical Engineering, University of Michigan, Ann Arbor, Michigan, May 1968.
37. Lipson, C.; Sheth, N.J.; and Sheldon, D.B., "Reliability and Maintainability in Industry and the Universities." Fifth Reliability and Maintainability Conference. Volume 5, 1966.
38. Little, R.E., "Design of Fatigue Experiments in Research and Development." University of Michigan #6637-118, Engineering Summer Conferences, Ann Arbor, Michigan, 1966.
39. Little, R.E., Multiple Specimen Testing and the Associated Fatigue Strength Response. The University of Michigan, Ann Arbor, Michigan: January, 1966.
40. Liu, H.W. and Corten, H.T., "Fatigue under Varying Stress Amplitude." NASA Technical Note D-647. November, 1960.
41. Lloyd, David K. and Lipow, Myron, Reliability: Management, Methods and Mathematics. Englewood Cliffs, N.J.: Prentice-Hall, 1962.
42. Miner, M.A., "Cumulative Damage in Fatigue." Journal of Applied Mechanics. Volume 12, No. 3, p. A-159, September, 1945.
43. Mittenbergs, A.A., "Fundamental Aspects of Mechanical Reliability." Mechanical Reliability Concepts. ASME Design Engineering Conference, New York: May 17-20, 1965.
44. National Bureau of Standards, "A Guide to Tables of the Normal Probability Integral." Applied Mathematics Series, #21, Washington: U.S. Government Printing Office, 1952.
45. National Bureau of Standards Handbook 91, "Experimental Statistics," August 1, 1968.
46. National Bureau of Standards, "Probability Tables for Analysis of Extreme-Value Data," Applied Math Series, #22, Washington; U.S. Government, 1953.

47. Pearson, K; Stouffer, S.A.; and David, F.N., "Further Applications in Statistics of the  $T_m(x)$  Bessel Function." Biometrika. Volume XXIV, Parts III, IV, pp. 293-350, November 1932.
48. Pearson, K. (Editor), Tables of the Incomplete Beta Function. Biometrika Office, Cambridge Office, Cambridge University Press, 1948.
49. Pieruschka, E., Principles of Reliability. Prentice-Hall, Inc., pp. 99-115, 336-340, 1963.
50. Pirie, Alexandre I., "Linear Regression Analysis (Two Variables)," Statistics for the Engineer, SP-250, Society of Automotive Engineers, New York 1963.
51. Popp, H.G., "Reliability Through Statistical Material Property Definition" SAE Paper 580B. October, 1962.
52. Sines, G. and Waisman, J.L., Metal Fatigue. New York: McGraw-Hill, 1959.
53. Stulen, F.B. and Cummings, H.N., "Statistical Analysis of Fatigue Data." Proceedings for Short Course in Mechanical Properties of Metals. (Marin, H.U., Editor). The Pennsylvania State University, Department of Engineering Mechanics, 1958.
54. Weibull, W., Fatigue Testing and Analysis of Results. New York: Pergamon Press, 1961.
55. Weibull, W., "Statistical Distribution Function of Wide Applicability." Journal of Applied Mechanics. p. 293, September 18, 1951.
56. Weibull, W., "Statistical Representation of Fatigue Failures in Solids." Royal Institute of Technology Transactions. Stockholm: Volume 27, No. 49,
57. Wilkine, E.W.C., Cumulative Damage in Fatigue. IUTAM Colloquium on Fatigue Springer, Stockholm: p. 321, 1956.

**APPENDIX 1 TABLES OF THE DISTRIBUTION PARAMETERS OF FATIGUE STRENGTH**



A-1.1 INDEX TO DISTRIBUTION PARAMETERS  
FOR  
VARIOUS NON-FERROUS MATERIALS

<u>Material</u>	Distribution Parameters can be found: <u>Page No.</u>
<u>ALUMINUM ALLOYS</u>	
1. 1100 Aluminum	175
2. 5 Mg Aluminum	176
3. 355 Aluminum	176
4. 7.5 Zn-2.5 Mg Aluminum	177
5. M-257 Aluminum	179
6. M-276 Aluminum	180
7. 2014 Aluminum	182
8. 2014 Alclad Aluminum	187
9. R-303 Aluminum	189
10. 2020 Aluminum	189
11. 2024 Aluminum (Sheets, Bars, Extrusions, Forgings)	190
12. 2024 Alclad Aluminum	202
13. 2025 Aluminum	203
14. 2026 Aluminum	205
15. 2219 Aluminum	206
16. 2618 Aluminum	207
17. 5052 Aluminum	210
18. 5056 Aluminum	210
19. 5083 Aluminum	211
20. 5086 Aluminum	211
21. 5154 Aluminum	212

22.	6061 Aluminum	212
23.	5456 Aluminum	213
24.	7001 Aluminum	214
25.	7039 Aluminum	217
26.	7075 Aluminum (Plates and Sheets, Bars, Extrusions and Forgings)	218
27.	7075 Alclad Aluminum	228
28.	7076 Aluminum	229
29.	7106 Aluminum	230
30.	7079 Aluminum	231
31.	7178 Aluminum	234
<u>COBALT ALLOYS</u>		
32.	Stellite-31	237
33.	S-816	241
<u>COPPER ALLOYS</u>		
34.	Pure Copper	244
35.	70-30 Brass	245
36.	Cu-7.3 Al Bronze	247
37.	5.6 Al Bronze	247
38.	Al-Ni Bronze	248
39.	Phosphor Bronze	248
40.	Muntz Metal (Brass)	249
41.	Cu-6.5 Al-2.4 Fe	249
<u>MAGNESIUM ALLOYS</u>		
42.	2.5 Al Magnesium	251
43.	AZ31A Magnesium	252
44.	AZ31B Magnesium	252

45.	AZ61A Magnesium	253
46.	AZ80A-F Magnesium	254
47.	AZ81 Cast Magnesium	255
48.	HM21 Magnesium	255
49.	ZK60A Magnesium	256
<u>NICKEL ALLOYS</u>		
50.	"A" Nickel	258
51.	FS-27 Nickel Base Cermet	259
52.	Hastelloy C	259
53.	Hastelloy-R235	260
54.	Incoloy-901 (AMS-5560A)	262
55.	Inconel	263
56.	Inconel 713C	264
57.	Inconel-X (AMS-5667)	265
58.	Inconel-718	266
59.	Waspalloy	269
60.	Inconel-751 (INCO-X550)	270
61.	INOR-8	271
62.	Monel	271
63.	Nicro-Tung	272
64.	Nimonic-95	274
65.	Rene-41	276
66.	Nimonic-80	277
67.	Udimet-500	278
68.	Udimet-650	280
69.	6 Mo-Waspalloy	281

TITANIUM ALLOYS

70. Ti-A55	284
71. Ti-75A	288
72. Ti-150A	290
73. Ti-0.2 O <sub>2</sub>	291
74. Ti-0.2 C	292
75. Ti-N <sub>2</sub>	293
76. Ti-0.07 N <sub>2</sub> -0.2 O <sub>2</sub> -0.2 C	293
77. K-151A Ti Base Cermet	294
78. K-162B Ti Base Cermet	294
79. K-183A Ti Base Cermet	295
80. Ti-4 Al-3 Mo-1 V	296
81. Ti-4 Al-4 Mn	307
82. Ti-5 Al-2.5 Sn	308
83. Ti-5 Al-2.5 Sn-0.07 N <sub>2</sub>	308
84. Ti-5 Al-2.5 Sn-0.2 O <sub>2</sub>	309
85. Ti-5 Al-2.5 Sn-.2 C	309
86. Ti-5 Al-2.5 Sn-.07 N <sub>2</sub> -.2 O <sub>2</sub> -.2 C	310
87. Ti-6 Al	311
88. Ti-6 Al-4 V	313
89. Ti-6 Al-4 V-0.07 N <sub>2</sub>	315
90. Ti-6 Al-4 V-0.2 O <sub>2</sub>	316
91. Ti-6 Al-4 V-0.2 C	316
92. Ti-6 Al-4 V-.07 N <sub>2</sub> -.2 O <sub>2</sub> -.2 C	317
93. Ti-7 Al-4 Mo	317
94. Ti-7 Al-3 Mo	318

95. Ti-8 Al-1 Mo-1 V	319
96. Ti-3 Mn-0.2 O <sub>2</sub>	320
97. Ti-3 Mn-0.07 N <sub>2</sub>	321
98. Ti-3 Mn-0.2 C	321
99. Ti-3 Mn Complex	322
100. Ti-3 Mn-.07 N <sub>2</sub> -.2 O <sub>2</sub> -.2 C	325
101. Ti-4 Mn	325
102. Ti-8 Mn	326
103. Ti-30 Mo	328
104. Ti-13 V-11 Cr-3 Al	329
105. Ti-16 V-2.5 Sn	334

OTHER NON-FERROUS ALLOYS

106. Berilco #25	347
107. Commercially Pure Lead	347
108. 0.5 Ti Molybdenum	348
109. Commercially Pure Tantalum	349
110. 10 W-Tantalum	350
111. Pure Tungsten	350

A-1.2 DISTRIBUTION FUNCTIONS AND THEIR PARAMETERS USED IN TABLES

A-1.2.1 Weibull Distribution  
Density Function

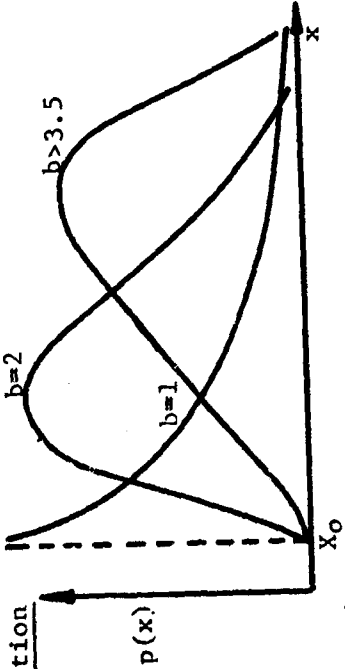

$$p(x) = \frac{b}{\theta - X_0} \left( \frac{x - X_0}{\theta - X_0} \right)^{b-1} e^{-\left( \frac{x - X_0}{\theta - X_0} \right)^b}$$

Cumulative Distribution Function

Linear Form

$$\ln \ln \frac{1}{1-P} = b [\ln(x - X_0)] + [-b \ln(\theta - X_0)]$$

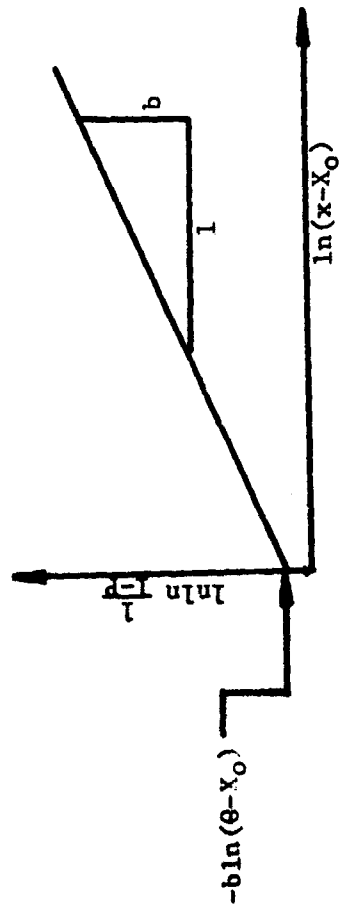

Non-Linear Form

$$P(x) = 1 - e^{-\left( \frac{x - X_0}{\theta - X_0} \right)^b}$$

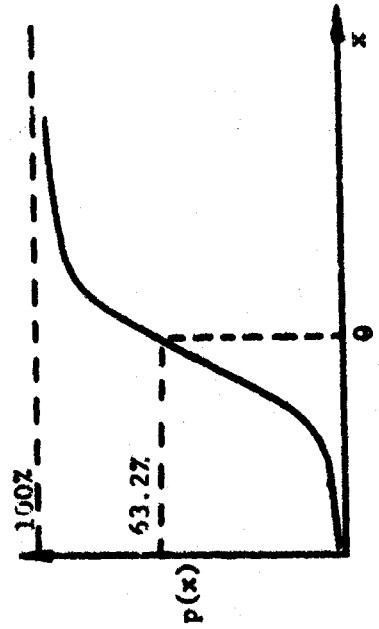

$b$  is the Weibull Slope (slope of the linear form of the distribution).  
 $\theta$  is the characteristic strength (where 63.27% of the population have fatigue strengths less than or equal to this value).  
 $X_0$  is the lower bound of fatigue strength.

A-1.2.2 Normal Distribution

Density Function

$$p(x) = \frac{1}{\sqrt{2\pi}\sigma} e^{-\frac{(x-\mu)^2}{2\sigma^2}}$$

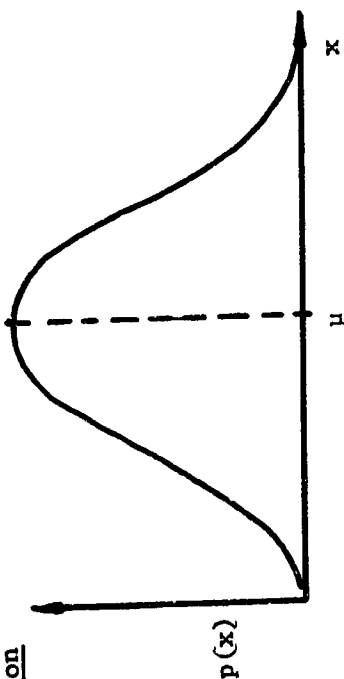

Cumulative Distribution Function

Non-Linear Form

$$P(x) = \int_{-\infty}^x \frac{1}{\sqrt{2\pi}} \sigma e^{-\frac{(x-\mu)^2}{2\sigma^2}} dx$$

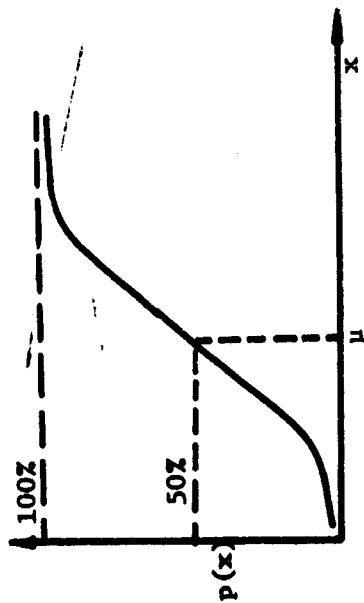

Linear Form

$$z = \left(\frac{1}{\sigma}\right) x - \frac{\mu}{\sigma}$$

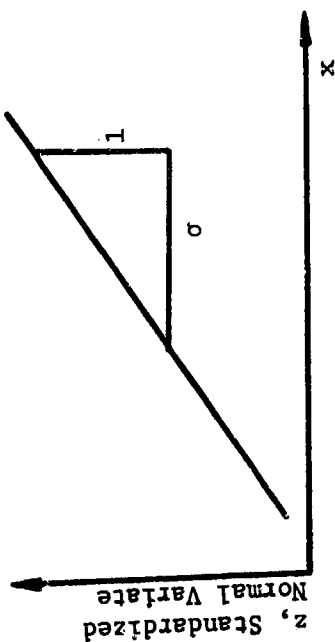

$\mu$  is the population mean (an average value).  
 $\sigma$  is the standard deviation (a measure of scatter).  
 $z$  is the standardized normal variate (number of standard deviations from the mean).

**A-1.2.3 Largest Extreme Value Distribution**  
Density Function

$$p(x) = \beta e^{-\beta(x-M)} e^{-\beta(x-M)}$$

$$= \beta e^{-\beta(x-M)} \cdot e^{-\beta(x-M)}$$

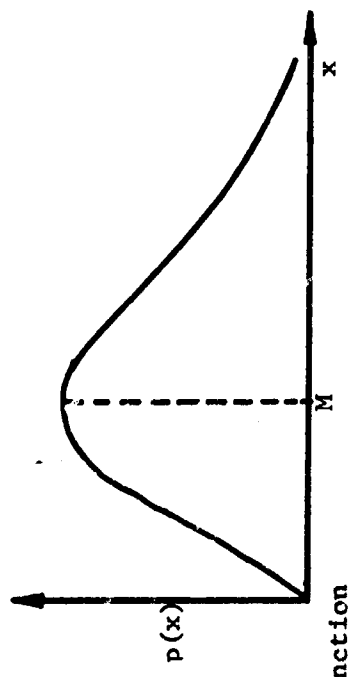

Cumulative Distribution Function

Non-Linear Form

$$P(x) = e^{-e^{-\beta(x-M)}}$$

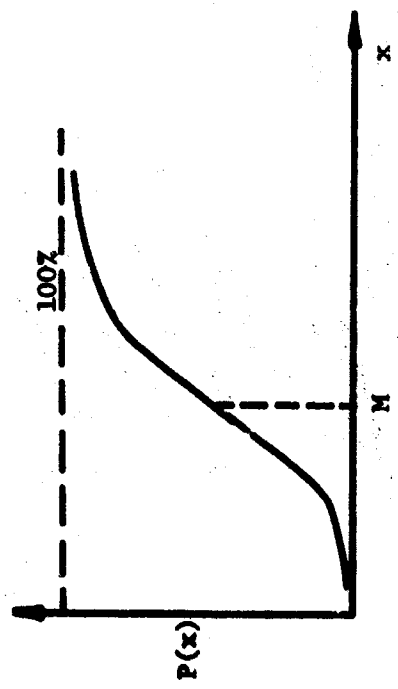

Linear Form

$$-\ln \ln \frac{1}{p} = \beta x - \beta M$$

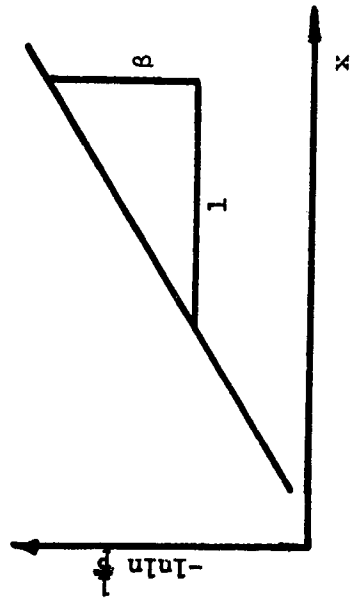

$\beta$  is the intensity function (slope of the linear form of the distribution).  
 $M$  is the mode (the most probable value).



A-1.2.4 Smallest Extreme Value Distribution

Density Function

$$p(x) = \beta e^{-\beta(x-M)} - e^{-\beta(x-M)}$$

$$= \beta e^{-\beta(x-M)} \cdot e^{-\beta(x-M)}$$

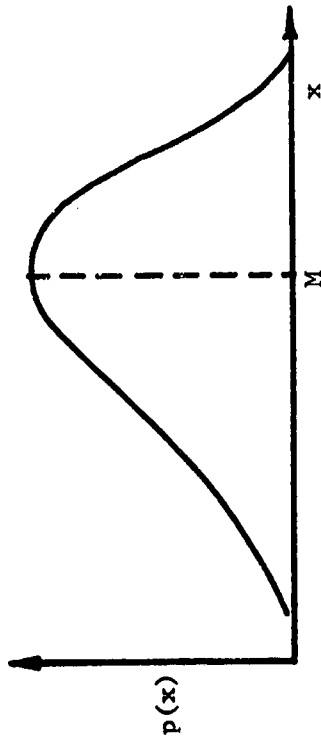

Cumulative Distribution Function

Curvilinear Form

$$P(x) = 1 - e^{-\beta(x-M)}$$

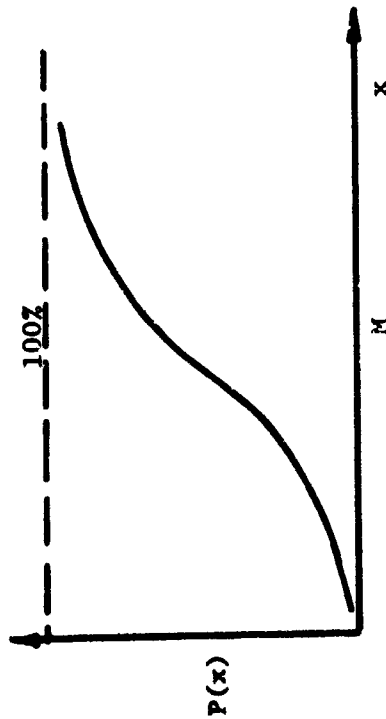

Linear Form

$$\ln \ln \frac{1}{1-P} = \beta x - \beta M$$

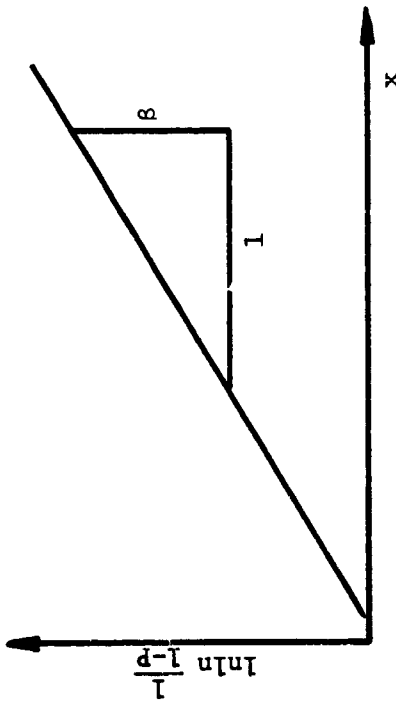

$\beta$  is the intensity function (slope of the linear form of the distribution).  
 $M$  is the mode (the most probable value).

## A-1.3 LIST OF ABBREVIATIONS AND SYMBOLS USED IN TABLES

A.C. or AC	Air Cooled	Machin.	Machined
Ann. or Anneal	Annealed	M.P. or MP	Mechanical Polishing
D.G.	Diamond Ground	O.Q. or OQ	Oil Quenched
Dist.	Statistical Distribution Function	Param.	Distribution Parameter
E.P.	Electropolished	Pe	Peening (Shot Peening)
F.C. or FC	Furnace Cooled	ppm	Parts per Million
Freq.	Frequency, Cycles per Second	RMS	Root-Mean-Squares (Micro-inches)
gr.	grit or grain	S.E.V.	Smallest Extreme Value Distribution
H.F.	Hand Finished	Sh.E.	Shaped Edges
Ho-N	Hole Notch	Sol. H.T.	Solution Heat Treated
H-Roll	Hot Rolled	SP	Specimen Configuration
H.T. or HT	Heat Treated	S.R.	Surface Rolled
$K_t$	Theoretical Notch Factor	$S_u$	Ultimate Tensile Strength
L.E.V.	Largest Extreme Value Distribution	$S_y$	Yield Strength in Tension
Longi.	Longitudinal	Temp.	Temperature, °F
Long Transv.	Long Transverse	Transv.	Transverse
LTB	Lathe Turned or/and Bored	W.Q. or WQ	Water Quenched

## A-1.4 COMPOSITION OF THE NON-FERROUS MATERIALS

I. ALUMINUM ALLOYS

<u>Alloy</u>	<u>Percent Composition</u>	
1. 1100 ALUMINUM	99.7 Al	Nominal
2. 5 Mg ALUMINUM	.21 Fe, .58 Si, 5.02 Mg, .26 Mn, Balance Al	Actual
3. 355 ALUMINUM	5 Si, 1.3 Cu, .5 Mg, Balance Al	Nominal
4. 7.5 Zn - 2.5 Mg ALUMINUM	7.5 Zn, 2.5 Mg, Balance Al	Nominal
5. M-257 ALUMINUM	Not Reported	
6. M-276 ALUMINUM	Not Reported	
7. 2014 ALUMINUM	4.46 Cu, .43 Fe, .95 Si, .8 Mn, .44 Mg, .072 Zn, Balance Al	Nominal
8. 2014 ALCLAD ALUMINUM	4.46 Cu, .43 Fe, .95 Si, .8 Mn, .44 Mg, .072 Zn, Balance Al	Nominal
9. R-303 ALUMINUM	6.4 Zn, 2.5 Mg, 1.2 Cu, Balance Al	Nominal
10. 2020 ALUMINUM	Not Reported	
11. 2024 ALUMINUM	4.5 Cu, 1.5 Mg, .6 Mn, Balance Al	Nominal
12. 2024 ALGLAD ALUMINUM	4.5 Cu, 1.5 Mg, .6 Mn, Balance Al	Nominal
13. 2025 ALUMINUM	4.28 Cu, .36 Fe, .77 Mn, .76 Si, Balance Al	Actual
14. 2026 ALUMINUM	.5 Mg, .75 Si, .75 Mn, 4.5 Cu, Balance Al	Actual
15. 2219 ALUMINUM	.2 Si, .3 Fe, 6 Cu, .3 Mn, .02 Mg, .1 Zn, Balance Al	Actual
16. 2618 ALUMINUM	2.4 Cu, .25 Si, 1 Fe, 1.5 Mg, .08 Ti, .1 Ni, Balance Al	Actual
17. 5052 ALUMINUM	2.5 Mg, .25 Cr, Balance Al	Nominal
18. 5056 ALUMINUM	5.2 Mg, .1 Mn, .1 Cr, Balance Al	Nominal
19. 5083 ALUMINUM	.27 Fe, .15 Si, .06 Cu, .76 Mn, 4.48 Mg, .01 Zn, .09 Cr, .01 Ti, Balance Al	Actual

<u>Alloy</u>	<u>Percent Composition</u>	
20. 5086 ALUMINUM	4.0 Mg, .5 Mn, Balance Al	Nominal
21. 5154 ALUMINUM	3.5 Mg, .25 Cr, Balance Al	Nominal
22. 6061 ALUMINUM	1. Mg, .6 Si, .25 Cu, .25 Cr, Balance Al	Nominal
23. 5456 ALUMINUM	5. Mg, .7 Mn, .15 Cu, .15 Cr, Balance Al	Nominal
24. 7001 ALUMINUM	.11 Si, .12 Fe, 2.1 Cu, 3.03 Mg, 7.59 Zn, .2 Cr, .01 Ti, Balance Al	Actual
25. 7039 ALUMINUM	Not Reported	
26. 7075 ALUMINUM	5.5 Zn, 2.5 Mg, 1.5 Cu, .3 Cr, Balance Al	Nominal
27. 7075 ALCLAD ALUMINUM	5.5 Zn, 2.5 Mg, 1.5 Cu, .3 Cr, Balance Al	Nominal
28. 7076 ALUMINUM	.6 Cu, 7.6 Zn, 1.6 Mg, .6 Mn, .1 Ti, .5 Fe, .25 Si, Balance Al	Actual
29. 7106 ALUMINUM	.35 Si, .35 Fe, .1 Cu, .2 Mn, 2 Mg, 4 Zn, .1 Cr, Balance Al	Actual
30. 7079 ALUMINUM	4.3 Zn, 3.3 Mg, .6 Cu, .2 Mn, .2 Cr, Balance Al	Nominal
31. 7178 ALUMINUM	6.8 Zn, 2.7 Mg, 2.0 Cu, .3 Cr, Balance Al	Nominal
<b>II. <u>COBALT ALLOYS</u></b>		
32. STELLITE-31	4.5 C, 24.8 Cr, .42 Mn, 10.4 Ni, .93 Si, 1.39 Fe, .01 P, .010 S, .03 Al, 7.26 W, Balance Co	Actual
33. S-816	.397 C, 1.12 Mn, .50 Si, 19.42 Cr, 20.62 Ni, 4.1 Mo, .018 S, .012 P, 2.86 Co, 4.03 W, 2.99 Fe, 1.09 Ta, 42.9 Co	Actual
<b>III. <u>COPPER ALLOYS</u></b>		
34. PURE COPPER	99.98 Cu	Nominal
35. 70-30 BRASS	70 Cu, 30 Zn	Nominal

<u>Alloy</u>	<u>Percent Composition</u>	
36. Cu-73 Al BRONZE	92.7 Cu, 7.3 Al	Nominal
37. 5.6 Al BRONZE	94.4 Cu, 5.6 Al	Nominal
38. Al-Ni BRONZE	81.75 Cu, .71 Mn, 2.86 Fe, 4.69 Ni, 9.90 Al	Actual
39. PHOSPHOR BRONZE	94.05 Cu, .18 P, 4.2 Sn, .05 Pb	Actual
40. MUNTZ METAL (BRASS)	60.3 Cu, 39.7 Zn	Actual
41. Cu - 6.5 Al - 2.4 Fe	91.1 Cu, 6.5 Al, 2.4 Fe	Nominal
IV. <u>MAGNESIUM ALLOYS</u>		
42. 2.5 Al MAGNESIUM	2.5 Al, 97.5 Mg	Nominal
43. AZ31A MAGNESIUM	3 Al, 1 Zn, .2 Mn, Balance Mg	Nominal
44. AZ31B MAGNESIUM	3 Al, 1 Zn, .2 Mn, Balance Mg	Nominal
45. AZ61A MAGNESIUM	5.5 Al, 1 Zn, .2 Mn, Balance Mg	Nominal
46. AZ80A-F MAGNESIUM	8.5 Al, .5 Zn, Balance Mg	Nominal
47. AZ81 CAST MAGNESIUM	7.5 Al, .7 Zn, .15 Mn, Balance Mg	Nominal
48. HM21 MAGNESIUM	2 Th, .5 Mn	Nominal
49. ZK60A MAGNESIUM	5.6 Zn, .66 Zr, Balance Mg	Nominal
V. <u>NICKEL ALLOYS</u>		
50. "A" NICKEL	99.35 Ni + Co	Nominal
51. PS-27 CERMET	34.3 Ti, 50 Ni, 6.2 Cr, 9.5 C	Actual
52. HASTELLOY C	.05 C, .48 Mn, .64 Si, 56.6 Ni, 15.5 Cr, 16.2 Mo, 5.7 Fe, 3.8 W	Actual
53. HASTELLOY-R235	.17 C, .017 S, 2.06 Al, 2.55 Ti, 5.31 Mo, 15.51 Cr, .27 Co, 9.95 Fe, .22 Si, .03 Mn, Balance Ni	Actual
54. INCOLOY-901	12.41 Cr, 6.14 Mo, .18 Co, 2.67 Ti, .13 Al, 43.20 Ni, Balance Fe	Actual
55. INCONEL	.02 C, .13 Mn, 6.81 Fe, .01 S, .17 Si, .06 Cu, 75.85 Ni, 15.54 Cr	Actual

<u>Alloy</u>	<u>Percent Composition</u>	
56. INCONEL-713C	11.9 Cr, .86 Fe, .49 Si, .13 Mn, .11 C, 5.0 Mo, 5.6 Al, .52 Ti, 2.1 Cb, Balance Ni	Actual
57. INCONEL-X	.05 C, .57 Mn, 6.77 Fe, .29 Si .08 Cu, 72.85 Ni, 14.98 Cr, .72 Al, 2.54 Ti, 1.12 (Cb + Ta)	Actual
58. INCONEL-718	.04 C, .20 Mn, .20 Si, 52.5 Ni, 19 Cr, 3 Mo, 18 Fe, .8 Ti, 5.2 Cb, .6 Al	Actual
59. WASPALLOY	.1 Si, .1 Mn, 19.5 Cr, .55 Fe, 4.39 Mo, 13.5 Co, 2.87 Ti, 1.29 Al, Balance Ni	Actual
60. INCONEL-751	.05 C, .73 Mn, .28 Si, 14.92 Cr, 2.5 Ti, 1.16 Al, 6.59 Fe, .03 Cu, 1.03 (Cb + Ta), Balance Ni	Actual
61. INOR-8	Not Reported	
62. MONEL	31.2 Cu, 66.9 Ni	Actual
63. NICRO-TUNG	.1 C, .05 B, .05 Zr, 12 Cr, 10 Co, 8 W, 4 Al, 4 Ti, Balance Ni	Actual
64. NIMONIC-95	.08 C, .36 Si, .06 Cu, .31 Fe, .08 Mn, 19.8 Cr, 2.98 Ti, 1.74 Al, 17.8 Co, Balance Ni	Actual
65. RENE-41	19 Cr, 11 Co, 10 Mo, 3 Ti, 1.5 Al, Balance Ni	Nominal
66. NIMONIC-80A	.08 C, .66 Si, .05 Cu, .3 Fe, .06 Mn, 19.7 Cr, 2.4 Ti, 1.18 Al, 1.0 Co, Balance Ni	Actual
67. UDIMET-500	18.75 Cr, .57 Fe, 4.25 Mo, 17.61 Co, 3.09 Ti, 3.15 Al, Balance Ni, .1 Cu	Nominal
68. UDIMET-650	.61 Al, 1.05 Ti, 2.90 Mo, 17.5 Cr, .1 Co, 17.2 Fe, 6.20 Ta, 2.75 W, .1 Si, .21 Mn, Balance Ni	Actual
69. 6 Mo WASPALLOY	.136 C, .56 Mn, .31 Si, 19.68 Cr, 6.32 Mo, 13.5 Co, 2.59 Ti, 1.04 Al, 2.5 Fe, Balance Ni	Actual

<u>Alloy</u>	<u>Percent Composition</u>	
VI. <u>TITANIUM ALLOYS</u>		
70. Ti-A55	.051 C, .058 O <sub>2</sub> , .01 Fe, Balance Ti	Actual
71. Ti-75A	Not Reported	
72. Ti-150A	2.6 Cr, 1.3 Fe, 0.2 O <sub>2</sub> , Balance Ti	Nominal
73. Ti-0.2 O <sub>2</sub>	.25 O <sub>2</sub> , 1.0 W, .061 C, Balance Ti	Actual
74. Ti-0.2 C	.2 C, Balance Ti	Nominal
75. Ti-N <sub>2</sub>	.2 N <sub>2</sub> , 1.0 W, Balance Ti	Actual
76. Ti-.07 N <sub>2</sub> -.2 O <sub>2</sub> -.2 C	.26 C, .08 N <sub>2</sub> , .1 Fe, .19 O <sub>2</sub> , Balance Ti	Actual
77. K-151A CERMET	58 Ti, 19 Ni, 7.5 Nb, .5 Ta, 15 C	Actual
78. K-162B CERMET	52 Ti, 25 Ni, 5 Mo, 4.5 Nb, 3 Ta, 13.2 C	Actual
79. K-183A CERMET	41 Ti, 32 Ni, 3 Mo, 2.5 Al, 7.5 Nb, 2.5 Cr, .5 Ta, 12 C	Actual
80. Ti-4 Al-3 Mo-1 V	4 Al, 3 Mo, Balance Ti	Nominal
81. Ti-4 Al-4 Mn	4 Al, 4 Mn, Balance Ti	Nominal
82. Ti-5 Al-2.5 Sn	5 Al, 2.5 Sn, Balance Ti	Nominal
83. Ti-5 Al-2.5 Sn-.07 N <sub>2</sub>	.04 C, .07 N <sub>2</sub> , .08 Fe, .12 O <sub>2</sub> 5.04 Al, 2.5 Sn, Balance Ti	Nominal
84. Ti-5 Al-2.5 Sn-.2 O <sub>2</sub>	.05 C, .007 N <sub>2</sub> , .1 Fe, .2 O <sub>2</sub> , .5 Al, 2.5 Sn, Balance Ti	Nominal
85. Ti-5 Al-2.5 Sn-.2 C	.2 C, .05 O <sub>2</sub> , .007 N <sub>2</sub> , .1 Fe, .5 Al, 2.5 Sn, Balance Ti	Nominal
86. Ti-5 Al-2.5 Sn COMPLEX	Complex of the previous three	Nominal
87. Ti-6 Al	.06 C, .035 N <sub>2</sub> , .578 Al, Balance Ti	Actual
88. Ti-6 Al-4 V	.02 C, .18 Fe, .011 N <sub>2</sub> , 6 Al 4 V, Balance Ti	Nominal
89. Ti-6 Al-4 V-.07 N <sub>2</sub>	Not Reported	

<u>Alloy</u>	<u>Percent Composition</u>	
90. Ti-6 Al- 4V-.2 O <sub>2</sub>	.07 C, .005 N <sub>2</sub> , .12-.13 Fe, 67-82 H <sub>2</sub> ppm, 201 O <sub>2</sub> , 6.03-6.37 Al, 4.18 V, Balance Ti	Actual
91. Ti-6 Al-4 V-.2 C	.23-.24 C, .014-.016 N <sub>2</sub> , .10-.13 Fe, 75-92 H <sub>2</sub> ppm, .113-.120 O <sub>2</sub> , 6.10-6.35 Al, 4.12-4.24 V, Bal. Ti	Actual
92. Ti-6 Al-4 V-.07 N <sub>2</sub> -.2 O <sub>2</sub> -.2 C	.19-.22 C, .052-.053 N <sub>2</sub> , .09-.10 Fe, 62-63 H <sub>2</sub> ppm, .194-.201 O <sub>2</sub> , 5.74-6.18 Al, 4.12-4.30 V, Bal. Ti	Actual
93. Ti-7 Al-4 Mo	Not Reported	
94. Ti-7 Al-3 Mo	.020 C, .03 Fe, 7.0 Al, 2.7 Mo, .004 H <sub>2</sub> , Balance Ti	Actual
95. Ti-8 Al-1 Mo-1 V	.023 C, .09 Fe, .013 N <sub>2</sub> , 7.6 Al, 1.0 V, 1.1 Mo, .010-.014 H <sub>2</sub> , Balance Ti	Actual
96. Ti-3 Mn-.2 O <sub>2</sub>	.02-.03 C, .016-.034 N <sub>2</sub> , .80-.83 Fe, 36-39 H <sub>2</sub> ppm, .150-.175 O <sub>2</sub> , 1.00-1.06 V, 3.0-3.2 Mn, .90-1.04 Cr, 1.15-1.20 Mo, Balance Ti	Actual
97. Ti-3 Mn-.07 N <sub>2</sub>	.03 C, .052-.053 N <sub>2</sub> , .88-1.06 Fe, 43 H <sub>2</sub> ppm, .122-1.44 O <sub>2</sub> , 1.00-1.06 V, 2.50-2.90 Mn, .96-1.08 Cr, 1.03 Mo, Balance Ti	Actual
98. Ti-3 Mn-.2 C	.21-.22 C, .014-.017 N <sub>2</sub> , 1.08-1.12 Fe, 96-108 H <sub>2</sub> ppm, .103-.148 O <sub>2</sub> , 1.29-1.35 V, 3.00-3.05 Mn, .94-.98 Cr, 1.35-1.36 Mo, Balance Ti	Actual
99. Ti-3 Mn COMPLEX	.02-.07 C, .011-.012 N <sub>2</sub> , .86-.88 Fe, 48-64 H <sub>2</sub> ppm, .091-.082 O <sub>2</sub> , 1.06-1.24 V, 3.08 Mn, .80-.96 Cr, 1.12-1.20 Mo, Balance Ti	Actual
100. Ti-3 Mn-.07 N <sub>2</sub> -.2 O <sub>2</sub> -.2 C	.11-.15 C, .056-.057 N <sub>2</sub> , .98-1.0 Fe, 54-58 H <sub>2</sub> ppm, .189-.216 O <sub>2</sub> , 1.00-1.18 V, 2.5-2.6 Mn, .94-.96 Cr, 1.26-1.38 Mo, Balance Ti	Actual
101. Ti-4 Mn	.14 C, .02 N <sub>2</sub> , 4.20 Mn, Bal. Ti	Actual
102. Ti-8 Mn	8 Mn, 92 Ti	Nominal



<u>Alloy</u>	<u>Percent Composition</u>	
103. Ti-30 Mo	.011-.016 C, .065-.069 N <sub>2</sub> , 29.88-30.17 Mo, Balance Ti	
104. Ti-13 V-11 Cr-3 Al	.029 C, .14 Fe, .028 N <sub>2</sub> , 3.0 Al, 13.5 V, 11.2 Cr, .010 H <sub>2</sub> , Bal. Ti	Actual
105. Ti-16 V-2.5 Sn	16 V, 2.5 Sn, Balance Ti	Nominal
VII. <u>OTHER NON-FERROUS ALLOYS</u>		
106. BERILCO #25	Not Reported	
107. PURE LEAD	99.995 Pb	Nominal
108. 0.5 Ti-MOLYBDENUM	0.46 Ti, 0.02 C, Balance Mo	Actual
109. PURE TANTALUM	.08 Cb, .01 W, .01 Fe, Balance Ta	Actual
110. 10 W-TANTALUM	90 Ta, 10 W	Nominal
111. PURE TUNGSTEN	Not Reported	

A-1.5 TABLES

A-1.5.1 Aluminum Alloys

S<sub>u</sub> = 10 ksi  
 S<sub>y</sub> = 9 ksi

1100 ALUMINUM

Composition: See Page 166.  
 (\*) Extrapolated Values

Code No.	TEST CONDITIONS				FATIGUE STRENGTH DISTRIBUTIONS AND THEIR PARAMETERS												
	Heat Treat	Surt. Fin.	Freq.	Temp °F	K <sub>t</sub>	Other	DIST.	Param.	LIFE IN CYCLES								
									1x10 <sup>3</sup>	1x10 <sup>4</sup>	5x10 <sup>4</sup>	1x10 <sup>5</sup>	5x10 <sup>5</sup>	1x10 <sup>6</sup>	5x10 <sup>6</sup>	1x10 <sup>7</sup>	1x10 <sup>8</sup>

ROTARY BEAM BENDING

Miscellaneous

1				80	1.0	Forged & Swaged	Webull	b <sub>0</sub> q <sub>0</sub>		3.470	3.460	3.460	3.460	3.460	3.460	3.460	3.460*
										7.318	5.416	4.757	3.521	3.093	2.289	2.010	1.307
										3.077	2.284	2.006	1.484	1.304	.9653	.8479	.5512

PLATE BENDING (Completely Reversed)

Miscellaneous

2	HT-1			80	V-Notch		Webull	b <sub>0</sub> q <sub>0</sub>	1.122*	1.076*	1.048*	1.037*	1.141	1.133	1.132	1.132	1.132*
									4.734	3.816	3.282	3.076	2.657	2.491	2.144	2.010	1.623
									3.367	2.736	2.364	2.220	1.884	1.768	1.522	1.427	1.152

AXIAL (Completely Reversed)

Miscellaneous

3				80	1.0		Webull	b <sub>0</sub> q <sub>0</sub>		5.295	4.969	5.290	5.290	5.290	4.969*	4.969*	5.290*
										9.201	8.342	7.998	7.252	6.953	6.303	6.043	5.253
										6.554	6.068	5.699	5.167	4.954	4.585	4.396	3.743

HT-1: 1 hour at 320°C in Vacuum

Composition: See Page 166  
(\* Extrapolated Values)

5 Mg ALUMINUM

S<sub>y</sub> = 50 ksi  
S<sub>u</sub> = 40 ksi

Code No.	TEST CONDITIONS				FATIGUE STRENGTH DISTRIBUTIONS AND THEIR PARAMETERS												
	Heat Treat	Surf. Fin.	Freq.	Temp °K	K <sub>t</sub>	Other	DIST.	Param.	LIFE IN CYCLES								
									1x10 <sup>3</sup>	1x10 <sup>4</sup>	5x10 <sup>4</sup>	1x10 <sup>5</sup>	5x10 <sup>5</sup>	1x10 <sup>6</sup>	5x10 <sup>6</sup>	1x10 <sup>7</sup>	1x10 <sup>8</sup>

PLATE BENDING (Completely Reversed)  
Effect of Stress Concentration

4				80					2.476	2.559	2.522	2.507	2.506	2.506	2.506*	2.506*	2.506*	2.506*
									38.67	28.91	23.58	21.61	17.63	16.15	13.18	12.07	9.026	
									26.01	19.24	15.78	14.48	11.81	10.82	8.834	8.093	6.049	
5				80					2.827	2.806	2.817	2.958	2.823	2.775	2.898	2.866	2.827*	
									44.70	30.01	22.72	20.16	15.25	13.53	10.24	9.088	6.102	
									32.82	22.08	16.69	14.62	11.20	9.982	7.474	6.649	4.480	

S<sub>u</sub> = 30 ksi

Composition: See Page 166  
(\* Extrapolated Values)

355 ALUMINUM

PLATE BENDING (Completely Reversed)  
Effect of Surface Finish

6				80						2.699*	2.603	2.589	2.589	2.589	2.589*	2.589*	2.589*	2.589*
										28.12	21.09	18.63	13.98	12.35	9.272	8.193	5.431	
										22.23	16.78	14.84	11.13	9.841	7.384	6.525	4.326	
7				80							.5511*	.6526	.9662	1.144	1.694*	2.005*	3.516*	
											25.52	21.55	14.55	12.29	8.302	7.011	3.999	

Composition: See Page 166  
 (\*) Extrapolated Values

7.5 Zn - 2.5 Mg ALUMINUM

S<sub>y</sub> = 40-60 ksi  
 S<sub>u</sub> = 15-60 ksi

Code No.	TEST CONDITIONS			FATIGUE STRENGTH DISTRIBUTIONS AND THEIR PARAMETERS													
	Heat Treat	Surf. Fin.	Freq.	Temp °F	K <sub>t</sub>	Other	DIST.	Param.	LIFE IN CYCLES								
									1x10 <sup>3</sup>	1x10 <sup>4</sup>	5x10 <sup>4</sup>	1x10 <sup>5</sup>	5x10 <sup>5</sup>	1x10 <sup>6</sup>	5x10 <sup>6</sup>	1x10 <sup>7</sup>	1x10 <sup>8</sup>

ROTARY BEAM BENDING  
 Effect of Environment

Code No.	Heat Treat	Surf. Fin.	Freq.	Temp °F	K <sub>t</sub>	Other	DIST.	Param.	1x10 <sup>3</sup>	1x10 <sup>4</sup>	5x10 <sup>4</sup>	1x10 <sup>5</sup>	5x10 <sup>5</sup>	1x10 <sup>6</sup>	5x10 <sup>6</sup>	1x10 <sup>7</sup>	1x10 <sup>8</sup>
8	HT-2			80	1.0	Air Fatigue	S.E.V.	M	.4048* 47.09	.5065* 37.64	.5923* 32.19	.6336* 30.09	.7410 25.73	.7927 24.05	.9270* 20.56	.9917* 19.22	1.240* 15.36
9	HT-2			80	1.0	Corro-Fatigue	L.E.V.	M	.1403* 57.47	.2365* 34.09	.3406 23.67	.3986 20.22	.5742 14.04	.6719 12.00	.9679 8.331	1.132 7.119	1.909* 4.224
10	HT-3			80	1.0	Air Fatigue	L.E.V.	M	.3660* 57.49	.4935* 42.64	.6081* 34.61	.6653* 31.63	.8198 25.67	.8969 23.46	1.105 19.04	1.209* 17.40	1.630* 12.91
11	HT-3	Electropolished		80	1.0	Corro-Fatigue	Wetbulb	X θ q	2.943* 59.67 41.73	2.866* 36.99 26.08	3.030* 26.49 18.35	2.959 22.94 16.01	3.015 16.43 11.40	2.972 14.22 9.919	2.891 10.18 7.162	2.874 8.819 6.213	2.874* 5.468 3.853
12	HT-4			80	1.0	Air Fatigue	Wetbulb	X θ q	3.271* 44.25 35.95	3.525* 33.36 26.72	3.404* 27.37 22.07	3.359* 25.13 20.32	3.268 20.62 16.76	3.233 18.94 15.42	3.188* 15.54 12.69	3.526* 14.28 11.43	3.526* 10.76 8.622
13	HT-4			80	1.0	Corro-Fatigue	Normal	θ	5.311* 51.946	3.504* 34.27	2.620* 25.63	2.312 22.61	1.729 16.91	1.525 14.92	1.141 11.16	1.006 9.847	.6643* 6.497

HT-2: Solution Heat Treated 450°C, W.Q.  
 HT-3: Solution Heat Treated 450°C, W.Q., Aged 0.1 day 150°C

Composition: See Page 166  
 (\*) Extrapolated Values

7.5 Zn - 2.5 Mg ALUMINUM (Cont'd)

S<sub>u</sub> = 40-60 ksi  
 S<sub>y</sub> = 15-60 ksi

+Code No.	TEST CONDITIONS				FATIGUE STRENGTH DISTRIBUTIONS AND THEIR PARAMETERS												
	Heat Treat	Surf. Fin.	Freq.	Temp.	R <sub>r</sub>	Other	DIST.	Param.	LIFE IN CYCLES								
									1x10 <sup>3</sup>	1x10 <sup>4</sup>	5x10 <sup>4</sup>	1x10 <sup>5</sup>	5x10 <sup>5</sup>	1x10 <sup>6</sup>	5x10 <sup>6</sup>	1x10 <sup>7</sup>	1x10 <sup>8</sup>

ROTARY BEAM BENDING  
 Effect of Heat Treatment

Code No.	Heat Treat	Surf. Fin.	Freq.	Temp.	R <sub>r</sub>	Other	DIST.	Param.	LIFE IN CYCLES								
									1x10 <sup>3</sup>	1x10 <sup>4</sup>	5x10 <sup>4</sup>	1x10 <sup>5</sup>	5x10 <sup>5</sup>	1x10 <sup>6</sup>	5x10 <sup>6</sup>	1x10 <sup>7</sup>	1x10 <sup>8</sup>
14	HT-2			80	1.0		S.E.V.	β	.4048*	.5065*	.5923*	.6336*	.7410	.7927	.9270*	.9917*	1.240*
									47.09	37.64	32.19	30.09	25.73	24.05	20.56	19.22	15.36
15	HT-3			80	1.0	Alt Fatigue	L.E.V.	β	.3660*	.4935*	.6081*	.6653*	.8198	.8969	1.105	1.209*	1.630*
									57.49	42.64	34.61	31.63	25.67	23.46	19.04	17.40	12.91
16	HT-4	Electropolished		80	1.0		Wetbulb	ρ	3.271*	3.525*	3.404*	3.359*	3.268	3.233	3.188*	3.526*	3.526*
									44.25	33.36	27.37	25.13	20.62	18.94	15.54	14.28	10.76
									35.95	26.72	22.07	20.32	16.76	15.42	12.69	11.43	8.622
17	HT-2			80	1.0	Corrosion Fatigue	L.E.V.	β	.1403*	.2365*	.3406	.3986	.5742	.6719	.9679	1.132	1.909*
									57.47	34.09	23.67	20.22	14.04	12.00	8.331	7.119	4.224
18	HT-3			80	1.0		Wetbulb	b	2.943*	2.866*	3.030*	2.959	3.015	2.972	2.891	2.874	2.874*
									59.67	36.99	26.49	22.94	16.43	14.22	10.18	8.819	5.468
									41.73	26.08	18.35	16.01	11.40	9.919	7.162	6.213	3.853
19	HT-4			80	1.0		Normal	n	5.311*	3.504*	2.620*	2.312	1.729	1.525	1.141	1.006	.6643*
									51.946	34.27	25.63	22.61	16.91	14.92	11.16	9.847	6.497

HT-4: Solution Heat Treated, 450°C, W.Q., Aged, 10 days at 150°C

Composition: See Page 166  
 (\*) Extrapolated Values

M - 257 ALUMINUM

S<sub>u</sub> = 37 ksi  
 S<sub>y</sub> = 24 ksi

+Code No.	TEST CONDITIONS				FATIGUE STRENGTH DISTRIBUTIONS AND THEIR PARAMETERS										
	Heat Treat	Surt. Fin.	Freq.	Temp	Other	DIST.	Param.	LIFE IN CYCLES							
								1x10 <sup>3</sup>	1x10 <sup>4</sup>	5x10 <sup>4</sup>	1x10 <sup>5</sup>	5x10 <sup>5</sup>	1x10 <sup>6</sup>	5x10 <sup>6</sup>	1x10 <sup>7</sup>

AXIAL (Completely Reversed)  
 Effect of Stress Concentration

Code No.	Heat Treat	Surt. Fin.	Freq.	Temp	Other	DIST.	Param.	1x10 <sup>3</sup>	1x10 <sup>4</sup>	5x10 <sup>4</sup>	1x10 <sup>5</sup>	5x10 <sup>5</sup>	1x10 <sup>6</sup>	5x10 <sup>6</sup>	1x10 <sup>7</sup>	1x10 <sup>8</sup>
20	Streted		30	800		S.E.V.	β M	.5506* 21.66	.7611* 15.67	.9544* 12.49	1.052 11.33	1.319 9.040	1.454 8.201	1.824 6.539	2.010* 5.932	2.779* 4.291
21	Streted		30	800		S.E.V.	β M	.6087* 13.02	.9144* 8.570	1.215 6.523	1.373 5.771	1.825 4.342	2.063 3.841	2.742 2.890	3.100 2.557	4.657* 1.702
22	Mechanical Polish 8 RMS		30	900		Wetbulb	ρ X <sub>o</sub>	2.152* 13.33 10.90	2.152* 10.57 8.648	2.152 8.992 7.353	2.152 8.385 6.857	2.152 7.130 5.830	2.152 6.649 5.437	2.152 5.653 4.623	2.152 5.272 4.311	2.152* 4.180 3.418
23	Streted		30	900		L.E.V.	β M	.2987* 15.70	.5511* 8.510	.8456 5.546	1.016 4.612	1.560 3.006	1.876 2.499	2.878 1.629	3.461 1.354	6.387* .7343

Effect of Test Temperature

Code No.	Heat Treat	Surt. Fin.	Freq.	Temp	Other	DIST.	Param.	1x10 <sup>3</sup>	1x10 <sup>4</sup>	5x10 <sup>4</sup>	1x10 <sup>5</sup>	5x10 <sup>5</sup>	1x10 <sup>6</sup>	5x10 <sup>6</sup>	1x10 <sup>7</sup>	1x10 <sup>8</sup>
24	Streted		30	800		S.E.V.	β M	.5506* 21.66	.7611* 15.67	.9544* 12.49	1.052 11.33	1.319 9.040	1.454 8.201	1.824 6.539	2.010* 5.932	2.779* 4.291
25	Streted	M.P. - 8 RMS	30	900		Wetbulb	ρ X <sub>o</sub>	2.152* 13.33 10.90	2.152* 10.57 8.648	2.152 8.992 7.353	2.152 8.385 6.857	2.152 7.130 5.830	2.152 6.649 5.437	2.152 5.653 4.623	2.152 5.272 4.311	2.152* 4.180 3.418



Composition: See Page 166  
 (\*) Extrapolated Values

M-257 ALUMINUM (Cont'd)

S<sub>y</sub> = 37 ksi  
 S<sub>u</sub> = 24 ksi

+Code No.	TEST CONDITIONS				FATIGUE STRENGTH DISTRIBUTIONS AND THEIR PARAMETERS										
	Heat Treat	Surf. Fin.	Freq.	Temp.	Other	Dist.	LIFE IN CYCLES								
							1x10 <sup>3</sup>	1x10 <sup>4</sup>	5x10 <sup>4</sup>	1x10 <sup>5</sup>	5x10 <sup>5</sup>	1x10 <sup>6</sup>	5x10 <sup>6</sup>	1x10 <sup>7</sup>	1x10 <sup>8</sup>

AXIAL (Completely Reversed)  
 Effect of Test Temperature

26	Stirred	M.P. - 8 RMS	30	800	3.0											
						S.F.V.	β	.9144*	1.215	1.373	1.825	2.063	2.742	3.100	4.657*	
							M	13.02	8.670	5.771	4.342	3.841	2.890	2.557	1.702	
27	Stirred	M.P. - 8 RMS	30	900	3.0											
						L.F.V.	β	.2987*	.8456	1.016	1.560	1.876	2.878	3.461	6.387*	
							M	15.70	8.510	4.612	3.006	2.499	1.629	1.354	.7343	

Composition: See Page 166  
 (\*) Extrapolated Values

M - 276 ALUMINUM

S<sub>y</sub> = 51 ksi  
 S<sub>u</sub> = 39 ksi

AXIAL (Completely Reversed)  
 Effect of Stress Concentration

28	Stirred	M.P. - 8 RMS	30	800	1.0											
						Wetball	β	3.390*	3.546*	3.544*	3.544	3.544	3.544	3.544	3.544*	
							σ <sub>D</sub>	18.64	15.28	12.52	10.90	10.26	8.932	8.413	6.894	
							σ <sub>P</sub>	12.79	10.32	8.466	7.366	6.938	6.036	5.685	4.659	
29	Stirred	M.P. - 8 RMS	30	800	3.0											
						Wetball	β	2.061*	2.061	2.061	2.061	2.061	2.061	2.061	2.061*	
							σ <sub>D</sub>	12.24	8.768	6.276	4.968	4.492	3.556	3.215	2.301	
							σ <sub>P</sub>	8.568	6.133	4.390	3.475	3.142	2.487	2.249	1.610	

M-276 ALUMINUM (Cont'd)  
Composition: See Page 166  
(\* Extrapolated Values)

S<sub>y</sub> = 51 ksi  
S<sub>u</sub> = 34 ksi

+Code No.	TEST CONDITIONS				Heat Treat	Surf. Fin.	Freq.	Temp	R <sub>t</sub>	Other	DISTR.	Param	FATIGUE STRENGTH DISTRIBUTIONS AND THEIR PARAMETERS								
	LIFE IN CYCLES																				
													1x10 <sup>3</sup>	1x10 <sup>4</sup>	5x10 <sup>4</sup>	1x10 <sup>5</sup>	5x10 <sup>5</sup>	1x10 <sup>6</sup>	5x10 <sup>6</sup>	1x10 <sup>7</sup>	1x10 <sup>8</sup>

AXIAL (Completely Reversed)  
Effect of Stress Concentration

30	Sintered												β	.7099*	.9066*	1.075*	1.157*	1.373	1.478	1.753*	1.887*	2.410*
													θ	17.77	13.91	11.73	10.89	9.187	8.535	7.194	6.684	5.234
31	M.P. - 8 RMS												α <sub>c</sub>	1.523*	1.523*	1.523*	1.523*	1.467	1.419	1.462	1.428	1.331*
													σ <sub>c</sub>	12.28	8.707	6.845	6.171	4.847	4.368	3.435	3.095	2.192
													σ <sub>c</sub>	8.736	6.191	4.867	4.387	3.476	3.153	2.465	2.232	1.600

Effect of Test Temperature

32	Sintered												β	3.390*	3.546*	3.544*	3.544*	3.544	3.544	3.544	3.544	3.544	3.544*
													θ	18.64	15.28	13.30	12.52	10.90	10.26	8.932	8.413	6.894	
33	Mechanical Polish 8 RMS												α <sub>c</sub>	12.79	10.32	8.989	8.466	7.366	6.938	6.036	5.685	4.659	
													β	.7099*	.9066*	1.075*	1.157*	1.373	1.478	1.753*	1.887*	2.410*	
													θ	17.77	13.91	11.73	10.89	9.187	8.535	7.194	6.684	5.234	
34													α <sub>c</sub>	2.061*	2.061	2.061	2.061	2.061	2.061	2.061	2.061	2.061*	
													θ	12.24	8.768	6.941	6.276	4.968	4.492	3.556	3.215	2.301	
													σ <sub>c</sub>	8.568	6.133	4.855	4.390	3.475	3.142	2.487	2.249	1.610	
35													β	1.523*	1.523*	1.523*	1.523*	1.467	1.419	1.462	1.428	1.331*	
													θ	12.28	8.707	6.845	6.171	4.847	4.368	3.435	3.095	2.192	
													σ <sub>c</sub>	8.736	6.191	4.867	4.387	3.476	3.153	2.465	2.232	1.600	

Su = 68-78 ksi  
 Sy = 60-71 ksi

2014 ALUMINUM

Composition: See Page 16.6  
 (\*) Extrapolated Values

Code No.	TEST CONDITIONS				Other	DIST.	PARAM.	FATIGUE STRENGTH DISTRIBUTIONS AND THEIR PARAMETERS								
	Heat Treat	Surf. Fin.	Freq.	Temp.				R <sub>r</sub>	LIFE IN CYCLES							
								1x10 <sup>3</sup>	1x10 <sup>4</sup>	5x10 <sup>4</sup>	1x10 <sup>5</sup>	5x10 <sup>5</sup>	1x10 <sup>6</sup>	5x10 <sup>6</sup>	1x10 <sup>7</sup>	1x10 <sup>8</sup>

ROTARY BEAM BENDING  
 Miscellaneous

36	T-6 H-Roll Wrought							1.921*	1.781	1.682	1.636	1.770	1.522	1.642	1.689	1.824*
			80	1.0		S.E.V. Wetbull		75.93	63.92	56.68	53.81	47.75	45.31	40.20	38.18	32.17
								68.38	57.85	51.46	48.94	43.23	41.34	36.55	34.66	29.07
37	T-6 H-Roll	M.P.	80	1.0		S.E.V.			.1986*	.2648	.2997	.3996	.4523	.6030	.6825*	1.030*
									67.72	50.79	44.88	33.66	29.74	22.30	19.70	13.06

PLATE BENDING (Completely Reversed)  
 Effect of Heat Treatment

38	T-4		1000	1.0		L.E.V.			.2193	.2808	.3123	.3999	.4448	.5695	.6334	.9020
									59.51	46.48	41.79	32.64	29.35	22.92	20.61	14.47
39	T-6		1000	1.0		Wetbull			1.090*	1.422*	1.422	.8265	.7622	1.054	1.097	1.201*
									58.99	47.21	42.70	33.22	30.02	23.95	21.70	15.60
									47.46	36.24	32.78	27.43	24.87	19.36	17.44	12.37

Composition: See Page 166  
 (\*) Extrapolated Values

2014 ALUMINUM (Cont'd)

S<sub>u</sub> = 68-78 ksi  
 S<sub>y</sub> = 60-71 ksi

Code No.	TEST CONDITIONS				FATIGUE STRENGTH DISTRIBUTIONS AND THEIR PARAMETERS												
	Heat Treat	Surf. Fin.	Freq.	Temp.	K <sub>t</sub>	Other	DIST.	PARAM.	LIFE IN CYCLES								
									1x10 <sup>3</sup>	1x10 <sup>4</sup>	5x10 <sup>4</sup>	1x10 <sup>5</sup>	5x10 <sup>5</sup>	1x10 <sup>6</sup>	5x10 <sup>6</sup>	1x10 <sup>7</sup>	1x10 <sup>8</sup>

PLATE BENDING (Completely Reversed)  
 Effect of Frequency

Code No.	Heat Treat	Surf. Fin.	Freq.	Temp.	K <sub>t</sub>	Other	DIST.	PARAM.	1x10 <sup>3</sup>	1x10 <sup>4</sup>	5x10 <sup>4</sup>	1x10 <sup>5</sup>	5x10 <sup>5</sup>	1x10 <sup>6</sup>	5x10 <sup>6</sup>	1x10 <sup>7</sup>	1x10 <sup>8</sup>
40	T-4		1000	80	1.0			M	.2193 59.51	.2808 46.48	.3123 41.79	.3999 32.64	.4448 29.35	.5695 22.92	.6334 20.61	.9020 14.47	
41	T-4		300	80	1.0			θ X <sub>p</sub>	1.828* .9438 50.05 43.39	1.113 40.13 34.56	1.211 36.51 31.26	1.010 29.20 25.27	1.088 26.56 22.90	1.180 21.30 18.27	1.156 19.35 16.63	1.180* 14.10 12.09	
42	T-6		1000	80	1.0			θ X <sub>p</sub>	1.090* 58.99 47.46	1.422* 47.21 36.24	1.422 42.70 32.78	.8265 33.22 27.43	.7622 30.02 24.87	1.054 23.95 19.36	1.097 21.70 17.44	1.201* 15.60 12.37	
43	T-6		100	80	1.0			θ X <sub>p</sub>	1.835* 57.47 49.11	1.991* 41.22 34.91	1.991 29.54 25.02	1.827 23.39 19.99	1.991 21.17 17.93	1.991 16.77 14.21	1.991 15.17 12.85	1.991* 10.88 9.214	

Effect of Stress Concentration

Code No.	Heat Treat	Surf. Fin.	Freq.	Temp.	K <sub>t</sub>	Other	DIST.	PARAM.	1x10 <sup>3</sup>	1x10 <sup>4</sup>	5x10 <sup>4</sup>	1x10 <sup>5</sup>	5x10 <sup>5</sup>	1x10 <sup>6</sup>	5x10 <sup>6</sup>	1x10 <sup>7</sup>	1x10 <sup>8</sup>
44	T-6			80	1.0			θ X <sub>p</sub>	1.392* 66.86 61.26	1.380 53.56 49.10	1.300 48.65 44.77	1.169 38.93 36.03	1.355 35.45 32.54	1.204 28.36 26.21	1.366 25.82 23.68	1.440 18.81 17.20	
45	T-6			80	1.0			θ X <sub>p</sub>	6.375 45.55	3.639 26.00	3.295 23.54	2.616 18.69	2.369 16.92	1.881 13.44	1.703 12.17	1.224 8.750	

Composition: See Page 166  
 (\*) Extrapolated Values

2014 ALUMINUM (Cont'd)

S<sub>u</sub> = 68-78 ksi  
 S<sub>y</sub> = 60-71 ksi

Code No.	TEST CONDITIONS				FATIGUE STRENGTH DISTRIBUTIONS AND THEIR PARAMETERS							
	Heat Treat	Surt. Fin.	Temp	Other	1x10 <sup>3</sup>	1x10 <sup>4</sup>	5x10 <sup>4</sup>	1x10 <sup>5</sup>	5x10 <sup>5</sup>	1x10 <sup>6</sup>	5x10 <sup>6</sup>	1x10 <sup>7</sup>

PLATE BENDING (Completely Reversed)  
 Effect of Stress Concentration

Code No.	Heat Treat	Surt. Fin.	Temp	Other	DIST.	LIFE IN CYCLES								
						1x10 <sup>3</sup>	1x10 <sup>4</sup>	5x10 <sup>4</sup>	1x10 <sup>5</sup>	5x10 <sup>5</sup>	1x10 <sup>6</sup>	5x10 <sup>6</sup>	1x10 <sup>7</sup>	1x10 <sup>8</sup>
46	T-6		80	1.0	Dist. Wetbull	4.211*	4.113	4.057	4.035	3.992	3.975	3.941	3.927	3.775*
						63.80	49.93	42.07	39.08	32.93	30.59	25.77	23.94	18.73
47	T-6		80	Notched	Dist. Wetbull	5.473	5.619	6.015	5.779	5.781	5.719	5.595	5.927	5.473
						42.25	30.75	24.62	22.38	17.92	16.28	13.04	11.85	8.626
48	T-6		80	1.0	Dist. Wetbull	1.101*	1.129	1.424	1.681	1.521	1.529	1.400*	1.348*	1.222*
						63.97	48.68	40.27	37.14	30.66	28.24	23.31	21.46	16.31
49	T-6		80	1.6	Normal Wetbull	1.990*	1.559*	1.315	1.222	1.030	.9578	.8078*	.7506*	.5883*
						49.76	38.99	32.88	30.56	25.77	23.95	20.19	18.77	14.71
50	T-6		80	2.4	S.E.V.	.5842*	.7635*	.9206	.9979	1.203	1.304	1.572	1.704	2.227*
						38.32	29.32	24.31	22.43	18.60	17.16	14.23	13.13	10.04
51	T-6		80	3.4	Wetbull	1.796*	1.796*	1.796	1.796	1.796	1.796	1.796	1.796	1.796*
						37.80	26.51	20.69	18.59	14.51	13.04	10.18	9.151	6.419
	T-6		80	3.4	Wetbull	27.95	19.60	15.30	13.75	10.73	9.647	7.529	6.767	4.746

S<sub>u</sub> = 68-78 ksi  
 S<sub>y</sub> = 60-71 ksi

2014 ALUMINUM (Cont'd)

Composition: See Page 166  
 (\*) Extrapolated Values

Heat Treat	Surt. Fin.	Temp. Req.	K <sub>t</sub>	TEST CONDITIONS		FATIGUE STRENGTH DISTRIBUTIONS AND THEIR PARAMETERS								
				Other	DIST.	PARAM.	LIFE IN CYCLES							
							1x10 <sup>3</sup>	1x10 <sup>4</sup>	5x10 <sup>4</sup>	1x10 <sup>5</sup>	5x10 <sup>5</sup>	1x10 <sup>6</sup>	5x10 <sup>6</sup>	1x10 <sup>7</sup>

PLATE BENDING (Completely Reversed)  
 Effect of Stress Concentration

Code No.	Heat Treat	Surt. Fin.	Temp. Req.	K <sub>t</sub>	Hot Rolled		S.E.V. Weibull		S.E.V. Weibull		S.E.V. Weibull		S.E.V. Weibull		S.E.V. Weibull	
					Longitudinal	Trans.	σ <sub>q</sub>	b	σ <sub>q</sub>	b	σ <sub>q</sub>	b	σ <sub>q</sub>	b	σ <sub>q</sub>	b
52	T-6	Mechanical Polish	60	80	1.0	60	80	1.0	60	80	1.0	60	80	1.0	60	80
			60	80	1.0	60	80	1.0	60	80	1.0	60	80	1.0	60	80
			80	80	1.0	60	80	1.0	60	80	1.0	60	80	1.0	60	80
			80	80	1.0	60	80	1.0	60	80	1.0	60	80	1.0	60	80

Effect of Grain Direction

Code No.	Heat Treat	Surt. Fin.	Temp. Req.	K <sub>t</sub>	Hot Rolled		S.E.V. Weibull		S.E.V. Weibull		S.E.V. Weibull		S.E.V. Weibull		S.E.V. Weibull	
					Longitudinal	Trans.	σ <sub>q</sub>	b	σ <sub>q</sub>	b	σ <sub>q</sub>	b	σ <sub>q</sub>	b	σ <sub>q</sub>	b
55	T-6	Mechanical Polish	60	80	1.0	60	80	1.0	60	80	1.0	60	80	1.0	60	80
			60	80	1.0	60	80	1.0	60	80	1.0	60	80	1.0	60	80
			80	80	1.0	60	80	1.0	60	80	1.0	60	80	1.0	60	80
			80	80	1.0	60	80	1.0	60	80	1.0	60	80	1.0	60	80

S<sub>y</sub> = 68-73 ksi  
 S<sub>u</sub> = 60-71 ksi

Composition: See Page 166  
 (\*) Extrapolated Values

2014 ALUMINUM (Cont'd)

Code No.	TEST CONDITIONS			FATIGUE STRENGTH DISTRIBUTIONS AND THEIR PARAMETERS													
	Heat Treat	Surf. Fin.	Freq.	Temp	K <sub>t</sub>	Other	DIST.	Param.	LIFE IN CYCLES								
									1x10 <sup>3</sup>	1x10 <sup>4</sup>	5x10 <sup>4</sup>	1x10 <sup>5</sup>	5x10 <sup>5</sup>	1x10 <sup>6</sup>	5x10 <sup>6</sup>	1x10 <sup>7</sup>	1x10 <sup>8</sup>

PLATE BENDING (Completely Reversed)  
 Effect of Grain Size

57	T-6			80	Notched	Long-Longitudinal	Normal	σ <sub>x</sub>	6.375	4.584	3.639	3.295	2.616	2.369	1.881	1.703	1.224
					Notched	Trans. Longitudinal	Normal	σ <sub>y</sub>	45.55	32.74	26.00	23.54	18.69	16.92	13.44	12.17	8.750
58	T-6			80	Notched	Long-Longitudinal	Normal	σ <sub>x</sub>	5.473	5.619	6.015	5.779	5.781	5.719	5.595	5.927	5.473
					Notched	Trans. Longitudinal	Normal	σ <sub>y</sub>	42.25	30.75	24.62	22.38	17.92	16.28	13.04	11.85	8.626
					Notched	Long-Longitudinal	Normal	σ <sub>x</sub>	31.52	22.76	17.83	16.42	13.14	11.99	9.667	8.627	6.435

Effect of Manufacturing Processes

59	T-6	Ground 10 RMS		80	1.0	As Is	Wetbulb	σ <sub>x</sub>	.6891	.7568	.6891	.6891	.6891*	.6891*	.6135*	.6891*	1.314*
							Wetbulb	σ <sub>y</sub>	62.08	47.48	39.21	36.15	29.92	27.58	22.80	21.05	16.38
							Wetbulb	σ <sub>x</sub>	58.30	44.41	36.82	33.95	28.10	25.90	21.46	19.76	14.60
60	T-6	Ground 10 RMS	60	80	1.0	Extruded	Wetbulb	σ <sub>x</sub>	1.269*	1.385*	.9769*	.8802*	1.084	1.094	.9773	.9271	1.250*
							Wetbulb	σ <sub>y</sub>	63.27	50.75	43.32	40.50	34.75	32.52	27.83	26.02	20.91
							Wetbulb	σ <sub>x</sub>	57.39	45.75	39.86	37.40	31.82	29.76	25.60	23.99	18.99
61	T-6	Ground 10 RMS	60	80	1.0	Cold Drawn	Wetbulb	σ <sub>x</sub>	1.101*	1.129	1.424	1.681	1.521	1.529	1.400*	1.348*	1.222*
							Wetbulb	σ <sub>y</sub>	63.97	48.68	40.27	37.14	30.66	28.24	23.31	21.46	16.31
							Wetbulb	σ <sub>x</sub>	59.27	45.06	36.86	33.61	27.94	25.72	21.35	19.70	15.05

Composition: See Page 166  
 (\*) Extrapolated Values

2014 ALUMINUM (Cont'd)

$S_u = 64-67$  ksi

Code No.	TEST CONDITIONS				FATIGUE STRENGTH DISTRIBUTIONS AND THEIR PARAMETERS											
	Heat Treat	Surt. Fin.	Freq.	Temp	$K_t$	Other	DISTR.	Param.	LIFE IN CYCLES							
									$1 \times 10^3$	$1 \times 10^4$	$5 \times 10^4$	$1 \times 10^5$	$5 \times 10^5$	$1 \times 10^6$	$5 \times 10^6$	$1 \times 10^7$

PLATE BENDING (Completely Reversed)  
 Effect of Manufacturing Processes

Code No.	Heat Treat	Surt. Fin.	Freq.	Temp	$K_t$	Other	DISTR.	Param.	$1 \times 10^3$	$1 \times 10^4$	$5 \times 10^4$	$1 \times 10^5$	$5 \times 10^5$	$1 \times 10^6$	$5 \times 10^6$	$1 \times 10^7$	$1 \times 10^8$
62	T-6	M.P.	60	80	1.0	Forged	Wetbull	$\sigma_x \sigma_y$	2.105*	2.108*	2.105	2.105	2.105	2.133	2.105	2.105	2.105*
						Hot Rolled	L.E.V.	$\sigma_x \sigma_y$	50.51	42.62	37.86	35.97	31.95	30.36	26.96	25.62	21.62
									37.11	31.31	27.82	26.43	23.47	22.25	19.81	18.82	15.89
63	T-6	M.P.	60	80	1.0	Hot Rolled	L.E.V.	$\sigma_x \sigma_y$	.1045*	.1632	.2229	.2549	.3480	.3980	.5435*	.6216*	.9706*
									65.37	41.86	30.66	26.81	19.63	17.17	12.57	10.99	7.041

$S_u = 57$  ksi  
 $S_y = 41$  ksi

2014 ALCLAD ALUMINUM

Composition: See Page 166  
 (\*) Extrapolated Values

PLATE BENDING (Completely Reversed)  
 Effect of Heat Treatment

Code No.	Heat Treat	Surt. Fin.	Freq.	Temp	$K_t$	Other	DISTR.	Param.	$1 \times 10^3$	$1 \times 10^4$	$5 \times 10^4$	$1 \times 10^5$	$5 \times 10^5$	$1 \times 10^6$	$5 \times 10^6$	$1 \times 10^7$	$1 \times 10^8$
64	T-4		1000	80	1.0		Wetbull	$\sigma_x \sigma_y$	2.226*	48.44	37.75	33.90	26.43	23.73	18.49	16.61	11.63
									37.04	28.86	25.92	20.09	18.16	14.06	12.68	8.816	2.318*
65	T-5		1000	80	1.0		Wetbull	$\sigma_x \sigma_y$	1.758*	1.828*	1.738*	1.791	1.724	1.842	1.800	1.727	1.727
									53.54	39.76	34.96	25.96	22.83	16.96	14.91	9.739	11.63
									43.19	31.90	28.25	20.89	18.46	13.59	11.99	7.875	8.816



Composition: See Page 166  
 (\*) Extrapolated Values

2014 ALCLAD ALUMINUM (Cont'd)

$\sigma_u = 64-67$  ksi

Code No.	TEST CONDITIONS				FATIGUE STRENGTH DISTRIBUTIONS AND THEIR PARAMETERS													
	Heat Treat	Surf. Fin.	Freq.	Temp °F	$K_t$	Other	DISTR.	Param.	LIFE IN CYCLES									
									$1 \times 10^3$	$1 \times 10^4$	$5 \times 10^4$	$1 \times 10^5$	$5 \times 10^5$	$1 \times 10^6$	$5 \times 10^6$	$1 \times 10^7$	$1 \times 10^8$	

PLATE BENDING (Completely Reversed)  
 Effect of Frequency

66	T-4		1000	80	1.0				2.226*	48.44	37.04	2.226*	33.90	26.43	2.218	18.49	2.241	11.63	2.318*	8.816
67	T-4		32	80	1.0			4.827*	3.391*	30.31	2.650*	2.383	21.29	16.64	1.674	11.69	1.308	7.388	.8266*	
68	T-6		1000	80	1.0				1.758*	53.54	39.76	1.828*	34.96	25.96	1.724	16.96	1.800	9.739	7.875	
69	T-6		10	80	1.0				1.962*	27.26	19.47	1.956	16.83	12.02	2.134	7.424	1.990	3.964	3.093	

Miscellaneous

70	T-6			80	Ho-N				1.891	48.36	30.74	1.881	22.40	14.24	1.855	9.055	1.893*	7.900	5.022	2.870
									27.64	17.58	12.83	11.27	8.166	7.156	5.158	4.514				

S<sub>u</sub> = 82 ksi  
S<sub>y</sub> = 77 ksi

R-303 ALUMINUM

Composition: See Page 166  
(\* Extrapolated Values)

Code No.	TEST CONDITIONS			FATIGUE STRENGTH DISTRIBUTIONS AND THEIR PARAMETERS												
	Heat Treat	Surf. Fin.	Req. Temp.	K <sub>t</sub>	Other	DISP.	Param.	LIFE IN CYCLES								
								1x10 <sup>3</sup>	1x10 <sup>4</sup>	5x10 <sup>4</sup>	1x10 <sup>5</sup>	5x10 <sup>5</sup>	1x10 <sup>6</sup>	5x10 <sup>6</sup>	1x10 <sup>7</sup>	1x10 <sup>8</sup>

ROTARY BEAM BENDING

Code No.	Heat Treat	Surf. Fin.	Req. Temp.	K <sub>t</sub>	Other	DISP.	Param.	LIFE IN CYCLES									
								1x10 <sup>3</sup>	1x10 <sup>4</sup>	5x10 <sup>4</sup>	1x10 <sup>5</sup>	5x10 <sup>5</sup>	1x10 <sup>6</sup>	5x10 <sup>6</sup>	1x10 <sup>7</sup>	1x10 <sup>8</sup>	
71		LIB	177	80	1.0	Cast	S.E.V.	B	M	.1743*	.2219*	.2463*	.3136	.3480	.4431	.4918	.6949*

PLATE BENDING (Completely Reversed)

Code No.	Heat Treat	Surf. Fin.	Req. Temp.	K <sub>t</sub>	Other	DISP.	Param.	LIFE IN CYCLES										
								1x10 <sup>3</sup>	1x10 <sup>4</sup>	5x10 <sup>4</sup>	1x10 <sup>5</sup>	5x10 <sup>5</sup>	1x10 <sup>6</sup>	5x10 <sup>6</sup>	1x10 <sup>7</sup>	1x10 <sup>8</sup>		
72		Ground	29.2	80	1.0	Extru- ston	Weibull	p	q	3.749*	3.493*	4.143*	4.061	3.891	4.255	4.334	4.067	4.346*
										50.37	33.80	31.71	27.30	25.11	21.39	20.23	15.96	

S<sub>u</sub> = 83 ksi  
S<sub>y</sub> = 79 ksi

2020 ALUMINUM

Composition: See Page 166  
(\* Extrapolated Values)

AXIAL (Completely Reversed)

Code No.	Heat Treat	Surf. Fin.	Req. Temp.	K <sub>t</sub>	Other	DISP.	Param.	LIFE IN CYCLES									
								1x10 <sup>3</sup>	1x10 <sup>4</sup>	5x10 <sup>4</sup>	1x10 <sup>5</sup>	5x10 <sup>5</sup>	1x10 <sup>6</sup>	5x10 <sup>6</sup>	1x10 <sup>7</sup>	1x10 <sup>8</sup>	
73	1-6	M.P.		80	1.0	Hot Rolled	S.E.V.	B	M	.2221	.2870	.3205	.4141	.4624	.5974*	.6671*	.9624*

Composition: See Page 166  
 (\*) Extrapolated Values

2024 ALUMINUM  
 (SHEET OR PLATES)

S<sub>y</sub> = 61-81 ksi  
 S<sub>u</sub> = 45-61 ksi

Code No.	TEST CONDITIONS		FATIGUE STRENGTH DISTRIBUTIONS AND THEIR PARAMETERS													
	Heat Treat	Surf. Fin.	Temp. °F	r	Other	DIST.	Form	LIFE IN CYCLES								
								1x10 <sup>3</sup>	1x10 <sup>4</sup>	5x10 <sup>4</sup>	1x10 <sup>5</sup>	5x10 <sup>5</sup>	1x10 <sup>6</sup>	5x10 <sup>6</sup>	1x10 <sup>7</sup>	1x10 <sup>8</sup>

AXIAL (Completely Reversed)  
 Effect of Specimen Configuration

74																	
75																	
76																	
77																	
78																	
79																	

SP-1 - Sheet - .125 in. or less, unnotched  
 SP-2 - Sheet - .125 in. or less, Symmetrical Edge Notch, Flank Angle (0) Degree  
 SP-3 - Sheet - .125 in. hick or less. hole notch

2024 ALUMINUM (Cont'd)  
(SHEET OR PLATES)

Composition: See Page 166  
(\* Extrapolated Values)

S<sub>y</sub> = 61-81 ksi  
S<sub>u</sub> = 45-61 ksi

Code No.	TEST CONDITIONS				FATIGUE STRENGTH DISTRIBUTIONS AND THEIR PARAMETERS												
	Heat Treat	Surt. Fin.	Freq.	Temp.	R <sub>r</sub>	Other	DIST.	Param.	LIFE IN CYCLES								
									1x10 <sup>3</sup>	1x10 <sup>4</sup>	5x10 <sup>4</sup>	1x10 <sup>5</sup>	5x10 <sup>5</sup>	1x10 <sup>6</sup>	5x10 <sup>6</sup>	1x10 <sup>7</sup>	1x10 <sup>8</sup>

AXIAL (Completely Reversed)  
Effect of Specimen Configuration

Code No.	Heat Treat	Surt. Fin.	Freq.	Temp.	R <sub>r</sub>	Other	DIST.	Param.	2.735*	2.681	2.681	2.681	2.681	2.681	2.681	2.681	2.681*
80	I-3	Milled Edges Electropolished	25	80	4.0	SP-4	Normal Weibull	σ <sub>0</sub>	25.17	17.59	13.69	12.29	9.572	8.593	6.690	6.006	4.197
81	I-3		25	80	4.0	SP-7	Normal Weibull	σ <sub>0</sub>	31.46	20.94	15.76	13.94	10.49	9.282	6.984	6.179	4.113

Effect of Frequency

Code No.	Heat Treat	Surt. Fin.	Freq.	Temp.	R <sub>r</sub>	Other	DIST.	Param.	1.767*	1.784*	1.898	1.844	1.767	1.767	1.767	1.871	1.841	1.767*
82	I-3		24	80	2.9	SP-3	Weibull	σ <sub>0</sub>	33.12	24.77	20.23	18.53	15.12	13.85	11.31	10.36	10.36	7.751
83	I-3		37	80	2.9	SP-3	Weibull	σ <sub>0</sub>	27.35	20.43	16.55	15.22	12.49	11.44	9.276	8.517	8.517	6.402
84	I-3	Electropolished	24	80	2.8	SP-3	Weibull	σ <sub>0</sub>	31.61	23.49	19.11	17.48	14.21	13.00	10.57	9.674	9.674	7.190
85	I-3		37	80	2.8	SP-3	Normal Weibull	σ <sub>0</sub>	4.820*	3.707	3.086	2.851	2.373	2.193	1.825	1.687	1.687	1.297*

SP-4 - Sheet - .125 in. thick or less, Symmetrical Edge Notch, Flank Angle 0 Degree Grain direction parallel to lengthwise axis

Composition: See Page 166  
 (\*) Extrapolated Values

2024 ALUMINUM (Cont'd)  
 (SHEET OR PLATES)

S<sub>y</sub> = 61-81 ksi  
 S<sub>u</sub> = 45-61 ksi

Code No.	TEST CONDITIONS				FATIGUE STRENGTH DISTRIBUTIONS AND THEIR PARAMETERS												
	Heat Treat	Surf. Fin.	Freq.	Temp	R <sub>r</sub>	Other	DIST.	Form	LIFE IN CYCLES								
									1x10 <sup>3</sup>	1x10 <sup>4</sup>	5x10 <sup>4</sup>	1x10 <sup>5</sup>	5x10 <sup>5</sup>	1x10 <sup>6</sup>	5x10 <sup>6</sup>	1x10 <sup>7</sup>	1x10 <sup>8</sup>

AXIAL (Completely Reversed)  
 Effect of Frequency

Code No.	Heat Treat	Surf. Fin.	Freq.	Temp	R <sub>r</sub>	Other	DIST.	Form	1x10 <sup>3</sup>	1x10 <sup>4</sup>	5x10 <sup>4</sup>	1x10 <sup>5</sup>	5x10 <sup>5</sup>	1x10 <sup>6</sup>	5x10 <sup>6</sup>	1x10 <sup>7</sup>	1x10 <sup>8</sup>
86	T-3	Electropolished	6	80	2.6	SP-3	Normal	Normal	3.141*	2.318	1.875	1.711	1.384	1.263	1.021	.9326	.6885*
									30.35	22.40	18.12	16.53	13.37	12.20	9.874	9.012	6.652
87	T-3	Electropolished	37	80	2.6	SP-3	Wetbull	Wetbull	1.781*	1.862	1.775	1.977	1.916	1.893	1.863	1.863	1.863
									35.07	26.37	21.59	19.83	16.24	14.90	12.20	11.20	8.423
									27.76	20.74	17.10	15.45	12.72	11.69	9.604	8.813	6.625
88	T-3	Electropolished	6	80	2.4	SP-3	Wetbull	Wetbull	3.549*	3.560	3.463	3.426	3.539	3.511	3.455	3.433	3.374*
									30.77	23.42	19.35	17.82	14.73	13.57	11.21	10.33	7.863
									20.08	15.27	12.75	11.79	9.630	8.897	7.396	6.828	5.230
89	T-3	Electropolished	24-30	80	2.4	SP-3	Wetbull	Wetbull	1.984*	1.767	1.980	1.936	1.844	1.808	1.734	1.719	1.719*
									36.25	27.76	23.07	21.29	17.67	16.31	13.54	12.49	9.579
									30.29	23.48	19.28	17.84	14.88	13.76	11.47	10.59	8.123
90	T-3	Electropolished	6	80	2.2	SP-3	Wetbull	Wetbull	3.591*	3.640*	3.547	3.512	3.441	3.628	3.574	3.553	3.512*
									31.83	24.55	20.46	18.92	15.78	14.59	12.17	11.25	8.680
									21.87	16.78	14.12	13.10	10.99	9.994	8.377	7.761	6.007
91	T-3	Electropolished	24-30	80	2.2	SP-3	Normal	Normal	3.561*	2.924*	2.547	2.401	2.092	1.971	1.717	1.618	1.329*
									27.98	22.97	20.01	18.86	16.43	15.49	13.49	12.71	10.44

SP-5 Sheet-.125 in. thick or less, Hole Notch, grain direction parallel to lengthwise axis  
 SP-6 Sheet-.125 in. thick or less, Unnotched, Constant stress test length

Composition: See Page 166  
 (\*) Extrapolated Values

2024 ALUMINUM (Cont'd)  
 (SHEET OR PLATES)

S<sub>x</sub> = 61-81 ksi  
 S<sub>y</sub> = 45-61 ksi

Code No.	TEST CONDITIONS				FATIGUE STRENGTH DISTRIBUTIONS AND THEIR PARAMETERS										
	Heat Treat	Surt. Fin.	Temp. °F	R <sub>r</sub>	Other	DIST. Param.	LIFE IN CYCLES								
							1x10 <sup>3</sup>	1x10 <sup>4</sup>	5x10 <sup>4</sup>	1x10 <sup>5</sup>	5x10 <sup>5</sup>	1x10 <sup>6</sup>	5x10 <sup>6</sup>	1x10 <sup>7</sup>	1x10 <sup>8</sup>

AXIAL (Completely Reversed)  
 Effect of Stress Concentration

Code No.	Heat Treat	Surt. Fin.	Temp. °F	R <sub>r</sub>	Other	DIST. Param.	1x10 <sup>3</sup>	1x10 <sup>4</sup>	5x10 <sup>4</sup>	1x10 <sup>5</sup>	5x10 <sup>5</sup>	1x10 <sup>6</sup>	5x10 <sup>6</sup>	1x10 <sup>7</sup>	1x10 <sup>8</sup>
92	I-3		24	2.9	SP-3	Wetbull	1.767*	1.784*	1.898	1.844	1.767	1.767	1.871	1.841	1.767*
							33.12	24.77	20.23	18.53	15.12	13.85	11.31	10.36	7.751
							27.35	20.43	16.55	15.22	12.49	11.44	9.276	8.517	6.402
93	I-3		80	2.8	SP-3	Wetbull	1.616*	1.459	1.540	1.609	1.592	1.527	1.706	1.660	1.531*
							31.61	23.49	19.11	17.48	14.21	13.00	10.57	9.674	7.190
							26.67	20.00	16.19	14.75	12.01	11.02	8.874	8.139	6.097
94	I-3		80	2.6	SP-3	Normal	3.141*	2.318	1.875	1.711	1.384	1.263	1.021	.9326	.6885*
							30.35	22.40	18.12	16.53	13.37	12.20	9.874	9.012	6.652
95	I-3		80	2.4	SP-3	Wetbull	3.549*	3.560	3.463	3.426	3.539	3.511	3.455	3.433	3.374*
							30.77	23.42	19.35	17.82	14.73	13.57	11.21	10.33	7.863
							20.08	15.27	12.75	11.79	9.630	8.897	7.396	6.828	5.230
96	I-3		80	2.2	SP-3	Wetbull	3.591*	3.640*	3.547	3.512	3.441	3.628	3.574	3.553	3.512*
							31.83	24.55	20.46	18.92	15.78	14.59	12.17	11.25	8.680
							21.87	16.78	14.12	13.10	10.99	9.994	8.377	7.761	6.007
97	I-3		37	2.9	SP-3	Wetbull	6.692*	6.604*	6.352	6.119	5.703	5.566	5.386	5.340	5.213*
							34.92	26.11	21.31	19.52	15.93	14.60	11.91	10.91	8.164
							19.54	14.74	12.33	11.54	9.790	9.079	7.527	6.924	5.233

SP-7: Sheet - .125 in. thick or less, Fillet notch, grain direction parallel to lengthwise axis

SP-8: Plate - over .125 in. thick, Unnotched

S<sub>u</sub> = 61-81 ksi  
 S<sub>y</sub> = 45-61 ksi

2024 ALUMINUM (Cont'd)  
 (SHEET OR PLATES)

Composition: See Page 166  
 (\*) Extrapolated Values

Code No.	TEST CONDITIONS				FATIGUE STRENGTH DISTRIBUTIONS AND THEIR PARAMETERS												
	Heat Treat	Surf. Fin.	Freq.	Temp	R <sub>r</sub>	Other	DISTR.	LIFE IN CYCLES									
								1x10 <sup>3</sup>	1x10 <sup>4</sup>	5x10 <sup>4</sup>	1x10 <sup>5</sup>	5x10 <sup>5</sup>	1x10 <sup>6</sup>	5x10 <sup>6</sup>	1x10 <sup>7</sup>	1x10 <sup>8</sup>	

AXIAL (Completely Reversed)  
 Effect of Stress Concentration

Code No.	Heat Treat	Surf. Fin.	Freq.	Temp	R <sub>r</sub>	Other	DISTR.	σ <sub>u</sub>	σ <sub>0.2</sub>	σ <sub>0.05</sub>	σ <sub>0.01</sub>	σ <sub>0.005</sub>	σ <sub>0.001</sub>	σ <sub>0.0005</sub>	σ <sub>0.0001</sub>	σ <sub>0.00005</sub>	σ <sub>0.00001</sub>
98	T-3	Electropolished	24-30	80	2.8	SP-3	Normal	4.820*	3.707	3.086	2.851	2.373	2.193	1.825	1.687	1.297*	8.583
99	T-3	Electropolished	37	80	2.6	SP-3	Normal	1.781*	1.862	1.775	1.977	1.916	1.893	1.863	1.863	1.863*	8.423
100	T-3	Electropolished	24-30	80	2.4	SP-3	Normal	1.984*	1.767	1.980	1.936	1.844	1.808	1.734	1.719	1.719*	8.123
101	T-3	Electropolished	24-30	80	2.2	SP-3	Normal	3.561*	2.924*	2.547	2.401	2.092	1.971	1.717	1.618	1.329*	10.44
102	T-3	Milled Edges Electropolished	25	80	1.5	SP-6	S.F.V.	.3392*	.4580	.5649	.6183	.7627	.8348	1.029*	1.127*	1.521*	10.96
103	T-3	Milled Edges Electropolished	25	80	2.0	SP-6	Normal	1.623*	1.907	1.789	1.807	1.872	1.785*	1.908*	1.852*	1.722*	4.388

S<sub>u</sub> = 61-81 ksi  
 S<sub>y</sub> = 45-61 ksi

2024 ALUMINUM (Cont'd)  
 (SHEET OR PLATES)

Composition: See Page 166  
 (\*) Extrapolated Values

Code No.	TEST CONDITIONS				FATIGUE STRENGTH DISTRIBUTIONS AND THEIR PARAMETERS												
	Heat Treat	Surf. Fin.	Freq.	Temp.	R <sub>r</sub>	Other	DIST.	Param.	LIFE IN CYCLES								
									1x10 <sup>3</sup>	1x10 <sup>4</sup>	5x10 <sup>4</sup>	1x10 <sup>5</sup>	5x10 <sup>5</sup>	1x10 <sup>6</sup>	5x10 <sup>6</sup>	1x10 <sup>7</sup>	1x10 <sup>8</sup>

AXIAL (Completely Reversed)  
 Effect of Stress Concentration

104	T-3	Milled Edges	25	80	4.0	SP-4	Webull	σ <sub>u</sub>	2.735*	2.681	2.681	2.681	2.681	2.681	2.681	2.681	2.681*	2.681*
								σ <sub>0</sub>	25.17	17.59	13.69	12.29	9.572	8.593	6.690	6.006	4.197	4.197
								σ <sub>0</sub>	17.97	12.63	9.835	8.830	6.874	6.171	4.804	4.313	3.014	3.014
105	T-3		25	80	5.0	SP-4	Webull	σ <sub>u</sub>	4.602*	4.413	4.322	4.291	4.237	4.237	4.237*	4.214*	3.986*	3.986*
								σ <sub>0</sub>	28.20	18.10	13.27	11.61	8.521	7.456	5.468	4.785	3.071	3.071
								σ <sub>0</sub>	14.55	9.613	7.143	6.279	4.641	4.061	2.978	2.614	1.732	1.732
106				80	1.0		Webull	σ <sub>u</sub>	1.627*	1.921	1.974	1.921	1.808	1.763*	1.667*	1.661*	1.661*	1.661*
								σ <sub>0</sub>	66.99	49.89	40.60	37.14	30.20	27.63	22.47	20.56	15.30	15.30
								σ <sub>0</sub>	57.28	42.10	34.16	31.33	25.63	23.49	19.19	17.56	13.07	13.07
107				80	Ho-N		Webull	σ <sub>u</sub>	3.491	3.306	3.206	3.168	3.158	3.158	3.158	3.158*	3.158*	3.158*
								σ <sub>0</sub>	40.40	29.74	24.01	21.90	17.68	16.12	13.02	11.87	8.743	8.743
								σ <sub>0</sub>	32.63	24.24	16.66	17.96	14.51	13.23	10.68	9.747	7.177	7.177
108	T-3			80	4.0		S.E.V. Webull	σ <sub>u</sub>	.7311*	1.001	1.248	1.372	1.710	1.880	2.343	2.576	3.530*	3.530*
								σ <sub>0</sub>	25.13	18.34	14.72	13.38	10.74	9.771	7.841	7.131	5.205	5.205
109	T-3			80	1.0		Webull	σ <sub>u</sub>	3.514*	3.701	3.536	3.477	3.637	3.596	3.516*	3.515*	3.515*	3.515*
								σ <sub>0</sub>	75.56	52.58	40.79	36.57	28.38	25.44	19.74	17.70	12.31	12.31
								σ <sub>0</sub>	56.75	38.98	30.59	27.53	21.13	19.00	14.82	13.29	9.249	9.249



S<sub>y</sub> = 61-81 ksi  
S<sub>u</sub> = 45-61 ksi

2024 ALUMINUM (Cont'd)  
(SHEET OR PLATES)

Composition: See Page 166  
(\* Extrapolated Values)

+Code No.	TEST CONDITIONS				FATIGUE STRENGTH DISTRIBUTIONS AND THEIR PARAMETERS												
	Heat Treat	Surf. Fin.	Freq.	Temp °F	R <sub>t</sub>	Other	DIST.	Param.	LIFE IN CYCLES								
									1x10 <sup>3</sup>	1x10 <sup>4</sup>	5x10 <sup>4</sup>	1x10 <sup>5</sup>	5x10 <sup>5</sup>	1x10 <sup>6</sup>	5x10 <sup>6</sup>	1x10 <sup>7</sup>	1x10 <sup>8</sup>

AXIAL (Completely Reversed)  
Effect of Notch Radius

110	T-3			80	4.0	N. Rad. .004 in.	Wetbull	b θ X <sub>o</sub>	2.559* 45.82 31.74	2.548 31.22 21.66	2.546 23.88 16.57	2.476 21.27 14.89	2.502 16.27 11.35	2.454 14.49 10.17	2.524 11.09 7.717	2.491 9.881 6.902	2.568* 6.735 4.661
111	T-3			80	4.0	N. Rad. .07 in.	S.E.V.	β M	.9643* 24.52	1.345 17.58	1.697 13.93	1.876 12.60	2.367 9.989	2.616 9.037	3.301 7.162	3.649* 6.479	5.090* 4.645

PLATE BENDING (Completely Reversed)  
Effect of Stress Concentration

112	T-4	Ground	SP-3	30	7.4	SP-3	Normal	σ <sub>y</sub> θ ρ	4.146* 54.71	2.250 29.70	1.468 19.37	1.221 16.12	.7972 10.52	.6633* 8.753	.4327* 5.711	.3600* 4.751	.1954* 2.579
113	T-4		SP-3	30	80	7.9	SP-3	Wetbull	σ <sub>y</sub> θ ρ	1.043* 72.31 59.60	1.083 35.11 28.75	1.368 21.55 16.52	1.407 17.36 13.18	1.466* 10.50 7.836	1.476* 8.450 6.286	1.476* 5.092 3.788	1.476* 4.094 3.045

Composition: See Page 166  
 (\*) Extrapolated Values

2024 ALUMINUM (Cont'd)  
 (SHEET OR PLATES)

S<sub>u</sub> = 61-81 ksi  
 S<sub>y</sub> = 45-61 ksi

Code No.	TEST CONDITIONS				FATIGUE STRENGTH DISTRIBUTIONS AND THEIR PARAMETERS												
	Heat Treat	Surf. Fin.	Freq.	Temp.	K <sub>t</sub>	Other	DIST.	Param.	LIFE IN CYCLES								
									1x10 <sup>3</sup>	1x10 <sup>4</sup>	5x10 <sup>4</sup>	1x10 <sup>5</sup>	5x10 <sup>5</sup>	1x10 <sup>6</sup>	5x10 <sup>6</sup>	1x10 <sup>7</sup>	1x10 <sup>8</sup>

PLATE BENDING (Completely Reversed)

Miscellaneous

Code No.	Heat Treat	Surf. Fin.	Freq.	Temp.	K <sub>t</sub>	Other	DIST.	Param.	1x10 <sup>3</sup>	1x10 <sup>4</sup>	5x10 <sup>4</sup>	1x10 <sup>5</sup>	5x10 <sup>5</sup>	1x10 <sup>6</sup>	5x10 <sup>6</sup>	1x10 <sup>7</sup>	1x10 <sup>8</sup>
114	T-3	Ground Edges	30	80	1.0	SP-6	Normal S.E.V.	8	.2428* 59.04	.3265 43.91	.3709 38.65	.4987 28.75	.5665 25.31	.7616* 18.82	.8652* 16.57	1.321* 10.85	
115	T-4	M.P.	30	80	1.0	SP-8	Normal	8	3.123* 57.64	2.376* 43.85	2.112* 38.98	1.607 2.66	1.428 26.36	1.087 20.06	.9663 17.83	.6536* 12.06	

S<sub>u</sub> = 61-81 ksi  
 S<sub>y</sub> = 45-61 ksi

2024 ALUMINUM  
 (BARS)

Composition: See Page 166  
 (\*) Extrapolated Values

ROTARY BEAM BENDING

Miscellaneous

Code No.	Heat Treat	Surf. Fin.	Freq.	Temp.	K <sub>t</sub>	Other	DIST.	Param.	1x10 <sup>3</sup>	1x10 <sup>4</sup>	5x10 <sup>4</sup>	1x10 <sup>5</sup>	5x10 <sup>5</sup>	1x10 <sup>6</sup>	5x10 <sup>6</sup>	1x10 <sup>7</sup>	1x10 <sup>8</sup>
116	T-4	M.P.	25	80	1.0	Cold Rolled	Normal	8	3.332* 63.25	3.277* 50.49	3.262 43.14	3.404 40.32	3.279 34.44	3.242 32.18	3.398 27.50	3.368 25.63	3.283* 20.51
117	T-4	Ground	25	80	3.9	Cold Rolled	Normal	8	4.684* 25.46	3.815 20.74	3.306 17.97	3.108 16.89	2.693 14.63	2.532 13.76	2.194 11.92	2.062* 11.21	1.680* 9.133

Composition: See Page 1646  
 (\*) Extrapolated Values

2024 ALUMINUM (Cont'd)  
 (BARS)

S<sub>y</sub> = 61-81 ksi  
 S<sub>u</sub> = 45-61 ksi

Code No.	TEST CONDITIONS				FATIGUE STRENGTH DISTRIBUTIONS AND THEIR PARAMETERS												
	Heat Treat	Surf. Fin.	Freq.	Temp	R <sub>r</sub>	Other	DIST.	Form	LIFE IN CYCLES								
									1x10 <sup>3</sup>	1x10 <sup>4</sup>	5x10 <sup>4</sup>	1x10 <sup>5</sup>	5x10 <sup>5</sup>	1x10 <sup>6</sup>	5x10 <sup>6</sup>	1x10 <sup>7</sup>	1x10 <sup>8</sup>

AXIAL (Completely Reversed)  
 Effect of Stress Concentration

Code No.	Heat Treat	Surf. Fin.	Freq.	Temp	R <sub>r</sub>	Other	DIST.	Form	1x10 <sup>3</sup>	1x10 <sup>4</sup>	5x10 <sup>4</sup>	1x10 <sup>5</sup>	5x10 <sup>5</sup>	1x10 <sup>6</sup>	5x10 <sup>6</sup>	1x10 <sup>7</sup>	1x10 <sup>8</sup>	
118	T-4		60	80	1.0		Normal	σ	3.818*	3.020	2.564	2.389	2.028	1.890	1.604	1.495*	1.183*	
							Webull	σ	62.30	49.28	41.84	38.99	33.10	30.84	26.18	24.40	19.30	
119	T-4		50	80	1.6		Normal	σ	1.729*	1.303*	1.434	1.372	1.717	1.680	1.609*	1.609*	1.609*	1.609*
							Webull	σ	49.61	38.46	32.24	29.87	25.07	23.23	19.46	18.03	14.00	14.00
							Webull	σ	43.98	34.68	28.95	26.88	22.24	20.64	17.35	16.07	12.48	12.48
120	T-4		60	80	2.4		Normal	σ	1.850*	1.850	1.851	1.851	1.851	1.851	1.851	1.851*	1.851*	1.851*
							Webull	σ	42.70	31.77	25.84	23.64	19.23	17.59	14.31	13.09	9.743	9.743
							Webull	σ	34.71	25.83	21.01	19.22	15.63	14.30	11.63	10.64	7.921	7.921
121	T-4		60	80	3.4		Normal	σ	.9193*	.7968	.9826	1.182	.7652	1.083	.8076*	1.148*	.9826*	.9826*
							Webull	σ	48.66	30.99	22.67	19.85	14.43	12.64	9.205	8.070	5.135	5.135
							Webull	σ	43.36	27.75	20.14	17.43	12.93	11.17	8.240	7.101	4.562	4.562
122	T-3		20	80	1.0		S.E.V.	σ	.1486*	.2151	.2787	.3115	.4035	.4510	.5841	.6530	.9453*	.9453*
							S.E.V.	σ	76.31	52.70	40.69	36.40	28.11	25.14	19.41	17.37	11.99	11.99
123	T-3		20	80	2.0		S.E.V.	σ	.2787	.4035	.5227	.5642	.7567	.8458	1.095*	1.224*	1.772*	1.772*
							S.E.V.	σ	41.32	28.54	22.04	19.71	15.22	13.62	10.51	9.408	6.498	6.498

Composition: See Page 166  
 (\*) Extrapolated Values

2024 ALUMINUM (Cont'd)  
 (BARS)

S<sub>u</sub> = 61-81 ksi  
 S<sub>y</sub> = 45-61 ksi

Code No.	TEST CONDITIONS				FATIGUE STRENGTH DISTRIBUTIONS AND THEIR PARAMETERS										
	Heat Treat	Surf. Fin.	Temp. Req.	R <sub>r</sub>	Other	DIST.	LIFE IN CYCLES								
							1x10 <sup>3</sup>	1x10 <sup>4</sup>	5x10 <sup>4</sup>	1x10 <sup>5</sup>	5x10 <sup>5</sup>	1x10 <sup>6</sup>	5x10 <sup>6</sup>	1x10 <sup>7</sup>	1x10 <sup>8</sup>

AXIAL (Completely Reversed)  
 Effect of Stress Concentration (Continued)

Code No.	Heat Treat	Surf. Fin.	Temp. Req.	R <sub>r</sub>	Other	DIST.	LIFE IN CYCLES									
							1x10 <sup>3</sup>	1x10 <sup>4</sup>	5x10 <sup>4</sup>	1x10 <sup>5</sup>	5x10 <sup>5</sup>	1x10 <sup>6</sup>	5x10 <sup>6</sup>	1x10 <sup>7</sup>	1x10 <sup>8</sup>	
124	T-3		20	80	4.0	Webull	b	5.948	5.670	5.547	5.503	5.257	5.159	5.005	4.950*	4.805*
							θ	26.51	18.23	14.03	12.53	9.651	8.622	6.637	5.929	4.077
						px	14.17	10.06	7.854	7.051	5.574	5.031	3.935	3.535	2.467	

S<sub>u</sub> = 61-81 ksi  
 S<sub>y</sub> = 45-61 ksi

2024 ALUMINUM  
 (EXTRUSIONS)

Composition: See Page 166  
 (\*) Extrapolated Values

ROTARY BEAM BENDING  
 Effect of Manufacturing Processes

Code No.	Heat Treat	Surf. Fin.	Temp. Req.	R <sub>r</sub>	Other	DIST.	LIFE IN CYCLES									
							1x10 <sup>3</sup>	1x10 <sup>4</sup>	5x10 <sup>4</sup>	1x10 <sup>5</sup>	5x10 <sup>5</sup>	1x10 <sup>6</sup>	5x10 <sup>6</sup>	1x10 <sup>7</sup>	1x10 <sup>8</sup>	
125	T-4		80	Notched	As Is	Normal	b	7.899*	5.540*	4.324*	3.886*	3.032	2.725	2.127	1.911	1.340*
							θ	66.39	46.57	36.34	32.66	25.49	22.90	17.87	16.06	11.27
126	T-4		80	Notched	Recrys-tallize	Webull	b	2.230*	2.458*	2.458	2.458	2.458	2.458	2.458	2.458*	2.458*
							θ	52.22	37.17	29.30	26.45	20.85	18.81	14.83	13.39	9.527
						px	42.67	29.97	23.62	21.32	16.81	15.17	11.96	10.79	7.682	

2024 ALUMINUM (Cont'd)  
(EXTRUSIONS)

Composition: See Page 166  
(\* Extrapolated Values)

S<sub>u</sub> = 61-81 ksi  
S<sub>y</sub> = 45-61 ksi

Code No.	TEST CONDITIONS				FATIGUE STRENGTH DISTRIBUTIONS AND THEIR PARAMETERS											
	Heat Treat	S <sub>ur</sub>	Fin.	Temp.	R <sub>r</sub>	Other	DISTR.	Param.	LIFE IN CYCLES							
									1x10 <sup>3</sup>	1x10 <sup>4</sup>	5x10 <sup>4</sup>	1x10 <sup>5</sup>	5x10 <sup>5</sup>	1x10 <sup>6</sup>	5x10 <sup>6</sup>	1x10 <sup>7</sup>

ROTARY BEAM BENDING  
Effect of Manufacturing Processes

127	T-4		Long-Transverse		80	Notched	As Is	Wetball	Wetball	M 3	3.311*	3.320*	2.231*	3.377	3.313	3.289	3.242	3.236	3.236*
											51.43	37.23	29.70	26.95	21.50	19.50	15.56	14.11	10.21
											33.97	24.56	19.78	17.67	14.19	12.91	10.35	9.399	6.803
128	T-4				80	Notched	Recrys- talize	Wetball	Wetball	M 3	2.454*	2.450	2.475	2.425	2.491	2.455	2.467	2.524	2.456*
											52.58	37.38	29.44	26.56	20.93	18.88	14.87	13.42	9.543
											35.92	25.54	20.06	18.20	14.23	12.89	10.14	9.098	6.517
129	T-4				80	1.0	Wrought	L.F.V.	L.F.V.	M 3	.1888*	.2221	.2487	.2612	.2925	.3071	.3440	.3612	.4247*
											65.80	55.95	49.96	47.58	42.48	40.46	36.13	34.40	29.26

Effect of Stress Concentration

130	T-4				80	Notched	Longitudinal	Normal	Normal	M 3	7.899*	5.540*	4.324*	3.886*	3.032	2.725	2.127	1.911	1.340*
											66.39	46.57	36.34	32.66	25.49	22.90	17.87	16.06	11.27
131	T-4				80	1.0	Longitudinal	L.F.V.	L.F.V.	M 3			.2141*	.2408*	.3164*	.3559	.4677	.5261	.7775*
												64.96	57.76	43.96	39.08	29.74	26.44	26.44	17.89

Composition: See Page 168  
 (\*) Extrapolated Values

2024 ALUMINUM (Cont'd)  
 (EXTRUSIONS)

S<sub>u</sub> = 61-81 ksi  
 S<sub>y</sub> = 45-61 ksi

Code No.	TEST CONDITIONS				FATIGUE STRENGTH DISTRIBUTIONS AND THEIR PARAMETERS												
	Heat Treat	Surf. Fin.	Freq.	Temp	R <sub>r</sub>	Other	DIST.	Param.	LIFE IN CYCLES								
									1x10 <sup>3</sup>	1x10 <sup>4</sup>	5x10 <sup>4</sup>	1x10 <sup>5</sup>	5x10 <sup>5</sup>	1x10 <sup>6</sup>	5x10 <sup>6</sup>	1x10 <sup>7</sup>	1x10 <sup>8</sup>

ROTARY BEAM BENDING  
 Effect of Surface Finish

Code No.	Heat Treat	Surf. Fin.	Freq.	Temp	R <sub>r</sub>	Other	DIST.	Param.	1x10 <sup>3</sup>	1x10 <sup>4</sup>	5x10 <sup>4</sup>	1x10 <sup>5</sup>	5x10 <sup>5</sup>	1x10 <sup>6</sup>	5x10 <sup>6</sup>	1x10 <sup>7</sup>	1x10 <sup>8</sup>
132	T-4	Ground	167	80	1.0		S.E.V.	M β	.3850*	.5055	.6114	.6636	.8027	.8712	1.053	1.143	1.501*
133	T-4	M.P. 4 RMS	167	80	1.0		Wetbull	b ϕ	1.383*	1.403*	1.292	1.276	1.972	1.333	1.143	1.218	1.282*
								X <sub>0</sub>	59.20	48.67	42.41	39.97	35.02	32.87	28.64	27.00	22.20
									52.24	42.90	37.57	35.43	29.88	29.06	25.50	23.99	19.67

Miscellaneous

Code No.	Heat Treat	Surf. Fin.	Freq.	Temp	V-Notch	Normal	Wetbull	X <sub>0</sub>	1x10 <sup>3</sup>	1x10 <sup>4</sup>	5x10 <sup>4</sup>	1x10 <sup>5</sup>	5x10 <sup>5</sup>	1x10 <sup>6</sup>	5x10 <sup>6</sup>	1x10 <sup>7</sup>	1x10 <sup>8</sup>
134	T-4	LTB	167	80	5.2		Wetbull	X <sub>0</sub> ϕ	4.265*	4.314	4.294	4.181	4.178	4.332	4.248	4.216	4.323*
									51.19	39.27	32.62	30.12	25.02	23.10	19.19	17.72	13.59
									32.04	24.44	20.35	19.02	15.81	14.35	12.03	11.15	8.456
135	T-4			80			Normal	σ	4.950*	3.797	3.155	2.913	2.420	2.235	1.857*	1.714*	1.315*
									67.72	51.95	43.17	39.86	33.11	30.57	25.40	23.45	17.99

PLATE BENDING (Completely Reversed)

Miscellaneous

Code No.	Heat Treat	Surf. Fin.	Freq.	Temp	V-Notch	Normal	Wetbull	X <sub>0</sub> ϕ <th>1x10<sup>3</sup></th> <th>1x10<sup>4</sup></th> <th>5x10<sup>4</sup></th> <th>1x10<sup>5</sup></th> <th>5x10<sup>5</sup></th> <th>1x10<sup>6</sup></th> <th>5x10<sup>6</sup></th> <th>1x10<sup>7</sup></th> <th>1x10<sup>8</sup></th>	1x10 <sup>3</sup>	1x10 <sup>4</sup>	5x10 <sup>4</sup>	1x10 <sup>5</sup>	5x10 <sup>5</sup>	1x10 <sup>6</sup>	5x10 <sup>6</sup>	1x10 <sup>7</sup>	1x10 <sup>8</sup>
136	T-3	E.P.	30	80	1.0		Wetbull	X <sub>0</sub> ϕ	2.629*	2.568*	2.903*	2.739	2.404*	2.277*	2.835*	2.748*	2.655*
									64.90	47.28	37.90	34.45	27.61	25.09	20.12	18.29	13.32
									60.10	43.85	34.88	31.83	25.69	23.42	18.55	16.89	12.33

2024 ALUMINUM (Cont'd)  
(EXTRUSIONS)

Composition: See Page 166  
(\* Extrapolated Values)

S<sub>u</sub> = 61-81 ksi  
S<sub>y</sub> = 45-61 ksi

Code No.	TEST CONDITIONS				FATIGUE STRENGTH DISTRIBUTIONS AND THEIR PARAMETERS									
	Heat Treat	Surr. Fin.	Temp. °F	R <sub>r</sub>	Other	LIFE IN CYCLES								
						1x10 <sup>3</sup>	1x10 <sup>4</sup>	5x10 <sup>4</sup>	1x10 <sup>5</sup>	5x10 <sup>5</sup>	1x10 <sup>6</sup>	5x10 <sup>6</sup>	1x10 <sup>7</sup>	1x10 <sup>8</sup>

AXIAL (Completely Reversed)  
Miscellaneous

137	T-6	M.P.	60	80	3.4		2.389*	2.412	2.551	2.513	2.475	2.475	2.475	2.475*
							52.27	34.39	25.68	22.64	16.89	14.89	11.11	9.803
							41.96	27.57	20.36	18.00	13.47	11.88	8.870	7.820
138	T-3			80	1.0		1.072*	1.151	1.410	.7409	1.330	.9247	.7388*	1.081*
							67.06	47.39	37.25	33.32	26.28	23.56	18.44	16.66
							63.28	44.57	34.63	31.74	24.52	22.34	17.56	15.71

S<sub>u</sub> = 67 ksi  
S<sub>y</sub> = 50 ksi

2024 ALCLAD ALUMINUM

Composition: See Page 166  
(\* Extrapolated Values)

AXIAL (Completely Reversed)  
Miscellaneous

139			16.7	80	1.0		1.706*	1.485	1.716*	1.716*	1.716*	1.716*	1.716*	1.716*
							58.84	47.27	40.61	38.02	32.64	30.57	26.24	24.57
							53.84	43.57	37.15	34.78	29.86	27.96	24.01	22.48
140				80	1.0		.1980*	.2978*	.3962	.4480	.5959	.6738	.8963*	1.013*
							63.58	42.27	31.78	28.10	21.13	18.68	14.04	12.42
141	T-3	Milled Edges	20	80	2.5		1.833*	1.833	1.833	1.833	1.833	1.833	1.833*	1.833*
							38.73	24.72	18.07	15.78	11.53	10.08	7.366	6.435
							32.98	21.05	15.38	13.44	9.825	8.583	6.272	5.480

S<sub>u</sub> = 55-70 ksi  
S<sub>y</sub> = 37-52 ksi

2025 ALUMINUM

Composition: See Page 166  
(\* ) Extrapolated Values

Code No.	TEST CONDITIONS				FATIGUE STRENGTH DISTRIBUTIONS AND THEIR PARAMETERS													
	Heat Treat	Surf. Fin.	Freq.	Temp. °F	K <sub>t</sub>	Other	DISP.	Param. q	LIFE IN CYCLES									
									1x10 <sup>3</sup>	1x10 <sup>4</sup>	5x10 <sup>4</sup>	1x10 <sup>5</sup>	5x10 <sup>5</sup>	1x10 <sup>6</sup>	5x10 <sup>6</sup>	1x10 <sup>7</sup>	1x10 <sup>8</sup>	

ROTARY BEAM BENDING

Effect of Heat Treatment

142	HT-5		M.P.	100	80	1.0			6.340*	5.595*	5.940*	5.888*	6.430*	5.740*	6.392	6.392	5.740*	6.392	6.392	5.740*
									55.25	44.81	38.71	36.34	31.40	29.48	25.47	25.47	29.48	25.47	23.91	19.39
									45.65	37.84	32.36	30.43	25.87	24.79	21.01	21.01	24.79	21.01	19.72	16.30
143	T-6		M.P.	167	80	1.0			1.148*	.9687*	1.340	1.214	1.433	1.127	.9368	1.059	1.481*	1.059	1.059	1.481*
									65.43	51.47	43.60	40.54	34.33	31.89	26.97	25.09	19.79	26.97	25.09	19.79
									60.91	48.09	40.36	37.67	31.68	29.71	25.21	23.41	18.23	25.21	23.41	18.23
144	HT-6		Electropolish	167	80	1.0			1.552*	1.552*	1.552*	1.552*	1.552	1.552	1.619*	1.552*	1.552*	1.552*	1.552*	1.552*
									55.83	42.09	34.54	31.73	26.04	23.91	19.63	18.03	13.59	19.63	18.03	13.59
									52.59	39.64	32.53	29.88	24.52	22.52	18.46	16.98	12.80	18.46	16.98	12.80
145	HT-7			167	80	1.0			1.451*	1.563*	1.467*	1.429*	1.346	1.581	1.518	1.493	1.419*	1.518	1.493	1.419*
									45.17	36.94	32.05	30.15	26.16	24.66	21.40	20.13	16.44	21.40	20.13	16.44
									38.33	31.08	27.16	25.62	22.36	20.72	18.07	17.03	13.98	18.07	17.03	13.98

Effect of Surface Treatment

146	HT-5	MP	As Is	100	80	1.0			6.340*	5.595*	5.940*	5.888*	6.430*	5.740*	6.392	6.392	5.740*	6.392	6.392	5.740*
									55.25	44.81	38.71	36.34	31.40	29.48	25.47	25.47	29.48	25.47	23.91	19.39
									45.65	37.84	32.36	30.43	25.87	24.79	21.01	21.01	24.79	21.01	19.72	16.30
147	HT-5	MP-A	nodized	167	80	1.0			1.498*	1.498*	1.498*	1.498*	1.498*	1.498*	1.498	1.498	1.498*	1.498	1.498	1.498*
									53.36	44.63	39.39	37.32	32.94	31.22	27.55	26.11	21.84	27.55	26.11	21.84
									47.84	40.01	35.31	33.46	29.54	27.99	24.70	23.41	19.58	24.70	23.41	19.58



S<sub>y</sub> = 55-70 ksi  
S<sub>u</sub> = 37-52 ksi

2025 ALUMINUM (Cont'd)

Composition: See Page 165  
(\* Extrapolated Values)

Code No.	TEST CONDITIONS				FATIGUE STRENGTH DISTRIBUTIONS AND THEIR PARAMETERS												
	Heat Treat	Surt. Min.	Freq. M.	Temp °F	R <sub>r</sub>	Other	DIST.	Param.	LIFE IN CYCLES								
									1x10 <sup>3</sup>	1x10 <sup>4</sup>	5x10 <sup>4</sup>	1x10 <sup>5</sup>	5x10 <sup>5</sup>	1x10 <sup>6</sup>	5x10 <sup>6</sup>	1x10 <sup>7</sup>	1x10 <sup>8</sup>

ROTARY BEAM BENDING

Effect of Stress Concentration

148	HT-5	MP	100	80	1.0		Webull	b θ X <sub>o</sub>	6.340* 55.25 45.65	5.595* 44.81 37.84	5.940* 38.71 32.36	5.888* 36.34 30.43	6.430* 31.40 25.87	5.740* 29.48 24.79	6.392 25.47 21.01	6.392 23.91 19.72	5.740* 19.39 16.50
149	HT-5	MP	100	80	1.9		Webull	b θ X <sub>o</sub>	10.11* 62.37 42.23	10.49* 51.67 34.40	9.399* 47.65 33.27	9.341* 39.47 27.63	10.40* 36.40 24.34	10.07 30.16 20.45	9.826 27.81 19.06	8.494* 21.24 15.40	

AXIAL (Completely Reversed)

Effect of Stress Concentration

150	HT-5	M.P.	100	80	1.0		S.E.V.	β M X <sub>o</sub>	.5422* 51.68	.6644* 42.18	.7657* 36.59	.8140* 34.42	.9381 29.87	.9973 28.10	1.149 24.38	1.221 22.93	1.497 18.71
151	HT-5	M.P.	100	80	1.9		Webull	b θ X <sub>o</sub>	.6534* 27.98 25.73	.7215* 21.02 19.27	1.027* 17.27 15.58	.9060* 15.82 14.37	.5325* 12.87 11.87	.9701* 11.88 10.75	.7629 9.688 8.865	.6592 8.870 8.154	.9261* 6.684 6.064

HT-5: Solution H.T., 960°F, 1 hr; W.Q., Aged 340°F 10 hrs., A.C.

HT-6: Reheat 370°F 3/4 hrs., W.Q., Aged 330°F 15 hrs.

HT-7: Solution H.T., 916-930°F, Aged 210°F-6 hrs., A.C., Reheat to 315°F 10-hrs., A.C.

S<sub>y</sub> = 77.5 ksi  
 S<sub>u</sub> = 60.5 ksi

2026 ALUMINUM

Composition: See Page 166  
 (\*) Extrapolated

Code No.	TEST CONDITIONS				FATIGUE STRENGTH DISTRIBUTIONS AND THEIR PARAMETERS												
	Heat Treat	Surt. Fin.	Temp. Req.	Temp. M	K <sub>t</sub>	Other	DIST.	Param.	LIFE IN CYCLES								
									1x10 <sup>3</sup>	1x10 <sup>4</sup>	5x10 <sup>4</sup>	1x10 <sup>5</sup>	5x10 <sup>5</sup>	1x10 <sup>6</sup>	5x10 <sup>6</sup>	1x10 <sup>7</sup>	1x10 <sup>8</sup>

AXIAL (Completely Reversed)  
 Effect of Stress Concentration

Code No.	Heat Treat	Surt. Fin.	Temp. Req.	Temp. M	K <sub>t</sub>	Other	DIST.	Param.	1x10 <sup>3</sup>	1x10 <sup>4</sup>	5x10 <sup>4</sup>	1x10 <sup>5</sup>	5x10 <sup>5</sup>	1x10 <sup>6</sup>	5x10 <sup>6</sup>	1x10 <sup>7</sup>	1x10 <sup>8</sup>
152	Fully Heat Treated			80	1.0		Normal	n = 0	2.485* 49.12	2.140* 42.30	1.928* 38.10	1.843 36.42	1.660 32.81	1.587 31.36	1.429 28.25	1.366 27.01	1.177* 23.26
153	Fully Heat Treated		80		Ho-N	Transv. Hole	Normal	n = 0	2.855* 34.24	2.197* 26.35	1.829* 21.94	1.691 20.27	1.408 16.88	1.301 15.60	1.083 12.99	1.001 12.00	.7706* 9.241

S<sub>u</sub> = 59-67 ksi  
 S<sub>y</sub> = 46-54 ksi

2219 ALUMINUM

Composition: See Page 165  
 (\*) Extrapolated Values

Code No.	TEST CONDITIONS		FATIGUE STRENGTH DISTRIBUTIONS AND THEIR PARAMETERS												
	Heat Treat	Surf. Fin.	Temp. °F	K <sub>t</sub>	Other	DIST.	Param.	LIFE IN CYCLES							
								1x10 <sup>3</sup>	1x10 <sup>4</sup>	5x10 <sup>4</sup>	1x10 <sup>5</sup>	5x10 <sup>5</sup>	1x10 <sup>6</sup>	5x10 <sup>6</sup>	1x10 <sup>7</sup>

AXIAL (Completely Reversed)  
 Effect of Heat Treatment

Code No.	Heat Treat	M.P.	Temp. °F	K <sub>t</sub>	Other	S.F.V.	Weibull	β	M	LIFE IN CYCLES								
										1x10 <sup>3</sup>	1x10 <sup>4</sup>	5x10 <sup>4</sup>	1x10 <sup>5</sup>	5x10 <sup>5</sup>	1x10 <sup>6</sup>	5x10 <sup>6</sup>	1x10 <sup>7</sup>	1x10 <sup>8</sup>
154	T-87	M.P.	80	1.0	Hot Rolled					6.559*	6.455	6.029	6.218	5.979	5.798	5.463*	5.368*	5.206*
										53.99	41.06	33.91	31.28	25.79	23.75	19.61	18.06	13.73
155	T-62	M.P.	80	1.0	Hot Rolled					.3830*	.4826	.5672	.6081	.7148	.7663	.9007*	.9656*	1.216*
										39.51	31.35	26.67	24.88	21.17	19.74	16.80	15.67	12.43

Effect of Stress Concentration

Code No.	Heat Treat	M.P.	Temp. °F	K <sub>t</sub>	Other	S.F.V.	Weibull	β	M	LIFE IN CYCLES								
										1x10 <sup>3</sup>	1x10 <sup>4</sup>	5x10 <sup>4</sup>	1x10 <sup>5</sup>	5x10 <sup>5</sup>	1x10 <sup>6</sup>	5x10 <sup>6</sup>	1x10 <sup>7</sup>	1x10 <sup>8</sup>
156	T-62	M.P.	80	1.0						.3830*	.4826	.5672	.6081	.7148	.7663	.9007*	.9656*	1.216*
										39.51	31.35	26.67	24.88	21.17	19.74	16.80	15.67	12.43
157	T-62	M.P.	80	3.5		Normal				2.014*	1.268	.9173	.7979	.5773	.5021	.3633*	.3160*	.1988*
										28.56	17.97	13.00	11.31	8.183	7.118	5.150	4.479	2.819

Effect of Test Temperature

Code No.	Heat Treat	M.P.	Temp. °F	K <sub>t</sub>	Other	S.F.V.	Weibull	β	M	LIFE IN CYCLES								
										1x10 <sup>3</sup>	1x10 <sup>4</sup>	5x10 <sup>4</sup>	1x10 <sup>5</sup>	5x10 <sup>5</sup>	1x10 <sup>6</sup>	5x10 <sup>6</sup>	1x10 <sup>7</sup>	1x10 <sup>8</sup>
158			400	1.0		Normal				3.431*	2.659*	2.225	2.061	1.724	1.597	1.336	1.238	.9595*
										61.03	47.30	39.58	36.66	30.67	28.41	23.77	22.02	17.06
159			600	1.0		S.F.V.				.4197*	.5413*	.6467	.6982	.9341	.9005	1.075	1.161	1.498*
										42.33	32.82	27.47	25.44	21.30	19.73	16.51	15.29	11.86

Composition: See Page 166  
 (\*) Extrapolated Values

2618 ALUMINUM

S<sub>u</sub> = 47-61 ksi  
 S<sub>y</sub> = 41-52 ksi

Code No.	TEST CONDITIONS				FATIGUE STRENGTH DISTRIBUTIONS AND THEIR PARAMETERS												
	Heat Treat	Surf. Fin.	Freq.	Temp. M	K <sub>t</sub>	Other	DIST.	Param.	LIFE IN CYCLES								
									1x10 <sup>3</sup>	1x10 <sup>4</sup>	5x10 <sup>4</sup>	1x10 <sup>5</sup>	5x10 <sup>5</sup>	1x10 <sup>6</sup>	5x10 <sup>6</sup>	1x10 <sup>7</sup>	1x10 <sup>8</sup>

ROTARY BEAM BENDING  
 Effects of Heat Treatment and Manufacturing Processes

160	T-61	Mechanical Polish - 4 RMS	83	80	1.0	Hot Hammer Forged	L.E.V.	M B	.6513 51.65	.7902 42.57	.8588 39.17	1.041 32.28	1.132 29.70	1.373 24.48	1.493* 22.53	1.968* 17.08
161	T-6	Mechanical Polish - 4 RMS	83	80	1.0	Hot Rolled	L.E.V.	M B	.4545 51.13	.5614 41.39	.6149 37.79	.7596 30.59	.8320 27.93	1.027* 22.61	1.125* 20.64	1.522* 15.26

Effect of Stress Concentration

162	T-6	Mechanical Polish - 4 RMS	83	80	1.0	Hot Rolled	L.E.V.	M B	.4545 51.13	.5614 41.39	.6149 37.79	.7596 30.59	.8320 27.93	1.027* 22.61	1.125* 20.64	1.522* 15.26
163	T-6	Mechanical Polish - 4 RMS	83	80	2.4	Hot Rolled	Wetbull	q	2.532* 53.05 48.16	2.408 35.77 32.57	2.401 24.12 21.97	2.248* 18.31 16.73	2.248* 16.26 14.86	2.248* 12.34 11.28	2.248* 10.96 10.02	2.248* 7.394 6.759

Effect of Test Temperature

164	T-61	Mechanical Polish - 4 RMS	83	400	2.4	Hammer Forged	S.E.V.	M B	.3122 38.57	.4522 26.63	.5304 22.71	.7682 15.68	.9011 13.36	1.305* 9.231	1.530* 7.870	2.600* 4.633
165	T-61	Mechanical Polish - 4 RMS	83	400	2.4	Hammer Forged	Wetbull	q	4.679* 53.13 44.05	4.701 33.87 28.06	4.530 21.59 17.99	4.529 15.76 13.13	4.530 13.76 11.47	4.530 10.04 8.375	4.529 8.773 7.313	4.529* 5.593 4.662

Composition: See Page 166  
 (\*) Extrapolated Values

2618 ALUMINUM (Cont'd)

S<sub>u</sub> = 47-61 ksi  
 S<sub>y</sub> = 41-52 ksi

Code No.	TEST CONDITIONS			FATIGUE STRENGTH DISTRIBUTIONS AND THEIR PARAMETERS													
	Heat Treat	Surf. Fin.	Freq.	Temp	K <sub>t</sub>	Other	Dist.	Param.	LIFE IN CYCLES								
									1x10 <sup>3</sup>	1x10 <sup>4</sup>	5x10 <sup>4</sup>	1x10 <sup>5</sup>	5x10 <sup>5</sup>	1x10 <sup>6</sup>	5x10 <sup>6</sup>	1x10 <sup>7</sup>	1x10 <sup>8</sup>

ROTARY BEAM BENDING

Effect of Test Temperature

Code No.	Heat Treat	Surf. Fin.	Freq.	Temp	K <sub>t</sub>	Other	Dist.	Param.	1x10 <sup>3</sup>	1x10 <sup>4</sup>	5x10 <sup>4</sup>	1x10 <sup>5</sup>	5x10 <sup>5</sup>	1x10 <sup>6</sup>	5x10 <sup>6</sup>	1x10 <sup>7</sup>	1x10 <sup>8</sup>
166	T-6	Mechanical Polish 4 RMS	83	80	1.0	Hot Rolled	L.F.V.	β	.4545 51.13	.5614 41.39	.6149 37.79	.7596 30.59	.8320 27.93	1.027* 22.61	1.125* 20.64	1.522* 15.26	
167	T-6		83	250	1.0		Webull	θ	5.376 52.19 45.52	5.519 41.46 36.05	5.750 37.55 32.47	5.565 29.83 25.91	5.250 27.01 23.83	5.847* 21.46 18.52	5.847* 19.44 16.77	5.848* 13.98 12.07	
168	T-6		83	400	1.0		Normal	σ	2.659 47.71	2.104 37.76	1.902 34.13	1.505 27.01	1.361 24.42	1.077 19.32	.9738 17.47	.6967* 12.50	

PLATE BENDING (Completely Reversed)

Effect of Frequency

Code No.	Heat Treat	Surf. Fin.	Freq.	Temp	K <sub>t</sub>	Other	Dist.	Param.	1x10 <sup>3</sup>	1x10 <sup>4</sup>	5x10 <sup>4</sup>	1x10 <sup>5</sup>	5x10 <sup>5</sup>	1x10 <sup>6</sup>	5x10 <sup>6</sup>	1x10 <sup>7</sup>	1x10 <sup>8</sup>
169			24	80	1.0		L.F.V.	β	.5826* 35.01	.6536* 31.21	.7082* 28.81	.7331* 27.83	.7944 25.68	.8224 24.81	.8911 22.89	.9225 22.11	1.034* 19.71
170		Polished	370	80	1.0		Webull	θ	5.996* 41.46 24.36	5.809* 35.61 21.32	5.531* 32.02 19.69	5.427* 30.59 19.00	5.217 27.50 17.43	5.137 26.27 16.77	4.976 23.63 15.30	4.916 22.57 14.70	4.809* 19.39 12.75
171			850	80	1.0		S.E.V.	β	.4651* 41.41	.5371* 35.86	.5940* 32.42	.6203* 31.05	.6860* 28.08	.7163 26.88	.7922 24.31	.8273 23.28	.9554* 20.16

Composition: See Page 166  
 (\*) Extrapolated Values

2618 ALUMINUM (Cont'd)

Code No.	TEST CONDITIONS				FATIGUE STRENGTH DISTRIBUTIONS AND THEIR PARAMETERS												
	Heat Treat	Surf. Fin.	Freq.	Temp. °F	K <sub>t</sub>	Other	DIST.	Param.	LIFE IN CYCLES								
									1x10 <sup>3</sup>	1x10 <sup>4</sup>	5x10 <sup>4</sup>	1x10 <sup>5</sup>	5x10 <sup>5</sup>	1x10 <sup>6</sup>	5x10 <sup>6</sup>	1x10 <sup>7</sup>	1x10 <sup>8</sup>

PLATE BENDING (Completely Reversed)  
 Effect of Frequency

Code No.	Heat Treat	Surf. Fin.	Freq.	Temp. °F	K <sub>t</sub>	Other	DIST.	Param.	1x10 <sup>3</sup>	1x10 <sup>4</sup>	5x10 <sup>4</sup>	1x10 <sup>5</sup>	5x10 <sup>5</sup>	1x10 <sup>6</sup>	5x10 <sup>6</sup>	1x10 <sup>7</sup>	1x10 <sup>8</sup>
172			1550	80	1.0		Normal	σ	1.992* 35.50	1.773* 31.59	1.634* 29.12	1.577* 28.11	1.454* 25.91	1.404* 25.02	1.294 23.06	1.249 22.26	1.111* 19.81
173		Polished	3835	80	1.0		Webull	σ <sub>y</sub> φ		1.242* 50.18 48.17	1.295* 49.38 39.28	1.295* 45.32 36.05	1.295* 37.14 29.54	1.412* 34.20 26.76	1.133 27.85 22.53	1.165 25.58 20.63	1.508 19.41 14.94

AXIAL (Completely Reversed)  
 Effect of Stress Concentration

Code No.	Heat Treat	Surf. Fin.	Freq.	Temp. °F	K <sub>t</sub>	Other	DIST.	Param.	1x10 <sup>3</sup>	1x10 <sup>4</sup>	5x10 <sup>4</sup>	1x10 <sup>5</sup>	5x10 <sup>5</sup>	1x10 <sup>6</sup>	5x10 <sup>6</sup>	1x10 <sup>7</sup>	1x10 <sup>8</sup>
174	HT-8						Webull	σ <sub>y</sub> φ	1.465* 15.30 14.5C	1.365* 12.58 11.95	1.214* 10.96 10.46	1.152 10.32 9.883	1.006 8.997 8.646	.9412 8.478 8.161	.7585 7.383 7.135	.7423 6.960 6.728	.7423* 5.723 5.532
175	HT-8		392	392	1.0	Transv. Hole	L.E.V.	M	1.848* 12.34	2.382* 9.578	2.844 8.022	3.070 7.432	3.666 6.224	3.957 5.767	4.724 4.830	5.099 4.474	6.572* 3.472

HT-8: A.C. from 986°F, Annealed at 680°F for 2 hrs and cooled at 18°F/hr to 80°F

Composition: See Page 166  
 (\*) Extrapolated Values

5052 ALUMINUM

Code No.	TEST CONDITIONS		FATIGUE STRENGTH DISTRIBUTIONS AND THEIR PARAMETERS											
	Heat Treat	Surt. Fin.	Freq.	Temp	K <sub>r</sub>	Other	DIST.	LIFE IN CYCLES						
								1x10 <sup>3</sup>	1x10 <sup>4</sup>	5x10 <sup>4</sup>	1x10 <sup>5</sup>	5x10 <sup>5</sup>	1x10 <sup>6</sup>	5x10 <sup>6</sup>

AXIAL (Completely Reversed)  
 Effect of Heat Treatment

Code No.	Heat Treat	Surt. Fin.	Freq.	Temp	K <sub>r</sub>	Other	DIST.	Polish		LIFE IN CYCLES											
								Mechanical	Polish	b	σ	2.968*	2.907*	3.001	2.948	3.070	3.029	2.942*	3.025*	3.045*	
176	H-34		33	80	1.0	Hot Rolled	Wetbull	σ	45.20	33.74	35.88	26.92	22.73	28.48	24.24	22.61	19.24	17.95	14.39	13.33	10.57
177	H-32		33	80	1.0	Hot Rolled	Wetbull	σ	45.82	36.54	31.19	29.15	23.50	24.88	23.24	19.85	18.54	14.99	14.99	14.99	11.96
								b	2.058*	2.001*	2.001	2.040	2.001	2.001	2.001	2.038*	2.002*	2.038*	2.002*	2.001*	2.001*

S<sub>u</sub> = 36 ksi  
 S<sub>y</sub> = 18 ksi

5056 ALUMINUM

Composition: See Page 166  
 (\*) Extrapolated Values

AXIAL (Completely Reversed)  
 Effect of Stress Concentration

Code No.	Heat Treat	S.E.V.	Ho-N	Temp	K <sub>t</sub>	Other	DIST.	Rolled		LIFE IN CYCLES											
								M	σ	1.946*	1.946*	1.946	1.946	1.946	1.946	1.946	1.946	1.946	1.946*	2.067*	
178			1.0	80	1.0	Rolled	Wetbull	σ	34.27	27.66	30.36	24.51	22.52	26.90	23.84	21.90	17.68	17.06	14.96	14.96	11.96
179			1.0	80	1.0	Rolled	Wetbull	M	3249*	18.81	4206*	18.81	15.70	14.52	11.22	9.367	8.667	8.667	8.667	8.667	6.694
								σ	27.66	24.51	24.51	22.52	21.71	19.95	19.24	17.68	17.06	17.06	17.06	17.06	17.06
								M	.3249*	18.81	.4206*	18.81	15.70	14.52	11.22	9.367	8.667	8.667	8.667	8.667	6.694

Composition: See Page 166  
 (\*) Extrapolated Values

5083 ALUMINUM

$S_u = 50 \text{ ksi}$   
 $S_y = 34.4 \text{ ksi}$

Code No.	TEST CONDITIONS				FATIGUE STRENGTH DISTRIBUTIONS AND THEIR PARAMETERS											
	Heat Treat	Gurr. Fin.	Temp. °F	$R_r$	Other	DIST.	Form.	LIFE IN CYCLES								
								$1 \times 10^3$	$1 \times 10^4$	$5 \times 10^4$	$1 \times 10^5$	$5 \times 10^5$	$1 \times 10^6$	$5 \times 10^6$	$1 \times 10^7$	$1 \times 10^8$

AXIAL (Completely Reversed)  
 Miscellaneous

Code No.	Heat Treat	Gurr. Fin.	Temp. °F	$R_r$	Other	DIST.	Form.	$1 \times 10^3$	$1 \times 10^4$	$5 \times 10^4$	$1 \times 10^5$	$5 \times 10^5$	$1 \times 10^6$	$5 \times 10^6$	$1 \times 10^7$	$1 \times 10^8$
180	H-113		80	1.0		Webull	ox		1.440	1.669	1.490*	1.069*	1.355*	.9732*	1.669*	
									44.44	40.78	33.33	30.52	24.98	22.88	17.20	
									42.78	39.06	32.05	29.58	24.09	22.21	16.48	

$S_u = 45 \text{ ksi}$   
 $S_y = 30 \text{ ksi}$

5086 ALUMINUM

Composition: See Page 167  
 (\*) Extrapolated Values

ROTARY BEAM BENDING

Miscellaneous

Code No.	M.P.	Temp. °F	$R_r$	Normal	Form.	$1 \times 10^3$	$1 \times 10^4$	$5 \times 10^4$	$1 \times 10^5$	$5 \times 10^5$	$1 \times 10^6$	$5 \times 10^6$	$1 \times 10^7$	$1 \times 10^8$
181	H-34	33	1.0			2.372*	1.990	1.845	1.547	1.434	1.203	1.115*	.8675*	
						37.03	31.06	28.79	24.15	22.39	18.78	17.41	13.53	

PLATE BENDING  
 Effect of Heat Treatment

Code No.	Heat Treat	Gurr. Fin.	Temp. °F	$R_r$	Other	DIST.	Form.	$1 \times 10^3$	$1 \times 10^4$	$5 \times 10^4$	$1 \times 10^5$	$5 \times 10^5$	$1 \times 10^6$	$5 \times 10^6$	$1 \times 10^7$	$1 \times 10^8$
182	H-112	Milled Edges	33	1.0		S.F.V.	M	.6659*	.8964	1.103*	1.206*					
								26.85	19.94	16.20	14.82					
183	H-32	Ground and Milled Edges	33	1.0		L.F.V.	M	.2892*	.4526	.6190*	.7083*					
								25.34	16.19	11.84	10.34					



5154 ALUMINUM  
Composition: See Page 167  
(\* Extrapolated Values)

Code No.	TEST CONDITIONS				FATIGUE STRENGTH DISTRIBUTIONS AND THEIR PARAMETERS											
	Heat Treat	Surf. Fin.	Freq.	Temp °F	K <sub>t</sub>	Other	DIST.	Param.	LIFE IN CYCLES							
									1x10 <sup>3</sup>	1x10 <sup>4</sup>	5x10 <sup>4</sup>	1x10 <sup>5</sup>	5x10 <sup>5</sup>	1x10 <sup>6</sup>	5x10 <sup>6</sup>	1x10 <sup>7</sup>

PLATE BENDING (Completely Reversed)  
Miscellaneous

Code No.	Heat Treat	Surf. Fin.	Freq.	Temp °F	K <sub>t</sub>	Other	DIST.	Param.	1x10 <sup>3</sup>	1x10 <sup>4</sup>	5x10 <sup>4</sup>	1x10 <sup>5</sup>	5x10 <sup>5</sup>	1x10 <sup>6</sup>	5x10 <sup>6</sup>	1x10 <sup>7</sup>	1x10 <sup>8</sup>
184	H-34			80	1.0	Tubes	Weibull	β	1.578*	1.578	1.578	1.578	1.578	1.578	1.578*	1.578*	1.578*
								θ	50.28	33.60	25.35	22.45	16.94	15.00	11.32	10.02	6.700
								σ <sub>o</sub>	44.64	29.83	22.50	19.93	15.04	13.32	10.05	8.902	5.949

6061 ALUMINUM  
Composition: See Page 167  
(\* Extrapolated Values)

PLATE BENDING (Completely Reversed)  
Effect of Surface Finish

Code No.	Heat Treat	Surf. Fin.	Freq.	Temp °F	K <sub>t</sub>	Other	DIST.	Param.	1x10 <sup>3</sup>	1x10 <sup>4</sup>	5x10 <sup>4</sup>	1x10 <sup>5</sup>	5x10 <sup>5</sup>	1x10 <sup>6</sup>	5x10 <sup>6</sup>	1x10 <sup>7</sup>	1x10 <sup>8</sup>
185	T-6			80	1.0	Tubes	S.E.V.	β	1.412*	.2361	.3381	.3946	.5651	.6596	.9445	1.102	1.842*
								σ <sub>o</sub>	64.79	38.76	27.07	23.19	16.19	13.87	9.690	8.301	4.966
186	T-6	Polish		80	1.0		Weibull	β	1.052*	1.553*	1.261*	1.291*	.9313	.8536	1.189	1.136	.9662*
								θ	55.90	45.85	39.77	37.44	32.45	30.53	26.58	25.01	20.43
								σ <sub>o</sub>	53.04	42.76	37.48	35.25	30.89	29.12	25.11	23.67	19.43
187	T-6	Machine		80	1.0		S.E.V.	β	.2969*	.3567*	.4056*	.4287	.4874	.5152	.5858	.6191	.7439*
								σ <sub>o</sub>	53.90	44.85	39.45	37.32	32.83	31.06	27.32	25.85	21.51
188	T-6	As Rolled		80	1.0		S.E.V.	β	.1829*	.2725*	.3602*	.4062*	.5368	.6053	.8000*	.9021*	1.344*
								σ <sub>o</sub>	79.67	53.46	40.45	35.87	27.14	24.07	18.21	16.15	10.83

S<sub>u</sub> = 47-56 ksi  
 S<sub>y</sub> = 29-33 ksi

5456 ALUMINUM

Composition: See Page 167  
 (\*) Extrapolated Values

+Code No.	TEST CONDITIONS				FATIGUE STRENGTH DISTRIBUTIONS AND THEIR PARAMETERS												
	Heat Treat	Surf. Fin.	Freq.	Temp °F	K <sub>t</sub>	Other	DIST.	Param.	LIFE IN CYCLES								
									1x10 <sup>3</sup>	1x10 <sup>4</sup>	5x10 <sup>4</sup>	1x10 <sup>5</sup>	5x10 <sup>5</sup>	1x10 <sup>6</sup>	5x10 <sup>6</sup>	1x10 <sup>7</sup>	1x10 <sup>8</sup>

ROTARY BEAM BENDING

Miscellaneous

189	H-311		80	1.0														
		L.F.V.	β M															
		1.041	1.328*	1.474*	1.880*	2.088*	2.662*	2.956*	4.185*									
		40.91	32.08	28.89	22.66	20.41	16.00	14.41	10.18									

AXIAL (Completely Reversed)  
 Effect of Heat Treatment

190	H-311		80	1.0														
		Webull	β M															
		7.549	7.122	6.198	6.437	6.235	6.160*	6.011*	5.956*	5.806*								
		54.49	40.15	32.42	29.58	23.89	21.79	17.60	16.05	11.83								
		36.09	27.27	23.23	20.90	17.08	15.64	12.74	11.65	8.661								
191	H-321																	
		1.303*	1.481	1.560	1.562	1.562	1.562	.9340	1.135*	.8119*								
		50.29	45.47	43.54	39.29	37.59	37.59	33.62	32.28	27.70								
		45.09	40.30	38.38	34.63	33.13	30.83	29.25	25.57									

Miscellaneous

192	H-343		80	3.5	Hot Rolled	S.E.V.	β M											
		Webull																
		.4771*	.7212	.9626	1.090	1.454	1.647	2.199*	2.490*	3.763*								
		27.79	18.39	13.78	12.16	9.117	8.051	6.032	5.326	3.524								

S<sub>u</sub> = 100 ksi  
S<sub>y</sub> = 90 ksi

7001 ALUMINUM

Composition: See Page 167  
(\* ) Extrapolated Values

Code No.	TEST CONDITIONS						FATIGUE STRENGTH DISTRIBUTIONS AND THEIR PARAMETERS									
	Heat Treat	Surt. Fin.	Freq.	Temp.	K <sub>t</sub>	Other	DIST.	Param.	LIFE IN CYCLES							
									1x10 <sup>3</sup>	1x10 <sup>4</sup>	5x10 <sup>4</sup>	1x10 <sup>5</sup>	5x10 <sup>5</sup>	1x10 <sup>6</sup>	5x10 <sup>6</sup>	1x10 <sup>7</sup>

AXIAL (Completely Reversed)  
Effect of Grain Direction

Code No.	Heat Treat	Surt. Fin.	Freq.	Temp.	K <sub>t</sub>	Other	DIST.	Param.	LIFE IN CYCLES								
									1x10 <sup>3</sup>	1x10 <sup>4</sup>	5x10 <sup>4</sup>	1x10 <sup>5</sup>	5x10 <sup>5</sup>	1x10 <sup>6</sup>	5x10 <sup>6</sup>	1x10 <sup>7</sup>	1x10 <sup>8</sup>
193	I-75	Die Forged	30	80	1.0	Longitudinal	Normal	r <sub>o</sub>	4.707*	3.681	3.099	2.878	2.424	2.251	1.895	1.760*	1.376*
									60.65	47.43	39.94	37.09	31.23	29.00	24.42	22.68	17.73
194	I-75	Transv.	30	80	1.0	Transv.	Webull	r <sub>o</sub>	2.289*	2.198	2.318	2.282	2.208	2.198	2.198	2.198*	2.198*
									63.12	50.58	43.34	40.55	34.73	32.50	27.84	26.04	20.87
195	I-75	Longitudinal	30	80	1.0	Longitudinal	Webull	r <sub>o</sub>	3.364*	3.457*	3.485	3.389	3.279	3.528	3.446	3.414*	3.322*
									62.22	50.02	42.94	40.20	34.51	32.32	27.74	25.97	20.87
196	I-75	Transv.	30	80	1.0	Transv.	Webull	r <sub>o</sub>	4.195*	4.276	3.864	4.163	3.961	3.911	4.254	4.215*	4.101*
									62.79	50.27	43.03	40.25	34.45	32.22	27.59	25.80	20.66
197	I-75	Longitudinal	30	80	3.0	Longitudinal	Webull	r <sub>o</sub>	2.108*	2.065*	2.065	2.065	2.065	2.065*	2.065*	2.065*	2.065*
									33.85	22.07	16.36	14.38	10.66	9.380	6.956	6.115	3.987
198	I-75	Transv.	30	80	3.0	Transv.	L.F.V.	M	.5115*	.7506*	.9813	1.101	1.439*	1.616*	2.112*	2.371*	3.479*
									29.65	20.20	15.45	13.77	10.53	9.387	7.180	6.397	4.360

Machined

7001 ALUMINUM (Cont'd) Composition: See Page 167  
 (\*) Extrapolated Values

S<sub>y</sub> = 100 ksi  
 S<sub>u</sub> = 90 ksi

Code No.	TEST CONDITIONS				FATIGUE STRENGTH DISTRIBUTIONS AND THEIR PARAMETERS												
	Heat Treat	Surf. Fin.	Freq.	Temp.	K <sub>t</sub>	Other	DIST.	Param.	LIFE IN CYCLES								
									1x10 <sup>3</sup>	1x10 <sup>4</sup>	5x10 <sup>4</sup>	1x10 <sup>5</sup>	5x10 <sup>5</sup>	1x10 <sup>6</sup>	5x10 <sup>6</sup>	1x10 <sup>7</sup>	1x10 <sup>8</sup>

AXIAL (Completely Reversed)  
 Effect of Grain Direction

Code No.	Heat Treat	S <sub>y</sub>	S <sub>u</sub>	K <sub>t</sub>	Other	DIST.	Param.	Longitudinal		Transv.						
								Normal	Normal	Normal	Normal					
199	T-75	100	90	3.0		Normal	σ <sub>q</sub>	2.799*	1.812	1.338	1.174	.8665*	.7603*	.5612*	.4924*	.3188*
							σ <sub>p</sub>	34.83	22.56	16.65	14.61	10.78	9.462	6.984	6.128	3.968
200	T-75	100	90	3.0		Normal	σ <sub>q</sub>	5.308*	3.597	2.741	2.438	1.857*	1.652*	1.258*	1.119*	.7588*
							σ <sub>p</sub>	36.72	24.88	18.96	16.86	12.85	11.43	8.708	7.746	5.249

512

Effect of Stress Concentration

Code No.	Heat Treat	S <sub>y</sub>	S <sub>u</sub>	K <sub>t</sub>	Other	DIST.	Param.	Longitudinal		Transverse						
								Webull	Webull	Webull	Webull					
201	T-75	100	90	1.0		Webull <td>σ<sub>q</sub></td> <td>3.364*</td> <td>3.457*</td> <td>3.485</td> <td>3.389</td> <td>3.279</td> <td>3.528</td> <td>3.446</td> <td>3.414*</td> <td>3.322*</td>	σ <sub>q</sub>	3.364*	3.457*	3.485	3.389	3.279	3.528	3.446	3.414*	3.322*
							σ <sub>p</sub>	62.22	50.02	42.94	40.20	34.51	32.32	27.74	25.97	20.87
							σ <sub>q</sub>	47.85	38.24	32.76	30.87	26.68	24.59	21.22	19.91	16.10
202	T-75	100	90	3.0		Webull <td>σ<sub>q</sub></td> <td>2.108*</td> <td>2.065*</td> <td>2.065</td> <td>2.065</td> <td>2.065</td> <td>2.065*</td> <td>2.065*</td> <td>2.065*</td> <td>2.065*</td>	σ <sub>q</sub>	2.108*	2.065*	2.065	2.065	2.065	2.065*	2.065*	2.065*	2.065*
							σ <sub>p</sub>	33.85	22.07	16.36	14.38	10.66	9.380	6.956	6.115	3.987
							σ <sub>q</sub>	29.76	19.43	14.41	12.67	9.396	8.261	6.126	5.385	3.511
203	T-75	100	90	1.0		Webull <td>σ<sub>q</sub></td> <td>4.195*</td> <td>4.276</td> <td>3.864</td> <td>4.163</td> <td>3.961</td> <td>3.911</td> <td>4.254</td> <td>4.215*</td> <td>4.101*</td>	σ <sub>q</sub>	4.195*	4.276	3.864	4.163	3.961	3.911	4.254	4.215*	4.101*
							σ <sub>p</sub>	62.79	50.27	43.03	40.25	34.45	32.22	27.59	25.80	20.66
							σ <sub>q</sub>	51.31	40.94	35.65	32.94	28.43	26.64	22.49	21.07	16.95
204	T-75	100	90	3.0		L.F.V. Webull <td>σ<sub>q</sub></td> <td>.5115*</td> <td>.7506*</td> <td>.9813</td> <td>1.101</td> <td>1.439*</td> <td>1.616*</td> <td>2.112*</td> <td>2.371*</td> <td>3.479*</td>	σ <sub>q</sub>	.5115*	.7506*	.9813	1.101	1.439*	1.616*	2.112*	2.371*	3.479*
							σ <sub>p</sub>	29.65	20.20	15.45	13.77	10.53	9.387	7.180	6.397	4.360

Composition: See Page 167  
 (\*) Extrapolated Values

7001 ALUMINUM (Cont'd)

S<sub>u</sub> = 100 ksi  
 S<sub>y</sub> = 90 ksi

Code No.	TEST CONDITIONS				FATIGUE STRENGTH DISTRIBUTIONS AND THEIR PARAMETERS											
	Heat Treat	Surf. Fin.	Freq.	Temp	K <sub>t</sub>	Other	DIST.	Parab.	LIFE IN CYCLES							
									1x10 <sup>3</sup>	1x10 <sup>4</sup>	5x10 <sup>4</sup>	1x10 <sup>5</sup>	5x10 <sup>5</sup>	1x10 <sup>6</sup>	5x10 <sup>6</sup>	1x10 <sup>7</sup>

AXIAL (Completely Reversed)  
 Effect of Stress Concentration

Code No.	Heat Treat	Surf. Fin.	Freq.	Temp	K <sub>t</sub>	Other	DIST.	Parab.	1x10 <sup>3</sup>	1x10 <sup>4</sup>	5x10 <sup>4</sup>	1x10 <sup>5</sup>	5x10 <sup>5</sup>	1x10 <sup>6</sup>	5x10 <sup>6</sup>	1x10 <sup>7</sup>	1x10 <sup>8</sup>
205	I-75		30	80	1.0	Longitudinal	Normal	n <sub>0</sub>	4.707*	3.681	3.099	2.878	2.424	2.251	1.895	1.760*	1.376*
									60.65	47.43	39.94	37.09	31.23	29.00	24.42	22.68	17.73
206	I-75		30	80	3.0	Transverse	Normal	n <sub>0</sub>	2.799*	1.812	1.338	1.174	.8665*	.7603*	.5612*	.4924*	.3188*
									34.83	22.56	16.65	14.61	10.78	9.462	6.984	6.128	3.968
207	I-75	Machined	30	80	1.0	Transverse	Normal	n <sub>0</sub>	2.289*	2.198	2.318	2.282	2.208	2.198	2.198	2.198*	2.198*
									63.12	50.58	43.34	40.55	34.73	32.50	27.84	26.04	20.87
									54.83	44.10	37.60	35.23	30.27	28.33	24.27	22.71	18.20
208	I-75	Die Forged	30	80	3.0	Transverse	Normal	n <sub>0</sub>	5.308*	3.597	2.741	2.438	1.857*	1.652*	1.258*	1.119*	.7588*
									36.72	24.88	18.96	16.86	12.85	11.43	8.708	7.746	5.249

Miscellaneous

Code No.	Heat Treat	Surf. Fin.	Freq.	Temp	K <sub>t</sub>	Other	DIST.	Parab.	1x10 <sup>3</sup>	1x10 <sup>4</sup>	5x10 <sup>4</sup>	1x10 <sup>5</sup>	5x10 <sup>5</sup>	1x10 <sup>6</sup>	5x10 <sup>6</sup>	1x10 <sup>7</sup>	1x10 <sup>8</sup>
209	I-6	17 RMS	30	80	1.0	Extru- sion	Normal	n <sub>0</sub>	5.073*	3.946*	3.310	3.069	2.575	2.387	2.003	1.857	1.444*
									72.27	56.22	47.17	43.73	36.69	34.02	28.54	26.46	20.58

S<sub>y</sub> = 64 ksi  
 S<sub>u</sub> = 58 ksi

7039 ALUMINUM

Composition: See Page 167  
 (\*) Extrapolated Values

+Code No.	TEST CONDITIONS				FATIGUE STRENGTH DISTRIBUTIONS AND THEIR PARAMETERS											
	Heat Treat	Surf. Fin.	Freq.	Temp °F	K <sub>t</sub>	Other	DISTR.	Param.	LIFE IN CYCLES							
									1x10 <sup>3</sup>	1x10 <sup>4</sup>	5x10 <sup>4</sup>	1x10 <sup>5</sup>	5x10 <sup>5</sup>	1x10 <sup>6</sup>	5x10 <sup>6</sup>	1x10 <sup>7</sup>

AXIAL (Completely Reversed)  
 Effect of Stress Concentration

Code No.	Heat Treat	Surf. Fin.	Freq.	Temp °F	K <sub>t</sub>	Other	DISTR.	Param.	LIFE IN CYCLES							
									1x10 <sup>3</sup>	1x10 <sup>4</sup>	5x10 <sup>4</sup>	1x10 <sup>5</sup>	5x10 <sup>5</sup>	1x10 <sup>6</sup>	5x10 <sup>6</sup>	1x10 <sup>7</sup>
210	I-6			80	1.0	Hot Rolled	Normal	n <sub>0</sub>	3.715*	2.482	2.086	1.393*	1.171*	.7827*		
									43.51	29.06	24.43	16.32	13.72	9.167		
211	I-6		80	3.5	3.756*	Hot Rolled	Webull	n <sub>0</sub>	3.611	3.475	3.430	3.349	3.321	3.270*	3.270*	3.270*
									18.07	12.89	11.15	7.956	6.880	4.245	2.619	4.909
212	I-6		80	8.0	1.707*	Hot Rolled	Webull	n <sub>0</sub>	1.750	1.762	1.762	1.762	1.762*	1.762*	1.762*	1.762*
									25.47	16.80	14.03	9.248	7.727	5.091	4.254	2.341
									12.35	8.080	6.751	4.448	3.716	2.448	2.045	1.126

Composition: See Page 167  
 (\*) Extrapolated Values

7075 ALUMINUM  
 (PLATE AND SHEET)

S<sub>y</sub> = 71-87 ksi  
 S<sub>u</sub> = 67-79 ksi

†Code No.	TEST CONDITIONS				FATIGUE STRENGTH DISTRIBUTIONS AND THEIR PARAMETERS										
	Heat Treat	Surf. Fin.	Temp. Req.	Temp. R	Other	DIST.	LIFE IN CYCLES								
							1x10 <sup>3</sup>	1x10 <sup>4</sup>	5x10 <sup>4</sup>	1x10 <sup>5</sup>	5x10 <sup>5</sup>	1x10 <sup>6</sup>	5x10 <sup>6</sup>	1x10 <sup>7</sup>	1x10 <sup>8</sup>

PLATE BENDING (Completely Reversed)  
 Effect of Stress Concentration

†Code No.	Heat Treat	Surf. Fin.	Temp. Req.	Temp. R	Other	DIST.	LIFE IN CYCLES									
							1x10 <sup>3</sup>	1x10 <sup>4</sup>	5x10 <sup>4</sup>	1x10 <sup>5</sup>	5x10 <sup>5</sup>	1x10 <sup>6</sup>	5x10 <sup>6</sup>	1x10 <sup>7</sup>	1x10 <sup>8</sup>	
213	I-6	Ground	6	80	7.4	Wetbull	b	1.174*	1.517	1.567*	1.580*	1.583*	1.583*	1.583*	1.583*	1.583*
							q	62.73	28.12	15.72	12.23	6.805	5.286	2.940	2.284	1.9869
							X <sub>0</sub>	51.47	19.93	10.85	8.377	4.654	3.615	2.011	1.562	.6750
214	I-6	Ground	6	80	7.9	Wetbull	b	1.043*	1.563	1.677	1.698	1.735*	1.743*	1.743*	1.743*	1.743*
							q	45.30	26.12	17.62	14.85	9.982	8.407	5.636	4.745	2.678
							X <sub>0</sub>	36.95	19.29	12.56	10.51	6.976	5.858	3.928	3.306	1.866

AXIAL (Completely Reversed)  
 Miscellaneous

†Code No.	Heat Treat	Surf. Fin.	Temp. Req.	Temp. R	Other	DIST.	LIFE IN CYCLES									
							1x10 <sup>3</sup>	1x10 <sup>4</sup>	5x10 <sup>4</sup>	1x10 <sup>5</sup>	5x10 <sup>5</sup>	1x10 <sup>6</sup>	5x10 <sup>6</sup>	1x10 <sup>7</sup>	1x10 <sup>8</sup>	
215						L.R.V.	b	.4353*	.6132	.7792	.8638	1.097	1.216	1.546	1.714	2.414*
							q	24.62	17.47	13.75	12.40	9.764	8.807	6.931	6.252	4.438
							X <sub>0</sub>									
216	I-6	Milled Edges	24	80	4.0	Wetbull	b	1.500*	1.557	1.508	1.489	1.618	1.618*	1.618*	1.618*	1.618*
							q	27.15	19.51	15.47	14.00	11.13	10.07	7.994	7.236	5.198
							X <sub>0</sub>	19.66	14.03	11.19	10.15	7.938	7.185	5.702	5.161	3.707

Composition: See Page 167  
 (\*) Extrapolated Values

7075 ALUMINUM (Cont'd)  
 (PLATE AND SHEET)

S<sub>u</sub> = 71-87 ksi  
 S<sub>y</sub> = 67-79 ksi

Code No.	TEST CONDITIONS				FATIGUE STRENGTH DISTRIBUTIONS AND THEIR PARAMETERS											
	Heat Treat	Surt.	Thn.	Temp	R <sub>r</sub>	Other	DIST.	Param	LIFE IN CYCLES							
									1x10 <sup>3</sup>	1x10 <sup>4</sup>	5x10 <sup>4</sup>	1x10 <sup>5</sup>	5x10 <sup>5</sup>	1x10 <sup>6</sup>	5x10 <sup>6</sup>	1x10 <sup>7</sup>

AXIAL (Completely Reversed)  
 Effect of Stress Concentration

Code No.	Heat Treat	Surt.	Thn.	Temp	R <sub>r</sub>	Other	DIST.	Param	1x10 <sup>3</sup>	1x10 <sup>4</sup>	5x10 <sup>4</sup>	1x10 <sup>5</sup>	5x10 <sup>5</sup>	1x10 <sup>6</sup>	5x10 <sup>6</sup>	1x10 <sup>7</sup>	1x10 <sup>8</sup>	
217	T-6	Electropolished	6	80	2.2		Wetbulb	σ <sub>q</sub>	1.774*	2.063*	1.481	1.250*	1.486*	1.358*	1.468*	1.387	1.566*	
								σ <sub>0</sub>	48.06	29.48	20.78	17.90	12.71	10.95	7.775	6.701	4.104	
								σ <sub>0</sub>	40.61	24.31	17.93	15.62	10.96	9.515	6.712	5.812	3.521	
218	T-6	Electropolished	24	80	2.8		Wetbulb	σ <sub>q</sub>	1.656*	1.547	1.744	.7944*	.8959*	.9405*	1.065*	.9338*	1.111*	
								σ <sub>0</sub>	41.60	25.51	18.19	15.47	11.02	9.528	6.792	5.859	3.604	
								σ <sub>0</sub>	36.79	22.74	15.98	14.41	10.23	8.822	6.248	5.419	3.307	
219	T-6	Electropolished	24	80	2.9		Normal	σ <sub>u</sub>	3.743*	2.351	1.698	1.476*	1.066*	.9274*	.6700*	.5824*	.3658*	
								σ <sub>u</sub>	41.80	26.25	18.96	16.48	11.91	10.35	7.481	6.504	4.085	
220	T-6	Electropolished and Milled Edges		80	1.5		Wetbulb	σ <sub>q</sub>	1.308*	1.721*	1.580	1.525	1.407	1.361	1.344	1.344	1.344*	
								σ <sub>0</sub>	49.37	37.70	31.16	28.71	23.74	21.87	18.09	16.67	12.70	
								σ <sub>0</sub>	44.97	33.79	28.10	25.94	21.54	19.88	16.45	15.16	11.56	
221	T-6	Hot Rolled		80	1.0		L.R.V.	M <sub>B</sub>	.2000*	.2434*	.2792	.2962	.3398	.3605	.4135	.4387*	.5339*	
								M <sub>B</sub>	49.84	40.96	35.71	33.66	29.34	27.66	24.11	22.75	18.68	
222	T-6	Hot Rolled		80	2.0		Wetbulb	σ <sub>q</sub>	3.406*	3.441	3.516	3.461	3.350	3.310	3.463*	3.435*	3.406*	
								σ <sub>0</sub>	44.10	31.29	24.62	22.20	17.46	15.74	12.39	11.17	7.929	
								σ <sub>0</sub>	31.56	22.32	17.45	15.81	12.55	11.36	8.826	7.979	5.674	



7075 ALUMINUM (Cont'd)  
(PLATE AND SHEET)

Composition: See Page 167  
(\* Extrapolated Values)

S<sub>u</sub> = 71-87 ksi  
S<sub>y</sub> = 67-79 ksi

Code No.	TEST CONDITIONS				Other	DIST.	Param.	LIFE IN CYCLES							
	Heat Treat	Surf. Fin.	Freq.	Temp.				R <sub>t</sub>	1x10 <sup>3</sup>	1x10 <sup>4</sup>	5x10 <sup>4</sup>	1x10 <sup>5</sup>	5x10 <sup>5</sup>	1x10 <sup>6</sup>	5x10 <sup>6</sup>

FATIGUE STRENGTH DISTRIBUTIONS AND THEIR PARAMETERS

AXIAL (Completely Reversed)  
Effect of Stress Concentration

Code No.	Heat Treat	Surf. Fin.	Freq.	Temp.	R <sub>t</sub>	Hot Rolled		LIFE IN CYCLES																	
						Electropolish	Milled Edges	Normal Weibull	L.E.V. Weibull	b	q	1.500*	1.557	1.508	1.489	1.618	1.618	1.618*	1.618*	1.618*	1.618*	1.618*			
223	T-6		25	80	4.0			27.15	19.51	15.47	14.00	11.13	10.07	7.994	7.236	5.198	3.707								
224	T-6		25	80	5.0			19.66	14.03	11.19	10.15	7.938	7.185	5.702	5.161	3.085									
225	T-6	Electropolish	25	80	1.0			73.23	42.90	29.52	25.13	17.29	14.72	10.12	8.622	5.050	4.317								
226	T-6	Mechanical Polishing	25	80	3.5			62.71	36.67	25.23	21.48	14.78	12.58	8.658	7.370	4.317									
227	T-6		18.3	80	1.0			3.029*	1.939	1.419	1.241	.9085	.7942*	.5814*	.5083*	.3253*									
228	T-6		25	80	1.0			33.73	21.59	15.80	13.81	10.11	8.844	6.474	5.660	3.622									

Effect of Surface Finish

Code No.	Heat Treat	Surf. Fin.	Freq.	Temp.	R <sub>t</sub>	Hot Rolled		LIFE IN CYCLES																	
						Electropolish	Milled Edges	Normal Weibull	L.E.V. Weibull	b	q	1.500*	1.557	1.508	1.489	1.618	1.618	1.618*	1.618*	1.618*	1.618*	1.618*			
227	T-6	E.P.	18.3	80	1.0			49.84	40.96	35.71	33.56	29.34	27.66	24.11	22.73	18.68									
228	T-6	M.P.	25	80	1.0			73.23	42.90	29.52	25.13	17.29	14.72	10.12	8.622	5.050	4.317								

Composition: See Page 167  
 (\*) Extrapolated Values

7075 ALUMINUM  
 (BAR)

S<sub>u</sub> = 71-87 ksi  
 S<sub>y</sub> = 67-79 ksi

Code No.	TEST CONDITIONS				FATIGUE STRENGTH DISTRIBUTIONS AND THEIR PARAMETERS												
	Heat Treat	Surf. Fin.	Freq.	Temp	K <sub>t</sub>	Other	DIST.	Param.	LIFE IN CYCLES								
									1x10 <sup>3</sup>	1x10 <sup>4</sup>	5x10 <sup>4</sup>	1x10 <sup>5</sup>	5x10 <sup>5</sup>	1x10 <sup>6</sup>	5x10 <sup>6</sup>	1x10 <sup>7</sup>	1x10 <sup>8</sup>

ROTARY BEAM BENDING  
 Effect of Grain Direction

Code No.	Heat Treat	Surf. Fin.	Freq.	Temp	K <sub>t</sub>	Other	DISTR.	Param.	LIFE IN CYCLES								
									1x10 <sup>3</sup>	1x10 <sup>4</sup>	5x10 <sup>4</sup>	1x10 <sup>5</sup>	5x10 <sup>5</sup>	1x10 <sup>6</sup>	5x10 <sup>6</sup>	1x10 <sup>7</sup>	1x10 <sup>8</sup>
229	I-6			80	1.0	Longitudinal	Weibull	b	2.668*	2.740*	2.839*	2.820*	2.776	2.758	2.718	2.702	2.651*
									39.95	35.97	33.43	32.39	30.09	29.15	27.09	26.24	23.62
230	I-6			80	1.0	Transverse	Weibull	b	1.278*	1.367*	1.285*	1.301	1.302	1.302	1.302*	1.302*	1.326*
									70.42	47.85	36.45	32.44	24.74	22.02	16.79	14.94	10.14
									32.38	29.02	26.80	26.00	24.22	21.88	21.22	19.17	7.087

7075 ALUMINUM (Cont'd)  
(BAR)

S<sub>u</sub> = 71-87 ksi  
S<sub>y</sub> = 67-79 ksi

Composition: See Page 167  
(\* Extrapolated Values)

Code No.	TEST CONDITIONS				FATIGUE STRENGTH DISTRIBUTIONS AND THEIR PARAMETERS											
	Heat Treat	Surf. Fin.	Temp. °F	r	Other	DIST.	Param.	LIFE IN CYCLES								
								1x10 <sup>3</sup>	1x10 <sup>4</sup>	5x10 <sup>4</sup>	1x10 <sup>5</sup>	5x10 <sup>5</sup>	1x10 <sup>6</sup>	5x10 <sup>6</sup>	1x10 <sup>7</sup>	1x10 <sup>8</sup>

ROTARY BEAM BENDING  
Effect of Frequency

Code No.	Heat Treat	Surf. Fin.	Temp. °F	r	Other	DIST.	Param.	LIFE IN CYCLES								
								1x10 <sup>3</sup>	1x10 <sup>4</sup>	5x10 <sup>4</sup>	1x10 <sup>5</sup>	5x10 <sup>5</sup>	1x10 <sup>6</sup>	5x10 <sup>6</sup>	1x10 <sup>7</sup>	1x10 <sup>8</sup>
231	W.Q. from 876°F, Aged at 250°F, 24 hrs.		80	1.0		Normal Weibull	q	1.746*	1.619*	1.560	1.573	1.496	1.517	1.721	1.680*	1.557*
			80	1.0		Normal Weibull	q	76.10	58.70	48.96	45.30	37.78	34.95	29.20	27.01	20.83
			80	1.0		Normal Weibull	q	63.29	49.25	41.24	38.12	31.94	29.51	24.33	22.56	17.55
232			80	1.0		Normal Weibull	q	7.583*	5.836*	4.859	4.491	3.740	3.456	2.878	2.660	2.047*
			80	1.0		Normal Weibull	q	77.57	59.70	49.71	45.94	38.26	35.35	29.44	27.21	20.94
233			80	1.0		Normal Weibull	q	6.228*	5.594*	5.980	5.943	5.866	5.835	5.578	5.483	5.256*
			80	1.0		Normal Weibull	q	66.73	55.23	48.41	45.73	40.08	37.86	33.18	31.34	25.95
			80	1.0		Normal Weibull	q	38.14	33.60	28.37	26.90	23.75	22.51	20.21	19.27	16.29
234			80	2.0		Normal Weibull	q	2.075*	2.275*	2.166	2.125	2.040	2.007	2.000*	2.000*	2.000*
			80	2.0		Normal Weibull	q	46.59	36.11	30.20	27.97	23.39	21.66	18.12	16.78	13.00
			80	2.0		Normal Weibull	q	41.10	31.56	26.53	24.62	20.67	19.17	16.04	14.86	11.51
235			80	2.0		L.R.V.	β	.2298*	.3016	.3648	.3959	.4787	.5196	.6283	.6819	.8949*
			80	2.0		L.R.V.	β	46.13	35.15	29.07	26.78	22.15	20.41	16.87	15.55	11.85
236			80	2.0		Normal Weibull	q	5.612*	4.646*	4.071	3.846	3.370	3.183	2.789	2.635	2.181*
			80	2.0		Normal Weibull	q	33.75	27.94	24.48	23.13	20.27	19.14	16.77	15.85	13.12

Composition: See Page 16:7  
 (\*) Extrapolated Values

7075 ALUMINUM (Cont'd)  
 (BAR)

S<sub>y</sub> = 71-87 ksi  
 S<sub>u</sub> = 67-79 ksi

Code No.	TEST CONDITIONS				FATIGUE STRENGTH DISTRIBUTIONS AND THEIR PARAMETERS												
	Heat Treat	Surt. Fin.	Freq.	Temp.	K <sub>t</sub>	Other	DIST.	Param.	LIFE IN CYCLES								
									1x10 <sup>3</sup>	1x10 <sup>4</sup>	5x10 <sup>4</sup>	1x10 <sup>5</sup>	5x10 <sup>5</sup>	1x10 <sup>6</sup>	5x10 <sup>6</sup>	1x10 <sup>7</sup>	1x10 <sup>8</sup>

ROTARY BEAM BENDING  
 Effect of Stress Concentration

Code No.	Heat Treat	Surt. Fin.	Freq.	Temp.	K <sub>t</sub>	Other	DIST.	Param.	1x10 <sup>3</sup>	1x10 <sup>4</sup>	5x10 <sup>4</sup>	1x10 <sup>5</sup>	5x10 <sup>5</sup>	1x10 <sup>6</sup>	5x10 <sup>6</sup>	1x10 <sup>7</sup>	1x10 <sup>8</sup>
237	W.Q. from 876°F, Aged at 250°F, 24 hrs.		20	80	1.0		Normal	σ <sub>n</sub>	7.583*	5.836*	4.859	4.491	3.740	2.878	2.660	2.047*	
238			5.3	80	2.0		Wetbull	σ <sub>w</sub>	77.57	59.70	49.71	45.94	38.26	29.44	27.21	20.94	
239			20	80	1.0		Normal	σ <sub>n</sub>	7.583*	5.836*	4.859	4.491	3.740	2.878	2.660	2.047*	
240			20	80	2.0		L.E.V.	β <sub>M</sub>	.2298*	.3016	.3648	.3959	.4787	.6283	.6819	.8949*	
241			62.5	80	1.0		Wetbull	σ <sub>w</sub>	6.228*	5.594*	5.980	5.943	5.866	5.578	5.483	5.256*	
242			62.5	80	2.0		Normal	σ <sub>n</sub>	66.73	55.23	48.41	45.73	40.08	33.18	31.34	25.95	
								σ <sub>w</sub>	38.14	33.60	28.37	26.90	23.75	20.21	19.27	16.29	
								σ <sub>n</sub>	5.612*	4.646*	4.071	3.846	3.370	2.789	2.635	2.181*	
								σ <sub>w</sub>	33.75	27.94	24.48	23.13	20.27	16.77	15.85	13.12	

S<sub>y</sub> = 71-87 ksi  
 S<sub>t</sub> = 67-79 ksi

7075 ALUMINUM (Cont'd)  
 (BAR)

Composition: See Page 167  
 (\*) Extrapolated Values

Code No.	TEST CONDITIONS				Other	DIST.	Param.	FATIGUE STRENGTH DISTRIBUTIONS AND THEIR PARAMETERS								
	Heat Treat	Surt. Fin.	Freq.	Temp °F				K <sub>t</sub>	LIFE IN CYCLES							
								1x10 <sup>3</sup>	1x10 <sup>4</sup>	5x10 <sup>4</sup>	1x10 <sup>5</sup>	5x10 <sup>5</sup>	1x10 <sup>6</sup>	5x10 <sup>6</sup>	1x10 <sup>7</sup>	1x10 <sup>8</sup>

ROTARY BEAM BENDING  
 Effect of Stress Concentration

243	T-6	Longitudinal	Weibull	M <sub>B</sub>	1.0	80	1.0	2.668*	2.740*	2.839*	2.820*	2.776	2.758	2.718	2.702	2.651*
								39.95	35.97	33.43	32.39	30.09	29.15	27.09	26.24	23.62
244	T-6	Notch	Weibull	M <sub>B</sub>	80	1.0	2.024*	1.912	1.842*	1.814*	1.752	2.170	2.122	2.120	2.120*	2.120*
							27.80	23.82	21.38	20.40	18.31	17.50	15.70	14.99	12.84	
							24.76	21.31	19.18	18.33	16.49	15.49	13.93	13.30	11.39	

AXIAL (Completely Reversed)  
 Effect of Stress Concentration

245	T-6	L.E.V.	M <sub>B</sub>	1.0	80	60	Ground - 10 RMS	.1804*	.3207	.4795	.5701	.8523*	1.013*	1.515*	1.801*	3.202*
								79.93	44.96	30.08	25.29	16.92	14.23	9.519	8.005	4.503
246	T-6	L.E.V.	M <sub>B</sub>	3.4	80	60	Ground - 10 RMS	.2129*	.3014	.3842	.4265	.5437	.6036	.7695	.8543	1.209*
								28.95	20.46	16.05	14.45	11.34	10.21	8.014	7.219	5.101

S<sub>y</sub> = 71-87 ksi  
 S<sub>u</sub> = 67-79 ksi

7075 ALUMINUM (Cont'd)  
 (BAR)

Composition: See Page 1627  
 (\*) Extrapolated Values

Code No.	TEST CONDITIONS				FATIGUE STRENGTH DISTRIBUTIONS AND THEIR PARAMETERS											
	Heat Treat	Surf. Fin.	Freq.	Temp °K	K <sub>t</sub>	Other	DIST.	Param.	LIFE IN CYCLES							
									1x10 <sup>3</sup>	1x10 <sup>4</sup>	5x10 <sup>4</sup>	1x10 <sup>5</sup>	5x10 <sup>5</sup>	1x10 <sup>6</sup>	5x10 <sup>6</sup>	1x10 <sup>7</sup>

AXIAL (Completely Reversed)  
 Effect of Stress Concentration

247	1-6	Electropolish	30	80	1.0		Webull	q	1.622*	1.193	.9867	1.168	1.244	1.297	1.387	1.416	1.475*
							Webull	q	74.18	49.63	37.73	33.52	25.51	22.70	17.29	15.38	10.40
							Webull	q	55.54	39.17	30.08	26.51	20.05	17.74	13.37	11.85	7.959
248	1-6	Electropolish	30	80	2.0		Webull	q	1.954	1.747	2.050	1.982	1.890	1.890*	1.890*	1.890*	1.890*
							Webull	q	44.19	30.09	23.02	20.51	15.68	13.97	10.68	9.516	6.483
							Webull	q	39.03	26.76	20.26	18.09	13.88	12.36	9.457	8.425	5.739

S<sub>y</sub> = 71-87 ksi  
 S<sub>u</sub> = 67-79 ksi

7075 ALUMINUM  
 (EXTRUSIONS AND FORGINGS)

Composition: See Page 167  
 (\*) Extrapolated Values

ROTARY BEAM BENDING  
 Effect of Frequency

249		Mechanical & Electropolish	167	80	1.0	Extruded	Normal	q	1.466*	1.561*	1.506	1.526	1.568	1.585	1.618	1.631	1.669*
							Normal	q	53.04	44.98	40.04	38.10	33.95	32.30	28.78	27.38	23.21
							Normal	q	38.19	32.05	28.71	27.26	24.17	22.95	20.36	19.34	16.31
250		Electropolish	50	80	1.0	Extruded	Normal	q	7.953*	6.175	5.175*	4.795	4.018	3.723	3.120	2.891	2.245*
							Normal	q	67.01	52.03	43.60	40.40	33.85	31.37	26.28	24.36	18.91
251		Electropolish	20	80	1.0	Extruded	Normal	q	7.743*	6.515*	5.775	5.482	4.859	4.613	4.088	3.881	3.266*
							Normal	q	48.19	40.55	35.94	34.12	30.24	28.71	25.44	24.16	20.32

Composition: See Page 167  
 (\*) Extrapolated

7075 ALUMINUM (Cont'd)  
 (EXTRUSIONS AND FORGINGS)

S<sub>u</sub> = 71-87 ksi  
 S<sub>y</sub> = 67-79 ksi

Code No.	TEST CONDITIONS				FATIGUE STRENGTH DISTRIBUTIONS AND THEIR PARAMETERS													
	Heat Treat	Surf. Fin.	Freq. Req.	Temp. °F	R <sub>r</sub>	Other	Dist.	Param.	LIFE IN CYCLES									
									1x10 <sup>3</sup>	1x10 <sup>4</sup>	5x10 <sup>4</sup>	1x10 <sup>5</sup>	5x10 <sup>5</sup>	1x10 <sup>6</sup>	5x10 <sup>6</sup>	1x10 <sup>7</sup>	1x10 <sup>8</sup>	

ROTARY BEAM BENDING  
 Effect of Frequency

252			167	80	2.0		Normal	β	.1784*	.2759*	.3742	.4267	.5787	.6598	.8949*	1.020*	1.578*
								M	57.83	37.39	27.57	24.18	17.82	15.63	11.52	10.11	6.537
253			50	80	2.0	Extruded	Wetbull	b	1.534*	1.534	1.534	1.534	1.711	1.619	1.729	1.662	1.768*
								θ	48.66	35.94	29.08	26.54	21.49	19.61	15.87	14.49	10.70
								X <sub>0</sub>	41.14	30.39	24.59	22.44	17.98	16.50	13.26	12.15	8.923
254			20	80	2.0	Wetbull	Wetbull	b	1.509*	1.507*	1.578	1.578	1.471	1.425	1.475	1.443	1.497
								θ	50.37	34.95	27.06	24.23	18.73	16.77	12.99	11.63	8.068
								X <sub>0</sub>	33.84	23.26	17.99	16.11	12.65	11.40	8.771	7.887	5.430

Effect of Manufacturing Processes

255			50	80	1.0	Extrusions	Normal	σ	7.953*	6.175*	5.175*	4.795	4.018	3.723	3.120	2.891	2.245*
								μ	67.01	52.03	43.60	40.40	33.85	31.37	26.28	24.36	18.91
256			50	80	1.0	Forged	Wetbull	b	5.009*	4.775*	4.772	4.918	4.806	4.764	4.874	4.841	4.743*
								θ	72.62	57.48	48.81	45.50	38.64	36.01	30.59	28.51	22.56
								X <sub>0</sub>	42.75	34.69	29.47	27.05	23.25	21.76	18.27	17.09	13.66
257				80	1.0	Wrought	Wetbull	σ		3.089	3.077	3.077	3.077	3.077	3.037	3.211	3.085*
								θ		77.04	68.13	64.62	57.16	54.21	47.95	45.49	38.15
								X <sub>0</sub>		55.45	49.10	46.57	41.19	39.07	34.67	32.39	27.47

7075 ALUMINUM (Cont'd)  
(EXTRUSIONS AND FORGINGS)

Composition: See Page 167  
(\* Extrapolated Values)

S<sub>y</sub> = 71-87 ksi  
S<sub>u</sub> = 67-69 ksi

Code No.	TEST CONDITIONS				FATIGUE STRENGTH DISTRIBUTIONS AND THEIR PARAMETERS													
	Heat Treat	Surf. Fin.	Freq.	Temp °F	K <sub>t</sub>	Other	DIST.	Param	LIFE IN CYCLES								1x10 <sup>7</sup>	1x10 <sup>8</sup>
									1x10 <sup>3</sup>	1x10 <sup>4</sup>	5x10 <sup>4</sup>	1x10 <sup>5</sup>	5x10 <sup>5</sup>	1x10 <sup>6</sup>	5x10 <sup>6</sup>	1x10 <sup>7</sup>		

ROTARY BEAM BENDING  
Effect of Stress Concentration

Code No.	Heat Treat	Surf. Fin.	Freq.	Temp °F	K <sub>t</sub>	Other	DIST.	Param	LIFE IN CYCLES								1x10 <sup>7</sup>	1x10 <sup>8</sup>
									1x10 <sup>3</sup>	1x10 <sup>4</sup>	5x10 <sup>4</sup>	1x10 <sup>5</sup>	5x10 <sup>5</sup>	1x10 <sup>6</sup>	5x10 <sup>6</sup>	1x10 <sup>7</sup>		
258			167	80	1.0	Extrusions	Weibull Normal	b	1.466*	1.561*	1.506	1.526	1.568	1.585	1.618	1.631	1.669*	
									θ	53.04	44.98	40.04	38.10	33.95	32.30	28.78	27.38	23.21
									X <sub>0</sub>	38.19	32.05	28.71	27.26	24.17	22.95	20.36	19.34	16.31
259			167	80	2.0	Extrusions	L.E.V.	β	.1784*	.2759*	.3742	.4267	.5787	.6598	.8949*	1.020*	1.578*	
									M	57.83	37.39	27.57	24.18	17.82	15.63	11.52	10.11	6.537
									n	7.953*	6.175*	5.175*	4.795	4.018	3.723	3.120	2.891	2.245*
260			50	80	1.0	Extrusions	Weibull Normal	n	67.01	52.03	43.60	40.40	33.85	31.37	26.28	24.36	18.91	
									b	1.534*	1.534*	1.534	1.534	1.711	1.619	1.729	1.662	1.768*
									θ	48.66	35.94	29.08	26.54	21.49	19.61	15.87	14.49	10.70
261			50	80	2.0	Extrusions	Weibull Normal	X <sub>0</sub>	41.14	30.39	24.59	22.44	17.98	16.50	13.26	12.15	8.923	
									σ	7.743*	6.515*	5.775	5.482	4.859	4.613	4.088	3.881	3.266*
									n	48.19	40.55	35.94	34.12	30.24	28.71	25.44	24.16	20.32
262			20	80	1.0	Extrusions	Weibull Normal	n	6.515*	40.55	35.94	34.12	30.24	28.71	25.44	24.16	20.32	
									b	1.509*	1.507*	1.578	1.578	1.471	1.425	1.475	1.443	1.497*
									θ	50.37	34.95	27.06	24.23	18.73	16.77	12.99	11.63	8.068
263			20	80	2.0	Extrusions	Weibull Normal	X <sub>0</sub>	33.84	23.26	17.99	16.11	12.65	11.40	8.771	7.887	5.430	
									σ	7.743*	6.515*	5.775	5.482	4.859	4.613	4.088	3.881	3.266*
									n	48.19	40.55	35.94	34.12	30.24	28.71	25.44	24.16	20.32

Mechanical and Electropolishing



S<sub>y</sub> = 78 ksi  
S<sub>u</sub> = 76 ksi

7075 ALCLAD ALUMINIUM

Composition: See Page 167.  
(\* ) Extrapolated Values

Code No.	TEST CONDITIONS				FATIGUE STRENGTH DISTRIBUTIONS AND THEIR PARAMETERS												
	Heat Treat	Surf. Fin.	Freq.	Temp °F	K <sub>t</sub>	Other	DIST.	Param.	LIFE IN CYCLES								
									1x10 <sup>3</sup>	1x10 <sup>4</sup>	5x10 <sup>4</sup>	1x10 <sup>5</sup>	5x10 <sup>5</sup>	1x10 <sup>6</sup>	5x10 <sup>6</sup>	1x10 <sup>7</sup>	1x10 <sup>8</sup>

PLATE BENDING (Completely Reversed)

Miscellaneous

264	T-6	Hot Rolled	Wetball	b	1.909*	1.750*	1.977*	1.945	1.879	1.853	1.845	1.845	1.845	1.845	1.845	1.845	1.845*
					43.48	33.67	28.19	26.11	21.84	20.22	16.92	15.67	12.14				
					35.88	28.04	23.17	21.49	18.05	16.74	14.01	12.98	10.05				

AXIAL (Completely Reversed)

Miscellaneous

265	T-6	Cold Rolled	L.E.V.	M	.2339*	.3744	.5202	.5994	.8328	.9586	1.333*	1.536*	2.459*
					70.71	44.17	31.79	27.59	19.86	17.23	12.40	10.76	6.726
266	T-6	Milled Edges	Wetball	q	3.986*	3.695	3.886	3.839	3.829*	3.829*	2.829*	3.829*	3.829*
					41.72	26.89	19.79	17.34	12.76	11.18	8.230	7.211	4.650
					32.15	21.08	15.34	13.48	9.928	8.700	6.402	5.609	3.617

S<sub>y</sub> = 81 ksi  
 S<sub>u</sub> = 64 ksi

7076 ALUMINUM

Composition: See Page 167  
 (\*) Extrapolated Values

Code No.	TEST CONDITIONS				FATIGUE STRENGTH DISTRIBUTIONS AND THEIR PARAMETERS											
	Heat Treat	Surf. Fin.	Freq.	Temp	K <sub>t</sub>	Other	DIST.	Param.	LIFE IN CYCLES							
									1x10 <sup>3</sup>	1x10 <sup>4</sup>	5x10 <sup>4</sup>	1x10 <sup>5</sup>	5x10 <sup>5</sup>	1x10 <sup>6</sup>	5x10 <sup>6</sup>	1x10 <sup>7</sup>

ROTARY BEAM BENDING  
 Effect of Frequency

Code No.	Heat Treat	Surf. Fin.	Freq.	Temp	K <sub>t</sub>	Other	DIST.	Param.	1x10 <sup>3</sup>	1x10 <sup>4</sup>	5x10 <sup>4</sup>	1x10 <sup>5</sup>	5x10 <sup>5</sup>	1x10 <sup>6</sup>	5x10 <sup>6</sup>	1x10 <sup>7</sup>	1x10 <sup>8</sup>
267	HT-9	Mechanical Polish 1 RMS	100	80	1.0	Forged and Swaged	S.E.V.	σ	.4940* 61.21	.6051* 49.97	.6972* 43.37	.7411* 40.80	.8540 35.41	.9077 33.31	1.045 28.91	1.111 27.20	1.361* 22.21
268	HT-9	Mechanical Polish 1 RMS	167	80	1.0	Forged and Swaged	S.E.V.	σ	.5746* 42.86	.6522* 37.76	.7126* 34.56	.7403* 33.27	.8088* 30.45	.8403 29.31	.9181 26.83	.9538 25.82	1.082* 22.75
269	HT-9	Mechanical Polish 1 RMS	200	80	1.0	Forged and Swaged	Wetbull	σ <sub>q</sub>	2.810* 41.45 35.29	2.759* 37.67 32.14	2.726* 35.24 30.10	2.712* 34.24 29.26	2.682* 32.02 27.41	2.681 31.11 26.63	2.681 29.10 24.91	2.681 28.28 24.20	2.681* 25.70 22.00

Miscellaneous

Code No.	Heat Treat	Surf. Fin.	Freq.	Temp	K <sub>t</sub>	Other	DIST.	Param.	1x10 <sup>3</sup>	1x10 <sup>4</sup>	5x10 <sup>4</sup>	1x10 <sup>5</sup>	5x10 <sup>5</sup>	1x10 <sup>6</sup>	5x10 <sup>6</sup>	1x10 <sup>7</sup>	1x10 <sup>8</sup>
270			167	80	1.0	Forged and Swaged	Wetbull	σ <sub>q</sub>	2.468* 67.52 58.09	2.283 51.78 44.88	2.336 43.03 37.21	2.249 39.72 34.47	2.499 33.01 28.36	2.329 30.47 26.36	2.386 25.32 21.85	2.503* 23.38 20.08	2.321* 17.93 15.51
271	HT-9	M.P. 1 RMS	100	80	3.4	Forged and Swaged	L.R.V. Wetbull	σ	.1809* 23.44	.2181* 19.44	.2486* 17.06	.2630* 16.13	.2997 14.15	.3170 13.38	.3613 11.74	.3822 11.10	.4608* 9.208

HT-9: Aged 560°F, 10 hrs, W.Q., Aged 275°F, 12 hrs, A.C.

S<sub>y</sub> = 81 ksi  
S<sub>u</sub> = 64 ksi

7076 ALUMINUM (Cont'd)

Composition: See Page 167  
(\* Extrapolated Values)

Code No.	TEST CONDITIONS				FATIGUE STRENGTH DISTRIBUTIONS AND THEIR PARAMETERS												
	Heat Treat	Surt. Min.	Freq.	Temp	K <sub>t</sub>	Other	DIST.	Param.	LIFE IN CYCLES								
									1x10 <sup>3</sup>	1x10 <sup>4</sup>	5x10 <sup>4</sup>	1x10 <sup>5</sup>	5x10 <sup>5</sup>	1x10 <sup>6</sup>	5x10 <sup>6</sup>	1x10 <sup>7</sup>	1x10 <sup>8</sup>

PLATE BENDING (Completely Reversed)  
Miscellaneous

Code No.	Heat Treat	Surt. Min.	M.P.	As Is	Temp	K <sub>t</sub>	Other	DIST.	Param.	LIFE IN CYCLES								
										1x10 <sup>3</sup>	1x10 <sup>4</sup>	5x10 <sup>4</sup>	1x10 <sup>5</sup>	5x10 <sup>5</sup>	1x10 <sup>6</sup>	5x10 <sup>6</sup>	1x10 <sup>7</sup>	1x10 <sup>8</sup>
272	HT-9				25	1.0				1.763*	1.797*	1.818*	1.826*	1.707	1.712	1.712	1.712	1.712*
					80					45.48	38.37	34.07	32.37	28.70	27.26	24.20	22.99	19.39
										31.24	26.23	23.22	22.04	19.87	18.86	16.75	15.91	13.42
273	HT-9				29	2.2				3.354*	3.051*	2.855*	2.775*	2.597	2.524	2.362	2.296	2.088*
					80					25.62	23.31	21.81	21.20	19.84	19.28	18.05	17.54	15.96

S<sub>y</sub> = 61 ksi  
S<sub>u</sub> = 55 ksi

7106 ALUMINUM

Composition: See Page  
(\* Extrapolated Values)

AXIAL (Completely Reversed)  
Miscellaneous

Code No.	Heat Treat	Surt. Min.	M.P.	As Is	Temp	K <sub>t</sub>	Other	DIST.	Param.	LIFE IN CYCLES								
										1x10 <sup>3</sup>	1x10 <sup>4</sup>	5x10 <sup>4</sup>	1x10 <sup>5</sup>	5x10 <sup>5</sup>	1x10 <sup>6</sup>	5x10 <sup>6</sup>	1x10 <sup>7</sup>	1x10 <sup>8</sup>
274	T-6					1.0				3.820*	2.353	1.677	1.449	1.032	.8927*	.6362*	.5498*	.3386*
					80					56.87	35.04	24.96	21.57	15.37	13.28	9.470	8.184	5.041

Composition: See Page 167  
 (\*) Extrapolated Values

7079 ALUMINUM

S<sub>u</sub> = 70-79 ksi  
 S<sub>y</sub> = 63-66 ksi

Code No.	TEST CONDITIONS				FATIGUE STRENGTH DISTRIBUTIONS AND THEIR PARAMETERS													
	Heat Treat	Surt. Fin.	Freq.	Temp.	K <sub>t</sub>	Other	DIST.	Param.	LIFE IN CYCLES								1x10 <sup>7</sup>	1x10 <sup>8</sup>
									1x10 <sup>3</sup>	1x10 <sup>4</sup>	5x10 <sup>4</sup>	1x10 <sup>5</sup>	5x10 <sup>5</sup>	1x10 <sup>6</sup>	5x10 <sup>6</sup>	1x10 <sup>7</sup>		
275	T-6			80	1.0	Longitudinal	L.E.V.	M	.3172*	.3698*	.4117*	.4312*	.4800	.5027	.5597	.5861	.6834*	
						Longitudinal	L.E.V.	M	51.12	43.84	39.38	37.60	33.77	32.25	28.97	27.66	23.72	
276	T-6			80	1.0	Longitudinal	S.F.V.	M	.3824*	.4455*	.4958*	.5191	.5776	.6048	.6730	.7046	.8210*	
						Longitudinal	S.F.V.	M	51.86	44.51	40.00	38.20	34.33	32.79	29.47	28.14	24.16	
277	T-6			80	1.0	Short	L.E.V.	M	.2804*	.3167*	.3448*	.3576	.3893	.4038	.4397	.4561	.5150	
						Short	L.E.V.	M	40.16	35.56	32.66	31.49	28.92	27.88	25.61	24.69	21.86	
278	T-6			80		Longitudinal	Wetbulb	0	1.637*	1.821*	1.711*	1.669	1.637	1.637	1.637*	1.857*	1.857*	
						Longitudinal	Wetbulb	0	34.33	25.99	21.37	19.65	16.17	14.86	12.23	11.25	8.514	
						Longitudinal	Wetbulb	0	30.95	23.24	19.21	17.69	14.57	13.40	11.02	10.05	7.604	
279	T-6			80	Notched	Long	Wetbulb	0	.9525*	.9525*	.9525*	.9525*	.9525	.9525	.9153	.8435	.9286*	
					Notched	Long	Wetbulb	0	31.89	25.66	22.04	20.64	17.73	16.61	14.26	13.34	10.75	
					Notched	Long	Wetbulb	0	27.60	22.20	19.07	17.86	15.34	14.37	12.37	11.64	9.320	
280	T-6			80		Short	Wetbulb	0	1.053*	.8126*	.8709*	.8721	.7569	1.042	.9394	.8936	1.065*	
						Short	Wetbulb	0	24.91	21.08	18.84	17.94	15.99	15.31	13.64	12.98	11.07	
						Short	Wetbulb	0	21.26	18.31	16.30	15.53	13.93	13.08	11.75	11.21	9.446	

ROTARY BEAM BENDING  
 Effect of Direction of Loading

Composition: See Page 167  
(\* Extrapolated Values)

7079 ALUMINUM (Cont'd)

S<sub>y</sub> = 70-71 ksi  
S<sub>u</sub> = 63-66 ksi

Code No.	TEST CONDITIONS				FATIGUE STRENGTH DISTRIBUTIONS AND THEIR PARAMETERS											
	Heat Treat	Surf. Fin.	Freq.	Temp °F	K <sub>t</sub>	Other	DIST.	Param.	LIFE IN CYCLES							
									1x10 <sup>3</sup>	1x10 <sup>4</sup>	5x10 <sup>4</sup>	1x10 <sup>5</sup>	5x10 <sup>5</sup>	1x10 <sup>6</sup>	5x10 <sup>6</sup>	1x10 <sup>7</sup>

ROTARY BEAM BENDING

Effect of Stress Concentration

Code No.	Heat Treat	Surf. Fin.	Freq.	Temp °F	K <sub>t</sub>	Other	DIST.	Param.	LIFE IN CYCLES								
									1x10 <sup>3</sup>	1x10 <sup>4</sup>	5x10 <sup>4</sup>	1x10 <sup>5</sup>	5x10 <sup>5</sup>	1x10 <sup>6</sup>	5x10 <sup>6</sup>	1x10 <sup>7</sup>	1x10 <sup>8</sup>
281	T-6			80	1.0	Longitudinal	L.E.V.	M	.3172*	.3698*	.4117*	.4312*	.4800	.5027	.5597	.5861	.6834*
									51.12	43.84	39.38	37.60	33.77	32.25	28.97	27.66	23.72
282	T-6			80	Notch	Longitudinal	Webull L.E.V.	X <sub>o</sub>	1.637*	1.821*	1.711*	1.669	1.637	1.637	1.637*	1.857*	1.857*
									34.33	25.99	21.37	19.65	16.17	14.86	12.23	11.25	8.514
283	T-6			80	1.0	Longitudinal	S.E.V.	M	.3824*	.4455*	.4958*	.5191	.5776	.6048	.6730	.7046	.8210*
									51.86	44.51	40.00	38.20	34.33	32.79	29.47	28.14	24.16
284	T-6			80	Notch	Longitudinal	Webull	X <sub>o</sub>	.9525*	.9525*	.9525*	.9525*	.9525	.9525	.9153	.8435	.9286*
									31.89	25.66	22.04	20.64	17.73	16.61	14.26	13.34	10.75
285	T-6			80	1.0	Longitudinal	L.E.V.	M	.2804*	.3167*	.3448*	.3576	.3893	.4038	.4397	.4561	.5150
									40.16	35.56	32.66	31.49	28.92	27.88	25.61	24.69	21.86
286	T-6			80	Notch	Short Transverse	Webull	X <sub>o</sub>	1.053*	.8126*	.8709*	.8721	.7569	1.042	.9394	.8936	1.065*
									24.91	21.08	18.84	17.94	15.99	15.31	13.64	12.98	11.07
286	T-6			80	Notch	Short Transverse	Webull	X <sub>o</sub>	21.26	18.31	16.30	15.53	13.93	13.08	11.75	11.21	9.446
									21.26	18.31	16.30	15.53	13.93	13.08	11.75	11.21	9.446

Composition: See Page 167  
 (\*) Extrapolated Values

7079 ALUMINUM (Cont'd)

S<sub>y</sub> = 70-79 ksi  
 S<sub>u</sub> = 63-66 ksi

+Code No.	TEST CONDITIONS				FATIGUE STRENGTH DISTRIBUTIONS AND THEIR PARAMETERS												
	Heat Treat	Surf. Fin.	Freq.	Temp	R <sub>t</sub>	Other	DIST.	Param.	LIFE IN CYCLES								
									1x10 <sup>3</sup>	1x10 <sup>4</sup>	5x10 <sup>4</sup>	1x10 <sup>5</sup>	5x10 <sup>5</sup>	1x10 <sup>6</sup>	5x10 <sup>6</sup>	1x10 <sup>7</sup>	1x10 <sup>8</sup>

ROTARY BEAM BENDING  
 Miscellaneous

287	T-6			80	1.0				.2739* 42.36	.3010* 38.54	.3216 36.08	.3308 35.07	.3534 32.83	.3636 31.91	.3884 29.87	.3996 29.04	.4391* 26.42
288	T-652	M.P. 16 RMS		80	1.0	Forged	Webull S.F.V.	σ <sub>x</sub> θ <sub>y</sub>	3.113* 63.26 44.73	3.040 48.75 34.71	3.059 40.63 28.88	3.218 37.58 26.30	3.130 31.32 22.11	3.096 28.96 20.51	3.230 24.14 16.87	3.204* 22.32 15.64	3.132* 17.20 12.14

AXIAL (Completely Reversed)  
 Miscellaneous

289	T-6	M.P. 10 RMS		80	1.0	Drawn	Webull Normal	σ <sub>x</sub> θ <sub>y</sub>	6.466* 43.50	5.555 37.37	4.995 33.60	4.772 32.10	4.291 28.87	4.099 27.58	3.686 24.80	3.521 23.69	3.025* 20.35
290	T-652	M.P. 8 RMS		80	1.0	Forged	Webull	σ <sub>x</sub> θ <sub>y</sub>	4.665 45.70 25.09	4.502 31.10 17.47	4.355 26.35 15.11	4.065 17.93 10.69	3.999* 15.19 9.139	3.882* 10.34 6.314	3.844* 8.764 5.376	3.806* 5.055 3.116	

7178 ALUMINUM  
 Composition: See Page 167  
 (\*) Extrapolated Values

S<sub>u</sub> = 88 ksi  
 S<sub>y</sub> = 78 ksi

+Code No.	TEST CONDITIONS				FATIGUE STRENGTH DISTRIBUTIONS AND THEIR PARAMETERS												
	Heat Treat	Surf. Fin.	Freq.	Temp	r	Other	DIST.	Param.	LIFE IN CYCLES								
									1x10 <sup>3</sup>	1x10 <sup>4</sup>	5x10 <sup>4</sup>	1x10 <sup>5</sup>	5x10 <sup>5</sup>	1x10 <sup>6</sup>	5x10 <sup>6</sup>	1x10 <sup>7</sup>	1x10 <sup>8</sup>

ROTARY BEAM BENDING  
 Effect of Grain Direction

+Code No.	Heat Treat	Surf. Fin.	Freq.	Temp	r	Other	DIST.	Param.	1x10 <sup>3</sup>	1x10 <sup>4</sup>	5x10 <sup>4</sup>	1x10 <sup>5</sup>	5x10 <sup>5</sup>	1x10 <sup>6</sup>	5x10 <sup>6</sup>	1x10 <sup>7</sup>	1x10 <sup>8</sup>
291	I-6			80	1.0	Longitudinal	Longitudinal	β	.2237* 84.07	.2840* 66.22	.3355 56.05	.3605 52.16	.4260 44.15	.4577 41.08	.5408 34.77	.5811 32.36	.7378 25.49
292	I-6			80	1.0	Longitudinal	Longitudinal	α β		6.116* 69.68	5.738 59.35	6.116 55.39	6.013 47.18	5.919 44.03	5.864 37.51	5.978 35.01	5.684 27.83
293	I-6			80	Notched	Longitudinal	Longitudinal	β	.1465* 39.74	.1901* 30.62	.2281 25.52	.2467 23.60	.2960 19.67	.3202 18.18	.3842 15.15	.4155 14.01	.5393 10.79
294	I-6			80	Notched	Transverse	Transverse	α β	3.177* 37.78	3.067* 29.22	3.220 24.42	3.197 22.61	3.149 18.89	3.131 17.48	3.121 14.61	3.121 13.52	3.121* 10.46

Composition: See Page 167  
 (\*) Extrapolated Values

7178 ALUMINUM (Cont'd)

S<sub>u</sub> = 88 ksi  
 S<sub>y</sub> = 78 ksi

Code No.	TEST CONDITIONS				FATIGUE STRENGTH DISTRIBUTIONS AND THEIR PARAMETERS													
	Heat Treat	Surt.	Pln.	Freq.	Temp °F	R <sub>r</sub>	Other	DIST.	Param.	LIFE IN CYCLES								
										1x10 <sup>3</sup>	1x10 <sup>4</sup>	5x10 <sup>4</sup>	1x10 <sup>5</sup>	5x10 <sup>5</sup>	1x10 <sup>6</sup>	5x10 <sup>6</sup>	1x10 <sup>7</sup>	1x10 <sup>8</sup>

ROTARY BEAM BENDING  
 Effect of Stress Concentration

Code No.	Heat Treat	Surt.	Pln.	Freq.	Temp °F	R <sub>r</sub>	Other	DIST.	Param.	LIFE IN CYCLES								
										1x10 <sup>3</sup>	1x10 <sup>4</sup>	5x10 <sup>4</sup>	1x10 <sup>5</sup>	5x10 <sup>5</sup>	1x10 <sup>6</sup>	5x10 <sup>6</sup>	1x10 <sup>7</sup>	1x10 <sup>8</sup>
295	I-6				80	1.0	Longitudinal	S.E.V.	M β	.2237*	.2840*	.3355	.3605	.4260	.4577	.5408	.5811	.7378
										84.07	66.22	56.05	52.16	44.15	41.08	34.77	32.36	25.49
296	I-6				80	Notch	Longitudinal	L.E.V.	M β	.1465*	.1901*	.2281	.2467	.2960	.3202	.3842	.4155	.5393
										39.74	30.62	25.52	23.60	19.67	18.18	15.15	14.01	10.79
297	I-6				80	1.0	Transverse	Webull	σ <sub>x</sub> σ <sub>y</sub> q	6.116*	5.738	6.116	6.013	6.013	5.919	5.864	5.978	5.684
										69.68	59.35	55.39	47.18	44.03	37.51	35.01	27.83	
298	I-6				80	Notch	Transverse	Webull	σ <sub>x</sub> σ <sub>y</sub> q	50.06	43.53	39.80	34.09	31.98	27.32	25.34	20.47	
										3.177*	3.067*	3.220	3.197	3.149	3.131	3.121	3.121	3.121*
										37.78	29.22	24.42	18.89	17.48	14.61	13.52	10.46	
										27.22	21.26	17.53	13.64	12.65	10.58	9.796	7.578	



A-1.5.2 Cobalt Alloys

S<sub>u</sub> = 123 ksi  
S<sub>y</sub> = 65 ksi

STELLITE - 31

Composition: See Page 167  
(\* Extrapolated Values)

Code No.	TEST CONDITIONS				FATIGUE STRENGTH DISTRIBUTIONS AND THEIR PARAMETERS												
	Heat Treat	Surf. Fin.	Freq.	Temp	R <sub>r</sub>	Other	DIST.	Parab.	LIFE IN CYCLES								
									1x10 <sup>3</sup>	1x10 <sup>4</sup>	5x10 <sup>4</sup>	1x10 <sup>5</sup>	5x10 <sup>5</sup>	1x10 <sup>6</sup>	5x10 <sup>6</sup>	1x10 <sup>7</sup>	1x10 <sup>8</sup>

ROTARY BEAM BENDING  
Effect of Test Temperature

Code No.	Heat Treat	Surf. Fin.	Freq.	Temp	R <sub>r</sub>	Other	DIST.	Parab.	σ <sub>u</sub>	σ <sub>y</sub>	σ <sub>e</sub>	σ <sub>o</sub>	σ <sub>o</sub>	σ <sub>o</sub>	σ <sub>o</sub>	σ <sub>o</sub>	σ <sub>o</sub>
299	1400° F, 16 hrs., AC	Cast		1200	1.0		S.E.V.		.1827*	.2256	.2615	.2787	.3229*	.3441*	.3988*	.4250*	.5248*
300				1350	1.0		Wetbull		77.80	63.00	54.36	51.01	44.02	41.31	35.64	33.45	27.08
301		Mechanical Polish		1500	1.0		Wetbull		1.052*	.7867	1.439	.7676*	.9330*	.8038*	1.335*	1.250*	.9850*
									68.56	53.68	45.44	42.09	35.55	33.01	27.93	25.95	20.32
									65.19	51.37	42.73	40.30	33.90	31.58	26.35	24.54	19.36
									1.642*	1.492	1.478	1.394*	1.507*	1.456*	1.642*	1.642*	1.642*
									72.94	45.33	32.53	28.18	20.24	17.54	12.60	10.92	6.797
									61.44	38.62	27.74	24.17	17.22	14.98	10.61	9.202	5.725

AXIAL (Completely Reversed)  
Effect of Stress Concentration

Code No.	Heat Treat	Surf. Fin.	Freq.	Temp	R <sub>r</sub>	Other	DIST.	Parab.	σ <sub>u</sub>	σ <sub>y</sub>	σ <sub>e</sub>	σ <sub>o</sub>	σ <sub>o</sub>	σ <sub>o</sub>	σ <sub>o</sub>	σ <sub>o</sub>	σ <sub>o</sub>
302	1300° F, 50 hrs., AC	Cast		80	1.0		Normal		5.843*	5.122	4.671	4.489	4.095	3.935	3.589	3.450	3.024*
									75.81	66.45	60.61	58.25	53.13	51.06	46.57	44.76	39.24
303				80	2.4		Normal		7.838*	6.101*	5.120*	4.748*	3.985	3.696	3.102	2.877	2.239*
									65.24	50.78	42.62	39.53	33.17	30.76	25.82	23.94	18.64
304				80	3.4		Wetbull		1.037*	1.048*	1.055*	1.057*	1.064	1.067	1.073	1.076*	1.084*
									31.85	30.84	30.15	29.86	29.19	28.91	28.26	27.99	27.10
									26.44	25.57	24.99	24.74	24.17	23.93	23.38	23.15	22.39

S<sub>y</sub> = 123 ksi  
S<sub>u</sub> = 65 ksi

STELLITE - 31 (Cont'd)

Composition: See Page 167  
(\* Extrapolated Values)

Code No.	TEST CONDITIONS				FATIGUE STRENGTH DISTRIBUTIONS AND THEIR PARAMETERS													
	Heat Treat	Surf. Fin.	Freq.	Temp	M	r	Other	DIST.	Form	LIFE IN CYCLES								
										1x10 <sup>3</sup>	1x10 <sup>4</sup>	5x10 <sup>4</sup>	1x10 <sup>5</sup>	5x10 <sup>5</sup>	1x10 <sup>6</sup>	5x10 <sup>6</sup>	1x10 <sup>7</sup>	1x10 <sup>8</sup>

AXIAL (Completely Reversed)  
Effect of Stress Concentration

Code No.	Heat Treat	Surf. Fin.	Freq.	Temp	M	r	Other	DIST.	Form	1x10 <sup>3</sup>	1x10 <sup>4</sup>	5x10 <sup>4</sup>	1x10 <sup>5</sup>	5x10 <sup>5</sup>	1x10 <sup>6</sup>	5x10 <sup>6</sup>	1x10 <sup>7</sup>	1x10 <sup>8</sup>
305	1300 °F, 50 hrs., AC, Cast	M.P. Ground 10 RMS	60	1200	1.0			Webull	β	2.668* 45.61 39.86	2.668* 44.21 38.64	2.668* 43.26 37.81	2.668* 42.86 37.46	2.668* 41.94 36.65	2.668* 41.55 36.31	2.668* 40.66 35.53	2.668* 40.28 35.20	2.640* 39.05 34.16
306		Ground 10 RMS	60	1200	3.4			L.F.V.	β	.5549* 29.13	.5984* 27.01	.6308* 25.62	.6453* 25.04	.6803 23.76	.6959* 23.22	.7336* 22.03	.7505* 21.54	.8093* 19.97
307		M.P. Ground 10 RMS	60	1500	1.0			S.E.V.	β	.9139* 37.09	.9582* 35.37	.9905 34.22	1.004 33.73	1.038 32.63	1.053 32.17	1.089 31.12	1.104* 30.68	1.158* 29.26
308		Ground - 10 RMS	60	1500	2.4			Webull	β	.9818* 31.80 29.84	1.406* 28.84 26.70	1.344* 26.89 24.94	1.302 26.09 24.23	1.205 24.31 22.66	1.164 23.59 22.02	1.065 21.98 20.58	1.022 21.33 19.99	.8630* 19.28 18.15
309		Ground - 10 RMS	60	1500	3.4			Webull	β	4.108* 26.71 19.93	3.791* 24.98 19.06	4.065 23.85 17.85	3.767 23.37 17.86	4.042 22.31 16.73	4.035* 21.87 16.40	4.020* 20.88 15.67	4.014* 20.46 15.37	3.704* 19.14 14.69

Composition: See Page 167  
 (\*) Extrapolated Values

STELLITE - 31 (Cont'd)

S<sub>u</sub> = 123 ksi  
 S<sub>y</sub> = 65 ksi

Code No.	TEST CONDITIONS				Other	DIST.	PARAM.	LIFE IN CYCLES							
	Heat Treat	Surf. Fin.	Freq.	Temp				K <sub>t</sub>	1x10 <sup>3</sup>	1x10 <sup>4</sup>	5x10 <sup>4</sup>	1x10 <sup>5</sup>	5x10 <sup>5</sup>	1x10 <sup>6</sup>	5x10 <sup>6</sup>

AXIAL (Completely Reversed)  
 Effect of Test Temperature

Code No.	Heat Treat	Surf. Fin.	Freq.	Temp	K <sub>t</sub>	Other	DIST.	PARAM.	1x10 <sup>3</sup>	1x10 <sup>4</sup>	5x10 <sup>4</sup>	1x10 <sup>5</sup>	5x10 <sup>5</sup>	1x10 <sup>6</sup>	5x10 <sup>6</sup>	1x10 <sup>7</sup>	1x10 <sup>8</sup>
310	1300°F, 50 hrs., AC, Cast	M.P. 10 RMS	60	80	1.0		Normal	n	5.843*	5.122	4.671	4.489	4.095	3.935	3.589	3.450	3.024*
									75.81	66.45	60.61	58.25	53.13	51.06	46.57	44.76	39.24
311			50	1200	1.0		Wetbull	q	2.668*	2.668*	2.668	2.668	2.668	2.668	2.668*	2.668*	2.640*
									45.61	44.21	43.26	42.86	41.94	41.55	40.66	40.28	39.05
									39.86	38.64	37.81	37.46	36.65	36.31	35.53	35.20	34.16
312			60	1500	1.0		S.E.V.	β	.9139*	.9582*	.9905	1.004	1.038	1.053	1.089	1.104*	1.158*
									37.09	35.37	34.22	33.73	32.63	32.17	31.12	30.68	29.26
313		Ground - 10 RMS	60	80	2.4		Normal	n	7.838*	6.101*	5.120*	4.748*	3.985	3.696	3.102	2.877	2.239*
									65.24	50.78	42.62	39.53	33.17	30.76	25.82	23.94	18.64
314			60	1500	2.4		Wetbull	q	.9818*	1.406*	1.344*	1.302	1.205	1.164	1.065	1.022	.8630*
									31.80	28.84	26.89	26.09	24.31	23.59	21.98	21.33	19.28
									29.84	26.70	24.94	24.23	22.66	22.02	20.58	19.99	18.15

S<sub>y</sub> = 123 ksi  
 S<sub>u</sub> = 65 ksi

STELLITE - 31 (Cont'd)

Composition: See Page 167  
 (\*) Extrapolated Values

Code No.	TEST CONDITIONS				FATIGUE STRENGTH DISTRIBUTIONS AND THEIR PARAMETERS												
	Heat Treat	Surf. Fin.	Freq.	Temp	R <sub>r</sub>	Other	DIST.	Param.	LIFE IN CYCLES								
									1x10 <sup>3</sup>	1x10 <sup>4</sup>	5x10 <sup>4</sup>	1x10 <sup>5</sup>	5x10 <sup>5</sup>	1x10 <sup>6</sup>	5x10 <sup>6</sup>	1x10 <sup>7</sup>	1x10 <sup>8</sup>

AXIAL (Completely Reversed)  
 Effect of Test Temperature

Code No.	1300°F, 50 hrs., AC <sub>3</sub>		1500		1200		80		3.4		Cast																	
	Surf. Fin.	Freq.	Surf. Fin.	Freq.	Surf. Fin.	Freq.	Surf. Fin.	Freq.	Surf. Fin.	Freq.	Wetbull	L.E.V.	M B	σ <sub>q</sub>	σ <sub>q</sub>	1.037*	1.048*	1.055*	1.057*	1.064	1.067	1.073	1.076*	1.084*				
315		60		60		60		60		60	31.85	30.84	30.15	29.86	29.19	28.91	28.26	27.99	27.10	26.44	25.57	24.99	24.74	24.17	23.93	23.38	23.15	22.39
316		60		60		60		60		60	.5549*	.5984*	.6308*	.6453*	.6803	.6959*	.7336*	.7505*	.8093*	29.13	27.01	25.62	25.04	23.76	23.22	22.03	21.54	19.97
317		60		60		60		60		60	4.108*	3.791*	4.065	3.767	4.042	4.035*	4.020*	4.014*	3.704*	26.71	24.98	23.85	23.37	22.31	21.87	20.88	20.46	19.14



S-816 (Cont'd)

Composition: See Page 167  
(\* Extrapolated Values)

S<sub>u</sub> = 147-148 ksi  
S<sub>y</sub> = 74-76 ksi

Code No.	TEST CONDITIONS				FATIGUE STRENGTH DISTRIBUTIONS AND THEIR PARAMETERS										
	Heat Treat	Surt. Fin.	Temp. T <sub>red</sub>	K <sub>t</sub>	Other	DIST.	LIFE IN CYCLES								
							1x10 <sup>3</sup>	1x10 <sup>4</sup>	5x10 <sup>4</sup>	1x10 <sup>5</sup>	5x10 <sup>5</sup>	1x10 <sup>6</sup>	5x10 <sup>6</sup>	1x10 <sup>7</sup>	1x10 <sup>8</sup>

AXIAL (Completely Reversed)  
Effect of Stress Concentration

Code No.	Heat Treat	Surt. Fin.	Temp. T <sub>red</sub>	K <sub>t</sub>	Other	DIST.	LIFE IN CYCLES									
							1x10 <sup>3</sup>	1x10 <sup>4</sup>	5x10 <sup>4</sup>	1x10 <sup>5</sup>	5x10 <sup>5</sup>	1x10 <sup>6</sup>	5x10 <sup>6</sup>	1x10 <sup>7</sup>	1x10 <sup>8</sup>	
322	HT-10	Mechanical Polishing or Ground - 10 RMS	60	80	1.0	Hot Rolled	b	3.239*	3.524	3.425	3.384	3.292	3.252	3.166	3.568	3.456*
							σ	74.55	70.99	68.59	67.59	65.30	64.34	62.17	61.28	58.34
							X <sub>0</sub>	63.38	59.64	57.86	57.11	55.40	54.67	53.02	51.38	49.15
323	HT-10	Mechanical Polishing or Ground - 10 RMS	60	80	2.4	Hot Rolled	b	2.095*	2.003*	2.093*	2.026*	2.159	2.110	2.008	1.970	2.136*
							σ	100.2	75.12	61.41	56.29	46.02	42.19	34.47	31.59	23.68
							X <sub>0</sub>	83.22	62.73	50.96	46.93	38.01	34.97	28.77	26.44	19.59
324	HT-10	Mechanical Polishing or Ground - 10 RMS	60	1500	1.0	Hot Rolled	b	1.168*	1.081*	1.015	.9858	.9123	.8777	.7876	.7422	1.080*
							σ	42.63	41.46	40.65	40.31	39.53	39.19	38.43	38.10	37.14
							X <sub>0</sub>	41.17	40.12	39.39	39.09	38.38	38.08	37.40	37.10	35.94
325	HT-10	Mechanical Polishing or Ground - 10 RMS	60	1500	2.4	Hot Rolled	b	1.315*	.9385	.8534	.9587	1.044	1.073	1.132*	1.147*	.8574*
							σ	35.76	30.49	27.37	26.18	23.57	22.53	20.27	19.37	16.55
							X <sub>0</sub>	29.80	26.23	23.67	22.50	20.13	19.19	17.18	16.40	14.30
326	HT-10	Mechanical Polishing or Ground - 10 RMS	60	1650	1.0	Hot Rolled	b	.7158*	.8067*	.8770*	.9792*	.9884*	1.024	1.114	1.154	1.301*
							σ	46.68	41.42	38.10	36.75	33.80	32.61	29.99	28.93	25.67
							X <sub>0</sub>									
327	HT-10	Mechanical Polishing or Ground - 10 RMS	60	1650	3.4	Hot Rolled	b	1.110*	1.029*	.9697	.9431	1.465	1.469	1.433	1.418	1.366*
							σ	25.86	24.28	23.23	22.80	21.88	21.47	20.54	20.16	18.93
							X <sub>0</sub>	24.01	22.60	21.66	21.27	20.04	19.67	18.85	18.51	17.41

A-1.5.3 Copper Alloys



Composition: See Page 167  
 (\*) Extrapolated Values

PURE COPPER

$S_u = 32-36 \text{ ksi}$   
 $S_y = 7.5-13 \text{ ksi}$

+Code No.	TEST CONDITIONS				FATIGUE STRENGTH DISTRIBUTIONS AND THEIR PARAMETERS											
	Heat Treat	Surf. Fin.	Freq.	Temp °F	K <sub>t</sub>	Other	DISTR.	Param	LIFE IN CYCLES							
									1x10 <sup>3</sup>	1x10 <sup>4</sup>	5x10 <sup>4</sup>	1x10 <sup>5</sup>	5x10 <sup>5</sup>	1x10 <sup>6</sup>	5x10 <sup>6</sup>	1x10 <sup>7</sup>

PLATE BENDING (Completely Reversed)

Miscellaneous

328				80	1.0		Webull	θ	4.385*	4.446*	4.374	4.345	4.285	4.261	4.210	4.190*	4.132*
							Webull	θ	15.03	12.49	10.97	10.38	9.125	8.631	7.585	7.174	5.963
							Webull	θ	9.900	8.180	7.240	6.868	6.071	5.756	5.083	4.817	4.027
329				80	1.0	Cold Worked	L.E.V.	β	.4431	.5691	.6339*	.8142*	.9069*	1.164*	1.297*	1.856*	
							Webull	θ	35.78	27.86	25.01	19.47	17.48	13.61	12.22	8.544	

472

AXIAL (Completely Reversed)

Miscellaneous

330	Annealed			80	1.0		Webull	θ	1.659*	1.743*	1.743*	1.743*	1.743	1.743	1.743*	1.743*	1.743*
							Webull	θ	34.04	24.15	19.00	17.13	13.48	12.15	9.565	8.626	6.119
							Webull	θ	30.82	21.80	17.15	15.46	12.16	10.97	8.631	7.784	5.522

Effect of Stress Concentration

331	HT-14		1470	482	1.0		Webull	θ	8.378*	7.548*	7.095	7.579	7.242	7.769	7.671	7.634	8.169*
							Webull	θ	27.49	23.47	21.01	20.04	17.94	17.11	15.32	14.61	12.47
							Webull	θ	21.35	18.70	16.97	15.95	14.42	13.54	12.16	11.61	9.753
332	HT-14	No-N	1470	482	1.0		Webull	θ	4.248*	4.111*	4.357*	4.004	4.275	4.275	3.951	3.951	4.275
							Webull	θ	21.30	16.59	13.94	12.92	10.86	10.07	8.458	7.845	6.113
							Webull	θ	16.22	12.75	10.54	9.997	8.257	7.659	6.561	6.086	4.648

HT-14: Annealed at 752 °F, F.C.

Composition: See Page 167  
 (\*) Extrapolated Values

70-30 BRASS

S<sub>u</sub> = 42-55 ksi  
 S<sub>y</sub> = 8.7-23 ksi

Code No.	TEST CONDITIONS				FATIGUE STRENGTH DISTRIBUTIONS AND THEIR PARAMETERS												
	Heat Treat	Surf. Fin.	Freq.	Temp	K <sub>t</sub>	Other	DIST.	Param.	LIFE IN CYCLES								
									1x10 <sup>3</sup>	1x10 <sup>4</sup>	5x10 <sup>4</sup>	1x10 <sup>5</sup>	5x10 <sup>5</sup>	1x10 <sup>6</sup>	5x10 <sup>6</sup>	1x10 <sup>7</sup>	1x10 <sup>8</sup>

AXIAL (Completely Reversed)  
 Effect of Grain Size

Code No.	Heat Treat	Surf. Fin.	Freq.	Temp	K <sub>t</sub>	Other	DIST.	Param.	1x10 <sup>3</sup>	1x10 <sup>4</sup>	5x10 <sup>4</sup>	1x10 <sup>5</sup>	5x10 <sup>5</sup>	1x10 <sup>6</sup>	5x10 <sup>6</sup>	1x10 <sup>7</sup>	1x10 <sup>8</sup>
333	Cold Rolled and Annealed	Electropolished		80	1.0	.016mm grain	S.E.V.	M				1.062*	1.189*	1.248*	1.396	1.466*	1.722*
334				80	1.0	.022mm grain	Webull	q			9.184*	10.40*	9.184*	9.185	9.184	9.795	7.961*
335				80	1.0	.033mm grain	Webull	q				2.586*	2.586*	2.586*	2.586	2.586	2.586*
336	Extruded and Annealed			80	1.0	.04mm grain	S.E.V.	M			2.593*	2.709*	2.997	3.130	3.463	3.617	4.179*
337				80	1.0	.075mm grain	Webull	q				1.222*	1.637*	1.637*	1.637	1.439	1.637*
338				80	1.0	.33mm grain	Webull	q				1.575*	1.575*	1.575*	1.575	1.575	1.575*

Composition: See Page 167  
 (\*) Extrapolated Values

70-30 BRASS (Cont'd)

S<sub>y</sub> = 42-55 ksi  
 S<sub>u</sub> = 8.7-23 ksi

Code No.	TEST CONDITIONS				FATIGUE STRENGTH DISTRIBUTIONS AND THEIR PARAMETERS												
	Heat Treat	Surf. Fin.	Freq.	Temp.	K <sub>t</sub>	Other	DIST.	Param.	LIFE IN CYCLES								
									1x10 <sup>3</sup>	1x10 <sup>4</sup>	5x10 <sup>4</sup>	1x10 <sup>5</sup>	5x10 <sup>5</sup>	1x10 <sup>6</sup>	5x10 <sup>6</sup>	1x10 <sup>7</sup>	1x10 <sup>8</sup>

AXIAL (Completely Reversed)  
 Effect of Stress Concentration

Code No.	Heat Treat	Surf. Fin.	Freq.	Temp.	K <sub>t</sub>	Other	DIST.	Param.	1x10 <sup>3</sup>	1x10 <sup>4</sup>	5x10 <sup>4</sup>	1x10 <sup>5</sup>	5x10 <sup>5</sup>	1x10 <sup>6</sup>	5x10 <sup>6</sup>	1x10 <sup>7</sup>	1x10 <sup>8</sup>
339	Cold Rolled and Annealed			80	1.0	Grain Size .016 mm	S.E.V.	M β				1.062*	1.189*	1.248*	1.396	1.466*	1.722*
340				80	Sharp-N		S.E.V.	M β				1.267*	1.766*	2.038*	2.840	3.277*	5.269*
341				80	1.0	Grain Size = 0.033 mm	Webull	σ <sub>y</sub> φ				2.586*	2.586*	2.586*	2.586	2.586	2.586*
342	Extruded and Annealed			80	Sharp-N		S.E.V.	M β	1.418*			1.609*	2.155*	2.445	3.276	3.715*	5.645*
343		Electropolished		80	K <sub>t</sub> -1		S.E.V.	M β	22.53			19.86	14.83	13.07	9.760	8.605	5.663
344				80	K <sub>t</sub> -2		Webull	σ <sub>y</sub> φ				1.753*	1.984*	2.093*	2.368	2.498	2.981
												18.67	16.50	15.64	13.82	13.10	10.98
												2.149*	2.149*	2.149	2.149	2.149	2.149*
												17.67	14.76	13.66	11.41	10.56	8.167
												14.76	12.33	11.41	9.536	8.825	6.822

K<sub>t</sub>-1: Cracked, cracks .11-.14 mm deep

K<sub>t</sub>-2: Cracked, cracks .27-.34 mm deep

S<sub>u</sub> = 42-72 ksi  
 S<sub>y</sub> = 10-35 ksi

Cu-7.3 AL BRONZE

Composition: See Page 168  
 (\*) Extrapolated Values

Code No.	TEST CONDITIONS				Heat Treat	Surt. Fin.	Freq.	Temp. °F	K <sub>t</sub>	Other	DISTR.	Param.	FATIGUE STRENGTH DISTRIBUTIONS AND THEIR PARAMETERS							
	LIFE IN CYCLES																			
	1x10 <sup>3</sup>	1x10 <sup>4</sup>	5x10 <sup>4</sup>	1x10 <sup>5</sup>									5x10 <sup>5</sup>	1x10 <sup>6</sup>	5x10 <sup>6</sup>	1x10 <sup>7</sup>	1x10 <sup>8</sup>			

**CANTILEVER BEAM BENDING (Completely Reversed)**  
 Effect of Grain Size

Code No.	Heat Treat	Surt. Fin.	Freq.	Temp. °F	K <sub>t</sub>	Other	DISTR.	Param.	LIFE IN CYCLES							
									1x10 <sup>3</sup>	1x10 <sup>4</sup>	5x10 <sup>4</sup>	1x10 <sup>5</sup>	5x10 <sup>5</sup>	1x10 <sup>6</sup>	5x10 <sup>6</sup>	1x10 <sup>7</sup>
345				80	1.0	.2-.5 grain	Weibull	X <sub>θ</sub> q	1.004*	1.028	1.029	.9475	.8956	.7649*	.6983*	.9717*
									.8827*	22.69	20.05	16.75	15.86	13.97	13.23	11.13
346			80	1.0	.022mm grain	Weibull	X <sub>θ</sub> q	3.429*	3.481	3.256	3.611	3.456	3.558*	3.507*	3.360*	
								24.26	20.18	17.80	14.96	14.21	12.62	11.98	9.925	

S<sub>u</sub> = 60 ksi  
 S<sub>y</sub> = 19 ksi

5.6 AL BRONZE

Composition: See Page 168  
 (\*) Extrapolated Values

**CANTILEVER BEAM BENDING**  
 Miscellaneous

Code No.	Heat Treat	Surt. Fin.	Freq.	Temp. °F	K <sub>t</sub>	Other	DISTR.	Param.	LIFE IN CYCLES							
									1x10 <sup>3</sup>	1x10 <sup>4</sup>	5x10 <sup>4</sup>	1x10 <sup>5</sup>	5x10 <sup>5</sup>	1x10 <sup>6</sup>	5x10 <sup>6</sup>	1x10 <sup>7</sup>
347			80	1.0	.042mm grain	S.E.V.	M β	.798*	2.004	2.099	2.340	2.451	2.732*	2.862*	3.342*	
									2.004	29.84	28.48	25.56	24.39	20.89	17.89	

Composition: See Page 168  
 (\*) Extrapolated Values

Al-Ni BRONZE

S<sub>u</sub> = 116 ksi  
 S<sub>y</sub> = 85 ksi

Code No.	TEST CONDITIONS				FATIGUE STRENGTH DISTRIBUTIONS AND THEIR PARAMETERS												
	Heat Treat	Surf. Fin.	Freq.	Temp. °M	K <sub>r</sub>	Other	DIST.	Param.	LIFE IN CYCLES								
									1x10 <sup>3</sup>	1x10 <sup>4</sup>	5x10 <sup>4</sup>	1x10 <sup>5</sup>	5x10 <sup>5</sup>	1x10 <sup>6</sup>	5x10 <sup>6</sup>	1x10 <sup>7</sup>	1x10 <sup>8</sup>

ROTARY BEAM BENDING

Miscellaneous

348																		
		M.P.		80	1.0		Wetball	b θ q				2.037*	2.006*	1.978*	1.915	1.890	1.807*	
												66.26	60.55	58.24	53.22	51.19	45.00	
												58.68	53.68	51.69	47.33	45.57	40.16	

S<sub>u</sub> = 47 ksi  
 S<sub>y</sub> = 14 ksi

Composition: See Page 168  
 (\*) Extrapolated Values

PHOSPHOR BRONZE

PLATE BENDING (Completely Reversed)

Miscellaneous

349	1 hr. at 500°C			80	V-Not.		L.E.V.	M. β				.2364*	.3289*	.3633	.4576	.5054*	.7032*
												12.22	8.786	7.955	6.315	5.717	4.109
												.2611*	.3289*	.3633	.4576	.5054*	.7032*
												11.06	8.786	7.955	6.315	5.717	4.109

Composition: See Page 168  
 (\*) Extrapolated Values

MUNTZ METAL (BRASS)

S<sub>u</sub> = 48.5 ksi  
 S<sub>y</sub> = 13.3 ksi

+Code No.	TEST CONDITIONS				FATIGUE STRENGTH DISTRIBUTIONS AND THEIR PARAMETERS												
	Heat Treat	Surf. Fin.	Freq.	Temp °K	K <sub>t</sub>	Other	DISP.	Param.	LIFE IN CYCLES								
									1x10 <sup>3</sup>	1x10 <sup>4</sup>	5x10 <sup>4</sup>	1x10 <sup>5</sup>	5x10 <sup>5</sup>	1x10 <sup>6</sup>	5x10 <sup>6</sup>	1x10 <sup>7</sup>	1x10 <sup>8</sup>

PLATE BENDING (Completely Reversed)

Miscellaneous

350	1 hr. at 550°C			80	V-Not.		S.E.V.	M B				.4722*	.5726*	.6222*	.7546	.8200	1.080*
												12.94	10.67	9.820	8.098	7.452	5.655

S<sub>u</sub> = 76.6 ksi  
 S<sub>y</sub> = 32.8 ksi

Composition: See Page 168  
 (\*) Extrapolated Values

Cu-6.5 Al-2.4 Fe

CANTILEVER BEAM BENDING

Miscellaneous

351				80	1.0	.0075	mm gr.	S.E.V.	M B	.4006*	.4774*	.5397	.5689	.6431	.6780	.7664	.8080*	.9628*
										63.81	53.54	47.37	44.93	39.75	37.70	33.35	31.64	26.55

A-1.5.4 Magnesium Alloys

Composition: See Page 163  
 (\*) Extrapolated Values

2.5 A1 MAGNESIUM

+Code No.	TEST CONDITIONS				FATIGUE STRENGTH DISTRIBUTIONS AND THEIR PARAMETERS											
	Heat Treat	Surf. Fin.	Freq.	Temp °F	R <sub>t</sub>	Other	DISTR.	Param.	LIFE IN CYCLES							
									1x10 <sup>3</sup>	1x10 <sup>4</sup>	5x10 <sup>4</sup>	1x10 <sup>5</sup>	5x10 <sup>5</sup>	1x10 <sup>6</sup>	5x10 <sup>6</sup>	1x10 <sup>7</sup>

ROTARY BEAM BENDING

Effect of Stress Concentration

Code No.	Heat Treat	Surf. Fin.	Freq.	Temp °F	R <sub>t</sub>	Other	DISTR.	Param.	1x10 <sup>3</sup>	1x10 <sup>4</sup>	5x10 <sup>4</sup>	1x10 <sup>5</sup>	5x10 <sup>5</sup>	1x10 <sup>6</sup>	5x10 <sup>6</sup>	1x10 <sup>7</sup>	1x10 <sup>8</sup>	
352				80	1.0		Normal	n	2.273* 13.35	1.892* 11.11	1.664* 9.778	1.575 9.252	1.385 8.139	1.311 7.702	1.153 6.775	1.091 6.412	.9086* 5.337	
353				80	2.6		S.E.V.	β	.4714* 15.77	.7141* 10.41	.9546* 7.791	1.081* 6.875	1.446 5.143	1.638 4.539	2.190 3.395	2.482 2.996	3.760* 1.978	
354				80	2.8		S.E.V.	β	.3895* 22.79	.6559* 13.53	.9442* 9.403	1.104* 8.038	1.589 5.584	1.860 4.773	2.677 3.316	3.132 2.834	5.274* 1.683	
355				80	3.8		Normal	n	1.120* 7.760	.8964* 6.206	.7668* 5.309	.7170* 4.964	.6133 4.246	.5734 3.970	.4905 3.396	.4586 3.175	.3668* 2.540	
356				80	4.3		S.E.V.	β	.3786* 20.19	.6273* 12.18	.8930* 8.561	1.039* 7.354	1.479* 5.166	1.722 4.437	2.452 3.116	2.854 2.678	4.730* 1.616	
357				80	6.5		Wetbulb	β	2.364* 7.660	2.364* 5.918	2.364* 4.941	2.364* 4.572	2.364 3.818	2.364 3.532	2.364 2.949	2.364 2.729	2.364* 2.108	2.364* 1.521



S<sub>u</sub> = 37 ksi  
S<sub>y</sub> = 22 ksi

AZ31A MAGNESIUM

Composition: See Page 168  
(\* ) Extrapolated Values

Code No.	TEST CONDITIONS				Other	DISTR.	FATIGUE STRENGTH DISTRIBUTIONS AND THEIR PARAMETERS								
	Heat Treat	Surf. Fin.	Temp. Req.	R <sub>r</sub>			LIFE IN CYCLES								
							1x10 <sup>3</sup>	1x10 <sup>4</sup>	5x10 <sup>4</sup>	1x10 <sup>5</sup>	5x10 <sup>5</sup>	1x10 <sup>6</sup>	5x10 <sup>6</sup>	1x10 <sup>7</sup>	1x10 <sup>8</sup>

AXIAL (Completely Reversed)  
Miscellaneous

Code No.	Heat Treat	Surf. Fin.	Temp. Req.	R <sub>r</sub>	Other	DISTR.	Wetbulb	Wetbulb	Wetbulb	Wetbulb	Wetbulb	Wetbulb	Wetbulb	Wetbulb	Wetbulb
358	HT-15	M.P. & E.P.	80	1.0			5.977*	5.664*	6.037*	5.962	5.813	5.785	5.724	5.698*	6.181*
							19.25	17.53	16.42	15.96	14.95	14.53	13.61	13.23	12.05
							15.59	14.34	13.26	12.93	12.17	11.84	11.12	10.82	9.691

Composition: See Page 168  
(\* ) Extrapolated Values

AZ31B MAGNESIUM

ROTARY BEAM BENDING  
Effect of Environment

Code No.	Heat Treat	Surf. Fin.	Temp. Req.	R <sub>r</sub>	Other	DISTR.	Wetbulb	Wetbulb	Wetbulb	Wetbulb	Wetbulb	Wetbulb	Wetbulb	Wetbulb	Wetbulb
359	HT-15	Mechanical Polishing	80	1.0	In Air		5.116*	4.936*	4.851	4.818	4.749	4.722	4.665	4.643	4.578*
					Water		26.89	21.97	19.07	17.95	15.58	14.66	12.73	11.98	9.792
					In Sea		17.51	14.53	12.71	11.99	10.48	9.884	8.624	8.130	6.679
360	HT-15	Mechanical Polishing	80	1.0	In Air		1.427*	1.297	1.217*	1.103*	1.103*				
					Water		43.61	16.59	8.449	6.316	3.217				
					In Sea		37.19	14.27	7.301	5.486	2.794				

Composition: See Page 168  
(\* ) Extrapolated Values

HT-15: Stress relieved at 500°F, 15 min., A.C.

Composition: See Page 168  
 (\*) Extrapolated Values

AZ61A MAGNESIUM

S<sub>y</sub> = 45-46 ksi  
 S<sub>u</sub> = 29-34 ksi

Code No.	TEST CONDITIONS					FATIGUE STRENGTH DISTRIBUTIONS AND THEIR PARAMETERS										
	Heat Treat	Surt. Fln.	Freq.	Temp.	R <sub>r</sub>	Other	DIST.	LIFE IN CYCLES								
								1x10 <sup>3</sup>	1x10 <sup>4</sup>	5x10 <sup>4</sup>	1x10 <sup>5</sup>	5x10 <sup>5</sup>	1x10 <sup>6</sup>	5x10 <sup>6</sup>	1x10 <sup>7</sup>	1x10 <sup>8</sup>

ROTARY BEAM BENDING

Effect of Stress Concentration

Code No.	Heat Treat	Surt. Fln.	Freq.	Temp.	R <sub>r</sub>	Other	DIST.	LIFE IN CYCLES								
								1x10 <sup>3</sup>	1x10 <sup>4</sup>	5x10 <sup>4</sup>	1x10 <sup>5</sup>	5x10 <sup>5</sup>	1x10 <sup>6</sup>	5x10 <sup>6</sup>	1x10 <sup>7</sup>	1x10 <sup>8</sup>
361		M.P.	25	80	1.0		Webull	1.735*	1.832	1.789	1.718	1.832	1.818*	1.712*	1.832*	1.832*
								42.57	31.82	25.95	23.76	19.39	17.76	14.48	13.27	9.920
362		Ground	25	80	3.9		Webull	3.374*	3.374*	3.305	3.277	3.219	3.198	3.155	3.140	3.097*
								19.81	14.46	11.60	10.55	8.473	7.707	6.185	5.626	4.107
								8.915	6.509	5.317	4.871	3.966	3.626	2.941	2.685	1.980

PLATE BENDING (Completely Reversed)

Effect of Frequency

Code No.	Heat Treat	Surt. Fln.	Freq.	Temp.	R <sub>r</sub>	Other	DIST.	LIFE IN CYCLES								
								1x10 <sup>3</sup>	1x10 <sup>4</sup>	5x10 <sup>4</sup>	1x10 <sup>5</sup>	5x10 <sup>5</sup>	1x10 <sup>6</sup>	5x10 <sup>6</sup>	1x10 <sup>7</sup>	1x10 <sup>8</sup>
363		Mechanical Polishing	29	80	1.0		Normal	4.008*	3.395*	3.023*	2.876	2.561	2.436	2.169	2.063	1.747*
								23.11	19.57	17.43	16.58	14.76	14.04	12.50	11.89	10.07
364	HT-16		167	80	1.0		Webull	5.400*	5.400*	5.400	5.381	5.574	5.421	5.494	5.367	5.393*
								32.08	28.80	26.70	25.85	23.97	23.20	21.51	20.82	18.69
								24.28	21.80	20.21	19.59	17.98	17.54	16.21	15.79	14.15

AXIAL (Completely Reversed)

Miscellaneous

Code No.	Heat Treat	Surt. Fln.	Freq.	Temp.	R <sub>r</sub>	Other	DIST.	LIFE IN CYCLES								
								1x10 <sup>3</sup>	1x10 <sup>4</sup>	5x10 <sup>4</sup>	1x10 <sup>5</sup>	5x10 <sup>5</sup>	1x10 <sup>6</sup>	5x10 <sup>6</sup>	1x10 <sup>7</sup>	1x10 <sup>8</sup>
365	HT-16	M.P.	25	80	1.0		S.E.V.	.9297*	1.034	1.114	1.150	1.239	1.280	1.379	1.424	1.584*
								23.89	21.48	19.93	19.30	17.92	17.35	16.10	15.60	14.02

HT-16: Aged 750°F, 2 hr, AC, Stress Relieved, 600°F, 15 min., AC

Composition: See Page 168  
 (\*) Extrapolated Values

**AZ80A-F MAGNESIUM**

Code No.	TEST CONDITIONS				FATIGUE STRENGTH DISTRIBUTIONS AND THEIR PARAMETERS												
	Heat Treat	Surt. Fin.	Freq.	Temp °F	R <sub>r</sub>	Other	DIST.	Pattern	LIFE IN CYCLES								
									1x10 <sup>3</sup>	1x10 <sup>4</sup>	5x10 <sup>4</sup>	1x10 <sup>5</sup>	5x10 <sup>5</sup>	1x10 <sup>6</sup>	5x10 <sup>6</sup>	1x10 <sup>7</sup>	1x10 <sup>8</sup>

**ROTARY BEAM BENDING**

Miscellaneous

366	HT-17	M.P.		80	1.0	Extru-stress	S.F.V.	M β	.7349*	.8500*	.9410*	.9831	1.088	1.137	1.258*	1.315*	1.521*
									38.53	33.31	30.09	28.80	26.01	24.90	22.49	21.53	18.61

**AXIAL (Completely Reversed)**

Miscellaneous

367	HT-17	M.P.		80	1.0	Extru-stress	S.F.V.	M β	.4120*	.4538*	.4856*	.5000*	.5349*	.5508*	.5893	.6067	.6684*
									24.62	22.34	20.88	20.28	18.96	18.41	17.21	16.71	15.17

HT-17: Aged 750°F. 2 hrs. AC. Stress Relieved. 600°F. 15 min.

Composition: See Page 168  
 (\*) Extrapolated Values

AZ81 CAST MAGNESIUM

Code No.	TEST CONDITIONS				FATIGUE STRENGTH DISTRIBUTIONS AND THEIR PARAMETERS												
	Heat Treat	Surf. Fin.	Freq.	Temp	$K_f$	Other	DIST.	Param.	LIFE IN CYCLES								
									1x10 <sup>3</sup>	1x10 <sup>4</sup>	5x10 <sup>4</sup>	1x10 <sup>5</sup>	5x10 <sup>5</sup>	1x10 <sup>6</sup>	5x10 <sup>6</sup>	1x10 <sup>7</sup>	1x10 <sup>8</sup>

PLATE BENDING (Completely Reversed)  
 Effect of Shot Peening

Code No.	Heat Treat	Surf. Fin.	Freq.	Temp	$K_f$	Other	DIST.	Param.	1x10 <sup>3</sup>	1x10 <sup>4</sup>	5x10 <sup>4</sup>	1x10 <sup>5</sup>	5x10 <sup>5</sup>	1x10 <sup>6</sup>	5x10 <sup>6</sup>	1x10 <sup>7</sup>	1x10 <sup>8</sup>	
368	T-4			80	1.0	No Shot Peening	Weibull	X	1.071*	1.298*	1.262	1.078	1.139	1.103	1.021	.9858	.9037*	
									35.16	29.18	25.56	24.11	21.14	17.49	16.52	13.67		
									31.95	26.21	23.01	21.90	19.15	15.93	15.06	12.50		
369	T-4		80	1.0	45 psi Peening	Weibull	X		1.299*	1.262	1.311*	1.102	1.102	1.056	1.056*	1.056*	1.056*	1.056*
									23.67	21.02	15.93	14.14	10.74	9.537	6.429			
									22.21	19.72	15.05	13.38	10.15	9.022	6.081			

Composition: See Page 168  
 (\*) Extrapolated Values

HM21 MAGNESIUM

AXIAL (Completely Reversed)  
 Miscellaneous

Code No.	Heat Treat	Surf. Fin.	Freq.	Temp	$K_f$	Other	DIST.	Param.	1x10 <sup>3</sup>	1x10 <sup>4</sup>	5x10 <sup>4</sup>	1x10 <sup>5</sup>	5x10 <sup>5</sup>	1x10 <sup>6</sup>	5x10 <sup>6</sup>	1x10 <sup>7</sup>	1x10 <sup>8</sup>
370			650	1.0	Forged	S.E.V.	M B		1.047*	1.327	1.469	1.862	2.062	2.613*	2.894*	4.061*	
									14.11	11.13	10.05	7.935	5.655	5.106	3.639		
								.7464*	19.80								

S<sub>y</sub> = 48 ksi  
 S<sub>u</sub> = 41 ksi

ZK60A MAGNESIUM

Composition: See Page 168  
 (\*) Extrapolated Values

Code No.	TEST CONDITIONS				FATIGUE STRENGTH DISTRIBUTIONS AND THEIR PARAMETERS												
	Heat Treat	Surf. Fin.	Freq.	Temp.	K <sub>t</sub>	Other	DIST.	Param.	LIFE IN CYCLES								
									1x10 <sup>3</sup>	1x10 <sup>4</sup>	5x10 <sup>4</sup>	1x10 <sup>5</sup>	5x10 <sup>5</sup>	1x10 <sup>6</sup>	5x10 <sup>6</sup>	1x10 <sup>7</sup>	1x10 <sup>8</sup>

AXIAL (Completely Reversed)  
 Effect of Stress Concentration

Code No.	Heat Treat	Surf. Fin.	Freq.	Temp.	K <sub>t</sub>	Other	DIST.	Param.	1x10 <sup>3</sup>	1x10 <sup>4</sup>	5x10 <sup>4</sup>	1x10 <sup>5</sup>	5x10 <sup>5</sup>	1x10 <sup>6</sup>	5x10 <sup>6</sup>	1x10 <sup>7</sup>	1x10 <sup>8</sup>
371	T-5	M.P. 10 RMS		80	1.0		S.E.V.	M β	.5816* 32.74	.6630* 28.71	.7266 26.20	.7559 25.18	.8284 22.98	.8617 22.09	.9445 20.16	.9825 19.38	1.120* 16.99
372	T-5	Ground		80	2.4		L.E.V.	M β	.6709* 19.46	.8129 16.06	.9297 14.04	.9851 13.25	1.126 11.59	1.193 10.94	1.365 9.565	1.446 9.028	1.752* 7.450
373	T-5	Ground		80	3.4		Wetbull	θ X <sub>p</sub>	1.597* 22.15 18.11	1.736 16.44 13.30	1.686 13.33 10.83	1.686 12.19 9.900	1.686 9.891 8.033	1.686 9.040 7.341	1.686* 7.335 5.957	1.686* 6.702 5.444	1.686* 4.971 4.037

A-1.5.5 Nickel Alloys

Composition: See Page 168  
 (\*) Extrapolated Values

"A" NICKEL

S<sub>u</sub> = 66 ksi  
 S<sub>y</sub> = 38 ksi

Code No.	TEST CONDITIONS				FATIGUE STRENGTH DISTRIBUTIONS AND THEIR PARAMETERS												
	Heat Treat	Surf. Fin.	Freq.	Temp	R <sub>r</sub>	Other	DIST.	Other	LIFE IN CYCLES								
									1x10 <sup>3</sup>	1x10 <sup>4</sup>	5x10 <sup>4</sup>	1x10 <sup>5</sup>	5x10 <sup>5</sup>	1x10 <sup>6</sup>	5x10 <sup>6</sup>	1x10 <sup>7</sup>	1x10 <sup>8</sup>

PLATE BENDING (Completely Reversed)  
 Miscellaneous

Code No.	Heat Treat	Surf. Fin.	Freq.	Temp	R <sub>r</sub>	Other	DIST.	Other	1x10 <sup>3</sup>	1x10 <sup>4</sup>	5x10 <sup>4</sup>	1x10 <sup>5</sup>	5x10 <sup>5</sup>	1x10 <sup>6</sup>	5x10 <sup>6</sup>	1x10 <sup>7</sup>	1x10 <sup>8</sup>
374	1 hr @ 500°F			80	V-Not.		Wetball					.9980*	.9980*	.9980*	1.128	1.028*	1.140*
												29.21	19.80	16.75	11.37	9.608	5.519
												22.10	14.98	12.67	8.484	7.246	4.108

AXIAL (Completely Reversed)  
 Miscellaneous

Code No.	Heat Treat	Surf. Fin.	Freq.	Temp	R <sub>r</sub>	Other	DIST.	Other	1x10 <sup>3</sup>	1x10 <sup>4</sup>	5x10 <sup>4</sup>	1x10 <sup>5</sup>	5x10 <sup>5</sup>	1x10 <sup>6</sup>	5x10 <sup>6</sup>	1x10 <sup>7</sup>	1x10 <sup>8</sup>
375				572	1.0		L.E.V.			.3094	.4380	.5088*	.7204*	.8368*			
										49.19	34.74	29.91	21.12	18.19			

THERMAL (80°F to 572°F)  
 Miscellaneous

Code No.	Heat Treat	Surf. Fin.	Freq.	Temp	R <sub>r</sub>	Other	DIST.	Other	1x10 <sup>3</sup>	1x10 <sup>4</sup>	5x10 <sup>4</sup>	1x10 <sup>5</sup>	5x10 <sup>5</sup>	1x10 <sup>6</sup>	5x10 <sup>6</sup>	1x10 <sup>7</sup>	1x10 <sup>8</sup>
376				80-572	1.0		Wetball			2.203*	2.144	2.042	2.097*	2.039*			
										41.83	27.96	23.49	15.71	13.20			
										32.58	21.88	18.54	12.34	10.42			

$S_u = 75 \text{ ksi}$

FS-27 NICKEL BASE CERMET

Composition: See Page 168  
(\* Extrapolated Values)

Code No.	TEST CONDITIONS				FATIGUE STRENGTH DISTRIBUTIONS AND THEIR PARAMETERS												
	Heat Treat	Surf. Fin.	Freq.	Temp	$K_f$	Other	DIST.	Param.	LIFE IN CYCLES								
									1x10 <sup>3</sup>	1x10 <sup>4</sup>	5x10 <sup>4</sup>	1x10 <sup>5</sup>	5x10 <sup>5</sup>	1x10 <sup>6</sup>	5x10 <sup>6</sup>	1x10 <sup>7</sup>	1x10 <sup>8</sup>

PLATE BENDING (Completely Reversed)  
Effect of Test Temperature

377				1800	1.0		S.F.V. Wetbul	$\sigma_b$	1.593*	1.374	1.404	1.406	1.632	1.589	1.493	1.454	1.664*
								$\theta$	36.83	30.92	27.39	25.99	23.05	21.87	19.36	18.37	15.45
								$\sigma_x$	31.89	27.11	23.97	22.75	19.91	18.94	16.86	16.03	13.32
378				2000	1.0		S.F.V. Wetbul	$\beta$	.6727*	.8276	.9566	1.018	1.176	1.252	1.447	1.541	1.896*
								$M$	24.95	20.28	17.54	16.48	14.26	13.40	11.59	10.89	8.853

$S_u = 120 \text{ ksi}$   
 $S_y = 65 \text{ ksi}$

HASTELLOY C

Composition: See Page 168  
(\* Extrapolated Values)

AXIAL (Completely Reversed)  
Effect of Stress Concentration

379				80	1.0		S.F.V. Wetbul	$\sigma_b$	1.855	1.855	1.855	1.855	1.909	1.882	1.885*	1.885*	
								$\theta$	79.26	69.67	63.66	61.24	55.97	53.83	49.19	47.31	
								$\sigma_x$	67.52	59.35	54.23	52.17	47.53	45.79	41.90	40.31	
380				80	3.5		S.F.V. Wetbul	$\beta$	.4415	.7166	1.005	1.1629	1.631	1.887	2.647*	3.063*	
								$M$	83.50	51.45	36.68	31.70	22.80	19.53	13.92	12.03	



S<sub>u</sub> = 70 ksi

HASTELLOY - R235

Composition: See Page 168  
(\* ) Extrapolated Values

Code No.	TEST CONDITIONS				FATIGUE STRENGTH DISTRIBUTIONS AND THEIR PARAMETERS										
	Heat Treat	Surf. Fin.	Freq.	Temp.	Other	DIST.	Param.	LIFE IN CYCLES							
								1x10 <sup>3</sup>	1x10 <sup>4</sup>	5x10 <sup>4</sup>	1x10 <sup>5</sup>	1x10 <sup>5</sup>	5x10 <sup>5</sup>	1x10 <sup>6</sup>	5x10 <sup>6</sup>

AXIAL (Completely Reversed)  
Effect of Heat Treatment

Code No.	Heat Treat	Surf. Fin.	Freq.	Temp.	Other	DIST.	Param.	1x10 <sup>3</sup>	1x10 <sup>4</sup>	5x10 <sup>4</sup>	1x10 <sup>5</sup>	1x10 <sup>5</sup>	5x10 <sup>5</sup>	1x10 <sup>6</sup>	5x10 <sup>6</sup>	1x10 <sup>7</sup>	1x10 <sup>8</sup>
381	HT-18		60	80			β						.2881 68.78	.3252* 60.94	.4308* 46.01		
382	HT-19		60	80		L.F.V.	β	1.485	1.485	1.485	1.485	1.081	.8983	.6708	.8225*		.9775* 31.26 27.42
383	HT-18		60	1650		S.E.V.	β	.3544* 49.36	.4971* 35.19	.6298 27.77	.6973 25.08	.8834* 19.80	.9782* 17.88	1.239* 14.11	1.372* 12.75		1.924* 9.089
384	HT-19		60	1050		Weibull	β	1.608* 31.99 29.05	1.567* 30.50 27.75	1.539 29.50 26.87	1.527 29.08 26.50	1.500 28.13 25.66	1.489 27.73 25.30	1.463* 26.82 24.50	1.452* 26.44 24.16		1.415* 25.21 23.07

Effect of Stress Concentration

Code No.	Heat Treat	Surf. Fin.	Freq.	Temp.	Other	DIST.	Param.	1x10 <sup>3</sup>	1x10 <sup>4</sup>	5x10 <sup>4</sup>	1x10 <sup>5</sup>	1x10 <sup>5</sup>	5x10 <sup>5</sup>	1x10 <sup>6</sup>	5x10 <sup>6</sup>	1x10 <sup>7</sup>	1x10 <sup>8</sup>
385	HT-18		60	80		L.F.V.	β						.2881 68.78	.3252* 60.94	.4308* 46.01		
386	HT-19		60	80	3.4	Weibull	β	5.022* 52.90 37.66	5.254* 43.89 30.74	5.822* 38.52 25.90	4.892* 36.40 26.14	5.473 31.95 22.04	5.713 30.20 20.47	5.269 26.50 18.54	5.215 25.05 17.59		5.362* 20.78 14.44

S<sub>u</sub> = 64 ksi  
Composition: See Page 168  
(\* ) Extrapolated Values

HASTELLOY - R235 (Cont'd)

Code No.	TEST CONDITIONS				FATIGUE STRENGTH DISTRIBUTIONS AND THEIR PARAMETERS											
	Heat Treat	Surf. Fin.	Freq.	Temp.	K <sub>t</sub>	Other	DIST.	T <sub>max</sub>	LIFE IN CYCLES							
									1x10 <sup>3</sup>	1x10 <sup>4</sup>	5x10 <sup>4</sup>	1x10 <sup>5</sup>	5x10 <sup>5</sup>	1x10 <sup>6</sup>	5x10 <sup>6</sup>	1x10 <sup>7</sup>

AXIAL (Completely Reversed)  
Effect of Test Temperature

387	HT-18			60	80	1.0								.2881	.3252*	.4308*					
388	HT-18			60	1650	1.0								.8834*	.9782*	1.239*	1.372*	1.924*	9.089		
389	HT-19			60	80	1.0								1.081	.8983	.6708	.8225*	.9775*	31.26	27.42	
390	HT-19			60	1200	1.0								2.747	2.670	2.501	2.431	2.213*	39.01	35.51	
391	HT-19			60	1650	1.0								1.500	1.489	1.463*	1.452*	1.415*	26.44	25.21	23.07

HT-18: Vacuum Annealed at 1850°F, 1/2 hr, F.C., 1.5 hr; tempered at 2150°F, 0.5 hr, AC  
Sol. h.T. at 1800°F, 4 hr, O.Q., Aged at 1350°F, 16 hrs, AC-Hot Rolled

HT-19: Preheat 1400°F, 0.5 hr, Hardened 1900, 0.5 hr, A.C., Tempered at 1050°F, 2 hrs, Retemper, 2 hrs-Cast

Composition: See Page 168  
 (\*) Extrapolated Values

**INCOLOY 901 (AMS-5560A)**

S<sub>u</sub> = 182 ksi  
 S<sub>y</sub> = 116 ksi

Code 150	TEST CONDITIONS				FATIGUE STRENGTH DISTRIBUTIONS AND THEIR PARAMETERS											
	Heat Treat	Surf. Fin.	Freq.	Temp	R <sub>r</sub>	Other	DIST.	Param.	1x10 <sup>3</sup>	1x10 <sup>4</sup>	5x10 <sup>4</sup>	1x10 <sup>5</sup>	5x10 <sup>5</sup>	1x10 <sup>6</sup>	5x10 <sup>6</sup>	1x10 <sup>7</sup>

**AXIAL (Completely Reversed)  
 Effect of Test Temperature**

Code 150	Heat Treat	Surf. Fin.	Freq.	Temp	R <sub>r</sub>	Other	DIST.	Param.	1x10 <sup>3</sup>	1x10 <sup>4</sup>	5x10 <sup>4</sup>	1x10 <sup>5</sup>	5x10 <sup>5</sup>	1x10 <sup>6</sup>	5x10 <sup>6</sup>	1x10 <sup>7</sup>	1x10 <sup>8</sup>
392	2000°F, 2 hrs, W.Q., 1450°F, 2 hrs, AC, 1325°F, 24 hrs, AC.		30	80	1.0		Webull	S.E.V.	2.896* 136.2 113.0	2.862* 102.1 84.95	2.773 83.55 69.77	2.964 76.64 63.42	2.948 62.68 51.91	3.006 57.48 47.47	2.751 47.00 39.29	2.796* 43.11 35.96	2.894* 32.33 26.85
393			30	600	1.0		Webull	Normal	5.726* 123.1	4.169* 89.67	3.339 71.83	3.035 65.28	2.431* 52.29	2.209* 47.52	1.770* 38.07	1.608* 34.60	1.171* 25.19
394			30	1000	1.0		S.E.V.	B M	.1606* 103.9	1.987 84.05	.2305 72.45	.2457 67.96	.2851 58.57	.3039* 54.94	.3526* 47.36	.3759* 44.42	.4650* 35.91
395			30	1400	1.0		S.E.V.	B M	.7488* 76.27	.8777 65.06	.9809 58.22	1.028 55.50	1.149 49.67	1.206* 47.35	1.347* 42.37	1.413* 40.39	1.657* 34.46
396			30	1800	1.0		Webull	Webull	7.858* 40.60 30.39	7.875* 27.01 20.21	7.736 20.32 15.28	7.381 17.97 13.70	7.564* 13.52 10.23	8.025* 11.96 8.899	7.959* 9.000 6.711	7.418* 7.961 6.058	7.959* 5.298 3.950

S<sub>u</sub> = 88-89 ksi  
 S<sub>y</sub> = 33-37 ksi

INCONEL

Composition: See Page 168  
 (\*) Extrapolated Values

Code No.	TEST CONDITIONS				FATIGUE STRENGTH DISTRIBUTIONS AND THEIR PARAMETERS											
	Heat Treat	Surt. Fin.	Freq.	Temp	K <sub>t</sub>	Other	DIST.	Param.	LIFE IN CYCLES							
									1x10 <sup>3</sup>	1x10 <sup>4</sup>	5x10 <sup>4</sup>	1x10 <sup>5</sup>	5x10 <sup>5</sup>	1x10 <sup>6</sup>	5x10 <sup>6</sup>	1x10 <sup>7</sup>

**AXIAL (Completely Reversed)  
 Effect of Frequency (Creep)**

397	Annealed at 1900°F, 1 hr		1.0	1500	1.0		L.E.V.	β	1.084*	1.254	1.388	1.450*	1.605*	1.676*	1.855*	1.938*	2.241*
								M	22.47	19.43	17.56	16.81	15.18	14.54	13.13	12.57	10.87
398			1.0	1500	1.0		Wetbulb	β	3.974*	3.937	3.937*	3.937*	3.937*	3.937*	3.937*	3.937*	3.937*
								φ	24.69	17.84	14.21	12.89	10.27	9.318	7.425	6.733	4.866
								X <sub>o</sub>	19.64	14.22	11.33	10.27	8.190	7.427	5.918	5.367	3.878

262

**Effect of Test Temperature**

Code No.	Heat Treat	Surt. Fin.	Freq.	Temp	K <sub>t</sub>	Other	DIST.	Param.	1x10 <sup>3</sup>	1x10 <sup>4</sup>	5x10 <sup>4</sup>	1x10 <sup>5</sup>	5x10 <sup>5</sup>	1x10 <sup>6</sup>	5x10 <sup>6</sup>	1x10 <sup>7</sup>	1x10 <sup>8</sup>
400	HT-20		153	80	1.0		L.E.V.	β	.9047*	1.206	1.475*	1.609*	1.967*	2.145*	2.624*	2.862*	3.816*
								M	70.04	52.52	42.94	39.38	32.20	29.53	24.14	22.14	16.60
401	HT-20		153	200	1.0		L.E.V.	β	.1360*	.1510*	.1626	.1678*	.1806*	.1864*	.2006*	.2070*	.2299*
								M	62.15	55.96	52.00	50.38	46.81	45.35	42.14	40.83	36.76
402	HT-20		153	400	1.0		L.E.V.	β	.4915*	.5976	.6851	.7266*	.8330*	.8835*	1.012*	1.074*	1.306*
								M	57.69	47.44	41.38	39.02	34.03	32.09	27.99	26.39	21.70
403	HT-20		153	600	1.0		L.E.V.	β	.3652*	.4227	.4681	.4891	.5417	.5660*	.6269*	.6550*	.7580*
								M	61.37	53.03	47.89	45.83	41.38	39.60	35.76	34.22	29.57

HT-20: Vacuum Annealed at 1850°F, 0.5 hr, F.C. in 1.5 hr; 2150°F, 0.5 hr A.C., Solution H.T.  
 1800°F-4 hrs, 0.Q. Aged 1350°F, 16 hrs, A.C.

S<sub>u</sub> = 88-89 ksi  
S<sub>y</sub> = 33-37 ksi

INCONEL (Cont'd)

Composition: See Page 168  
(\* ) Extrapolated Values

Code No.	TEST CONDITIONS				FATIGUE STRENGTH DISTRIBUTIONS AND THEIR PARAMETERS										
	Heat Treat	Surf. Fin.	Req. Temp.	R <sub>r</sub>	Other	DIST. Param.	LIFE IN CYCLES								
							1x10 <sup>3</sup>	1x10 <sup>4</sup>	5x10 <sup>4</sup>	1x10 <sup>5</sup>	5x10 <sup>5</sup>	1x10 <sup>6</sup>	5x10 <sup>6</sup>	1x10 <sup>7</sup>	1x10 <sup>8</sup>

AXIAL (Completely Reversed)  
Effect of Test Temperature

404	Annealed at 1900° F 1 hr		1.0	1300	1.0		6.458*	6.676	6.188	5.992	6.567*	6.397*	6.023*	6.874*	6.421*
							31.06	28.78	27.28	26.66	25.28	24.70	23.42	22.89	21.20
							27.41	25.29	24.19	23.72	22.26	21.82	20.82	20.04	18.72
405			1.0	1500	1.0		1.084*	1.254	1.388	1.450*	1.605*	1.676*	1.855*	1.938*	2.241*
							22.47	19.43	17.56	16.81	15.18	14.54	13.13	12.57	10.87

Composition: See Page 169  
(\* ) Extrapolated Values

INCONEL 713C

AXIAL (Completely Reversed)  
Effect of Stress Concentration

406			1.0	1700	1.0		1.020*	1.087*	1.127*	1.144	1.179	1.194	1.206	1.206	1.168*
							40.34	36.87	34.63	33.71	31.65	30.81	28.93	28.15	25.72
							36.93	33.68	31.58	30.71	28.80	28.02	26.30	25.59	23.41
407	Mechanical Polishing		2.9	1700	1.0		.5602*	.6030*	.6347	.6489	.6831	.6984	.7352	.7517	.8090*
							34.76	32.30	30.68	30.01	28.51	27.88	26.49	25.91	24.07

Su = 186-225 ksi  
 Sy = 146-194 ksi  
 INCONEL-X (AMS-5667)  
 Composition: See Page 169  
 (\*) Extrapolated Values

+ Code No.	TEST CONDITIONS				Heat Treat.	Surt. Fin.	Freq.	Temp. °F	K <sub>t</sub>	Other	DIST.	FORM.	FATIGUE STRENGTH DISTRIBUTIONS AND THEIR PARAMETERS							
	LIFE IN CYCLES																			
	1x10 <sup>3</sup>	1x10 <sup>4</sup>	5x10 <sup>4</sup>	1x10 <sup>5</sup>	5x10 <sup>5</sup>	1x10 <sup>6</sup>	5x10 <sup>6</sup>	1x10 <sup>7</sup>	1x10 <sup>8</sup>											

ROTARY BEAM BENDING  
 Effect of Heat Treatment

+ Code No.	Heat Treat.	Surt. Fin.	Freq.	Temp. °F	K <sub>t</sub>	Other	L.E.V.	Normal	n	σ	LIFE IN CYCLES								
											1x10 <sup>3</sup>	1x10 <sup>4</sup>	5x10 <sup>4</sup>	1x10 <sup>5</sup>	5x10 <sup>5</sup>	1x10 <sup>6</sup>	5x10 <sup>6</sup>	1x10 <sup>7</sup>	1x10 <sup>8</sup>
408	HT-21		183	80	1.0	Vacuum Melt		Normal	10	179.1	.1298*	.1723*	.2100*	.2286	.2786	.3034	.3697	.4026	.5342*
											160.8	121.2	99.50	91.38	74.98	68.86	56.51	51.90	39.11
409	HT-22		183	80	1.0	Vacuum Melt		Normal	10	179.1	15.06*	11.21*	9.124*	8.349*	6.794	6.217	5.058	4.629	3.446*
											179.1	133.4	108.5	99.32	80.82	73.95	60.17	55.06	41.00

AXIAL (Completely Reversed)  
 Miscellaneous

+ Code No.	Heat Treat.	Surt. Fin.	Freq.	Temp. °F	K <sub>t</sub>	Other	L.E.V.	Normal	n	σ	LIFE IN CYCLES								
											1x10 <sup>3</sup>	1x10 <sup>4</sup>	5x10 <sup>4</sup>	1x10 <sup>5</sup>	5x10 <sup>5</sup>	1x10 <sup>6</sup>	5x10 <sup>6</sup>	1x10 <sup>7</sup>	1x10 <sup>8</sup>
410				80	1.0		Normal	10	10	148.9	6.722*	4.787	3.775	3.408	2.688	2.427*	1.914*	1.728*	1.230*
											148.9	106.0	83.63	75.51	59.55	53.77	42.41	38.29	27.26

HT-21: 1200°F, 4 hrs, AC, Forged and Swaged  
 HT-22: Aged 1350°F, 16 hrs, AC, Forged and Swaged

S<sub>u</sub> = 121-225 ksi  
 S<sub>y</sub> = 75-189 ksi

INCONEL - 718

Composition: See Page 169  
 (\*) Extrapolated Values

Code No.	TEST CONDITIONS				FATIGUE STRENGTH DISTRIBUTIONS AND THEIR PARAMETERS													
	Heat Treat	Surr. Fin.	Freq.	Temp. °F	K <sub>t</sub>	Other	Dist.	Param.	LIFE IN CYCLES									
									1x10 <sup>3</sup>	1x10 <sup>4</sup>	5x10 <sup>4</sup>	1x10 <sup>5</sup>	5x10 <sup>5</sup>	1x10 <sup>6</sup>	5x10 <sup>6</sup>	1x10 <sup>7</sup>	1x10 <sup>8</sup>	

ROTARY BEAM BENDING

Miscellaneous

411	HT-23		167	80	1.0		S.E.V.	β M	.5044* 126.9	.5623* 113.8	.6068* 105.4	.6270 102.0	.6765 94.62	.6990 91.57	.7543* 84.86	.7794* 82.13	.8691* 73.66
412	HT-24		167	800	1.0		S.E.V.	β M	.1596* 117.0	.1708* 109.3	.1791* 104.3	.1828* 102.2	.1916 97.48	.1956 95.51	.2051 91.09	.2093* 89.26	.2240* 83.41

AXIAL (Completely Reversed)

Effect of Heat Treatment

413	Stress Solut. H.T.	Reliev.	Mechanical Polish	50	80	1.0		S.E.V.	β M	.5386* 80.46	.5756 75.29	.6029 71.88	.6150 70.46	.6442* 67.27	.6572* 65.94	.6884* 62.96	.7022* 61.71	.7504* 57.75
414				50	80	1.0		Wetbulb	β M	1.236* 91.08	1.095* 75.37	.9548 66.05	1.537 62.80	1.392 54.98	1.045 51.76	1.440 45.60	1.627 43.18	1.806* 35.86

HT-23: 1750°F, 1 hr, A.C. 1325°F, 8 hrs, F.C. to 1150°F and Hold for 10 hrs.

HT-24: 1325°F, 8 hrs, F.C. to 1150°F and hold for 18 hrs

Su = 121-225 ksi  
 Sy = 75-189 ksi  
 Composition: See Page 169  
 (\*) Extrapolated Values

INCONEL - 718 (Cont'd)

+Code No.	TEST CONDITIONS				FATIGUE STRENGTH DISTRIBUTIONS AND THEIR PARAMETERS										
	Heat Treated	Surf. Fin.	Freq.	Temp	R <sub>r</sub>	Other	DISTR.	LIFE IN CYCLES							
								1x10 <sup>3</sup>	1x10 <sup>4</sup>	5x10 <sup>4</sup>	1x10 <sup>5</sup>	5x10 <sup>5</sup>	1x10 <sup>6</sup>	5x10 <sup>6</sup>	1x10 <sup>7</sup>

AXIAL (Completely Reversed)  
 Effect of Stress Concentration

+Code No.	Heat Treated	Surf. Fin.	Freq.	Temp	R <sub>r</sub>	Other	DISTR.	β	M	LIFE IN CYCLES									
										1x10 <sup>3</sup>	1x10 <sup>4</sup>	5x10 <sup>4</sup>	1x10 <sup>5</sup>	5x10 <sup>5</sup>	1x10 <sup>6</sup>	5x10 <sup>6</sup>	1x10 <sup>7</sup>	1x10 <sup>8</sup>	
415	Solution Heat Treated		50	80	1.0		S.T.V.	β	5386*	5756	6029	6150	6442*	6572*	6884*	7022*	7504*		
								M	80.46	75.29	71.88	70.46	67.27	65.94	62.96	61.71	57.75		
416			50	80	3.5		Wetbulb	β	6724*	6908	6775	6726	6626	6592	6520*	6446*	6183*		
								σ	88.09	64.18	51.43	46.75	37.46	34.06	27.29	24.81	18.07		
417			50	80	1.0		Wetbulb	β	1236*	1095*	9548	1537	1392	1045	1440	1627	1806*		
								σ	91.08	75.37	66.05	62.80	54.98	51.76	45.60	43.18	35.86		
418			50	80	3.0		Wetbulb	β	1088*	7352*	1053*	5474*	7763	8313	9320	9679*	1069*		
								σ	37.78	32.75	29.89	28.53	25.94	24.91	22.66	21.75	18.99		
419			50	1000	1.0		Wetbulb	β	3095*	3047	3016	3003	2974	2962	2935*	2924*	2889*		
								σ	78.28	72.41	68.57	66.98	63.42	61.95	58.67	57.31	53.01		
420			50	1000	3.0		Wetbulb	β	372*	3237*	3228	3228	3444	3228*	3344*	3244*	3212*		
								σ	77.91	48.84	35.24	30.62	22.10	19.19	13.85	12.03	7.547		



S<sub>y</sub> = 121-225 ksi  
 S<sub>u</sub> = 75-189 ksi

INCONEL - 718 (Cont'd)

Composition: See Page 169  
 (\*) Extrapolated Values

+Code No.	TEST CONDITIONS				FATIGUE STRENGTH DISTRIBUTIONS AND THEIR PARAMETERS											
	Heat Treat	Surt. Fin.	Freq.	Temp	R <sub>r</sub>	Other	DIST.	LIFE IN CYCLES								
								1x10 <sup>3</sup>	1x10 <sup>4</sup>	5x10 <sup>4</sup>	1x10 <sup>5</sup>	5x10 <sup>5</sup>	1x10 <sup>6</sup>	5x10 <sup>6</sup>	1x10 <sup>7</sup>	1x10 <sup>8</sup>

AXIAL (Completely Reversed)  
 Effect of Stress Concentration

+Code No.	Heat Treat	Surt. Fin.	Freq.	Temp	R <sub>r</sub>	Other	DIST.	σ		β		M		N			
								Normal	I.F.V.	Normal	I.F.V.	Normal	I.F.V.	Normal	I.F.V.		
421	Stress Relieved		50	1400	1.0			3.024*	2.913	2.839	2.807	2.735	2.705	2.635	2.606	2.511*	
								48.36	46.60	45.40	44.90	43.75	43.26	42.15	41.68	40.16	
422	Stress Relieved		50	1400	3.0			.7166*	.7806*	.8287	.8503	.9027	.9262	.9833	1.008	1.099*	
								25.44	23.35	22.00	21.44	20.20	19.68	18.54	18.07	16.59	

Effect of Test Temperature

+Code No.	Heat Treat	Surt. Fin.	Freq.	Temp	R <sub>r</sub>	Other	DIST.	σ		β		M		N		
								Normal	I.F.V.	Normal	I.F.V.	Normal	I.F.V.	Normal	I.F.V.	
423	Stress Relieved		50	80	1.0			1.236*	1.095*	.9548	1.537	1.392	1.045	1.440	1.627	1.806*
								91.08	75.37	66.05	62.80	54.98	51.76	45.60	43.18	35.86
424	Stress Relieved		50	1000	1.0			80.27	66.93	58.97	54.23	47.97	46.06	39.65	37.04	30.33
								3.095*	3.047	3.016	3.003	2.974	2.962	2.935*	2.924*	2.889*
								78.28	72.41	68.57	66.98	63.42	61.95	58.67	57.31	53.01
425	Stress Relieved		50	1200	1.0			57.61	53.52	50.82	49.70	47.18	46.14	43.80	42.82	39.73
								1.068*	1.182	1.251	.8946	.7890	.8509	.9745	1.024*	1.160*
								63.97	59.09	55.89	54.37	51.34	50.14	47.46	46.35	42.82
426	Stress Relieved		50	1400	1.0			59.70	54.89	51.75	51.06	48.37	47.16	44.45	43.33	39.82
								3.024*	2.913	2.839	2.807	2.735	2.705	2.635	2.606	2.511*
								48.36	46.60	45.40	44.90	43.75	43.26	42.15	41.68	40.16

S<sub>u</sub> = 121-225 ksi  
 S<sub>y</sub> = 75-189 ksi

INCONEL - 718 (Cont'd)

Composition: See Page 169  
 (\*) Extrapolated Values

4 Code No.	TEST CONDITIONS				FATIGUE STRENGTH DISTRIBUTIONS AND THEIR PARAMETERS											
	Heat Treat	Surf. Fin.	Freq.	Temp °F	K <sub>t</sub>	Other	DIST.	Param.	LIFE IN CYCLES							
									1x10 <sup>3</sup>	1x10 <sup>4</sup>	5x10 <sup>4</sup>	1x10 <sup>5</sup>	5x10 <sup>5</sup>	1x10 <sup>6</sup>	5x10 <sup>6</sup>	1x10 <sup>7</sup>

AXIAL (Completely Reversed)  
 Effect of Test Temperature

4 Code No.	Stress Relieved	L.F.V. M	b	θ	X <sub>0</sub>	Webull	Webull	LIFE IN CYCLES							
								1.088*	.7352*	1.053*	.5474*	.7763	.8313	.9320	.9679*
427	3.0							37.78	32.75	29.89	28.53	25.94	22.66	21.75	18.99
								34.00	30.00	26.95	26.22	23.73	22.73	20.57	19.71
428	3.0							3.372*	3.237*	3.228	3.228	3.444	3.344*	3.244*	3.212*
								77.91	48.84	35.24	30.62	22.10	19.19	13.85	12.03
429	3.0							71.66*	.7806*	.8287	.8503	.9027	.9833	1.008	1.099*
								25.44	23.35	22.00	21.44	20.20	19.68	18.54	18.07

S<sub>u</sub> = 185 ksi  
 S<sub>y</sub> = 125 ksi

Composition: See Page 169  
 (\*) Extrapolated Values

WASPALLOY  
 ROTARY BEAM BENDING  
 Miscellaneous

4 Code No.	Normal	n	σ	LIFE IN CYCLES			
				7.641*	6.719*	6.356*	5.589
430	1.0			107.0	94.11	89.04	78.29
				128.6	107.0	94.11	89.04
HT-25				5.288	4.650	4.399	3.659*
				74.07	65.13	61.62	51.26

HT-25: Sol. H.T. 1975°F, 4 hrs, A.C., Aged 1550°F, 24 hrs, A.C. Aged 1400°F, 16 hrs, A.C.

S<sub>y</sub> = 174 ksi  
 S<sub>u</sub> = 115 ksi

INCONEL - 751 (INCO-X550)

Composition: See Page 169  
 (\*) Extrapolated Values

+Code No.	TEST CONDITIONS				FATIGUE STRENGTH DISTRIBUTIONS AND THEIR PARAMETERS												
	Heat Treat	Surt. Fin.	Freq.	Temp. F	R <sub>r</sub>	Other	DIST.	Param.	LIFE IN CYCLES								
									1x10 <sup>3</sup>	1x10 <sup>4</sup>	5x10 <sup>4</sup>	1x10 <sup>5</sup>	5x10 <sup>5</sup>	1x10 <sup>6</sup>	5x10 <sup>6</sup>	1x10 <sup>7</sup>	1x10 <sup>8</sup>

AXIAL (Completely Reversed)  
 Effect of Test Temperature

+Code No.	Heat Treat	Surt. Fin.	Freq.	Temp. F	R <sub>r</sub>	Other	DIST.	Param.	LIFE IN CYCLES								
									1x10 <sup>3</sup>	1x10 <sup>4</sup>	5x10 <sup>4</sup>	1x10 <sup>5</sup>	5x10 <sup>5</sup>	1x10 <sup>6</sup>	5x10 <sup>6</sup>	1x10 <sup>7</sup>	1x10 <sup>8</sup>
431	HT-26			80	3.4	Hot Rolled	S.E.V.	M β	.1607*	.2327*	.3014*	.3369	.4364	.4878	.6319	.7063*	1.022*
									100.1	69.17	53.40	47.77	36.88	32.99	25.47	22.78	15.74
432	HT-26			1350	3.4	Hot Rolled	L.F.V.	M β	.1847*	.2108*	.2313	.2407	.2640	.2747	.3014	.3137	.3581*
									40.88	35.81	32.64	31.36	28.59	27.47	25.04	24.06	21.08

Miscellaneous

+Code No.	Heat Treat	Surt. Fin.	Freq.	Temp. F	R <sub>r</sub>	Other	DIST.	Param.	LIFE IN CYCLES								
									1x10 <sup>3</sup>	1x10 <sup>4</sup>	5x10 <sup>4</sup>	1x10 <sup>5</sup>	5x10 <sup>5</sup>	1x10 <sup>6</sup>	5x10 <sup>6</sup>	1x10 <sup>7</sup>	1x10 <sup>8</sup>
433	HT-26			1500	1.0	Hot Rolled	Weibull	q	1.434*	.9463*	.7951*	1.434*	1.155*	.8998*	1.434	1.419	.8941*
									96.98	75.43	63.30	58.81	49.35	45.73	38.45	35.66	27.73
							X <sub>0</sub>	93.30	73.17	61.54	56.58	47.71	44.39	36.99	34.32	26.92	

HT-26: Sol. H.T. 2150°F, 1 hr, AC, Aged 1600°F, 4 hrs, AC, Aged 1350°F, 4 hrs, AC

Composition: See Page 169  
 (\*) Extrapolated Values

INOR - 8

+Code No.	TEST CONDITIONS					FATIGUE STRENGTH DISTRIBUTIONS AND THEIR PARAMETERS										
	Heat Treat	Surt. Fin.	Freq.	Temp	K <sub>t</sub>	Other	DISTR.	Param.	LIFE IN CYCLES							
									1x10 <sup>3</sup>	1x10 <sup>4</sup>	5x10 <sup>4</sup>	1x10 <sup>5</sup>	5x10 <sup>5</sup>	1x10 <sup>6</sup>	5x10 <sup>6</sup>	1x10 <sup>7</sup>

ROTARY BEAM BENDING  
 Effect of Test Temperature

Code	Heat Treat	Surt. Fin.	Temp	K <sub>t</sub>	Other	DISTR.	Param.	1x10 <sup>3</sup>	1x10 <sup>4</sup>	5x10 <sup>4</sup>	1x10 <sup>5</sup>	5x10 <sup>5</sup>	1x10 <sup>6</sup>	5x10 <sup>6</sup>	1x10 <sup>7</sup>	1x10 <sup>8</sup>
434	HT-27		1100	1.0		NORMAL	n <sub>s</sub>	5.861*	5.392	5.086	4.960	4.680	4.564	4.305*	4.198*	3.863*
							n <sub>b</sub>	73.59	67.70	63.87	62.29	58.76	57.30	54.06	52.72	48.50
435	HT-27	Mechanical Polishing	1300	1.0		L.F.V.	β	.2343*	.2581*	.2761	.2843	.3042	.3132	.3352	.3451	.3801*
							M	60.58	54.99	51.39	49.92	46.65	45.31	42.34	41.13	37.33
436	HT-27		1500	1.0		NORMAL	n <sub>s</sub>	5.624*	4.982	4.577	4.412	4.054	3.908	3.590	3.462	3.066*
							n <sub>b</sub>	52.86	46.82	43.02	41.47	38.10	36.73	33.75	32.54	28.82

S<sub>y</sub> = 76 ksi  
 S<sub>u</sub> = 37 ksi

Composition: See Page 169  
 (\*) Extrapolated Values

MONEL  
 PLATE BENDING (Completely Reversed)  
 Miscellaneous

Code	Heat Treat	Surt. Fin.	Temp	K <sub>t</sub>	Other	DISTR.	Param.	1x10 <sup>3</sup>	1x10 <sup>4</sup>	5x10 <sup>4</sup>	1x10 <sup>5</sup>	5x10 <sup>5</sup>	1x10 <sup>6</sup>	5x10 <sup>6</sup>	1x10 <sup>7</sup>	1x10 <sup>8</sup>
437	1 hr @ 932°F		80	V-Not.		Webull	b	1.341*	1.341*	1.341*	1.341*	1.341*	1.341	1.341	1.341*	1.341*
							θ	17.60	14.27	12.32	11.57	9.992	9.380	8.100	7.605	6.165
							ρ	11.02	8.939	7.719	7.247	6.258	5.875	5.073	4.763	3.861

HT-27: Solution Annealed at 2100°F, 1 hr, AC, Stress Relieved at 1600°F, 1 hr.

Composition: See Page 169  
 (\*) Extrapolated Values

NICRO - TUNG

S<sub>u</sub> = 130 ksi  
 S<sub>y</sub> = 120 ksi

+Code No.	TEST CONDITIONS				FATIGUE STRENGTH DISTRIBUTIONS AND THEIR PARAMETERS											
	Heat Treat	Surt. Fin.	Freq.	Temp °F	K <sub>t</sub>	Other	DISTR.	Param.	LIFE IN CYCLES							
									1x10 <sup>3</sup>	1x10 <sup>4</sup>	5x10 <sup>4</sup>	1x10 <sup>5</sup>	5x10 <sup>5</sup>	1x10 <sup>6</sup>	5x10 <sup>6</sup>	1x10 <sup>7</sup>

AXIAL (Completely Reversed)  
 Effect of Stress Concentration

438			50	1200	1.0		S.E.V.	M	.1709*	.2141*	.2506*	.2681*	.3139	.3359	.3932	.4208	.5271*
									87.10	69.53	59.40	55.51	47.42	44.31	37.86	35.38	28.24
439			50	1200	2.0		L.E.V.	M	.3356*	.3858*	.4253*	.4435	.4888	.5098*	.5619*	.5860*	.6735*
									48.33	42.04	38.14	36.57	33.18	31.82	28.87	27.68	24.08
440			50	1500	1.0		L.E.V.	M	.1610*	.1857*	.2051*	.2141	.2366	.2469	.2728	.2848	.3285*
									57.79	50.11	45.36	43.45	39.33	37.68	34.10	32.67	28.33
441			50	1500	2.0		Wetbull	q	.9361*	.9361*	.9361	.9361	.9361*	.9361*	.9361*	.9361*	.7175
									47.79	42.83	39.68	38.39	35.56	34.40	31.87	30.83	27.56
442			50	1700	1.0		Wetbull	q	1.840*	1.840*	1.840*	1.840*	1.840	1.840	1.874	1.839	1.840*
									45.85	38.70	34.37	32.66	29.01	27.56	24.44	23.26	19.63
443			50	1700	2.0		S.E.V.	M	.5905*	.6181*	.6379	.6466	.6673	.6764	.6981	.7076*	.7402*
									35.40	33.84	32.79	32.35	31.35	30.92	29.97	29.56	28.26

NICRO - TUNG (Cont'd) Composition: See Page 169  
 (\*) Extrapolated Values

S<sub>y</sub> = 130 ksi  
 S<sub>u</sub> = 120 ksi

+Code No.	TEST CONDITIONS				FATIGUE STRENGTH DISTRIBUTIONS AND THEIR PARAMETERS												
	Heat Treat	Surf. Fin.	Freq. Hz	Temp °F	R <sub>r</sub>	Other	DIST.	Param	LIFE IN CYCLES								
									1x10 <sup>3</sup>	1x10 <sup>4</sup>	5x10 <sup>4</sup>	1x10 <sup>5</sup>	5x10 <sup>5</sup>	1x10 <sup>6</sup>	5x10 <sup>6</sup>	1x10 <sup>7</sup>	1x10 <sup>8</sup>

AXIAL (Completely Reversed)  
 Effect of Test Temperature

444			50	1200	1.0		S.E.V.	β	.1709*	.2141*	.2506*	.2681*	.3139	.3359	.3932	.4208	.5271*
								M	87.10	69.53	59.40	55.51	47.42	44.31	37.86	35.38	28.24
445			50	1500	1.0		L.E.V.	β	.1610*	.1857*	.2051*	.2141	.2366	.2469	.2728	.2848	.3285*
								M	57.79	50.11	45.36	43.45	39.33	37.68	34.10	32.67	28.33
446			50	1700	1.0		Webull	ρ	1.840*	1.840*	1.840*	1.840*	1.840	1.840	1.874	1.839	1.840*
								θ	53.75	45.36	40.29	38.28	34.00	32.31	28.70	27.27	23.01
								α <sub>0</sub>	45.85	38.70	34.37	32.66	29.01	27.56	24.44	23.26	19.63
447			50	1200	2.0		L.E.V.	β	.3356*	.3858*	.4253*	.4435	.4888	.5098*	.5619*	.5860*	.6735*
								M	48.33	42.04	38.14	36.57	33.18	31.82	28.87	27.68	24.08
448			50	1500	2.0		Webull	ρ	.9361*	.9361*	.8361	.9361	.9361*	.9361*	.9361*	.9361*	.7175*
								θ	47.79	42.83	39.68	38.39	35.56	34.40	31.87	30.83	27.56
								α <sub>0</sub>	44.58	39.95	37.00	35.80	33.16	32.09	29.72	28.76	25.92
449			50	1700	2.0		S.E.V.	β	.5909*	.6181*	.6379	.6466	.6673	.6764	.6981	.7076*	.7402*
								M	35.40	33.84	32.79	32.35	31.35	30.92	29.97	29.56	28.26

S<sub>u</sub> = 44-87 ksi  
S<sub>y</sub> = 35-76 ksi

NIMONIC - 95

Composition: See Page 169  
(\* ) Extrapolated Values

+Code No.	TEST CONDITIONS				FATIGUE STRENGTH DISTRIBUTIONS AND THEIR PARAMETERS												
	Heat Treat	Surt.	Vln.	Freq.	Temp °F	K <sub>t</sub>	Other	DIST.	Param.	LIFE IN CYCLES							
										1x10 <sup>3</sup>	1x10 <sup>4</sup>	5x10 <sup>4</sup>	1x10 <sup>5</sup>	5x10 <sup>5</sup>	1x10 <sup>6</sup>	5x10 <sup>6</sup>	1x10 <sup>7</sup>

AXIAL (Completely Reversed)  
Effect of Heat Treatment

450	HT-28			98	1560	1.0		S.F.V.	M β	.2939* 83.70	.3678* 66.87	.4304* 57.16	.4605* 53.42	.5387 45.66	.5764 42.68	.6743 36.48	.7215 34.09	.9031* 27.24
451	HT-30			98	1560	1.0		Webull	β q		1.559* 76.40 66.54	1.520* 70.09 61.18	1.614* 57.43 49.86	1.796* 52.76 45.29	1.490 43.13 37.71	1.469 39.58 34.64	1.478* 29.74 26.02	
452	HT-28			98	1600	1.0		S.F.V.	M β	.2396* 69.18	.2855* 58.08	.3078* 53.86	.3667 45.22	.3953 41.94	.4709 35.21	.5078 32.65	.6522 25.42	
453	HT-30			98	1600	1.0		Webull	β q		.7102* 71.59 60.96	.7782* 64.61 54.68	.5409* 50.19 43.25	.6295* 45.31 38.83	.7440 35.65 30.27	.7720 32.12 27.20	.7720* 22.65 19.18	
454	HT-29			98	1650	1.0		S.F.V.	M β	.3098* 72.74	.3809* 59.16	.4401* 51.21	.4683* 48.12	.5411 41.65	.5758 39.14	.6653 33.87	.7079 31.83	.8704* 25.89
455	HT-30			98	1650	1.0		S.F.V.	M β	.1343* 66.82	.1610* 55.73	.1741 51.54	.2088 42.98	.2257 39.75	.2707 33.15	.2927 30.66	.3795* 23.65	

HT-28: 1200°C, 1.5 hrs., 1080°C, 6.5 hrs., A.C., 700°C, 16 hrs., A.C.

HT-29: Forged 2150°F, 1 hr., O.Q.; Aged 1325°F 16 hrs., A.C.

HT-30: 1150°C, 4 hrs., A.C., 1080°C, 8 hrs., A.C.; 700°C 16 hrs, A.C.

Composition: See Page 169  
 (\*) Extrapolated Values

NIMONIC - 95 (Cont'd)

S<sub>u</sub> = 44-87 ksi  
 S<sub>y</sub> = 35-76 ksi

Code No.	TEST CONDITIONS						FATIGUE STRENGTH DISTRIBUTIONS AND THEIR PARAMETERS							
	Heat Treat	Surf. Fin.	Freq.	Temp	R <sub>r</sub>	Other	LIFE IN CYCLES							
							1x10 <sup>3</sup>	1x10 <sup>4</sup>	5x10 <sup>4</sup>	1x10 <sup>5</sup>	5x10 <sup>5</sup>	1x10 <sup>6</sup>	5x10 <sup>6</sup>	1x10 <sup>7</sup>

AXIAL (Completely Reversed)  
 Effect of Test Temperature

Code No.	Heat Treat	Surf. Fin.	Freq.	Temp	R <sub>r</sub>	Other	Dist.	Param	1x10 <sup>3</sup>	1x10 <sup>4</sup>	5x10 <sup>4</sup>	1x10 <sup>5</sup>	5x10 <sup>5</sup>	1x10 <sup>6</sup>	5x10 <sup>6</sup>	1x10 <sup>7</sup>	1x10 <sup>8</sup>
456	HT-28		98	1560	1.0		S.F.V.	β	.2939* 83.70	.3678* 66.87	.4304* 57.16	.4605* 53.42	.5387 45.66	.5764 42.68	.6743 36.48	.7215 34.09	.9031* 27.24
457	HT-28		98	1600	1.0		S.F.V.	β	.2396* 69.18	.2855* 58.08	.3078* 53.86	.3667 45.22	.3953 41.94	.4709 35.21	.5078 32.65	.5078 32.65	.6522 25.42
458	HT-30		98	1560	1.0		Webull	β		1.559* 76.40	1.520* 70.09	1.614* 57.43	1.796* 52.76	1.490 43.13	1.469 39.58	1.478* 29.74	1.478* 29.74
459	HT-30		98	1600	1.0		Webull	β		.7102* 71.59	.7782* 64.61	.5409* 50.19	.6295* 45.31	.7440 35.65	.7720 32.12	.7720* 22.65	.7720* 22.65
460	HT-30		98	1650	1.0		S.F.V.	β	.1036* 86.63	.1343* 66.82	.1610* 55.73	.1741 51.54	.2088 42.98	.2257 39.75	.2707 33.15	.2927 30.66	.3795* 23.65
461	HT-30		98	1740	1.0		Webull	β	1.219* 64.07	1.280* 50.81	1.280* 43.19	1.280* 40.27	1.280 34.22	1.269 31.91	1.130 27.08	1.310 25.29	1.160* 20.01
								β	53.99	42.59	36.20	33.75	28.68	26.77	22.99	21.15	16.95



RENE - 41 (AMS-5713)  
Composition: See Page 169  
(\* ) Extrapolated Values

S<sub>u</sub> = 182-197 ksi  
S<sub>y</sub> = 131-150 ksi

+Code No.	TEST CONDITIONS				FATIGUE STRENGTH DISTRIBUTIONS AND THEIR PARAMETERS								
	Heat Treat	Surf. Fin.	Temp. °F	R <sub>r</sub>	LIFE IN CYCLES								
					1x10 <sup>3</sup>	1x10 <sup>4</sup>	5x10 <sup>4</sup>	1x10 <sup>5</sup>	5x10 <sup>5</sup>	1x10 <sup>6</sup>	5x10 <sup>6</sup>	1x10 <sup>7</sup>	1x10 <sup>8</sup>
HT-31			80	1.0	3.691*	3.438*	3.438*	3.691	3.691	3.691	3.737	3.556*	3.647*
					175.9	143.7	124.7	117.4	101.9	95.93	83.29	78.35	64.01
					128.3	106.9	92.84	85.66	74.37	69.97	60.53	57.77	46.86

ROTARY BEAM BENDING  
Miscellaneous

Code No.	Heat Treat	Surf. Fin.	Temp. °F	R <sub>r</sub>	Dist.	Other	Other	Temp. °F	R <sub>r</sub>	Dist.	Other	Temp. °F	R <sub>r</sub>	Dist.	Other
462	HT-31		80	1.0	Webull										
					b	θ	X <sub>0</sub>	3.691*	3.438*	3.438*	3.691	3.691	3.691	3.737	3.556*
								175.9	143.7	124.7	117.4	101.9	95.93	83.29	78.35
								128.3	106.9	92.84	85.66	74.37	69.97	60.53	57.77

PLATE BENDING (Completely Reversed)  
Effect of Test Temperature

Code No.	Heat Treat	Surf. Fin.	Temp. °F	R <sub>r</sub>	Dist.	Other	Temp. °F	R <sub>r</sub>	Dist.	Other	Temp. °F	R <sub>r</sub>	Dist.	Other
463	HT-32	Milled	700	1.0	Webull									
					b	θ	X <sub>0</sub>	3.183*	3.202*	3.154*	3.102	3.091	3.091	3.091
								123.3	86.98	68.12	48.02	43.22	33.86	30.47
								65.78	46.21	36.53	26.01	23.46	18.38	16.54
464	HT-32	Milled	1400	1.0	Normal									
					b	θ	X <sub>0</sub>	16.51*	12.77*	10.67	8.257	7.643	6.387	5.912
								72.28	55.91	46.72	36.14	33.45	27.95	25.87

Miscellaneous

Code No.	Heat Treat	Surf. Fin.	Temp. °F	R <sub>r</sub>	Dist.	Other	Temp. °F	R <sub>r</sub>	Dist.	Other	Temp. °F	R <sub>r</sub>	Dist.	Other
465	HT-32	Milled	80	7.0	Webull									
					b	θ	X <sub>0</sub>	3.299*	3.446*	3.229*	3.447	3.447	3.446	3.446
								127.3	93.76	75.64	55.68	50.77	40.97	37.36
								90.47	65.70	54.06	39.01	35.57	28.71	26.18

HT-31: 1975°F, 1 hr., O.Q., 1650°F, 4 hrs., A.C.  
HT-32: 1950°F, 0.5 hr., A.C.; 1400°F, 16 hrs., A.C., Hot Rolled  
HT-33: 1975°F, W.Q., 1400°F, 16 hrs., A.C. (Vacuum melted and Hot Rolled)

RENE - 41 (AMS-5713) (Cont'd)

Composition: See Page 169  
(\* Extrapolated Values)

S<sub>u</sub> = 182-197 ksi  
S<sub>y</sub> = 131-150 ksi

4-Code No.	TEST CONDITIONS				FATIGUE STRENGTH DISTRIBUTIONS AND THEIR PARAMETERS													
	Heat Treat	Surf. Fin.	Freq.	Temp	R <sub>r</sub>	Other	DIST.	σ	n	LIFE IN CYCLES								
										1x10 <sup>3</sup>	1x10 <sup>4</sup>	5x10 <sup>4</sup>	1x10 <sup>5</sup>	5x10 <sup>5</sup>	1x10 <sup>6</sup>	5x10 <sup>6</sup>	1x10 <sup>7</sup>	1x10 <sup>8</sup>

AXIAL (Completely Reversed)  
Miscellaneous

466	HT-33	MP	16 RMS	80	1.0		Normal	σ	n	4.592*	3.991*	3.618	3.468	3.144	3.014	2.732*	2.619*	2.276*
										136.6	118.7	107.6	103.2	93.59	89.72	81.34	77.97	67.77

S<sub>u</sub> = 105 ksi  
S<sub>y</sub> = 81 ksi

NIMONIC - 80A

Composition: See Page 169  
(\* Extrapolated Values)

AXIAL (Completely Reversed)  
Miscellaneous

4-Code No.	Heat Treat	Surf. Fin.	Freq.	Temp	R <sub>r</sub>	Other	DIST.	σ	n	S.T.V.				Weibull				
										β	M	q	α	β	θ	X <sub>0</sub>	σ	
467			98	1380	1.0					.2041*	.2280*	.2463	.2547	.2751	.2845	.3073	.3177	.3549*
										69.89	62.57	57.92	56.02	51.85	50.15	46.42	44.90	40.20
468			98	1500	1.0					2.852*	2.852	2.852	2.852	2.852	2.852	2.852	2.852	2.852*
										49.99	46.64	44.43	43.51	41.45	40.59	38.67	37.87	35.33
										21.99	20.52	19.54	19.14	18.23	17.86	17.01	16.66	15.54
469	Annealed		98	1600	1.0					2.954*	2.954*	2.954	2.954	2.954	2.828	2.828	2.954	2.954
										61.73	50.68	44.15	41.60	36.24	34.14	29.74	28.04	23.01
										36.26	29.77	25.93	24.44	21.29	20.51	17.87	16.47	13.52

S<sub>u</sub> = 183-188 ksi  
 S<sub>y</sub> = 111-147 ksi

UDIMET - 500

Composition: See Page 169  
 (\*) Extrapolated Values

Code No.	TEST CONDITIONS			FATIGUE STRENGTH DISTRIBUTIONS AND THEIR PARAMETERS												
	Heat Treat	Surt. Fin.	Freq. M	K <sub>t</sub>	Other	DIST.	Param.	LIFE IN CYCLES								
								1x10 <sup>3</sup>	1x10 <sup>4</sup>	5x10 <sup>4</sup>	1x10 <sup>5</sup>	5x10 <sup>5</sup>	1x10 <sup>6</sup>	5x10 <sup>6</sup>	1x10 <sup>7</sup>	1x10 <sup>8</sup>

ROTARY BEAM BENDING  
 Miscellaneous

Code No.	Heat Treat	Surt. Fin.	Freq.	K <sub>t</sub>	Other	DIST.	Param.	1x10 <sup>3</sup>	1x10 <sup>4</sup>	5x10 <sup>4</sup>	1x10 <sup>5</sup>	5x10 <sup>5</sup>	1x10 <sup>6</sup>	5x10 <sup>6</sup>	1x10 <sup>7</sup>	1x10 <sup>8</sup>
470	HT-34		183	80	1.0	Normal	n <sub>0</sub>	9.187* 170.7	6.621* 123.0	5.266* 97.89	4.771* 88.70	3.795 70.55	3.439 63.92	2.735 50.84	2.478 46.07	1.786* 33.20

PLATE BENDING (Completely Reversed)  
 Effect of Coating

Code No.	Heat Treat	Surt. Fin.	Freq.	K <sub>t</sub>	Other	DIST.	Param.	1x10 <sup>3</sup>	1x10 <sup>4</sup>	5x10 <sup>4</sup>	1x10 <sup>5</sup>	5x10 <sup>5</sup>	1x10 <sup>6</sup>	5x10 <sup>6</sup>	1x10 <sup>7</sup>	1x10 <sup>8</sup>
471	HT-35		30	1800	1.0	Normal	n <sub>0</sub>	6.965* 51.96	5.296* 39.51	4.373 32.62	4.027 30.04	3.325 24.80	3.062 22.84	2.528 18.86	2.328 17.37	1.770* 13.20
472	HT-35		30	1800	1.0	Chrome Plated	n <sub>0</sub>	2.412* 49.20	2.412 36.15	2.412 29.14	2.706 26.57	2.414 21.41	2.711 19.52	2.496 15.73	2.417 14.33	2.606* 10.53
473	HT-35		30	1800	1.0	Alumt-Plated	n <sub>0</sub>	42.81 45.57	31.45 33.25	25.35 26.97	22.81 24.63	18.63 19.92	16.75 18.16	13.63 14.65	12.47 13.24	9.088 9.824

HT-34: Normalized 1350°F, 45 min. Hard. 1700F, 45 min. O.Q., Tempered 600°F, 1.5 hrs., SR 600°F, 1.5 hrs.

HT-35: 2100°F, 4 hrs., A.C., 1975°F, 4 hrs., A.C., 1400°F, 16 hrs., A.C.

HT-36: Sol. H.T., 1975°F, 4 hrs., A.C., Aged 1550°F, 24 hrs., A.C.; Aged 1400°F, 16 hrs., A.C.

S<sub>u</sub> = 183-188 ksi  
 S<sub>y</sub> = 111-147 ksi

UDIMET - 500 (Cont'd)

Composition: See Page i69  
 (\*) Extrapolated Values

Code No.	TEST CONDITIONS				FATIGUE STRENGTH DISTRIBUTIONS AND THEIR PARAMETERS											
	Heat Treat	Surf. Fin.	Freq.	Temp.	R <sub>r</sub>	Other	DISG.	Part B	LIFE IN CYCLES							
									1x10 <sup>3</sup>	1x10 <sup>4</sup>	5x10 <sup>4</sup>	1x10 <sup>5</sup>	5x10 <sup>5</sup>	1x10 <sup>6</sup>	5x10 <sup>6</sup>	1x10 <sup>7</sup>

PLATE BENDING (Completely Reversed)  
 Effect of Frequency

474	HT-35		30	1800	1.0			Normal	8	6.965*	5 296*	4.373	4.027	3.325	3.062	2.528	2.328	1.770*
										51.96	39.51	32.62	30.04	24.80	22.84	18.86	17.37	13.20
475	HT-35		132	1800	1.0			S.F.V.	8	.1784*	.2348*	.2845	.3090	.3744	.4067	.4928	.5352	.7044*
										54.91	41.72	34.43	31.70	26.16	24.09	19.88	18.30	13.90

672

Effect of Test Temperature

476	HT-36		132	1600	1.0			L.F.V.	8	.1980*	.2353*	.2654*	.2795	.3153	.3321	.3746	.3946	.4688*
										75.58	63.61	56.39	53.54	47.46	45.06	39.95	37.93	31.92
477	HT-36		132	80	1.0			S.F.V.	8	.1015*	.1238*	.1422*	.1510*	.1734	.1841	.2115	.2245	.2737*
										108.6	89.09	77.56	73.07	63.61	59.92	52.16	49.14	40.30
478	HT-35		132	1800	1.0			S.F.V.	8	.1784*	.2348*	.2845	.3090	.3744	.4067	.4928	.5352	.7044*
										54.91	41.72	34.43	31.70	26.16	24.09	19.88	18.30	13.90
479	HT-35		132	1200	1.0			Wet Bull	8	1.125*	1.078*	1.000*	1.094	.9916	1.024	1.088	1.111	1.175*
										90.62	74.30	64.63	60.99	53.03	49.99	43.58	41.07	33.74
										71.91	59.24	51.89	48.54	42.61	40.05	34.71	32.64	26.63

HT-37: Sol. H.T., 1975°F, 4 hrs., 0.0. Aged 1550°F, 24 hrs., A.C., Aged 1400°F, 16 hrs., A.C.

UDIMET - 500 (Cont'd)  
 Composition: See Page 169  
 (\*) Extrapolated Values

S<sub>u</sub> = 183-188 ksi  
 S<sub>y</sub> = 111-147 ksi

Code No.	TEST CONDITIONS			FATIGUE STRENGTH DISTRIBUTIONS AND THEIR PARAMETERS														
	Heat Treat	Surt.	Fin.	Freq.	Temp	R <sub>r</sub>	Other	DIST.	Param.	LIFE IN CYCLES								
										1x10 <sup>3</sup>	1x10 <sup>4</sup>	5x10 <sup>4</sup>	1x10 <sup>5</sup>	5x10 <sup>5</sup>	1x10 <sup>6</sup>	5x10 <sup>6</sup>	1x10 <sup>7</sup>	1x10 <sup>8</sup>

AXIAL (Completely Reversed)  
 Miscellaneous

480	HT-37			60	1650	1.0		Webull	σ <sub>q</sub>	1.104*	1.435*	1.385*	1.364*	1.319	1.303	1.303	1.303	1.303*
										64.76	55.50	49.71	47.41	42.48	40.51	36.31	34.63	29.60
										58.56	49.34	44.32	42.32	38.01	36.28	32.51	31.01	26.51

S<sub>u</sub> = 209 ksi  
 S<sub>y</sub> = 181 ksi

UDIMET - 650  
 Composition: See Page 169  
 (\*) Extrapolated Values

ROTARY BEAM BENDING  
 Miscellaneous

481	HT-38	Machined			80	1.0	Vacuum	L.E.V.	σ <sub>q</sub>	.1173*	.1433	.1563	.1910	.2082	.2544*	.2773*	.3695*
										136.3	111.5	102.3	83.76	76.83	62.87	57.67	43.29

HT-38: 1950°F, 1 hr., A.C., 1400°F, 10 hrs., F.C. to 1200°F and hold for 10 hrs.

Composition: See Page 169  
 (\*) Extrapolated Values

6 Mo - WASPALLOY

$S_u = 156 \text{ ksi}$   
 $S_y = 96 \text{ ksi}$

Code No.	TEST CONDITIONS						FATIGUE STRENGTH DISTRIBUTIONS AND THEIR PARAMETERS									
	Heat Treat	Surf. Fin.	Freq.	Temp °F	K <sub>t</sub>	Other	DIST.	Param.	LIFE IN CYCLES							
									1x10 <sup>3</sup>	1x10 <sup>4</sup>	5x10 <sup>4</sup>	1x10 <sup>5</sup>	5x10 <sup>5</sup>	1x10 <sup>6</sup>	5x10 <sup>6</sup>	1x10 <sup>7</sup>

AXIAL (Completely Reversed)  
 Effect of Stress Concentration

Code No.	Heat Treat	Surf. Fin.	Freq.	Temp °F	K <sub>t</sub>	Other	DIST.	Param.	1x10 <sup>3</sup>	1x10 <sup>4</sup>	5x10 <sup>4</sup>	1x10 <sup>5</sup>	5x10 <sup>5</sup>	1x10 <sup>6</sup>	5x10 <sup>6</sup>	1x10 <sup>7</sup>	1x10 <sup>8</sup>
482	HT-39	Lapped - 10 RMS	60	80	2.4	Hot Rolled	Wetbull	M	.2179* 78.29	.2734* 62.41	.3203* 53.26	.3429* 49.75	.4018 42.46	.4302 39.66	.5041 33.85	.5397 31.61	.6770* 25.20
483	HT-39	Lapped - 10 RMS	60	80	3.4	Hot Rolled	Wetbull	q	5.824* 77.37 45.97	5.747* 59.53 35.65	5.671 49.56 29.91	5.602 45.80 27.83	5.462 38.13 23.49	5.408 35.23 21.82	5.017 29.33 18.86	4.881 27.10 17.65	4.608* 20.85 13.92
484	HT-39	Lapped - 10 RMS	60	1500	2.4	Hot Rolled	Wetbull	q	2.911* 32.97 28.52	2.841* 30.46 26.43	2.795 28.83 25.05	2.776 28.15 24.48	2.733 26.64 23.21	2.715 26.02 22.68	2.675 24.62 21.50	2.658 24.04 21.00	3.064* 22.23 19.11
485	HT-39	Lapped - 10 RMS	60	1500	3.4	Hot Rolled	Wetbull	q	2.221* 30.27 26.01	2.148* 27.85 24.03	2.100 26.28 22.73	2.080 25.62 22.19	2.035 24.17 20.98	2.016 23.58 20.48	1.975 22.24 19.36	1.957 21.69 18.90	2.084* 19.97 17.28

Effect of Test Temperature

Code No.	Heat Treat	Surf. Fin.	Freq.	Temp °F	K <sub>t</sub>	Other	DIST.	Param.	1x10 <sup>3</sup>	1x10 <sup>4</sup>	5x10 <sup>4</sup>	1x10 <sup>5</sup>	5x10 <sup>5</sup>	1x10 <sup>6</sup>	5x10 <sup>6</sup>	1x10 <sup>7</sup>	1x10 <sup>8</sup>
486	HT-39	Lapped - 10 RMS	60	80	3.4	Hot Rolled	Wetbull	q	5.824* 77.37 45.97	5.747* 59.53 35.65	5.671 49.56 29.91	5.602 45.80 27.83	5.462 38.13 23.49	5.408 35.23 21.82	5.017 29.33 18.86	4.881 27.10 17.65	4.608* 20.85 13.92
487	HT-39	Lapped - 10 RMS	60	1500	3.4	Hot Rolled	Wetbull	q	2.221* 30.27 26.01	2.148* 27.85 24.03	2.100 26.28 22.73	2.080 25.62 22.19	2.035 24.17 20.98	2.016 23.58 20.48	1.975 22.24 19.36	1.957 21.69 18.90	2.084* 19.97 17.28

Composition: See Page 169  
 (\*) Extrapolated Values

6 Mo - WASPALLOY (Cont'd)

S<sub>u</sub> = 156 ksi  
 S<sub>y</sub> = 96 ksi

Code No.	TEST CONDITIONS				Other	DIST.	Param.	FATIGUE STRENGTH DISTRIBUTIONS AND THEIR PARAMETERS							
	Heat Treat	Surf. Fin.	Freq.	Temp.				LIFE IN CYCLES							
								HT-39	HT-39	HT-39	HT-39	HT-39	HT-39	HT-39	HT-39

AXIAL (Completely Reversed)  
 Effect of Test Temperature

Code No.	Heat Treat	Surf. Fin.	Freq.	Temp.	Other	DIST.	Param.	1x10 <sup>3</sup>	1x10 <sup>4</sup>	5x10 <sup>4</sup>	1x10 <sup>5</sup>	5x10 <sup>5</sup>	1x10 <sup>6</sup>	5x10 <sup>6</sup>	1x10 <sup>7</sup>	1x10 <sup>8</sup>
488	HT-39	Mechanical Polish	60	80		Wetbull	b	1.488*	1.047*	1.488	1.369	1.488	1.072	.8028	1.118	.6630*
							σ	122.1	103.1	91.98	87.43	77.84	73.87	65.61	62.53	52.75
							σ <sub>p</sub>	116.0	99.19	87.41	83.36	73.97	70.99	63.46	60.02	51.14
489	HT-39		60	1200		Wetbull	b	1.684*	1.684	1.684	1.684	1.671	1.684	1.647	1.600*	1.664*
							σ	78.06	71.45	67.17	65.41	61.48	59.87	56.27	54.79	50.16
							σ <sub>p</sub>	67.95	62.20	58.48	56.94	53.56	52.12	49.09	47.92	43.72
490	HT-39		60	1500		L.E.V.	β	.8666*	.9308*	.9785*	.9998*	1.050	1.073	1.128	1.153	1.238*
							M	52.97	49.32	46.92	45.92	43.69	42.76	40.67	39.81	37.06
491	HT-39		60	80		S.E.V.	β	.2179*	.2734*	.3203*	.3429*	.4018	.4302	.5041	.5397	.6770*
							M	78.29	62.41	53.26	49.75	42.46	39.66	33.85	31.61	25.20
492	HT-39		60	1200		L.E.V.	β	.3861*	.4291*	.4619	.4768	.5134	.5299	.5705	.5889	.6545*
							M	42.42	38.17	35.46	34.35	31.91	30.91	28.71	27.81	25.03
493	HT-39		60	1500		Wetbull	b	2.911*	2.841*	2.795	2.776	2.733	2.715	2.675	2.658	3.064*
							σ	32.97	30.46	28.83	28.15	26.64	26.02	24.62	24.04	22.23
							σ <sub>p</sub>	28.52	26.43	25.05	24.48	23.21	22.68	21.50	21.00	19.11

HT-39: Sol. H.T. 1975°F, 4 hrs, A.C. Aged 1550°F, 24 hrs., A.C., Aged 1400°F 16 hrs, A.C.

A-1.5.6 Titanium Alloys



Composition: See Page 170  
 (\*) Extrapolated Values

COMMERCIALY PURE TITANIUM  
 (TI-A55)

S<sub>u</sub> = 70-120 ksi  
 S<sub>y</sub> = 57-65 ksi

+Code No.	TEST CONDITIONS				FATIGUE STRENGTH DISTRIBUTIONS AND THEIR PARAMETERS												
	Heat Treat	Surf. Fin.	Freq.	Temp.	K <sub>t</sub>	Other	DIST.	Param.	LIFE IN CYCLES								
									1x10 <sup>3</sup>	1x10 <sup>4</sup>	5x10 <sup>4</sup>	1x10 <sup>5</sup>	5x10 <sup>5</sup>	1x10 <sup>6</sup>	5x10 <sup>6</sup>	1x10 <sup>7</sup>	1x10 <sup>8</sup>

ROTARY BEAM BENDING  
 Effect of Frequency

+Code No.	Cold drawn and Annealed		S <sub>u</sub>	S <sub>y</sub>	K <sub>t</sub>	Other	DIST.	Param.	LIFE IN CYCLES								
	σ	n							4.073	3.677	3.519	3.177	3.041	2.745*	2.627*		
494	4.714*	93.03	80.38	72.58	69.46	62.71	60.01	54.188	51.85								
495	1.941*	102.8	84.96	74.36	70.21	61.45	58.02	50.78	47.95	1.941	1.941	1.941	1.941*	1.941*	1.941*	1.941*	1.941*
496	.3653	76.03	37.81	23.20	18.80	11.54	9.353	5.740	4.651	1.197*	2.407*	2.970*	4.840*	5.972*			
497	.1947*	71.15	48.52	37.13	33.08	25.31	22.56	17.26	15.38	.3732	.5473	.6142	.8026*	.9007			

Effect of Impurities

+Code No.	Vacuum Annealed 1 hr. at 1500°F		Mechanical Polish - 8 RMS		Temp.	K <sub>t</sub>	Other	DIST.	Param.	LIFE IN CYCLES							
	σ	n	σ	n						3.174	.3457	.3906	.4052*				
498	.2486*	76.20	67.44	61.92	59.69	54.81	52.83	48.51	46.76								
499	7.005*	74.85	69.40	65.83	64.34	61.03	59.66	56.59	55.32	6.947*	6.856	6.844	6.810*	6.795*			
	43.85	40.87	38.89	38.07	38.07	36.23	35.46	33.73	33.01								

Composition: See Page 170  
 (\*) Extrapolated Values

COMMERCIALY PURE TITANIUM (Cont'd)  
 (Ti-A55)

S<sub>u</sub> = 70-120 ksi  
 S<sub>y</sub> = 57-65 ksi

Code No.	TEST CONDITIONS				FATIGUE STRENGTH DISTRIBUTIONS AND THEIR PARAMETERS												
	Heat Treat	Surf. Fin.	Freq.	Temp °K	K <sub>t</sub>	Other	DIST.	Param.	LIFE IN CYCLES								
									1x10 <sup>3</sup>	1x10 <sup>4</sup>	5x10 <sup>4</sup>	1x10 <sup>5</sup>	5x10 <sup>5</sup>	1x10 <sup>6</sup>	5x10 <sup>6</sup>	1x10 <sup>7</sup>	1x10 <sup>8</sup>

ROTARY BEAM BENDING  
 Effect of Impurities

500	Vacuum annealed 1 hr. at 1500 °F	Mechanical Polish-8 RMS	167	80	3.0	H <sub>2</sub> 18 ppm	Webull	σ <sub>s</sub>	1.127*	.9784*	1.514	1.514	1.130	1.020	.7489*	.8576*	
501							Webull	σ <sub>s</sub>	52.52	42.26	36.66	34.36	29.41	27.52	23.58	22.14	
								σ <sub>s</sub>	46.17	37.59	31.13	29.18	25.85	24.40	21.27	19.85	
								σ <sub>s</sub>	2.266*	2.158*	2.360	2.337	2.288	2.269	2.265*	2.265*	
								σ <sub>s</sub>	61.68	49.18	42.01	39.24	33.50	31.29	26.71	24.95	
								σ <sub>s</sub>	50.18	40.31	33.94	31.76	27.71	25.45	21.73	20.30	

Effect of Stress Concentration

502			30	80	1.0		Normal	r <sub>s</sub>	4.714*	4.073	3.677	3.519	3.177	3.041	2.745*	2.627*	
								r <sub>s</sub>	93.03	80.38	72.58	69.46	62.71	60.01	54.188	51.85	
503			30	80	1.8		Normal	r <sub>s</sub>	5.060*	3.683	2.949	2.680	2.146	1.950*	1.562*	1.419*	
								r <sub>s</sub>	89.50	65.13	52.16	47.40	37.96	34.50	27.63	25.11	
504			30	80	2.5		Webull	σ <sub>s</sub>	3.196*	3.145	3.196	3.196	3.196	3.196	3.156*	3.177*	
								σ <sub>s</sub>	80.92	56.45	43.89	39.38	30.62	27.47	21.36	19.16	
								σ <sub>s</sub>	54.37	38.14	29.49	26.46	20.57	18.46	14.41	12.90	

Composition: See Page 170  
 (\*) Extrapolated Values

COMMERCIALY PURE TITANIUM (Cont'd)  
 (Ti-A55)

S<sub>y</sub> = 70-120 ksi  
 S<sub>u</sub> = 57-65 ksi

Code No.	TEST CONDITIONS				FATIGUE STRENGTH DISTRIBUTIONS AND THEIR PARAMETERS													
	Heat Treat	Surf. Fin.	Freq.	Temp	K <sub>t</sub>	Other	DISTR.	PARAM.	LIFE IN CYCLES									
									1x10 <sup>3</sup>	1x10 <sup>4</sup>	5x10 <sup>4</sup>	1x10 <sup>5</sup>	5x10 <sup>5</sup>	1x10 <sup>6</sup>	5x10 <sup>6</sup>	1x10 <sup>7</sup>	1x10 <sup>8</sup>	
505			30	80	3.5		S.F.V.	β	.3653 76.03	.7346 37.81	1.197* 23.20	1.477* 18.80	2.407* 11.54	2.970* 9.353	4.840* 5.740	5.972* 4.651		
506			30	80	4.7		S.F.V.	β	.1251* 68.42	.1889 45.32	.2520 33.98	.2853 30.02	.3804 22.51	.4307* 19.88	.5744* 14.91	.6502* 13.17		
507			15	80	1.0		Weldball	b θ X <sup>o</sup>	1.941* 102.8 85.27	1.941 84.96 70.46	1.941 74.36 61.68	1.941 70.21 58.23	1.941 61.45 50.97	1.941 58.02 48.12	1.941* 50.78 42.12	1.941* 47.95 39.77		
508			15	80	3.5		L.F.V.	β	.1947* 71.15	.2856 48.52	.3732 37.13	.4188 33.08	.5473 25.31	.6142 22.56	.8026* 17.26	.9007* 15.38		
509			167	80	1.0		S.F.V.	β	.1800* 92.05	.2169 76.38	.2472 67.04	.2614 63.37	.2979 55.62	.3151 52.58	.3590 46.15	.3798* 43.63		
510			167	80	3.5		Normal	σ	11.00 72.63	8.309 54.82	6.825 45.03	6.271 41.37	5.151 33.99	4.733 31.23	3.888 25.65	3.572 23.57		

ROTARY BEAM BENDING  
 Effect of Stress Concentration

Composition: See Page 170  
 (\*) Extrapolated Values

COMMERCIALY PURE TITANIUM (Cont'd)  
 (TI-A55)

S<sub>u</sub> = 70-120 ksi  
 S<sub>y</sub> = 57-65 ksi

+Code No.	TEST CONDITIONS				FATIGUE STRENGTH DISTRIBUTIONS AND THEIR PARAMETERS												
	Heat Treat	Surf. Fin.	Freq.	Temp	K <sub>t</sub>	Other	DIST.	Param.	LIFE IN CYCLES								
									1x10 <sup>3</sup>	1x10 <sup>4</sup>	5x10 <sup>4</sup>	1x10 <sup>5</sup>	5x10 <sup>5</sup>	1x10 <sup>6</sup>	5x10 <sup>6</sup>	1x10 <sup>7</sup>	1x10 <sup>8</sup>

ROTARY BEAM BENDING  
 Effect of Stress Concentration

	Vacuum Annealed at 1500 °F		Mechanical Polishing-8 RMS															
514	390 ppm Hydrogen	Webull	Webull	Webull	S.F.V.	Webull	Webull	S.F.V.	β	M	β	M	β	M	β	M	β	M
513	18 ppm Hydrogen	Webull	Webull	Webull	S.F.V.	Webull	Webull	S.F.V.	β	M	β	M	β	M	β	M	β	M
512		Webull	Webull	Webull	S.F.V.	Webull	Webull	S.F.V.	β	M	β	M	β	M	β	M	β	M
511		Webull	Webull	Webull	S.F.V.	Webull	Webull	S.F.V.	β	M	β	M	β	M	β	M	β	M

Composition: See Page 170  
 (\*) Extrapolated Values

T1 - 75A

S<sub>u</sub> = 86-107 ksi  
 S<sub>y</sub> = 65-88 ksi

+Code No.	TEST CONDITIONS				FATIGUE STRENGTH DISTRIBUTIONS AND THEIR PARAMETERS												
	Heat Treat	Surf. Fin.	Freq.	Temp.	R <sub>r</sub>	Other	DIST.	Param.	LIFE IN CYCLES								
									1x10 <sup>3</sup>	1x10 <sup>4</sup>	5x10 <sup>4</sup>	1x10 <sup>5</sup>	5x10 <sup>5</sup>	1x10 <sup>6</sup>	5x10 <sup>6</sup>	1x10 <sup>7</sup>	1x10 <sup>8</sup>

ROTARY BEAM BENDING

Effect of Surface Finish

+Code No.	Heat Treat	S <sub>u</sub>	S <sub>y</sub>	Temp.	R <sub>r</sub>	Other	DIST.	Param.	LIFE IN CYCLES							
									1x10 <sup>3</sup>	1x10 <sup>4</sup>	5x10 <sup>4</sup>	1x10 <sup>5</sup>	5x10 <sup>5</sup>	1x10 <sup>6</sup>	5x10 <sup>6</sup>	1x10 <sup>7</sup>
515	Annealed	86-107	65-88	80	2.4	V	Notch	Webull	4.909*	4.909*	4.909*	4.906	4.916	4.704	4.884*	4.741*
									43.39	34.55	29.47	27.51	23.46	21.91	18.68	17.44
516	Diamond Ground	86-107	65-88	80	3.2	V	Notch	S.E.V.	.2077*	.2814*	.3479	.3812	.4712	.5163	.6383*	.6994*
									52.04	38.42	31.07	28.36	22.94	20.93	16.93	15.45
517	Surface Rolled	86-107	65-88	80	2.4	V	Notch	Webull	1.786*	1.786*	1.786	1.786	2.273	2.233	2.142*	2.105*
									84.08	75.17	69.50	67.20	62.18	60.11	55.58	53.73
518	S.R. & D. Ground	86-107	65-88	80	2.4	LTB	S.E.V.	Webull	.3816*	.5038*	.6117	.6650	.8074	.8778	.1065*	1.158*
									55.71	42.20	34.76	31.97	26.33	24.22	19.94	18.35
519	Machined	86-107	65-88	80	2.4	Radius	Notch	Webull	1.359*	1.570*	1.629	1.651	1.692	1.705	1.651	1.629*
									58.80	55.01	52.49	51.44	49.08	48.10	45.88	44.96
520	Annealed	86-107	65-88	167	1.0	LTB	Normal	Webull	4.424*	3.795	3.409	3.255	2.924	2.792	2.508*	2.394*
									70.72	60.66	54.49	52.03	46.73	44.62	40.08	38.27

Miscellaneous

+Code No.	Heat Treat	S <sub>u</sub>	S <sub>y</sub>	Temp.	R <sub>r</sub>	Other	DIST.	Param.	1x10 <sup>3</sup>	1x10 <sup>4</sup>	5x10 <sup>4</sup>	1x10 <sup>5</sup>	5x10 <sup>5</sup>	1x10 <sup>6</sup>	1x10 <sup>7</sup>	1x10 <sup>8</sup>
520	Annealed	86-107	65-88	167	1.0	LTB	Normal	Webull	4.424*	3.795	3.409	3.255	2.924	2.792	2.508*	2.394*
									70.72	60.66	54.49	52.03	46.73	44.62	40.08	38.27

S<sub>u</sub> = 86-107 ksi  
S<sub>y</sub> = 65-38 ksi

Ti - 75A (Cont'd)

Composition: See Page 170  
(\* ) Extrapolated Values

Code No.	TEST CONDITIONS				FATIGUE STRENGTH DISTRIBUTIONS AND THEIR PARAMETERS											
	Heat Treat	Surf. Fin.	Freq. %	Temp °F	K <sub>t</sub>	Other	DISTR.	Param.	LIFE IN CYCLES							
									1x10 <sup>3</sup>	1x10 <sup>4</sup>	5x10 <sup>4</sup>	1x10 <sup>5</sup>	5x10 <sup>5</sup>	1x10 <sup>6</sup>	5x10 <sup>6</sup>	1x10 <sup>7</sup>

ROTARY BEAM BENDING  
Effect of Frequency

Code No.	Heat Treat	Surf. Fin.	Freq. %	Temp °F	K <sub>t</sub>	Other	DISTR.	Param.	1x10 <sup>3</sup>	1x10 <sup>4</sup>	5x10 <sup>4</sup>	1x10 <sup>5</sup>	5x10 <sup>5</sup>	1x10 <sup>6</sup>	5x10 <sup>6</sup>	1x10 <sup>7</sup>	1x10 <sup>8</sup>
521	Annealed		6.66	80	1.0		Wetbulb	b X <sub>0</sub> q	1.590* 75.45 70.77	1.661 68.07 63.74	1.860 63.37 59.03	1.385 61.36 57.83	1.483 57.11 53.71	1.408 55.36 52.14	1.280* 51.50 48.63	1.429* 49.94 47.02	
522	Annealed		30	80	1.0		Wetbulb	b X <sub>0</sub> q	1.647* 76.33 73.89	1.398 64.14 62.27	1.464 56.81 55.12	1.564 53.92 52.25	1.741* 47.77 46.19	1.741* 45.34 43.83	1.241* 40.13 39.02	1.383* 38.09 36.98	
523	Annealed		167	80	1.0		L.E.V.	H M 8	.3759* 70.91	.4356 61.19	.4829 55.20	.5048 52.80	.5596 47.63	.5850* 45.56	.6485* 41.10	.6779* 39.32	

Effect of Stress Concentration

Code No.	Heat Treat	Surf. Fin.	Freq. %	Temp °F	K <sub>t</sub>	Other	DISTR.	Param.	100	80	2.8	2.4	100	80	2.8	2.4
524	Annealed		100	80	2.4	Notch	Wetbulb	b X <sub>0</sub> q	1.359* 58.80 54.86	1.570* 55.01 51.05	1.629 52.49 48.64	1.651 51.44 47.64	1.692 49.08 45.40	1.705 48.10 44.47	1.651 45.88 42.49	1.629* 44.96 41.66
525	Machined		100	80	2.8	Square Notch	Wetbulb	b X <sub>0</sub> q	8.255* 44.49 27.31	8.107* 35.82 22.21	8.019* 30.78 19.19	7.986 28.83 18.02	7.916 24.77 15.56	7.891 23.21 14.50	7.799* 19.94 12.62	7.555* 18.68 12.01
526	Annealed		100	80	3.2	Radius Notch	Wetbulb	b X <sub>0</sub> q	4.909* 43.39 30.65	4.909* 34.55 24.41	4.909* 29.47 20.81	4.906 27.51 19.44	4.916 23.46 16.57	4.704 21.91 15.70	4.884* 18.68 13.22	4.741* 17.44 12.47

Composition: See Page 170  
 (\*) Extrapolated Values

T1 - 150A

S<sub>u</sub> = 137 ksi  
 S<sub>y</sub> = 132 ksi

Code No.	TEST CONDITIONS				FATIGUE STRENGTH DISTRIBUTIONS AND THEIR PARAMETERS											
	Heat Treat	Surf. Fin.	Freq.	Temp	K <sub>t</sub>	Other	DIST. Param.	LIFE IN CYCLES								
								1x10 <sup>3</sup>	1x10 <sup>4</sup>	5x10 <sup>4</sup>	1x10 <sup>5</sup>	5x10 <sup>5</sup>	1x10 <sup>6</sup>	5x10 <sup>6</sup>	1x10 <sup>7</sup>	1x10 <sup>8</sup>

ROTARY BEAM BENDING  
 Effect of Stress Concentration

527	Ground	#46 Abrasive	80	1.0		Wetbulb	Wetbulb	4.638*	4.632*	72.48	44.16	4.431	4.632	4.431	4.805	4.391*
								80.12	75.53			71.19	68.33	67.12	64.43	63.27
								48.78	46.02			44.35	41.63	41.81	38.49	39.59
528			80	Notched		Wetbulb	Wetbulb	1.166*	1.253*	37.07	28.91	1.196	1.183	1.300*	1.206*	1.169*
								64.17	46.52			33.65	26.85	24.40	19.44	17.63
								50.04	35.91			26.15	20.89	18.72	15.09	13.74

062

Effect of Surface Finish

529	Ground		80	1.0		Wetbulb	Wetbulb	4.638*	4.632*	72.48	44.16	4.431	4.632	4.431	4.805	4.391*
								80.12	75.53			71.19	68.33	67.12	64.43	63.27
								48.78	46.02			44.35	41.63	41.81	38.49	39.59
530	M.P.		80	1.0		Wetbulb	Wetbulb	1.202*	1.332	98.62	88.25	1.301	1.456	1.502	.9018*	1.119*
								109.2	98.62			88.86	82.79	80.28	74.13	72.03
								98.46	88.25			79.65	73.53	71.10	67.73	65.20

Composition: See Page 170  
 (\*) Extrapolated Values

T1 - 0.2 O2

S<sub>u</sub> = 82 ksi  
 S<sub>y</sub> = 65 ksi

Code No.	TEST CONDITIONS				FATIGUE STRENGTH DISTRIBUTIONS AND THEIR PARAMETERS												
	Heat Treat	Surt. Fin.	Freq.	Temp	R <sub>r</sub>	Other	DIST.	Param.	LIFE IN CYCLES								
									1x10 <sup>3</sup>	1x10 <sup>4</sup>	5x10 <sup>4</sup>	1x10 <sup>5</sup>	5x10 <sup>5</sup>	1x10 <sup>6</sup>	5x10 <sup>6</sup>	1x10 <sup>7</sup>	1x10 <sup>8</sup>

ROTARY BEAM BENDING  
 Effect of Stress Concentration

Code No.	Heat Treat	Surt. Fin.	Freq.	Temp	R <sub>r</sub>	Other	DIST.	Param.	σ	τ	b	θ	X <sub>0</sub>	2.974	2.742	2.648	2.442	2.358	
531	1 hr. at 1400° F. A.C.	Mechanical & Electropolish		80	1.0		Normal	σ	3.751*	3.340*	3.080	2.974	2.742	2.648	2.442	2.358	2.358	51.10	
532				80	3.0		Wetbulb	τ	2.177*	2.107*	2.065	2.048	2.016	2.016	2.016	2.016	2.016	2.016	19.60
									81.29	72.38	66.74	64.45	59.43	57.38	52.91	51.10			
									52.54	43.29	37.81	35.67	31.16	29.40	25.68	24.23			
									41.98	34.78	30.48	28.79	25.21	23.79	20.78	19.60			

AXIAL (Completely Reversed)  
 Miscellaneous

Code No.	Heat Treat	Surt. Fin.	Freq.	Temp	R <sub>r</sub>	Other	DIST.	Param.	σ	τ	b	θ	X <sub>0</sub>	1.295	1.445	1.484	1.504*	1.463*
533	HT-40						Wetbulb	σ	1.299*	1.444*	.9408	1.295	1.445	1.484	1.504*	1.463*	1.504*	1.463*
								τ	58.45	51.37	46.84	45.10	41.22	39.65	36.22	34.82	36.22	34.82
								X <sub>0</sub>	54.78	47.94	44.25	42.27	38.47	36.96	33.74	32.48	33.74	32.48

HT-40: Vacuum Annealed at 1300°F



S<sub>y</sub> = 85 ksi  
 S<sub>u</sub> = 79 ksi

T1 - 0.2C

Composition: See Page 170  
 (\*) Extrapolated Values

Code No.	TEST CONDITIONS				FATIGUE STRENGTH DISTRIBUTIONS AND THEIR PARAMETERS												
	Heat Treat	Surf. Fin.	Freq.	Temp.	R <sub>r</sub>	Other	DIST.	Param.	LIFE IN CYCLES								
									1x10 <sup>3</sup>	1x10 <sup>4</sup>	5x10 <sup>4</sup>	1x10 <sup>5</sup>	5x10 <sup>5</sup>	1x10 <sup>6</sup>	5x10 <sup>6</sup>	1x10 <sup>7</sup>	1x10 <sup>8</sup>

ROTARY BEAM BENDING  
 Effect of Stress Concentration

534	1 hr. at 1400° F. A.C.	Mechanical & Electropolish	80	80	1.0		S.E.V.	M		.3285*	.3528	.3638	.3906	.4028	.4325	.4460	
										78.39	73.00	70.79	65.93	63.93	59.54	57.74	
535			80	80	3.0		Webull	Y	1.598*	1.419*	1.313	1.277	1.277	1.277	1.277*	1.277*	1.277*
									58.24	43.43	35.38	32.39	26.40	24.17	19.70	18.04	
									51.83	38.98	31.91	29.26	23.85	21.84	17.80	16.30	

AXIAL (Completely Reversed)  
 Miscellaneous

536	HT-40	Longt. Polish	80	80	1.0		Normal	Y	3.139*	2.374*	1.953	1.795	1.477*	1.358*	1.117*	1.027*	
									62.16	47.01	38.68	35.56	29.25	26.89	22.12	20.34	

Composition: See Page 170  
 (\*) Extrapolated Values

T1 - N2

S<sub>u</sub> = 81 ksi  
 S<sub>y</sub> = 69 ksi

Code No.	TEST CONDITIONS				FATIGUE STRENGTH DISTRIBUTIONS AND THEIR PARAMETERS											
	Heat Treat	Surf. Fin.	Req. Temp	K <sub>t</sub>	Other	DIST.	Param.	LIFE IN CYCLES								
								1x10 <sup>3</sup>	1x10 <sup>4</sup>	5x10 <sup>4</sup>	1x10 <sup>5</sup>	5x10 <sup>5</sup>	1x10 <sup>6</sup>	5x10 <sup>6</sup>	1x10 <sup>7</sup>	1x10 <sup>8</sup>

ROTARY BEAM BENDING  
 Miscellaneous

537	1400 °F 1 hr Ac.	M.P. & E.P.	80	3.0		S.E.V.	M β	.2437* 60.44	.3296* 44.70	.4070 36.20	.4457 33.05	.5504 26.77	.6027 24.44	.7443* 19.80	.8150* 18.08	
-----	---------------------	----------------	----	-----	--	--------	-----	-----------------	-----------------	----------------	----------------	----------------	----------------	-----------------	-----------------	--

AXIAL (Completely Reversed)  
 Miscellaneous

538	HT-10	Longl. Polish	80	1.0		Normal	h σ	3.585* 74.46	2.858* 59.36	2.440 50.67	2.279 47.33	1.945* 40.40	1.817* 37.73	1.551* 32.20	1.448* 30.08	
-----	-------	------------------	----	-----	--	--------	-----	-----------------	-----------------	----------------	----------------	-----------------	-----------------	-----------------	-----------------	--

S<sub>u</sub> = 121 ksi  
 S<sub>y</sub> = 116 ksi

Composition: See Page 170  
 (\*) Extrapolated Values

T1 - 0.07 N2 - 0.2 O2 - 0.2C

ROTARY BEAM BENDING  
 Effect of Stress Concentration

539	1 hr. at 1500° F. A.C.	Mechanical & Electropolish	80	1.0		S.E.V.	M β	.1425* 105.8	.1640* 91.95	.1809 83.35	.1887 79.90	.2081 72.43	.2171 69.44	.2395 62.95	.2499 60.34	
540			80	3.0		Weibull	q σ	1.097* 46.15 41.54	.8025* 39.93 36.68	.9563 36.38 33.07	.9927 34.92 31.67	.6682 31.45 29.12	.7211 30.21 27.89	.8154 27.49 25.23	.8482 26.39 24.17	

Composition: See Page 170  
 (\*) Extrapolated Values

**K - 151A TITANIUM BASE CERMET**

$S_u = 41.5 \text{ ksi @ } 1800^\circ\text{F}$

Code No.	TEST CONDITIONS				FATIGUE STRENGTH DISTRIBUTIONS AND THEIR PARAMETERS												
	Heat Treat	Surf. Fin.	Freq.	Temp	$R_r$	Other	DIST.	Param.	LIFE IN CYCLES								
									$1 \times 10^3$	$1 \times 10^4$	$5 \times 10^4$	$1 \times 10^5$	$5 \times 10^5$	$1 \times 10^6$	$5 \times 10^6$	$1 \times 10^7$	$1 \times 10^8$

PLATE BENDING (Completely Reversed)  
 Effect of Test Temperature

Code No.	Heat Treat	Surf. Fin.	Freq.	Temp	$R_r$	Other	DIST.	Param.	$1 \times 10^3$	$1 \times 10^4$	$5 \times 10^4$	$1 \times 10^5$	$5 \times 10^5$	$1 \times 10^6$	$5 \times 10^6$	$1 \times 10^7$	$1 \times 10^8$
541		Longitudinal		1800	1.0		Normal Weibull	$\sigma$	1.355	1.355	1.355	1.355	1.355	1.355	1.355	1.355	
		Ground						$\sigma$	60.68	51.56	48.07	40.84	38.08	32.36	30.17	30.17	
								$\sigma$	44.64	37.93	35.37	30.05	28.02	23.81	22.19	22.19	
542		Longitudinal		2000	1.0		Normal Weibull	$\sigma$	5.282	4.894	4.396	3.425	3.076	2.396	2.152	2.152	
		Ground						$\sigma$	40.23	31.35	28.15	21.93	19.70	15.34	13.78	13.78	

$S_u = 112 \text{ ksi}$

Composition: See Page 170  
 (\*) Extrapolated Values

**K - 162B TITANIUM BASE CERMET**

PLATE BENDING (Completely Reversed)  
 Effect of Test Temperature

Code No.	Heat Treat	Surf. Fin.	Freq.	Temp	$R_r$	Other	DIST.	Param.	$1 \times 10^3$	$1 \times 10^4$	$5 \times 10^4$	$1 \times 10^5$	$5 \times 10^5$	$1 \times 10^6$	$5 \times 10^6$	$1 \times 10^7$	$1 \times 10^8$
543		Longitudinal		1800	1.0		Normal Weibull	$\sigma$	6.946*	5.964	5.361	5.120	4.603	4.396	3.952	3.775	
		Ground						$\sigma$	54.89	47.12	42.36	40.46	36.37	34.74	31.23	29.83	
544		Longitudinal		2000	1.0		Weibull	$\sigma$	.7859*	.8187	.5674	.6719	.8081	.8497	.6292	.6797	
		Ground						$\sigma$	50.55	38.04	30.89	28.44	23.41	21.51	17.48	16.06	
								$\sigma$	43.91	32.93	27.28	24.94	20.28	18.56	15.38	14.08	

Composition: See Page 170  
 (\*) Extrapolated Values

K - 183A TITANIUM BASE CERMET

S<sub>u</sub> = 72 ksi @ 1800°F

Code No.	TEST CONDITIONS				FATIGUE STRENGTH DISTRIBUTIONS AND THEIR PARAMETERS												
	Heat Treat	Surf. Fin.	Freq.	Temp. °F	K <sup>c</sup>	Other	DISP.	Param.	LIFE IN CYCLES								
									1x10 <sup>3</sup>	1x10 <sup>4</sup>	5x10 <sup>4</sup>	1x10 <sup>5</sup>	5x10 <sup>5</sup>	1x10 <sup>6</sup>	5x10 <sup>6</sup>	1x10 <sup>7</sup>	1x10 <sup>8</sup>

PLATE BENDING (Completely Reversed)  
 Effect of Stress Concentration

Code No.	Heat Treat	Surf. Fin.	Freq.	Temp. °F	K <sup>c</sup>	Other	DISP.	Param.	1x10 <sup>3</sup>	1x10 <sup>4</sup>	5x10 <sup>4</sup>	1x10 <sup>5</sup>	5x10 <sup>5</sup>	1x10 <sup>6</sup>	5x10 <sup>6</sup>	1x10 <sup>7</sup>	1x10 <sup>8</sup>
545				2000	1.0		Wetbull	q	1.840*	1.840	1.840	1.840	1.840	1.840	1.840	1.840*	
							Wetbull	q	47.65	30.77	28.48	23.78	23.78	22.01	18.39	17.01	
							Wetbull	q	36.29	23.44	21.63	18.12	18.12	16.77	14.00	12.96	
546				2000	2.0		Wetbull	q	4.086*	4.004	3.961	3.871	3.871	3.837	3.766	3.739*	
							Wetbull	q	30.16	20.00	18.60	15.71	15.71	14.60	12.33	11.47	
							Wetbull	q	18.12	12.15	11.36	9.710	9.710	9.059	7.728	7.210	

Effect of Test Temperature

Code No.	Heat Treat	Surf. Fin.	Freq.	Temp. °F	K <sup>c</sup>	Other	DISP.	Param.	1x10 <sup>3</sup>	1x10 <sup>4</sup>	5x10 <sup>4</sup>	1x10 <sup>5</sup>	5x10 <sup>5</sup>	1x10 <sup>6</sup>	5x10 <sup>6</sup>	1x10 <sup>7</sup>	1x10 <sup>8</sup>
547				1800	1.0		L.F.V.	M	.3606*	.4080	.4449	.4617	.5034	.5225	.5697	.5913	
							L.F.V.	M	55.99	49.48	45.38	43.72	40.10	38.64	35.44	34.14	
548				2000	1.0		Wetbull	q	1.840*	1.840	1.840	1.840	1.840	1.840	1.840	1.840*	
							Wetbull	q	47.65	36.83	30.77	28.48	23.78	22.01	18.39	17.01	
							Wetbull	q	36.29	28.06	23.44	21.63	18.12	16.77	14.00	12.96	

Composition: See Page 170  
 (\*) Extrapolated Values

T1 - 4 A1 - 3 Mo - 1 V

S<sub>y</sub> = 119-201 ksi  
 S<sub>u</sub> = 84-180 ksi

Code No.	TEST CONDITIONS			FATIGUE STRENGTH DISTRIBUTIONS AND THEIR PARAMETERS												
	Heat Treat	Surf. Fin.	Freq.	Temp °F	R <sub>r</sub>	Other	DIST.	LIFE IN CYCLES								
								1x10 <sup>3</sup>	1x10 <sup>4</sup>	5x10 <sup>4</sup>	1x10 <sup>5</sup>	5x10 <sup>5</sup>	1x10 <sup>6</sup>	5x10 <sup>6</sup>	1x10 <sup>7</sup>	1x10 <sup>8</sup>

PLATE BENDING (Completely Reversed)  
 Effect of Heat Treatment

549	HT-41			80	1.0			1.420*	1.751	1.483	1.420	1.546	1.590	1.525	1.590*	
								184.2	122.0	91.18	80.47	60.29	53.24	39.84	35.19	
								144.7	93.07	71.29	63.22	46.90	41.25	31.04	27.26	
550	HT-42			80	1.0			8.433	117.0	5.648	4.752	3.182*	2.677*			
										78.36	65.94	44.16	37.15			

962

AXIAL (Completely Reversed)  
 Effect of Sheet Thickness

551	HT-43			900	1.0	.125 in. Thick		5.083*	4.941	4.878	4.854	4.804	4.783	4.596	4.558*	
								86.87	67.85	57.09	53.00	44.60	41.40	34.83	32.34	
								40.65	32.56	27.71	25.82	21.92	20.42	17.72	16.55	
552	HT-43			900	1.0	.020 in. Thick		.0889*	.1299	.1693	.1898	.2474	.2773	.3615	.4051*	
								91.88	62.89	48.25	43.05	33.03	29.47	22.61	20.17	

HT-41: Sol. H.T. 1625°F, 15 min., W.Q., Tempered at 1050°F, 11 hrs., Heat Treat Medium: A-47 Glass  
 HT-42: Sol. H.T. at Mill. Tempered at 1050°F for 6 hrs.  
 HT-43: 1655°F, 15-30 min., 925°F, 12 hrs.

Composition: See Page 170  
 (\*) Extrapolated Values

Ti - 4 Al - 3 Mo - 1 V (Cont'd)

S<sub>y</sub> = 119-201 ksi  
 S<sub>u</sub> = 84-180 ksi

Code No.	TEST CONDITIONS				FATIGUE STRENGTH DISTRIBUTIONS AND THEIR PARAMETERS											
	Heat Treat	Surf. Fin.	Freq.	Temp °F	K <sub>t</sub>	Other	DIST.	Param.	LIFE IN CYCLES							
									1x10 <sup>3</sup>	1x10 <sup>4</sup>	5x10 <sup>4</sup>	1x10 <sup>5</sup>	5x10 <sup>5</sup>	1x10 <sup>6</sup>	5x10 <sup>6</sup>	1x10 <sup>7</sup>

AXIAL (Completely Reversed)  
 Effect of Sheet Thickness

Code No.	Heat Treat	Surf. Fin.	Freq.	Temp °F	K <sub>t</sub>	Other	DIST.	Param.	1x10 <sup>3</sup>	1x10 <sup>4</sup>	5x10 <sup>4</sup>	1x10 <sup>5</sup>	5x10 <sup>5</sup>	1x10 <sup>6</sup>	5x10 <sup>6</sup>	1x10 <sup>7</sup>	1x10 <sup>8</sup>
553	HT-43		30	80	2.8	.020 in. Thick	Wetbull	b <sub>0</sub>	1.323*	1.428	1.309	1.448	1.402	1.441	1.261	1.421*	
								θ	79.65	58.08	46.48	42.31	33.89	30.82	24.64	22.44	
								q	62.63	45.21	36.59	32.87	26.44	23.95	19.48	17.48	
554	HT-43		30	80	2.8	.063 in. Thick	Wetbull	b <sub>0</sub>	1.037*	1.082	.9512	.9856	1.048	1.070	1.111	1.126*	
								θ	83.68	64.22	53.20	49.14	40.86	37.73	31.37	28.97	
								q	64.00	48.88	41.02	37.77	31.21	28.76	23.79	21.93	
555	HT-43		30	80	2.8	.125 in. Thick	Normal	σ	7.307*	5.745	4.856	4.517	3.818	3.551	3.001	2.792*	
								τ	74.65	58.69	49.61	46.15	39.00	36.28	30.66	28.52	
556	HT-43		30	400	2.8	.020 in. Thick	L.F.V.	σ	.2166*	.2595	.2944	.3108	.3526	.3723	.4224	.4460	
								τ	58.46	48.80	43.01	40.74	35.91	34.01	29.97	28.39	
557	HT-43		30	400	2.8	.063 in. Thick	Wetbull	b <sub>0</sub>	1.930*	1.920	1.970	1.930	1.931	1.981	1.924	1.903*	
								θ	80.61	58.30	46.51	42.17	33.63	30.52	24.32	22.06	
								q	57.96	41.97	33.28	30.32	24.18	21.81	17.50	15.91	
558	HT-43		30	400	2.8	.125 in. Thick	Wetbull	b <sub>0</sub>	1.654*	1.564	1.602	1.616	1.640	1.641	1.573	1.531*	
								θ	72.09	55.96	46.92	43.49	36.46	33.80	28.31	26.23	
								q	52.01	40.82	34.07	31.52	26.35	24.42	20.63	19.21	

Milled and Ground Edges

Composition: See Page 170  
 (\*) Extrapolated Values

T1 - 4 Al - 3 Mo - 1 V (Cont'd)

S<sub>u</sub> = 119-201 ksi  
 S<sub>y</sub> = 84-180 ksi

Code No.	TEST CONDITIONS			FATIGUE STRENGTH DISTRIBUTIONS AND THEIR PARAMETERS													
	Heat Treat	Surt. Fin.	Freq.	Temp.	K <sub>t</sub>	Other	DIST.	Param.	LIFE IN CYCLES								
									1x10 <sup>3</sup>	1x10 <sup>4</sup>	5x10 <sup>4</sup>	1x10 <sup>5</sup>	5x10 <sup>5</sup>	1x10 <sup>6</sup>	5x10 <sup>6</sup>	1x10 <sup>7</sup>	1x10 <sup>8</sup>

AXIAL (Completely Reversed)  
 Effect of Sheet Thickness

Code No.	Heat Treat	Surt. Fin.	Freq.	Temp.	K <sub>t</sub>	Other	DIST.	Param.	1x10 <sup>3</sup>	1x10 <sup>4</sup>	5x10 <sup>4</sup>	1x10 <sup>5</sup>	5x10 <sup>5</sup>	1x10 <sup>6</sup>	5x10 <sup>6</sup>	1x10 <sup>7</sup>	1x10 <sup>8</sup>
559	HT-43		30	600	2.8	.020 in. Thick	Webull	σ <sub>q</sub>	.9897*	1.039	.9378	.9931	.6935	.7701	.8912	.9309*	
							Webull	σ <sub>q</sub>	62.30	49.99	42.74	40.03	34.08	31.93	27.43	25.69	
							Webull	σ <sub>q</sub>	54.65	43.69	37.62	35.11	30.42	28.40	24.22	22.62	
560	HT-43		30	500	2.8	.063 in. Thick	Webull	σ <sub>q</sub>	2.150*	2.078	2.150	2.150	2.049	2.151	2.138	2.034*	
							Webull	σ <sub>q</sub>	75.24	55.05	44.28	40.31	32.39	29.50	23.72	21.58	
							Webull	σ <sub>q</sub>	51.30	37.90	30.19	27.48	22.39	20.11	16.20	14.94	
561	HT-43		30	600	2.8	.125 in. Thick	Webull	σ <sub>q</sub>	3.549*	3.558	3.470	3.436	3.541	3.457	3.592	3.549*	
							Webull	σ <sub>q</sub>	74.75	56.41	46.33	42.56	34.96	32.12	26.38	24.24	
							Webull	σ <sub>q</sub>	47.60	35.95	29.83	27.52	22.33	20.71	16.74	15.46	
562	HT-43		30	800	2.8	.020 in. Thick	Normal	σ <sub>q</sub>	9.873*	7.742	6.532	6.071	5.123	4.761	4.017	3.734	
							Normal	σ <sub>q</sub>	62.68	49.15	41.47	38.54	32.52	30.23	25.50	23.70	
563	HT-43		30	800	2.8	.063 in. Thick	Webull	σ <sub>q</sub>	1.919*	1.956	1.839	1.837	1.892	1.862	1.932	1.909*	
							Webull	σ <sub>q</sub>	56.47	44.98	38.32	35.78	30.52	28.49	24.31	22.69	
							Webull	σ <sub>q</sub>	37.94	30.05	26.04	24.32	20.59	19.30	16.30	15.27	
564	HT-43		30	800	2.8	.125 in. Thick	L.E.V.	σ <sub>q</sub>	.1780*	.2342	.2837	.3081	.3732	.4053	.4910	.5333*	
							L.E.V.	σ <sub>q</sub>	52.99	40.28	33.25	30.62	25.28	23.27	19.21	17.69	

T1 - 4 Al - 3 Mo - 1 V (Cont'd)  
Composition: See Page 170  
(\* ) Extrapolated Values

S<sub>u</sub> = 119-201 ksi  
S<sub>y</sub> = 84-180 ksi

Code No.	TEST CONDITIONS				FATIGUE STRENGTH DISTRIBUTIONS AND THEIR PARAMETERS											
	Heat Treat	Surf. Fin.	Freq.	Temp.	K <sub>t</sub>	Other	DIST.	Param.	LIFE IN CYCLES							
									1x10 <sup>3</sup>	1x10 <sup>4</sup>	5x10 <sup>4</sup>	1x10 <sup>5</sup>	5x10 <sup>5</sup>	1x10 <sup>6</sup>	5x10 <sup>6</sup>	1x10 <sup>7</sup>

AXIAL (Completely Reversed)  
Effect of Sheet Thickness

Code No.	Heat Treat	Surf. Fin.	Freq.	Temp.	K <sub>t</sub>	Other	DIST.	Param.	LIFE IN CYCLES							
									1x10 <sup>3</sup>	1x10 <sup>4</sup>	5x10 <sup>4</sup>	1x10 <sup>5</sup>	5x10 <sup>5</sup>	1x10 <sup>6</sup>	5x10 <sup>6</sup>	1x10 <sup>7</sup>
565	HT-43		30	900	2.8	Thick	Webull	σ <sub>0</sub>	3.813*	3.728	3.682	3.665	3.630	3.618	3.592	3.563*
									59.93	44.91	36.70	33.65	27.50	25.21	20.61	18.89
566	HT-43		30	900	2.8	Thick	Normal	σ <sub>0</sub>	7.134*	4.784	3.619	3.209	2.427	2.152	1.627*	1.443*
									61.36	41.15	31.13	27.60	20.87	18.51	14.00	12.41
567	HT-43		30	900	2.8	Thick	Webull	σ <sub>0</sub>	1.690*	1.619	1.647	1.625	1.691	1.656	1.584*	1.717*
									54.89	41.53	34.19	31.44	25.89	23.81	19.58	18.03
568	HT-43		30	400	1.0	Thick	Webull	σ <sub>0</sub>	1.097*	1.222	1.097	1.097	1.150	1.111	1.036*	1.160*
									109.3	87.11	74.09	69.16	58.97	55.02	46.84	43.79
569	HT-43		30	400	1.0	Thick	Normal	σ <sub>0</sub>	89.03	70.20	60.34	56.32	47.82	44.75	38.30	35.48
									19.51*	13.49	10.42	9.328	7.207	6.449	4.982	4.458*
									129.7	89.67	69.28	61.99	47.90	33.11	29.63	



S<sub>y</sub> = 119-201 ksi  
 S<sub>u</sub> = 84-180 ksi

TI - 4 Al - 3 Mo - 1 V (Cont'd)

Composition: See Page 170  
 (\*) Extrapolated Values

Code No.	TEST CONDITIONS				FATIGUE STRENGTH DISTRIBUTIONS AND THEIR PARAMETERS													
	Heat Treat	Surt.	Fin.	Req.	Temp	R <sub>r</sub>	Other	DIST.	Param	LIFE IN CYCLES								
										1x10 <sup>3</sup>	1x10 <sup>4</sup>	5x10 <sup>4</sup>	1x10 <sup>5</sup>	5x10 <sup>5</sup>	1x10 <sup>6</sup>	5x10 <sup>6</sup>	1x10 <sup>7</sup>	1x10 <sup>8</sup>

AXIAL (Completely Reversed)  
 Effect of Sheet Thickness

570	HT-43			30	600	1.0	.020 in. Thick	Normal	r <sub>s</sub>	19.88*	15.46	12.97	12.02	10.08	9.353	7.845	7.273*	
571	HT-43			30	600	1.0	.063 in. Thick	Normal	r <sub>s</sub>	27.89*	18.65	14.08	12.48	9.425	8.350	6.305	5.586*	
572	HT-43			30	800	1.0	.020 in. Thick	Wetbulb	r <sub>s</sub> θ <sub>q</sub>	1.530*	1.450	1.582	1.597	1.556	1.520	1.443	1.590*	
573	HT-43			30	800	1.0	.063 in. Thick	Wetbulb	r <sub>s</sub> θ <sub>q</sub>	100.2	75.66	62.28	57.25	47.05	43.22	35.51	32.68	
										75.45	57.45	46.62	42.78	35.32	32.58	26.98	24.44	
										.7546*	.9953	.7156	.8323	.9262	.9562	1.011	1.030	
										88.94	65.12	50.94	46.48	37.21	33.79	26.98	24.48	
										72.39	51.10	41.63	37.45	29.54	26.69	21.11	19.08	

Composition: See Page 170  
 (\*) Extrapolated Values

TI - 4 Al - 3 Mo - 1 V (Cont'd)

S<sub>y</sub> = 119-201 ksi  
 S<sub>u</sub> = 84-180 ksi

Code	TEST CONDITIONS				FATIGUE STRENGTH DISTRIBUTIONS AND THEIR PARAMETERS											
	Heat Treat	Surf. Fin.	Req. Temp.	r	Other	Dist.	Param.	LIFE IN CYCLES								
								1x10 <sup>3</sup>	1x10 <sup>4</sup>	5x10 <sup>4</sup>	1x10 <sup>5</sup>	5x10 <sup>5</sup>	1x10 <sup>6</sup>	5x10 <sup>6</sup>	1x10 <sup>7</sup>	1x10 <sup>8</sup>

AXIAL (Completely Reversed)  
 Effect of Stress Concentration.

Code	Heat Treat	Surf. Fin.	Req. Temp.	r	Other	Dist.	Param.	1x10 <sup>3</sup>	1x10 <sup>4</sup>	5x10 <sup>4</sup>	1x10 <sup>5</sup>	5x10 <sup>5</sup>	1x10 <sup>6</sup>	5x10 <sup>6</sup>	1x10 <sup>7</sup>	1x10 <sup>8</sup>
574	HT-43		30	1.0		Normal	b	11.79*	9.065	7.540	6.965	5.793	5.351	4.451	4.111*	
								108.2	83.18	69.19	63.91	53.16	49.10	40.84	37.73	
575	HT-43		30	2.8		Webull	b	1.654*	1.564	1.602	1.616	1.640	1.641	1.573	1.531*	
								72.09	55.96	46.92	43.49	36.46	33.80	28.31	26.23	
								52.01	40.82	34.07	31.52	26.35	24.42	20.63	19.21	
576	HT-43		30	1.0		L.E.V.	B	.9152*	.1140	.1330	.1421	.1658	.1771	.2066	.2208	
								92.10	73.90	63.36	59.29	50.83	47.57	40.79	38.17	
577	HT-43		30	2.8		Webull	b	3.549*	3.558	3.470	3.436	3.541	3.457	3.592	3.549*	
								74.75	56.41	46.33	42.56	34.96	32.12	26.38	24.24	
								47.69	35.95	29.83	27.52	22.33	20.71	16.74	15.46	
578	HT-43		30	1.0		L.E.V.	B	.8963*	.1223	.1521	.1670	.2077	.2281	.2836	.3114*	
								90.94	66.61	53.58	48.78	39.24	35.73	28.74	26.17	
579	HT-43		30	2.8		L.E.V.	B	.1780*	.2342	.2837	.3081	.3732	.4053	.4910	.5333*	
								52.99	40.28	33.25	30.62	25.28	23.27	19.21	17.69	

Longitudinal Sheet = .125 in. Thick

Milled and Ground Edges

S<sub>u</sub> = 119-201 ksi  
 S<sub>y</sub> = 84-180 ksi

TI - 4 A1 - 3 Mo - 1 V (Cont'd)

Composition: See Page 170  
 (\*) Extrapolated Values

†Code No.	TEST CONDITIONS				Other	DISTR.	Param.	FATIGUE STRENGTH DISTRIBUTIONS AND THEIR PARAMETERS								
	Heat Treat	Surf. Fin.	Freq.	Temp °F				K <sub>t</sub>	LIFE IN CYCLES							
								1x10 <sup>3</sup>	1x10 <sup>4</sup>	5x10 <sup>4</sup>	1x10 <sup>5</sup>	5x10 <sup>5</sup>	1x10 <sup>6</sup>	5x10 <sup>6</sup>	1x10 <sup>7</sup>	1x10 <sup>8</sup>

AXIAL (Completely Reversed)  
 Effect of Stress Concentration

580	HT-43	Milled and Ground Edges	30	900	1.0	.125 in. Thick	Webull	X <sub>0</sub>	4.941	4.878	4.854	4.804	4.783	4.596	4.558*	
							Webull	q	5.083*	4.878	4.854	4.804	4.783	4.596	4.558*	
							Webull	q	86.87	57.09	53.00	44.60	41.40	34.83	32.34	
							Webull	q	40.65	27.71	25.82	21.92	20.42	17.72	16.55	
581	HT-43	Milled and Ground Edges	30	900	2.8	.125 in. Thick	Webull	b	1.690*	1.647	1.625	1.691	1.656	1.584*	1.717*	
							Webull	q	54.89	34.19	31.44	25.89	23.81	19.58	18.03	
							Webull	q	39.89	24.98	23.02	18.82	17.37	14.41	13.06	
582	HT-43	Milled and Ground Edges	30	900	1.0	.20 in. Thick	L.E.V.	M	.8896*	.1693	.1898	.2474	.2773	.3615	.4051*	
							L.E.V.	M	91.88	48.25	43.05	33.03	29.47	22.61	20.17	
583	HT-43	Milled and Ground Edges	30	900	2.8	.20 in. Thick	Webull	b	3.813*	3.682	3.665	3.630	3.618	3.592	3.563*	
							Webull	q	59.93	36.70	33.65	27.50	25.21	20.61	18.89	
							Webull	q	25.97	16.43	15.12	12.46	11.46	9.431	8.705	

Effect of Test Temperature

584	HT-43	Milled and Ground Edges	30	80	1.0	.125 in. Thick	Normal	n	15.69*	12.40	9.805	8.318	7.749	6.573	6.124*	
							Normal	n	122.6	96.93	76.60	64.98	60.54	51.36	47.84	
585	HT-43	Milled and Ground Edges	30	400	1.0	.125 in. Thick	Normal	n	11.79*	9.065	6.965	5.793	5.351	4.451	4.111*	
							Normal	n	108.2	83.18	63.91	53.16	49.10	40.84	37.73	

Composition: See Page 170  
 (\*) Extrapolated Values

T1 - 4 Al - 3 Mo - 1 V (Cont'd)

S<sub>u</sub> = 119-201 ksi  
 S<sub>y</sub> = 84-180 ksi

Code No.	TEST CONDITIONS				FATIGUE STRENGTH DISTRIBUTIONS AND THEIR PARAMETERS							
	Heat Treat	Surt. Fin.	Freq.	Temp	r	LIFE IN CYCLES						
	Other	DIST.	Param.	1x10 <sup>3</sup>	1x10 <sup>4</sup>	5x10 <sup>4</sup>	1x10 <sup>5</sup>	5x10 <sup>5</sup>	1x10 <sup>6</sup>	5x10 <sup>6</sup>	1x10 <sup>7</sup>	1x10 <sup>8</sup>

AXIAL (Completely Reversed)  
 Effect of Test Temperature

Code No.	Heat Treat	Surt. Fin.	Freq.	Temp	r	DIST.	Param.	1x10 <sup>3</sup>	1x10 <sup>4</sup>	5x10 <sup>4</sup>	1x10 <sup>5</sup>	5x10 <sup>5</sup>	1x10 <sup>6</sup>	5x10 <sup>6</sup>	1x10 <sup>7</sup>	1x10 <sup>8</sup>
586	HT-43	Milled and Ground Edges	30	600	1.0	Longitudinal Sheet .125 in. Thick	Wetbulb L.F.V.	8 M	.9152* 92.10	.1140 73.90	.1330 63.36	.1421 59.29	.1658 50.83	.1771 47.57	.2066 40.79	.2208 38.17
587	HT-43		30	800	1.0		Wetbulb L.F.V.	8 M	.8963* 90.94	.1223 66.61	.1521 53.58	.1670 48.78	.2077 39.24	.2281 35.73	.2836 28.74	.3114* 26.17
588	HT-43		30	900	1.0		Wetbulb L.F.V.	8 M	5.083* 86.87 40.65	4.941 67.85 32.56	4.878 57.09 27.71	4.854 53.00 25.82	4.804 44.60 21.92	4.783 41.40 20.42	4.596 34.83 17.72	4.558* 32.34 16.55
589	HT-43		30	80	2.8		Wetbulb L.F.V.	8 M	1.323* 79.65 62.63	1.428 58.08 45.21	1.309 46.48 36.59	1.448 42.31 32.87	1.402 33.89 26.44	1.441 30.82 23.95	1.261 24.64 19.48	1.421* 22.44 17.48
590	HT-43		30	400	2.8		Wetbulb L.F.V.	8 M	.2166* 58.46	.2595 48.80	.2944 43.01	.3108 40.74	.3526 35.91	.3723 34.01	.4224 29.97	.4460 28.39

Composition: See Page 170  
 (\*) Extrapolated Values

T1 - 4 A1 - 3 Mo - 1 V (Cont'd)

S<sub>y</sub> = 119-201 ksi  
 S<sub>u</sub> = 84-180 ksi

Code No.	TEST CONDITIONS				FATIGUE STRENGTH DISTRIBUTIONS AND THEIR PARAMETERS												
	Heat Treat	Surf. Fin.	Freq.	Temp.	K <sub>t</sub>	Other	DIST.	Param	LIFE IN CYCLES								
									1x10 <sup>3</sup>	1x10 <sup>4</sup>	5x10 <sup>4</sup>	1x10 <sup>5</sup>	5x10 <sup>5</sup>	1x10 <sup>6</sup>	5x10 <sup>6</sup>	1x10 <sup>7</sup>	1x10 <sup>8</sup>

AXIAL (Completely Reversed)  
 Effect of Test Temperature

Code No.	Heat Treat	Surf. Fin.	Freq.	Temp.	K <sub>t</sub>	Other	DIST.	Param	LIFE IN CYCLES								
									1x10 <sup>3</sup>	1x10 <sup>4</sup>	5x10 <sup>4</sup>	1x10 <sup>5</sup>	5x10 <sup>5</sup>	1x10 <sup>6</sup>	5x10 <sup>6</sup>	1x10 <sup>7</sup>	1x10 <sup>8</sup>
591	HT-43		30	600	2.8	Longitudinal Sheet .020 in. Thick	Wetball	b	.9897*	1.039	.9378	.9931	.6935	.7701	.8912	.9309*	
								θ	62.30	49.99	42.74	40.03	34.08	31.93	27.43	25.69	
								σ	54.65	43.69	37.62	35.11	30.42	28.40	24.22	22.62	
592	HT-43		30	800	2.8	Longitudinal Sheet .020 in. Thick	Normal	n	9.873*	7.742	6.532	6.071	5.123	4.761	4.017	3.734	
								σ	62.68	49.15	41.47	38.54	32.52	30.23	25.50	23.70	
593	HT-43		30	900	2.8	Longitudinal Sheet .020 in. Thick	Wetball	b	3.813*	3.728	3.682	3.665	3.630	3.618	3.592	3.563*	
								θ	59.93	44.91	36.70	33.65	27.50	25.21	20.61	18.89	
								σ	25.97	19.88	16.43	15.12	12.46	11.46	9.431	8.705	
594	HT-43		30	80	2.8	Longitudinal Sheet .063 in. Thick	Wetball	b	1.037*	1.082	.9512	.9856	1.048	1.070	1.111	1.126*	
								θ	83.68	64.22	53.20	49.14	40.86	37.73	31.37	28.97	
								σ	64.00	48.88	41.02	37.77	31.21	28.76	23.79	21.93	
595	HT-43		30	400	2.8	Longitudinal Sheet .063 in. Thick	Wetball	b	1.930*	1.920	1.970	1.930	1.931	1.981	1.924	1.903*	
								θ	80.61	58.30	46.51	42.17	33.63	30.52	24.32	22.06	
								σ	57.96	41.97	33.28	30.32	24.18	21.81	17.50	15.91	
596	HT-43		30	600	2.8	Longitudinal Sheet .063 in. Thick	Wetball	b	2.150*	2.078	2.150	2.150	2.049	2.151	2.138	2.034*	
								θ	75.24	55.05	44.28	40.31	32.39	29.50	23.72	21.58	
								σ	51.30	37.90	30.19	27.48	22.39	20.11	16.20	14.94	

Composition: See Page 170  
 (\*) Extrapolated Values

Ti - 4 Al - 3 Mo - 1 V (Cont'd)

S<sub>u</sub> = 119-201 ksi  
 S<sub>y</sub> = 84-180 ksi

+Code No.	TEST CONDITIONS				Other	DIST.	Param.	LIFE IN CYCLES							
	Heat Treat	Surt. Fin.	Freq.	Temp				K <sub>t</sub>	1x10 <sup>3</sup>	1x10 <sup>4</sup>	5x10 <sup>4</sup>	1x10 <sup>5</sup>	5x10 <sup>5</sup>	1x10 <sup>6</sup>	5x10 <sup>6</sup>

FATIGUE STRENGTH DISTRIBUTIONS AND THEIR PARAMETERS

AXIAL (Completely Reversed)  
 Effect of Test Temperature

+Code No.	Heat Treat	Surt. Fin.	Freq.	Temp	K <sub>t</sub>	Other	DIST.	Param.	1x10 <sup>3</sup>	1x10 <sup>4</sup>	5x10 <sup>4</sup>	1x10 <sup>5</sup>	5x10 <sup>5</sup>	1x10 <sup>6</sup>	5x10 <sup>6</sup>	1x10 <sup>7</sup>	1x10 <sup>8</sup>
597	HT-43	Milled and Ground Edges	30	800	2.8	.063 in. Thick	Normal Weibull	σ <sub>0</sub>	1.919*	1.956	1.839	1.837	1.892	1.862	1.932	1.909*	
								σ <sub>0</sub>	56.47	44.98	38.32	35.78	30.52	28.49	24.31	22.69	
								σ <sub>0</sub>	37.94	30.05	26.04	24.32	20.59	19.30	16.30	15.27	
598	HT-43		30	900	2.8		Normal Weibull	n <sub>0</sub>	7.134*	4.784	3.619	3.209	2.427	2.152	1.627*	1.443*	
								n <sub>0</sub>	61.36	41.15	31.13	27.60	20.87	18.51	14.00	12.41	
599	HT-43		30	80	2.8		Normal Weibull	n <sub>0</sub>	7.307*	5.745	4.856	4.517	3.818	3.551	3.001	2.792*	
								n <sub>0</sub>	74.65	58.69	49.61	46.15	39.00	36.28	30.66	28.52	
600	HT-43		30	400	2.8		Normal Weibull	b	1.654*	1.564	1.602	1.616	1.640	1.641	1.573	1.531*	
								b	72.09	55.96	46.92	43.49	36.46	33.80	28.31	26.23	
								b	52.01	40.82	34.07	31.52	26.35	24.42	20.63	19.21	
601	HT-43		30	600	2.8		Normal Weibull	b	3.549*	3.558	3.470	3.436	3.541	3.457	3.592	3.549*	
								b	74.75	56.41	46.33	42.56	34.96	32.12	26.38	24.24	
								b	47.69	35.95	29.83	27.52	22.33	20.71	16.74	15.46	

Composition: See Page 170  
 (\*) Extrapolated Values

T1 - 4 Al - 3 Mg - 1 V (Cont'd)

S = 119-201 ksi  
 S<sub>u</sub> = 84-180 ksi

Code No.	TEST CONDITIONS				FATIGUE STRENGTH DISTRIBUTIONS AND THEIR PARAMETERS											
	Heat Treat	Surf. Fin.	Temp. °F	R <sub>r</sub>	Other	DIST.	Form	LIFE IN CYCLES								
								1x10 <sup>3</sup>	1x10 <sup>4</sup>	5x10 <sup>4</sup>	1x10 <sup>5</sup>	5x10 <sup>5</sup>	1x10 <sup>6</sup>	5x10 <sup>6</sup>	1x10 <sup>7</sup>	1x10 <sup>8</sup>

AXIAL (Completely Reversed)  
 Effect of Test Temperature

Code No.	Heat Treat	Surf. Fin.	Temp. °F	R <sub>r</sub>	Other	DIST.	Form	1x10 <sup>3</sup>	1x10 <sup>4</sup>	5x10 <sup>4</sup>	1x10 <sup>5</sup>	5x10 <sup>5</sup>	1x10 <sup>6</sup>	5x10 <sup>6</sup>	1x10 <sup>7</sup>	1x10 <sup>8</sup>
602	HT-43	Milled and Ground Edges	800	2.8	.125 in. Thick	L.E.V.	β	.1780*	.2342	.2837	.3081	.3732	.4053	.4910	.5333*	
					Longitudinal Sheet	Normal Weibull	σ	52.99	40.28	33.25	30.62	25.28	23.27	19.21	17.69	
603	HT-43	Milled and Ground Edges	900	2.8	.125 in. Thick	L.E.V.	β	1.690*	1.619	1.647	1.625	1.691	1.656	1.584*	1.717*	
					Longitudinal Sheet	Normal Weibull	σ	54.89	41.53	34.19	31.44	25.89	23.81	19.58	18.03	
						Normal Weibull	σ	39.89	30.44	24.98	23.02	18.82	17.37	14.41	13.06	
604	HT-43	Milled and Ground Edges	400	1.0	.125 in. Thick	L.E.V.	β	1.097*	1.222	1.097	1.097	1.150	1.111	1.036*	1.160*	
					Longitudinal Sheet	Normal Weibull	σ	109.3	87.11	74.09	69.16	58.97	55.02	46.84	43.79	
						Normal Weibull	σ	89.03	70.20	60.34	56.32	47.82	44.75	38.30	35.48	
605	HT-43	Milled and Ground Edges	600	1.0	.125 in. Thick	L.E.V.	β	19.88*	15.46	12.97	12.02	10.08	9.353	7.845	7.273*	
					Longitudinal Sheet	Normal Weibull	σ	102.5	79.74	66.88	62.01	52.01	48.22	40.45	37.50	
						Normal Weibull	σ									
606	HT-43	Milled and Ground Edges	800	1.0	.125 in. Thick	L.E.V.	β	1.530*	1.450	1.582	1.597	1.556	1.520	1.443	1.590*	
					Longitudinal Sheet	Normal Weibull	σ	100.2	75.66	62.28	57.25	47.05	43.22	35.51	32.68	
						Normal Weibull	σ	75.45	57.45	46.62	42.78	35.32	32.58	26.98	24.44	
607	HT-43	Milled and Ground Edges	900	1.0	.125 in. Thick	L.E.V.	β	.165E*	.2132	.2542	.2742	.3269	.3526	.4203*	.4534*	
					Longitudinal Sheet	Normal Weibull	σ	86.57	67.32	56.46	52.35	43.91	40.70	34.14	31.65	
						Normal Weibull	σ									

Composition: See Page 170  
 (\*) Extrapolated Values

T1 - 4 Al - 3 Mo - 1 V (Cont'd)

S<sub>u</sub> = 119-201 ksi  
 S<sub>y</sub> = 84-180 ksi

Code No.	TEST CONDITIONS				FATIGUE STRENGTH DISTRIBUTIONS AND THEIR PARAMETERS												
	Heat Treat	Surf. Fin.	Freq.	Temp.	R <sub>r</sub>	Other	DIST.	Param.	LIFE IN CYCLES								
									1x10 <sup>3</sup>	1x10 <sup>4</sup>	5x10 <sup>4</sup>	1x10 <sup>5</sup>	5x10 <sup>5</sup>	1x10 <sup>6</sup>	5x10 <sup>6</sup>	1x10 <sup>7</sup>	1x10 <sup>8</sup>

AXIAL (Completely Reversed)  
 Effect of Test Temperature

608	HT-43	Ground Edges	30	80	1.0		Webull	σ <sub>0</sub>	2.642*	2.642	2.642	2.642	2.614	2.535	2.597*	2.540*	
								σ <sub>0</sub>	145.5	104.9	83.56	75.74	60.28	54.63	43.49	39.41	
								σ <sub>0</sub>	108.3	78.16	62.21	56.39	44.99	41.05	32.50	29.60	
609	HT-43		30	400	1.0		Normal	σ <sub>0</sub>	19.51*	13.49	10.42	9.328	7.207	6.449	4.982	4.458*	
								σ <sub>0</sub>	129.7	89.67	69.28	61.99	47.90	42.86	33.11	29.63	
610	HT-43		30	600	1.0		Normal	σ <sub>0</sub>	27.89*	18.65	14.08	12.48	9.425	8.350	6.305	5.586*	
								σ <sub>0</sub>	123.7	82.75	62.48	55.36	41.80	37.03	27.96	24.77	

S<sub>u</sub> = 152 ksi  
 S<sub>y</sub> = 139 ksi

Composition: See Page 170  
 (\*) Extrapolated Values

T1 - 4 Al - 4 Mn

ROTARY BEAM BENDING  
 Effect of Test Temperature

611	16 hrs. at 1300°F, P.C.	Mechanical Polish		80	1.0		Webull	σ <sub>0</sub>		2.116	2.116	2.610*	2.104*	2.498*			
								σ <sub>0</sub>	126.8	97.81	87.52	67.48	60.37	60.37			
								σ <sub>0</sub>	116.1	89.63	78.95	61.85	54.66	54.66			
612				600	1.0		S.E.V. Webull	σ <sub>0</sub>	.2458*	.4190	.4606	.5736*	.6304*				
								σ <sub>0</sub>	123.5	90.24	72.46	52.94	48.17				



Composition: See Page 170  
 (\*) Extrapolated Values

T1 - 5 Al - 2.5 Sn

Code No.	TEST CONDITIONS				FATIGUE STRENGTH DISTRIBUTIONS AND THEIR PARAMETERS											
	Heat Treat	Surf. Fin.	Freg.	Temp °F	K <sub>t</sub>	Other	DIST.	PARAM.	LIFE IN CYCLES							
									1x10 <sup>3</sup>	1x10 <sup>4</sup>	5x10 <sup>4</sup>	1x10 <sup>5</sup>	5x10 <sup>5</sup>	1x10 <sup>6</sup>	5x10 <sup>6</sup>	1x10 <sup>7</sup>

AXIAL (Completely Reversed)  
 Miscellaneous

Code No.	S <sub>u</sub> ksi	S <sub>y</sub> ksi	Temp °F	K <sub>t</sub>	Other	DIST.	PARAM.	LIFE IN CYCLES							
								1x10 <sup>3</sup>	1x10 <sup>4</sup>	5x10 <sup>4</sup>	1x10 <sup>5</sup>	5x10 <sup>5</sup>	1x10 <sup>6</sup>	5x10 <sup>6</sup>	1x10 <sup>7</sup>
613	134	126	80	1.0		S.E.V.	β	.2013	.2324	.2569	.2683	.2966	.3097	.3425	.3576*
								107.6	93.23	84.32	80.76	73.04	69.95	63.27	60.59

S<sub>u</sub> = 134 ksi  
 S<sub>y</sub> = 126 ksi

T1 - 5 Al - 2.5 Sn - 0.07 N<sub>2</sub>

Composition: See Page 170  
 (\*) Extrapolated Values

ROTARY BEAM BENDING  
 Effect of Stress Concentration

Code No.	Material & Electropolish	Temp °F	K <sub>t</sub>	Other	Normal	r <sub>d</sub>	LIFE IN CYCLES							
							7.116*	6.479*	6.068	5.898	5.524	5.370	5.029	4.889
614	HT-44	80	1.0		Normal	r <sub>d</sub>	102.1	92.97	87.07	84.65	79.27	77.07	72.17	70.16
							7.116*	6.479*	6.068	5.898	5.524	5.370	5.029	4.889
615	HT-44	80	3.0		Normal	r <sub>d</sub>	4.204*	3.332*	2.832	2.641	2.245	2.093	1.779	1.659
							72.34	57.34	48.74	45.45	38.64	36.03	30.62	28.56

HT-44: 1550°F. 2 hrs.. F.C. to 1100°F. A.C.

T1 - 5 Al - 2.5 Sn - 0.2 O2  
Composition: See Page 170  
(\* Extrapolated Values)

S<sub>u</sub> = 132 ksi  
S<sub>y</sub> = 122 ksi

Code No.	TEST CONDITIONS				FATIGUE STRENGTH DISTRIBUTIONS AND THEIR PARAMETERS												
	Heat Treat	Surf. Fin.	Freq.	Temp °F	K <sub>t</sub>	Other	DIST.	Param.	LIFE IN CYCLES								
									1x10 <sup>3</sup>	1x10 <sup>4</sup>	5x10 <sup>4</sup>	1x10 <sup>5</sup>	5x10 <sup>5</sup>	1x10 <sup>6</sup>	5x10 <sup>6</sup>	1x10 <sup>7</sup>	1x10 <sup>8</sup>

ROTARY BEAM BENDING  
Effect of Stress Concentration

616	HT-45	Mechanical & Electropolish		80	1.0		S.E.V.	β M	.0933* 124.7	.1065* 109.2	.1169 99.51	.1217 95.60	.1336 87.12	.1390 83.70	.1526 76.26	.1588 73.27	
617	HT-45	Mechanical & Electropolish		80	3.0		Webull	β φ X <sub>o</sub>	2.225* 61.38 50.39	2.392* 53.70 43.60	2.322 48.88 39.88	2.294 46.94 38.37	2.231 42.73 35.07	2.206 41.04 33.74	2.431 37.39 30.28	2.410 35.91 29.12	

S<sub>u</sub> = 144 ksi  
S<sub>y</sub> = 137 ksi

T1 - 5 Al - 2.5 Sn - .2 C  
Composition: See Page 170  
(\* Extrapolated Values)

ROTARY BEAM BENDING  
Effect of Stress Concentration

618	HT-44	Mechanical & Electropolish		80	1.0		S.E.V.	β M	.1078* 123.7	.1280* 104.2	.1443* 92.48	.1520* 87.83	.1713 77.90	.1804 73.98	.2034 65.62	.2142 62.32	
619	HT-44	Mechanical & Electropolish		80	3.0		L.F.V.	β M	.3471* 75.86	.4398* 59.88	.5188 50.76	.5571 47.27	.6573 40.07	.7058 37.31	.8327 31.63	.8941 29.45	

HT-45: 1600°F, 2 hrs. F.C. to 1100°F, A.C.

$S_u = 160 \text{ ksi}$   
 $S_y = 153 \text{ ksi}$   
 $T1 - 5 \text{ Al} - 2.5 \text{ Sn} - 0.07 \text{ Ni} - .2(\text{O}_2) - .2 \text{ C}$   
 Composition: See Page 170  
 (\*) Extrapolated Values

Code No.	TEST CONDITIONS				FATIGUE STRENGTH DISTRIBUTIONS AND THEIR PARAMETERS												
	Heat Treat	Surf. Fin.	Freq.	Temp.	$K_t$	Other	DIST.	PARAM.	LIFE IN CYCLES								
									$1 \times 10^3$	$1 \times 10^4$	$5 \times 10^4$	$1 \times 10^5$	$5 \times 10^5$	$1 \times 10^6$	$5 \times 10^6$	$1 \times 10^7$	$1 \times 10^8$

ROTARY BEAM BENDING  
 Effect of Stress Concentration

Code No.	Heat Treat	Surf. Fin.	Freq.	Temp.	$K_t$	Other	DIST.	PARAM.	$1 \times 10^3$	$1 \times 10^4$	$5 \times 10^4$	$1 \times 10^5$	$5 \times 10^5$	$1 \times 10^6$	$5 \times 10^6$	$1 \times 10^7$	$1 \times 10^8$
620	HT-45	Mechanical & Electropolish	80	80	1.0		S.E.V. Weibull	b	1.838*	1.742*	1.838	1.838	1.661	1.721	1.838	1.827	
									120.8	106.6	97.91	94.22	86.32	83.17	76.28	73.47	
621	HT-45	Mechanical & Electropolish	80	80	3.0		S.E.V. Weibull	M	104.3	92.60	84.48	81.38	75.25	72.28	65.88	63.49	
									.1455*	.1760*	.2010	.2128	.2431	.2574	.2939	.3113	
									69.03	57.09	49.99	47.21	41.34	39.04	34.18	32.28	

S<sub>u</sub> = 132 ksi

T1 - 6 Al

Composition: See Page 170  
 (\*) Extrapolated Values

TEST CONDITIONS		FATIGUE STRENGTH DISTRIBUTIONS AND THEIR PARAMETERS										
Heat Treat	Surt. Fin.	Temp. °F	K <sub>t</sub>	Other	DIST.	Param.	LIFE IN CYCLES					1x10 <sup>8</sup>
							1x10 <sup>3</sup>	1x10 <sup>4</sup>	5x10 <sup>4</sup>	1x10 <sup>5</sup>	5x10 <sup>5</sup>	

ROTARY BEAM BENDING  
 Effect of Shot Peening

Code No.	Heat Treat	Surt. Fin.	Temp. °F	K <sub>t</sub>	Other	DIST.	Param.	1x10 <sup>3</sup>	1x10 <sup>4</sup>	5x10 <sup>4</sup>	1x10 <sup>5</sup>	5x10 <sup>5</sup>	1x10 <sup>6</sup>	5x10 <sup>6</sup>	1x10 <sup>7</sup>	1x10 <sup>8</sup>
622	Annealed	Hand Finish #120 Grit	80	1.0	No	Peened	Webull	3.194*	3.532*	3.194	3.532	3.194	3.194*	2.852*	3.532*	
								122.8	106.4	96.21	92.17	83.33	79.80	72.13	69.13	
								99.51	84.58	77.94	73.26	67.50	64.64	59.54	54.95	
623			80	1.0	Shot	Peened	Webull	4.362*	4.362*	4.362	4.362	4.362	4.362	4.146	3.928*	
								131.7	114.7	104.1	99.85	90.63	86.92	78.89	75.65	
								106.6	92.88	84.31	80.86	73.39	70.39	64.49	62.43	

Effect of Stress Concentration

Code No.	Heat Treat	Surt. Fin.	Temp. °F	K <sub>t</sub>	Other	DIST.	Param.	1x10 <sup>3</sup>	1x10 <sup>4</sup>	5x10 <sup>4</sup>	1x10 <sup>5</sup>	5x10 <sup>5</sup>	1x10 <sup>6</sup>	5x10 <sup>6</sup>	1x10 <sup>7</sup>	1x10 <sup>8</sup>
624	Annealed	Ground	80	1.0	V	Notch	S.E.V.	β	.1489*	.1645*	.1764*	.1818	.1949	.2008	.2153	.2218
M								110.9	100.3	93.63	90.87	84.75	82.25	76.72	74.45	
β								7.294*	7.546*	8.123	7.742	6.894	6.634	6.293*	6.226*	
β								70.92	49.25	38.17	34.20	26.50	23.74	18.40	16.48	
625	Annealed	Ground	80	3.0	V	Notch	S.E.V.	β	47.74	32.66	24.43	22.41	18.25	16.60	13.11	11.79
M								4.394*	4.768*	4.394	4.394	4.418	4.460	4.601*	4.395*	
β								90.54	69.07	57.14	52.67	43.59	40.17	33.25	30.64	
β								70.89	53.03	44.74	41.24	34.08	31.35	25.75	23.99	
626	Annealed	Lache Turned and Bored	80	2.5	Square	Notch	S.E.V.	β	4.394*	4.768*	4.394	4.394	4.418	4.460	4.601*	4.395*
M								90.54	69.07	57.14	52.67	43.59	40.17	33.25	30.64	
β								70.89	53.03	44.74	41.24	34.08	31.35	25.75	23.99	
β								1.781*	1.397*	1.453	1.822	1.449	1.502	1.515*	1.467*	
627	Annealed	Lache Turned and Bored	80	3.0	V	Notch	S.E.V.	β	83.47	64.01	53.31	49.41	41.01	37.91	31.56	29.16
M								71.10	55.89	46.40	41.96	35.70	32.89	27.36	25.35	
β								1.781*	1.397*	1.453	1.822	1.449	1.502	1.515*	1.467*	
β								83.47	64.01	53.31	49.41	41.01	37.91	31.56	29.16	

S<sub>u</sub> = 132 ksi

T1 - 6 Al (Cont'd)

Composition: See Page 170.  
(\* Extrapolated Values)

+Code No.	TEST CONDITIONS				FATIGUE STRENGTH DISTRIBUTIONS AND THEIR PARAMETERS												
	Heat Treat	Surf. Fin.	Freq.	Temp	K <sub>t</sub>	Other	DIST.	Param.	LIFE IN CYCLES								
									1x10 <sup>3</sup>	1x10 <sup>4</sup>	5x10 <sup>4</sup>	1x10 <sup>5</sup>	5x10 <sup>5</sup>	1x10 <sup>6</sup>	5x10 <sup>6</sup>	1x10 <sup>7</sup>	1x10 <sup>8</sup>

ROTARY BEAM BENDING  
Effect of Surface Finish

Code No.	Heat Treat	Surf. Fin.	Freq.	Temp	K <sub>t</sub>	Other	DIST.	Param.	LIFE IN CYCLES									
									1x10 <sup>3</sup>	1x10 <sup>4</sup>	5x10 <sup>4</sup>	1x10 <sup>5</sup>	5x10 <sup>5</sup>	1x10 <sup>6</sup>	5x10 <sup>6</sup>	1x10 <sup>7</sup>	1x10 <sup>8</sup>	
628	Hand	Ground Finish	80	80	1.0		Weibull	S.E.V. Weibull	3.194*	3.532*	106.4	3.194	3.532	3.194	3.194	3.194*	2.852*	3.532*
									122.8	92.17	96.21	83.33	79.80	72.13	69.13	72.13	69.13	
									99.51	73.26	77.94	67.50	64.64	59.54	54.95	59.54	54.95	
629	Ground	Ground	80	80	1.0		Weibull	S.E.V. Weibull	.1489*	.1818	.1764*	.1949	.1818	.1949	.2008	.2153	.2218	
									110.9	90.87	93.63	84.75	82.25	76.72	74.45	76.72	74.45	
630	17B	17B	80	80	3.0		Weibull	Weibull	1.781*	1.822	1.453	1.449	1.822	1.449	1.502	1.515*	1.467*	
									83.47	49.41	53.31	41.01	37.91	31.56	29.16	31.56	29.16	
									71.10	41.96	46.40	35.70	32.89	27.36	25.35	27.36	25.35	
631	Ground	Ground	80	80	3.0	V-Notch	Weibull	Weibull	1.294*	7.742	8.123	6.894	7.742	6.894	6.634	6.293*	6.226*	
									73.92	34.20	38.17	26.50	23.74	18.40	16.48	18.40	16.48	
									47.74	22.41	24.43	18.25	16.60	13.11	11.79	13.11	11.79	

Composition: See Page 170  
 (\*) Extrapolated Values

TI - 6 Al - 4 V

S<sub>u</sub> = 152-170 ksi  
 S<sub>y</sub> = 128-160 ksi

Code No.	TEST CONDITIONS				FATIGUE STRENGTH DISTRIBUTIONS AND THEIR PARAMETERS												
	Heat Treat	Surf. Fin.	Freq.	Temp. °F	K <sub>t</sub>	Other	DIST.	Fatigue	LIFE IN CYCLES								
									1x10 <sup>3</sup>	1x10 <sup>4</sup>	5x10 <sup>4</sup>	1x10 <sup>5</sup>	5x10 <sup>5</sup>	1x10 <sup>6</sup>	5x10 <sup>6</sup>	1x10 <sup>7</sup>	1x10 <sup>8</sup>

NOTARY BEAM BENDING

Effect of Heat Treatment

Code No.	Heat Treat	Surf. Fin.	Freq.	Temp. °F	K <sub>t</sub>	Other	DIST.	Fatigue	1x10 <sup>3</sup>	1x10 <sup>4</sup>	5x10 <sup>4</sup>	1x10 <sup>5</sup>	5x10 <sup>5</sup>	1x10 <sup>6</sup>	5x10 <sup>6</sup>	1x10 <sup>7</sup>	1x10 <sup>8</sup>
632	HT-46	Mechanical and Hand Polish 500-600 Grit	134	80	3.0		S.F.V.	σ <sub>8</sub>	2.733* 73.69	.3432* 57.40	.4086 48.20	.4405 44.71	.5245 37.55	.5655 34.83	.6733 29.25	.7259 27.13	
633	HT-47	Mechanical and Hand Polish 500-600 Grit	134	80	3.0		Webull	σ <sub>9</sub>	3.811* 73.30	3.764 60.46	3.744 52.84	3.596 49.86	3.746 43.59	3.606 41.13	3.831 35.96	3.728 33.93	
634	HT-48	Mechanical and Hand Polish 500-600 Grit	134	80	3.0		Webull	σ <sub>9</sub>	1.861* 76.58	1.660* 63.06	1.541 55.06	1.570 51.96	1.489 45.37	1.456 42.80	1.408 37.39	1.408 35.27	

Effect of Stress Concentration

Code No.	Heat Treat	Surf. Fin.	Freq.	Temp. °F	K <sub>t</sub>	Other	DIST.	Fatigue	1x10 <sup>3</sup>	1x10 <sup>4</sup>	5x10 <sup>4</sup>	1x10 <sup>5</sup>	5x10 <sup>5</sup>	1x10 <sup>6</sup>	5x10 <sup>6</sup>	1x10 <sup>7</sup>	1x10 <sup>8</sup>
635	HT-46	M.P. and Hand Polish	134	80	1.0		Normal	σ <sub>10</sub>	5.989* 107.5	5.754 103.3	5.594 100.4	5.527 99.25	5.374 96.50	5.310 95.35	5.163 92.71	5.101 91.59	
636	HT-46	M.P. and Hand Polish	134	80	3.0		S.F.V.	σ <sub>8</sub>	.2673* 73.68	.3432* 57.40	.4086 48.20	.4405 44.71	.5245 37.55	.5655 34.83	.6733 29.25	.7259 27.13	

HT-46: Duplex Annealed

HT-47: Triplex Annealed

HT-48: Beta Quenched, 1800°F, 1 hr., W.C.

Composition: See Page 170  
 (\*) Extrapolated Values

T1 - 6 Al - 4 V (Cont'd)

S<sub>u</sub> = 132-170 ksi  
 S<sub>y</sub> = 128-160 ksi

Code No.	TEST CONDITIONS				FATIGUE STRENGTH DISTRIBUTIONS AND THEIR PARAMETERS												
	Heat Treat	Surt. Fin.	Freq.	Temp	K <sub>t</sub>	Other	DIST.	Param	LIFE IN CYCLES								
									1x10 <sup>3</sup>	1x10 <sup>4</sup>	5x10 <sup>4</sup>	1x10 <sup>5</sup>	5x10 <sup>5</sup>	1x10 <sup>6</sup>	5x10 <sup>6</sup>	1x10 <sup>7</sup>	1x10 <sup>8</sup>

AXIAL (Completely Reversed)  
 Effect of Stress Concentration

637	Annealed	Milled Edges	134	800	1.0		Webull	b θ X <sup>o</sup> q	2.658* 50.07 30.39	2.656 43.74 26.56	2.644 42.70 25.98	2.617 40.39 24.68	2.606 39.43 24.14	2.582 37.30 22.92	2.571 36.41 22.41		
638			134	800	3.0		Webull	b θ X <sup>o</sup> q	1.346* 38.34 29.20	1.384 32.23 24.45	1.398 31.25 23.67	1.429 29.10 21.97	1.441 28.22 21.28	1.272 26.23 20.09	1.287* 25.44 19.46		

413

Effect of Test Temperature

639	Annealed	Milled Edges	134	80	1.0		Normal	r θ	7.503* 69.39	6.448 59.63	6.277 58.05	5.898 54.54	5.742 53.10	5.395 49.89	5.252* 48.57		
640			134	800	1.0		Webull	b θ X <sup>o</sup> q	2.658* 50.07 30.39	2.656 43.74 26.56	2.644 42.70 25.98	2.617 40.39 24.68	2.606 39.43 24.14	2.582 37.30 22.92	2.571 36.41 22.41		
641			134	1000	1.0		S.F.V.	β M	.4885* 39.42	.5151 37.38	.5200 37.03	.5315 36.23	.5366 35.89	.5484 35.11	.5536* 34.78		

Ti - 6 Al - 4 V (Cont'd)  
Composition: See Page 170  
(\* Extrapolated Values)

Ti - 6 Al - 4 V (Cont'd)

S<sub>u</sub> = 132-170 ksi  
S<sub>y</sub> = 128-160 ksi

Code No.	TEST CONDITIONS			FATIGUE STRENGTH DISTRIBUTIONS AND THEIR PARAMETERS													
	Heat Treat	Surf. Fin.	Freq.	Temp °K	K <sub>t</sub>	Other	DIST.	Param.	LIFE IN CYCLES								
									1x10 <sup>3</sup>	1x10 <sup>4</sup>	5x10 <sup>4</sup>	1x10 <sup>5</sup>	5x10 <sup>5</sup>	1x10 <sup>6</sup>	5x10 <sup>6</sup>	1x10 <sup>7</sup>	1x10 <sup>8</sup>

AXIAL (Completely Reversed)  
Effect of Test Temperature

Code No.	Heat Treat	Surf. Fin.	Freq.	Temp °K	K <sub>t</sub>	Other	DIST.	Param.	LIFE IN CYCLES								
									1x10 <sup>3</sup>	1x10 <sup>4</sup>	5x10 <sup>4</sup>	1x10 <sup>5</sup>	5x10 <sup>5</sup>	1x10 <sup>6</sup>	5x10 <sup>6</sup>	1x10 <sup>7</sup>	1x10 <sup>8</sup>
642	Annealed	Milled Edges	134	600	3.0		Webull	q	2.498*	2.482*	2.470	2.465	2.459	2.459	2.459	2.459*	2.459*
							Webull	q	41.99	38.90	36.87	36.03	34.16	33.38	31.64	30.92	
							Webull	q	30.64	28.43	26.97	26.37	25.01	24.44	23.17	22.65	
643	Annealed	Milled Edges	134	800	3.0		Webull	q	1.346*	1.296	1.384	1.398	1.429	1.441	1.272	1.287*	
							Webull	q	38.34	34.60	32.23	31.25	29.10	28.22	26.23	25.44	
							Webull	q	29.20	26.46	24.45	23.67	21.97	21.28	20.09	19.46	

S<sub>u</sub> = 162 ksi  
S<sub>y</sub> = 150 ksi  
Composition: See Page 170  
(\* Extrapolated Values)

Ti - 6 Al - 4 V - 0.07 Ni

ROTARY BEAM BENDING  
Effect of Stress Concentration

Code No.	Heat Treat	Surf. Fin.	Freq.	Temp °K	K <sub>t</sub>	Other	DIST.	Param.	LIFE IN CYCLES								
									1x10 <sup>3</sup>	1x10 <sup>4</sup>	5x10 <sup>4</sup>	1x10 <sup>5</sup>	5x10 <sup>5</sup>	1x10 <sup>6</sup>	5x10 <sup>6</sup>	1x10 <sup>7</sup>	1x10 <sup>8</sup>
644	HT-44	Mechanical & Electropolish		80	1.0		L.E.V.	β	.2198*	.2540*	.2809*	.2934*	.3246	.3390	.3750	.3916	
							L.E.V.	β	138.2	119.6	108.1	103.5	93.65	89.67	81.06	77.62	
645	HT-44	Mechanical & Electropolish		80	3.0		Webull	q	1.616*	1.616*	1.616	1.616	1.616	1.616	1.616	1.616	
							Webull	q	74.97	58.55	49.26	45.73	38.48	35.72	30.05	27.90	
							Webull	q	65.39	51.07	42.97	39.89	33.56	31.15	26.21	24.33	

HT-44: 1550°F, 2 hrs., F.C. to 1100°F, A.C.



S<sub>u</sub> = 161 ksi  
S<sub>y</sub> = 152 ksi

T1 - 6 Al - 4 V - 0.2 O2

Composition: See Page 171  
(\* Extrapolated Values)

Code No.	TEST CONDITIONS				FATIGUE STRENGTH DISTRIBUTIONS AND THEIR PARAMETERS											
	Heat Treat	Surf. Fin.	Freq.	Temp °F	K <sub>t</sub>	Other	DIST.	Param.	LIFE IN CYCLES							
									1x10 <sup>3</sup>	1x10 <sup>4</sup>	5x10 <sup>4</sup>	1x10 <sup>5</sup>	5x10 <sup>5</sup>	1x10 <sup>6</sup>	5x10 <sup>6</sup>	1x10 <sup>7</sup>

ROTARY BEAM BENDING

Effect of Stress Concentration

646	HT-45	Mechanical & Electropolish		80	1.0		L.F.V.	β M	.1375* 108.6	.1480* 100.9	.1558* 95.94	.1593 93.84	.1677 89.15	.1714 87.20	.1805 82.84	.1845 81.03	
647	HT-45	Mechanical & Electropolish		80	3.0		Wetbull	ρ q	3.357* 65.48 33.34	3.328* 56.52 28.97	3.309 50.99 26.25	3.302 48.78 25.15	3.286 44.02 22.77	3.280 42.11 21.82	3.266 37.99 19.74	3.261 36.35 18.91	

S<sub>u</sub> = 166 ksi  
S<sub>y</sub> = 159 ksi

T1 - 6 Al - 4 V - .2C

Composition: See Page 171  
(\* Extrapolated Values)

ROTARY BEAM BENDING

Effect of Stress Concentration

648	HT-44	Mechanical & Electropolish		80	1.0		L.F.V.	β M	.2010* 111.7	.2165* 103.7	.2281* 98.43	.2333* 96.25	.2458 91.36	.2513 89.33	.2648 84.79	.2708 82.91	
649	HT-44	Mechanical & Electropolish		80	3.0		Wetbull	ρ q	2.157* 61.90 45.67	2.157* 52.96 39.08	2.157 47.49 35.05	2.157 45.32 33.44	2.157 40.64 29.99	2.157 38.78 28.61	2.157 34.77 25.66	2.157 33.18 24.48	

HT-45: 1600°F, 2 hrs., F.C. to 1100°F, A.C.

Composition: See Page 171  
 (\*) Extrapolated Values

T1 - 6 Al - 4 V - 0.07 N2 - 0.2 O2 - 0.2 C

S<sub>u</sub> = 172 ksi  
 S<sub>y</sub> = 160 ksi

+Code No.	TEST CONDITIONS			FATIGUE STRENGTH DISTRIBUTIONS AND THEIR PARAMETERS													
	Heat Treat	Surf. Fin.	Freq.	Temp °F	K <sub>t</sub>	Other	DIST.	Param.	LIFE IN CYCLES								
									1x10 <sup>3</sup>	1x10 <sup>4</sup>	5x10 <sup>4</sup>	1x10 <sup>5</sup>	5x10 <sup>5</sup>	1x10 <sup>6</sup>	5x10 <sup>6</sup>	1x10 <sup>7</sup>	1x10 <sup>8</sup>

ROTARY BEAM BENDING  
 Effect of Stress Concentration

650	HT-49	Mechanical & Electropolish		80	1.0		L.E.V.	β M	.0906*	.1029*	.1125*	.1170*	.1279	.1329	.1453	.1510	
									137.2	120.8	110.4	106.3	97.23	93.57	85.57	82.34	
651	HT-49		80	3.0			L.E.V.	β M	.3204*	.3702*	.4095	.4277	.4732	.4942	.5467	.5710	
									63.63	55.07	49.78	47.66	43.08	41.25	37.29	35.70	

Composition: See Page 171  
 (\*) Extrapolated Values

T1 - 7 Al - 4 Mo

ROTARY BEAM BENDING  
 Miscellaneous

652	HT-50		167	80	1.0		S.E.V.	β M	.1437*	.1663*	.1842	.1924	.2131	.2226	.2465*	.2576*	
									140.6	121.5	109.7	105.0	94.87	90.80	82.00	78.48	

HT-49: 1700°F. 1 hr.. F.C. to 1100°F. A.C.  
 HT-50: 1725°F, 1 hr., W.Q.; 1200°F, 16 hrs.

Composition: See Page 171  
 (\*) Extrapolated Values

TI - 7 Al - 3 Mg

+Code No.	TEST CONDITIONS				FATIGUE STRENGTH DISTRIBUTIONS AND THEIR PARAMETERS											
	Heat Treat	Surf. Fin.	Freq.	Temp °F	K <sub>t</sub>	Other	DIST.	Param.	LIFE IN CYCLES							
									1x10 <sup>3</sup>	1x10 <sup>4</sup>	5x10 <sup>4</sup>	1x10 <sup>5</sup>	5x10 <sup>5</sup>	1x10 <sup>6</sup>	5x10 <sup>6</sup>	1x10 <sup>7</sup>

AXIAL (Completely Reversed)  
 Effect of Heat Treatment

653	HT-51	Mechanical Polish	60	600	1.0		Webull	b θ X <sub>o</sub>	9.886* 93.26 72.17	9.061* 84.63 66.96	9.715* 79.08 61.48	8.954* 76.80 60.94	8.942 71.76 56.96	9.691 69.70 54.22	8.189 65.12 52.72	10.44 63.25 48.20	
654	HT-52	Mechanical Polish	60	600	1.0		S.E.V.	β M	.4897* 91.88	.5456* 82.47	.5885* 76.47	.6079 74.02	.6557 68.64	.6773 66.44	.7305 61.60	.7547 59.63	

Effect of Test Temperature

655	HT-51	Mechanical Polish	60	80	1.0		Webull	b θ X <sub>o</sub>	1.562* 90.21 88.23	2.027* 87.46 85.18	1.977* 85.56 83.37	1.955 84.76 82.61	1.905 82.92 80.85	1.884 82.15 80.11	1.835 80.37 78.41	1.815* 79.61 77.69	
656	HT-51			60	400	1.0		Webull	b θ X <sub>o</sub>	1.658* 93.20 90.64	1.658* 86.78 84.39	1.658* 82.55 80.27	1.658* 80.79 78.57	1.070 76.81 75.17	1.658 75.22 73.15	1.658 71.55 69.58	1.658 70.03 68.10
657	HT-51	Mechanical Polish	60	600	1.0		Webull	b θ X <sub>o</sub>	9.886* 93.26 72.17	9.061* 84.63 66.96	9.715* 79.08 61.48	8.954* 76.80 60.94	8.942 71.76 56.96	9.691 69.70 54.22	8.189 65.12 52.72	10.44 63.25 48.20	
658	HT-51			60	800	1.0		S.E.V.	β M	.5348* 72.45	.5601* 69.17	.5785* 66.97	.5866* 66.05	.6059 63.95	.6143 63.06	.6345 61.06	.6435 60.21

HT-51: Aged 1560°F, in Argon, 0.5 hrs., A.C., 1020°F, 24 hrs., A.C.  
 HT-52: Annealed 1450°F, in Argon 1 hr., Slow Cool, 1 hr. at 100°F, heat to 1050°F, A.C.

Composition: See Page 171  
 (\*) Extrapolated Values

TH - 8 Al - 1 Mo - 1 V

S<sub>u</sub> = 147 ksi  
 S<sub>y</sub> = 133 ksi

Code No.	TEST CONDITIONS				FATIGUE STRENGTH DISTRIBUTIONS AND THEIR PARAMETERS												
	Heat Treat	Surf. Fin.	Freq. M	Temp M	R <sub>r</sub>	Other	DIST.	Param.	LIFE IN CYCLES								
									1x10 <sup>3</sup>	1x10 <sup>4</sup>	5x10 <sup>4</sup>	1x10 <sup>5</sup>	5x10 <sup>5</sup>	1x10 <sup>6</sup>	5x10 <sup>6</sup>	1x10 <sup>7</sup>	1x10 <sup>8</sup>

AXIAL (Completely Reversed)  
 Effect of Stress Concentration

Code No.	Heat Treat	Surf. Fin.	Freq. M	Temp M	R <sub>r</sub>	Other	DIST.	Param.	1x10 <sup>3</sup>	1x10 <sup>4</sup>	5x10 <sup>4</sup>	1x10 <sup>5</sup>	5x10 <sup>5</sup>	1x10 <sup>6</sup>	5x10 <sup>6</sup>	1x10 <sup>7</sup>	1x10 <sup>8</sup>
659	HT-53		20	80	1.0		Normal	n	5.955*	4.949	4.570	3.798	3.507	2.914*	2.691*		
660	HT-53		20	80	4.0		Wetbull	b θ K <sub>s</sub>	4.708*	4.523	4.543	4.250*	4.431*	4.541*	4.490*		
661	HT-53		20	550	1.0		S.E.V.	β M	.1111*	.1261	.1432	.1565	.1626	.1777	.1846*		
662	HT-53		20	550	4.0		Wetbull	b θ K <sub>s</sub>	8.086*	7.211*	7.788*	8.050*	7.417*				

Effect of Test Temperature

Code No.	Heat Treat	Surf. Fin.	Freq. M	Temp M	R <sub>r</sub>	Other	DIST.	Param.	1x10 <sup>3</sup>	1x10 <sup>4</sup>	5x10 <sup>4</sup>	1x10 <sup>5</sup>	5x10 <sup>5</sup>	1x10 <sup>6</sup>	5x10 <sup>6</sup>	1x10 <sup>7</sup>	1x10 <sup>8</sup>
663	HT-53		20	80	1.0		Normal	n	5.955*	4.949	4.570	3.798	3.507	2.914*	2.691*		
664	HT-53		20	550	1.0		S.E.V.	β M	.1111*	.1261	.1432	.1565	.1626	.1777	.1846*		

$S_u = 147 \text{ ksi}$   
 $S_y = 133 \text{ ksi}$

T1 - 8 Al - 1 Mo - 1 V (Cont'd)

Composition: See Page 171  
 (\*) Extrapolated Values

Code No.	TEST CONDITIONS			FATIGUE STRENGTH DISTRIBUTIONS AND THEIR PARAMETERS													
	Heat Treat	Surf. Fin.	Freq.	Temp.	$R_r$	Other	DIST.	Param.	LIFE IN CYCLES								
									$1 \times 10^3$	$1 \times 10^4$	$5 \times 10^4$	$1 \times 10^5$	$5 \times 10^5$	$1 \times 10^6$	$5 \times 10^6$	$1 \times 10^7$	$1 \times 10^8$

AXIAL (Completely Reversed)  
 Effect of Test Temperature

665	HT-53		20	80	4.0		Webull	$b$	4.708*	4.523	4.251	4.543	4.250*	4.431*	4.541*	4.490*	
							Webull	$\theta$	78.89	44.06	29.32	24.61	16.38	13.75	9.155	7.683	
							Webull	$\sigma_x$	55.06	31.20	21.20	17.40	11.84	9.807	6.473	5.454	
666	HT-53		20	550	4.0		Webull	$b$	8.086*	7.211*	7.427	7.788*	8.050*	7.417*			
							Webull	$\theta$	101.6	45.93	26.36	20.75	11.91	9.380			
							Webull	$\sigma_x$	79.17	36.78	20.97	16.32	9.290	7.464			

$S_u = 131 \text{ ksi}$   
 $S_y = 118 \text{ ksi}$

T1 - 3 Mn - 0.2 O2

Composition: See Page 171  
 (\*) Extrapolated Values

ROTARY BEAM BENDING

Effect of Stress Concentration

667	HT-54	Shaped Edges & Electropolish		80	1.0		Webull	$b$	8.947*	8.751	8.653	7.874	8.526	8.484	8.410	8.376	
							Webull	$\theta$	122.7	108.5	99.63	96.00	88.11	84.91	77.92	75.09	
							Webull	$\sigma_x$	72.90	65.35	60.38	61.26	53.86	52.05	48.00	46.37	
668	HT-54	Shaped Edges & Electropolish		80	3.0		S.F.V.	$b$	.2298*	.2685*	.2993	.3137	.3497	.3665	.4086	.4281	
							S.F.V.	$M$	60.55	51.82	46.49	44.36	39.79	37.97	34.06	32.50	

HT-53: 1450°F 8 hrs., F.C., 1850°F 5 min. A.C., 1375°F, 15 min. A.C.

HT-54: 1250°F 1 hr., F.C. to 900°F, A.C.

T1 - 3 Mn - 0.07 N2  
 Composition: See Page 171  
 (\*) Extrapolated Values

S<sub>u</sub> = 127 ksi  
 S<sub>y</sub> = 110 ksi

+Code No.	TEST CONDITIONS				FATIGUE STRENGTH DISTRIBUTIONS AND THEIR PARAMETERS												
	Heat Treat	Surt. Fin.	Freq.	Temp	K <sub>t</sub>	Other	DIST.	Param.	LIFE IN CYCLES								
									1x10 <sup>3</sup>	1x10 <sup>4</sup>	5x10 <sup>4</sup>	1x10 <sup>5</sup>	5x10 <sup>5</sup>	1x10 <sup>6</sup>	5x10 <sup>6</sup>	1x10 <sup>7</sup>	1x10 <sup>8</sup>

ROTARY BEAM BENDING  
 Effect of Stress Concentration

669	HT-54	Shaped Edges & Electropolish	80	1.0		Webull	β	8.722*	8.654*	7.999	8.652	7.998	8.652	7.998	8.652	9.304	7.998	
						Webull	q	105.3	98.65	94.24	92.41	88.28	86.57	88.28	86.57	82.71	81.09	
						Webull	α	81.03	76.06	74.16	71.26	69.47	66.76	69.47	66.76	62.48	63.81	
670	HT-54	Shaped Edges & Electropolish	80	3.0		Webull	β	2.775*	2.917	2.885	2.873	2.832	2.773	2.832	2.882	2.851	2.851	
						Webull	q	61.61	52.45	46.86	44.64	39.88	37.99	39.88	37.99	33.95	32.34	
						Webull	α	44.54	37.38	33.50	31.96	28.67	27.47	28.67	27.47	24.28	23.20	

S<sub>u</sub> = 126 ksi  
 S<sub>y</sub> = 111 ksi

T1 - 3 Mn - .2 C

Composition: See Page 171  
 (\*) Extrapolated Values

ROTARY BEAM BENDING  
 Effect of Stress Concentration

671	HT-54	Shaped Edges & Electropolish	80	1.0		S.E.V.	β	.2117*	.2254	.2355	.2400	.2508	.2556	.2671	.2722			
						S.E.V.	q	102.5	96.33	92.19	90.46	86.57	84.94	81.29	79.76			
672	HT-54	Shaped Edges & Electropolish	80	3.0		Webull	β	2.978*	2.969*	2.901	2.874	3.012	2.990	2.944	2.924			
						Webull	q	57.60	47.65	41.73	39.41	34.53	32.61	28.56	26.97			
						Webull	α	40.88	33.85	29.85	28.27	24.42	23.11	20.34	19.25			

Composition: See Page 171  
 (\*) Extrapolated Values

Ti - 3 Mn COMPLEX

S<sub>u</sub> = 126-149 ksi  
 S<sub>y</sub> = 111-125 ksi

Code No.	TEST CONDITIONS				FATIGUE STRENGTH DISTRIBUTIONS AND THEIR PARAMETERS												
	Heat Treat	Surt.	Fin.	Temp	K <sub>r</sub>	Other	DIST.	Param	LIFE IN CYCLES								
									1x10 <sup>3</sup>	1x10 <sup>4</sup>	5x10 <sup>4</sup>	1x10 <sup>5</sup>	5x10 <sup>5</sup>	1x10 <sup>6</sup>	5x10 <sup>6</sup>	1x10 <sup>7</sup>	1x10 <sup>8</sup>

ROTARY BEAM BENDING  
 Effect of Heat Treatment

673	HT-55	Mechanical & Electropolish		80	3.0		S.E.V.	β	.1159* 70.16	.1437 56.60	.1670 48.71	.1782 45.66	.2070 39.29	.2209 36.83	.2566 31.70	.2738 29.71	
674	HT-56			80	3.0		Webull	β θ X <sub>0</sub>	.9193* 63.56 54.39	1.235* 50.91 42.53	1.141 43.40 36.56	1.162 40.56 34.10	1.142 34.62 29.15	1.100 32.32 27.31	1.261 27.66 23.05	1.231 25.82 21.58	
675	HT-57			80	3.0		L.E.V.	β M	.2065* 68.70	.2441* 58.11	.2744 51.70	.2886 49.16	.3244 43.73	.3411 41.58	.3835 36.99	.4033 35.16	
676	HT-55	Shaped Edges & Electropolish		80	1.0		S.E.V.	β M	.1525* 100.9	.1683 91.46	.1804 85.37	.1858 82.88	.1991 77.36	.2051 75.09	.2197 70.09	.2263 68.04	
677	HT-57			80	1.0		Webull	β θ X <sub>0</sub>	2.997* 125.2 96.79	2.997* 112.4 86.87	2.997* 104.2 80.54	2.997 100.8 77.96	2.992 93.53 72.31	2.997 90.53 69.97	2.997 83.94 64.87	2.997 81.25 62.79	

HT-55: 1250°F, 1 hr., F.C. to 900°F, A.C.  
 HT-56: 1300°F, 1 hr., W.Q. to 1000°F, 2 hrs., A.C.  
 HT-57: 1500°F, 1 hr., W.Q.

Composition: See Page 171  
 (\*) Extrapolated Values

T1 - 3 Mn COMPLEX (Cont'd)

S<sub>u</sub> = 126-149 ksi  
 S<sub>y</sub> = 111-125 ksi

Code No.	TEST CONDITIONS				FATIGUE STRENGTH DISTRIBUTIONS AND THEIR PARAMETERS											
	Heat Treat	Surf. Treat	Pln.	Temp. °F	K <sub>t</sub>	Other	DIST.	Param. p	LIFE IN CYCLES							
								1x10 <sup>3</sup>	1x10 <sup>4</sup>	5x10 <sup>4</sup>	1x10 <sup>5</sup>	5x10 <sup>5</sup>	1x10 <sup>6</sup>	5x10 <sup>6</sup>	1x10 <sup>7</sup>	1x10 <sup>8</sup>

ROTARY BEAM BENDING  
 Effect of Heat Treatment

Code No.	Heat Treat	Surf. Treat	Pln.	Temp. °F	K <sub>t</sub>	Other	DIST.	Param. p	σ <sub>s</sub>	σ <sub>b</sub>	σ <sub>x</sub>	σ <sub>y</sub>	σ <sub>z</sub>	σ <sub>xy</sub>	σ <sub>yz</sub>	σ <sub>xz</sub>
678	HT-55		Mechanical & Electropolish	80	1.0		L.E.V. Weibull	3.117*	3.158	3.108	3.072	2.973	2.867	3.002	2.908	
								108.2	95.88	88.07	84.91	77.99	75.18	69.07	66.58	
								89.32	78.94	72.70	70.21	64.81	62.81	57.32	55.52	
679	HT-56		Mechanical & Electropolish	80	1.0		L.E.V. Weibull	.1141*	.1300*	.1424	.1481	.1622	.1687	.1848	.1922	
								115.6	101.5	92.67	89.10	81.34	78.21	71.39	68.64	

Effect of Stress Concentration

Code No.	Heat Treat	Surf. Treat	Pln.	Temp. °F	K <sub>t</sub>	Other	DIST.	Param. p	σ <sub>s</sub>	σ <sub>b</sub>	σ <sub>x</sub>	σ <sub>y</sub>	σ <sub>z</sub>	σ <sub>xy</sub>	σ <sub>yz</sub>	σ <sub>xz</sub>
680	HT-55		Mechanical & Electropolish	80	1.0		L.E.V. Weibull	3.117*	3.158	3.108	3.072	2.973	2.867	3.002	2.908	
								108.2	95.88	88.07	84.91	77.99	75.18	69.07	66.58	
								89.32	78.94	72.70	70.21	64.81	62.81	57.32	55.52	
681	HT-55		Mechanical & Electropolish	80	3.0		S.E.V. Weibull	.1158*	.1436	.1670	.1782	.2070	.2209	.2566	.2738	
								70.16	56.59	48.71	45.66	39.29	36.83	31.70	29.71	



S<sub>u</sub> = 126-149 ksi  
 S<sub>y</sub> = 111-125 ksi

Ti - 3 Mn COMPLEX (Cont'd)

Composition: See Page 171  
 (\*) Extrapolated Values

Code No.	TEST CONDITIONS		FATIGUE STRENGTH DISTRIBUTIONS AND THEIR PARAMETERS												
	Heat Treat	Surf. Fin.	Temp. °F	R <sub>r</sub>	Other	DIST.	LIFE IN CYCLES								
							1x10 <sup>3</sup>	1x10 <sup>4</sup>	5x10 <sup>4</sup>	1x10 <sup>5</sup>	5x10 <sup>5</sup>	1x10 <sup>6</sup>	5x10 <sup>6</sup>	1x10 <sup>7</sup>	1x10 <sup>8</sup>

ROTARY BEAM BENDING  
 Effect of Stress Concentration

Code No.	Heat Treat	Surf. Fin.	Temp. °F	R <sub>r</sub>	Other	DIST.	Param. q	1.141*	.1300*	.1424	.1481	.1622	.1687	.1848	.1922
682	HT-56	Mechanical & Electropolish	80	1.0		L.F.V.	M	115.6	101.5	92.67	89.10	81.34	78.21	71.39	68.64
683	HT-56		80	3.0		Wetbulb	q <sub>o</sub>	.9193*	1.235*	1.141	1.162	1.142	1.100	1.261	1.231
								63.56	50.91	43.40	40.56	34.62	32.32	27.66	25.82
								54.39	42.53	36.56	34.10	29.15	27.31	23.05	21.58

Effect of Surface Finish

Code No.	Heat Treat	Surf. Fin.	Temp. °F	R <sub>r</sub>	Other	DIST.	Param. q	.1525*	.1683	.1804	.1858	.1991	.2051	.2197	.2263
684	HT-55	M.P. & Sh.E. & E.P.	80	1.0		S.E.V.	M	100.9	91.46	85.37	82.87	77.36	75.09	70.09	68.04
685	HT-55		80	1.0		Wetbulb	q <sub>o</sub>	3.117*	3.158	3.108	3.072	2.973	2.867	3.002	2.908
								108.2	95.88	88.07	84.91	77.99	75.18	69.07	66.58
								89.32	78.94	72.70	70.21	64.81	62.81	57.32	55.52

Composition: See Page 171  
 (\*) Extrapolated Values

T1 - 3 Mn - .07 N<sub>2</sub> - .2 O<sub>2</sub> - .2 C

S<sub>u</sub> = 147 ksi  
 S<sub>y</sub> = 146 ksi

Code No	TEST CONDITIONS				FATIGUE STRENGTH DISTRIBUTIONS AND THEIR PARAMETERS												
	Heat Treat	Surf. Fin.	Freq.	Temp	R <sub>f</sub>	Other	DIST.	Pattern	LIFE IN CYCLES								
									1x10 <sup>3</sup>	1x10 <sup>4</sup>	5x10 <sup>4</sup>	1x10 <sup>5</sup>	5x10 <sup>5</sup>	1x10 <sup>6</sup>	5x10 <sup>6</sup>	1x10 <sup>7</sup>	1x10 <sup>8</sup>

ROTARY BEAM BENDING  
 Effect of Stress Concentration

686	HT-54	Shaped Edges & Electropolish		80	1.0					.9852*	.9852*	.9852*	.9852*	.9852	.9852	.9852	.9852
687	HT-54	Shaped Edges & Electropolish	σ	80	3.0				3.914*	3.449*	3.158	3.040	2.783	2.679	2.453	2.361	
			τ						53.87	47.48	43.46	41.84	38.31	36.88	33.76	32.50	
			σ <sub>W</sub>								86.15	84.82	81.80	80.54	77.68	76.47	
			τ <sub>W</sub>								75.75	74.58	71.93	70.82	68.30	67.24	

S<sub>u</sub> = 130 ksi  
 S<sub>y</sub> = 80 ksi

T1 - 4 Mn

Composition: See Page 171  
 (\*) Extrapolated Values

ROTARY BEAM BENDING  
 Miscellaneous

688		M.P.		80	1.0				.2239*	.2588	.2863	.2990	.3309	.3456	.3823	.3993*
									94.38	81.68	73.82	70.68	63.88	61.16	55.28	52.93
			L.F.V.													

S<sub>u</sub> = 135 ksi  
S<sub>y</sub> = 125 ksi

TI - 8 Mn

Composition: See Page 171  
(\* ) Extrapolated Values

Code No.	TEST CONDITIONS				FATIGUE STRENGTH DISTRIBUTIONS AND THEIR PARAMETERS											
	Heat Treat	Surf. Fin.	Freq.	Temp	R <sub>r</sub>	Other	DIST.	Param.	1x10 <sup>3</sup>	1x10 <sup>4</sup>	5x10 <sup>4</sup>	1x10 <sup>5</sup>	5x10 <sup>5</sup>	1x10 <sup>6</sup>	5x10 <sup>6</sup>	1x10 <sup>7</sup>

ROTARY BEAM BENDING  
Effect of Heat Treatment

689	HT-58		166	80	1.0		S.F.V.	M	.1310* 124.8	.1424* 114.9	.1509 108.4	.1547 105.7	.1639 99.79	.1681 97.33	.1781 91.85	.1826* 89.58	
690	HT-59		166	80	1.0		L.E.V.	M	.1437* 107.5	.1509* 102.4	.1561 99.03	.1583 97.60	.1638 94.34	.1662 92.98	.1719 89.88	.1745* 88.58	
691	HT-58	Polished - 8 RMS	166	80	3.0		Webull	Ø	1.379* 72.36	1.576* 59.86	1.769 52.44	1.797 49.53	1.534 43.34	1.685 40.94	1.408 35.83	1.765* 33.86	
692	HT-59	Polished - 8 RMS	166	80	3.0		L.E.V.	M	.3778* 72.78	.4672* 58.87	.5419 50.75	.5776 47.61	.6700 41.05	.7142* 38.50	.8284* 33.20	.8631* 31.14	

HT-58: Vacuum Annealed at 820°C, 19 ppm H<sub>2</sub>  
HT-59: Hydrogenated at 820°C, 368 ppm H<sub>2</sub>

Composition: See Page 171  
 (\*) Extrapolated Values

T1 - 8 Mn (Cont'd)

S<sub>u</sub> = 135 ksi  
 S<sub>y</sub> = 125 ksi

Code No.	TEST CONDITIONS				FATIGUE STRENGTH DISTRIBUTIONS AND THEIR PARAMETERS												
	Heat Treat	Surf. Fin.	Freq.	Temp.	R <sub>r</sub>	Other	Dist.	Param.	LIFE IN CYCLES								
									1x10 <sup>3</sup>	1x10 <sup>4</sup>	5x10 <sup>4</sup>	1x10 <sup>5</sup>	5x10 <sup>5</sup>	1x10 <sup>6</sup>	5x10 <sup>6</sup>	1x10 <sup>7</sup>	1x10 <sup>8</sup>

ROTARY BEAM BENDING  
 Effect of Stress Concentration

693	HT-58	Polished - 8 RMS								.1310*	.1424*	.1509	.1547	.1639	.1681	.1781	.1826*	
									124.8	114.9	108.4	105.7	99.79	97.33	91.85	89.58		
694	HT-58			166	80	1.0			1.379*	1.576*	1.769	1.797	1.534	1.685	1.408	1.765*		
									72.36	59.86	52.44	49.53	43.34	40.94	35.83	33.86		
									66.63	54.79	47.69	44.99	39.72	37.34	32.96	30.80		
695	HT-59			166	80	1.0			.1437*	.1509*	.1561	.1583	.1638	.1662	.1719	.1745*		
									107.5	102.4	99.03	97.60	94.34	92.98	89.88	88.58		
696	HT-59			166	80	3.0			.3778*	.4672*	.5419	.5776	.6700	.7142*	.8284*	.8831*		
									72.78	58.87	50.75	47.61	41.04	38.50	33.20	31.14		

T1 - 30 Mo

Composition: See Page 172  
(\* Extrapolated Values)

Code No.	TEST CONDITIONS				FATIGUE STRENGTH DISTRIBUTIONS AND THEIR PARAMETERS											
	Heat Treat	Surf. Fin.	Freq.	Temp °F	K <sub>t</sub>	Other	DIST.	Param.	LIFE IN CYCLES							
									1x10 <sup>3</sup>	1x10 <sup>4</sup>	5x10 <sup>4</sup>	1x10 <sup>5</sup>	5x10 <sup>5</sup>	1x10 <sup>6</sup>	5x10 <sup>6</sup>	1x10 <sup>7</sup>

ROTARY BEAM BENDING

Effect of Stress Concentration

Code No.	Heat Treat	Surf. Fin.	Freq.	Temp °F	K <sub>t</sub>	Other	DIST.	Param.	1x10 <sup>3</sup>	1x10 <sup>4</sup>	5x10 <sup>4</sup>	1x10 <sup>5</sup>	5x10 <sup>5</sup>	1x10 <sup>6</sup>	5x10 <sup>6</sup>	1x10 <sup>7</sup>	1x10 <sup>8</sup>
697	HT-60		100	80	2.5	Machine Notch	Weibull	b	3.814*	3.646*	3.817*	3.720	3.681	3.838*	3.711*	3.663*	
									55.49	43.56	36.79	34.20	28.88	26.85	22.68	21.08	
698	HT-60		100	80	3.0	Machine Notch	Weibull	b	40.89	32.50	27.10	25.38	21.49	19.75	16.84	15.71	
									1.175*	1.392	.9191	1.081	1.156	1.256*	1.345*	1.375*	
									68.51	46.20	34.67	30.77	23.31	20.71	15.70	13.94	
									54.41	35.62	28.12	24.68	18.55	16.29	12.19	10.77	

Effect of Surface Finish

Code No.	Heat Treat	Surf. Fin.	Freq.	Temp °F	K <sub>t</sub>	Other	DIST.	Param.	1x10 <sup>3</sup>	1x10 <sup>4</sup>	5x10 <sup>4</sup>	1x10 <sup>5</sup>	5x10 <sup>5</sup>	1x10 <sup>6</sup>	5x10 <sup>6</sup>	1x10 <sup>7</sup>	1x10 <sup>8</sup>
699	HT-3	Hand Finish	100	80	1.0		L.E.V.	β	.1202*	.1333*	.1432*	.1478	.1588	.1638	.1761	.1817	
									97.72	88.14	82.00	79.50	73.96	71.70	66.71	64.67	
700	HT-3	Ground Finish	100	80	1.0		S.F.V.	β	.1747*	.2035*	.2265*	.2372	.2640	.2764	.3077	.3222	
									88.06	75.57	67.90	64.84	58.26	55.64	50.00	47.74	
701	HT-3	Notch Rolled	100	80	3.0		L.E.V.	β	.2181*	.2503*	.2756	.2873	.3164	.3299*	.3633*	.3787*	
									131.6	114.6	104.1	99.88	90.70	87.01	79.01	75.80	
702	HT-3	Machined	100	80	3.0		Weibull	b	1.175*	1.392	.9191	1.081	1.156	1.256*	1.345*	1.375*	
									68.51	46.20	34.67	30.77	23.31	20.71	15.70	13.94	
									54.41	35.62	28.12	24.68	18.55	16.29	12.19	10.77	

HT-60: Annealed 450°F, 0.5 hrs., Shot peened with .010 Steel Shot to Almen #10

Composition: See Page 172  
 (\*) Extrapolated Values

Ti - 13 V - 11 Cr - 3 Al

S<sub>y</sub> = 174-203 ksi  
 S<sub>u</sub> = 156-186 ksi

Code No.	TEST CONDITIONS				FATIGUE STRENGTH DISTRIBUTIONS AND THEIR PARAMETERS											
	Heat Treat	Surf. Fin.	Req. Temp.	K <sub>t</sub>	Other	DIST.	Param.	LIFE IN CYCLES								
								1x10 <sup>3</sup>	1x10 <sup>4</sup>	5x10 <sup>4</sup>	1x10 <sup>5</sup>	5x10 <sup>5</sup>	1x10 <sup>6</sup>	5x10 <sup>6</sup>	1x10 <sup>7</sup>	1x10 <sup>8</sup>

AXIAL (Completely Reversed)  
 Effect of Heat Treatment

Code No.	Heat Treat	Surf. Fin.	Req. Temp.	K <sub>t</sub>	Other	DIST.	Param.	1x10 <sup>3</sup>	1x10 <sup>4</sup>	5x10 <sup>4</sup>	1x10 <sup>5</sup>	5x10 <sup>5</sup>	1x10 <sup>6</sup>	5x10 <sup>6</sup>	1x10 <sup>7</sup>	1x10 <sup>8</sup>
703	HT-61		60	1.0		S.E.V.	M β	.1544* 135.0	.2754* 75.72	.4127 50.54	.4912 42.46	.7360* 28.34	.8760* 23.81			
704	HT-62		60	1.0		Webull	q X <sup>o</sup>	4.531* 77.02 42.07	4.474* 59.79 32.95	4.342 50.09 28.16	4.301 46.41 26.25	4.217 38.88 22.27	4.185 36.02 20.73	4.119* 30.18 17.53	4.094* 27.96 16.30	
705	HT-61	Ground Edges	60	1.0		Webull	b X <sup>o</sup>	2.142* 56.74 46.39	2.142* 53.63 43.85	2.142 51.56 41.15	2.142 50.69 41.44	2.142 48.74 39.84	2.141 47.92 39.18	2.164 46.07 37.61	2.173 45.29 36.96	
706	HT-62		60	1.0		L.E.V.	M β	.4171* 69.46	.4699* 61.66	.5107 56.74	.5293 54.74	.5752 50.37	.5962 48.59	.6480 44.71	.6716 43.14	
707	HT-61		60	1.0		Webull	q X <sup>o</sup>	2.558* 60.63 48.95	2.528* 58.16 47.05	2.506 56.50 45.77	2.498 55.80 45.22	2.478 54.20 43.99	2.469 53.53 43.46	2.450 52.00 42.27	2.442 51.35 41.77	
708	HT-62		60	1.0		S.E.V.	M β	.1240* 68.76	.1384* 61.60	.1495 57.04	.1545 55.18	.1669 51.10	.1725 49.43	.1863 45.78	.1926* 44.28	

HT-61: Solution H.T. 1450°F, 30 min., A.C., Aged 900°F, 12 hrs.

HT-62: Solution H.T. 1450°F, 30 min., A.C.

Composition: See Page 172  
 (\*) Extrapolated Values

TI - 13 V - 11 Cr - 3 Al (Cont'd)

S<sub>u</sub> = 174-203 ksi  
 S<sub>y</sub> = 156-186 ksi

Code No.	TEST CONDITIONS				FATIGUE STRENGTH DISTRIBUTIONS AND THEIR PARAMETERS												
	Heat Treat	Surf. Fin.	Freq.	Temp	R <sub>r</sub>	Other	DIST.	Form	LIFE IN CYCLES								
									1x10 <sup>3</sup>	1x10 <sup>4</sup>	5x10 <sup>4</sup>	1x10 <sup>5</sup>	5x10 <sup>5</sup>	1x10 <sup>6</sup>	5x10 <sup>6</sup>	1x10 <sup>7</sup>	1x10 <sup>8</sup>

AXIAL (Completely Reversed)  
 Effect of Stress Concentration

Code No.	Heat Treat	Surf. Fin.	Freq.	Temp	R <sub>r</sub>	Other	DIST.	Form	1x10 <sup>3</sup>	1x10 <sup>4</sup>	5x10 <sup>4</sup>	1x10 <sup>5</sup>	5x10 <sup>5</sup>	1x10 <sup>6</sup>	5x10 <sup>6</sup>	1x10 <sup>7</sup>	1x10 <sup>8</sup>
709	HT-62	Ground Edges	60	75	1.0	Shear Specimens	Wetbulb	q	4.531*	4.474*	4.342	4.301	4.217	4.185	4.119*	4.094*	
								q	77.02	59.79	50.09	46.41	38.88	36.02	30.18	27.96	
								X <sub>0</sub>	42.07	32.95	28.16	26.25	22.27	20.73	17.53	16.30	
710	HT-62	Ground Edges	60	75	3.0	Shear Specimens	Wetbulb	b	3.841*	3.598*	3.778	3.768	3.746	3.737	3.717	3.709	
								q	29.23	26.28	24.40	23.63	21.94	21.25	19.73	19.10	
								X <sub>0</sub>	19.57	18.04	16.44	15.94	14.83	14.38	13.38	12.96	
711	HT-63	As Machined	60	75	1.0	Lathe Turned and Bored Bar	Wetbulb	b	1.785*	1.848*	1.658	1.673	1.711	1.725	1.757	1.770	
								q	101.7	89.85	82.26	79.24	72.64	69.97	64.14	61.78	
								X <sub>0</sub>	81.18	71.31	66.31	63.79	58.31	56.10	51.29	49.36	
712	HT-63	As Machined	60	75	3.0	Lathe Turned and Bored Bar	Normal	n	2.749*	2.625*	2.543	2.508	2.429	2.395	2.320	2.288	
								q	39.56	37.79	36.59	36.09	34.95	34.47	33.39	32.93	
713	HT-63	As Machined	60	600	1.0	Lathe Turned and Bored Bar	Wetbulb	b	1.050*	.6147*	.8082	.8706	.9993	1.050	.6426	.7471*	
								q	102.6	91.03	84.41	81.67	75.62	73.15	67.15	65.02	
								X <sub>0</sub>	93.81	84.83	78.07	75.32	69.30	66.86	62.52	60.30	
714	HT-63	As Machined	60	600	3.0	Lathe Turned and Bored Bar	Wetbulb	b	1.504*	1.513*	1.521	1.523	1.524	1.524	1.524	1.524	
								q	44.70	42.64	41.26	40.67	39.35	38.70	37.53	37.00	
								X <sub>0</sub>	35.65	33.97	32.84	32.37	31.32	30.87	29.87	29.44	

HT-63: Solution H.T. 1400°F, 30 min., A.C., Aged 900°F, 72 hrs. in Argon

$S_u = 174-203 \text{ ksi}$   
 $S_y = 156-186 \text{ ksi}$   
 T1 - 13 V - 11 Cr - 3 Al (Cont'd)  
 Composition: See Page 172  
 (\*) Extrapolated Values

+Code No.	TEST CONDITIONS				FATIGUE STRENGTH DISTRIBUTIONS AND THEIR PARAMETERS											
	Heat Treat	Surt. Fin.	Freq.	Temp °F	K <sub>t</sub>	Other	DISTR.	PARAM.	LIFE IN CYCLES							
									1x10 <sup>3</sup>	1x10 <sup>4</sup>	5x10 <sup>4</sup>	1x10 <sup>5</sup>	5x10 <sup>5</sup>	1x10 <sup>6</sup>	5x10 <sup>6</sup>	1x10 <sup>7</sup>

AXIAL (Completely Reversed)  
Effect of Stress Concentration

Code No.	Heat Treat	Surt. Fin.	Freq.	Temp °F	K <sub>t</sub>	Other	DISTR.	PARAM.	LIFE IN CYCLES							
									1x10 <sup>3</sup>	1x10 <sup>4</sup>	5x10 <sup>4</sup>	1x10 <sup>5</sup>	5x10 <sup>5</sup>	1x10 <sup>6</sup>	5x10 <sup>6</sup>	1x10 <sup>7</sup>
715	HT-63	Ground Edges	60	75	1.0	Sheet Specimens	Weibull S.E.V.	M	0.2773*	0.3172*	0.3485	0.3629	0.3986	0.4151	0.4560	0.4749
									107.1	93.69	85.28	81.90	74.55	71.59	65.17	62.59
716	HT-63	Ground Edges	60	75	3.0	Sheet Specimens	Weibull S.E.V.	p	5.290*	5.271*	5.259	5.242	5.198	5.179	5.138	5.122
									46.86	43.26	40.91	39.94	37.77	36.88	34.88	34.05
								σ <sub>x</sub>	27.06	25.04	23.72	23.20	22.05	21.57	20.50	20.05

Effect of Test Temperature

Code No.	Heat Treat	Surt. Fin.	Freq.	Temp °F	K <sub>t</sub>	Other	DISTR.	PARAM.	LIFE IN CYCLES							
									1x10 <sup>3</sup>	1x10 <sup>4</sup>	5x10 <sup>4</sup>	1x10 <sup>5</sup>	5x10 <sup>5</sup>	1x10 <sup>6</sup>	5x10 <sup>6</sup>	1x10 <sup>7</sup>
717	HT-61	Ground Edges	60	75	1.0	Sheet Specimens	Weibull S.E.V.	M	0.1544*	0.2754*	0.4127	0.4912	0.7360*	0.8760*		
									135.0	75.72	50.54	42.46	28.34	23.81		
718	HT-61	Ground Edges	60	600	1.0	Sheet Specimens	Weibull S.E.V.	p	2.142*	2.142*	2.142	2.142	2.142	2.141	2.164	2.173
									56.74	53.63	51.56	50.69	48.74	47.92	46.07	45.29
								σ <sub>x</sub>	46.39	43.85	42.15	41.44	39.84	39.18	37.61	36.96
719	HT-61	Ground Edges	60	800	1.0	Sheet Specimens	Weibull S.E.V.	p	2.558*	2.528*	2.506	2.498	2.478	2.469	2.450	2.442
									60.63	58.16	56.50	55.80	54.20	53.53	52.00	51.35
								σ <sub>x</sub>	48.94	47.05	45.77	45.22	43.99	43.46	42.27	41.77



Composition: See Page 172  
 (\*) Extrapolated Values

T1 - 13 V - 11 Cr - 3 Al (Cont'd)

S<sub>u</sub> = 174-203 ksi  
 S<sub>y</sub> = 156-186 ksi

Code No.	TEST CONDITIONS			FATIGUE STRENGTH DISTRIBUTIONS AND THEIR PARAMETERS								
	Heat Treat	Surr. Fin.	Temp. °F	1x10 <sup>3</sup>	1x10 <sup>4</sup>	5x10 <sup>4</sup>	1x10 <sup>5</sup>	5x10 <sup>5</sup>	1x10 <sup>6</sup>	5x10 <sup>6</sup>	1x10 <sup>7</sup>	1x10 <sup>8</sup>

AXIAL (Completely Reversed)  
 Effect of Test Temperature

Code No.	Heat Treat	Surr. Fin.	Temp. °F	R <sub>r</sub>	Other	DISP. Pattern	LIFE IN CYCLES								
							1x10 <sup>3</sup>	1x10 <sup>4</sup>	5x10 <sup>4</sup>	1x10 <sup>5</sup>	5x10 <sup>5</sup>	1x10 <sup>6</sup>	5x10 <sup>6</sup>	1x10 <sup>7</sup>	1x10 <sup>8</sup>
720	HT-62		75	1.0	Sheet Specimens	Webull	b	4.531*	4.474*	4.342	4.301	4.217	4.185	4.119*	4.094*
721	HT-62		600	1.0	Sheet Specimens	L.E.V.	B	.4171*	.4699*	.5107	.5293	.5752	.5962	.6480	.6716
722	HT-62		800	1.0	Sheet Specimens	L.E.V.	B	.1240*	.1384*	.1495	.1545	.1669	.1725	.1863	.1926*
723	HT-63		75	1.0	Lathe Turned and Bored Bar	Webull	b	1.785*	1.848*	1.658	1.673	1.711	1.725	1.757	1.770
724	HT-63		600	1.0	Lathe Turned and Bored Bar	Webull	b	101.7	89.85	82.26	79.24	72.64	69.97	64.14	61.78
725	HT-63		800	1.0	Lathe Turned and Bored Bar	S.E.V.	B	81.18	71.31	66.31	63.79	58.31	56.10	51.29	49.35

S<sub>y</sub> = 174-203 ksi  
 S<sub>u</sub> = 156-186 ksi

T1 - 13 V - 11 Cr - 3 Al (Cont'd)

Composition: See Page 172  
 (\*) Extrapolated Values

Code No.	TEST CONDITIONS				FATIGUE STRENGTH DISTRIBUTIONS AND THEIR PARAMETERS												
	Heat Treat	Surf. Fin.	Preq.	Temp.	R <sub>f</sub>	Other	DIST.	Param.	LIFE IN CYCLES								
									1x10 <sup>3</sup>	1x10 <sup>4</sup>	5x10 <sup>4</sup>	1x10 <sup>5</sup>	5x10 <sup>5</sup>	1x10 <sup>6</sup>	5x10 <sup>6</sup>	1x10 <sup>7</sup>	1x10 <sup>8</sup>

AXIAL (Completely Reversed)  
 Effect of Test Temperature

Code No.	Heat Treat	Surf. Fin.	Preq.	Temp.	R <sub>f</sub>	Other	DIST.	Param.	1x10 <sup>3</sup>	1x10 <sup>4</sup>	5x10 <sup>4</sup>	1x10 <sup>5</sup>	5x10 <sup>5</sup>	1x10 <sup>6</sup>	5x10 <sup>6</sup>	1x10 <sup>7</sup>	1x10 <sup>8</sup>
726	HT-63	As Machined	60	75	3.0	Lathe Turned and Bored Bar	Normal	1.0	2.749*	2.625*	2.543	2.508	2.429	2.395	2.320	2.288	
									39.56	37.79	36.59	36.09	34.95	34.47	33.39	32.93	
727	HT-63	As Machined	60	600	3.0	Lathe Turned and Bored Bar	Wetbulb	0.9	1.504*	1.513*	1.521	1.523	1.524	1.524	1.524	1.524	
									44.70	42.64	41.26	40.67	39.35	38.70	37.53	37.00	
									35.65	33.97	32.84	32.37	31.32	30.87	29.87	29.44	
728	HT-63	As Machined	60	800	3.0	Lathe Turned and Bored Bar	Wetbulb	0.9	5.290*	5.271*	5.259	5.242	5.198	5.179	5.138	5.122	
									46.86	43.26	40.91	39.94	37.77	36.88	34.88	34.05	
									27.06	25.04	23.72	23.20	22.05	21.57	20.50	20.05	

S<sub>u</sub> = 107-186 ksi  
 S<sub>y</sub> = 78-173 ksi

T<sub>1</sub> - 16 V - 2.5 S<sub>n</sub>

Composition: See Page 172  
 (\*) Extrapolated Values

Code No.	TEST CONDITIONS				FATIGUE STRENGTH DISTRIBUTIONS AND THEIR PARAMETERS									
	Heat Treat	Surf. Fin.	Temp. °F	R <sub>r</sub>	Other	LIFE IN CYCLES								
						1x10 <sup>3</sup>	1x10 <sup>4</sup>	5x10 <sup>4</sup>	1x10 <sup>5</sup>	5x10 <sup>5</sup>	1x10 <sup>6</sup>	5x10 <sup>6</sup>	1x10 <sup>7</sup>	1x10 <sup>8</sup>

AXIAL (Completely Reversed)  
 Effect of Test Temperature

Code No.	Heat Treat	Surf. Fin.	Temp. °F	R <sub>r</sub>	Other	Dist.	Notes	1x10 <sup>3</sup>	1x10 <sup>4</sup>	5x10 <sup>4</sup>	1x10 <sup>5</sup>	5x10 <sup>5</sup>	1x10 <sup>6</sup>	5x10 <sup>6</sup>	1x10 <sup>7</sup>	1x10 <sup>8</sup>
729	1400°F, 20 min., 990°F, 6 hrs.	Ground and Milled Edges	30	80		Normal		19.37	14.95	12.47	11.54	9.629	8.907	7.432	6.875*	
			30	80		Normal		113.0	87.24	72.79	67.33	56.18	51.97	43.36	40.11	
730			30	80		L.F.V.		.1070*	.1401	.1691	.1834	.2214	.2401	.2899*	.3144*	
			30	80		L.F.V.		65.86	50.31	41.68	38.43	31.84	29.36	24.32	22.43	
731			30	400		S.E.V.		.0725*	.1025	.1306	.1450	.1847	.2050	.2611	.2898*	
			30	400		S.E.V.		114.3	80.88	63.49	57.21	44.91	40.47	31.77	28.62	
732			30	400		Normal		9.378*	6.805	5.439	4.939	3.947	3.584	2.864*	2.601*	
			30	400		Normal		68.14	49.45	39.52	35.88	28.68	26.04	20.81	18.90	
733			30	600		L.F.V.		.0819*	.1004	.1158	.1231	.1420	.1510	.1741	.1851*	
			30	600		L.F.V.		68.65	56.00	48.56	45.68	39.61	37.26	32.31	30.39	
734			30	600		Normal		2.288*	2.288	2.288	2.241	2.286	2.249	2.176	2.292*	
			30	600		Normal		64.26	47.78	38.84	35.51	28.87	26.40	21.45	19.63	
			30	600		Normal		43.18	32.11	26.10	24.02	19.41	17.83	14.64	13.18	

S<sub>y</sub> = 107-186 ksi  
 S<sub>u</sub> = 78-173 ksi

T1 - 16 V - 2.5 Sn (Cont'd)

Composition: See Page 172  
 (\*) Extrapolated Values

Code No.	TEST CONDITIONS				FATIGUE STRENGTH DISTRIBUTIONS AND THEIR PARAMETERS										
	Heat Treat	Surf. Fin.	Temp. Req.	R <sub>r</sub>	Other	DIST.	LIFE IN CYCLES								
							1x10 <sup>3</sup>	1x10 <sup>4</sup>	5x10 <sup>4</sup>	1x10 <sup>5</sup>	5x10 <sup>5</sup>	1x10 <sup>6</sup>	5x10 <sup>6</sup>	1x10 <sup>7</sup>	1x10 <sup>8</sup>

AXIAL (Completely Reversed)  
 Effect of Stress Concentration

Code No.	Heat Treat	Surf. Fin.	Temp. Req.	R <sub>r</sub>	Other	DIST.	.020 in. Sheet								
							3.448*	3.394	3.364	3.353	3.330	3.324	3.324	3.324	3.204*
735	1400° F, 20 min., 990° F, 6 hrs.	Ground and Milled Edges	30	800	1.0	Wetbulb	90.71	67.90	55.45	50.82	41.51	38.04	31.07	28.48	
736			30	800	2.8	Wetbulb	38.79	29.48	24.27	22.31	18.34	16.83	13.75	12.60	
737			30	900	1.0	Wetbulb	67.80	46.28	35.44	31.59	24.19	21.56	16.51	14.71	
738			30	900	2.8	Normal	29.44	20.39	15.69	13.99	10.89	9.799	7.633	6.845	
			30	900	1.0	Wetbulb	4.748*	4.690	4.654	4.623	4.484	4.456	4.396	4.372*	
			30	900	2.8	Wetbulb	74.21	60.44	52.36	49.22	42.64	40.08	34.72	32.64	
			30	900	2.8	Normal	34.65	28.53	24.88	23.53	20.90	19.75	17.29	16.33	
			30	900	2.8	Normal	7.876*	5.714	4.565	4.145	3.312	3.007	2.403*	2.181*	
			30	900	2.8	Normal	52.21	37.88	30.27	27.48	21.96	19.93	15.93	14.46	

Composition: See Page 172  
 (\*) Extrapolated Values

T1 - 16 V - 2.5 Sn (Cont'd)

S<sub>u</sub> = 107-186 ksi  
 S<sub>y</sub> = 78-173 ksi

Code No.	TEST CONDITIONS				Other	DIST.	Param.	FATIGUE STRENGTH DISTRIBUTIONS AND THEIR PARAMETERS								
	Heat Treat	Surf. Fin.	Freq.	Temp °F				K <sub>t</sub>	LIFE IN CYCLES							
								1x10 <sup>3</sup>	1x10 <sup>4</sup>	5x10 <sup>4</sup>	1x10 <sup>5</sup>	5x10 <sup>5</sup>	1x10 <sup>6</sup>	5x10 <sup>6</sup>	1x10 <sup>7</sup>	1x10 <sup>8</sup>

AXIAL (Completely Reversed)  
 Effect of Stress Concentration

Code No.	Heat Treat	Surf. Fin.	Freq.	Temp °F	K <sub>t</sub>	Other	DIST.	Param.	1x10 <sup>3</sup>	1x10 <sup>4</sup>	5x10 <sup>4</sup>	1x10 <sup>5</sup>	5x10 <sup>5</sup>	1x10 <sup>6</sup>	5x10 <sup>6</sup>	1x10 <sup>7</sup>	1x10 <sup>8</sup>
739	1410°F, 25 min., 990°F, 4 hrs.	Ground and Milled Edges	30	80	1.0	.063 in. Sheet	Normal	n <sub>0</sub>	20.62* 108.3	16.81 88.34	14.57 76.56	13.70 71.99	11.87 62.40	11.16 58.67	9.678 50.85	9.100* 47.81	
740			30	80	2.8		Normal	n <sub>0</sub>	9.099* 66.81	7.465 54.81	6.500 47.72	6.124 44.96	5.332 39.15	5.024 36.89	4.375 32.12	4.121 30.26	
741			30	400	1.0		Wetbull	b q	1.863* 107.5 74.31	1.826 80.62 55.96	1.829 65.91 45.73	1.854 60.44 41.80	1.760 49.38 34.57	1.779 45.28 31.62	1.817 37.02 25.73	1.831* 33.95 23.55	
742			30	400	2.8		Wetbull	q	3.623* 73.45 32.44	3.581 57.69 25.76	3.557 48.73 21.90	3.548 45.32 20.41	3.528 38.28 17.33	3.523 35.60 16.14	3.523 30.07 13.63	3.523* 27.97 12.68	
743			30	600	1.0		Wetbull	q	3.593* 103.1 63.85	3.593 80.40 49.75	3.711 67.54 41.15	3.667 62.65 38.39	3.740 52.63 31.94	3.705 48.82 29.77	3.635 41.00 25.23	3.609* 38.03 23.48	
744			30	600	2.8		Wetbull	b q	2.746* 80.17 52.90	2.746 58.18 38.39	2.746 46.50 30.68	2.746 42.23 27.86	2.746 33.75 22.27	2.746 30.65 20.22	2.746 24.49 16.16	2.746* 22.24 14.67	

T1 - 16 V - 2.5 Sn (Cont'd) Composition: See Page 172  
 (\*) Extrapolated Values

S<sub>u</sub> = 107-186 ksi  
 S<sub>y</sub> = 78-173 ksi

Code No.	TEST CONDITIONS		FATIGUE STRENGTH DISTRIBUTIONS AND THEIR PARAMETERS														
	Heat Treat	Surf. Fin.	Freq.	Temp.	R <sub>r</sub>	Other	DIST.	Param.	LIFE IN CYCLES								
									1x10 <sup>3</sup>	1x10 <sup>4</sup>	5x10 <sup>4</sup>	1x10 <sup>5</sup>	5x10 <sup>5</sup>	1x10 <sup>6</sup>	5x10 <sup>6</sup>	1x10 <sup>7</sup>	1x10 <sup>8</sup>

AXIAL (Completely Reversed)  
 Effect of Stress Concentration

Code No.	Heat Treat	Surf. Fin.	Freq.	Temp.	R <sub>r</sub>	Other	DIST.	Param.	1x10 <sup>3</sup>	1x10 <sup>4</sup>	5x10 <sup>4</sup>	1x10 <sup>5</sup>	5x10 <sup>5</sup>	1x10 <sup>6</sup>	5x10 <sup>6</sup>	1x10 <sup>7</sup>	1x10 <sup>8</sup>
745	1410°F, 25 min., 990°F, 4 hrs.	Ground and Milled Edges	30	800	1.0	.063 in. Sheet	Wetbull L.R.V.	M	.1023* 83.18	.1286 66.18	.1509 56.40	.1617 52.65	.1897 44.87	.2032 41.89	.2385 35.70	.2555* 33.33	
746			30	800	2.8		Wetbull	θ	1.779* 67.11	1.779 48.86	1.779 39.14	1.759 35.56	1.786 28.4	1.754 25.89	1.689 20.72	1.782* 18.85	
747			30	900	1.0		Wetbull	θ	1.206* 80.72	1.265 62.37	1.297 52.07	1.309 48.18	1.312 40.21	1.312 37.19	1.312 31.04	1.312 28.71	
748			30	900	2.8		Wetbull	θ	1.396* 58.83	1.476 42.31	1.515 33.60	1.529 30.42	1.552 24.15	1.552 21.86	1.552 17.35	1.552 15.70	

Composition: See Page 172  
 (\*) Extrapolated Values

T1 - 16 V - 2.5 Sn (Cont'd)

$S_u$  = 107-186 ksi  
 $S_y$  = 78-173 ksi

A Code No.	TEST CONDITIONS				FATIGUE STRENGTH DISTRIBUTIONS AND THEIR PARAMETERS											
	Heat Treat	Surf. Fin.	Temp. Req.	$R^*$	Other	Dist.	Param.	LIFE IN CYCLES								
								1x10 <sup>3</sup>	1x10 <sup>4</sup>	5x10 <sup>4</sup>	1x10 <sup>5</sup>	5x10 <sup>5</sup>	1x10 <sup>6</sup>	5x10 <sup>6</sup>	1x10 <sup>7</sup>	1x10 <sup>8</sup>

AXIAL (Completely Reversed)  
 Effect of Stress Concentration

A Code No.	TEST CONDITIONS				FATIGUE STRENGTH DISTRIBUTIONS AND THEIR PARAMETERS											
	Heat Treat	Surf. Fin.	Temp. Req.	$R^*$	Other	Dist.	Param.	LIFE IN CYCLES								
								1x10 <sup>3</sup>	1x10 <sup>4</sup>	5x10 <sup>4</sup>	1x10 <sup>5</sup>	5x10 <sup>5</sup>	1x10 <sup>6</sup>	5x10 <sup>6</sup>	1x10 <sup>7</sup>	1x10 <sup>8</sup>
749	1410°F, 30 min., 975°F, 4 hrs.	Ground and Milled Edges	30	1.0		L.R.V.	M	.0867*	.1157	.1415	.1543	.1888	.2059	.2519	.2748	
				1.0	.125 in. Sheet	L.R.V.	M	118.9	89.13	72.86	66.80	54.61	50.07	40.93	37.52	
750			30	2.8		Webull	$\theta$	2.396*	2.396*	2.396*	2.396	2.396	2.396	2.522*	2.478*	
				2.8		Webull	$\theta$	72.31	55.72	46.43	42.93	35.77	33.07	27.58	25.49	
751			30	1.0		L.R.V.	M	.0863	.1167	.1442	.1580	.1951	.2137	.2640	.2892*	
				1.0		L.R.V.	M	125.9	93.13	75.39	68.83	55.72	50.88	41.19	37.61	
752			30	2.8		Webull	$\theta$	1.866*	1.181	1.249	1.329	1.410	1.375	1.465*	1.395*	
				2.8		Webull	$\theta$	80.75	55.93	43.45	38.99	30.30	27.16	21.11	18.92	
753			30	1.0		Webull	$\theta$	65.68	47.76	36.97	33.03	25.53	22.94	17.72	15.96	
				1.0		Webull	$\theta$	.9699*	1.183	1.797	.9807	.9301	1.307	.9532	1.157*	
754			30	2.8		L.R.V.	M	.2243*	.2835*	.3341	.3585	.4224	.4533	.5340*	.5730*	
				2.8		L.R.V.	M	49.82	39.41	33.45	31.17	26.46	24.66	20.93	19.51	

Composition: See Page 172  
 (\*) Extrapolated Values

T1 - 16 - 2.5 Sn (Cont'd)

S<sub>u</sub> = 107-186 ksi  
 S<sub>y</sub> = 78-173 ksi

Code No.	TEST CONDITIONS				FATIGUE STRENGTH DISTRIBUTIONS AND THEIR PARAMETERS												
	Heat Treat	Surf. Fin.	Freq.	Temp.	R <sub>r</sub>	Other	DIST.	Param.	LIFE IN CYCLES								
									1x10 <sup>3</sup>	1x10 <sup>4</sup>	5x10 <sup>4</sup>	1x10 <sup>5</sup>	5x10 <sup>5</sup>	1x10 <sup>6</sup>	5x10 <sup>6</sup>	1x10 <sup>7</sup>	1x10 <sup>8</sup>

AXIAL (Completely Reversed)  
 Effect of Stress Concentration

755	1410°F, 30 min., 975°F, 4 hrs.	Ground and Milled Edges	30	800	1.0	.125 in. Sheet	Webull	b	2.407*	2.381	2.406	2.378	2.424	2.404	2.363	2.349	
756			30	800	2.8		Webull	b	3.188*	3.263	3.261	3.262	3.262	3.137	3.199*	3.157*	
757			30	900	1.0		L.R.V. Webull	b	.5505*	.8293	.1104	.1249	.1663	.1882	.2506*	.2835*	
758			30	900	2.8		Webull	b	1.838*	1.945*	1.820*	1.841	1.884	1.900	1.933*	1.946*	
								q	43.02	34.18	29.07	27.12	23.08	21.54	18.33	17.10	
								q	37.44	25.48	21.96	20.44	17.32	16.13	13.68	12.75	



Composition: See Page 172  
 (\*) Extrapolated Values

T1 - 16 V - 2.5 Sn(Cont'd.)

S<sub>u</sub> = 107-186 ksi  
 S<sub>y</sub> = 78-173 ksi

Code No.	TEST CONDITIONS				FATIGUE STRENGTH DISTRIBUTIONS AND THEIR PARAMETERS								
	Heat Treat	Surf. Fin.	Freq.	Temp	1x10 <sup>3</sup>	1x10 <sup>4</sup>	5x10 <sup>4</sup>	1x10 <sup>5</sup>	5x10 <sup>5</sup>	1x10 <sup>6</sup>	5x10 <sup>6</sup>	1x10 <sup>7</sup>	1x10 <sup>8</sup>

AXIAL (Completely Reversed)  
 Effect of Test Temperature

Code No.	Heat Treat	Surf. Fin.	Freq.	Temp	R <sub>r</sub>	Other	Dist.	σ	LIFE IN CYCLES							
									1x10 <sup>3</sup>	1x10 <sup>4</sup>	5x10 <sup>4</sup>	1x10 <sup>5</sup>	5x10 <sup>5</sup>	1x10 <sup>6</sup>	5x10 <sup>6</sup>	1x10 <sup>7</sup>
759	1400°F, 20 min., 990°F, 6 hrs.	Ground and Milled Edges	30	80	1.0	.020 In. Sheet	Normal	σ	19.37*	14.95	12.47	11.54	9.629	8.907	7.432	6.875*
760			30	400	1.0		S.E.V.	β M	.0725*	.1025	.1306	.1450	.1847	.2050	.2611	.2898*
761			30	600	1.0		L.F.V.	β M	113.0	87.24	72.79	67.33	56.18	51.97	43.36	40.11
762			30	800	1.0		Wetbulb	σ <sub>q</sub>	114.3	80.88	63.49	57.21	44.91	40.47	31.77	28.62
763			30	900	1.0		Wetbulb	σ <sub>q</sub>	68.65	56.00	48.56	45.68	39.61	37.26	32.31	30.39

Composition: See Page 172  
 (\*) Extrapolated Values

Ti - 16 V - 2.5 Sn (Cont'd)

S<sub>u</sub> = 107-186 ksi  
 S<sub>y</sub> = 78-173 ksi

Code No.	TEST CONDITIONS		FATIGUE STRENGTH DISTRIBUTIONS AND THEIR PARAMETERS													
	Heat Treat	Surf. Fin.	Freq.	Temp °F	K <sub>t</sub>	Other	DIST.	Param.	LIFE IN CYCLES							
									1x10 <sup>3</sup>	1x10 <sup>4</sup>	5x10 <sup>4</sup>	1x10 <sup>5</sup>	5x10 <sup>5</sup>	1x10 <sup>6</sup>	5x10 <sup>6</sup>	1x10 <sup>7</sup>

AXIAL (Completely Reversed)  
 Effect of Test Temperature

Code No.	Heat Treat	Surf. Fin.	Freq.	Temp °F	K <sub>t</sub>	Other	DIST.	Param.	LIFE IN CYCLES							
									1x10 <sup>3</sup>	1x10 <sup>4</sup>	5x10 <sup>4</sup>	1x10 <sup>5</sup>	5x10 <sup>5</sup>	1x10 <sup>6</sup>	5x10 <sup>6</sup>	1x10 <sup>7</sup>
764	1400°F, 20 min., 990°F, 6 hrs.	Milled Edges	30	80	2.8	.020 in. Sheet	Normal L.E.V.	σ	1070*	1401	1691	1834	2214	2401	2899*	3144*
									65.86	50.31	41.68	38.43	31.84	29.36	24.32	22.43
765	1400°F, 20 min., 990°F, 6 hrs.	Milled Edges	30	400	2.8	.020 in. Sheet	Normal L.E.V.	σ	9.378*	6.805	5.439	4.939	3.947	3.584	2.864*	2.601*
									68.14	49.45	39.52	35.88	28.68	26.04	20.81	18.90
766	1400°F, 20 min., 990°F, 6 hrs.	Milled Edges	30	600	2.8	.020 in. Sheet	Weibull	σ	2.288*	2.288	2.288	2.241	2.286	2.249	2.176	2.292*
									64.26	47.78	38.84	35.51	28.87	26.40	21.45	19.63
767	1400°F, 20 min., 990°F, 6 hrs.	Milled Edges	30	800	2.8	.020 in. Sheet	Weibull	σ	43.18	32.11	26.10	24.02	19.41	17.83	14.64	13.18
									3.433*	3.382	3.364	3.364	3.303	3.269	3.204*	3.181*
768	1400°F, 20 min., 990°F, 6 hrs.	Milled Edges	30	900	2.8	.020 in. Sheet	Normal Weibull	σ	67.80	46.28	35.44	31.59	24.19	21.56	16.51	14.71
									29.44	20.39	15.69	13.99	10.89	9.799	7.633	6.843
768	1400°F, 20 min., 990°F, 6 hrs.	Milled Edges	30	900	2.8	.020 in. Sheet	Normal Weibull	σ	7.876*	5.714	4.565	4.145	3.312	3.007	2.403*	2.181*
									52.21	37.88	30.27	27.48	21.96	19.93	15.93	14.46

S<sub>u</sub> = 107-186 ksi  
 S<sub>y</sub> = 78-173 ksi

Ti - 16 V - 2.5 Sn (Cont'd)

Composition: See Page 172  
 (\*) Extrapolated Values

Code No.	TEST CONDITIONS				Other	DISTR.	Param	FATIGUE STRENGTH DISTRIBUTIONS AND THEIR PARAMETERS								
	Heat Treat	Surf. Fin.	Freq.	Temp.				R <sub>f</sub>	LIFE IN CYCLES							
								1x10 <sup>3</sup>	1x10 <sup>4</sup>	5x10 <sup>4</sup>	1x10 <sup>5</sup>	5x10 <sup>5</sup>	1x10 <sup>6</sup>	5x10 <sup>6</sup>	1x10 <sup>7</sup>	1x10 <sup>8</sup>

AXIAL (Completely Reversed)  
 Effect of Test Temperature

Code No.	Heat Treat	Surf. Fin.	Freq.	Temp.	R <sub>f</sub>	Other	DISTR.	Param	1x10 <sup>3</sup>	1x10 <sup>4</sup>	5x10 <sup>4</sup>	1x10 <sup>5</sup>	5x10 <sup>5</sup>	1x10 <sup>6</sup>	5x10 <sup>6</sup>	1x10 <sup>7</sup>	1x10 <sup>8</sup>
769	1410°F, 25 min., 990°F, 4 hrs.	Ground and Milled Edges	30	80	1.0	.063 in. Sheet	Normal	σ <sub>t</sub>	20.62*	16.81	14.57	13.70	11.87	11.16	9.678	9.100*	
									108.3	88.34	76.56	71.99	62.40	58.67	50.85	47.81	
770			30	400	1.0		Webull	b	1.863*	1.826	1.829	1.854	1.760	1.779	1.817	1.831*	
								θ	107.5	80.62	65.91	60.44	49.38	45.28	37.02	33.95	
								X <sub>σ</sub>	74.31	55.96	45.73	41.80	34.57	31.62	25.73	23.55	
771			30	600	1.0		Webull	b	3.593*	3.593	3.711	3.667	3.740	3.705	3.635	3.609*	
								θ	103.1	80.40	67.54	62.65	52.63	48.82	41.00	38.03	
								X <sub>σ</sub>	63.85	49.75	41.15	38.39	31.94	29.77	25.23	23.48	
772			30	800	1.0		L.E.V.	S	.1023*	.1286	.1509	.1617	.1897	.2032	.2385	.2555*	
								M	83.18	66.18	56.40	52.65	44.87	41.89	35.70	33.33	
773			30	900	1.0		Webull	b	1.206*	1.265	1.297	1.309	1.312	1.312	1.312	1.312	1.312
								θ	80.72	62.37	52.07	48.18	40.21	37.19	31.04	28.71	
								X <sub>σ</sub>	56.92	43.65	36.28	33.51	27.96	25.86	21.58	19.96	

S<sub>n</sub> = 107-186 ksi  
 S<sub>y</sub> = 78-173 ksi

T1 - 16 V - 2.5 Sn (Cont'd)

Composition: See Page 172  
 (\*) Extrapolated Values

+Code No.	TEST CONDITIONS				FATIGUE STRENGTH DISTRIBUTIONS AND THEIR PARAMETERS												
	Heat Treat	Surf. Fin.	Freq.	Temp.	R <sub>r</sub>	Other	DIST.	Param.	LIFE IN CYCLES								
									1x10 <sup>3</sup>	1x10 <sup>4</sup>	5x10 <sup>4</sup>	1x10 <sup>5</sup>	5x10 <sup>5</sup>	1x10 <sup>6</sup>	5x10 <sup>6</sup>	1x10 <sup>7</sup>	1x10 <sup>8</sup>

AXIAL (Completely Reversed)  
 Effect of Test Temperature

Code No.	Heat Treat	Surf. Fin.	Freq.	Temp.	R <sub>r</sub>	Other	DIST.	Param.	1x10 <sup>3</sup>	1x10 <sup>4</sup>	5x10 <sup>4</sup>	1x10 <sup>5</sup>	5x10 <sup>5</sup>	1x10 <sup>6</sup>	5x10 <sup>6</sup>	1x10 <sup>7</sup>	1x10 <sup>8</sup>
774	1410°F, 25 min., 990°F, 4 hrs.	Milled Edges	30	80	2.8	.063 in. Sheet	Normal	9.099*	7.465	6.500	6.124	5.332	5.024	4.375	4.121		
								66.81	54.81	47.72	44.96	39.15	36.89	32.12	30.26		
775			30	400	2.8		Webull	3.623*	3.581	3.557	3.548	3.528	3.523	3.523	3.523*		
								73.45	57.69	48.73	45.32	38.28	35.60	30.07	27.97		
								32.44	25.76	21.90	20.41	17.33	16.14	13.63	12.68		
776			30	600	2.8		Webull	2.746*	2.746	2.746	2.746	2.746	2.746	2.746	2.746*		
								80.17	58.18	46.50	42.23	33.75	30.65	24.49	22.24		
								52.90	38.39	30.68	27.86	22.27	20.22	16.16	14.67		
777			30	800	2.8		Webull	1.779*	1.779	1.779	1.759	1.786	1.754	1.689	1.782*		
								67.11	48.86	39.14	35.56	28.49	25.89	20.72	18.85		
								43.28	31.51	25.24	23.01	18.35	16.76	13.56	12.15		
778			30	900	2.8		Webull	1.396*	1.476	1.515	1.529	1.552	1.552	1.552	1.552*		
								58.83	42.31	33.60	30.42	24.15	21.86	17.35	15.70		
								39.49	28.04	22.11	19.97	15.79	14.29	11.34	10.27		

Composition: See Page 172  
 (\*) Extrapolated Values

T1 - 16 V - 2.5 Sn (Cont'd)

S<sub>u</sub> = 107-186 ksi  
 S<sub>y</sub> = 78-173 ksi

Code No.	TEST CONDITIONS			FATIGUE STRENGTH DISTRIBUTIONS AND THEIR PARAMETERS													
	Heat Treat	Surf. Fin.	Freq.	Temp	K <sub>t</sub>	Other	DIST.	Param.	LIFE IN CYCLES								
									1x10 <sup>3</sup>	1x10 <sup>4</sup>	5x10 <sup>4</sup>	1x10 <sup>5</sup>	5x10 <sup>5</sup>	1x10 <sup>6</sup>	5x10 <sup>6</sup>	1x10 <sup>7</sup>	1x10 <sup>8</sup>

AXIAL (Completely Reversed)  
 Effect of Test Temperature

Code No.	Heat Treat	Surf. Fin.	Freq.	Temp	K <sub>t</sub>	Other	DIST.	Param.	1x10 <sup>3</sup>	1x10 <sup>4</sup>	5x10 <sup>4</sup>	1x10 <sup>5</sup>	5x10 <sup>5</sup>	1x10 <sup>6</sup>	5x10 <sup>6</sup>	1x10 <sup>7</sup>	1x10 <sup>8</sup>
779	1410°F, 30 min., 975°F, 4 hrs.	Ground and Milled Edges	30	80	1.0	.125 in. Sheet	L.E.V.	M	.0867*	.1157	.1415	.1543	.1888	.2059	.2519	.2748	
							L.E.V.	M	118.9	89.13	72.86	66.80	54.61	50.07	40.93	37.52	
780			30	400	1.0		L.E.V.	M	.0863	.1167	.1442	.1580	.1951	.2137	.2640	.2892*	
							L.E.V.	M	125.9	93.13	75.39	68.83	55.72	50.88	41.19	37.61	
781			30	600	1.0		Webull	q	.9699*	1.183	1.797	.9807	.9301	1.307	.9532	1.157*	
							Webull	q	100.7	76.63	63.72	57.98	47.78	44.19	36.25	33.44	
							Webull	q	86.58	65.00	51.13	49.81	41.14	37.12	31.18	28.42	
782			30	800	1.0		Webull	q	2.407*	2.381	2.406	2.378	2.424	2.404	2.363	2.349	
							Webull	q	106.7	77.42	61.87	56.16	44.89	40.76	32.56	29.55	
							Webull	q	60.86	44.38	35.29	32.21	25.51	23.25	18.73	17.05	
783			30	900	1.0		L.E.V.	M	.5505*	.8293	.1104	.1249	.1663	.1882	.2506*	.2835*	
							L.E.V.	M	76.66	50.89	38.21	33.78	25.37	22.42	16.84	14.88	

Composition: See Page 172  
 (\*) Extrapolated Values

T1 - 16 V - 2.5 Sn (Cont'd)

S<sub>u</sub> = 107-186 ksi  
 S<sub>y</sub> = 78-173 ksi

Code No.	TEST CONDITIONS				FATIGUE STRENGTH DISTRIBUTIONS AND THEIR PARAMETERS										
	Heat Treat	Surt. Fin.	Req. Temp	K <sub>t</sub>	Other	DIST.	LIFE IN CYCLES								
							1x10 <sup>3</sup>	1x10 <sup>4</sup>	5x10 <sup>4</sup>	1x10 <sup>5</sup>	5x10 <sup>5</sup>	1x10 <sup>6</sup>	5x10 <sup>6</sup>	1x10 <sup>7</sup>	1x10 <sup>8</sup>

AXIAL (Completely Reversed)  
 Effect of Test Temperature

Code No.	TEST CONDITIONS				FATIGUE STRENGTH DISTRIBUTIONS AND THEIR PARAMETERS										
	Heat Treat	Surt. Fin.	Req. Temp	K <sub>t</sub>	Other	DIST.	LIFE IN CYCLES								
							1x10 <sup>3</sup>	1x10 <sup>4</sup>	5x10 <sup>4</sup>	1x10 <sup>5</sup>	5x10 <sup>5</sup>	1x10 <sup>6</sup>	5x10 <sup>6</sup>	1x10 <sup>7</sup>	1x10 <sup>8</sup>
784	1410°F, 30 min., 975°F, 4 hrs.	Milled Edges	30	80	2.8	Webull	2.396*	2.396*	2.396*	2.396	2.396	2.396	2.396*	2.478*	
						b	72.31	55.72	46.43	42.93	35.77	33.07	27.58	25.49	
						σ	49.83	38.39	31.99	29.58	24.65	22.79	18.69	17.38	
						X <sub>0</sub>									
785			30	400	2.8	Webull	1.866*	1.181	1.249	1.329	1.410	1.375	1.465*	1.395*	
						b	80.75	55.93	43.45	38.99	30.30	27.16	21.11	18.92	
						σ	65.68	47.76	36.97	33.03	25.53	22.94	17.72	15.96	
						X <sub>0</sub>									
786			30	600	2.8	L.E.V. Webull	.2243*	.2836*	.3341	.3585	.4224	.4533	.5340*	.5730*	
						K	49.82	39.41	33.45	31.17	26.46	24.66	20.93	19.51	
						β									
787			30	800	2.8	Webull	3.188*	3.263	3.261	3.262	3.262	3.137	3.199*	3.157*	
						b	74.40	53.45	42.41	38.38	30.45	27.56	21.87	19.79	
						σ	41.80	29.62	23.51	21.28	16.88	15.62	12.26	11.18	
						X <sub>0</sub>									
788			30	900	2.8	Webull	1.838*	1.945*	1.820*	1.841	1.884	1.900	1.933*	1.946*	
						b	43.02	34.18	29.07	27.12	23.08	21.54	18.33	17.10	
						σ	32.44	25.48	21.96	20.44	17.32	16.13	13.68	12.75	
						X <sub>0</sub>									

**A-1.5.7 Other Non-Ferrous Alloys**

BERILCO #25

Composition: See Page 172  
 (\*) Extrapolated Values

+Code No	TEST CONDITIONS				FATIGUE STRENGTH DISTRIBUTIONS AND THEIR PARAMETERS											
	Heat Treat	Surt. Fln.	Freq.	Temp °F	K <sub>t</sub>	Other	DIST.	Param.	LIFE IN CYCLES							
									1x10 <sup>3</sup>	1x10 <sup>4</sup>	5x10 <sup>4</sup>	1x10 <sup>5</sup>	5x10 <sup>5</sup>	1x10 <sup>6</sup>	5x10 <sup>6</sup>	1x10 <sup>7</sup>

ROTARY BEAM BENDING

Miscellaneous

789	HT-64	R.R. Moore	1.0	80	200	Webull	b	θ	X <sub>o</sub>	5.740*	6.119*	5.640*	5.850*	5.817	5.787	5.685	5.865	5.899*
										89.01	74.41	65.64	62.19	54.87	51.99	45.86	43.46	36.33
										51.53	41.37	38.40	35.60	31.51	29.96	26.71	24.83	20.68

COMMERCIALLY PURE LEAD

Composition: See Page 172  
 (\*) Extrapolated Values

CANTILEVER BEAM BENDING (Completely Reversed)

Effect of Impurities

790	99.915% Lead	Webull	b	θ	X <sub>o</sub>	99.915% Lead	1.0	80	200	Webull	b	θ	X <sub>o</sub>	3.867*	3.867	3.867*	3.867*	3.867*																	
														3.755	1.440	.7375	.5527																		
														3.492	1.339	.6857	.5139																		
791	99.915% Lead	Webull	b	θ	X <sub>o</sub>	99.915% Lead	1.0	80	200	Webull	b	θ	X <sub>o</sub>	.6869*	.6869	.6869*	.9777*	.9777*																	
														3.786	1.920	1.194	.9775																		
														3.548	1.799	1.119	.9050																		

HT-64: Age hardened 600°F, 3 hrs., A.C.



Composition: See Page 172  
 (\*) Extrapolated Values

0.5 T1 MOLYBDENUM

S<sub>u</sub> = 139 ksi  
 S<sub>y</sub> = 111 ksi

Code No.	TEST CONDITIONS				FATIGUE STRENGTH DISTRIBUTIONS AND THEIR PARAMETERS												
	Heat Treat	Surf. Fin.	Freq.	Temp °F	K <sub>t</sub>	Other	DIST.	Param.	LIFE IN CYCLES								
									1x10 <sup>2</sup>	1x10 <sup>4</sup>	5x10 <sup>4</sup>	1x10 <sup>5</sup>	5x10 <sup>5</sup>	1x10 <sup>6</sup>	5x10 <sup>6</sup>	1x10 <sup>7</sup>	1x10 <sup>8</sup>

PLATE BENDING (Completely Reversed)  
 Miscellaneous

792		Ground Edges		80	1.0	Hot Rolled	Normal	σ	4.483*	4.095*	3.939	3.598	3.460	3.161	3.040*	2.671*
									137.0	125.1	120.3	109.9	105.7	96.59	92.90	81.62

S<sub>u</sub> = 93-103 ksi  
 S<sub>y</sub> = 87-96 ksi

COMMERCIALLY PURE TANTALUM

Composition: See Page 172  
 (\*) Extrapolated Values

Code No.	TEST CONDITIONS				FATIGUE STRENGTH DISTRIBUTIONS AND THEIR PARAMETERS											
	Heat Treat	Surf. Fin.	Freq.	Temp °K	R <sub>r</sub>	Other	Dist.	Param	LIFE IN CYCLES							
									1x10 <sup>3</sup>	1x10 <sup>4</sup>	5x10 <sup>4</sup>	1x10 <sup>5</sup>	5x10 <sup>5</sup>	1x10 <sup>6</sup>	5x10 <sup>6</sup>	1x10 <sup>7</sup>

AXIAL (Completely Reversed)  
 Effect of Heat Treatment

Code No.	Heat Treat	Surf. Fin.	Temp °K	R <sub>r</sub>	Other	Dist.	Param	1x10 <sup>3</sup>	1x10 <sup>4</sup>	5x10 <sup>4</sup>	1x10 <sup>5</sup>	5x10 <sup>5</sup>	1x10 <sup>6</sup>	5x10 <sup>6</sup>	1x10 <sup>7</sup>	1x10 <sup>8</sup>
793	Annealed 1650°C	Polished	80	1.0		S.F.V.	β		.7785*	.9551*	1.043*	1.280	1.398	1.715	1.873*	2.510*
							M	101.1	82.43	75.47	61.51	56.32	45.89	42.02	31.36	
794	Annealed 2320°C	Polished	80	1.0		L.E.V.	β	.5483*	.6135	.6864	.7425	.7680	.8307	.8593*	.9614*	
							M	50.93	47.08	45.52	40.68	37.61	36.36	32.50		
795		Polished	80	1.0		S.F.V.	β		.2189*	.2357	.2796	.3009	.3570*	.3843*		
							M		88.54	82.26	69.34	64.42	54.30	50.45		
796	HT-65	Polished	80	1.0	295 ppm H <sub>2</sub>	Webull	β	.9122	.9571	.9627	.9627	.9627	.9627*	.9627*	.9627*	.9627*
							θ	36.33	26.31	20.96	15.14	13.72	10.93	9.915	7.161	5.437
							γ	27.88	20.00	15.91	11.49	10.42	8.303	7.528		

Effect of Test Temperature

Code No.	Heat Treat	Surf. Fin.	Temp °K	R <sub>r</sub>	Other	Dist.	Param	1x10 <sup>3</sup>	1x10 <sup>4</sup>	5x10 <sup>4</sup>	1x10 <sup>5</sup>	5x10 <sup>5</sup>	1x10 <sup>6</sup>	5x10 <sup>6</sup>	1x10 <sup>7</sup>	1x10 <sup>8</sup>
797	Annealed 1650°C	Polished	80	1.0		S.F.V.	β	.7785*	.9551*	1.043*	1.280	1.398	1.715	1.873*	2.510*	
							M	101.1	82.43	75.47	61.51	56.32	45.89	42.02	31.36	
798	Annealed 1650°C	Polished	550	1.0		S.F.V.	β	.3173*	.3780*	.4272*	.5090	.5365	.6064*	.6392*	.7615*	
							M	100.0	83.95	74.28	62.35	59.15	52.33	49.65	41.67	

HT-65: Wrought, Stress relieved, 1000°C, 1 hr.

Composition: See Page 172  
(\*) Extrapolated Values

10 W - TANTALUM

S<sub>u</sub> = 127-141 ksi  
S<sub>y</sub> = 125-130 ksi

Code No.	TEST CONDITIONS				FATIGUE STRENGTH DISTRIBUTIONS AND THEIR PARAMETERS												
	Heat Treat	Surf. Fin.	Freq.	Temp.	R <sub>r</sub>	Other	DIST.	Param.	LIFE IN CYCLES								
									1x10 <sup>3</sup>	1x10 <sup>4</sup>	5x10 <sup>4</sup>	1x10 <sup>5</sup>	5x10 <sup>5</sup>	1x10 <sup>6</sup>	5x10 <sup>6</sup>	1x10 <sup>7</sup>	1x10 <sup>8</sup>

PLATE BENDING (Completely Reversed)  
Effect of Grain Direction

Code No.	Heat Treat	Surf. Fin.	Freq.	Temp.	R <sub>r</sub>	Other	DIST.	Param.	1.807*	1.280	1.820	1.819*	1.500*	1.820*	1.206*	1.778*
799	Cold Rolled	Shaped and Ground Edges		80	1.0	Longt. Bending	Normal Weibull	σ <sub>x</sub> φ <sub>q</sub>	125.3	103.7	95.73	79.30	73.07	60.56	55.78	42.65
800			80			Transv. Bending	Normal Weibull	σ <sub>y</sub> φ <sub>q</sub>	119.9	100.0	91.59	75.87	70.28	57.94	53.86	40.83
			80						6.265*	5.413	5.083	4.392	4.124	3.563	3.346*	2.715*
									113.8	98.39	92.39	79.83	74.96	64.77	60.82	49.35

S<sub>u</sub> = 195 ksi

Composition: See Page 172  
(\*) Extrapolated Values

PURE TUNGSTEN

TRANSVERSE PLATE BENDING (Completely Reversed)  
Miscellaneous

Code No.	Heat Treat	Surf. Fin.	Freq.	Temp.	R <sub>r</sub>	Other	DIST.	Param.	.2347*	.2661*	.2904	.3292	.3419	.3732	.3875	.4393*
801		Ground Edges		80	1.0		L.F.V.	M	190.8	168.3	154.2	136.0	131.0	120.0	115.6	101.9

PAGES 351, 352  
ARE  
MISSING  
IN  
ORIGINAL  
DOCUMENT

## A-2.1 A METHOD FOR INTERPOLATING INTERFERENCE VALUES

The values of Interference given in Appendix 2 are highly non-linear. As a result, when interpolation is required to obtain an interference value, a higher order interpolating procedure will be more accurate than a linear one.

One method for interpolating at a higher order is to construct what is called an "interpolating polynomial." The interpolating polynomial gives an  $n$ th order interpolation using  $n + 1$  interference values from the table.

### A-2.1.1 Higher Order Interpolation Procedure

There are several types of interpolating polynomials, one of the easiest to use is constructed using Neville's Algorithm.<sup>(16)</sup> This method and the symbols used are:

- $X$  is the value of an interference parameter which does not appear in the interference tables.
- $X_0, X_1, \dots, X_n$  are any  $n+1$  consecutive values of the interference parameters which do appear in the interference tables.
- $d=0, 1, \dots, n$  are the consecutive indices.
- $P_{k,0}(X)$   $k=0, 1, \dots, n$  are the  $n+1$  interference values corresponding to the values of the interference parameter  $X_0, X_1, \dots, X_n$ .
- $P_{n,n}(X)$  is the desired  $n$ th order interpolated interference value for the interference parameter,  $X$ .

$P_{n,n}(X)$  is the last entry of the triangular array of polynomials  $P_{k,d}(X)$ , (as shown in Table A-2.1 where  $P_{k,d}(X)$  is defined as:

$$P_{k,d+1}(X) = \frac{(X_k - X) P_{k-1,d}(X) - (X_{k-d-1} - X) P_{k,d}(X)}{X_k - X_{k-d-1}}$$

$$\text{where } d = 0, 1, \dots, n$$

$$k = d+1, d+2, \dots, n.$$

It is important to note that the value of the interference parameter,  $X$ , for which the interference must be interpolated can lie anywhere in the interval  $X_0 \leq X \leq X_n$ . However, the value of  $X$  may also lie outside this interval, in which case the problem becomes one of extrapolation rather than interpolation.

When the interpolation is required for only one interference parameter, say  $X$ , it is called one-way interpolation; and when the interpolation is done for, say two or three parameters,  $X$  and  $Y$  or  $X, Y$ , and  $Z$ , it is called two-way and three-way interpolation respectively.

		Interference Values From Table				
		0	1	2 . . . . . n		
Values of the Interference Parameter	$X_k$					
	$X_0$	$P_{0,0}$				
	$X_1$	$P_{1,0}$	$P_{1,1}(X)$			
	$X_2$	$P_{2,0}$	$P_{2,1}(X)$	$P_{2,2}(X)$		
	.	.	.	.		
	$X_n$	$P_{n,0}$	$P_{n,1}(X)$	$P_{n,2}(X) \cdot \cdot \cdot P_{n,n}(X)$		} nth order interpolated value of interference at X

Table A-2.1 Construction of the Triangular Array of Polynomials for nth Order

Interference Parameter	Interference Values From Table			Interference When $\alpha=.025$ and $\gamma=-2.5$
$-y=X_k$	(d=0) $P_{k,0}$	(d=1) $P_{k,1}$	(d=2) $P_{k,2}$	(d=3) $P_{k,3}$
$X_0=1.0$	$P_{0,0}=.3079$			
$X_1=2.0$	$P_{1,0}=.1266$	$P_{1,1}=.0359$		
$X_2=3.0$	$P_{2,0}=.0486$	$P_{2,1}=.0876$	$P_{2,2}=.0747$	
$X_3=4.0$	$P_{3,0}=.0182$	$P_{3,1}=.0638$	$P_{3,2}=.0817$	$P_{3,3}=.0782$

Table A-2.2 Polynomials for Third Order Interpolation

The following examples will illustrate the application of this higher order interpolating method for one, two, and three-way interpolation problems. In the example chosen, linear, third order and fifth order interpolations were used but this method applies equally well to even and odd order interpolations.

#### A-2.1.2 Example Problem for One-Way Interpolation

A particular part has Smallest Extreme Value distributed strength with parameters  $(\beta, M)$  and is subjected to Normally distributed stresses with parameters  $(\mu, \sigma)$ . The calculated interference parameters are:

$$\alpha = \beta\sigma = .025$$

$$\gamma = \beta(\mu - M) = -2.50$$

What is the % Interference?

From the tables in Appendix 2 on Page 422, it is noted that  $\alpha = .025$  appears in the table but  $\gamma = -2.5$  does not; therefore, the value of interference must be interpolated. The values of interference as read from the above tables are:

<u>-<math>\gamma</math></u>	<u>Interference</u> <u>When <math>\alpha = .025</math></u>
2.0	.1266
3.0	.0486

#### Linear Interpolation:

If the quick and easy linear interpolation is used, the interference corresponding to  $\alpha = .025$  and  $\gamma = -2.5$  is found as:

$$\begin{aligned} \text{Interference} &= .1266 + \frac{(.1266 - .0486)}{(2.0 - 3.0)} (3.0 - 2.5) \\ &= .1266 - .0390 \\ &= .0876 \end{aligned}$$

$$\text{or Percent Interference} = 8.76\%$$

#### Third Order Interpolation:

Using a third order interpolation, by constructing the appropriate polynomials,  $P_{k,d}(X)$ , the value of  $P_{3,3}(X)$  is the interpolated value of interference. Where  $P_{3,3}(X)$  is calculated as follows and the results are tabulated in Table A-2.2:

$$P_{k,d+1}(X) = \frac{(X_k - X)P_{k-1,d}(X) - (X_{k-d-1} - X)P_{k,d}(X)}{X_k - X_{k-d-1}}$$

$$P_{1,1}(2.5) = \frac{(2 - 2.5)(.3079) - (1 - 2.5)(.1266)}{2 - 1} = .0359$$

$$P_{2,1}(2.5) = \frac{(3-2.5)(.1266) - (2-2.5)(.0486)}{3 - 2} = .0876$$

$$P_{3,1}(2.5) = \frac{(4-2.5)(.0486) - (3-2.5)(.0182)}{4 - 3} = .0638$$

$$P_{2,2}(2.5) = \frac{(3-2.5)(.0359) - (1-2.5)(.0876)}{3 - 1} = .0747$$

$$P_{3,2}(2.5) = \frac{(4-2.5)(.0876) - (2-2.5)(.0638)}{4 - 2} = .0817$$

$$\text{Interference} = P_{3,3}(2.5) = \frac{(4-2.5)(.0747) - (1-2.5)(.0817)}{4 - 1} = .0782$$

or Percent Interference = 7.82%

Thus, it can be seen that the third order interpolation gives significantly more accurate results than the linear interpolation.

#### Fifth Order Interpolation:

Using a fifth order interpolation, by constructing the appropriate polynomials ( $P_{k,d}(X)$ ), the value of  $P_{5,5}(X)$  is the interpolated value of interference where  $P_{5,5}(X)$  is calculated as follows and the results are tabulated in Table A-2.3.

$$P_{1,1}(2.5) = \frac{(1-2.5)(.6321) - (0-2.5)(.3079)}{1 - 0} = -.17840$$

$$P_{2,1}(2.5) = \frac{(2-2.5)(.3079) - (1-2.5)(.1266)}{2 - 1} = 0.03595$$

$$P_{3,1}(2.5) = \frac{(3-2.5)(.1266) - (2-2.5)(.0486)}{3 - 2} = 0.08760$$

$$P_{4,1}(2.5) = \frac{(4-2.5)(.0486) - (3-2.5)(.0182)}{4 - 3} = 0.06380$$

$$P_{5,1}(2.5) = \frac{(5-2.5)(.0182) - (4-2.5)(.0067)}{5 - 4} = 0.03545$$

$$P_{2,2}(2.5) = \frac{(2-2.5)(-.17840) - (0-2.5)(.03595)}{2 - 0} = .0895375$$

$$P_{3,2}(2.5) = \frac{(3-2.5)(.03595) - (1-2.5)(.08760)}{3 - 1} = .0746875$$

$$P_{4,2}(2.5) = \frac{(4-2.5)(.08760) - (2-2.5)(.06380)}{4 - 2} = .0816500$$

$$P_{5,2}(2.5) = \frac{(5-2.5)(.06380) - (3-2.5)(.03545)}{5 - 3} = .0708875$$



$\alpha = .025$		Interference Values From Table					Interference When $\alpha = .025$ and $\gamma = -2.5$
Interference Parameter	$(d=0)$ $P_{k,0}$	$(d=1)$ $P_{k,1}$	$(d=2)$ $P_{k,2}$	$(d=3)$ $P_{k,3}$	$(d=4)$ $P_{k,4}$		
$- \gamma = X_k$							$(d=5)$ $P_{k,5}$
$X_0 = 0$	$P_{0,0} = .6321$						
$X_1 = 1.0$	$P_{1,0} = .3079$	$P_{1,1} = -.17840$					
$X_2 = 2.0$	$P_{2,0} = .1266$	$P_{2,1} = .03595$	$P_{2,2} = .0895375$				
$(X=2.5)$ $X_3 = 3.0$	$P_{3,0} = .0486$	$P_{3,1} = .08760$	$P_{3,2} = .0746875$	$P_{3,3} = .0771625$			
$X_4 = 4.0$	$P_{4,0} = .0182$	$P_{4,1} = .06380$	$P_{4,2} = .0816500$	$P_{4,3} = .07816875$	$P_{4,4} = .0777914$		
$X_5 = 5.0$	$P_{5,0} = .0067$	$P_{5,1} = .03545$	$P_{5,2} = .0708875$	$P_{5,3} = .07985625$	$P_{5,4} = .07880156$	$P_{5,5} = .0783$	

Table A-2.3 Polynomials for Fifth Order Interpolation

$$P_{3,3}(2.5) = \frac{(3-2.5)(.0895375) - (0-2.5)(.0746875)}{3-0} = .0771625$$

$$P_{4,3}(2.5) = \frac{(4-2.5)(.0746875) - (1-2.5)(.0816500)}{4-1} = .07816875$$

$$P_{5,3}(2.5) = \frac{(5-2.5)(.0816500) - (2-2.5)(.0708875)}{5-2} = .07985625$$

$$P_{4,4}(2.5) = \frac{(4-2.5)(.0771625) - (0-2.5)(.07816875)}{4-0} = .0777914$$

$$P_{5,4}(2.5) = \frac{(5-2.5)(.07816875) - (1-2.5)(.07985625)}{5-1} = .07880156$$

$$\text{Interference} = P_{5,5}(2.5) = \frac{(5-2.5)(.0777914) - (0-2.5)(.07880156)}{5-0} = .0783$$

or Percent Interference = 7.83%

Thus, the fifth order interpolation does not significantly improve on the third order result for this example.

#### A-2.1.3 Example Problem for Two-Way and Three-Way Interpolation

##### Two-Way Interpolation:

The preceding example demonstrates one-way higher order interpolation. The method can be easily extended to the problem of two-way and three-way interpolation where values of 2 or 3 different interference parameters are not in the tables. [For example,  $\alpha$  and  $\gamma$  or C,A, and B(x)]

For two-way interpolation of order  $n$ , the value of interference corresponding to interference parameters  $X = X^*$  and  $Y = Y^*$  (as shown in Table A-2.4) is determined as follows:

(1) Determine the interference values  $I_0^*, I_1^*, \dots, I_n^*$  for  $X = X_0, \dots, X_n$ , at  $Y = Y^*$  by performing the  $n+1$  one-way interpolations as discussed in Section A-2.1.2.

(2) Determine the value of interference,  $I^*$ , at  $X = X^*, Y = Y^*$  by performing the one-way interpolation on the interference values  $I_0^*, I_1^*, \dots, I_n^*$  obtained in (1).

The next section on three-way interpolation contains several examples of two-way interpolation.

##### Three-Way Interpolation:

The need for a three-way interpolation may arise when the fatigue strength is Weibull distributed and the stress is Normal distributed. If the

Y - Interference Parameter

$X_j$	$Y_0$	$Y_1$	$(Y_j^*)$	$Y_2$	$Y_3$	...	$Y_n$
$X_0$	$I_{0,0}$	$I_{0,1}$	$I_0^*$	$I_{0,2}$	$I_{0,3}$	...	$I_{0,n}$
$X_1$	$I_{1,0}$	$I_1^*$					
$(X^*) \rightarrow$	...	...	$(I^*)$				
$X_2$	$I_{2,0}$	$I_2^*$					
$X_3$	.	.					
.	.	.					
.	.	.					
$X_n$	$I_{n,0}$	$I_n^*$					$I_{n,n}$

$I_{ij}$  = Interference Value  
for  $X = X_i$  and  
 $Y = Y_j$

Table A-2.4 Interference Table Illustrating a Two-Way Interpolation

interference parameters have values, say  $B(x) = b^*$ ,  $A = A^*$  and  $C = C^*$ , and none of these values are available in the tables, then a three-way interpolation is required to obtain the interference value.

(1) Determine the interference value  $I_0^{**}$  for  $A = A^*$ ,  $C = C^*$ , and for a given value of  $B(x) = b_0$  appearing in the tables by performing a two-way interpolation as discussed above. By repeating this for various values of  $B(x) = b_0, b_1, b_2, \dots, b_n$ , appearing in the tables,  $n+1$  interference values  $I_0^{**}, I_1^{**}, \dots, I_n^{**}$  will be generated as shown in Table A-2.5 (a) and (b).

(2) Determine the value of interference  $I^{**}$  at  $B(x) = b^*$ ,  $C = C^*$ ,  $A = A^*$  by performing the one-way interpolation on the interference values  $I_0^{**}, I_1^{**}, \dots, I_n^{**}$  obtained in (1) as shown in Table A-2.6.

As an example of three-way interpolation, consider the Example Problem No. 1, given in Section 9, page 140, where the interference parameters are  $b = 1.808$ ,  $C = 3.72$ ,  $A = .0875$ . None of these values appear exactly in the tables, so a three-way interpolation is required.

As it involves a great number of calculations for high order three-way interpolations, a second order interpolation will be performed to demonstrate the technique.

For the three-way second order interpolation the following interference values were selected from the Tables in Appendix 2, pages 388 through 392.

The first step is to perform a total of three "two-way" interpolations where each two-way interpolation requires four "one-way" interpolations. The necessary calculations are as follows.

(1) Two-way interpolation within Table A-2.7(a) for  $b = 1.0$ ,  $A = .0875$ ,  $C = 3.72$

(i) One-way interpolation for  $A = -.2$ ,  $b = 1.0$ ,  $C = 3.72$

	(interference values from tables)		
$X_k = C_k$	$P_{k,0}$	$P_{k,1}$	$P_{k,2}$
$X_0 = 3.00$	.1372		
$X_1 = 3.50$	.1210	.113872	
( $X = 3.72$ ) $X_2 = 4.00$	.1081	.115324	<u>.11491744</u>

		$B(x) = b_0 \dots \dots \dots$		$B(x) = b_n$	
		$(C^*)$	$C_1 \dots \dots C_n$	$(C^*)$	$C_1 \dots \dots C_n$
$A$	$C$	$A_0$	$A_1$	$A_0$	$A_1$
		$I_0^*$	$I_1^*$	$I_0^*$	$I_1^*$
		$(A^*) \dots \dots (I_0^{**})$	$(A^*) \dots \dots (I_n^{**})$	$(A^*) \dots \dots (I_n^{**})$	$(A^*) \dots \dots (I_n^{**})$
		$I_2$	$I_2$	$I_2^*$	$I_2^*$
		$\dots$	$\dots$	$\dots$	$\dots$
		$\dots$	$\dots$	$\dots$	$\dots$
		$I_n^*$	$I_n^*$	$I_n^*$	$I_n^*$

(a)

(b)

Table A-2.5 Interference Table Illustrating (n+1) Two-Way Interpolations for (n+1) Consecutive Values of B(x)

$B(x) \backslash I$	Interference Values When $A = A^*$ and $C = C^*$
$b_0$	$I_0^{**}$
$b_1$	$I_1^{**}$
$(b^*) \rightarrow$	$(I^{**})$
$b_2$	$I_2^{**}$
.	.
.	.
.	.
$b_n$	$I_n^{**}$

Table A-2.6 Determination of the Interference Value Corresponding to  $A = A^*$ ,  $C = C^*$ , and  $B(x) = b^*$  by One-Way Interpolation.

		<u>(a)</u>		
		3.00	3.50	4.00
b = 1.0	A \ C			
	-0.2	.1372	.1210	.1081
	0.0	.1095	.0963	.0860
	0.2	.0852	.0749	.0668

		<u>(b)</u>		
		3.00	3.50	4.00
b = 2.0	A \ C			
	-0.2	.0639	.0490	.0386
	0.0	.0477	.0364	.0286
	0.2	.0348	.0265	.0207

		<u>(c)</u>		
		3.00	4.00	5.00
b = 3.0	A \ C			
	-0.2	.0359	.0166	.0088
	0.0	.0254	.0116	.0062
	0.2	.0176	.0080	.0042

Table A-2.7 Values of Interference  
as Read from the Tables in Appendix 2

$$P_{k,d+1}(X) = \frac{(X_k - X) P_{k-1,d}(X) - (X_k - X_{k-d-1}) P_{k,d}(X)}{X_k - X_{k-d-1}}$$

$$P_{11}(3.72) = \frac{(3.5 - 3.72)(.1372) - (3.0 - 3.72)(.1210)}{3.5 - 3.0} = .113872$$

$$P_{21}(3.72) = \frac{(4.0 - 3.72)(.1210) - (3.5 - 3.72)(.1081)}{4.0 - 3.5} = .115324$$

$$P_{22}(3.72) = \frac{(4.0 - 3.72)(.113872) - (3.0 - 3.72)(.115324)}{4.0 - 3.0} = .11491744$$

In a similar manner the following results are obtained!

(ii) One-way interpolation for  $A = 0$ ,  $b = 1.0$   $C = 3.72$

$C_k$	$P_{k,0}$	$P_{k,1}$	$P_{k,2}$
3.00	.1095		
3.50	.0963	.090492	
(3.72)			
4.00	.0860	.091688	<u>.09135312</u>

(iii) One-way interpolation for  $A = .2$ ,  $b = 1.0$ ,  $C = 3.72$

$C_k$	$P_{k,0}$	$P_{k,1}$	$P_{k,2}$
3.00	.0850		
3.50	.0749	.070456	
(3.72)			
4.00	.0668	.071336	<u>.07108960</u>



- (iv) One-way interpolation on the values obtained in (i), (ii), and (iii), to obtain interference for  $A = .0875$ ,  $b = 1.0$ ,  $C = 3.72$

		values obtained in (i), (ii), and (iii)		
$A_k$	$P_{k,0}$	$P_{k,1}$	$P_{k,2}$	
	-0.2	.11491744		
	0.0	.09135312	.08104375	
(.0875)	0.2	.07108960	.08248783	<u>.082081676</u>

- (2) Two-way interpolation within Table A-2.7;  $A = .0875$ ,  $b = 2.0$ ,  $C = 3.72$

- (i) One-way interpolation for  $A = -.2$ ,  $b = 2.0$ ,  $C = 3.72$

$C_k$	$P_{k,0}$	$P_{k,1}$	$P_{k,2}$
	3.0	.0639	
	3.5	.0490	.042444
(3.72)	4.0	.0386	.042444
			<u>.042444</u>

- (ii) One-way interpolation for  $A = 0$ ,  $b = 2.0$ ,  $C = 3.72$

$C_k$	$P_{k,0}$	$P_{k,1}$	$P_{k,2}$
	3.0	.0477	
	3.5	.0364	.031428
(3.72)	4.0	.0286	.032968
			<u>.03253680</u>

- (iii) One-way interpolation for  $A = .2$ ,  $b = 2.0$ ,  $C = 3.72$

$C_k$	$P_{k,0}$	$P_{k,1}$	$P_{k,2}$
	3.0	.0348	
	3.5	.0265	.022848
(3.72)	4.0	.0207	.023948
			<u>.023640</u>

- (iv) One-way interpolation on the values obtained in (i), (ii), and (iii), to obtain the interference for  $A = .0875$ ,  $b = 2.0$ ,  $C = 3.72$ .

$A_k$	$P_{k,0}$	$P_{k,1}$	$P_{k,2}$
-0.2	.042444		
0.0	.0325368	.02820240	
(.0875)			
0.2	.023640	.02864445	<u>.028520123</u>

- (3) Two-way interpolation within Table A-2.7(c) for  $A = .0875$ ,  $b = 3.0$ ,  $C = 3.72$ .

- (i) One-way interpolation for  $A = -.2$ ,  $b = 3.0$ ,  $C = 3.72$

$C_k$	$P_{k,0}$	$P_{k,1}$	$P_{k,2}$
3.0	.0359		
(3.72)			
4.0	.0166	.022004	
5.0	.0088	.018784	<u>.02084480</u>

- (ii) One-way interpolation for  $A = 0$ ,  $b = 3.0$ ,  $C = 3.72$

$C_k$	$P_{k,0}$	$P_{k,1}$	$P_{k,2}$
3.0	.0254		
(3.72)			
4.0	.0116	.015464	
5.0	.0062	.013112	<u>.01461728</u>

- (iii) One-way interpolation for  $A = .2$ ,  $b = 3.0$ ,  $C = 3.72$

$C_k$	$P_{k,0}$	$P_{k,1}$	$P_{k,2}$
3.0	.0176		
(3.72)			
4.0	.0080	.010688	
5.0	.0042	.009064	<u>.01010336</u>

- (iv) One-way interpolation on the values obtained (i), (ii), and (iii) to obtain the interference for  $A = .0875$ ,  $b = 3.0$ ,  $C = 3.72$ .

$A_k$	$P_{k,0}$	$P_{k,1}$	$P_{k,2}$
-0.2	.0208448		
0.0	.01461728	.01189274	
(.0875)			
0.2	.01010336	.01264244	<u>.012431587</u>

In the second step, the final result is obtained by performing the one-way interpolation for  $b = 1.808$  on the interference values calculated in part (iv) of (1), (2), and (3) above.

$b_k$	$P_{k,0}$	$P_{k,1}$	$P_{k,2}$
(1.808)	1.0	.082081676	
	2.0	.028520123	.038803941
	3.0	.012431587	.031609122 <u>.035897 = .0359</u>

Thus the interference for  $b = 1.808$ ,  $A = .0875$ ,  $C = 3.72$  as obtained by a three-way second order interpolation is:

$$\text{Interference} = .0359 \quad \text{or,}$$

$$\text{Percent Interference} = 3.59\%$$

Interference obtained by the three-way linear interpolation (as shown in Example Problem No. 1 in Section 9, page 141) is:

$$\text{Percent Interference} = 3.98\%$$

Hence, a substantial improvement is provided by using the higher order interpolation.

A-2.2 STRESS DISTRIBUTION - NORMAL  
STRENGTH DISTRIBUTION - WEIBULL

A-2.2.1 Stress Standard Deviation = 0

## TABLES OF INTERFERENCE [F(X)]

Stress Distribution: Normal

Strength Distribution: Weibull

 $\mu = S_{equ}$  (Equivalent Stress) $X_0$  Depend on the material and the operating conditions $\sigma = 0$  $b$  $\theta$ 

Figure A-2.1 Interference with Standard Deviation of Stress Equal to Zero

Weibull density function is:

$$f(x) = \frac{b}{\theta - X_0} \left( \frac{x - X_0}{\theta - X_0} \right)^{b-1} e^{-\left( \frac{x - X_0}{\theta - X_0} \right)^b}$$

Cumulative distribution function,  $F(x) = \int_{X_0}^{\infty} f(x) dx$ 

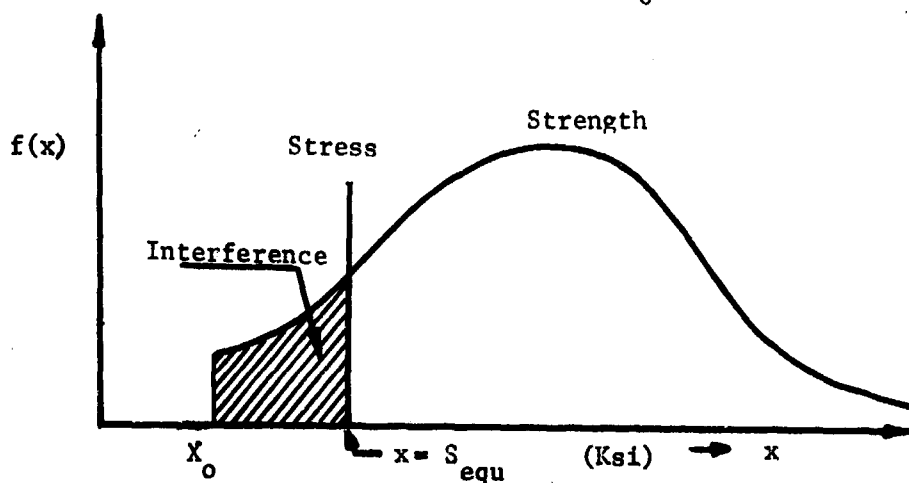
$$\text{Let } y = \left( \frac{x - X_0}{\theta - X_0} \right)^b, \quad \therefore dy = \frac{b}{\theta - X_0} \left( \frac{x - X_0}{\theta - X_0} \right)^{b-1} dx$$

$$F(x) = \int_{X_0}^{\infty} f(x) dx = \int_0^{\left( \frac{x - X_0}{\theta - X_0} \right)^b} e^{-y} dy = -e^{-y} \Big|_0^{\left( \frac{x - X_0}{\theta - X_0} \right)^b} = 1 - e^{-X}$$

$$\text{where } X = \left( \frac{x - X_0}{\theta - X_0} \right)^b = \left( \frac{S_{equ} - X_0}{\theta - X_0} \right)^b$$

## INTERFERENCE, F(X)

X	.000	.001	.002	.003	.004	.005	.006	.007	.008	.009
0.00	0	.001	.002	.003	.00399	.00498	.00598	.00697	.00796	.00896
0.01	.00995	.0109	.0119	.0129	.0139	.0149	.0158	.0168	.0178	.0188
0.02	.0198	.0208	.0217	.0227	.0237	.0246	.0256	.0266	.0276	.0286
0.03	.0295	.0304	.0314	.0324	.0334	.0344	.0353	.0363	.0372	.0382
0.04	.0392	.0401	.0411	.0420	.0430	.0440	.0449	.0458	.0468	.0477
0.05	.0487	.0496	.0506	.0515	.0525	.0535	.0544	.0553	.0562	.0572
0.06	.0581	.0591	.0600	.0610	.0619	.0628	.0637	.0646	.0656	.0665
0.07	.0675	.0685	.0694	.0703	.0712	.0721	.0730	.0740	.0749	.0759
0.08	.0768	.0776	.0786	.0795	.0805	.0814	.0823	.0832	.0841	.0850
0.09	.0860	.0869	.0878	.0887	.0896	.0905	.0914	.0923	.0932	.0941
X	.0	0.01	0.02	0.03	0.04	0.05	0.06	0.07	0.08	0.09
0.1	.0952	.1042	.1131	.1219	.1306	.1393	.1479	.1563	.1647	.1730
0.2	.1813	.1894	.1975	.2055	.2134	.2212	.2289	.2366	.2442	.2517
0.3	.2592	.2666	.2739	.2811	.2882	.2953	.3023	.3093	.3161	.3229
0.4	.3297	.3363	.3430	.3494	.3560	.3624	.3687	.3750	.3812	.3874
0.5	.3935	.3995	.4055	.4114	.4173	.4231	.4288	.4345	.4401	.4457
0.6	.4512	.4566	.4621	.4674	.4727	.4780	.4831	.4883	.4934	.4984
0.7	.5036	.5084	.5132	.5181	.5229	.5276	.5323	.5370	.5416	.5462
0.8	.5507	.5551	.5596	.5640	.5683	.5726	.5768	.5810	.5852	.5893
0.9	.5934	.5975	.6015	.6054	.6094	.6133	.6171	.6209	.6247	.6284

STRESS DISTRIBUTION - NORMAL ( $\sigma=0$ )  
STRENGTH DISTRIBUTION - WEIBULL

X	F(X)									
	0	0.10	0.20	0.30	0.40	0.50	0.60	0.70	0.80	0.90
	0.05	.15	0.25	0.35	0.45	0.55	0.65	0.75	0.85	0.95
1.0	.6321	.6671	.6988	.7275	.7534	.7769	.7981	.8173	.8347	.8504
	.6501	.6834	.7135	.7408	.7654	.7878	.8080	.8262	.8428	.8577
2.0	.8647	.8775	.8892	.8997	.9093	.9179	.9257	.9328	.9392	.9450
	.8713	.8835	.8946	.9046	.9137	.9219	.9293	.9361	.9422	.9477
3.0	.9502	.9550	.9592	.9631	.9666	.9698	.9727	.9753	.9776	.9798
	.9817	.9834	.9850	.9864	.9877	.9889	.9899	.9909	.9918	.9926
5.0	.99326	.99391	.99448	.99501	.99549	.99592	.99630	.99665	.99697	.99726
	.99752	.99776	.99797	.99816	.99836	.99850	.99864	.99877	.99889	.99899
7.0	.999088	.999175	.999253	.999324	.999389	.999447	.999499	.999547	.999590	.999629
	.999665	.999696	.999725	.999751	.999775	.999796	.999816	.999833	.999849	.999864
9.0	.999877	.999888	.999899	.999909	.999917	.999925	.999932	.999939	.999944	.999950

10.0 .999955

STRESS DISTRIBUTION - NORMAL ( $\sigma=0$ )

STRENGTH DISTRIBUTION - WEIBULL



A-2.2.2 Stress Standard Deviation  $\neq 0$

TABLES OF INTERFERENCE

Stress Distribution: Normal

Strength Distribution: Weibull

$\mu = S_{equ}$  (Equivalent Stress)

$X_0$  Depend on the material and the operating conditions

$\sigma \neq 0$

b or B(x)

$\theta$

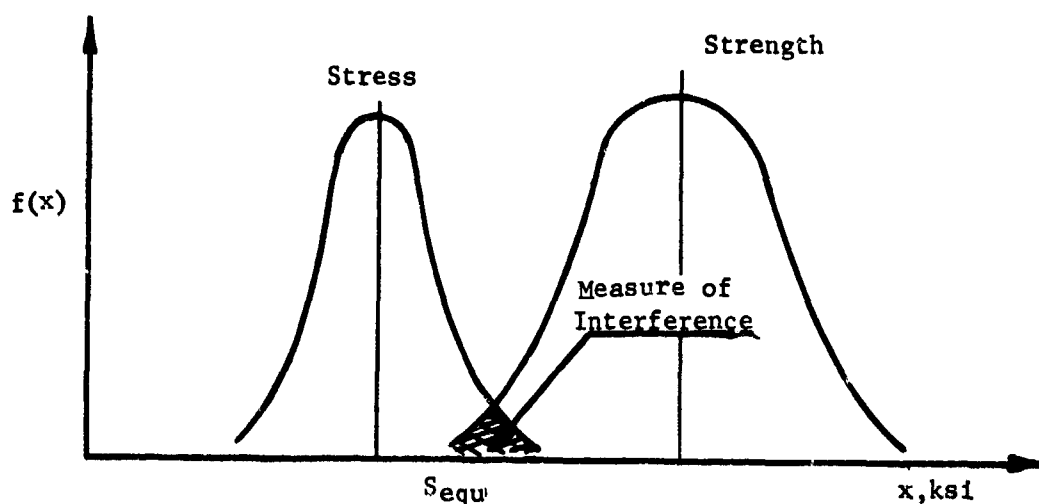

Figure A-22 Interference with Standard Deviation of Stress Not Equal to Zero

$B(x) = 1.00 - \frac{\theta - x}{\sigma} \cdot C$ ,  $A = \frac{x - \mu}{\sigma}$

A	1.00	1.50	2.00	2.50	3.00	3.50	4.00	4.50	5.00
1.0	.C567	.C424	.C238	.C281	.C241	.C21C	.C1E7	.C16E	.C153
1.2	.C290	.C290	.C221	.C191	.C164	.C143	.C127	.C114	.C103
1.4	.C259	.C192	.C152	.C126	.C1C8	.C154	.C183	.C175	.C168
1.6	.C167	.C123	.C097	.C081	.C069	.C06C	.C053	.C048	.C043
1.8	.C104	.C077	.C06C	.C05C	.C042	.C037	.C033	.C029	.C027
2.0	.C063	.C046	.C036	.C03C	.C025	.C022	.C020	.C018	.C016
2.2	.C037	.C027	.C021	.C017	.C015	.C013	.C011	.C01C	.C009
2.4	.C021	.C015	.C012	.C01C	.C0C8	.C0C7	.C006	.C006	.C005
2.6	.C011	.C008	.C0C6	.C0C5	.C0C4	.C0C4	.C0C3	.C0C3	.C0C3
2.8	.C0C6	.C0C4	.C0C5	.C0C3	.C0C2	.C0C2	.C0C2	.C0C2	.C0C1

$B(x) = 1.00 - \frac{\theta - x}{\sigma} \cdot C$ ,  $A = \frac{x - \mu}{\sigma}$

A	5.50	6.00	6.50	7.00	7.50	8.00	8.50	9.00	9.50
1.0	.C140	.C129	.C12C	.C112	.C1C5	.C099	.C093	.C08E	.C084
1.2	.C095	.C087	.C081	.C076	.C071	.C067	.C063	.C06C	.C057
1.4	.C062	.C057	.C053	.C05C	.C046	.C044	.C041	.C039	.C037
1.6	.C040	.C036	.C034	.C031	.C029	.C02E	.C026	.C025	.C024
1.8	.C024	.C022	.C021	.C019	.C018	.C017	.C016	.C015	.C014
2.0	.C015	.C013	.C012	.C012	.C011	.C01C	.C010	.C0C5	.C0C5
2.2	.C0C8	.C0C8	.C0C7	.C0C7	.C0C6	.C0C6	.C0C6	.C0C5	.C0C5
2.4	.C0C5	.C0C4	.C0C4	.C0C4	.C0C3	.C0C3	.C0C3	.C0C3	.C0C3
2.6	.C0C3	.C0C2	.C0C2	.C0C2	.C0C2	.C0C2	.C0C2	.C0C2	.C0C1
2.8	.C0C1	.C0C1	.C0C1	.C0C1	.C0C1	.C0C1	.C0C1	.C0C1	.C0C1

STRESS DISTRIBUTION - Normal  
STRENGTH DISTRIBUTION - Weibull

$B(x) = 1.10$   $C = \frac{\theta - x}{\sigma}, A = \frac{x - \mu}{\sigma}$

\* C

A	1.00	2.00	3.00	4.00	5.00	6.00	7.00	8.00	9.00
*	*****	*****	*****	*****	*****	*****	*****	*****	*****
1.0	.C545	.C305	.0212	.C16C	.0128	.01C6	.C090	.0C78	.0069
1.2	.C373	.C205	.0143	.C1C8	.0086	.0C71	.0061	.0053	.0047
1.4	.C247	.C137	.0C93	.CC7C	.0056	.0C46	.0C39	.0034	.0030
1.6	.0159	.CC87	.0C55	.CC44	.0035	.0C25	.0C25	.0022	.0019
1.8	.CC59	.CC54	.0C36	.CC27	.0C22	.0C18	.0015	.0C13	.0012
2.0	.CC59	.CC32	.0022	.CC16	.0C13	.0C11	.0009	.0008	.0007
2.2	.CC34	.CC15	.0012	.CC05	.0007	.0CC6	.0005	.0005	.0004
2.4	.CC19	.CC1C	.0007	.CC05	.0004	.0CC3	.0C03	.0C02	.0002
2.6	.CC10	.CC06	.0004	.CC03	.0002	.0CC2	.0002	.0001	.0001
2.8	.CC05	.CC03	.0002	.CC01	.0001	.0CC1	.0C01	.0C01	.0001

$B(x) = 1.20$   $C = \frac{\theta - x}{\sigma}, A = \frac{x - \mu}{\sigma}$

\* C

A	1.00	2.00	3.00	4.00	5.00	6.00	7.00	8.00	9.00
*	*****	*****	*****	*****	*****	*****	*****	*****	*****
1.0	.C525	.C2b3	.0187	.C137	.01C7	.0C87	.0C73	.0C63	.0055
1.2	.0358	.C190	.0125	.CC92	.0071	.0C58	.0C49	.0042	.0036
1.4	.0236	.C124	.0C81	.CC55	.0046	.0C38	.0C32	.0C27	.0024
1.6	.0151	.C075	.0051	.CC37	.0C25	.0C24	.0C20	.0017	.0015
1.8	.CC53	.CC48	.0031	.CC23	.0018	.0C14	.0012	.0010	.0009
2.0	.CC56	.CC25	.0C15	.CC12	.0C10	.0CC8	.0C07	.0006	.0005
2.2	.CC32	.CC16	.CC11	.CC08	.0006	.0CC5	.0C04	.0003	.0003
2.4	.CC18	.CC09	.0006	.CC04	.0C03	.0CC3	.0C02	.0002	.0002
2.6	.CC10	.CC05	.0003	.CC02	.0002	.0CC1	.0001	.0001	.0001
2.8	.CC05	.CC03	.0002	.CC01	.0001	.0CC1	.0001	.0001	.0000

STRESS DISTRIBUTION - Normal  
STRENGTH DISTRIBUTION - Weibull

**B(X) = 1.30**

$C = \frac{\theta - x_0}{\sigma}, A = \frac{x_0 - \mu}{\sigma}$

A	1.00	2.00	3.00	4.00	5.00	6.00	7.00	8.00	9.00
1.0	.0507	.0259	.0165	.0118	.0050	.0072	.0059	.0050	.0043
1.2	.0344	.0174	.0110	.0078	.0060	.0048	.0039	.0033	.0029
1.4	.0226	.0113	.0071	.0050	.0038	.0031	.0025	.0021	.0018
1.6	.0144	.0071	.0045	.0032	.0024	.0019	.0016	.0013	.0012
1.8	.0089	.0043	.0027	.0015	.0010	.0008	.0006	.0005	.0004
2.0	.0053	.0026	.0016	.0011	.0005	.0004	.0003	.0003	.0002
2.2	.0030	.0015	.0005	.0003	.0002	.0002	.0002	.0001	.0001
2.4	.0017	.0008	.0005	.0004	.0003	.0002	.0002	.0001	.0001
2.6	.0009	.0004	.0003	.0002	.0001	.0001	.0001	.0001	.0001
2.8	.0005	.0002	.0001	.0001	.0001	.0001	.0000	.0000	.0000

**B(X) = 1.40**

$C = \frac{\theta - x_0}{\sigma}, A = \frac{x_0 - \mu}{\sigma}$

A	1.00	2.00	3.00	4.00	5.00	6.00	7.00	8.00	9.00
1.0	.0491	.0239	.0147	.0102	.0076	.0060	.0048	.0040	.0034
1.2	.0332	.0159	.0097	.0067	.0050	.0039	.0032	.0027	.0023
1.4	.0217	.0103	.0062	.0043	.0032	.0025	.0020	.0017	.0014
1.6	.0138	.0064	.0039	.0027	.0020	.0016	.0013	.0011	.0009
1.8	.0084	.0039	.0023	.0016	.0012	.0009	.0008	.0006	.0005
2.0	.0050	.0023	.0014	.0005	.0007	.0005	.0004	.0004	.0003
2.2	.0029	.0013	.0008	.0005	.0004	.0003	.0002	.0002	.0002
2.4	.0016	.0007	.0004	.0003	.0002	.0002	.0001	.0001	.0001
2.6	.0009	.0004	.0002	.0002	.0001	.0001	.0001	.0001	.0001
2.8	.0004	.0002	.0001	.0001	.0001	.0001	.0000	.0000	.0000

STRESS DISTRIBUTION - Normal  
STRENGTH DISTRIBUTION - Weibull

**B(X) = 1.50**

\* C

A	1.00	2.00	3.00	4.00	5.00	6.00	7.00	8.00	9.00
1.0	.0476	.0221	.0131	.0088	.0064	.0045	.0040	.0033	.0027
1.2	.0321	.0146	.0086	.0058	.0042	.0032	.0026	.0021	.0018
1.4	.0209	.0094	.0055	.0037	.0027	.0021	.0016	.0014	.0011
1.6	.0132	.0058	.0034	.0023	.0017	.0013	.0010	.0008	.0007
1.8	.0081	.0035	.0020	.0014	.0010	.0008	.0006	.0005	.0004
2.0	.0048	.0021	.0012	.0008	.0006	.0004	.0004	.0003	.0002
2.2	.0027	.0012	.0007	.0004	.0003	.0002	.0002	.0002	.0001
2.4	.0015	.0006	.0004	.0002	.0002	.0001	.0001	.0001	.0001
2.6	.0008	.0003	.0002	.0001	.0001	.0001	.0001	.0000	.0000
2.8	.0004	.0002	.0001	.0001	.0000	.0000	.0000	.0000	.0000

**B(X) = 1.60**

\* C

A	1.00	2.00	3.00	4.00	5.00	6.00	7.00	8.00	9.00
1.0	.0463	.0205	.0117	.0076	.0055	.0041	.0032	.0026	.0022
1.2	.0310	.0135	.0076	.0050	.0035	.0027	.0021	.0017	.0014
1.4	.0202	.0096	.0048	.0032	.0022	.0017	.0013	.0011	.0005
1.6	.0127	.0052	.0030	.0019	.0014	.0010	.0008	.0007	.0006
1.8	.0077	.0032	.0018	.0012	.0008	.0006	.0005	.0004	.0003
2.0	.0045	.0019	.0010	.0007	.0005	.0004	.0003	.0002	.0002
2.2	.0026	.0010	.0006	.0004	.0003	.0002	.0002	.0001	.0001
2.4	.0014	.0006	.0003	.0002	.0001	.0001	.0001	.0001	.0001
2.6	.0008	.0003	.0002	.0001	.0001	.0001	.0000	.0000	.0000
2.8	.0004	.0002	.0001	.0001	.0000	.0000	.0000	.0000	.0000

STRESS DISTRIBUTION - Normal  
STRENGTH DISTRIBUTION - Weibull

**B(X) = 1.70**

$C = \frac{\theta - x_0}{\sigma}, A = \frac{x_0 - \mu}{\sigma}$

A	1.00	2.00	3.00	4.00	5.00	6.00	7.00	8.00	9.00
* * *									
*									
*	.0451	.0190	.0104	.0067	.0046	.0034	.0027	.0021	.0018
*	.0301	.0125	.0068	.0043	.0030	.0022	.0017	.0014	.0011
*	.0195	.0075	.0043	.0027	.0019	.0014	.0011	.0009	.0007
*	.0122	.0049	.0026	.0017	.0012	.0009	.0007	.0005	.0004
*	.0074	.0029	.0016	.0010	.0007	.0005	.0004	.0003	.0003
*	.0044	.0017	.0009	.0006	.0004	.0003	.0002	.0002	.0001
*	.0025	.0009	.0005	.0003	.0002	.0002	.0001	.0001	.0001
*	.0014	.0005	.0003	.0002	.0001	.0001	.0001	.0001	.0000
*	.0007	.0003	.0001	.0001	.0001	.0000	.0000	.0000	.0000
*	.0004	.0001	.0001	.0000	.0000	.0000	.0000	.0000	.0000

**B(X) = 1.80**

$C = \frac{\theta - x_0}{\sigma}, A = \frac{x_0 - \mu}{\sigma}$

A	1.00	2.00	3.00	4.00	5.00	6.00	7.00	8.00	9.00
* * *									
*									
*	.0440	.0177	.0094	.0058	.0040	.0029	.0022	.0017	.0014
*	.0293	.0115	.0061	.0037	.0025	.0019	.0014	.0011	.0009
*	.0185	.0073	.0038	.0023	.0016	.0012	.0009	.0007	.0006
*	.0114	.0045	.0023	.0014	.0010	.0007	.0005	.0004	.0003
*	.0071	.0027	.0014	.0008	.0006	.0004	.0003	.0002	.0002
*	.0042	.0015	.0008	.0005	.0003	.0002	.0002	.0001	.0001
*	.0024	.0009	.0004	.0003	.0002	.0001	.0001	.0001	.0001
*	.0013	.0005	.0002	.0001	.0001	.0001	.0001	.0000	.0000
*	.0007	.0002	.0001	.0001	.0000	.0000	.0000	.0000	.0000
*	.0003	.0001	.0001	.0000	.0000	.0000	.0000	.0000	.0000

STRESS DISTRIBUTION - Normal  
STRENGTH DISTRIBUTION - Weibull

$B(X) = 1.90$   
 $C = \frac{\theta - x_0}{\sigma}, A = \frac{x_0 - \mu}{\sigma}$

A	1.00	2.00	3.00	4.00	5.00	6.00	7.00	8.00	9.00
1.0	.0420	.0166	.0084	.0051	.0034	.0024	.0018	.0014	.0011
1.2	.0285	.0107	.0054	.0033	.0022	.0015	.0012	.0009	.0007
1.4	.0183	.0067	.0034	.0020	.0013	.0009	.0007	.0006	.0005
1.6	.0114	.0041	.0021	.0012	.0008	.0006	.0004	.0003	.0003
1.8	.0069	.0024	.0012	.0007	.0005	.0003	.0003	.0002	.0002
2.0	.0040	.0014	.0007	.0004	.0003	.0002	.0001	.0001	.0001
2.2	.0023	.0008	.0004	.0002	.0001	.0001	.0001	.0001	.0000
2.4	.0012	.0004	.0002	.0001	.0001	.0001	.0000	.0000	.0000
2.6	.0006	.0002	.0001	.0001	.0000	.0000	.0000	.0000	.0000
2.8	.0003	.0001	.0001	.0000	.0000	.0000	.0000	.0000	.0000

$B(X) = 2.00$   
 $C = \frac{\theta - x_0}{\sigma}, A = \frac{x_0 - \mu}{\sigma}$

A	1.00	1.50	2.00	2.50	3.00	3.50	4.00	4.50	5.00
1.0	.0421	.0244	.0155	.0106	.0076	.0057	.0045	.0036	.0029
1.2	.0278	.0159	.0100	.0068	.0049	.0037	.0028	.0023	.0019
1.4	.0178	.0100	.0063	.0042	.0030	.0023	.0018	.0014	.0011
1.6	.0111	.0061	.0038	.0026	.0018	.0014	.0011	.0008	.0007
1.8	.0066	.0036	.0022	.0015	.0011	.0008	.0006	.0005	.0004
2.0	.0039	.0021	.0013	.0008	.0006	.0005	.0003	.0003	.0002
2.2	.0022	.0012	.0007	.0005	.0003	.0002	.0002	.0002	.0001
2.4	.0012	.0006	.0004	.0002	.0002	.0001	.0001	.0001	.0001
2.6	.0006	.0003	.0002	.0001	.0001	.0001	.0001	.0000	.0000
2.8	.0003	.0002	.0001	.0001	.0000	.0000	.0000	.0000	.0000

STRESS DISTRIBUTION - Normal  
 STRENGTH DISTRIBUTION - Weibull



B(X) = 2.00

A	5.50	6.00	6.50	7.00	7.50	8.00	8.50	9.00	9.50
1.0	.0024	.0020	.0017	.0015	.0013	.0012	.0010	.0009	.0008
1.2	.0015	.0013	.0011	.0010	.0008	.0007	.0007	.0006	.0005
1.4	.0010	.0009	.0007	.0006	.0005	.0005	.0004	.0004	.0003
1.6	.0006	.0005	.0004	.0004	.0003	.0003	.0002	.0002	.0002
1.8	.0003	.0003	.0002	.0002	.0002	.0002	.0001	.0001	.0001
2.0	.0002	.0002	.0001	.0001	.0001	.0001	.0001	.0001	.0001
2.2	.0001	.0001	.0001	.0001	.0001	.0000	.0000	.0000	.0000
2.4	.0001	.0000	.0000	.0000	.0000	.0000	.0000	.0000	.0000
2.6	.0000	.0000	.0000	.0000	.0000	.0000	.0000	.0000	.0000
2.8	.0000	.0000	.0000	.0000	.0000	.0000	.0000	.0000	.0000

$$C = \frac{\theta - x_0}{\sigma}, \quad A = \frac{x_0 - \mu}{\sigma}$$

B(X) = 2.10

A	1.00	2.00	3.00	4.00	5.00	6.00	7.00	8.00	9.00
1.0	.0412	.0146	.0065	.0029	.0025	.0017	.0013	.0010	.0007
1.2	.0272	.0093	.0044	.0025	.0016	.0011	.0008	.0006	.0005
1.4	.0174	.0058	.0027	.0015	.0010	.0007	.0005	.0004	.0003
1.6	.0107	.0035	.0016	.0009	.0006	.0004	.0003	.0002	.0002
1.8	.0064	.0021	.0009	.0005	.0003	.0002	.0002	.0001	.0001
2.0	.0037	.0012	.0005	.0003	.0002	.0001	.0001	.0001	.0001
2.2	.0021	.0006	.0003	.0002	.0001	.0001	.0001	.0000	.0000
2.4	.0011	.0003	.0002	.0001	.0001	.0000	.0000	.0000	.0000
2.6	.0005	.0002	.0001	.0000	.0000	.0000	.0000	.0000	.0000
2.8	.0003	.0001	.0000	.0000	.0000	.0000	.0000	.0000	.0000

$$C = \frac{\theta - x_0}{\sigma}, \quad A = \frac{x_0 - \mu}{\sigma}$$

STRESS DISTRIBUTION - Normal  
STRENGTH DISTRIBUTION - Weibull

$B(x) = 2.20$

$C = \frac{\theta - x_0}{\sigma}, A = \frac{x_0 - \mu}{\sigma}$

A	1.00	2.00	3.00	4.00	5.00	6.00	7.00	8.00	9.00
1.0	.0404	.0137	.0063	.0035	.0022	.0015	.0010	.0008	.0006
1.2	.0266	.0087	.0040	.0022	.0014	.0009	.0007	.0005	.0004
1.4	.0165	.0054	.0024	.0013	.0008	.0006	.0004	.0003	.0002
1.6	.0105	.0033	.0015	.0008	.0005	.0003	.0002	.0002	.0001
1.8	.0062	.0019	.0008	.0005	.0003	.0002	.0001	.0001	.0001
2.0	.0036	.0011	.0005	.0003	.0002	.0001	.0001	.0001	.0000
2.2	.0020	.0006	.0003	.0001	.0001	.0000	.0000	.0000	.0000
2.4	.0011	.0003	.0001	.0001	.0000	.0000	.0000	.0000	.0000
2.6	.0006	.0002	.0001	.0000	.0000	.0000	.0000	.0000	.0000
2.8	.0003	.0001	.0000	.0000	.0000	.0000	.0000	.0000	.0000

$B(x) = 2.30$

$C = \frac{\theta - x_0}{\sigma}, A = \frac{x_0 - \mu}{\sigma}$

A	1.00	2.00	3.00	4.00	5.00	6.00	7.00	8.00	9.00
1.0	.0357	.0129	.0057	.0031	.0019	.0012	.0009	.0006	.0005
1.2	.0260	.0082	.0036	.0019	.0012	.0008	.0005	.0004	.0003
1.4	.0165	.0051	.0022	.0012	.0007	.0005	.0003	.0002	.0002
1.6	.0102	.0030	.0013	.0007	.0004	.0003	.0002	.0001	.0001
1.8	.0061	.0018	.0007	.0004	.0002	.0002	.0001	.0001	.0001
2.0	.0035	.0010	.0004	.0002	.0001	.0001	.0001	.0000	.0000
2.2	.0019	.0005	.0002	.0001	.0001	.0000	.0000	.0000	.0000
2.4	.0010	.0003	.0001	.0001	.0000	.0000	.0000	.0000	.0000
2.6	.0005	.0001	.0001	.0000	.0000	.0000	.0000	.0000	.0000
2.8	.0003	.0001	.0000	.0000	.0000	.0000	.0000	.0000	.0000

STRESS DISTRIBUTION - Normal  
STRENGTH DISTRIBUTION - Weibull

**B(X) = 2.40**

$C = \frac{\theta - x_0}{\sigma}, A = \frac{x_0 - \mu}{\sigma}$

A	1.00	2.00	3.00	4.00	5.00	6.00	7.00	8.00	9.00
1.0	.C350	.C122	.0C52	.CC27	.0C16	.0C11	.CC07	.0CC5	.0004
1.2	.0255	.C077	.0033	.CC17	.0010	.0CC7	.0005	.0003	.0003
1.4	.C162	.C047	.0C20	.CC1C	.0006	.0CC4	.0003	.0002	.0002
1.6	.CC99	.C028	.0C12	.CC0E	.0004	.0CC2	.0002	.0001	.0001
1.8	.CC59	.CC16	.0007	.CC03	.0002	.0CC1	.0001	.0001	.0001
2.0	.CC34	.CC05	.0004	.CC02	.0001	.0CC1	.0001	.0000	.0000
2.2	.CC19	.CC05	.0002	.CC01	.0001	.0CC0	.0000	.0000	.0000
2.4	.CC10	.CC03	.0001	.CC01	.0000	.0CC0	.0000	.0000	.0000
2.6	.CC05	.CC01	.0001	.CC00	.0000	.0CC0	.0000	.0000	.0000
2.8	.CC03	.CC01	.0000	.CC00	.0000	.0CC0	.0000	.0000	.0000

**B(X) = 2.50**

$C = \frac{\theta - x_0}{\sigma}, A = \frac{x_0 - \mu}{\sigma}$

A	1.00	2.00	3.00	4.00	5.00	6.00	7.00	8.00	9.00
1.0	.C283	.C116	.0C47	.CC24	.0C14	.0CC5	.0006	.0004	.0003
1.2	.0250	.CC73	.0C30	.CC15	.0009	.0CC6	.0004	.0003	.0002
1.4	.C158	.CC44	.0C18	.CC05	.0005	.0CC3	.0002	.0002	.0001
1.6	.CC97	.C02C	.001C	.CC0E	.0003	.0CC2	.0001	.0001	.0001
1.8	.CC57	.0015	.0006	.CC03	.0002	.0CC1	.0001	.0001	.0000
2.0	.CC33	.CC08	.0003	.CC02	.0001	.0CC1	.0000	.0000	.0000
2.2	.CC18	.CC05	.0002	.CC01	.0001	.0CC0	.0000	.0000	.0000
2.4	.CC10	.CC02	.0001	.CC00	.0000	.0CC0	.0000	.0000	.0000
2.6	.CC05	.CC01	.0000	.CC00	.0000	.0CC0	.0000	.0000	.0000
2.8	.CC03	.CC01	.0000	.CC00	.0000	.0CC0	.0000	.0000	.0000

STRESS DISTRIBUTION - Normal  
STRENGTH DISTRIBUTION - Weibull

**B(X) = 2.60**

$C = \frac{\theta - x_0}{\sigma}, A = \frac{x_0 - \mu}{\sigma}$

A	1.00	2.00	3.00	4.00	5.00	6.00	7.00	8.00	9.00
* * *	* * *	* * *	* * *	* * *	* * *	* * *	* * *	* * *	* * *
1.0	.C278	.C110	.C043	.CC21	.0C12	.0CC8	.CC05	.0CC4	.0003
1.2	.C245	.C069	.0027	.CC13	.0009	.0CC5	.0C03	.0CC2	.0002
1.4	.C155	.C042	.C016	.CC08	.0CC5	.0CC3	.0CC2	.0001	.0001
1.6	.C095	.C025	.0CC5	.CC05	.0CC3	.0CC2	.0001	.0001	.0001
1.8	.C056	.C014	.0CC5	.CC03	.0C01	.0CC1	.0001	.0000	.0000
2.0	.C032	.C008	.0CC3	.CC01	.0C01	.0CC1	.0000	.0000	.0000
2.2	.C018	.0004	.0CC2	.CC01	.0000	.0CC0	.0000	.0000	.0000
2.4	.C009	.0002	.0CC1	.CC00	.0000	.0CC0	.0000	.0000	.0000
2.6	.C005	.0001	.0CC0	.CC00	.0000	.0CC0	.0000	.0000	.0000
2.8	.C002	.0001	.0CC0	.CC00	.0000	.0CC0	.0000	.0000	.0000

**B(X) = 2.70**

$C = \frac{\theta - x_0}{\sigma}, A = \frac{x_0 - \mu}{\sigma}$

A	1.00	2.00	3.00	4.00	5.00	6.00	7.00	8.00	9.00
* * *	* * *	* * *	* * *	* * *	* * *	* * *	* * *	* * *	* * *
1.0	.C272	.C104	.0C4C	.CC19	.0C11	.0CC7	.0004	.0CC3	.0002
1.2	.C242	.C065	.0C25	.CC12	.0007	.0CC4	.0003	.0CC2	.0001
1.4	.C152	.C039	.0C15	.CC07	.0CC4	.0CC2	.0002	.0CC1	.0001
1.6	.C093	.C023	.0CC5	.CC04	.0C02	.0CC1	.0001	.0001	.0000
1.8	.C055	.C013	.0CC5	.CC02	.0C01	.0CC1	.0001	.0CC0	.0000
2.0	.C031	.C007	.0CC3	.CC01	.0001	.0CC0	.0000	.0CC0	.0000
2.2	.C017	.C004	.0CC1	.CC01	.0000	.0CC0	.0000	.0000	.0000
2.4	.C009	.C002	.0CC1	.CC00	.0000	.0CC0	.0000	.0000	.0000
2.6	.C005	.0001	.0CC0	.CC00	.0000	.0CC0	.0000	.0000	.0000
2.8	.C002	.0000	.0CC0	.CC00	.0000	.0CC0	.0000	.0000	.0000

STRESS DISTRIBUTION - Normal  
STRENGTH DISTRIBUTION - Weibull

$B(x) = 2.90$

$C = \frac{\theta - x_0}{\sigma}, A = \frac{x_0 - \mu}{\sigma}$

A	1.00	2.00	3.00	4.00	5.00	6.00	7.00	8.00	9.00
1.0	.0000	.0000	.0000	.0000	.0000	.0000	.0000	.0000	.0000
1.2	.0000	.0000	.0000	.0000	.0000	.0000	.0000	.0000	.0000
1.4	.0000	.0000	.0000	.0000	.0000	.0000	.0000	.0000	.0000
1.6	.0000	.0000	.0000	.0000	.0000	.0000	.0000	.0000	.0000
1.8	.0000	.0000	.0000	.0000	.0000	.0000	.0000	.0000	.0000
2.0	.0000	.0000	.0000	.0000	.0000	.0000	.0000	.0000	.0000
2.2	.0000	.0000	.0000	.0000	.0000	.0000	.0000	.0000	.0000
2.4	.0000	.0000	.0000	.0000	.0000	.0000	.0000	.0000	.0000
2.6	.0000	.0000	.0000	.0000	.0000	.0000	.0000	.0000	.0000
2.8	.0000	.0000	.0000	.0000	.0000	.0000	.0000	.0000	.0000

$B(x) = 2.90$

$C = \frac{\theta - x_0}{\sigma}, A = \frac{x_0 - \mu}{\sigma}$

A	1.00	2.00	3.00	4.00	5.00	6.00	7.00	8.00	9.00
1.0	.0000	.0000	.0000	.0000	.0000	.0000	.0000	.0000	.0000
1.2	.0000	.0000	.0000	.0000	.0000	.0000	.0000	.0000	.0000
1.4	.0000	.0000	.0000	.0000	.0000	.0000	.0000	.0000	.0000
1.6	.0000	.0000	.0000	.0000	.0000	.0000	.0000	.0000	.0000
1.8	.0000	.0000	.0000	.0000	.0000	.0000	.0000	.0000	.0000
2.0	.0000	.0000	.0000	.0000	.0000	.0000	.0000	.0000	.0000
2.2	.0000	.0000	.0000	.0000	.0000	.0000	.0000	.0000	.0000
2.4	.0000	.0000	.0000	.0000	.0000	.0000	.0000	.0000	.0000
2.6	.0000	.0000	.0000	.0000	.0000	.0000	.0000	.0000	.0000
2.8	.0000	.0000	.0000	.0000	.0000	.0000	.0000	.0000	.0000

STRESS DISTRIBUTION - Normal  
STRENGTH DISTRIBUTION - Weibull

$B(X) = 3.00$

$C = \frac{\theta - x_0}{\sigma}, A = \frac{x_0 - \mu}{\sigma}$

A	*	1.00	2.00	3.00	4.00	5.00	6.00	7.00	8.00	9.00
1.0	*	.C357	.CC90	.CC21	.CC14	.CC07	.CCC4	.C003	.CCC2	.0001
1.2	*	.C231	.C056	.C019	.CCC8	.C004	.CCC3	.C002	.C001	.0001
1.4	*	.C145	.CC33	.C011	.CCC5	.C003	.CC61	.C001	.C001	.0000
1.6	*	.CC88	.C019	.C0C6	.CCC3	.C0C1	.CCC1	.C001	.C000	.0000
1.8	*	.CC51	.C011	.C0C4	.CCC2	.C001	.CCC0	.C000	.C000	.0000
2.0	*	.CC29	.CCC6	.C0C2	.CCC1	.C000	.CCC0	.C000	.C000	.0000
2.2	*	.CC16	.CC03	.C0C1	.CCC0	.C000	.CCC0	.C000	.C000	.0000
2.4	*	.CC08	.CC02	.C0C1	.CCC0	.C000	.CCC0	.C000	.C000	.0000
2.6	*	.CC04	.CC01	.C0C0	.CCC0	.C000	.CCC0	.C000	.C000	.0000
2.8	*	.CC02	.CC00	.C0C0	.CCC0	.C000	.CCC0	.C000	.C000	.0000

$B(X) = 3.10$

$C = \frac{\theta - x_0}{\sigma}, A = \frac{x_0 - \mu}{\sigma}$

A	*	1.00	2.00	3.00	4.00	5.00	6.00	7.00	8.00	9.00
1.0	*	.C353	.CC86	.CC25	.CC12	.CC06	.CCC4	.CC02	.CCC1	.0001
1.2	*	.C228	.CC53	.CC17	.CCC7	.CC04	.CCC2	.C001	.CCC1	.0001
1.4	*	.C142	.CC32	.CC10	.CCC4	.C002	.CCC1	.C001	.C001	.0000
1.6	*	.CC86	.CC18	.CC06	.CCC2	.C001	.CCC1	.C000	.C000	.0000
1.8	*	.CC50	.CC10	.CC03	.CCC1	.C001	.CCC0	.C000	.C000	.0000
2.0	*	.CC28	.CC06	.CC02	.CCC1	.C000	.CCC0	.C000	.C000	.0000
2.2	*	.CC16	.C003	.CC01	.CCC0	.C000	.CCC0	.C000	.C000	.0000
2.4	*	.CC08	.CC01	.C0C0	.CCC0	.C000	.CCC0	.C000	.C000	.0000
2.6	*	.CC04	.CC01	.C0C0	.CCC0	.C000	.CCC0	.C000	.C000	.0000
2.8	*	.CC02	.CC00	.C0C0	.CCC0	.C000	.CCC0	.C000	.C000	.0000

STRESS DISTRIBUTION - Normal  
STRENGTH DISTRIBUTION - Weibull

B(X) = 3.20

		$C = \frac{\theta - x_0}{\sigma}, A = \frac{x - \mu}{\sigma}$								
A	*	1.00	2.00	3.00	4.00	5.00	6.00	7.00	8.00	9.00
1.0	*	.C249	.CC83	.0C27	.CC11	.0006	.0CC2	.0002	.CC01	.0001
1.2	*	.0225	.CC51	.0016	.CC07	.0003	.0CC2	.0001	.0001	.0001
1.4	*	.0140	.CC30	.0CC9	.CC04	.0CC2	.0CC1	.0001	.0000	.0000
1.6	*	.CC85	.C017	.0CC5	.CC02	.0C01	.0CC1	.0000	.0000	.0000
1.8	*	.CC49	.C010	.0CC3	.CC01	.0001	.0C0C	.0000	.000C	.0000
2.0	*	.CC28	.CC05	.0CC2	.CC01	.0000	.0C0C	.0000	.000C	.0000
2.2	*	.CC15	.0C03	.0001	.CC0C	.0000	.0CC0	.0000	.0000	.0000
2.4	*	.CC08	.CC01	.0000	.CC0C	.0000	.0CC0	.0000	.0000	.0000
2.6	*	.CC04	.C001	.0000	.CC0C	.0000	.0CC0	.0000	.0000	.0000
2.8	*	.CC02	.CC0C	.0000	.CC0C	.0000	.0CC0	.0000	.0000	.0000

STRESS DISTRIBUTION - Normal  
STRENGTH DISTRIBUTION - Weibull

$B(X) = 1.00$

$C = \frac{\theta - x_0}{\sigma}, A = \frac{x_0 - \mu}{\sigma}$

A	*	1.00	1.50	2.00	2.50	3.00	3.50	4.00	4.50	5.00
* .8	*	.0800	.0602	.0482	.0402	.0344	.0301	.0268	.0241	.0219
* .6	*	.1096	.0830	.0667	.0558	.0479	.0419	.0373	.0336	.0306
* .4	*	.1459	.1113	.0898	.0753	.0647	.0568	.0506	.0456	.0415
* .2	*	.1890	.1452	.1177	.0989	.0852	.0749	.0668	.0602	.0549
* .0	*	.2384	.1847	.1504	.1267	.1095	.0963	.0860	.0776	.0708
* -.2	*	.2933	.2291	.1875	.1585	.1372	.1210	.1081	.0977	.0892
* -.4	*	.3523	.2777	.2285	.1939	.1682	.1486	.1330	.1203	.1099
* -.6	*	.4140	.3294	.2726	.2321	.2020	.1787	.1602	.1452	.1327
* -.8	*	.4765	.3830	.3188	.2726	.2379	.2109	.1894	.1718	.1572
* -1.0	*	.5381	.4370	.3661	.3143	.2751	.2445	.2199	.1998	.1830
* -1.4	*	.6528	.5419	.4601	.3986	.3512	.3136	.2831	.2580	.2369
* -1.8	*	.7493	.6363	.5480	.4794	.4252	.3817	.3460	.3164	.2913
* -2.2	*	.8244	.7160	.6257	.5529	.4941	.4460	.4061	.3725	.3440
* -2.6	*	.8796	.7805	.6920	.6178	.5562	.5049	.4618	.4252	.3938
* -3.0	*	.9184	.8313	.7474	.6739	.6112	.5581	.5127	.4738	.4402
* -3.4	*	.9451	.8706	.7930	.7220	.6597	.6057	.5590	.5185	.4832
* -3.8	*	.9631	.9009	.8305	.7631	.7021	.6483	.6010	.5595	.5229
* -4.2	*	.9753	.9241	.8612	.7981	.7393	.6863	.6390	.5969	.5596
* -4.6	*	.9834	.9418	.8864	.8280	.7719	.7201	.6733	.6312	.5934
* -5.0	*	.9889	.9554	.9070	.8534	.8003	.7504	.7044	.6626	.6247
* -5.5	*	.9933	.9681	.9276	.8800	.8310	.7836	.7391	.6981	.6604
* -6.0	*	.9959	.9771	.9436	.9017	.8569	.8124	.7698	.7298	.6927
* -6.5	*	.9975	.9836	.9561	.9195	.8789	.8374	.7968	.7582	.7220
* -7.0	*	.9985	.9883	.9658	.9341	.8975	.8590	.8207	.7837	.7484
* -8.0	*	.9994	.9940	.9792	.9558	.9265	.8941	.8604	.8268	.7940
* -9.0	*	.9998	.9969	.9874	.9704	.9474	.9204	.8913	.8613	.8314
* -10.0	*	.9999	.9984	.9924	.9802	.9623	.9402	.9153	.8889	.8619

STRESS DISTRIBUTION - Normal  
STRENGTH DISTRIBUTION - Weibull



B(X) = 1.00

$$C = \frac{\theta - x_0}{\sigma}, \quad A = \frac{x_0 - \mu}{\sigma}$$

\* \* \* C

A	* 5.50	* 6.00	* 6.50	* 7.00	* 7.50	* 8.00	* 8.50	* 9.00	* 9.50
* .8	.0201	.0185	.0172	.0161	.0151	.0142	.0134	.0127	.0120
* .6	.0280	.0259	.0240	.0224	.0210	.0198	.0187	.0177	.0168
* .4	.0381	.0352	.0327	.0305	.0286	.0269	.0255	.0241	.0229
* .2	.0504	.0465	.0433	.0404	.0379	.0357	.0338	.0320	.0304
* .0	.0650	.0601	.0559	.0523	.0490	.0462	.0437	.0414	.0394
* -.2	.0820	.0758	.0706	.0660	.0620	.0584	.0552	.0524	.0498
* -.4	.1011	.0936	.0872	.0815	.0766	.0722	.0683	.0648	.0616
* -.6	.1222	.1132	.1055	.0987	.0928	.0875	.0828	.0786	.0748
* -.8	.1449	.1344	.1252	.1173	.1103	.1040	.0985	.0935	.0890
* -1.0	.1688	.1567	.1462	.1369	.1288	.1216	.1152	.1094	.1041
* -1.4	.2190	.2036	.1902	.1784	.1680	.1588	.1505	.1430	.1363
* -1.8	.2699	.2514	.2352	.2210	.2083	.1971	.1870	.1779	.1696
* -2.2	.3195	.2981	.2794	.2629	.2482	.2351	.2233	.2126	.2028
* -2.6	.3666	.3428	.3219	.3034	.2868	.2720	.2586	.2464	.2354
* -3.0	.4108	.3851	.3622	.3419	.3237	.3074	.2925	.2791	.2668
* -3.4	.4521	.4247	.4003	.3784	.3588	.3411	.3250	.3104	.2970
* -3.8	.4905	.4618	.4360	.4130	.3921	.3732	.3561	.3404	.3260
* -4.2	.5263	.4965	.4697	.4456	.4237	.4038	.3857	.3690	.3537
* -4.6	.5595	.5289	.5014	.4764	.4536	.4329	.4139	.3965	.3804
* -5.0	.5904	.5593	.5311	.5054	.4820	.4605	.4408	.4227	.4059
* -5.5	.6260	.5946	.5658	.5395	.5154	.4932	.4728	.4539	.4364
* -6.0	.6585	.6270	.5980	.5713	.5467	.5239	.5029	.4834	.4653
* -6.5	.6882	.6568	.6277	.6008	.5759	.5528	.5313	.5113	.4927
* -7.0	.7153	.6842	.6553	.6283	.6032	.5799	.5581	.5377	.5187
* -8.0	.7626	.7327	.7045	.6778	.6528	.6292	.6071	.5863	.5668
* -9.0	.8021	.7737	.7466	.7207	.6961	.6728	.6507	.6298	.6101
* -10.0	.8350	.8085	.7827	.7579	.7340	.7112	.6895	.6688	.6490

STRESS DISTRIBUTION - Normal  
STRENGTH DISTRIBUTION - Weibull

$$C = \frac{\theta - x_0}{\sigma}, \quad A = \frac{x_0 - \mu}{\sigma}$$

$\theta(x) = 2.00$

\* \* \* C

A	1.00	1.50	2.00	2.50	3.00	3.50	4.00	4.50	5.00
* .8	.0616	.0364	.0234	.0160	.0116	.0087	.0068	.0054	.0045
* .6	.0876	.0528	.0343	.0237	.0172	.0130	.0101	.0081	.0066
* .4	.1209	.0744	.0488	.0340	.0248	.0188	.0147	.0118	.0096
* .2	.1621	.1020	.0678	.0475	.0348	.0265	.0207	.0166	.0136
* .0	.2113	.1362	.0918	.0648	.0477	.0364	.0286	.0230	.0189
* -.2	.2682	.1772	.1211	.0863	.0639	.0450	.0386	.0311	.0255
* -.4	.3318	.2248	.1561	.1124	.0838	.0644	.0509	.0411	.0338
* -.6	.4003	.2787	.1968	.1421	.1074	.0830	.0657	.0532	.0439
* -.8	.4719	.3377	.2427	.1785	.1350	.1048	.0833	.0676	.0558
* -1.0	.5443	.4005	.2933	.2184	.1664	.1299	.1037	.0844	.0698
* -1.4	.6818	.5312	.4048	.3094	.2401	.1897	.1527	.1250	.1040
* -1.8	.7973	.6569	.5220	.4108	.3252	.2606	.2119	.1748	.1462
* -2.2	.8828	.7659	.6349	.5154	.4171	.3356	.2793	.2324	.1955
* -2.6	.9387	.8514	.7352	.6163	.5107	.4230	.3523	.2959	.2508
* -3.0	.9711	.9124	.8178	.7076	.6009	.5070	.4281	.3634	.3105
* -3.4	.9877	.9521	.8811	.7856	.6838	.5880	.5040	.4326	.3729
* -3.8	.9953	.9757	.9264	.8488	.7566	.6634	.5773	.5015	.4363
* -4.2	.9984	.9885	.9568	.8574	.8180	.7311	.6462	.5682	.4993
* -4.6	.9995	.9950	.9760	.9330	.8679	.7900	.7090	.6314	.5605
* -5.0	.9999	.9980	.9873	.9580	.9068	.8396	.7649	.6898	.6188
* -5.5	1.0000	.9994	.9947	.9778	.9422	.8850	.8244	.7550	.6862
* -6.0	1.0000	.9998	.9980	.9889	.9657	.9259	.8724	.8108	.7464
* -6.5	1.0000	1.0000	.9993	.9948	.9806	.9522	.9098	.8572	.7988
* -7.0	1.0000	1.0000	.9998	.9977	.9895	.9702	.9380	.8945	.8433
* -8.0	1.0000	1.0000	1.0000	.9996	.9973	.9856	.9731	.9463	.9101
* -9.0	1.0000	1.0000	1.0000	1.0000	.9994	.9968	.9895	.9750	.9521
* -10.0	1.0000	1.0000	1.0000	1.0000	.9999	.9992	.9964	.9893	.9763

STRESS DISTRIBUTION - Normal  
STRENGTH DISTRIBUTION - Weibull

$$C = \frac{\theta - x_0}{\sigma}, \quad A = \frac{x_0 - \mu}{\sigma}$$

B(x) = 2.00

A	5.50	6.00	6.50	7.00	7.50	8.00	8.50	9.00	9.50
* .8	.0037	.0031	.0027	.0023	.0020	.0018	.0016	.0014	.0013
* .6	.0055	.0047	.0040	.0035	.0030	.0027	.0024	.0021	.0019
* .4	.0080	.0068	.0058	.0050	.0044	.0039	.0034	.0031	.0028
* .2	.0114	.0096	.0082	.0071	.0062	.0055	.0049	.0044	.0039
* .0	.0158	.0133	.0114	.0099	.0087	.0076	.0068	.0061	.0054
* -.2	.0213	.0181	.0155	.0134	.0118	.0104	.0092	.0082	.0074
* -.4	.0283	.0240	.0206	.0178	.0156	.0138	.0122	.0110	.0099
* -.6	.0367	.0312	.0268	.0232	.0204	.0180	.0160	.0143	.0129
* -.8	.0468	.0398	.0342	.0297	.0260	.0230	.0204	.0183	.0165
* -1.0	.0587	.0499	.0429	.0373	.0327	.0289	.0257	.0230	.0207
* -1.4	.0877	.0748	.0645	.0562	.0493	.0436	.0389	.0348	.0314
* -1.8	.1237	.1059	.0916	.0799	.0703	.0623	.0555	.0498	.0449
* -2.2	.1664	.1430	.1240	.1085	.0956	.0848	.0758	.0680	.0614
* -2.6	.2146	.1853	.1613	.1415	.1250	.1111	.0994	.0894	.0808
* -3.0	.2673	.2319	.2027	.1784	.1580	.1408	.1262	.1136	.1028
* -3.4	.3233	.2820	.2475	.2186	.1942	.1735	.1558	.1406	.1274
* -3.8	.3811	.3344	.2949	.2615	.2331	.2088	.1879	.1695	.1542
* -4.2	.4395	.3881	.3441	.3064	.2741	.2462	.2222	.2013	.1831
* -4.6	.4975	.4423	.3943	.3527	.3166	.2854	.2582	.2344	.2136
* -5.0	.5539	.4959	.4446	.3956	.3602	.3258	.2956	.2690	.2457
* -5.5	.6209	.5609	.5068	.4584	.4154	.3773	.3436	.3138	.2874
* -6.0	.6828	.6226	.5669	.5161	.4703	.4293	.3926	.3598	.3305
* -6.5	.7387	.6798	.6239	.5719	.5242	.4808	.4416	.4062	.3743
* -7.0	.7880	.7319	.6771	.6250	.5763	.5313	.4901	.4526	.4185
* -8.0	.8669	.8194	.7659	.7205	.6725	.6266	.5834	.5431	.5058
* -9.0	.9214	.8845	.8433	.7958	.7554	.7114	.6685	.6277	.5889
* -10.0	.9564	.9300	.8980	.8620	.8235	.7836	.7435	.7039	.6655

STRESS DISTRIBUTION - Normal  
STRENGTH DISTRIBUTION - Weibull



$$C = \frac{\theta - x_0}{\sigma}, \quad A = \frac{x_0 - \mu}{\sigma}$$

B(X) = 4.00

\* \* \* C

A	* 1.00	* 2.00	* 3.00	* 4.00	* 5.00	* 6.00	* 7.00	* 8.00	* 9.00
* .8	.0491	.0100	.0026	.0009	.0004	.0002	.0001	.0001	.0000
* .6	.0722	.0159	.0042	.0014	.0006	.0003	.0002	.0001	.0001
* .4	.1028	.0245	.0066	.0023	.0010	.0005	.0003	.0001	.0001
* .2	.1418	.0366	.0103	.0036	.0015	.0007	.0004	.0002	.0001
* .0	.1899	.0534	.0156	.0055	.0023	.0011	.0006	.0004	.0002
* -.2	.2463	.0756	.0230	.0083	.0035	.0017	.0009	.0006	.0003
* -.4	.3117	.1043	.0332	.0121	.0052	.0026	.0014	.0008	.0005
* -.6	.3832	.1401	.0467	.0174	.0075	.0037	.0020	.0012	.0007
* -.8	.4588	.1835	.0644	.0245	.0107	.0053	.0029	.0017	.0011
* -1.0	.5360	.2344	.0868	.0338	.0149	.0074	.0040	.0024	.0015
* -1.4	.6837	.3562	.1480	.0609	.0275	.0138	.0076	.0045	.0028
* -1.8	.8067	.4948	.2328	.1022	.0474	.0241	.0133	.0079	.0050
* -2.2	.8950	.6343	.3394	.1605	.0772	.0399	.0222	.0132	.0083
* -2.6	.9497	.7581	.4609	.2369	.1189	.0627	.0353	.0211	.0133
* -3.0	.9788	.8549	.5865	.3299	.1742	.0941	.0536	.0323	.0205
* -3.4	.9922	.9216	.7042	.4351	.2432	.1354	.0784	.0476	.0303
* -3.8	.9975	.9620	.8039	.5456	.3248	.1874	.1105	.0679	.0435
* -4.2	.9993	.9836	.8803	.6532	.4161	.2500	.1508	.0937	.0605
* -4.6	.9998	.9937	.9331	.7502	.5127	.3223	.1995	.1259	.0819
* -5.0	1.0000	.9979	.9659	.8311	.6091	.4022	.2565	.1647	.1082
* -5.5	1.0000	.9995	.9872	.9059	.7212	.5084	.3383	.2227	.1487
* -6.0	1.0000	.9999	.9959	.9532	.8157	.6150	.4289	.2909	.1977
* -6.5	1.0000	1.0000	.9989	.9794	.8879	.7145	.5241	.3677	.2554
* -7.0	1.0000	1.0000	.9997	.9920	.9377	.8007	.6189	.4507	.3208
* -8.0	1.0000	1.0000	1.0000	.9992	.9857	.9209	.7869	.6217	.4688
* -9.0	1.0000	1.0000	1.0000	1.0000	.9979	.9769	.9037	.7746	.6237
* -10.0	1.0000	1.0000	1.0000	1.0000	.9993	.9953	.9660	.8870	.7637

STRESS DISTRIBUTION - Normal  
STRENGTH DISTRIBUTION - Weibull

$$B(X) = 5.00$$

$$C = \frac{\theta - x_0}{\sigma}, \quad A = \frac{x_0 - \mu}{\sigma}$$

\* C

A	* 1.00	2.00	3.00	4.00	5.00	6.00	7.00	8.00	9.00
* .8	.0464	.0078	.0015	.0004	.0001	.0001	.0000	.0000	.0000
* .6	.0687	.0127	.0025	.0007	.0002	.0001	.0000	.0000	.0000
* .4	.0986	.0200	.0042	.0011	.0004	.0002	.0001	.0000	.0000
* .2	.1369	.0307	.0068	.0018	.0006	.0003	.0001	.0001	.0000
* .0	.1844	.0457	.0106	.0029	.0010	.0004	.0002	.0001	.0001
* -.2	.2410	.0662	.0162	.0046	.0016	.0006	.0003	.0002	.0001
* -.4	.3060	.0931	.0243	.0070	.0024	.0010	.0005	.0002	.0001
* -.6	.3776	.1274	.0354	.0105	.0037	.0015	.0007	.0004	.0002
* -.8	.4538	.1697	.0504	.0154	.0055	.0023	.0011	.0005	.0003
* -1.0	.5318	.2201	.0701	.0222	.0080	.0033	.0015	.0008	.0004
* -1.4	.6813	.3430	.1267	.0432	.0160	.0067	.0032	.0016	.0009
* -1.8	.8059	.4856	.2094	.0781	.0301	.0128	.0061	.0031	.0018
* -2.2	.8952	.6304	.3179	.1312	.0531	.0231	.0110	.0057	.0032
* -2.6	.9502	.7588	.4454	.2054	.0881	.0394	.0190	.0100	.0056
* -3.0	.9792	.8583	.5795	.3007	.1383	.0639	.0314	.0165	.0093
* -3.4	.9925	.9256	.7056	.4129	.2054	.0989	.0495	.0263	.0149
* -3.8	.9976	.9653	.8112	.5338	.2894	.1463	.0751	.0404	.0230
* -4.2	.9993	.9857	.8898	.6525	.3878	.2074	.1096	.0599	.0343
* -4.6	.9998	.9948	.9419	.7587	.4952	.2822	.1545	.0860	.0497
* -5.0	1.0000	.9983	.9724	.8450	.6041	.3688	.2105	.1198	.0702
* -5.5	1.0000	.9997	.9907	.9208	.7302	.4883	.2958	.1743	.1040
* -6.0	1.0000	.9999	.9974	.9648	.8336	.6109	.3958	.2430	.1485
* -6.5	1.0000	1.0000	.9994	.9865	.9080	.7251	.5050	.3253	.2046
* -7.0	1.0000	1.0000	.9999	.9956	.9549	.8213	.6157	.4186	.2725
* -8.0	1.0000	1.0000	1.0000	.9997	.9927	.9432	.8091	.6191	.4380
* -9.0	1.0000	1.0000	1.0000	1.0000	.9993	.9883	.9303	.7974	.6216
* -10.0	1.0000	1.0000	1.0000	1.0000	1.0000	.9985	.9823	.9168	.7866

STRESS DISTRIBUTION - Normal  
STRENGTH DISTRIBUTION - Weibull

$B(x) = 6.00$

$C = \frac{\theta-x}{\sigma}, A = \frac{x-\mu}{\sigma}$

A	1.00	2.00	3.00	4.00	5.00	6.00	7.00	8.00	9.00
*	*	*	*	*	*	*	*	*	*
*	*	*	*	*	*	*	*	*	*
*	*	*	*	*	*	*	*	*	*
*	*	*	*	*	*	*	*	*	*
*	*	*	*	*	*	*	*	*	*
0.8	.0446	.0065	.0010	.0002	.0001	.0000	.0000	.0000	.0000
.6	.0664	.0107	.0017	.0003	.0001	.0000	.0000	.0000	.0000
.4	.0957	.0173	.0029	.0006	.0002	.0001	.0000	.0000	.0000
.2	.1335	.0270	.0048	.0010	.0003	.0001	.0000	.0000	.0000
0.0	.1806	.0408	.0078	.0017	.0005	.0002	.0001	.0000	.0000
-.2	.2369	.0601	.0123	.0028	.0008	.0003	.0001	.0000	.0000
-.4	.3017	.0857	.0190	.0044	.0012	.0004	.0002	.0001	.0000
-.6	.3734	.1189	.0285	.0069	.0020	.0007	.0003	.0001	.0001
-.8	.4498	.1603	.0417	.0105	.0030	.0010	.0004	.0002	.0001
-1.0	.5282	.2102	.0594	.0156	.0046	.0016	.0006	.0003	.0001
-1.4	.6789	.3334	.1124	.0325	.0100	.0035	.0014	.0006	.0003
-1.8	.8047	.4782	.1930	.0626	.0202	.0073	.0029	.0013	.0007
-2.2	.8948	.6263	.3021	.1113	.0383	.0141	.0058	.0026	.0013
-2.6	.9502	.7579	.4333	.1830	.0680	.0259	.0108	.0049	.0025
-3.0	.9794	.8594	.5731	.2790	.1134	.0451	.0191	.0088	.0044
-3.4	.9926	.9273	.7048	.3956	.1779	.0746	.0324	.0151	.0076
-3.8	.9977	.9668	.8143	.5236	.2626	.1174	.0525	.0248	.0125
-4.2	.9994	.9865	.8946	.6503	.3654	.1758	.0817	.0393	.0200
-4.6	.9999	.9953	.9463	.7630	.4806	.2510	.1222	.0601	.0309
-5.0	1.0000	.9985	.9756	.8528	.5988	.3419	.1757	.0889	.0464
-5.5	1.0000	.9997	.9923	.9290	.7354	.4714	.2620	.1385	.0739
-6.0	1.0000	1.0000	.9980	.9707	.8448	.6066	.3682	.2055	.1130
-6.5	1.0000	1.0000	.9996	.9898	.9199	.7321	.4883	.2904	.1657
-7.0	1.0000	1.0000	.9999	.9970	.9641	.8352	.6121	.3912	.2334
-8.0	1.0000	1.0000	1.0000	.9999	.9954	.9550	.8250	.6162	.4112
-9.0	1.0000	1.0000	1.0000	1.0000	.9997	.9931	.9466	.8147	.6192
-10.0	1.0000	1.0000	1.0000	1.0000	1.0000	.9994	.9897	.9363	.8047

STRESS DISTRIBUTION - Normal  
STRENGTH DISTRIBUTION - Weibull

$$C = \frac{\theta - x_0}{\sigma}, A = \frac{x_0 - \mu}{\sigma}$$

R(x) = 7.00

\* \* \* \* \*  
\* \* \* \* \*  
\* \* \* \* \*

A	1.00	2.00	3.00	4.00	5.00	6.00	7.00	8.00	9.00
.8	.0433	.0056	.0007	.0001	.0000	.0000	.0000	.0000	.0000
.6	.0647	.0055	.0012	.0002	.0000	.0000	.0000	.0000	.0000
.4	.0936	.0154	.0021	.0004	.0001	.0000	.0000	.0000	.0000
.2	.1310	.0245	.0037	.0006	.0001	.0000	.0000	.0000	.0000
.0	.1777	.0375	.0061	.0011	.0002	.0001	.0000	.0000	.0000
-.2	.2337	.0558	.0099	.0018	.0004	.0001	.0000	.0000	.0000
-.4	.2983	.0806	.0156	.0030	.0007	.0002	.0001	.0000	.0000
-.6	.3701	.1129	.0240	.0048	.0011	.0003	.0001	.0000	.0000
-.8	.4467	.1535	.0359	.0075	.0018	.0005	.0002	.0001	.0000
-1.0	.5253	.2028	.0522	.0116	.0028	.0008	.0003	.0001	.0000
-1.4	.6768	.3260	.1023	.0257	.0066	.0019	.0007	.0003	.0001
-1.8	.8034	.4722	.1810	.0522	.0143	.0043	.0015	.0006	.0003
-2.2	.8942	.6225	.2901	.0972	.0239	.0090	.0032	.0013	.0006
-2.6	.9500	.7563	.4236	.1665	.0544	.0178	.0064	.0026	.0011
-3.0	.9793	.8594	.5673	.2624	.0958	.0330	.0121	.0049	.0022
-3.4	.9926	.9280	.7030	.3818	.1574	.0581	.0219	.0089	.0040
-3.8	.9977	.9675	.8154	.5149	.2417	.0966	.0378	.0157	.0070
-4.2	.9994	.9871	.8970	.6474	.3474	.1520	.0625	.0265	.0120
-4.6	.9999	.9955	.9487	.7648	.4492	.2266	.0987	.0430	.0197
-5.0	1.0000	.9987	.9774	.8573	.5935	.3200	.1491	.0672	.0313
-5.5	1.0000	.9993	.9932	.9338	.7381	.4569	.2348	.1119	.0534
-6.0	1.0000	1.0000	.9983	.9741	.8518	.6020	.3452	.1760	.0871
-6.5	1.0000	1.0000	.9997	.9915	.9273	.7365	.4738	.2617	.1357
-7.0	1.0000	1.0000	.9999	.9977	.9694	.8446	.6083	.3678	.2018
-8.0	1.0000	1.0000	1.0000	.9999	.9967	.9636	.8364	.6130	.3878
-9.0	1.0000	1.0000	1.0000	1.0000	.9998	.9953	.9567	.8277	.6166
-10.0	1.0000	1.0000	1.0000	1.0000	1.0000	.9997	.9933	.9489	.8188

STRESS DISTRIBUTION - Normal  
STRENGTH DISTRIBUTION - Weibull



$$C = \frac{\theta - x_0}{\sigma}, \quad A = \frac{x_0 - \mu}{\sigma}$$

B(X) = 3.00

\*

\*

\*

A	1.00	2.00	3.00	4.00	5.00	6.00	7.00	8.00	9.00
.8	.0423	.0050	.005	.0001	.0000	.0000	.0000	.0000	.0000
.6	.0634	.0086	.009	.0001	.0000	.0000	.0000	.0000	.0000
.4	.0920	.0142	.017	.0002	.0000	.0000	.0000	.0000	.0000
.2	.1291	.0227	.030	.0004	.0001	.0000	.0000	.0000	.0000
.0	.1755	.0351	.050	.0007	.0001	.0000	.0000	.0000	.0000
-.2	.2313	.0523	.083	.0013	.0002	.0001	.0000	.0000	.0000
-.4	.2957	.0768	.134	.0021	.0004	.0001	.0000	.0000	.0000
-.6	.3674	.1084	.209	.0035	.0007	.0002	.0000	.0000	.0000
-.8	.4441	.1484	.318	.0057	.0011	.0003	.0001	.0000	.0000
-1.0	.5229	.1972	.471	.0090	.0018	.0004	.0001	.0000	.0000
-1.4	.6750	.3202	.849	.0211	.0046	.0011	.0003	.0001	.0000
-1.8	.8023	.4673	1.719	.0448	.0105	.0027	.0008	.0003	.0001
-2.2	.8937	.6192	2.808	.0869	.0226	.0060	.0018	.0006	.0003
-2.6	.9498	.7547	4.157	.1540	.0449	.0127	.0039	.0014	.0005
-3.0	.9793	.8590	5.621	.2494	.0828	.0250	.0079	.0028	.0011
-3.4	.9926	.9282	7.008	.3706	.1418	.0464	.0153	.0055	.0022
-3.8	.9977	.9673	8.156	.5074	.2253	.0912	.0280	.0102	.0041
-4.2	.9994	.9874	8.982	.6442	.3327	.1337	.0489	.0183	.0074
-4.6	.9999	.9957	9.501	.7653	.4577	.2072	.0812	.0314	.0128
-5.0	1.0000	.9987	9.734	.8598	.5884	.3020	.1285	.0518	.0215
-5.5	1.0000	.9998	9.936	.9367	.7392	.4444	.2129	.0917	.0393
-6.0	1.0000	1.0000	.9985	.9761	.8562	.5974	.3259	.1525	.0682
-6.5	1.0000	1.0000	.9997	.9925	.9320	.7390	.4611	.2379	.1125
-7.0	1.0000	1.0000	1.0000	.9981	.9727	.8509	.6043	.3477	.1761
-8.0	1.0000	1.0000	1.0000	.9999	.9974	.9684	.8444	.6096	.3674
-9.0	1.0000	1.0000	1.0000	1.0000	.9999	.9965	.9633	.8372	.6137
-10.0	1.0000	1.0000	1.0000	1.0000	1.0000	.9998	.9952	.9573	.8296

STRESS DISTRIBUTION - Normal  
STRENGTH DISTRIBUTION - Weibull

B(X) = 9.00

$$C = \frac{\theta - x_0}{\sigma}, \quad A = \frac{x_0 - \mu}{\sigma}$$

\* \* \*  
\* \* \* C

A	1.00	2.00	3.00	4.00	5.00	6.00	7.00	8.00	9.00
* * *									
*									
* .8	.0416	.0046	.0004	.0000	.0000	.0000	.0000	.0000	.0000
* .6	.0624	.0079	.0008	.0001	.0000	.0000	.0000	.0000	.0000
* .4	.0907	.0133	.0014	.0001	.0000	.0000	.0000	.0000	.0000
* .2	.1276	.0214	.0025	.0003	.0000	.0000	.0000	.0000	.0000
* .0	.1737	.0334	.0043	.0005	.0001	.0000	.0000	.0000	.0000
* -.2	.2293	.0505	.0072	.0009	.0001	.0000	.0000	.0000	.0000
* -.4	.2936	.0739	.0118	.0016	.0002	.0000	.0000	.0000	.0000
* -.6	.3653	.1049	.0187	.0027	.0004	.0001	.0000	.0000	.0000
* -.8	.4420	.1444	.0289	.0045	.0007	.0002	.0000	.0000	.0000
* -1.0	.5209	.1929	.0433	.0073	.0012	.0003	.0001	.0000	.0000
* -1.4	.6734	.3155	.0893	.0178	.0033	.0007	.0002	.0001	.0000
* -1.8	.8013	.4631	.1649	.0395	.0081	.0018	.0005	.0001	.0000
* -2.2	.8931	.6162	.2733	.0792	.0182	.0042	.0011	.0003	.0001
* -2.6	.9495	.7530	.4092	.1443	.0320	.0093	.0025	.0008	.0003
* -3.0	.9792	.8584	.5575	.2390	.0730	.0195	.0054	.0017	.0006
* -3.4	.9925	.9282	.6986	.3613	.1296	.0380	.0110	.0035	.0012
* -3.8	.9977	.9680	.8151	.5008	.2121	.0696	.0213	.0068	.0024
* -4.2	.9994	.9875	.8988	.6410	.3206	.1194	.0391	.0129	.0046
* -4.6	.9999	.9958	.9509	.7650	.4486	.1915	.0681	.0234	.0085
* -5.0	1.0000	.9987	.9700	.8612	.5836	.2870	.1125	.0407	.0151
* -5.5	1.0000	.9998	.9939	.9385	.7393	.4336	.1949	.0764	.0294
* -6.0	1.0000	1.0000	.9986	.9773	.8590	.5929	.3095	.1337	.0542
* -6.5	1.0000	1.0000	.9997	.9931	.9351	.7402	.4499	.2181	.0944
* -7.0	1.0000	1.0000	1.0000	.9983	.9749	.8552	.6003	.3304	.1552
* -8.0	1.0000	1.0000	1.0000	.9999	.9978	.9716	.8501	.6060	.3496
* -9.0	1.0000	1.0000	1.0000	1.0000	.9999	.9972	.9676	.8443	.6106
* -10.0	1.0000	1.0000	1.0000	1.0000	1.0000	.9999	.9963	.9630	.8379

STRESS DISTRIBUTION - Normal  
STRENGTH DISTRIBUTION - Weibull

$B(X) = 10.00$

$C = \frac{\theta - x_0}{\sigma}, A = \frac{x_0 - \mu}{\sigma}$

\* \* \* C

A	1.00	2.00	3.00	4.00	5.00	6.00	7.00	8.00	9.00
* .8	.0410	.0043	.0003	.0000	.0000	.0000	.0000	.0000	.0000
* .6	.0616	.0075	.0006	.0001	.0000	.0000	.0000	.0000	.0000
* .4	.0997	.0126	.0012	.0001	.0000	.0000	.0000	.0000	.0000
* .2	.1263	.0204	.0021	.0002	.0000	.0000	.0000	.0000	.0000
* .0	.1723	.0320	.0037	.0004	.0000	.0000	.0000	.0000	.0000
* -.2	.2277	.0487	.0064	.0007	.0001	.0000	.0000	.0000	.0000
* -.4	.2919	.0717	.0106	.0013	.0002	.0000	.0000	.0000	.0000
* -.6	.3635	.1022	.0171	.0022	.0003	.0000	.0000	.0000	.0000
* -.8	.4402	.1412	.0267	.0037	.0005	.0001	.0000	.0000	.0000
* -1.0	.5192	.1893	.0404	.0061	.0009	.0002	.0000	.0000	.0000
* -1.4	.6721	.3117	.0850	.0155	.0025	.0004	.0001	.0000	.0000
* -1.8	.8004	.4597	.1593	.0355	.0064	.0012	.0003	.0001	.0000
* -2.2	.8926	.6136	.2672	.0732	.0151	.0030	.0007	.0002	.0001
* -2.6	.9493	.7515	.4037	.1366	.0329	.0071	.0016	.0004	.0001
* -3.0	.9791	.8577	.5535	.2306	.0656	.0155	.0038	.0010	.0003
* -3.4	.9925	.9280	.6964	.3535	.1200	.0318	.0081	.0022	.0007
* -3.8	.9977	.9680	.8145	.4950	.2014	.0608	.0165	.0047	.0015
* -4.2	.9994	.9876	.8990	.5379	.3104	.1081	.0318	.0094	.0030
* -4.6	.9999	.9958	.9513	.7642	.4407	.1787	.0580	.0178	.0058
* -5.0	1.0000	.9988	.9794	.8619	.5791	.2745	.0997	.0325	.0108
* -5.5	1.0000	.9998	.9941	.9397	.7388	.4242	.1801	.0645	.0224
* -6.0	1.0000	1.0000	.9987	.9782	.8608	.5886	.2956	.1186	.0436
* -6.5	1.0000	1.0000	.9998	.9935	.9372	.7405	.4400	.2015	.0801
* -7.0	1.0000	1.0000	1.0000	.9984	.9763	.8581	.5962	.3154	.1379
* -8.0	1.0000	1.0000	1.0000	1.0000	.9981	.9738	.8542	.6024	.3339
* -9.0	1.0000	1.0000	1.0000	1.0000	.9999	.9976	.9707	.8495	.6074
* -10.0	1.0000	1.0000	1.0000	1.0000	1.0000	.9999	.9970	.8967	.8442

STRESS DISTRIBUTION - Normal  
STRENGTH DISTRIBUTION - Weibull

A-2.3 STRESS DISTRIBUTION - NORMAL  
STRENGTH DISTRIBUTION - NORMAL

A-2.3.1 Stress Standard Deviation = 0

## TABLES OF INTERFERENCE

Stress Distribution: Normal

Strength Distribution: Normal

$$\mu_y = S_{\text{equ}} \quad (\text{Equivalent Stress})$$

$\mu_x$  Depend on the material and the operating conditions

$$\sigma_y = 0$$

$$\sigma_x$$

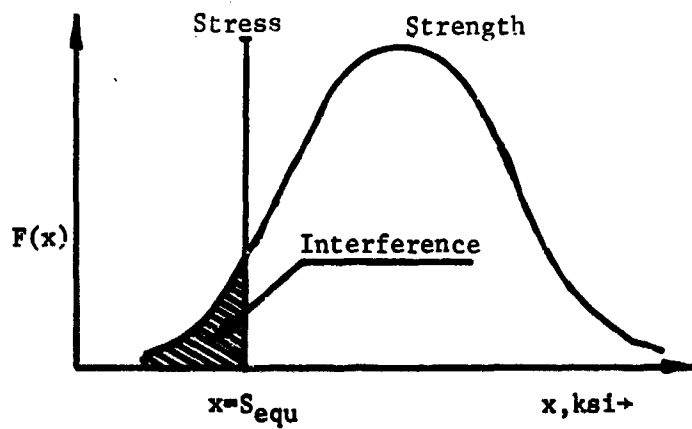

Figure A-2.3 Interference With Standard Deviation of Stress Equal to Zero

The interference is the area under the standardized normal curve corresponding to the value of the standardized normal variate,  $z$ , determined from Equation (2.1) in Section 2.

$$z = \frac{|\mu_y - \mu_x|}{\sqrt{\sigma_x^2 + \sigma_y^2}} = \frac{|S_{\text{equ}} - \mu_x|}{\sigma_x}$$

The value of interference corresponding to the value of  $z$  can be obtained from Table 2.1 (in Section 2) of  $\alpha$  vs.  $K_0$  where:

$$\alpha = \text{interference}$$

$$K_0 = z$$

A-2.3.2 Stress Standard Deviation  $\neq 0$

## TABLE OF INTERFERENCE

Stress Distribution: Normal

Strength Distribution: Normal

 $\mu_y = S_{\text{equ}}$  (Equivalent Stress) $\mu_x$  Depend on the material and the operating conditions $\sigma_y \neq 0$  $\sigma_x$ 

Figure A-2.4 Interference with Standard Deviation of Stress Not Equal to Zero

The interference is the area under the standardized normal curve corresponding to the value of standardized normal variate,  $z$ , determined from the Equation (2.1) in Section 2.

$$z = \frac{|\mu_y - \mu_x|}{\sqrt{\sigma_x^2 + \sigma_y^2}}$$

The value of interference corresponding to the value of  $z$  can be obtained from Table 2.1 (in Section 2) of  $\alpha$  vs.  $K_\alpha$  where:

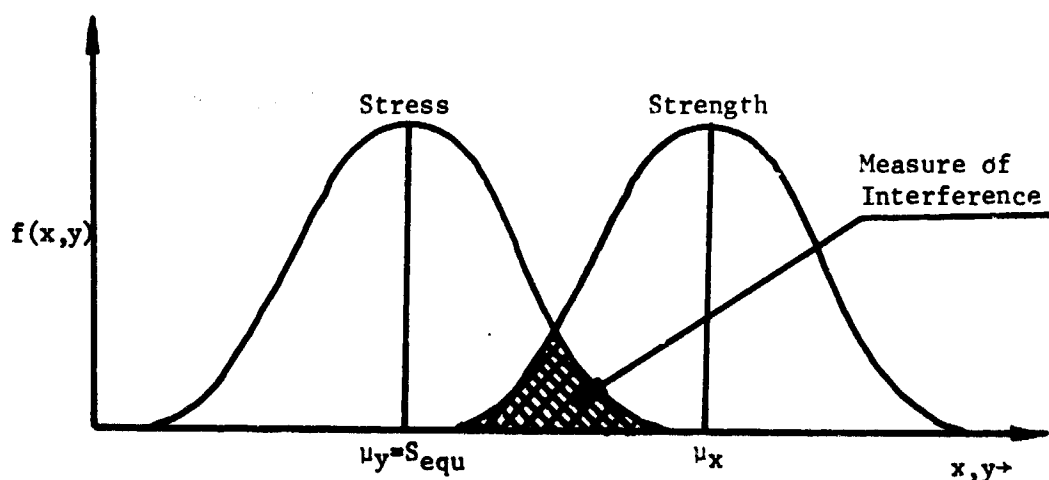
$\alpha$  = interference

$K_\alpha = z$



A-2.4 STRESS DISTRIBUTION - NORMAL

STRENGTH DISTRIBUTION - LARGEST EXTREME VALUE

A-2.4.1 STRESS STANDARD DEVIATION = 0

## TABLES OF INTERFERENCE [F(X)]

Stress Distribution: Normal

Strength Distribution: Largest Extreme Value

 $\mu = S_{equ}$  (Equivalent Stress)

M

Depend on the material  
and the operating conditions $\sigma = 0$  $\beta$ 

Figure A-2.5 Interference With Standard Deviation of Stress Equal to Zero

Density function of Largest Extreme Value is:

$$f(x) = \beta e^{-\beta(x-M)} \cdot e^{-e^{-\beta(x-M)}}$$

Cumulative distribution function,  $F(x) = \int_{-\infty}^x f(x) dx$ 

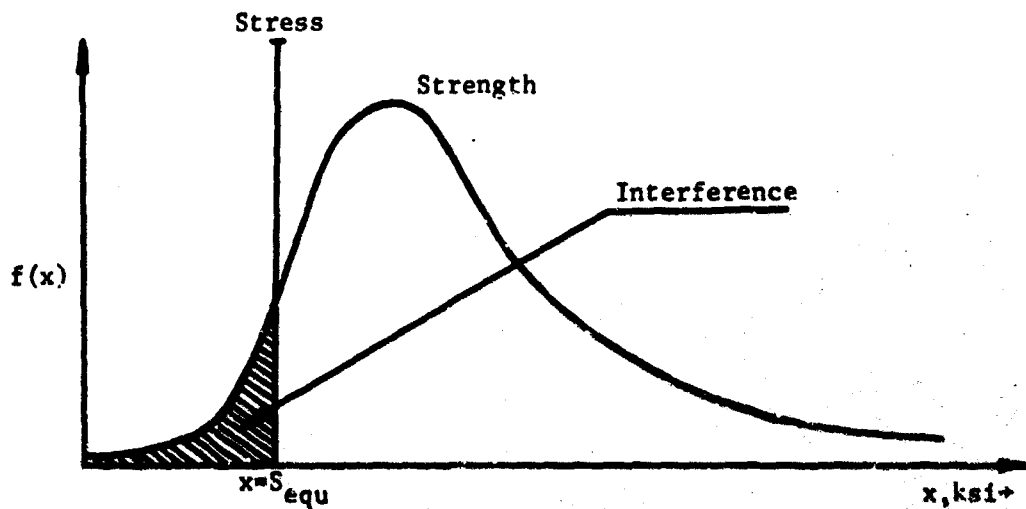
$$\text{Let } y = -e^{-\beta(x-M)} \text{, } dy = +\beta e^{-\beta(x-M)} dx$$

$$F(x=S_{equ}) = \int_{-\infty}^{-B(S_{equ}-M)} e^{+y} dy = e^{+y} \Big|_{-\infty}^{-B(S_{equ}-M)} = e^{-e^{-B(S_{equ}-M)}}$$

$$F(X) = e^{-e^{-X}} \text{ where } X = -B(S_{equ}-M)$$

X	Interference F(X)	X	Interference F(X)
0.00	.3679	1.15	.0425
0.05	.3495	1.20	.0361
0.10	.3312	1.25	.0305
0.15	.3129	1.30	.6255
0.20	.2948	1.35	.0211
0.25	.2769	1.40	.0173
0.30	.2593	1.45	.0141
0.35	.2419	1.50	.0113
0.40	.2249	1.55	.0090
0.45	.2084	1.60	.0071
0.50	.1923	1.65	.0055
0.55	.1767	1.70	.0042
0.60	.1617	1.75	.0032
0.65	.1473	1.80	.0024
0.70	.1335	1.85	.0017
0.75	.1204	1.90	.0012
0.80	.1080	1.95	.0009
0.85	.0964	2.00	.0006
0.90	.0855	2.05	.0004
0.95	.0753	2.10	.0003
1.00	.0660	2.15	.0002
1.05	.0574	2.20	.0001
1.10	.0496	2.25	.0000

Where  $X = -\beta(S_{\text{edu}} - M)$

STRESS DISTRIBUTION - NORMAL ( $\sigma = 0$ )

STRENGTH DISTRIBUTION - LARGEST EXTREME VALUE

A-2.4.2 Stress Standard Deviation  $\neq 0$

### TABLES OF INTERFERENCE

Stress Distribution: Normal

Strength Distribution: Largest Extreme Value

$\mu = S_{equ}$  (Equivalent Stress)

M Depend on the material and the operating conditions

$\sigma \neq 0$

$\beta$

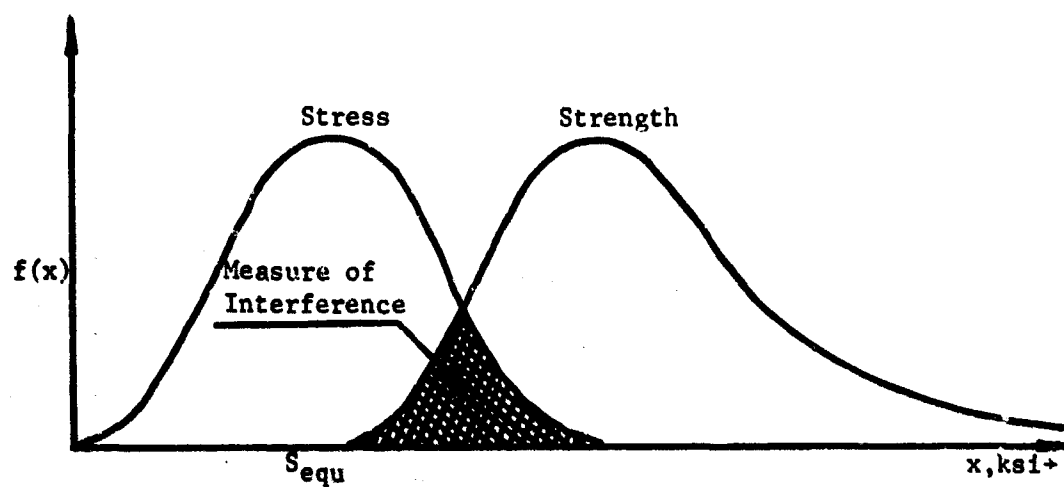

Figure A-2.6 Interference with Standard Deviation of Stress Not Equal to Zero

$\alpha = \beta\sigma, \gamma = \beta(\mu-M)$

$\gamma$	0.001	0.005	0.010	0.025	0.050	0.075	0.100	0.200	0.300	0.400
*	0.001	0.005	0.010	0.025	0.050	0.075	0.100	0.200	0.300	0.400
*	0.3679	0.3679	0.3679	0.3679	0.3679	0.3679	0.3679	0.3679	0.3682	0.3688
*	0.0660	0.0660	0.0660	0.0661	0.0664	0.0669	0.0675	0.0719	0.0789	0.0877
*	0.0006	0.0006	0.0006	0.0006	0.0007	0.0007	0.0008	0.0013	0.0024	0.0044
*	0.0	0.0	0.0	0.0	0.0	0.0	0.0	0.0000	0.0000	0.0000

For  $\alpha = 0$ , Interference =  $e^{-\gamma}$

$\alpha = \beta\sigma, \gamma = \beta(\mu-M)$

$\gamma$	0.500	0.600	0.700	0.800	0.900	1.000	1.100	1.200	1.300	1.400
*	0.500	0.600	0.700	0.800	0.900	1.000	1.100	1.200	1.300	1.400
*	0.3699	0.3714	0.3735	0.3760	0.3787	0.3818	0.3849	0.3881	0.3914	0.3946
*	0.0980	0.1092	0.1210	0.1330	0.1451	0.1570	0.1687	0.1800	0.1909	0.2014
*	0.0075	0.0116	0.0170	0.0235	0.0310	0.0392	0.0481	0.0575	0.0672	0.0771
*	0.0001	0.0003	0.0008	0.0017	0.0032	0.0054	0.0083	0.0119	0.0162	0.0212
*	0.0000	0.0000	0.0000	0.0000	0.0001	0.0004	0.0008	0.0015	0.0026	0.0041
*	0.0	0.0000	0.0000	0.0000	0.0000	0.0000	0.0000	0.0001	0.0003	0.0005
*	0.0	0.0	0.0	0.0000	0.0000	0.0000	0.0000	0.0000	0.0000	0.0000

For  $\alpha = 0$ , Interference =  $e^{-\gamma}$

STRESS DISTRIBUTION - NORMAL  
STRENGTH DISTRIBUTION - LARGEST EXTREME VALUE

$\gamma$	$\alpha$	1.500	1.600	1.700	1.800	1.900	2.000	2.100	2.200	2.300	2.400
0.	*	.3977	.4008	.4038	.4067	.4095	.4122	.4147	.4172	.4195	.4218
-1.	*	.2115	.2211	.2303	.2391	.2474	.2554	.2629	.2701	.2769	.2834
-2.	*	.0871	.0970	.1069	.1167	.1263	.1357	.1448	.1537	.1623	.1706
-3.	*	.0268	.0329	.0395	.0463	.0535	.0609	.0684	.0760	.0836	.0912
-4.	*	.0060	.0084	.0113	.0147	.0185	.0228	.0274	.0323	.0375	.0429
-5.	*	.0010	.0016	.0025	.0037	.0052	.0070	.0092	.0117	.0145	.0177
-6.	*	.0001	.0002	.0004	.0007	.0012	.0018	.0026	.0036	.0048	.0063
-7.	*	.0000	.0000	.0001	.0001	.0002	.0004	.0006	.0009	.0014	.0020
-8.	*	.0000	.0000	.0000	.0000	.0000	.0001	.0001	.0002	.0003	.0005
-9.	*	.0000	.0000	.0000	.0000	.0000	.0000	.0000	.0000	.0001	.0001
-10.	*	.0	.0000	.0000	.0000	.0000	.0000	.0000	.0000	.0000	.0000

For  $\sigma = 0$ , Interference =  $e^{-\gamma}$

STRESS DISTRIBUTION - NORMAL  
 STRENGTH DISTRIBUTION - LARGEST EXTREME VALUE



$\alpha = \beta\sigma, \gamma = \beta(\mu - M)$

$\gamma$	2.500	2.600	2.700	2.800	2.900	3.000	3.500	4.000	4.500	5.000
0.	.4240	.4260	.4280	.4299	.4317	.4334	.4410	.4472	.4523	.4555
-1.	.2896	.2955	.3011	.3065	.3116	.3165	.3378	.3550	.3691	.3808
-2.	.1787	.1865	.1940	.2013	.2083	.2150	.2453	.2705	.2916	.3094
-3.	.0988	.1063	.1137	.1210	.1282	.1353	.1633	.1973	.2225	.2444
-4.	.0485	.0543	.0603	.0663	.0723	.0784	.1087	.1374	.1638	.1876
-5.	.0211	.0248	.0287	.0329	.0372	.0417	.0660	.0913	.1162	.1397
-6.	.0081	.0100	.0123	.0147	.0174	.0203	.0375	.0578	.0763	.1009
-7.	.0027	.0036	.0047	.0050	.0074	.0090	.0200	.0347	.0520	.0716
-8.	.0008	.0011	.0016	.0022	.0028	.0037	.0099	.0198	.0328	.0478
-9.	.0002	.0003	.0005	.0007	.0010	.0014	.0046	.0107	.0198	.0313
-10.	.0000	.0001	.0001	.0002	.0003	.0005	.0020	.0055	.0115	.0198
-11.	.0000	.0000	.0000	.0001	.0001	.0001	.0008	.0027	.0064	.0121
-12.	.0000	.0000	.0000	.0000	.0000	.0000	.0003	.0012	.0034	.0072
-13.	.0000	.0000	.0000	.0000	.0000	.0000	.0001	.0005	.0017	.0041
-14.	.0000	.0000	.0000	.0000	.0000	.0000	.0000	.0002	.0008	.0023
-15.	.0000	.0000	.0000	.0000	.0000	.0000	.0000	.0001	.0004	.0012
-16.	.0000	.0000	.0000	.0000	.0000	.0000	.0000	.0000	.0002	.0006
-17.	.0000	.0000	.0000	.0000	.0000	.0000	.0000	.0000	.0001	.0003
-18.	.0000	.0000	.0000	.0000	.0000	.0000	.0000	.0000	.0000	.0001
-19.	.0000	.0000	.0000	.0000	.0000	.0000	.0000	.0000	.0000	.0001
-20.	.0000	.0000	.0000	.0000	.0000	.0000	.0000	.0000	.0000	.0000

For  $\alpha = 0$ , Interference =  $e^{-e^{-\gamma}}$

STRESS DISTRIBUTION - NORMAL  
STRENGTH DISTRIBUTION - LARGEST EXTREME VALUE

$\alpha = \beta\sigma, \gamma = \beta(\mu - M)$

\* \*  $\alpha$

$\gamma$	5.500	6.000	6.500	7.000	7.500	8.000	8.500	9.000	9.500	10.000
0.	.4601	.4632	.4658	.4681	.4701	.4719	.4735	.4749	.4762	.4773
-1.	.3907	.3991	.4064	.4127	.4182	.4231	.4274	.4313	.4348	.4380
-2.	.3246	.3377	.3490	.3589	.3677	.3754	.3824	.3886	.3942	.3993
-3.	.2635	.2802	.2949	.3078	.3194	.3296	.3388	.3471	.3547	.3615
-4.	.2089	.2280	.2450	.2602	.2739	.2862	.2973	.3074	.3166	.3250
-5.	.1616	.1817	.2000	.2167	.2319	.2457	.2583	.2699	.2804	.2902
-6.	.1219	.1417	.1604	.1777	.1937	.2085	.2222	.2348	.2464	.2571
-7.	.0895	.1082	.1263	.1434	.1596	.1748	.1891	.2023	.2147	.2262
-8.	.0640	.0808	.0975	.1139	.1297	.1448	.1592	.1727	.1855	.1975
-9.	.0446	.0590	.0739	.0890	.1040	.1185	.1326	.1460	.1589	.1711
-10.	.0302	.0421	.0549	.0684	.0821	.0958	.1092	.1223	.1349	.1470
-11.	.0199	.0293	.0400	.0517	.0639	.0764	.0889	.1014	.1135	.1254
-12.	.0127	.0199	.0286	.0384	.0490	.0602	.0716	.0832	.0947	.1061
-13.	.0079	.0132	.0200	.0280	.0370	.0468	.0570	.0676	.0783	.0890
-14.	.0048	.0086	.0137	.0201	.0275	.0359	.0449	.0543	.0641	.0740
-15.	.0028	.0054	.0092	.0142	.0202	.0271	.0349	.0432	.0520	.0611
-16.	.0016	.0034	.0061	.0098	.0146	.0203	.0268	.0340	.0418	.0500
-17.	.0009	.0020	.0039	.0067	.0103	.0149	.0203	.0265	.0333	.0406
-18.	.0005	.0012	.0025	.0044	.0072	.0108	.0153	.0204	.0262	.0326
-19.	.0002	.0007	.0015	.0029	.0050	.0078	.0113	.0156	.0205	.0260

For  $\alpha = 0$ , Interference =  $e^{-\gamma}$  (Continued on the next Table.)

STRESS DISTRIBUTION - NORMAL  
STRENGTH DISTRIBUTION - LARGEST EXTREME VALUE

$\alpha = \beta\sigma, \gamma = \beta(\mu - M)$

Y	5.500	6.000	6.500	7.000	7.500	8.000	8.500	9.000	9.500	10.000
* -20.	* .0001	* .0004	* .0009	* .0019	* .0034	* .0055	* .0083	* .0117	* .0159	* .0206
* -21.	* .0001	* .0002	* .0005	* .0012	* .0022	* .0038	* .0060	* .0088	* .0121	* .0161
* -22.	* .0000	* .0001	* .0003	* .0007	* .0015	* .0026	* .0043	* .0065	* .0092	* .0125
* -23.	* .0000	* .0001	* .0002	* .0004	* .0010	* .0018	* .0030	* .0047	* .0069	* .0096
* -24.	* .0000	* .0000	* .0001	* .0003	* .0006	* .0012	* .0021	* .0034	* .0051	* .0074
* -25.	* .0000	* .0000	* .0001	* .0002	* .0004	* .0008	* .0014	* .0024	* .0038	* .0056
* -26.	* .0000	* .0000	* .0000	* .0001	* .0002	* .0005	* .0010	* .0017	* .0028	* .0042
* -27.	* .0000	* .0000	* .0000	* .0001	* .0001	* .0003	* .0007	* .0012	* .0020	* .0031
* -28.	* .0000	* .0000	* .0000	* .0000	* .0001	* .0002	* .0004	* .0008	* .0014	* .0023
* -29.	* .0000	* .0000	* .0000	* .0000	* .0000	* .0001	* .0003	* .0006	* .0010	* .0017
* -30.	* .0	* .0000	* .0000	* .0000	* .0000	* .0001	* .0002	* .0004	* .0007	* .0012
* -31.	* .0	* .0000	* .0000	* .0000	* .0000	* .0000	* .0001	* .0003	* .0005	* .0009
* -32.	* .0	* .0000	* .0000	* .0000	* .0000	* .0000	* .0001	* .0002	* .0003	* .0006
* -33.	* .0	* .0	* .0000	* .0000	* .0000	* .0000	* .0000	* .0001	* .0002	* .0004
* -34.	* .0	* .0	* .0000	* .0000	* .0000	* .0000	* .0000	* .0001	* .0002	* .0003
* -35.	* .0	* .0	* .0	* .0000	* .0000	* .0000	* .0000	* .0000	* .0001	* .0002
* -36.	* .0	* .0	* .0	* .0000	* .0000	* .0000	* .0000	* .0000	* .0001	* .0001
* -37.	* .0	* .0	* .0	* .0000	* .0000	* .0000	* .0000	* .0000	* .0000	* .0001
* -38.	* .0	* .0	* .0	* .0	* .0	* .0000	* .0000	* .0000	* .0000	* .0001
* -39.	* .0	* .0	* .0	* .0	* .0000	* .0000	* .0000	* .0000	* .0000	* .0000

For  $\alpha = 0$ , Interference =  $e^{-\gamma}$

STRESS DISTRIBUTION - NORMAL  
STRENGTH DISTRIBUTION - LARGEST EXTREME VALUE

A-2.5 STRESS DISTRIBUTION - NORMAL  
STRENGTH DISTRIBUTION - SMALLEST EXTREME VALUE

A-2.5.1 Stress Standard Deviation = 0

## TABLES OF INTERFERENCE [F(X)]

Stress Distribution: Normal

Strength Distribution: Smallest Extreme Value

$\mu = S_{equ}$  (Equivalent Stress)  
 $\sigma = 0$

M Depend on the material and the operating conditions  
 $\beta$

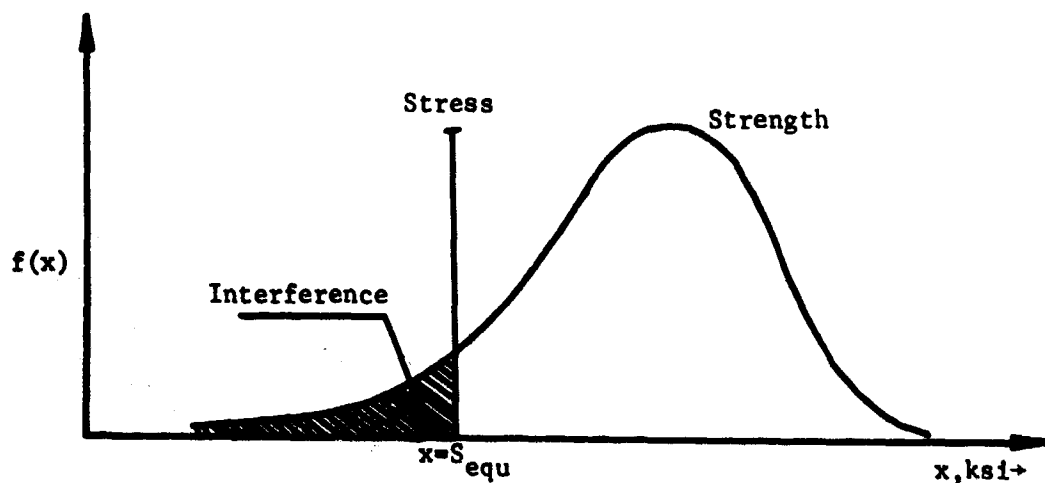

Figure A-2.7 Interference with Standard Deviation of Stress Equal to Zero

Density Function of Smallest Extreme Value is:

$$f(x) = \beta e^{-\beta(x-M)} \cdot e^{-e^{-\beta(x-M)}}$$

Cumulative Distribution Function,  $F(x) = \int_{-\infty}^x f(x) dx$

$$\text{Let } y = -e^{-\beta(x-M)} \therefore dy = \beta e^{-\beta(x-M)} dx$$

$$F(x=S_{equ}) = \int_0^{-e^{-\beta(S_{equ}-M)}} -e^y dy = -e^y \Big|_0^{-e^{-\beta(S_{equ}-M)}} = 1 - e^{-e^{-\beta(S_{equ}-M)}}$$

$$F(X) = 1 - e^{-e^{-X}}$$

$$\text{where } X = -\beta(S_{equ}-M)$$

X	Interference F(X)	X	Interference F(X)
0.0	.6321	2.8	.0590
0.1	.5954	2.9	.0540
0.2	.5590	3.0	.0459
0.3	.5233	3.1	.0441
0.4	.4884	3.2	.0400
0.5	.4548	3.3	.0362
0.6	.4224	3.4	.0328
0.7	.3914	3.5	.0298
0.8	.3619	3.6	.0270
0.9	.3341	3.7	.0244
1.0	.3078	3.8	.0221
1.1	.2831	3.9	.0200
1.2	.2601	4.0	.0182
1.3	.2385	4.2	.0149
1.4	.2185	4.4	.0122
1.5	.2000	4.6	.0100
1.6	.1829	4.8	.0082
1.7	.1669	5.0	.0067
1.8	.1524	5.2	.0055
1.9	.1389	5.4	.0045
2.0	.1266	5.6	.0037
2.1	.1153	5.8	.0030
2.2	.1049	6.0	.0025
2.3	.0954	6.2	.0020
2.4	.0868	6.4	.0017
2.5	.0788	6.6	.0014
2.6	.0716	6.8	.0011
2.7	.0650		

STRESS DISTRIBUTION - NORMAL ( $\sigma=0$ )

STRENGTH DISTRIBUTION - SMALLEST EXTREME VALUE

A-2.5.2 Stress Standard Deviation  $\neq 0$



TABLES OF INTERFERENCE

Stress Distribution: Normal

Strength Distribution: Smallest Extreme Value

$\mu = S_{equ}$  (Equivalent Stress)

$\sigma \neq 0$

M Depend on the material and the operating conditions

$\beta$

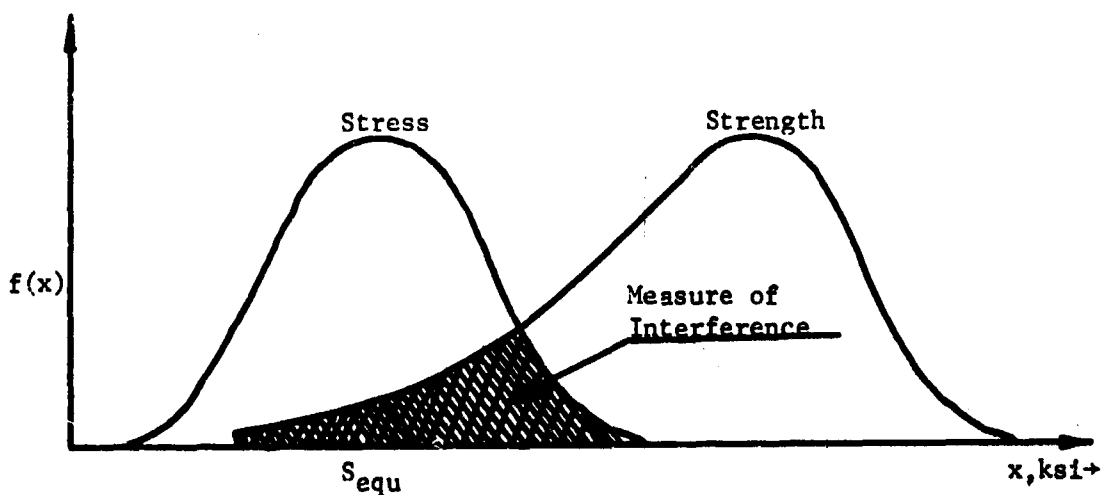

Figure A-2.8 Interference with Standard Deviation of Stress Not Equal to Zero

$\alpha = \beta\sigma, \gamma = \beta(\mu - M)$

$\gamma$	0.001	0.005	0.010	0.025	0.050	0.075	0.100	0.120	0.200	0.300	0.400
0.	.6321	.6321	.6321	.6321	.6321	.6321	.6321	.6321	.6321	.6318	.6312
-1.	.3078	.3078	.3078	.3079	.3080	.3083	.3086	.3110	.3110	.3148	.3200
-2.	.1266	.1266	.1266	.1266	.1267	.1269	.1271	.1286	.1286	.1312	.1348
-3.	.0486	.0486	.0486	.0486	.0486	.0487	.0487	.0495	.0495	.0506	.0523
-4.	.0182	.0182	.0182	.0182	.0182	.0182	.0182	.0185	.0185	.0190	.0196
-5.	.0067	.0067	.0067	.0067	.0067	.0067	.0068	.0069	.0069	.0070	.0073
-6.	.0025	.0025	.0025	.0025	.0025	.0025	.0025	.0026	.0026	.0026	.0027
-7.	.0009	.0009	.0009	.0009	.0009	.0009	.0009	.0009	.0009	.0010	.0010
-8.	.0003	.0003	.0003	.0003	.0003	.0003	.0003	.0003	.0003	.0004	.0004
-9.	.0001	.0001	.0001	.0001	.0001	.0001	.0001	.0001	.0001	.0001	.0001
-10.	.0001	.0001	.0001	.0001	.0001	.0001	.0001	.0001	.0001	.0001	.0001
-11.	.0000	.0000	.0000	.0000	.0000	.0000	.0000	.0000	.0000	.0000	.0000

For  $\alpha = 0$ , Interference =  $1 - e^{-e^{\gamma}}$

$\alpha = \beta\sigma, \gamma = \beta(\mu - M)$

$\gamma$	0.500	0.600	0.700	0.800	0.900	1.000	1.100	1.200	1.300	1.400
0.	.6301	.6286	.6265	.6240	.6213	.6182	.6151	.6119	.6086	.6054
-1.	.3263	.3333	.3409	.3487	.3565	.3641	.3714	.3782	.3847	.3907
-2.	.1394	.1451	.1517	.1592	.1674	.1761	.1853	.1948	.2043	.2139
-3.	.0544	.0572	.0605	.0644	.0691	.0743	.0802	.0868	.0938	.1013
-4.	.0205	.0216	.0230	.0246	.0267	.0290	.0318	.0351	.0388	.0430
-5.	.0076	.0080	.0086	.0092	.0100	.0110	.0121	.0135	.0151	.0170
-6.	.0028	.0030	.0032	.0034	.0037	.0041	.0045	.0050	.0057	.0065
-7.	.0010	.0011	.0012	.0013	.0014	.0015	.0017	.0019	.0021	.0024
-8.	.0004	.0004	.0004	.0005	.0005	.0006	.0006	.0007	.0008	.0009
-9.	.0001	.0002	.0002	.0002	.0002	.0002	.0002	.0003	.0003	.0003
-10.	.0001	.0001	.0001	.0001	.0001	.0001	.0001	.0001	.0001	.0001
-11.	.0000	.0000	.0000	.0000	.0000	.0000	.0000	.0000	.0000	.0000

For  $\alpha = 0$ , Interference =  $1 - e^{-e^{\gamma}}$

STRESS DISTRIBUTION - NORMAL

STRENGTH DISTRIBUTION - SMALLEST EXTREME VALUE

$\alpha = \beta\sigma, \gamma = \beta(\mu - M)$

* #	$\alpha$	1.500	1.600	1.700	1.800	1.900	2.000	2.100	2.200	2.300	2.400
Y	*	1.500	1.600	1.700	1.800	1.900	2.000	2.100	2.200	2.300	2.400
0.	*	.6023	.5992	.5962	.5933	.5905	.5878	.5853	.5828	.5805	.5782
-1.	*	.3963	.4014	.4062	.4106	.4147	.4184	.4219	.4251	.4281	.4309
-2.	*	.2233	.2324	.2413	.2499	.2582	.2661	.2737	.2809	.2878	.2943
-3.	*	.1092	.1174	.1257	.1341	.1426	.1510	.1594	.1676	.1757	.1836
-4.	*	.0477	.0523	.0583	.0642	.0705	.0769	.0836	.0905	.0975	.1045
-5.	*	.0192	.0218	.0247	.0280	.0316	.0356	.0399	.0445	.0494	.0545
-6.	*	.0074	.0085	.0098	.0114	.0132	.0152	.0176	.0202	.0230	.0262
-7.	*	.0028	.0032	.0038	.0044	.0052	.0061	.0072	.0085	.0100	.0117
-8.	*	.0010	.0012	.0014	.0017	.0020	.0024	.0029	.0034	.0041	.0049
-9.	*	.0004	.0004	.0005	.0006	.0007	.0009	.0011	.0013	.0016	.0020
-10.	*	.0001	.0002	.0002	.0002	.0003	.0003	.0004	.0005	.0006	.0008
-11.	*	.0001	.0001	.0001	.0001	.0001	.0001	.0002	.0002	.0002	.0003
-12.	*	.0000	.0000	.0000	.0000	.0000	.0000	.0001	.0001	.0001	.0001
-13.	*	.0000	.0000	.0000	.0000	.0000	.0000	.0000	.0000	.0000	.0000

For  $\alpha = 0$ , Interference =  $1 - e^{-y}$

STRESS DISTRIBUTION - NORMAL  
STRENGTH DISTRIBUTION - SMALLEST EXTREME VALUE

$\sigma = \beta\sigma, \gamma = \beta(\mu - M)$

$\gamma$	2.500	2.600	2.700	2.800	2.900	3.000	3.500	4.000	4.500	5.000
* 0.	.5760	.5740	.5720	.5701	.5683	.5666	.5590	.5528	.5477	.5435
* -1.	.4335	.4359	.4382	.4405	.4423	.4441	.4519	.4579	.4625	.4663
* -2.	.3006	.3065	.3121	.3175	.3227	.3275	.3487	.3655	.3791	.3904
* -3.	.1913	.1987	.2060	.2130	.2198	.2263	.2559	.2805	.3011	.3185
* -4.	.1116	.1187	.1257	.1326	.1395	.1463	.1783	.2067	.2315	.2530
* -5.	.0598	.0553	.0709	.0757	.0825	.0883	.1173	.1459	.1719	.1954
* -6.	.0296	.0332	.0371	.0412	.0454	.0499	.0737	.0987	.1233	.1467
* -7.	.0136	.0157	.0181	.0206	.0234	.0263	.0436	.0638	.0853	.1068
* -8.	.0059	.0070	.0083	.0097	.0113	.0131	.0245	.0395	.0569	.0756
* -9.	.0024	.0029	.0036	.0043	.0051	.0061	.0130	.0234	.0366	.0518
* -10.	.0010	.0012	.0015	.0018	.0022	.0027	.0066	.0132	.0227	.0345
* -11.	.0004	.0005	.0006	.0007	.0009	.0012	.0032	.0072	.0135	.0222
* -12.	.0001	.0002	.0002	.0003	.0004	.0005	.0015	.0037	.0078	.0139
* -13.	.0001	.0001	.0001	.0001	.0001	.0002	.0006	.0019	.0043	.0084
* -14.	.0000	.0000	.0000	.0000	.0001	.0001	.0003	.0009	.0023	.0049
* -15.	.0000	.0000	.0000	.0000	.0000	.0000	.0001	.0004	.0012	.0028
* -16.	.0000	.0000	.0000	.0000	.0000	.0000	.0000	.0002	.0006	.0015
* -17.	.0000	.0000	.0000	.0000	.0000	.0000	.0000	.0001	.0003	.0008
* -18.	.0000	.0000	.0000	.0000	.0000	.0000	.0000	.0000	.0001	.0004
* -19.	.0000	.0000	.0000	.0000	.0000	.0000	.0000	.0000	.0001	.0002
* -20.	.0000	.0000	.0000	.0000	.0000	.0000	.0000	.0000	.0000	.0001
* -21.	.0000	.0000	.0000	.0000	.0000	.0000	.0000	.0000	.0000	.0001
* -22.	.0000	.0000	.0000	.0000	.0000	.0000	.0000	.0000	.0000	.0000

For  $\sigma = 0$ , Interference =  $1 - e^{-\gamma}$

STRESS DISTRIBUTION - NORMAL  
STRENGTH DISTRIBUTION - SMALLEST EXTREME VALUE

$\alpha = \beta\sigma, \gamma = \beta(\mu - M)$

$\gamma$	5.500	6.000	6.500	7.000	7.500	8.000	8.500	9.000	9.500	10.000
0.	.5399	.5369	.5342	.5319	.5299	.5281	.5265	.5251	.5238	.5227
-1.	.4693	.4719	.4740	.4759	.4775	.4789	.4802	.4813	.4822	.4831
-2.	.3997	.4077	.4145	.4204	.4255	.4300	.4340	.4376	.4408	.4437
-3.	.3332	.3459	.3568	.3664	.3748	.3822	.3888	.3947	.4001	.4049
-4.	.2717	.2880	.3023	.3149	.3261	.3361	.3451	.3531	.3604	.3670
-5.	.2164	.2352	.2519	.2669	.2803	.2924	.3033	.3132	.3221	.3303
-6.	.1683	.1882	.2064	.2229	.2379	.2515	.2639	.2753	.2857	.2952
-7.	.1278	.1476	.1661	.1833	.1992	.2139	.2274	.2398	.2513	.2620
-8.	.0945	.1133	.1313	.1485	.1646	.1797	.1939	.2070	.2193	.2307
-9.	.0682	.0851	.1019	.1184	.1342	.1493	.1636	.1771	.1898	.2017
-10.	.0480	.0625	.0776	.0929	.1079	.1225	.1365	.1500	.1628	.1750
-11.	.0329	.0450	.0580	.0717	.0855	.0992	.1127	.1258	.1385	.1506
-12.	.0219	.0316	.0426	.0544	.0668	.0794	.0920	.1045	.1167	.1286
-13.	.0142	.0217	.0306	.0406	.0514	.0627	.0743	.0860	.0975	.1090
-14.	.0090	.0146	.0216	.0298	.0390	.0489	.0593	.0700	.0808	.0916
-15.	.0056	.0096	.0149	.0215	.0292	.0377	.0468	.0564	.0663	.0763
-16.	.0033	.0062	.0101	.0153	.0215	.0286	.0365	.0450	.0539	.0631
-17.	.0019	.0039	.0067	.0107	.0156	.0215	.0281	.0355	.0434	.0517
-18.	.0011	.0024	.0044	.0073	.0111	.0159	.0214	.0277	.0346	.0421
-19.	.0006	.0014	.0028	.0049	.0078	.0116	.0161	.0214	.0274	.0339

(Continued on the next Table)

For  $\alpha = 0$ , Interference =  $1 - e^{-\gamma}$

STRESS DISTRIBUTION - NORMAL  
STRENGTH DISTRIBUTION - SMALLEST EXTREME VALUE

$\alpha = \beta\sigma, \gamma = \beta(\mu - M)$

Y	5.500	6.000	6.500	7.000	7.500	8.000	8.500	9.000	9.500	10.000
-20.	.0003	.0008	.0018	.0033	.0054	.0083	.0120	.0164	.0214	.0271
-21.	.0002	.0005	.0011	.0021	.0037	.0059	.0088	.0124	.0166	.0215
-22.	.0001	.0003	.0006	.0014	.0025	.0042	.0064	.0093	.0128	.0169
-23.	.0000	.0001	.0004	.0008	.0016	.0029	.0046	.0069	.0097	.0131
-24.	.0000	.0001	.0002	.0005	.0011	.0020	.0033	.0050	.0073	.0101
-25.	.0000	.0000	.0001	.0003	.0007	.0013	.0023	.0037	.0055	.0078
-26.	.0000	.0000	.0001	.0002	.0004	.0009	.0016	.0026	.0040	.0059
-27.	.0000	.0000	.0000	.0001	.0003	.0006	.0011	.0019	.0030	.0044
-28.	.0000	.0000	.0000	.0001	.0002	.0004	.0007	.0013	.0021	.0033
-29.	.0000	.0000	.0000	.0000	.0001	.0002	.0005	.0009	.0015	.0024
-30.	.0000	.0000	.0000	.0000	.0001	.0001	.0003	.0006	.0011	.0018
-31.	.0000	.0000	.0000	.0000	.0000	.0001	.0002	.0004	.0008	.0013
-32.	.0000	.0000	.0000	.0000	.0000	.0001	.0001	.0003	.0005	.0009
-33.	.0000	.0000	.0000	.0000	.0000	.0000	.0001	.0002	.0004	.0007
-34.	.0000	.0000	.0000	.0000	.0000	.0000	.0001	.0001	.0003	.0005
-35.	.0000	.0000	.0000	.0000	.0000	.0000	.0000	.0001	.0002	.0003
-36.	.0000	.0000	.0000	.0000	.0000	.0000	.0000	.0001	.0001	.0002
-37.	.0000	.0000	.0000	.0000	.0000	.0000	.0000	.0000	.0001	.0002
-38.	.0000	.0000	.0000	.0000	.0000	.0000	.0000	.0000	.0000	.0001
-39.	.0	.0000	.0000	.0000	.0000	.0000	.0000	.0000	.0000	.0001
-40.	.0	.0000	.0000	.0000	.0000	.0000	.0000	.0000	.0000	.0000

For  $\alpha = 0$ , Interference =  $1 - e^{-x}$

STRESS DISTRIBUTION - NORMAL  
 STRENGTH DISTRIBUTION - SMALLEST EXTREME VALUE

APPENDIX 3 EVALUATION OF THE INTEGRALS BY NUMERICAL ANALYSIS

## APPENDIX 3 EVALUATION OF THE INTEGRALS BY NUMERICAL ANALYSIS

## A-3.1 THE PROBLEM

In this report stress/strength interference theory was used to predict failure probabilities for several important cases not included in [1]. The two cases of interest here are (1) the smallest extreme value distributed strength and normally distributed stress and (2) the largest extreme value distributed strength and normally distributed stress. The integral

$$\Pr[\text{Failure}] = \Pr(X \leq Y) = \int_{-\infty}^{+\infty} F(y)g(y)dy \quad (1)$$

was evaluated where  $F(\cdot)$  is the distribution function of  $X$  (the random variable associated with the strength) and  $g(\cdot)$  is the density function of  $Y$  (the random variable associated with the stress). That is, we suppose that  $Y$  has a probability density function:

$$g_Y(y) = \frac{1}{\sqrt{2\pi}\sigma} e^{-\frac{1}{2}\left(\frac{y-\mu}{\sigma}\right)^2} dy, \quad -\infty \leq y \leq +\infty \quad (2)$$

and  $X$  has a probability distribution function

$$F_X(x) = 1 - e^{-e^{\beta(x-M)}}, \quad -\infty \leq x \leq +\infty \quad (3)$$

if it is distributed as the smallest extreme value. If  $X$  is distributed as the largest extreme value, its probability distribution function is:

$$F_X(x) = e^{-e^{-\beta(x-M)}}, \quad -\infty \leq x \leq +\infty \quad (4)$$

One sees that if  $z = 1 - F_X(x)$  is plotted on a  $\ln \ln$  scale it will be linearly related to  $x$  on an arithmetic scale as

$$z = \beta(x-M) \quad \text{or} \quad z = -\beta(x-M)$$

Hence one can call  $M$  the mode of the distribution and  $\beta$  (or  $-\beta$ ) the "slope" or "shape" parameter.

Inserting (2) and (3) or (4) into (1) will give (5) or (6).

$$\Pr(X \leq Y) = \int_{-\infty}^{+\infty} \left[ 1 - e^{-e^{\beta(y-M)}} \right] \frac{1}{\sqrt{2\pi}\sigma} e^{-\frac{(y-\mu)^2}{2\sigma^2}} dy \quad (5)$$



$$\Pr(X \leq Y) = \int_{-\infty}^{+\infty} \left[ e^{-e^{-\beta(y-M)}} \right] \frac{1}{\sqrt{2\pi}\sigma} e^{-\frac{(y-\mu)^2}{2\sigma^2}} dy \quad (6)$$

### A-3.2 SIMPLIFICATION OF THE EQUATIONS

Equations (5) and (6) are quite difficult to work with numerically since each one involves four parameters. It is desirable to define a new variable of integration and new parameters. To this end we let:

$$u = \frac{y-\mu}{\sigma}, \quad \alpha = \beta\sigma, \quad \text{and} \quad \gamma = \beta(\mu-M)$$

Then (5) of Section A-3.1 becomes

$$\Pr(X \leq Y) = \frac{1}{\sqrt{2\pi}} \int_{-\infty}^{+\infty} e^{-\frac{1}{2}\left(\frac{y-\mu}{\sigma}\right)^2} \frac{dy}{\sigma} - \frac{1}{\sqrt{2\pi}} \int_{-\infty}^{+\infty} e^{-e^{\beta(u\sigma+\mu-M)}} e^{-\frac{1}{2}\left(\frac{y-\mu}{\sigma}\right)^2} \frac{dy}{\sigma},$$

and this further reduces to

$$\Pr(X \leq Y) = 1 - \frac{1}{\sqrt{2\pi}} \int_{-\infty}^{+\infty} e^{-e^{\alpha u + \gamma}} e^{-\frac{1}{2}u^2} du \quad (7)$$

Also, (6) of Section A-3.1 becomes

$$\Pr(X \leq Y) = \frac{1}{\sqrt{2\pi}} \int_{-\infty}^{+\infty} e^{-e^{-(\alpha u + \gamma)}} e^{-\frac{1}{2}u^2} du \quad (8)$$

Inspection of (7) and (8) will show that the integral to be calculated is of the same form in each case except that the uppermost exponent is negative in the Largest Extreme Value case. Therefore, to further isolate the numerical analysis problem involved, define new constants A and G such that for (7), the Normal-Smallest Extreme Value integral,

$$A = \alpha \quad \text{and} \quad G = \gamma,$$

but for (8), the Normal-Largest Extreme Value integral,

$$A = -\alpha \quad \text{and} \quad G = -\gamma$$

Then, the calculation of the probabilities given by Equations (5) and (6) of Section A-3.1 reduces essentially to the integration of

$$\frac{1}{\sqrt{2\pi}} \int_{-\infty}^{+\infty} e^{-\frac{1}{2}u^2} e^{-e^{Au+G}} du \quad (9)$$

Since this integral does not exist in closed form, numerical techniques must be employed. The ranges of  $\alpha$  and  $\gamma$  of practical interest and the associated values of A and G are

$$A = \frac{1}{2}\alpha \text{ where } \alpha \text{ ranges: } .001, .005, .010, .025, .05, .075, .1, .2, \dots 3., \\ 3.5, \dots 9.5, 10$$

$$G = \frac{1}{2}\gamma \text{ where } \gamma \text{ ranges: } 0., -1., \dots -40$$

Note that  $\alpha$  itself is always positive and  $\gamma$  is always negative (or zero). A negative  $\alpha$  would imply a negative standard deviation. This situation is without mathematical meaning. If  $\gamma$  were positive, the material in question would have a mean strength less than the mode of the stress. Such a situation is of dubious engineering importance. ( $\beta$  is always positive.)

Note, also, that for the Normal-Smallest Extreme Value case, the probability of failure is one minus the number given by (9).

### A-3.3 NUMERICAL METHODS CONSIDERED FOR THE PROBLEM

The integral (9) of the previous section could be evaluated in several ways. Its form immediately suggests Gaussian-Hermite integration. This method can be summarized as follows:

$$\text{Let } F(u) = e^{-e^{Au+G}} \text{ and define } v = u/\sqrt{2},$$

$$\text{then } \frac{1}{\sqrt{2\pi}} \int_{-\infty}^{+\infty} e^{-\frac{1}{2}u^2} \cdot F(u) du = \frac{1}{\sqrt{\pi}} \int_{-\infty}^{+\infty} e^{-v^2} F(v) dv$$

and by the Gaussian-Hermite formulation,

$$\frac{1}{\sqrt{\pi}} \int_{-\infty}^{+\infty} e^{-v^2} F(v) dv = \frac{1}{\sqrt{\pi}} \sum_{i=1}^n A_i F(v_i)$$

where the arguments  $v_i$  are the zeros of the nth Hermite polynomial

$$H_n(v) = (-1)^n e^{v^2} \frac{d^n}{dv^n} (e^{-v^2})$$

and the coefficients  $A_i$  are

$$A_i = \frac{2^{n+1} n! \sqrt{\pi}}{[H'_n(v_i)]^2}$$

The numbers  $v_i$  and  $A_i$  are available in tables. The approximation error using this method depends on the higher derivatives of F. For the n-point case,

$$\text{error} = \frac{n! \sqrt{\pi} F^{(2n)}(\xi)}{2^n (2n)!}, \quad -\infty < \xi < +\infty$$

(The formula for computing the higher derivatives of F is given in Table A-3.1)

Errors in integrating (9) of Section A-3.2 were computed for the  $n = 2, 4,$  and  $8$  point formulas for the entire range of the parameters. It was found that the  $n = 8$  formulas would give acceptable errors for small  $|A|$  and large  $|G|$ . Theoretically at least, this scheme could be used to integrate (9) for any  $A$  and  $G$  if the number of points taken were sufficiently large.

Despite its advantages, the Gaussian-Hermite integration method was not used to prepare the tables of this report for the following reasons:

- i) The higher derivatives of  $F$  become quite difficult to compute and hence the errors involved are difficult to evaluate.
- ii) It proved useful for most values of the parameters for which the approach presented below proved even simpler.
- iii) It was decided that using only one method (that below) was more efficient than programming different methods for different values of  $A$  and  $G$ .

If users of the tables wish to compute probabilities of failure for  $\alpha$ 's and  $\gamma$ 's not included in this report, the Gaussian-Hermite method may prove acceptable, but the method employed here is recommended.

The tables of probabilities included in this report were generated by a FORTRAN program run on the University of Michigan's IBM 360/67. For every  $\alpha$  and  $\gamma$ , the program:

- i) Determined limits of integration following the logic of Section A-3.5,
- ii) Used Simpson's rule to integrate (9) within these limits, and
- iii) Added to the above value the integral of the normal curve neglected by using the calculated limits.

This approach is illustrated in Figure A-3.1. Its major advantages, which will be made clearer in later sections, can be listed as

- i) Automatically preventing computing difficulties by limiting the exponentials to be computed to acceptable values,
- ii) Having an easily computed error,
- iii) Reducing computing time by using the error function subroutine wherever possible and by automatically recognizing where the integral is approximately zero, and

DERIVATIVES OF  $e^{-e^{Au+G}}$

$$F = e^{-e^{Au+G}}, \quad P = -e^{Au+G}$$

$$F^{(1)} = A^1 F [P^1]$$

$$F^{(2)} = A^2 F [P^1 + P^2]$$

$$F^{(3)} = A^3 F [P^1 + 3 P^2 + P^3]$$

$$F^{(4)} = A^4 F [P^1 + 7 P^2 + 6 P^3 + P^4]$$

$$\vdots \quad \quad \quad \vdots \quad \quad \quad \vdots \quad \quad \quad \vdots \quad \quad \quad \vdots$$

$$F^{(n)} = A^n F [C_{1n} P^1 + C_{2n} P^2 + \dots C_{kn} P^k + \dots C_{nn} P^n]$$

If we let  $C_{(n+1)n} = 0$ , then the  $k$ th coefficient is given by

$$C_{kn} = k \cdot C_{k(n-1)} + C_{(k-1)(n-1)}$$

FOURTH DERIVATIVE OF  $e^{-\frac{1}{2}u^2 - e^{Au+G}}$

$$U = e^{-\frac{1}{2}u^2 - e^{Au+G}}, \quad F = e^{-e^{Au+G}}$$

$$U^{IV} = e^{-\frac{1}{2}u^2} \left[ (3-6u^2+u^4)F + (12u-4u^3)F^{(1)} + (-6+6u^2)F^{(2)} + (-4u)F^{(3)} + F^{(4)} \right]$$

$$U^{IV} = U \left\{ (3-6u^2+u^4) + \begin{array}{l} (-e^{Au+G})[A(12u-4u^3) + A^2(-6+6u^2) + A^3(-4u) + A^4] \\ (+e^{2(Au+G)})[A^2(-6+6u^2) + 3A^3(-4u) + 7A^4] \\ (-e^{3(Au+G)})[A^3(-4u) + 6A^4] \\ (+e^{4(Au+G)})[A^4] \end{array} \right\}$$

Table A-3.1 Expressions for  $U^{IV}$  and  $F^{(n)}$

Normal-Smallest Extreme Value

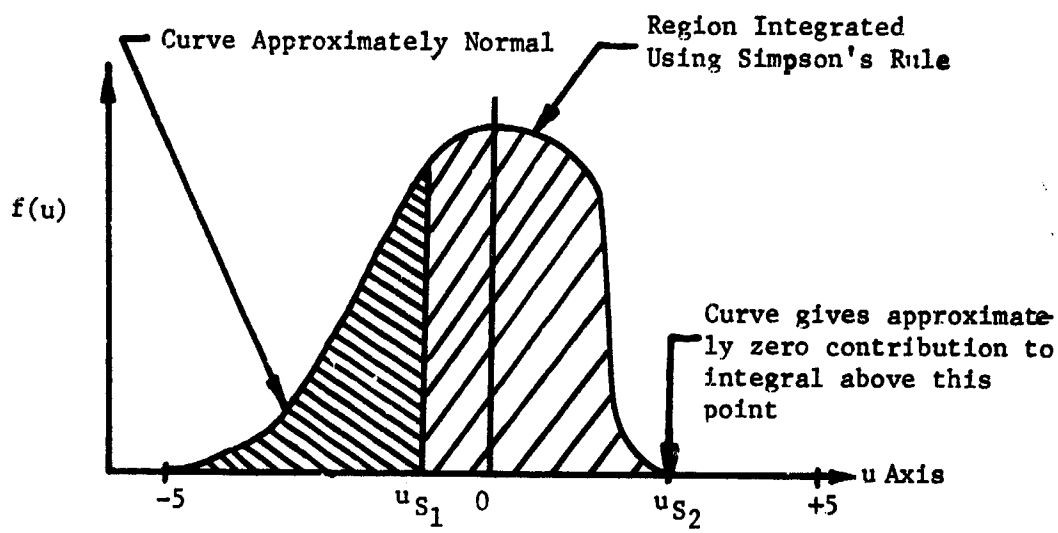

$PR(\text{Failure}) = 1. - (\text{total area under curve})$

Normal-Largest Extreme Value

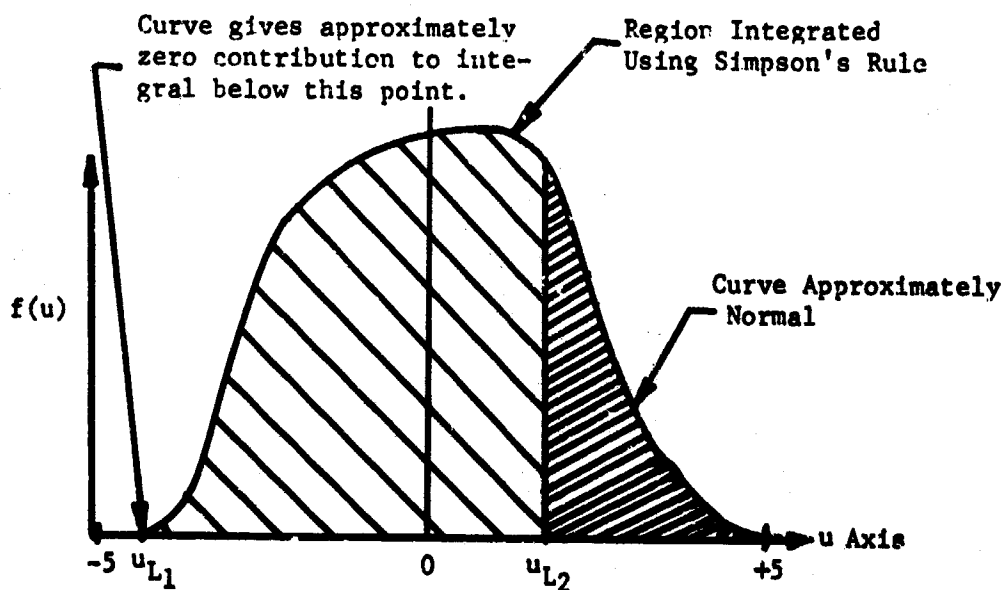

$PR(\text{Failure}) = (\text{Total area under curve})$

Figure A-3.1 Limits of Integration

- iv) Being applicable to any range of A and G simply by changing the Simpson's integration step-size.

#### A-3.4 SIMPLIFYING APPROXIMATIONS

The functions comprising the integrand of (9) of Section A-3.2 are quite well behaved and bounded between 0 and 1. Their exponential form leads to a number of important approximations. Let U equal the integrand of (9) and note that U is the product of the normal curve and a "double exponential."

The integral of the normal curve is equal to 1 within  $.5734 \times 10^{-6}$  over the interval -5 to +5. Therefore, since

$$0 \leq e^{-e^{Au+G}} \leq 1 \text{ implies } \left( \frac{1}{\sqrt{2\pi}} e^{-\frac{1}{2}u^2} \right) e^{-e^{Au+G}} \leq \left( \frac{1}{\sqrt{2\pi}} \cdot e^{-\frac{1}{2}u^2} \right),$$

$$\int_{-\infty}^{+\infty} Udu \approx \int_{-5}^{+5} Udu \quad \text{to at least 6 places.} \quad (10)$$

$$\text{Let } F = e^{-e^{Au+G}}$$

If the function F differs from one over some interval  $[u_1, u_2]$  by less than  $5 \times 10^{-5}$ , then the integral (10) can be evaluated to four places simply by integrating the normal curve (actually the FORTRAN error function subroutine was used). That is,

$$\int_{u_1}^{u_2} \left( \frac{1}{\sqrt{2\pi}} e^{-\frac{1}{2}u^2} \right) (1 - .00005) du \approx \int_{u_1}^{u_2} \frac{1}{\sqrt{2\pi}} e^{-\frac{1}{2}u^2} du \text{ where the}$$

$$\text{worst error} = .0005 \times \int_{-5}^{+5} \frac{1}{\sqrt{2\pi}} e^{-\frac{1}{2}u^2} du = .0005$$

The combination of u, A, and G which causes F to be within  $5 \times 10^{-5}$  of one is easily determined:

$$e^{-e^{Au+G}} > .99995$$

$$\text{for } e^{Au+G} < 5 \times 10^{-5}$$

$$\text{Take } e^{Au+G} < 1 \times 10^{-5}$$

$$\text{Then } \boxed{Au+G < -11.5} \quad (11)$$

If the function F differs from zero over the interval  $[-5, +5]$  by less than  $5 \times 10^{-5}$ , then the integral can be approximated as zero to four places. The above argument concerning the error applies here also; that is, the

integral differs from zero by less than  $5 \times 10^{-5}$  when  $F$  differs from zero by less than  $5 \times 10^{-5}$ . It will prove useful to know the value of the upper exponent for which this occurs.

$$e^{-e^{Au+G}} < .00005$$

$$\text{Take } e^{-e^{Au+G}} < 1 \times 10^{-5}$$

$$-e^{Au+G} < -11.5$$

$$Au+G > \ln 11.5$$

$$\boxed{Au+G > 2.44}$$

(12)

### A-3.5 LIMITS OF INTEGRATION

Equation (10) defined the limits of integration for our problem as  $-5$  to  $+5$ . The discussion below shows that it is possible to further isolate the interval on the  $u$ -axis in which numerical integration of (9) is necessary.

#### A-3.5.1 Limits for Normal-Smallest Extreme Value Case

For a given  $A$  and  $G$ , expression (11) defines a  $u$ -value, call it  $u_{s1}$ , below which the integrand can be approximated as a normal curve.

$$u_{s1} = \frac{-G-11.5}{A}$$

Likewise (12) defines a  $u$ , say  $u_{s2}$ , above which the contribution to the integral is zero.

$$u_{s2} = \frac{-G+2.44}{A}$$

Therefore, numerical integration need only be used on  $[u_{s1}, u_{s2}]$ . This is illustrated in Figure A-3.1. In some instances  $u_{s1}$  and  $u_{s2}$  may be outside the  $-5$  to  $+5$  limits established by (10). The limits should then be taken as  $-5$  to  $+5$ . Note that:

When  $u_{s1} > +5$  the integrand can be approximated to sufficient accuracy by considering it to be the normal density function.

When  $u_{s2} < -5$  the integrand can be approximated by considering it equal to zero.

#### A-3.5.2 Limits for Normal-Largest Extreme Value Case

The results of the previous article apply here directly except that for this case  $A = -\alpha$  (recall that  $\alpha$  is always positive) and the senses of both

(11) and (12) are reversed. This makes

$$u_{L1} = \frac{-G+2.44}{A}$$

and for  $u < u_{L1}$  the integral is "zero".

also, 
$$u_{L2} = \frac{-G-11.5}{A}$$

and for  $u > u_{L2}$  the curve is "normal".

When  $u_{L1} > +5$  the entire curve is "zero".

When  $u_{L2} < -5$  the entire curve is "normal".

Of course, in those situations where  $u_{L1} < -5$ , the lower limit should be taken as -5 and where  $u_{L2} > +5$ , the upper limit becomes +5.

#### A-3.6 DETERMINATION OF SIMPSON'S RULE STEP-SIZE

The truncation error for Simpson's integration scheme is given by

$$|\text{Error}| = \frac{(u_2 - u_1)}{180} U^{IV}(\xi)(\Delta u)^4, \quad u_1 \leq \xi \leq u_2. \quad (13)$$

The fourth derivative in this expression should be evaluated at the  $\xi$  which makes  $U^{IV}$  a maximum. The complexity of  $U^{IV}$  (shown in Table A-3.1) made a complete analysis of its behavior impossible. Study of the form of  $U^{IV}$  together with careful scrutiny of a large number of computed values gave what was believed to be good estimates for the maximum of  $U^{IV}$  for all combinations of A and G. These values were substituted into (13) and  $\Delta u$ 's were determined assuming a desired error of less than  $5 \times 10^{-5}$ .

Actually, only three  $\Delta u$ 's were used: .1, .05, and .01. Although the decision of which to use for a given set of the parameters was based upon inspection of calculated values of  $U^{IV}$ , an understanding of the behavior of  $U^{IV}_{\max}$  with changes in A and G is important. The double exponential coefficient of  $U^{IV}$  will damp out any influence by the other exponentials to make  $U^{IV}$  large. For  $A \rightarrow 0$ ,  $U^{IV}$  will be small. In fact, for A small,  $U^{IV}$  should behave similarly to the fourth derivative of the normal curve since G only acts as a "scaling factor" and does not effect the "curvature" of U. Tables show the fourth derivative of the normal curve to be approximately 1.

As  $A \rightarrow 0$ ,  $U^{IV}_{\max} \approx 1$ , and

$$|5 \times 10^{-5}| = \frac{[+5 - (-5)]}{180} (1)(\Delta u)^4$$

$$(\Delta u)^4 = 9 \times 10^{-4}$$

$$\Delta u \approx .17$$



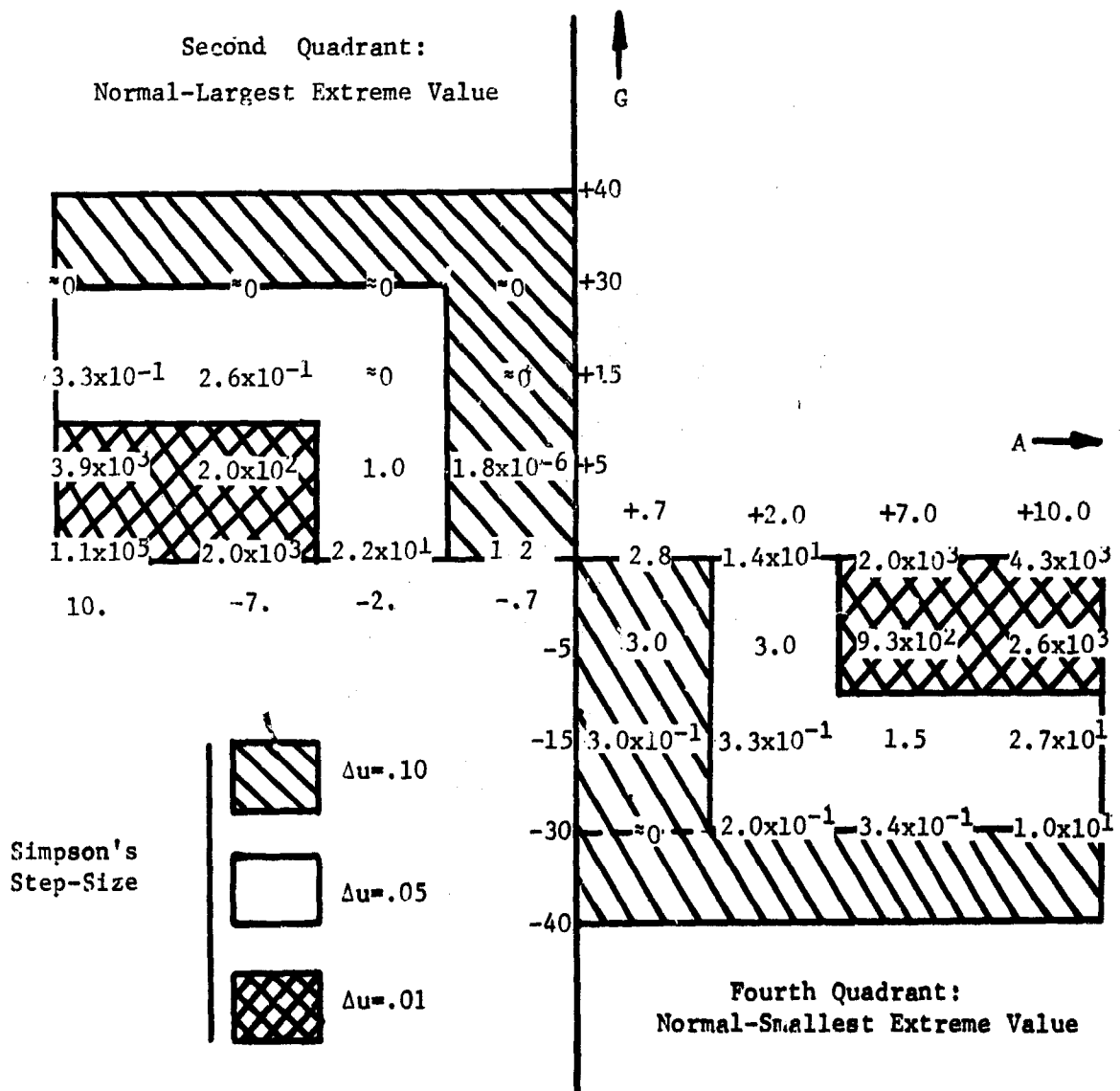

Note:  $U_{MAX}^{IV}$  is only given for the interval where Simpson's integration was used.

Figure A-3.2  $U_{MAX}^{IV}$  for Various A and G and Simpson's Integration Step-Size

For large  $|A|$ 's (neglect  $G$ ) the  $U^{IV}_{\max}$  will behave as  $A^4$ . Then for the largest  $A$  of interest,  $A = 10.0$ :

$$(\Delta u)^4 = \frac{9 \times 10^{-4}}{10^4} = 9 \times 10^{-8}$$

$$\Delta u \approx .0017 .$$

It can also be seen from the form of  $U^{IV}$  that for large  $|G|$ 's the value of  $U^{IV}$  will be driven to zero by one of the exponentials. (Note also that the behavior of  $U^{IV}$  is only of interest on that interval where Simpson's integration is to be used.)

Recall that for each of the two cases being studied and for each pair of the parameters  $\alpha$  and  $\gamma$ , the integration of (5) or (6) of A-3.1 requires use of Simpson's integration on an interval identified by Section A-3.5. The error produced by the use of Simpson's rule depends on the derivative  $U^{IV}$  and the fourth power of the step-size. Figure A-3.2 gives the value of  $U^{IV}_{\max}$  at various points in the A-G plane and shows the regions in the plane where the three step-sizes (.01, .05, and .1) could be used. In the A-G plane, the second quadrant is the region of interest for the Normal-Largest Extreme Value case ( $A = -\alpha$ ,  $.001 \leq \alpha \leq 10.$ ;  $G = -\gamma$ ,  $-40. \leq \gamma \leq 0$ ). The fourth quadrant is the A-G region of interest in the Normal-Smallest Extreme Value case. In Figure A-3.2, choose an abscissa and an ordinate; the number indicated is the maximum of  $U^{IV}$  found by calculating  $U$  for many  $u$ 's on the interval in which Simpson's rule was used. The cross-hatching defines the regions where the indicated step-size will maintain the error less than  $5 \times 10^{-5}$ . (These regions were delineated more carefully for the actual computer runs.)

#### Example:

Assume that we wish to find the probability of failure for the Normal Largest Extreme Value case for  $\alpha = .7$  and  $\gamma = -5$ . For this case, the parameters  $A$  and  $G$  in the integral (9) of A-3.2 become  $A = -\alpha = -.7$  and  $G = -\gamma = +5$ . Figure A-3.2 shows that for  $A = -.7$  and  $G = +5$ ,  $U^{IV}_{\max} \approx 2.0 \times 10^2$ . The cross-hatching shows that a step-size of  $\Delta u = .01$  is acceptable for the integration.

#### A-3.7 ERROR ANALYSIS

The possible errors produced in generating the tabulated values are listed below:

<u>Error Source</u>	<u>Maximum Error</u>
Truncation of integral on $[-5, +5]$	$-6 \times 10^{-7}$
Approximations of Section A-3.5	$-1 \times 10^{-5}$
Simpson's integration truncation	$\pm 5 \times 10^{-5}$
Computer round-off	$\pm 1 \times 10^{-7}$
Round-off to 4 places	$\pm 1 \times 10^{-4}$

The tabular values are correct to  $2 \times 10^{-4}$ .

#### A-3.8 SUMMARY

It was shown that calculation of the probabilities of failure reduces to the numerical evaluation of a single integral. The integral was computed by using Simpson's rule and by employing several approximations.

APPENDIX 4 FLOW CHART OF THE COMPUTER PROGRAM USED FOR  
DETERMINATION OF THE FATIGUE STRENGTH  
DISTRIBUTION

APPENDIX 4 FLOW CHART OF THE COMPUTER PROGRAM USED FOR THE DETERMINATION OF THE FATIGUE STRENGTH DISTRIBUTION

A-4.1 EXPLANATION OF THE SYMBOLS USED IN THE FLOW CHART

$C_1, C_2, C_3, \dots, C_1, \dots, C_m$  are the lives at which the distributions of fatigue strength are to be determined. In the present study, these are  $10^3, 10^4, 5 \times 10^4, 10^5, 5 \times 10^5, 10^6, 5 \times 10^6, 10^7, \text{ and } 10^8$  cycles.

$m$  is the total number of lives which in this study is equal to 9.

$U$  is the code number for a mode of stress, for example;

$U = 0$  is for the alternating (completely reversed) stress,

$U = 1$  is for the maximum stress,

$U = 2$  is for the range of stress (maximum-minimum).

$US$  is the identification number for the units of stress, for example;

$US = 1$  is for the units in psi,

$US = 2$  is for the units in ksi,

$US = 3$  is for the units in short tons/in<sup>2</sup>,

$US = 4$  is for the units in kilograms/mm<sup>2</sup>,

$US = 5$  is for the units in long tons/in<sup>2</sup>.

$UL$  is for the identification number for the units of life, for example;

$UL = 1$  is for the units in cycles,

$UL = 2$  is for the units in reversals (two reversals = one cycle),

$UL = 3$  is for the units in hours where frequency (cycles/hr) was known.

$S_m$  is the mean stress which in the present study was always equal to zero.

$S_1, S_2, S_3, \dots, S_1, \dots, S_m$  are the values of the applied stresses, and,

$L_1, L_2, L_3, \dots, L_1, \dots, L_m$  are the values of the life to failure corresponding to the above stresses.

$i$  is the subscript to designate the  $i$ th data point (for example,  $L_i$  and  $S_i$  are the coordinates of the  $i$ th data point of the S-N type data).

$n$  is the number of data points.

$MR_{n,1}, MR_{n,2}, \dots, MR_{n,n}$  are the median rank values for the sample size of  $n$  (for example,  $MR_{5,1}, MR_{5,2}, MR_{5,3}, MR_{5,4}, \text{ and } MR_{5,5}$  are the median rank values when  $n = 5$ ).

$Z_{n,1}, Z_{n,2}, Z_{n,3}, \dots, Z_{n,n}$  are the standardized normal variates corresponding to the median ranks of sample size  $n$ . (These are also called the median ranks  $z$  values as given in Table 6.1 on Page 49).

- $YW_i$  is the linear mode variable of the ordinate scale for Weibull distribution for the  $i$ th data point, and it is also the same for Smallest Extreme Value distribution (See Equations 6.24 and 6.25 on Pages 40 and 45).
- $YE_i$  is the linear mode variable of the ordinate scale for Largest Extreme Value distribution for the  $i$ th data point.
- $YL_i$  is the linear mode variable of the ordinate scale for Logistic distribution for the  $i^{\text{th}}$  data point.
- $YN_i$  is the linear mode variable of the ordinate scale for Normal distribution for the  $i$ th data point.
- $\alpha$  is the intercept of the least squares line on the Y-axis. (See Equation 6.3 in Section 6.1.1 on Page 28).
- $\alpha_N, \alpha_L, \alpha_M, \alpha_E,$  and  $\alpha_W$  are the intercepts of the least squares lines fitted to Normal, Logistic, Largest Extreme Value, Smallest Extreme Value and Weibull distributions respectively.
- $\beta$  is the slope of the least squares line. (See Equation 6.2 in Section 6.1.1 on Page 28.)
- $\beta_N, \beta_L, \beta_M, \beta_E,$  and  $\beta_W$  are the slopes of the least squares line fitted to Normal, Logistic, Largest Extreme Value, Smallest Extreme Value, and Weibull distribution respectively.
- $R$  is the correlation coefficient. (See Equation 6.6 in Section 6.1.3 on Page 29)
- $R_N, R_L, R_M, R_E,$  and  $R_W$  are the correlation coefficients of Normal, Logistic, Largest Extreme Value, Smallest Extreme Value, and Weibull distributions respectively.
- $IF$  is an identification number for each data set.
- $LC_j$  is the logarithm of life  $j$  at which the fatigue strength distribution is desired.
- $LST_{j,i}$  is the logarithm of fatigue strength at a given life  $j$  for a given data point  $i$ .
- $SN$  is the scatter of fatigue strength at a given life.
- $DEV$  is the standard deviation.
- $DX$  and  $DR$  are the differences between the two consecutive assumed values of  $X_0$  for the Weibull case.
- $ADX$  is the absolute value of  $DX$ .

DR is the difference between the two consecutive values of correlation coefficients corresponding to the two assumed values of  $X_0$  for the Weibull case.

#### A-4.2 EXPLANATION OF THE FLOW CHART.

The flow chart of the computer program used to determine the fatigue strength distribution was made up of three parts. In the first part of this program, the scatter in the life was converted into the scatter in the fatigue strength, and the y-ordinate of non-linear mode variables into the linear mode variables for each distribution (For example,  $P$  was converted to  $\ln \ln \frac{1}{1-P}$  for the Weibull case). In the second part, the distribution  $\frac{1}{1-P}$  functions (Weibull, Normal, Logistic, Largest Extreme Value and Smallest Extreme Value) were fitted to these strengths data simultaneously, and the one with the highest degree of fit was the best fitting distribution. The part three is an external Function Fit which was used in part one and part two to fit the least squares lines to the data. As shown in Section A-4.3, blocks were made around different sections of each of these three parts. The specific functions of each of these blocks in the total program are discussed in the following sections.

##### A-4.2.1 Part One - Conversion of Life Data to Strength Data and Non-Linear Mode Variables to Linear Mode Variables.

**Block 1:** The function of this block is to store all the necessary information and the various symbols used in this computer program. The program will be rejected in either case when number of data points ( $N$ ) is larger than 40 or number of lives ( $m$ ), at which the strength distribution is determined, is larger than 11. (See the flow chart in Section A-4.3).

**Block 2:** For some data, where the units of stress ( $US$ ) values are in tons/in<sup>2</sup>, killograms/in<sup>2</sup> etc., and the modes of stress ( $U$ ) in terms of range of stress, etc., these are converted to the units in psi and the mode of stress in completely reversed stress. This is done for each data point in a given data set.

**Block 3:** Non-linear mode of y co-ordinate of each data point (in this case the median rank value ( $P$ ) assigned to each data point) is converted into the linear mode of y co-ordinate (e.g.  $\ln \ln \frac{1}{1-P}$  for the Weibull case). This is done for all the four  $\frac{1}{1-P}$  distribution functions.

**Block 4:** In some data if the units of life are in terms of, say, hours or number of reversals, these are converted into cycles. This is done for each data point. The

values of stress and life are converted into the logarithm of stress ( $\log S$ ) and logarithm of life ( $\log N$ ).

Block 5: Using the External Function Fit (as discussed in Section A-4.2.3 and the flow chart shown in A-4.3.3) 1 least squares line ( $Y = \alpha + \beta X$ ) is fitted through these data points  $\log (S)$  and  $\log (N)$  found in Block 4, and the values of  $\alpha$  and  $\beta$  is determined in terms of  $\log \alpha$  and  $\log \beta$ .

Block 6: Using the values of  $\alpha$  and  $\beta$  as found by Block 5, and the procedure as discussed in Section 6.2, page 31, the scatter in strength in terms of logarithm of strength ( $LST_{j,i}$ ) at a given life  $j$  is determined.

#### A-4.2.2 Part Two - Determination of the Best Fitting Distribution.

Block 7: The values of logarithm of strengths [ $\log (s)$ ] at a given life (as found in Block 6) are arranged in an increasing order, and they are then converted from  $\log (S)$  to  $S$ .

Block 8: Using the strength values as found from Block 7 and the information from Block 3, the distributions such as Normal, Logistic, Largest Extreme Value and Smallest Extreme Value are fitted (as discussed in Section 6.5) by aid of the External Function Fit discussed in Section A-4.2.3. The values of the correlation coefficients,  $R$ , for each of these distribution are then computed.

Block 9: As discussed in Section 6.5.1 (on Weibull distribution,) it is necessary to determine the value of  $\bar{X}_0$ , the lower bound of strength, before fitting the Weibull distribution to the data. In this block, the initial value of  $\bar{X}_0$  is assumed in the manner shown.

Block 10: Other values of  $X_0$  subsequent to the one assumed in Block 9 are assumed, and the magnitude of the new values of  $\bar{X}_0$  depends on the magnitude of the previous ones, as shown in this block.

Block 11: Once a value of  $\bar{X}_0$  is assumed, the values of  $\bar{X}_1 = \ln (x_1 - \bar{X}_0) = \ln (SN_1 - \bar{X}_0)$  are found. Using the value of  $\bar{X}_1$  and  $YW_1$  (as found from Block 3). The Weibull distribution is fitted to these data by External Function Fit and the corresponding values of the parameters  $\alpha$  and  $\beta$  of the least squares line ( $Y = \alpha + \beta X$ ) and the correlation coefficient,  $R$ , are computed. This is



repeated twelve times and twelve values of  $\bar{X}_0$  and their corresponding values of  $\alpha$ ,  $\beta$ , and  $R$  are computed. (Note: The number of repetitions, twelve, was chosen arbitrarily).

Block 12: Out of these twelve values of the correlation coefficients which has the maximum value (the best fit) is selected, and its corresponding value of  $\bar{X}_0$  is taken as the "true" value of the lower bound of strength  $\bar{X}_0$ .

Block 13: The fatigue strength distributions (such as, Weibull, Normal, Logistic, Largest Extreme Value and Smallest Extreme Value), the values of their parameters (in units of KSi where appropriate) and their corresponding values of correlation coefficients are printed out. From this information computer also prints out the name of the best fitting distribution.

#### A-4.2.3 Part Three - External Function Fit

Block 14: External Function Fit is used in Part-one and Part-two of the flow chart to fit a least squares line ( $Y = \alpha + \beta\bar{X}$ ) to a set of data points where the values of  $\alpha$  and  $\beta$  are computed using Equations (6.2) and (6.3) given on page 28. The corresponding value of the correlation coefficient is then calculated using equations (6.6), (6.7), and (6.8) as given on page 29.

A - 4.3 THE FLOW CHART

A-4.3.1 Part One

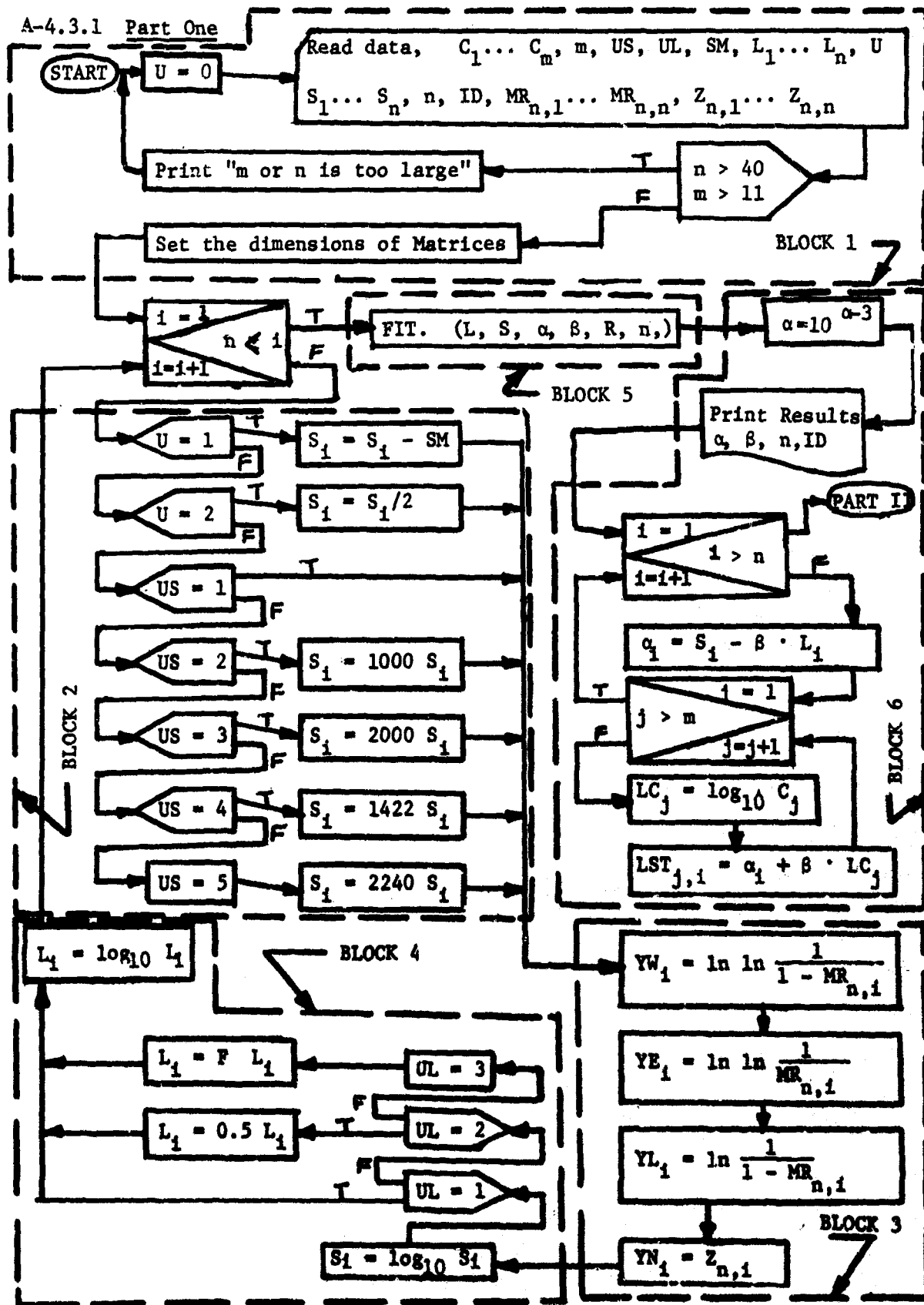

A-4.3.2 Part Two

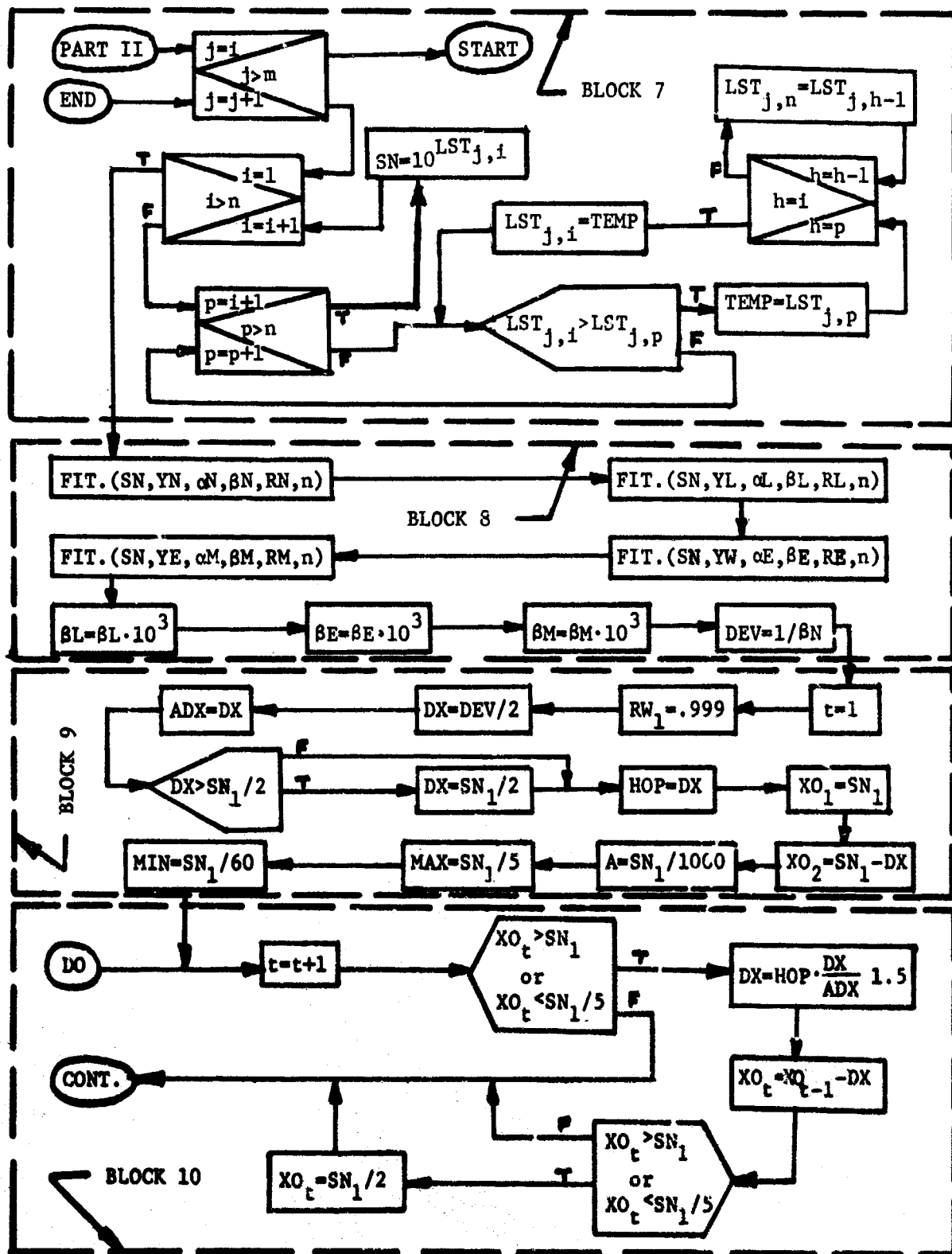

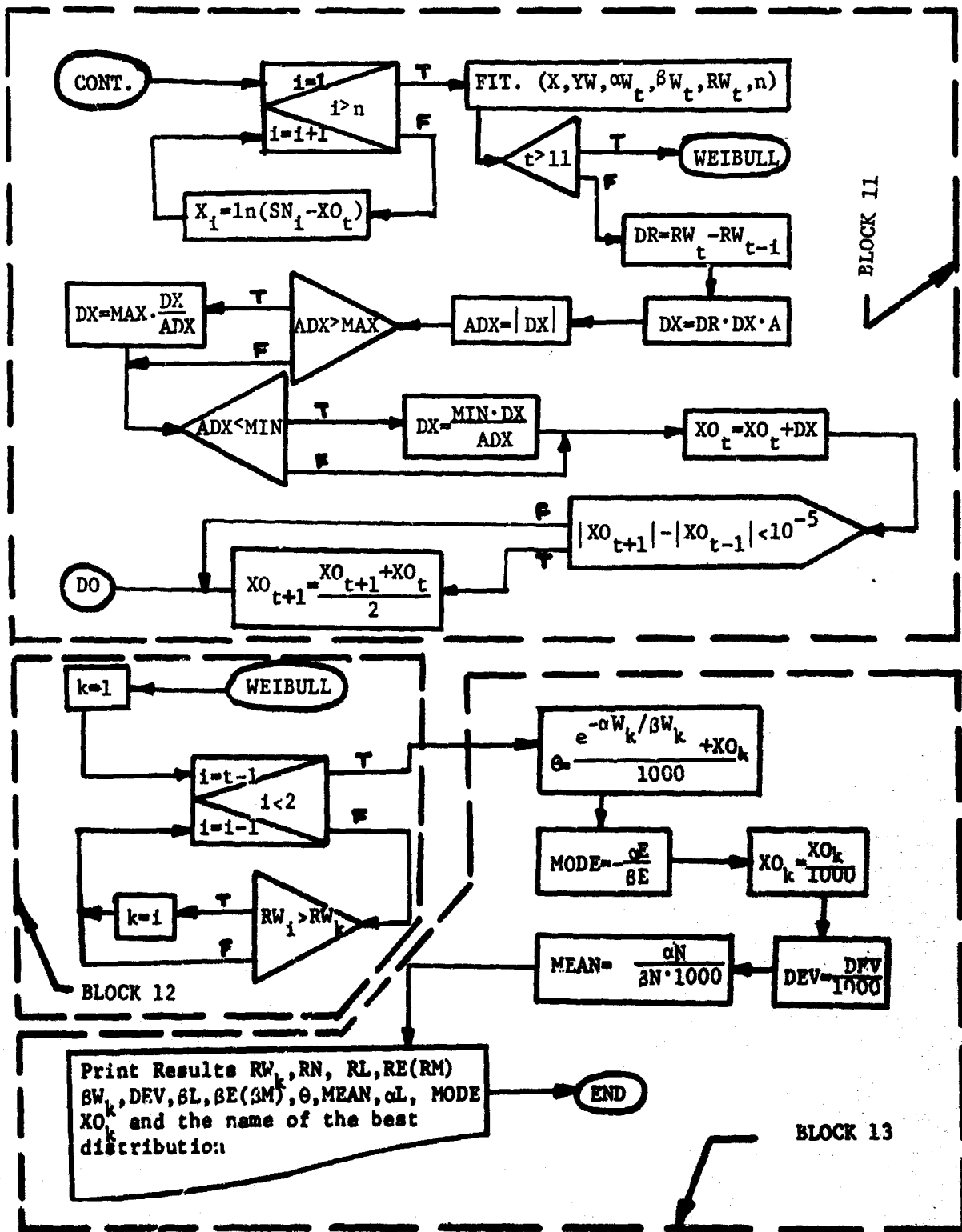

A-4.3.3 External Function Fit

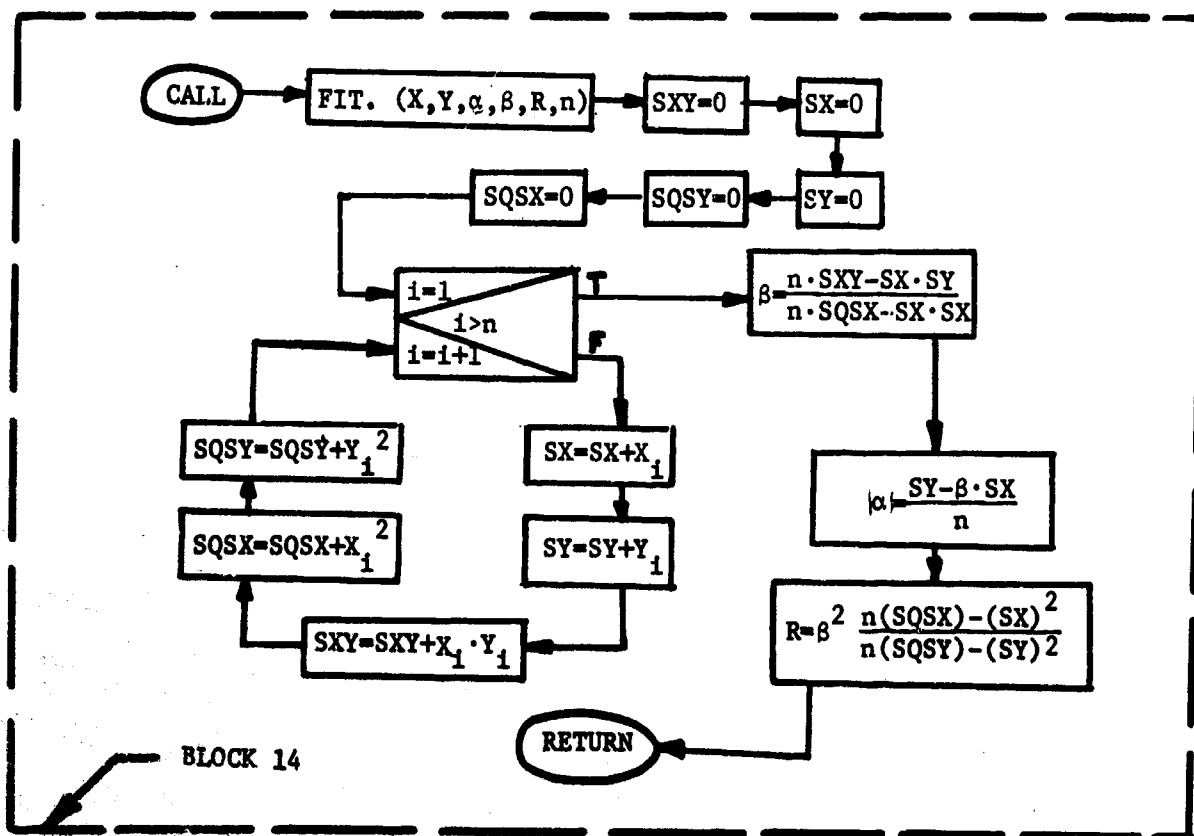

UNCLASSIFIED

Security Classification

DOCUMENT CONTROL DATA - R & D		
<i>(Security classification of title, body of abstract and indexing annotation must be entered when the overall report is classified)</i>		
1. ORIGINATING ACTIVITY (Corporate author) University of Michigan Ann Arbor MI 48104		2a. REPORT SECURITY CLASSIFICATION UNCL
		2b. GROUP N/A
2. REPORT TITLE Reliability Prediction-Mechanical Stress/Strength Interference (Nonferrous)		
4. DESCRIPTIVE NOTES (Type of report and inclusive dates) Final Report - March 1967 - August 1968		
3. AUTHOR(S) (First name, middle initial, last name) Charles Lipson                      Ralph C. Disney Narendra J. Sheth                  Mehmet Altun		
6. REPORT DATE February 1969	7a. TOTAL NO. OF PAGES 450	7b. NO. OF REFS 16
5a. CONTRACT OR GRANT NO. F30602-67-C-0204	5b. ORIGINATOR'S REPORT NUMBER(S)	
5c. PROJECT NO. 5519		
5d. Task No. 551902	5d. OTHER REPORT NO(S) (Any other numbers that may be assigned this report) RADC-TR-68-403	
10. DISTRIBUTION STATEMENT This document is subject to special export controls and each transmittal to foreign governments, foreign nationals, or representatives thereto may be made only with prior approval of RADC (EMERR), GAFB, NY 13440.		
11. SUPPLEMENTARY NOTES Donald W. Fulton - Project Engineer	12. SPONSORING MILITARY ACTIVITY Rome Air Development Center (EMERR) Griffiss AFB NY 13440	
13. ABSTRACT - This study was addressed to the development of a practical engineering tool based on the stress/strength interference theory to be used for designing and predicting the reliability of nonferrous material parts subjected to fatigue loading. Fatigue data was gathered for 111 nonferrous materials which was converted to strength data to obtain the scatter of strength at a given life. A computer program was used to determine the distribution of the data (i.e., Weibull, Normal, Logistic, LEV and SEV). The required stress distribution is obtained by converting the stress spectrum, known or assumed, to a zero mean stress spectrum using the Goodman diagram. The required stress spectrum, expressed in terms of equivalent stress, is obtained using Miner's rule. In this study the interference of two distributions is expressed as an integral which was evaluated using an IBM Computer 360. Tabular values are given for Normal/Weibull, Normal/Largest Extreme Value and Normal/Smallest Extreme Value distributions. In order to illustrate the application of the interference technique two examples are presented and solved.		

DD FORM 1473  
1 NOV 65

UNCLASSIFIED

Security Classification

**UNCLASSIFIED**

Security Classification

14. KEY WORDS	LINK A		LINK B		LINK C	
	ROLE	WT	ROLE	WT	ROLE	WT
Reliability Distribution						
Mechanical Components						
Stress/Strength Interference						
Fatigue						

**UNCLASSIFIED**

Security Classification