

AFWAL-TR-84-4123



AN OVERVIEW OF THE MIL-HDBK-5 PROGRAM

PAUL E. RUFF
BATTELLE COLUMBUS LABORATORIES
505 KING AVENUE
COLUMBUS, OHIO 43201-2693

SEPTEMBER 1984

FINAL REPORT FOR PERIOD 9 JUNE 1980—2 JULY 1984

20000804070

Approved for public release; distribution unlimited.

Reproduced From
Best Available Copy

DTIC
ELECTE
NOV 16 1984
E

MATERIALS LABORATORY
AIR FORCE WRIGHT AERONAUTICAL LABORATORIES
AIR FORCE SYSTEMS COMMAND
WRIGHT-PATTERSON AIR FORCE BASE, OHIO 45433

84 11 05 111

AD-A147 760
DTIC FILE COPY

NOTICE

When Government drawings, specifications, or other data are used for any purpose other than in connection with a definitely related Government procurement operation, the United States Government thereby incurs no responsibility nor any obligation whatsoever; and the fact that the Government may have formulated, furnished, or in any way supplied the said drawings, specifications, or other data, is not to be regarded by implication or otherwise as in any manner licensing the holder or any other person or corporation, or conveying any rights or permission to manufacture, use, or sell any patented invention that may in any way be related thereto.

This report has been reviewed by the Office of Public Affairs (ASD/PA) and is releasable to the National Technical Information Service (NTIS). At NTIS, it will be available to the general public, including foreign nations.

This technical report has been reviewed and is approved for publication.



C. L. Harmsworth, Technical Manager
for Engineering and Design Data
Materials Engineering Branch
Systems Support Division
Air Force Wright Aeronautical Laboratory

FOR THE COMMANDER

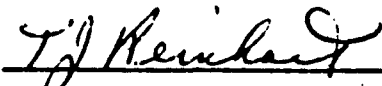

T. G. Reinhart, Chief
Materials Engineering Branch
Systems Support Division;
Air Force Wright Aeronautical Laboratory

If your address has changed, if you wish to be removed from our mailing list, or if the addressee is no longer employed by your organization, please notify AFWAL/MLSA, WPAFB, OH 45433, to help us maintain a current mailing list.

Copies of this report should not be returned unless return is required by security considerations, contractual obligations, or notice on a special document.

Unclassified

SECURITY CLASSIFICATION OF THIS PAGE (When Data Entered)

REPORT DOCUMENTATION PAGE		READ INSTRUCTIONS BEFORE COMPLETING FORM
1. REPORT NUMBER AFWAL-TR-84-1423	2. GOVT ACCESSION I.O. A147788	3. RECIPIENT'S CATALOG NUMBER
4. TITLE (and Subtitle) AN OVERVIEW OF THE MIL-HDBK-5 PROGRAM	5. TYPE OF REPORT & PERIOD COVERED Final, June 9, 1980- July 2, 1984	
	6. PERFORMING ORG. REPORT NUMBER	
7. AUTHOR(s) Paul E. Ruff	8. CONTRACT OR GRANT NUMBER(s) F33615-80-5037	
9. PERFORMING ORGANIZATION NAME AND ADDRESS Battelle's Columbus Laboratories 505 King Avenue Columbus, Ohio 43201	10. PROGRAM ELEMENT, PROJECT, TASK AREA & WORK UNIT NUMBERS 2418/01/21	
11. CONTROLLING OFFICE NAME AND ADDRESS Materials Lab, Air Force Wright Aeronautical Lab Air Force Systems Command Wright-Patterson Air Force Base, Ohio 45433	12. REPORT DATE September 1984	
	13. NUMBER OF PAGES 46	
14. MONITORING AGENCY NAME & ADDRESS (if different from Controlling Office) DCASMA, Dayton Defense Electronics Supply Center Building 5, 1502 Wilmington Pike Dayton, Ohio 45444	15. SECURITY CLASS. (of this report) Unclassified	
	15a. DECLASSIFICATION/DOWNGRADING SCHEDULE	
16. DISTRIBUTION STATEMENT (of this Report) Approved for public release; distribution unlimited.		
17. DISTRIBUTION STATEMENT (of the abstract entered in Block 20, if different from Report)		
18. SUPPLEMENTARY NOTES		
19. KEY WORDS (Continue on reverse side if necessary and identify by block number) tensile yield strength bearing yield strength tensile ultimate strength bearing ultimate strength compressive yield strength design allowables shear ultimate strength		
20. ABSTRACT (Continue on reverse side if necessary and identify by block number) This final report presents an overview of the MIL-HDBK-5 program including the history of the MIL-HDBK-5 Handbook. A test program to determine MIL-HDBK-5 design allowable properties for 17-4PH (H1000) casting is also described.		

DD FORM 1473
1 JAN 73

EDITION OF 1 NOV 65 IS OBSOLETE

Unclassified

SECURITY CLASSIFICATION OF THIS PAGE (When Data Entered)

PREFACE

This final report was submitted by Battelle's Columbus Laboratories, 505 King Avenue, Columbus, Ohio 43201, under Contract F33615-80-C-5037 with the Air Force Wright Aeronautical Laboratory, Wright-Patterson Air Force Base, Ohio. Mr. C. L. Harmsworth (MLSE) was the laboratory project monitor. This report covers the period June 9, 1980, through July 2, 1984. This report was submitted by the author, Mr. Paul E. Ruff, in July, 1984.

Accession For	
NTIS GRA&I	<input checked="" type="checkbox"/>
DTIC TAB	<input type="checkbox"/>
Unannounced	<input type="checkbox"/>
Justification	
By	
Distribution/	
Availability Codes	
Dist	Avail and/or Special
A-1	



TABLE OF CONTENTS

	<u>Page</u>
INTRODUCTION	1
DESCRIPTION OF MIL-HDBK-5	1
MODE OF OPERATION	2
DATA ACQUISITION AND ANALYSES	4
HISTORY	6
APPENDIX A	14
APPENDIX B	18
APPENDIX C	21



LIST OF SYMBOLS

R	=	reduced ratio
\bar{r}	=	mean value of ratios
s	=	standard deviation
$t_{0.95}$	=	the 0.95 fractile of the t distribution corresponding to n-1 degrees of freedom
n	=	number of ratios in sample or Ramberg-Osgood shape parameter for stress-strain curve
F_{tu}	=	ultimate tensile stress (design allowable)
F_{ty}	=	tensile yield stress (design allowable)
F_{cy}	=	compressive yield stress (design allowable)
F_{su}	=	ultimate shear stress (design allowable)
F_{bru}	=	ultimate bearing stress (design allowable)
F_{bry}	=	bearing yield stress (design allowable)
E	=	modulus of elasticity in tension
E_c	=	modulus of elasticity in compression
G	=	modulus of rigidity
TUS	=	tensile ultimate strength
TYS	=	tensile yield strength
CYS	=	compressive yield strength
SUS	=	shear ultimate strength
BUS	=	bearing ultimate strength
BYS	=	bearing yield strength
ksi	=	thousands of pounds per square inch
RA	=	reduction of area
e	=	elongation
μ	=	Poisson's ratio
e/D	=	ratio of edge distance to hole diameter (bearing strength)
C	=	specific heat
k	=	thermal conductivity
α	=	coefficient of thermal expansion
ω	=	density

SUMMARY

An overview of the MIL-HDBK-5 program is presented. The intent of the overview is to provide information which will be helpful to those who are not familiar with the MIL-HDBK-5 program. In addition, the history of the MIL-HDBK-5 Handbook and its predecessor, ANC-5 Bulletin, has been chronicled for the first time.

MIL-HDBK-5, "Metallic Materials and Elements for Aerospace Structures", contains standardized mechanical property design values and other related design information for metallic materials, fasteners and joints, as well as other structural elements used in aircraft, missiles, and space vehicles. The mechanical property design allowables are presented on a statistical or specification basis. Data for other properties are typical. The products included in the document are standardized with regard to composition and processing methods and are described by industry or government specifications. In addition, the Handbook contains some of the more commonly used methods and formulas by which the strength of various structural elements are calculated. The last chapter of the document contains guidelines for the analysis and presentation of data for MIL-HDBK-5. Department of Defense agencies, Federal Aviation Administration (FAA) and National Aeronautics and Space Administration require the use of data in this Handbook in the design of aerospace vehicles which are purchased or controlled by them.

Although the Air Force has the responsibility for maintaining and updating MIL-HDBK-5, the Handbook is maintained as a joint effort of the Air Force, Army, Navy, and FAA. The Air Force contracts with Battelle's Columbus Laboratories to provide many of the services required to maintain and update MIL-HDBK-5. Funding for the MIL-HDBK-5 program is currently provided by the Air Force, Army Materials and Mechanics Research Center, and FAA.

Biannual MIL-HDBK-5 government/industry coordination meetings are usually held in April and October. Representatives from governmental agencies, aerospace industry, metallic material suppliers, and fastener manufacturers attend these meetings. There is no formal membership. Currently, Mr. C. L. Harmsworth, Materials Laboratory, Air Force Wright Aeronautical Laboratories (AFWAL), chairs the MIL-HDBK-5 Coordination Group. The purpose

of these meetings is to consider and take action on proposed changes and additions to MIL-HDBK-5. Proposed modifications are normally attached to the agenda for the meeting and presented orally at the meeting. The meeting also provides the opportunity for anyone to propose or request changes to the Handbook. Various task groups, appointed by the Chairman, are utilized to study specific problems and make recommendations to the MIL-HDBK-5 Coordination Group. The additions and changes to MIL-HDBK-5 which are approved at the coordination meetings are prepared by the Air Force contractor in the form of a typeset, camera-ready copy suitable for printing by the Naval Publications and Forms Center.

Revisions of MIL-HDBK-5 are published, for the most part, annually. Normally, three change notices (partial) revisions are issued followed by a complete reissue. The Handbook is available from the Naval Publications and Forms Center, 5801 Tabor Avenue, Philadelphia, Pennsylvania 19120. Up to ten copies will be supplied to government contractors at no cost.

A detailed description of the data acquisition process, analytical techniques, and procedures for incorporating a new material or fastener into MIL-HDBK-5 is included. As an example, a design allowable test program, conducted on this contract, for 17-4PH (H1000) castings is described in detail in Appendix C.

INTRODUCTION

The ANC-5 Bulletin, the predecessor to MIL-HDBK-5, was originally conceived in the late 1930's to standardize the requirements of various government agencies in the design of aircraft structure. As design concepts and structural materials have evolved, there have also been evolutionary changes in analysis procedures, presentation methods, the approval process for changes and additions, and, of course, in the Handbook itself. While the final reports for previous MIL-HDBK-5 contracts and interim reports, such as reference (1), have described in detail the technical activities performed to maintain and update the document, an overview of the MIL-HDBK-5 program has not been previously published. Such an overview is desirable, specifically to inform new participants about the approval process, as well as to orient them to the overall MIL-HDBK-5 program. In addition, inquiries are continuously received concerning the procedure to be followed in generating data suitable for the determination of design allowables and the data required to incorporate new material into MIL-HDBK-5. The intent of this overview is to provide information which will be helpful to those people who are not familiar with the MIL-HDBK-5 program.

A description of MIL-HDBK-5 and the mode of operation for the MIL-HDBK-5 program has been included in this overview. The data acquisition procedures and the analytical procedures have been described. A report on a design allowable test program for 17-4PH (H1000) castings has been attached as Appendix C. In addition, historical background on the MIL-HDBK-5 program has been incorporated.

DESCRIPTION OF MIL-HDBK-5

Since many aerospace companies manufacture both commercial and military products, the standardization of metallic materials design data which

(1) Rice, Richard, "Reference Document for Analysis of Creep and Stress-Rupture Data in MIL-HDBK-5", AFWAL-TR-81-4097, Battelle's Columbus Laboratories, September 1981.

are acceptable to government procuring or certification agencies is very beneficial to those manufacturers as well as governmental agencies. Although the design requirements for military and commercial products may differ greatly, the design values for the strength of materials and elements or other needed material characteristics are often identical. Therefore, Military Handbook MIL-HDBK-5, "Metallic Materials and Elements for Aerospace Structures", contains standardized mechanical property design values and other related design information for metallic materials, fasteners and joints, as well as other structural elements used in aircraft, missiles, and space vehicles. The Handbook lists the minimum strength values for those mechanical properties which are widely used in the design of aerospace structures. Information and data for other properties and characteristics, such as fracture toughness strength, fatigue strength, creep strength, rupture strength, crack growth rate, and resistance to stress corrosion are also included. The mechanical property design allowables are presented on a statistical or specification basis. Data for other properties are typical. The products included in this document are standardized with regard to composition and processing methods and are described by industry or government specifications. In addition, the Handbook contains some of the more commonly used methods and formulas by which the strengths of various structural elements or components are calculated. The last chapter of the document contains the guidelines for the analysis and presentation of data for MIL-HDBK-5. Department of Defense agencies, Federal Aviation Administration (FAA), and National Aeronautics and Space Administration require the use of the data on this Handbook in the design of aerospace vehicles which are purchased or controlled by them.

MODE OF OPERATION

The Air Force has been assigned the responsibility for maintaining and updating MIL-HDBK-5. However, the Handbook is maintained as a joint effort of the Air Force, Army, Navy, and FAA. The Air Force contracts with Battelle's Columbus Laboratories to provide all of the services required to maintain and update MIL-HDBK-5. The Air Force contractor (1) assesses the

design allowable data requirements of the aerospace industry, (2) collects needed data, (3) processes, computerizes, and stores collected data for analysis, (4) statistically analyzes data to determine minimum or typical design values, (5) prepares reports containing proposed additions and changes to MIL-HDBK-5, (6) participates in the biannual MIL-HDBK-5 government/industry coordination meetings by arranging for meetings, preparing the agenda for the meetings, and giving oral presentations of proposed additions and changes, as well as preparing the minutes of the meetings, and (7) prepares typeset, camera-ready copy (suitable for printing) of the MIL-HDBK-5 revisions. Funding for the MIL-HDBK-5 program is currently provided by the Air Force, Army Materials and Mechanics Research Center, and FAA.

Biannual MIL-HDBK-5 government/industry coordination meetings are usually held in April and October. Representatives from governmental agencies, aerospace industry, metallic material suppliers, and fastener manufacturers attend these meetings. There is no formal membership and the activity is best described as a government/industry coordination group rather than a committee. The current chairman of the MIL-HDBK-5 Coordination Group is Mr. C. L. Harnisworth, Materials Laboratory, Air Force Wright Aeronautical Laboratories (AFWAL). The purpose of these meetings is to consider and approve proposed changes and additions to MIL-HDBK-5. Proposed modifications are normally attached to the agenda for the meeting and presented orally at the meeting. The meeting also provides the opportunity for anyone to propose or request changes to the document.

The Chairman appoints task groups to study specific problems and to make recommendations to the MIL-HDBK-5 Coordination Group. Currently, there are two MIL-HDBK-5 task groups. The Fastener Task Group, which functions continuously, reviews proposals by fastener manufacturers for the incorporation of design values for fastener systems into MIL-HDBK-5 and makes recommendations to the Coordination Group concerning changes and additions to Chapter 8 (fasteners) and Chapter 9 (guidelines). The objective of the Elevated Temperature Task Group, which has been operating for eight years, is to delineate the type of properties that engine manufacturers and other aerospace companies concerned with high-temperature applications would like included in MIL-HDBK-5, to determine the analytical methods to be used to

analyze such data, and to prepare guidelines specifying the analytical procedures and the methods of presenting such data in MIL-HDBK-5. The objective of the Aluminum Casting Task Group, recently disbanded in May 1984, was to incorporate statistically based design allowables for at least one high-strength, premium-quality, aluminum casting alloy into MIL-HDBK-5. These task groups provide invaluable service to the MIL-HDBK-5 program.

The additions and changes to MIL-HDBK-5 which are approved at the coordination meetings are prepared by the Air Force contractor in the form of a typeset, camera-ready copy suitable for printing by the Naval Publications and Forms Center.

Revisions of MIL-HDBK-5 are published, for the most part, annually. Normally, three change notices (partial) revisions are issued followed by a complete reissue. The Handbook is available from the Naval Publications and Forms Center, 5801 Tabor Avenue, Philadelphia, Pennsylvania 19120. Up to ten copies will be supplied to government contractors at no cost.

DATA ACQUISITION AND ANALYSES

Because of the importance of the data acquisition and data analysis functions in maintaining MIL-HDBK-5, these activities are described in more detail. A critical part of the MIL-HDBK-5 program is the collection of needed data. Aerospace companies and material suppliers provide a considerable amount of data. Tensile yield and ultimate strength design values are determined on a statistical basis. Consequently, large quantities of test values from many different heats or lots from products of different sizes are required. Metallic material suppliers routinely conduct tensile tests on production material, as part of their quality control procedures to determine conformance to the specified material specification. Most material suppliers cooperate in supplying this tensile property data for the determination of statistically based design values for MIL-HDBK-5. Much data, especially fatigue and creep data, are obtained from the open literature. An important source of data, available from published literature, is the Metals and Ceramics Information Center, which collects data for metallic materials. Another

important data source is the MIL-HDBK-5 files which are maintained by the Air Force contractor. These files contain various types of data (some unpublished) which have been supplied for exclusive use on the MIL-HDBK-5 program.

For new products it is usually necessary to conduct a test program to obtain the required mechanical property data and other information required to incorporate a new material into MIL-HDBK-5. In many instances, the company which developed and markets the material conducts the test program to obtain the required mechanical property data for the determination of design allowables. In the past, the Air Force contractor, for the MIL-HDBK-5 program, has conducted design allowable test programs to obtain needed data. Battelle executed such a test program, which is described in Appendix C, on this contract for 17-4PH (H1000) castings. In other cases, when design values for certain properties were missing from MIL-HDBK-5, the Materials Laboratory, AFWAL, has performed limited test programs to acquire needed data. The Materials Laboratory, AFWAL, is currently sponsoring a research program, "Manufacturing Technology Effects of Manufacturing Processes on Structural Allowables". This program, which is performed by an Air Force contractor, generates mechanical property and fatigue data suitable for the determination of design values for MIL-HDBK-5. The fastener company which developed and/or markets the fastener normally supplies the test data for a new fastener. Section 9.4.1.4.3 of Chapter 9 in MIL-HDBK-5 requires that 75 percent of assembled joint strength data be generated by one source and 25 percent from another source. In some instances, fastener data have been generated by aerospace companies, usually under government contract.

Section 9.1.6 of MIL-HDBK-5 specifies the data requirements for a new material. This section has been excerpted from MIL-HDBK-5 and is attached as Appendix B. Chapter 9 also contains the requirements for elevated temperature, fatigue, crack growth, fracture toughness, and creep-rupture data. Section 9.4.1 of MIL-HDBK-5 delineates the data requirements for a new fastener system. After the approval of static joint strength allowables for incorporation into MIL-HDBK-5, the fastener manufacturer must provide forty samples of the fastener, from the same production lot as that used in the test program, to the Chairman of the MIL-HDBK-5 Coordination Group as specified in Section 9.4.1.7.3 of MIL-HDBK-5.

Certain procedures must be followed for the incorporation of a new material or fastener in MIL-HDBK-5. Section 9.1.6 of MIL-HDBK-5 specifies the procedure for new materials, while Section 9.4.1.7.1 of MIL-HDBK-5 delineates the method for fasteners. These procedures must be followed by the company (or organization) initiating action to incorporate design data in MIL-HDBK-5 for their products.

After collection of the required data, the data must be analyzed in accordance with the procedures described in Chapter 9 of MIL-HDBK-5. These guidelines provide detailed information concerning the data requirements and the analytical techniques to be employed in the analyses of various types of data to determine minimum or typical design values. A description of the various analytical methods has not been included because Chapter 9 of MIL-HDBK-5 contains this information.

For metallic materials, the Air Force MIL-HDBK-5 contractor frequently analyzes the test data to determine design allowables. Computers are utilized to store and analyze data; consequently, these analyses can be performed efficiently. As an example, Appendix C describes the analysis of data for 17-4PH (H1000) castings performed by Battelle on this contract. For fasteners, the fastener manufacturer which initiates action to incorporate design data for their product into MIL-HDBK-5 conducts the analysis. The MIL-HDBK-5 Fastener Task Group reviews and approves the analysis of fastener data to determine design allowables.

HISTORY

The history of the MIL-HDBK-5 Handbook and the ANC-5 Bulletin has not previously been chronicled. Therefore, an effort has been made to record the past history of these documents. Historical files were searched and the minutes of previous meetings and correspondence were reviewed in an effort to reconstruct previous events. However, early records were not diligently maintained, resulting in meager information in the years prior to 1948. Fortunately, the files did contain most of the revisions of the MIL-HDBK-5 and its predecessor. These revisions were most helpful in arranging the sequence

of events. Although the history, which follows, may not be complete, it is believed that this description conveys a fairly accurate impression of the history of this Handbook. It is hoped that this history will prove interesting, especially for new participants who have just recently become involved with the MIL-HDBK-5 program.

The predecessor to MIL-HDBK-5 was the ANC-5 Bulletin. This document was prepared by the ANC-5 Subcommittee of the Army-Navy-Commerce Committee on Aircraft Design Criteria and issued by the latter. So far as could be determined, the initial issue of this Bulletin occurred in 1937. Revisions of ANC-5 were published in October 1940, December 1942, and October 1943. After the 1943 revision, the activity involving ANC-5 was discontinued until the close of World War II.

The ANC-5 Subcommittee was a part of the Army (Air Force)-Navy-Commerce (Civil) Committee (ANC) on Aircraft Design Criteria. The function of this Committee was defined on March 19, 1946, as follows: "To develop aircraft design criteria governing strength, detailed design, propulsion systems, equipment, flight characteristics, and performance of cargo, transport, training, and military aircraft; and to recommend the adoption of these criteria by the three member branches of the government." The mission of this ANC Committee was carried out by several subcommittees, called ANC-1, ANC-2,, through ANC-17. Later subcommittees, up to ANC-23, were added. These subcommittees, with the exception of ANC-5 and those on materials, expired for unknown reasons. The ANC-5 Subcommittee continued to actively function for two major reasons: (a) The activity of the Subcommittee was fundamental; it was needed; and it did not impinge upon the freedom of industry to innovate, and (b) the Subcommittee was energetically supported by all concerned.

The first meeting of the ANC-5 Group after World War II was apparently on June 5, 1945, according to references. The next meeting was held on May 2, 1946, and attendees consisted of three members (two military and one civilian) from the Army (Air Material Command) and Navy (Bureau of Aeronautics), two members from Civil Aeronautics Administration (CAA), and a recorder from the military (USMC). The Chairman was Mr. E. I. Ryder, CAA. Five people from the Aluminum Company of America and Reynolds Metals also

attended this meeting. The Chairman stated at this meeting that it would be desirable to have members of the aircraft industry present at the next meeting and to encourage industry participation in future revisions of ANC-5.

Mr. William T. Shuler, CAA, succeeded Mr. Ryder as Chairman in 1947. People from various government agencies, the aircraft industry, material suppliers, and fastener suppliers attended the ANC-5 Meeting held on October 7, 1947, swelling attendance to 37. The ANC-5 Committee meetings were held alternately in Washington, D.C., and at Wright-Patterson Air Force Base (Dayton), Ohio. Generally, these meetings were scheduled in the Spring and Fall of the year. On September 21, 1948, the supervisory body for the ANC-5 Subcommittee was changed to the Munitions Board Aircraft Committee. However, the function, operation, and membership of the ANC-5 Group remained essentially unchanged. In September 1953, Mr. J. E. Dougherty, Jr., CAA, became Chairman. The Munitions Board was abolished in 1954, but the ANC-5 Group continued to function as usual.

In 1954, Battelle Memorial Institute (Battelle) was awarded a contract by the Materials Laboratory, Wright-Patterson Air Force Base, Ohio, to review the field of material-property-design criteria for metals used in aircraft and missiles, and to bring up-to-date a compilation of design information for the design of aircraft and missiles. Over the next several years, Battelle published seven Wright Air Development Center technical reports which contained design allowables and other pertinent information for incorporation into ANC-5. Since this initial contract, Battelle has continuously served as the Air Force contractor to maintain and update ANC-5 and MIL-HDBK-5.

In August 1956, the Air Force was assigned the responsibility for maintaining ANC-5. Mr. M. J. Crane, Aeronautical Standards Group (Navy and Air Force), was named Secretariat for the ANC-5 Subcommittee on February 13, 1957.

In 1958 it was decided to publish the next revision as a military handbook. Battelle prepared the initial draft. Military Standardization Handbook MIL-HDBK-5, which superseded ANC-5, was published in March 1959.

Since the abolition of the Munitions Board in 1954, the ANC-5 and MIL-HDBK-5 Committees had been charterless. In 1959 effort was initiated to establish a Joint Committee of the Department of Defense and the Federal

Aviation Agency on "Federal Aircraft Design Criteria". This Joint Committee would have been the governing body for the MIL-HDBK-5 Committee. However, the establishment of this Joint Committee was not promulgated.

At the May 1959 MIL-HDBK-5 Meeting, Mr. J. E. Dougherty, Jr., resigned and Mr. E. S. Newberger, FAA, was appointed Chairman. Mr. Newberger resigned in 1961 and Mr. D. A. Shinn, Aeronautical Systems Division (Air Force), became Acting Chairman for the November 1961 meeting. Mr. Dean Lauver, FAA, assumed Chairmanship and presided at the MIL-HDBK-5 Meeting held in May 1962. Mr. Lauver's Chairmanship was short lived and Mr. D. A. Shinn, Air Force, became the new Chairman. He presided at the meeting held in November 1962. Battelle began preparing the revisions and change notices to MIL-HDBK-5 in 1964.

Messrs. Donald P. Moon and Walter S. Hyler prepared a report, AFML-TR-66-386, "MIL-HDBK-5 Guidelines for the Presentation of Data", dated February 1967. This report specified the analytical procedures and methods for presenting data for MIL-HDBK-5. Prior to that time, many different procedures had been used. Certain procedures had been adopted either formally or informally. In some instances, the techniques had been fairly well documented but were located variously in attachments to the minutes of previous MIL-HDBK-5 meetings, in statistical text and workbooks, in company reports, or in other miscellaneous publications. For this guideline report, procedures were written delineating these past practices. When necessary, analytical techniques were developed. These guidelines represented an important milestone in the utilization of standardized procedures for the analysis and presentation of data for MIL-HDBK-5. This report contained all of the required information for the analysis and presentation of data for MIL-HDBK-5 in one convenient source. All of the procedures contained in these guidelines had been previously approved by the MIL-HDBK-5 Group. These guidelines were later incorporated into MIL-HDBK-5B, September 1971, as Chapter 9.

Beginning with the 39th MIL-HDBK-5 Meeting, April 1970, Battelle prepared and distributed the agenda and minutes of the MIL-HDBK-5 meetings.

At the 46th MIL-HDBK-5 Meeting, held in October 1973, Mr. D. A. Shinn announced that he would be retiring from the Air Force and that he was

stepping down as Chairman. Mr. C. L. Harmsworth, AFML (Air Force), succeeded Mr. Shinn as Chairman and presided at the 46th Meeting.

Battelle prepared a "soft" metric conversion of the first seven chapters of MIL-HDBK-5. This "soft" metric version of MIL-HDBK-5 was published in an Air Force technical report, AFWAL-TR-80-4110, "Metrication of MIL-HDBK-5C", dated August 1980. Although this document was recognized to be limited in its usefulness, the primary benefit of this effort was the revelation of problems associated with the conversion to metric design values and the presentation of metric design data. The experience gained from this "soft" conversion will facilitate the preparation of a future metric version of MIL-HDBK-5 based upon a "hard" conversion, when "hard" metric data become available.

Beginning with MIL-HDBK-5C, Change Notice 3, dated June 1981, the revisions of MIL-HDBK-5 were typeset at Battelle, rather than by the Naval Publications and Forms Center. This change was made to shorten the processing time required to publish MIL-HDBK-5 revisions.

A chronology of the various meetings, meeting places, dates, and ANC-5/MIL-HDBK-5 revisions are listed in Appendix A.

From a technical standpoint, some of the interesting changes and highlights in the evolution of ANC-5 and MIL-HDBK-5 are described in the following paragraphs.

The 1938 version of ANC-5 contained design information for columns, thin-walled sections mechanical property design values for wood, steel alloys, aluminum alloys, and magnesium alloys, as well as design allowables for joints, fittings, and parts. It is interesting to note that the chapter on wood was deleted from ANC-5 in Amendment No. 2, dated August 1946.

Elevated temperature design data for static strength properties and creep data first appeared in ANC-5, dated December 1942. The method of presenting creep data was changed to utilize a nomograph which first appeared in MIL-HDBK-5, Change Notice 5, dated June 1, 1965. New guidelines for analyzing and presenting creep and stress-rupture data were approved at the 58th Meeting, October 1979, and the procedure appeared in MIL-HDBK-5C, Change Notice 3, dated June 30, 1981. This guideline changed the method of presenting creep and stress rupture data from a nomograph to an illustration depicting an isothermal plot of data in the form of stress versus time to produce

a certain percent creep or rupture. Creep and rupture data analyzed in accordance with these new guidelines were first approved for incorporation into MIL-HDBK-5 at the 65th Meeting, May 1983, and the data appeared in MIL-HDBK-5D, Change Notice 1, dated January 1, 1984.

Rotating beam data in the form of S/N curves appeared in ANC-5, dated March 1955. A recommendation by the Task Group on Fatigue that only axial load fatigue data be incorporated into MIL-HDBK-5 and that data be presented in the form of S/N curves or constant-life diagrams was approved at the 22nd Meeting, October 1961. Consequently, the incorporation of rotating beam data was discontinued and existing rotating beam data were deleted from the Handbook since there was little interest in this type of data by the users of MIL-HDBK-5. Subsequent fatigue data incorporated into the Handbook was in the form of constant-life diagrams. At the 61st Meeting, April 1981, a recommendation was made to change the method of analyzing and presenting fatigue data. This recommendation was approved and a change in the guidelines was made in MIL-HDBK-5D, dated January 1, 1983. The new technique involves a statistical procedure for consolidating fatigue data by stress ratio and presenting the resulting data in the form of computer-generated S/N curves. Most of the constant-life diagrams in MIL-HDBK-5 have been replaced with new S/N curves.

Stress-strain and tangent-modulus data were first incorporated into ANC-5, dated May 1949.

The initial design information for titanium alloys was incorporated into MIL-HDBK-5, dated March 1959.

Information on fracture toughness and typical K_{IC} data was approved for incorporation into Chapter 1 of MIL-HDBK-5 at the 35th Meeting, April 1968, and first appeared in MIL-HDBK-5A, Change Notice 3, dated December 1, 1968. After about 10 years of consideration and discussion, a guideline for the analysis and presentation of plane-stress and transitional fracture toughness data was approved for incorporation at the 44th Meeting, October 1972, and first appeared in MIL-HDBK-5B, Change Notice 2, dated August 31, 1973. Residual strength data analyzed in accordance with the new guidelines were approved at the 48th Meeting, October 1974, and first appeared in MIL-HDBK-5B, Change Notice 4, dated August 29, 1975. The first K_{IC} data analyzed in

accordance with the new guidelines were approved at the 49th Meeting, April 1975, and appeared in MIL-HDBK-5B, Change Notice 4, dated August 29, 1975.

At the 44th Meeting, October 1972, agreement was reached to delete column formulas from MIL-HDBK-5. In lieu of these equations, a basic column formula was incorporated together with a brief discussion of column strength, and references to structural analysis methods for columns were added. At this same meeting, a change in the scope of the Handbook was approved. This change indicated that information on element behavior will emphasize those material characteristics needed to assist the design function and that methods of structural analysis are not within the scope of the document. These two changes appeared in MIL-HDBK-5B, Change Notice 2, dated August 31, 1973.

Guidelines for the analysis and presentation of fatigue-crack-propagation data were approved at the 54th Meeting, November 1977. These new guidelines, as well as the first fatigue-crack-propagation data, appeared in MIL-HDBK-5C, Change Notice 1, dated December 15, 1978.

Design information for the first product developed and marketed by a foreign supplier was incorporated into MIL-HDBK-5D via Change Notice 1, dated January 1, 1984. Design allowables for 7010-T73651 and -T7651 plate were added to the Handbook. These products were produced by Alcan Plate Limited, Birmingham, England. The material was fabricated and tested using metric units of measure. The metric mechanical property data were converted to English units for analysis and inclusion in MIL-HDBK-5.

With regard to future technical effort, the development of an analytical procedure for the determination of A and B values from a non-normal distribution (by utilizing the 3-parameter Weibull distribution) has been completed and approval of the guideline is expected at the 68th Meeting, October 1984. Statistically based A and B values have been determined for A357-T6 castings; however, design values cannot be incorporated into MIL-HDBK-5 until a public specification describing these castings is published. A proposed Aerospace Materials Specification is being reviewed and is expected to be published in the near future so that the first A and B values for castings will soon appear in MIL-HDBK-5. A procedure for analyzing strain control fatigue data has been developed. It is anticipated that a guideline procedure for analyzing and presenting strain control fatigue data will be approved

for incorporation into MIL-HDBK-5 in 1985. With the adoption of a procedure for analyzing populations with skewed distributions, it should be feasible to determine statistically based A and B K_{IC} values for those products for which statistical quantities of data are available. It is anticipated that such a procedure will be developed and approved for incorporation into the Handbook in 1985. With such a procedure, A and B K_{IC} values for fracture tough materials can be published in MIL-HDBK-5. Design allowable test programs have been completed or are in progress for a considerable number of new products. It is anticipated that design allowables will be incorporated into MIL-HDBK-5 within the next two years for the following products: Ti-15V-3Cr-3Al-3Sn (STA) sheet, Ti-15V-3Cr-3Al-3Sn (ANN) sheet, Ti-10V-2Fe-3Al (STA) die forging, 7050-T74511 extrusion, 7175-T7452 hand forging, 7175-T7452 die forging, 15-5PH (H1025) plate, and 15-5PH (H925) casting. Much activity is expected with the new aluminum alloys. It is anticipated that design allowables for powder metallurgy (P/M) 7090-T7E71 extrusion and 7090-T7E75 die forgings, as well as ingot metallurgy aluminum-lithium, will be incorporated into the Handbook in the near future.

At some future time, it is anticipated that the information in MIL-HDBK-5 will be computerized so that the data can be stored and transmitted electronically.

APPENDIX A

CHRONOLOGY OF ANC-5/MIL-HDBK-5
MEETINGS AND REVISIONS



DOCUMENTS AND CHRONOLOGY OF ANC-5/MIL-HDBK-5 REVISIONS

Document	Coordination Meeting	Date of Meeting	Place of Meeting	Date of Document	Comments
ANC-5 (Rough Draft)	--	--	--	May 29, 1936	
ANC-5	--	--	--	Nov., 1937	
ANC-5	--	--	--	Jan., 1938	
ANC-5	--	--	--	Oct., 1940	
ANC-5 Amend 1	--	--	--	Dec., 1942	
ANC-5	--	--	--	Oct., 1943	
ANC-5 Amend 2	--	June 1945	--	Aug., 1946	Includes items approved at June, 1945, & May, 1946, Meetings
ANC-5	--	May 1946	--		
ANC-5	1	Oct., 1947	Wash., D.C.		
ANC-5	2	April, 1948	WPAFB		
ANC-5	3	Nov., 1948	Wash., D.C.		
ANC-5A	4	May, 1949	WPAFB	May, 1949	Includes items approved at previous four meetings
ANC-5	5	Nov., 1949	Wash., D.C.		
ANC-5	6	Nov., 1950	Los Angeles		
ANC-5	7	Jan., 1951	WPAFB	June, 1951	Includes items approved at previous three meetings
ANC-5	8	Sept., 1952	Los Angeles		
ANC-5	9	April, 1953	Wash., D.C.		
ANC-5	10	Sept., 1953	Wash., D.C.		
ANC-5	11	Nov., 1953	WPAFB		
ANC-5 Amend 1	12	Oct., 1954	Los Angeles	March, 1955	Includes items approved at 6th thru 10th Meetings
ANC-5	13	Nov., 1955	Wash., D.C.	Nov., 1955	Miscellaneous corrections to March, 1955, revision
ANC-5	14	May, 1956	Los Angeles		
ANC-5	15	Feb., 1957	Wash., D.C.		
ANC-5	16	Sept., 1957	Los Angeles		
ANC-5	17	April, 1958	Wash., D.C.		
MIL-HDBK-5	18	Oct., 1958	Los Angeles		
	19	May, 1959	Wash., D.C.	March, 1959	Includes items approved at 11th thru 16th Meetings
	20	Nov., 1960	Los Angeles		
MIL-HDBK-5		April, 1960	Wash., D.C.	March, 1961	Includes items approved at 17th thru 20th Meetings
		Nov., 1960	Los Angeles		

DOCUMENTS AND CHRONOLOGY OF AWC-5/MIL-HDBK-5 REVISIONS (Continued)

Document	Coordina- tion Meeting	Date of Meeting	Place of Meeting	Date of Document	Comments
MIL-HDBK-5	21	June, 1961	Los Angeles		
	22	Oct., 1961	Wash., D.C.		
	23	May, 1962	Seattle	Aug., 1962	Includes items approved at 21st thr J 23rd Meetings
	24	Oct., 1962	New York		
-5 Change Notice 1	25	April, 1963	San Diego	May, 1963	Includes items approved at 24th and 25th Meetings
-5 Change Notice 2	26	Oct., 1963	Wash., D.C.	Nov., 1963	Includes items approved at 26th Meeting
-5 Change Notice 3	27	April, 1964	Palo Alto	May, 1964	Includes items approved at 27th Meeting
-5 Change Notice 4	28	Oct., 1964	Orlando	Nov., 1964	Includes items approved at 28th Meeting
-5 Change Notice 5	29	April, 1965	Albuquerque	June, 1965	Includes items approved at 29th Meeting
MIL-HDBK-5A	30	Sept., 1965	New York	Feb. 8, 1966	Includes items approved at 30th Meeting
	31	April, 1966	Domey		
-5A Change Notice 1	32	Oct., 1966	Philadelphia	Nov. 30, 1966	Includes items approved at 31st and 32nd Meetings
-5A Change Notice 2	33	April, 1967	Seattle	July 24, 1967	Includes items approved at 33rd Meeting
	34	Oct., 1967	Atlanta		
	35	April, 1968	San Diego		
-5A Change Notice 3	36	Sept., 1968	Boston	Dec. 1, 1968	Includes items approved at 34th thru 36th Meetings
	37	April, 1969	Anaheim		
-5A Change Notice 4	38	Sept., 1969	Ann Arbor	Jan. 5, 1970	Includes items approved at 37th and 38th Meetings
	39	April, 1970	Las Vegas		
	40	Nov., 1970	Warren		
MIL-HDBK-5B	41	April, 1971	San Francisco	Sept. 1, 1971	Includes items approved at 39th thru 41st Meetings
	42	Oct., 1971	Richmond, VA		
-5B Change Notice 1	43	April, 1972	Redondo Beach	July 1, 1972	Includes items approved at 42nd and 43rd Meetings
	44	Oct., 1972	Pittsburgh		
-5B Change Notice 2	45	April, 1973	Tulsa	Aug. 31, 1973	Includes items approved at 44th and 45th Meetings
	46	Oct., 1973	New Haven		
-5B Change Notice 3	47	April, 1974	Santa Ana	Aug. 15, 1974	Includes items approved at 46th and 47th Meetings
	48	Oct., 1974	Dearborn		
-5B Change Notice 4	49	April, 1975	Columbus	Aug. 29, 1975	Includes items approved at 48th and 49th Meetings

DOCUMENTS AND CHRONOLOGY OF AWC-5/MIL-HDBK-5 REVISIONS (Continued)

Document	Coordina- tion Meeting	Date of Meeting	Place of Meeting	Date of Document	Comments
MIL-HDBK-5C	50	Oct., 1975	Buena Park		
	51	April, 1976	Buena Park	Sept., 15, 1976	Includes items approved at 50th and 51st Meetings
	52	Oct., 1976	Atlanta		
	53	April, 1977	San Francisco		
	54	Nov., 1977	Annapolis		
-5C Change Notice 1	55	April, 1978	San Diego	Dec. 15, 1978	Includes items approved at 52nd thru 55th Meetings
	56	Oct., 1978	Cincinnati		
-5C Change Notice 2	57	April, 1979	Albuquerque	Dec. 1, 1979	Includes items approved at 56th and 57th Meetings
	58	Oct., 1979	Portland, MA		
	59	April, 1980	Seattle		
-5C Change Notice 3	60	Oct., 1980	M. Palm Beach	June 30, 1981	Includes items approved at 58th thru 60th Meetings
	61	April, 1981	Monterey		
	62	Oct., 1981	Indianapolis		
MIL-HDBK-5D	63	May, 1982	Phoenix	June 1, 1983	Includes items approved at 61st thru 63rd Meetings
	64	Oct., 1982	St. Louis		
-5D Change Notice 1	65	May, 1983	Denver	Jan. 1, 1984	Includes items approved at 64th and 65th Meetings
	66	Oct., 1983	Dayton		
	67	May, 1984	Portland, OR		

APPENDIX B

**REQUIREMENTS FOR NEW MATERIALS TO
BE INCORPORATED INTO MIL-HDBK-5**

9.1.6 REQUIREMENTS FOR NEW MATERIALS.—This section describes the requirements for incorporating new materials into MIL-HDBK-5 on an S-basis (see Section 9.2.2.1 for definition). To be considered for inclusion in MIL-HDBK-5 a material must be covered by a Government specification (Military or Federal) or industry specification (as issued by industry standardization groups such as SAE Aerospace Materials Division, ASTM, etc.). Only one product form shall be included in each data set submitted.

9.1.6.1 Test Requirements.—The following test requirements are specified to provide data for room-temperature property table:

(1) The data shall be comprised of paired tensile and compressive measurements for each significant test direction representing at least ten lots* of material obtained from at least two production heats for each product form and heat-treat condition. Test specimens for paired measurements shall be located in close proximity. If coupons or specimens are machined prior to heat treatment, the coupons or specimens representing paired measurements shall be heat treated simultaneously in the same heat-treat load through all heat-treating operations. Included in the ten lots should be data covering the thickness ranges specified by the material specification. Tension allowables in other than specified test directions and compression allowables should be computed by the derived ratio procedure as described in Section 9.2.9.

(2) The same group of lots as in (1) shall be tested in shear and bearing, in order to establish derived property ratios for these properties. Bearing tests will be conducted for $e/D = 1.5$ and $e/D = 2.0$ ratios. These tests also should involve the significant grain directions for the product form.

(3) From the lots tested in (1), modulus of elasticity in tension and compression should be obtained from at least 3 lots, preferably precision modulus values. As indicated in Section

9.3.2.2, ASTM E83 Class A extensometers are preferred but Class B extensometers may be used.

(4) For those materials which are used exclusively in high temperature applications, such as gas turbine or rocket engines, the data requirements for compression, shear, and bearing properties may be waived by the MIL-HDBK-5 Coordination Group. In lieu of these data, sufficient data for the construction of elevated temperature curves for tensile yield and ultimate strengths, as well as tensile modulus of elasticity, shall be submitted in accordance with the data requirements specified in Sections 9.3.1.1 and 9.3.1.3, respectively.

9.1.6.2 Required Tables and Curves.—(1) A room temperature table will be prepared and will contain F_{tu} , F_{ty} , F_{cy} , F_{tu} , F_{br} , e , E , and E_c values in the significant grain directions over the thickness range considered. Physical properties, ω , α , C and K also shall be reported in the room-temperature table, when available. Reference temperatures shall be indicated for curves on effect of temperature upon physical properties. If the F_{cy} , F_{ty} , F_{tu} , F_{br} and F_{br} properties have been waived, obviously these values will be omitted from the room-temperature table and curves showing the effect of temperature on tensile yield strength, tensile ultimate strength, and tensile modulus of elasticity shall be included.

(2) Representative room-temperature load or stress-strain curves from actual tests on at least three lots or heats shall be included. Typical (as defined by Section 9.3.2.1) stress-strain curves, preferably full range, Ramberg-Osgood parameter values and tangent-modulus curves will be prepared as described in Section 9.3.2 and provided as a portion of the proposed addition to the Handbook. For heat resistant materials for which elevated temperature curves for tensile yield and ultimate strengths are required, elevated temperature stress-strain curves representing the elevated temperature tensile tests shall be prepared.

*For a single form and thickness, data from no more than one heat-treat lot per heat may be used to meet the ten lot requirement

9.1.6.3 Report Requirements.—(1) A report shall be submitted to the MIL-HDBK-5 Coordination Activity that contains the proposed addition to the Handbook as described below. The proposed addition shall contain a section on Comments and Properties which provides brief information on metallurgical, manufacturing and environmental factors, specifications and heat treatments or conditions. In addition, the report shall contain a room-temperature property table, stress-strain curves, and curves showing effect of temperature on physical properties, when data are available. For certain heat resistant alloys as described above, the report shall contain curves showing the effect of temperature on the tensile yield and ultimate strengths as well as tensile modulus of elasticity.

(2) The report also should contain all of the test data identified by heat or lot and heat treatment. The report should contain the specific computations involved in the analysis of derived properties, in the analysis of the various other properties, and in the analysis of the various stress-strain relationships described above.

(3) Frequently, other testing is done which can provide very useful information. This testing includes the effect of temperature on various properties, creep, stress rupture, fatigue-crack-propagation, fracture toughness and fatigue tests. Inclusion in the report of such data, even though limited in nature, is requested. For most of these data, specific discussion of test specimens and procedures will be necessary.

APPENDIX C

**TEST PROGRAM FOR DETERMINATION OF DESIGN
ALLOWABLES FOR 17-4PH (H1000) CASTING**

Item 79-21. Design Allowables (Derived Properties) for
17-4PH (H1000) Casting

Background - Currently MIL-HDBK-5 does not contain design values for compressive yield, shear ultimate, bearing yield, and bearing ultimate strengths for 17-4PH castings. At the 58th MIL-HDBK-5 Coordination Meeting, it was indicated that these design allowable properties were needed for the H1000 heat treat condition. Since there were no test data available in the open literature, it was decided that Battelle should initiate a test program to obtain the required data. Accordingly, letters were sent to 19 casting suppliers and 35 aerospace companies, inquiring as to whether production castings could be supplied for this test program.

Material - As a result of this request, castings or portions of castings were furnished by Arwood Corp., Golden State Castings, Inc., and Hemet Casting Co. In addition, parts cast by Bescast, Inc., were received from Detroit Diesel Allison and castings produced by Golden State Castings, Inc., were furnished by Hughes Helicopters. All castings were supplied at no cost to the MIL-HDBK-5 program. The castings had been produced to AMS 5343, AMS 5355 or comparable specifications. Castings which would yield the greatest number of test specimens were selected for testing. Fifteen castings representing four foundries were chosen to provide test specimens. The thickness of these castings varied from 3/8 to 3 inches. Sketches of the selected castings or portions of castings are shown in Figures 1 through 10.

The castings received from Arwood and Detroit Diesel Allison were not in the proper heat treat condition. Consequently, these test parts were heat treated by a commercial heat treater to the H1000 condition in accordance with AMS 5343 and AMS 5355 using the following procedure:

- (1) Heat to 2100 ± 25 F, hold at heat for not less than 90 minutes, and cool to below 70F.
- (2) Heat to 1900 ± 25 F, hold at heat for 1 hour per inch of thickness but not less than 30 minutes and cool to below 70F.
- (3) Heat to 1000 ± 15 F, hold at heat for not less than 90 minutes and air cool to room temperature.

The heat treatment was performed in salt bath furnaces.

Test Plan - As defined in Chapter 1, Section 1.4.1.3 of MIL-HDBK-5, derived values are those room temperature mechanical property values that are established through their relationship to directly calculated (or specification) values for room temperature F_{tu} and F_{ty} . The guideline for the presentation of data, as described in Chapter 9, Section 9.2.9.1 of MIL-HDBK-5, requires at least ten pairs of measurements, each representing a single lot of material. Based upon the available castings, Table 1 shows the test plan to acquire the necessary data.

Test Specimens - Suitable castings were selected so that, in general, duplicate specimens could be obtained (Table 1). In some cases, triplicate shear specimens were utilized. Because of the size and configuration of the castings, subsize test specimens were employed. The configurations of the test specimens are shown in Figures 11 through 15. The locations of the test specimens for each part are indicated in Figures 1 through 10.

In order to determine internal quality, the test specimens were radiographed after machining. The acceptable defects in the test specimens did not exceed the requirement for Grade B of MIL-A-21180.

Testing - All testing was performed at room temperature. Prior to conducting the bearing tests, all pins, specimens, and fixtures were ultrasonically cleaned in acetone. After cleaning, white gloves were used in the handling of pins, specimens and fixtures. The results of the mechanical property tests are shown in Table 2. The tensile properties of all castings conformed to the requirements of AMS 5343.

Analysis - As previously indicated, derived values refer to those room temperature mechanical property values that are established through their relationships to directly calculated (or specification) values for room temperature F_{tu} and F_{ty} . The procedure is applicable to F_{cy} , F_{su} , F_{bru} , and F_{bry} and involves the pairing of SUS and BUS measurements with TUS measurements for which F_{tu} has been established. Likewise, CYS and BYS measurements are paired with TYS measurements for which F_{ty} has been established.

Using the above relationships, reduced ratios for the various "unknown" properties were determined using the computational procedure described in Chapter 9, Section 9.2.9.2 of MIL-HDBK-5. The compression, shear, and bearing ratios are shown in Tables 3 and 4. Since thickness did not appear to have a significant effect on these ratios, reduced ratios were computed using the following equation:

$$R = \bar{r} - \frac{t_{0.95}s}{\sqrt{n}}$$

where R = reduced ratio

\bar{r} = average of n ratios

s = standard deviation of the ratios

$t_{0.95}$ = the 0.95 fractile of the t distribution corresponding to n-1 degrees of freedom

n = number of ratios.

A computer program was used to perform the analyses. The reduced ratios are shown in Tables 3 and 4. A comparison of the reduced ratios for 17-4PH (H1000) castings with those for 17-4PH (H1025) bar, as determined in references (1) and

(1) Ruff, P. E., "Determination of Selected MIL-HDBK-5 Design Allowable Properties for Five Aerospace Materials", AFML-TR-75-58, Battelle's Columbus Laboratories, May 1975.

(2), as shown in Table 5. The reduced ratios for castings compare closely with those for bar.

Using the reduced ratios in Tables 3 and 4, design values for compression yield, shear, ultimate, bearing yield, and bearing ultimate strengths were computed. Existing MIL-HDBK-5 Tables 2.6.9.0(i) and (j) have been revised to include design allowables for these properties for the H1000 condition. A footnote was added to these tables to indicate that bearing values are "dry pin" values.

The tension and compression load-strain curves from this investigation were analyzed in accordance with Section 9.3.2 of MIL-HDBK-5 for the purpose of constructing typical stress-strain curves. The Ramberg-Osgood shape parameter for the 29 tension stress-strain curves varied from 12 to 20. The Ramberg-Osgood parameter determined from the analysis of combined data was 16. The Ramberg-Osgood shape parameter for the 24 compressive stress-strain curves varied from 10 to 20. The Ramberg-Osgood parameter determined from the analysis of combined data was 13. Typical tensile yield and compressive yield strengths were determined from an average of all values in Table 2. The moduli of elasticity in tension and compression were obtained from proposed Tables 2.6.9.0(i) and (j). Using these three parameters, typical tensile stress-strain, compressive stress-strain, and compressive tangent-modulus curves were constructed. These curves are presented in Figures 2.6.9.5.6(a) and (b).

(2) Ruff, P. E. and Smith, S. H., "Development of MIL-HDBK-5 Design Allowable Properties and Fatigue-Crack-Propagation Data for Several Aerospace Materials", AFML-TR-77-162, Battelle's Columbus Laboratories, October 1977.

TABLE 1. TEST PLAN FOR 17-4PH (H1000) CASTING

Part Identi- fication	Casting Supplier	Tensile	Compression	Shear	Bearing, e/D = 1.5	Bearing, e/D = 2.0
AA	Arwood	2 ^a	2	2	2	2
AB	Arwood	2		3	2	
AC	Arwood	2		3		2
HA	Hemet	2	2	2	2	2
HB	Hemet	2	2	2	2	2
HC	Hemet	2	2	2	2	1
HD	Hemet	2			2	2
BA	Bescast	2	2	2	2	
BB	Bescast	2	2	2		2
GA	Golden State	2	2	3	2	
GB	Golden State	2	2	3		2
GC	Golden State	2	2	3	2	
GD	Golden State	2	2	3		2
GE	Golden State	2	2	3	2	
GF	Golden State	2	2	3		2

^aIndicates number of test specimens.

TABLE 2. MECHANICAL PROPERTIES OF 17-4PH (H1000) CASTING

Part Identification	Section Thickness, inches	Specimen Identification	Tensile			Elongation, %	Reduction of Area, %	Compression		Shear Ultimate Strength, ksi	Bearing $\sigma/D = 1.5$		Bearing $\sigma/D = 2.0$	
			Ultimate Strength, ksi	Yield Strength, ksi	Yield Strength, ksi			Ultimate Strength, ksi	Yield Strength, ksi		Ultimate Strength, ksi	Yield Strength, ksi		
AA	0.485	AA1	163.9	158.5	6	0	163.2	109.4	205.0	230.2	265.9	273.0		
		AA2	165.5	155.5	14	0	163.9	104.6	204.0	232.4	265.9	281.0		
		AVG.	164.7	157.0	10		163.5	109.1	204.2	235.2	265.9	277.4		
AB	0.625	AB1	168.3	159.4	19	32.0	168.7	108.1	207.0	224.9				
		AB2	168.0	159.9	18	31.7	168.9	108.7	209.9	237.0				
		AVG.	168.2	159.6	18.5	31.2	168.9	109.6	208.9	231.3				
AC	0.625	AC1	165.5	155.0	17	32.2	168.4	108.4			261.9	269.4		
		AC2	165.6	156.3	16	31.0	168.6	108.6			267.2	270.7		
		AVG.	165.6	155.6	16.5	31.6	168.5	108.6			264.5	270.0		
MA	0.375	MA1	173.1	164.9	19	36.8	169.8	114.6	207.5	248.0	301.0	290.6		
		MA2	174.0	166.6	19	36.8	170.2	114.7	204.6	245.2	301.0	290.6		
		AVG.	165.8	165.8	19	36.2	170.0	114.7	206.0	246.6	301.0	282.1		
MB	1.000	MB1	164.2	158.3	23	31.6	161.2	109.0	276.7	284.9				
		MB2	163.3	156.6	16	25.5	158.8	107.5	276.3	233.1				
		AVG.	163.8	157.4	20.5	28.6	160.0	108.2	276.5	234.0				
MC	0.500	MC1	164.7	158.6	24	51.3	162.0	107.6	281.2	222.0	359.9	274.6		
		MC2	164.5	158.2	25	54.4	161.2	105.6	280.2	232.2	359.9	274.6		
		AVG.	164.6	158.4	24.5	53.0	161.6	106.7	280.7	227.5	359.9	274.6		
MD	0.150	MD1	167.3	157.6	10	0			286.8	241.6	378.9	292.3		
		MD2	167.3	157.6	10	0			286.8	241.6	378.9	292.3		
		AVG.	167.3	157.6	10	0			286.8	241.6	378.9	292.3		
MA	3.000	MA1	161.7	156.6	13	20.6	158.9	107.4	276.3	228.0				
		MA2	161.7	156.3	20	39.4	161.7	107.4	272.0	228.6				
		AVG.	161.7	156.4	16.5	30.0	160.3	107.4	272.0	228.6				
MB	3.000	MB1	162.6	157.7	21	41.8	160.8	107.5	280.2	228.7				
		MB2	162.6	157.7	20	41.4	162.0	108.0	280.2	228.7				
		AVG.	162.7	157.7	20.5	41.7	161.4	108.0	280.2	228.7				
CA	0.500	CA1	163.5	155.0	20	37.5	161.0	108.4	280.8	232.0				
		CA2	163.4	156.5	22	47.7	161.9	108.0	283.6	234.2				
		AVG.	164.4	155.7	21	42.6	162.4	108.4	282.2	233.1				
CB	0.500	CB1	163.9	159.2	19	36.8	162.1	107.4	282.2	233.1				
		CB2	161.6	158.5	20	34.2	162.7	107.7	282.2	233.1				
		AVG.	163.6	158.8	19.5	35.5	162.4	107.3	282.2	233.1				
CC	0.500	CC1	164.8	157.9	14	29.7	161.9	107.9	286.0	239.1				
		CC2	161.6	158.5	16	33.6	159.0	108.3	286.0	239.1				
		AVG.	165.1	158.1	15	31.6	160.4	107.4	286.0	239.1				
CD	0.500	CD1	164.8	157.3	14	26.2	161.0	107.9	282.9	233.2				
		CD2	165.3	156.7	14	24.5	163.4	107.6	282.9	233.2				
		AVG.	165.0	157.0	14	25.3	162.2	108.4	282.9	233.2				
CE	0.500	CE1	161.7	151.2	24	47.6	146.5	107.6	276.1	235.1				
		CE2	166.6	158.5	16	31.6	156.9	109.3	275.9	222.6				
		AVG.	164.1	154.8	20	39.6	156.7	108.1	275.9	222.6				
CF	0.375	CF1	164.2	157.5	20	40.6	158.9	107.7	275.0	223.8				
		CF2	162.2	156.8	9	16.1	159.3	107.6	275.0	223.8				
		AVG.	163.2	156.1	14.5	28.2	159.1	107.7	275.0	223.8				

a) Flat tensile specimen.
 b) Failure through radiographic defect decreased strength.
 c) Specimen insufficient in length for double shear.
 d) Premature failure through clevis pin hole due to insufficient width of specimen.
 e) Cracked specimen.

TABLE 3. YIELD STRENGTH PATIJS FOR 17-4PH(H1030) CASTING

IDENTIFICATION	TYS	e/D = 1.5		e/D = 2.0
		$\frac{CYS}{TYS} \times 100$	$\frac{BYS}{TYS} \times 100$	$\frac{BYS}{TYS} \times 100$
PART AA 0.485 THICK	157.0	104.1	149.9	176.7
PART AB 0.625 THICK	159.6	-0	144.9	-0
PART AC 0.625 THICK	155.6	-0	-0	173.5
PART HA 0.375 THICK	165.8	102.5	148.7	170.1
PART HB 1.000 THICK	157.4	101.7	146.7	169.6
PART HC 0.500 THICK	156.4	102.0	143.6	173.4
PART HD 0.150 THICK	157.6	-0	157.2	184.1
PART BA 3.000 THICK	150.4	102.5	146.2	-0
PART BB 3.000 THICK	157.7	102.3	-0	169.4
PART GA 0.500 THICK	153.7	104.7	149.7	-0
PART GB 0.500 THICK	153.8	102.3	-0	172.8
PART GC 0.500 THICK	158.1	101.5	148.8	-0
PART GD 0.500 THICK	157.0	103.3	-0	172.7
PART GE 0.500 THICK	154.8	101.2	144.6	-0
PART GF 0.375 THICK	156.1	101.9	-0	174.2
NUMBER R		12	10	10
AVG R		102.5	142.2	173.5
SUM R		1229.7	1482.3	1735.5
SUMSQ R		126018.3	219867.2	301379.3
SDEV R		0.9847	3.3902	4.4374
SDEV FBAR		0.2843	1.2302	1.4032
PERCENT		102.0	145.9	170.9

TABLE 4. ULTIMATE STRENGTH RATIOS FOR 17-4PH(H1030) CASTING

IDENTIFICATION	TUS	e/D=1.5		e/D=2.0
		$\frac{SUS}{TUS} \times 100$	$\frac{BUS}{TUS} \times 100$	$\frac{BUS}{TUS} \times 100$
PART AA 0.485 THICK	164.7	66.2	173.0	222.2
PART AB 0.625 THICK	168.2	65.2	171.8	-0
PART AC 0.625 THICK	165.4	65.7	-0	220.4
PART HA 0.375 THICK	174.0	65.9	170.1	219.0
PART HB 1.000 THICK	163.8	65.1	168.8	-0
PART HC 0.500 THICK	164.6	64.8	170.5	218.7
PART HD 0.150 THICK	167.3	-0	169.6	225.8
PART BA 3.000 THICK	161.7	66.4	169.2	-0
PART BB 3.000 THICK	162.7	66.4	-0	-0
PART GA 0.500 THICK	164.4	66.0	171.7	-0
PART GB 0.500 THICK	163.6	65.6	-0	219.4
PART GC 0.500 THICK	165.1	65.4	171.2	-0
PART GD 0.500 THICK	165.0	65.3	-0	219.0
PART GE 1.500 THICK	164.1	65.9	167.6	-0
PART GF 1.375 THICK	163.2	66.0	-0	222.7
NUMBER	14	10	8	
AVG R	65.8	170.3	221.9	
SUM R	921.7	1703.4	1767.0	
SUMSQ R	60557.2	290192.6	399326.6	
SDEV R	0.4776	1.6076	2.4658	
SDEV R/SR	0.1276	0.5064	0.8789	
PERCENT	65.5	169.4	219.2	

**TABLE 5. REDUCED RATIOS FOR 17-4PH (H1000) CASTING
COMPARED TO 17-4PH (H1025) BAR**

Ratio	17-4PH (H1000) Casting	17-4PH (H1025) Bar
CYS/TYS	1.020	0.963 ^a
SUS/TUS	0.655	0.614
BUS/TUS		
e/D = 1.5	1.694	1.697
e/D = 2.0	2.192	2.146
BYS/TYS		
e/D = 1.5	1.459	1.458
e/D = 2.0	1.709	1.729

^aAll reduced ratios are for longitudinal grain direction.

TABLE 2.6.9.0(i). *Design and Physical Properties of 17-4PH Stainless Steel (Investment) Casting*

Specification	AMS 5344	AMS 5343	AMS 5342
Form	Investment casting		
Condition	a	H1000 ^b	H1100 ^c
Thickness, in.
Basis	S	S	S
Mechanical properties:			
F_{Tu} , ksi	180	150	130
F_{Ty} , ksi	160	130	120
F_{U} , ksi	132	...
F_{m} , ksi	98	...
F_{br} ^d ksi:			
(e/D=1.5)	254	...
(e/D=2.0)	329	...
F_{br} ^d ksi:			
(e/D=1.5)	189	...
(e/D=2.0)	222	...
e, percent	4	4	6
RA, percent	12	12	15
E , 10 ³ ksi	28.5		
E_r , 10 ³ ksi	30.0		
G, 10 ³ ksi	12.7		
μ	0.27		
Physical properties:			
α , lb/in. ³	0.282 (H900)		
C, K, and α	See Figure 2.6.9.0.		

^a Aged at 900-925 F for 90 minutes.

^b Aged at 985-1015 F for 90 minutes.

^c Aged at 1065-1115 F for 90 minutes.

^d Bearing values are "dry pin" values per Section 1.4.7.1.

TABLE 2.6.9.0(j). Design and Physical Properties of 17-4PH Stainless Steel (Casting)

Specification	AMS 5355				AMS 5398
	Investment casting				Sand casting
Form.....	H900	H925	H1000	H1100	H925
Condition.....
Thickness, in.....
Basis	S ^a	S ^a	S ^a	S ^a	S ^a
Mechanical properties:					
F_{tu} , ksi	180	180	150	130	180
F_{Ty} , ksi	160	150	130	120	150
F_{Tz} , ksi	132
F_{su} , ksi	98
F_{bu}^b , ksi:					
(e/D=1.5)	254
(e/D=2.0)	329
F_{bz}^b , ksi:					
(e/D=1.5)	189
(e/D=2.0)	222
e , percent	6	6	8	8	6
RA, percent	15	15	20	15	12
E , 10 ³ ksi	28.5				
E_c , 10 ³ ksi	30.0				
G , 10 ³ ksi	12.7				
μ	0.27				
Physical properties:					
α , lb/in. ³	0.282 (H900)				
C, K, and α	See Figure 2.6.9.0.				

^aFor separately cast bars. Properties of test specimens machined from castings shall be as agreed upon by purchaser and supplier

^bBearing values are "dry pin" values per Section 1.4.7.1.

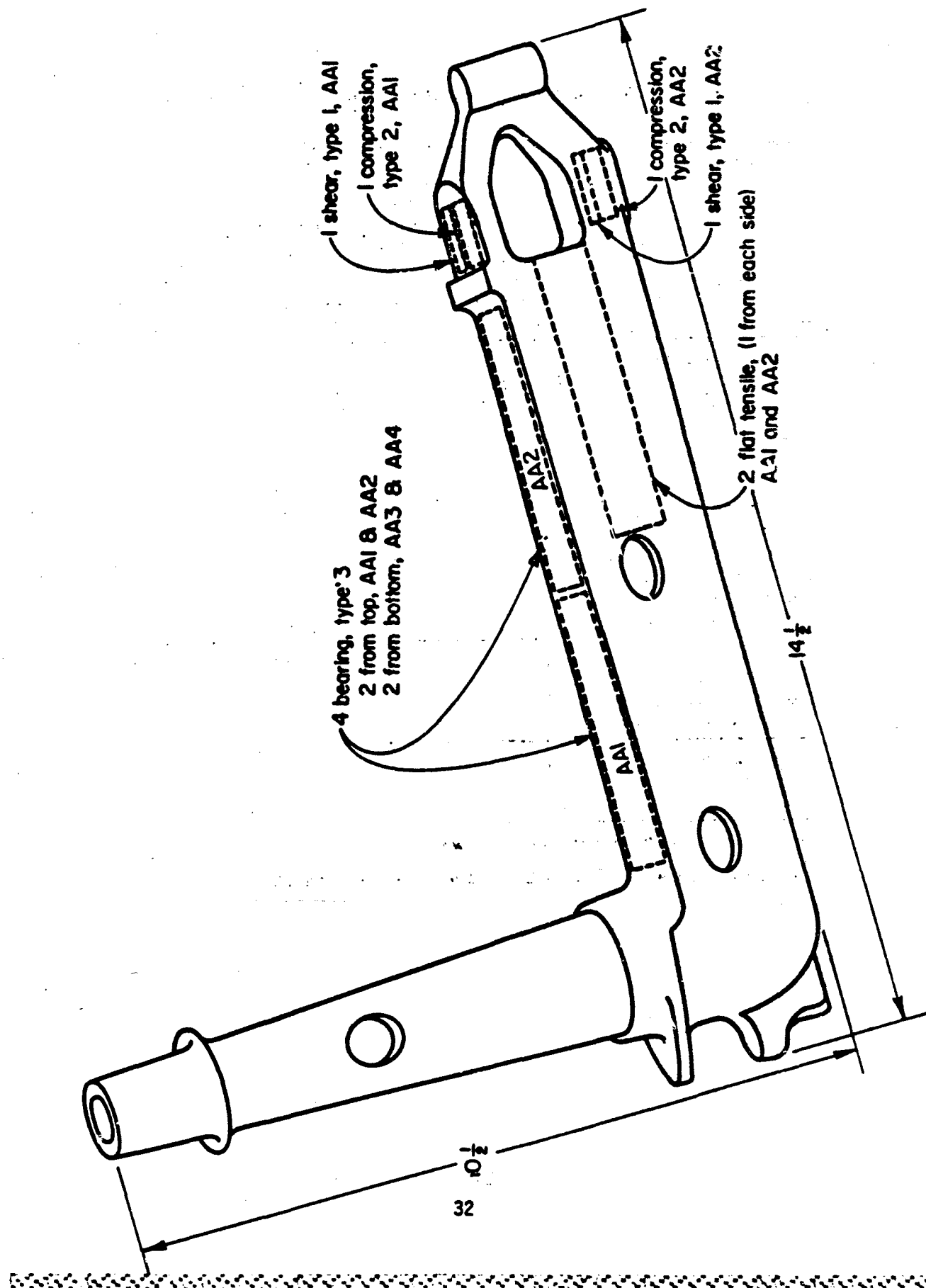

FIGURE 1. LOCATION OF TEST SPECIMENS FOR CASTING AA

Note: Specimens from similar part identified AC1, AC2, etc

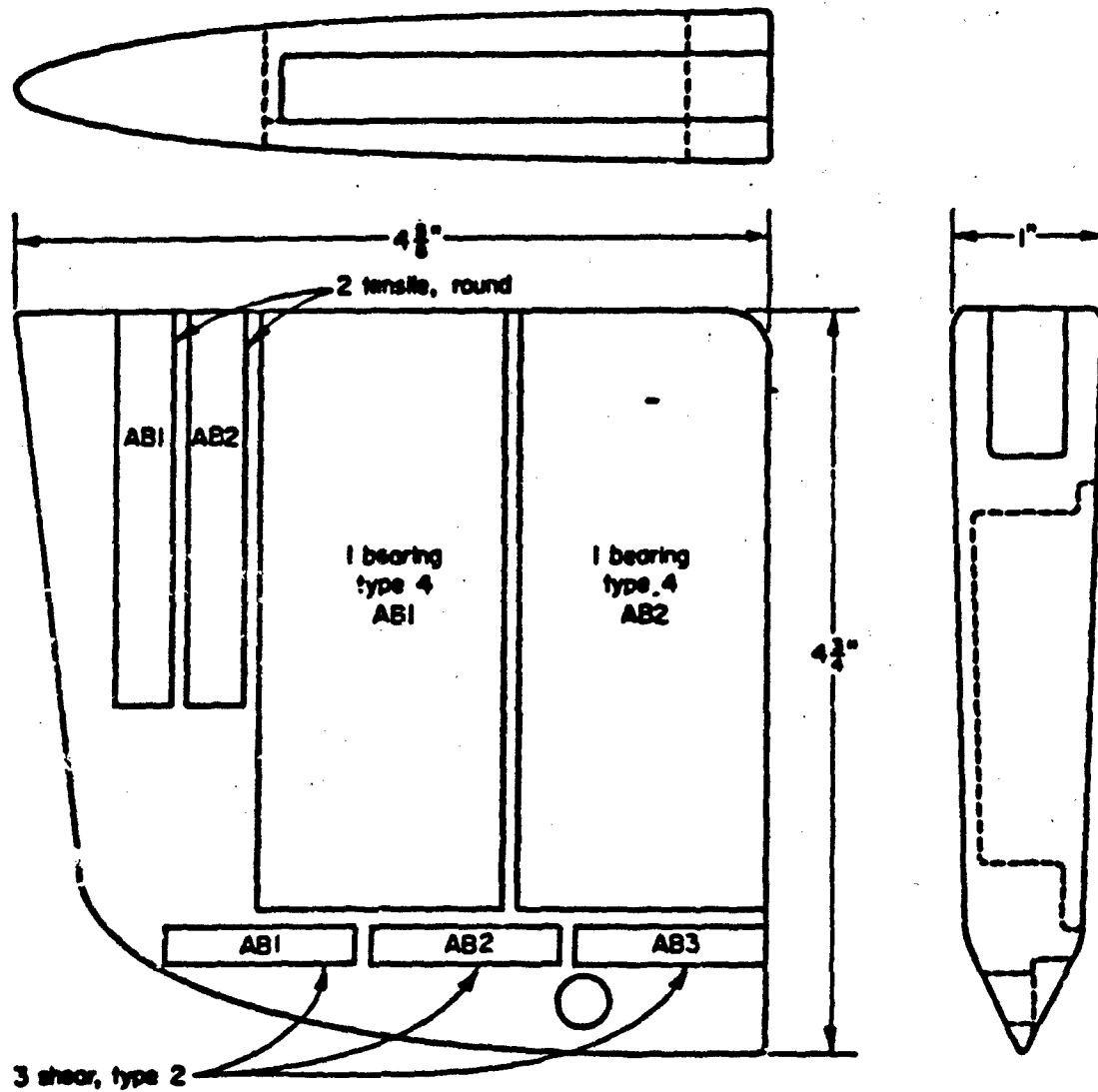

FIGURE 2. LOCATION OF TEST SPECIMENS FOR CASTINGS AB AND AC

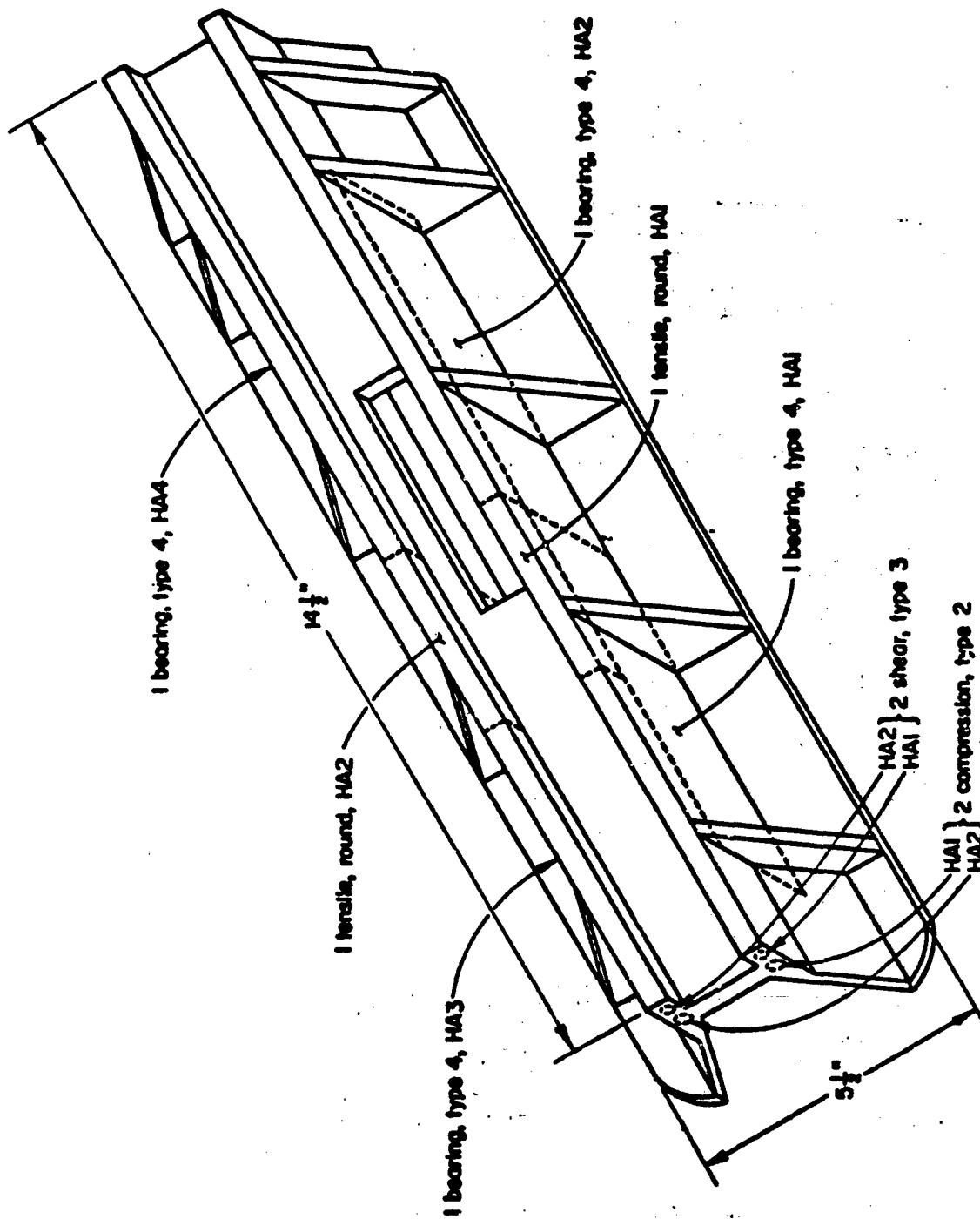

FIGURE 3. LOCATION OF TEST SPECIMENS FOR CASTING HA

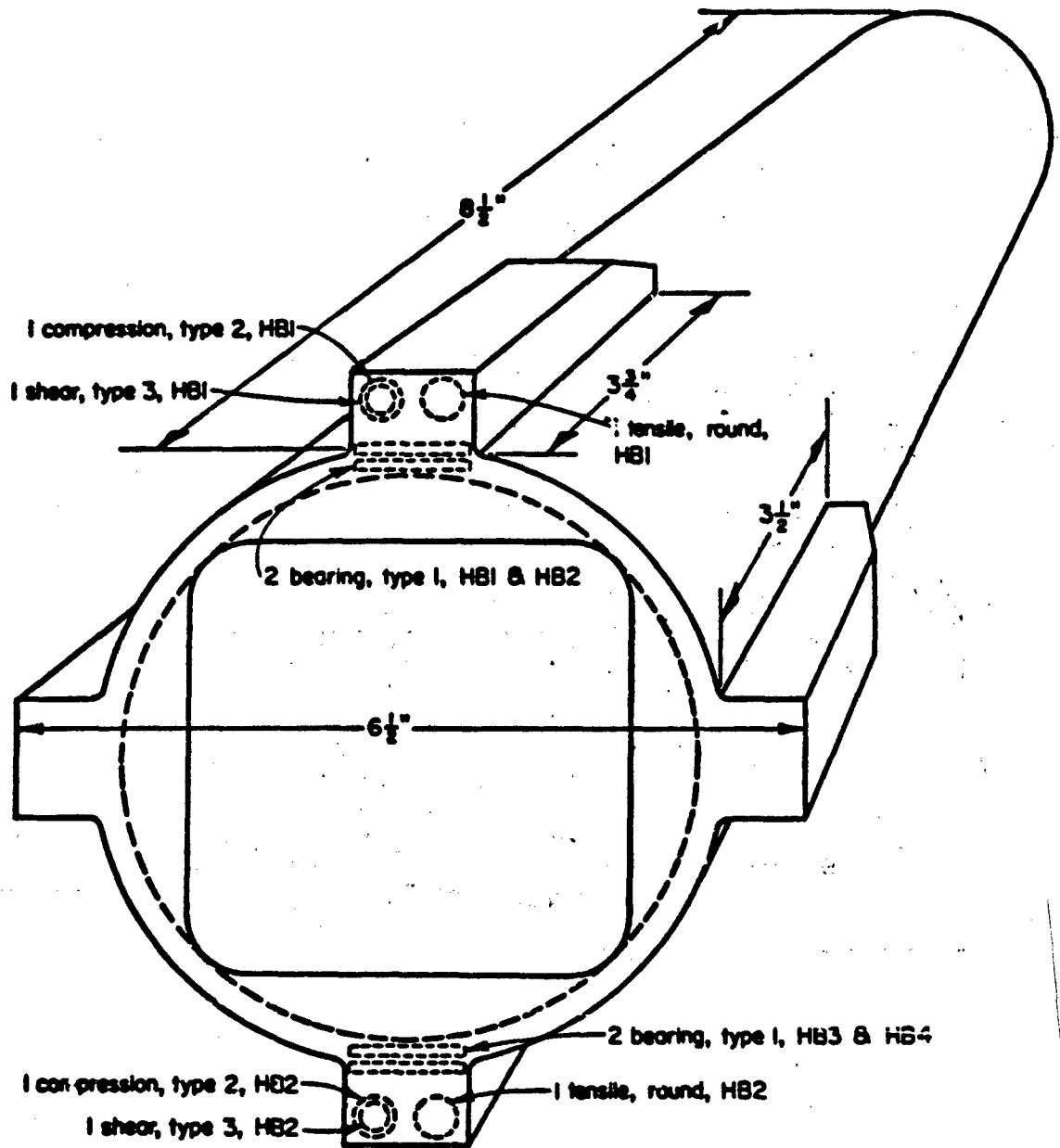

FIGURE 4. LOCATION OF TEST SPECIMENS FOR CASTING HB

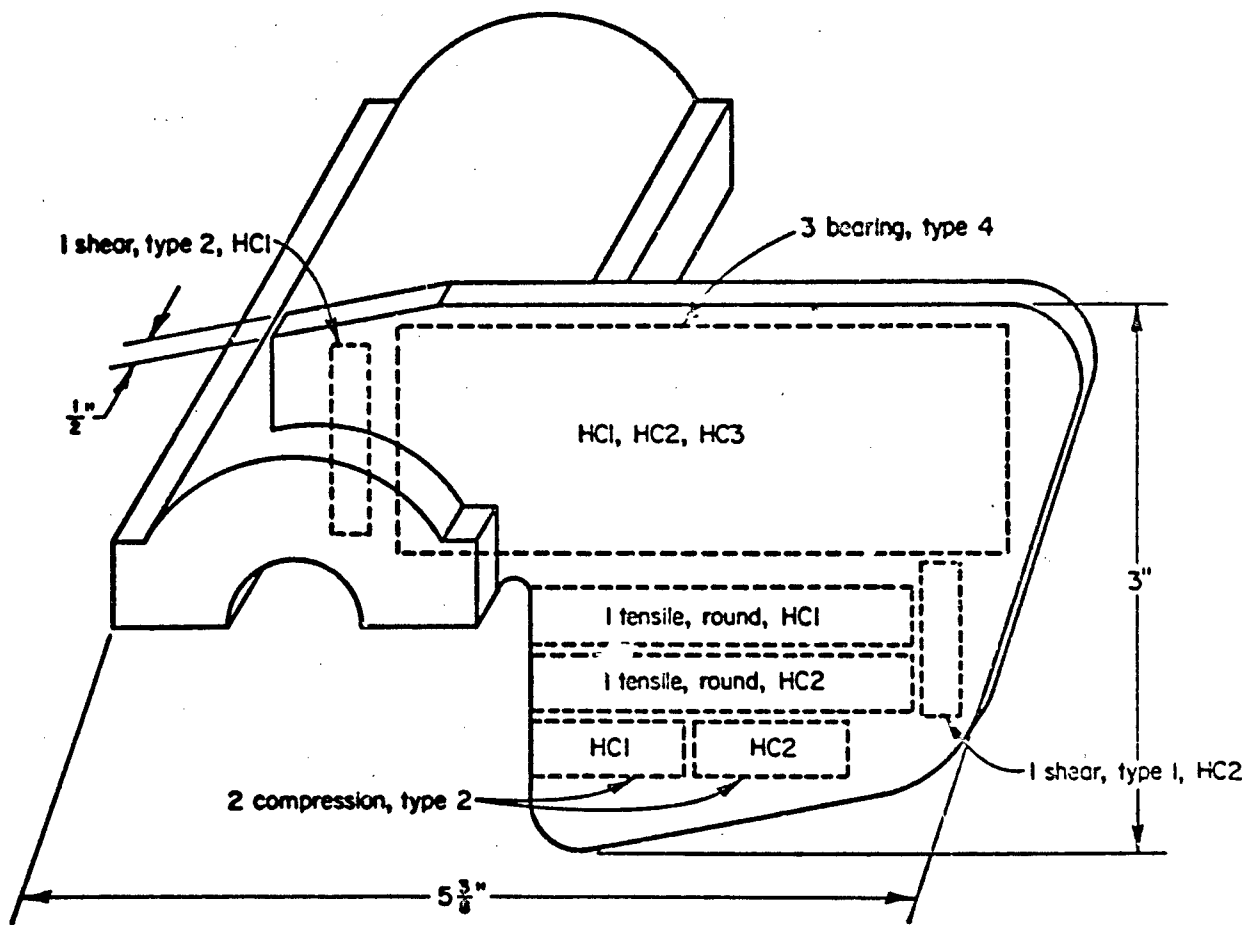

FIGURE 5. LOCATION OF TEST SPECIMENS FOR CASTING HC

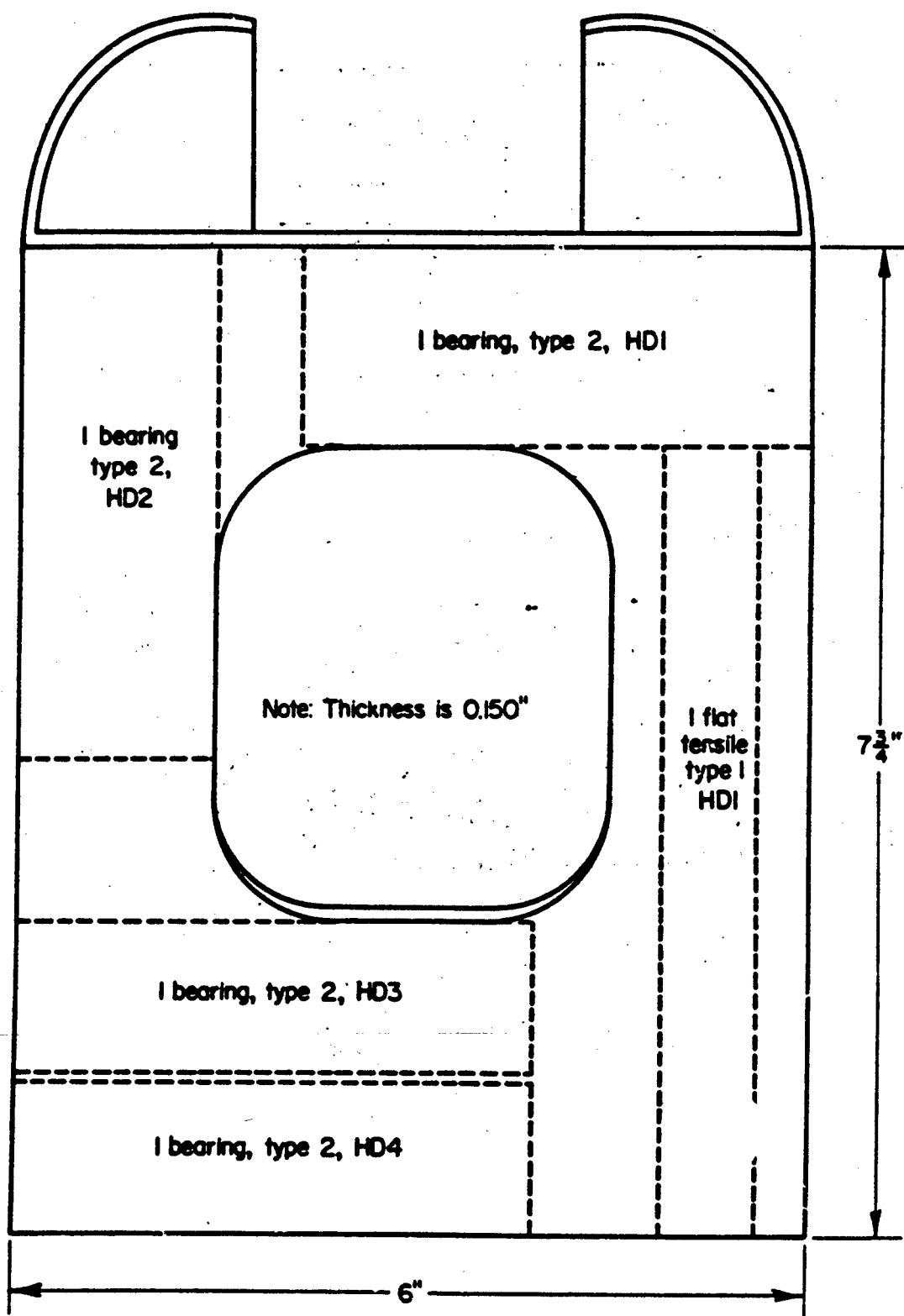

FIGURE 6. LOCATION OF TEST SPECIMENS FOR CASTING HD

Note: Specimens from similar part identified BBI, BB2, etc

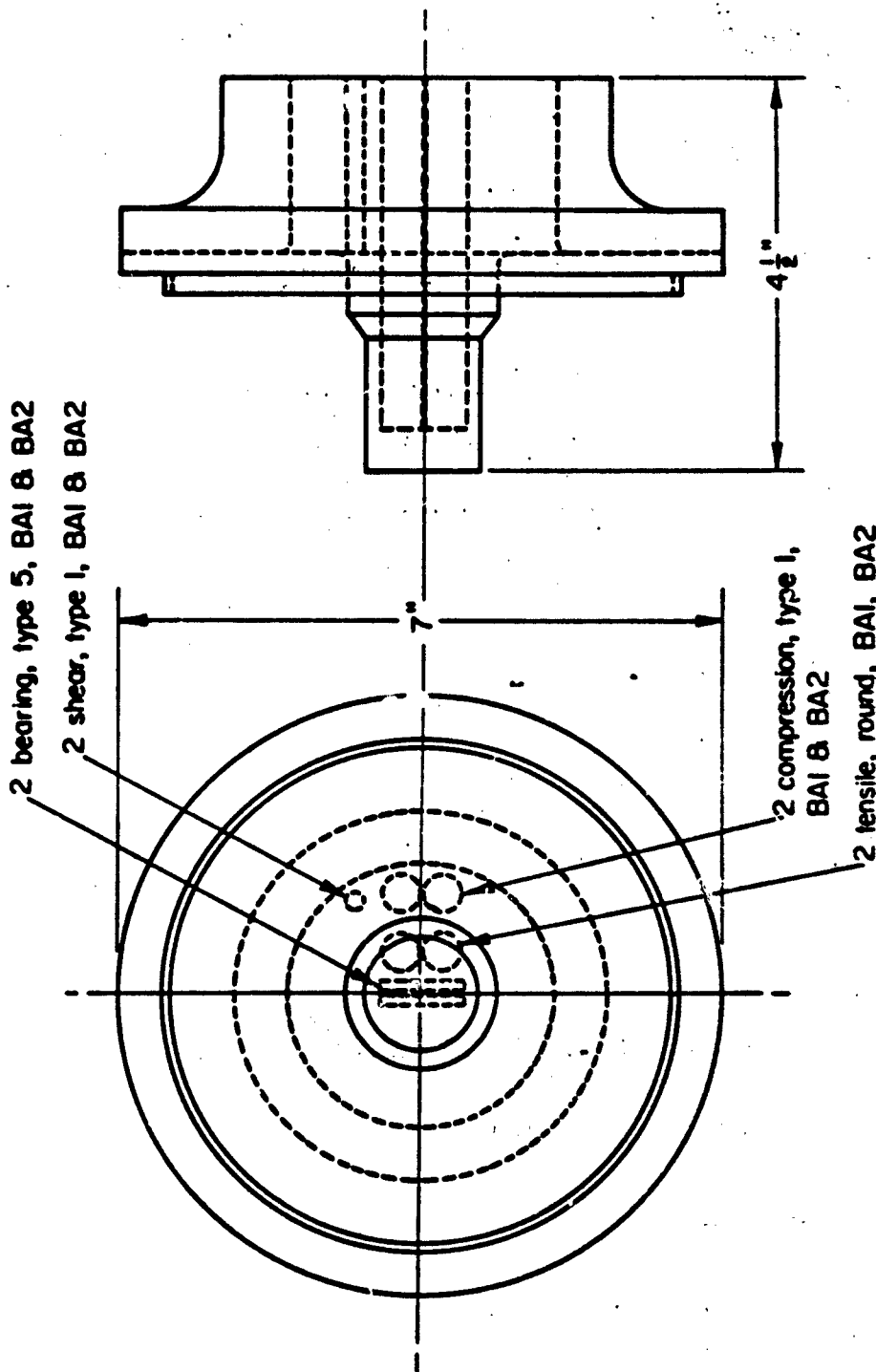

FIGURE 7. LOCATION OF TEST SPECIMENS FOR CASTINGS BA AND BB

Note: Specimens from four similar castings identified as follows:

Filing Marked	Specimen Ident.
46	GAI, GA2, etc
47	GBI, GB2, etc
49	GCI, GC2, etc
50	GDI, GD2, etc

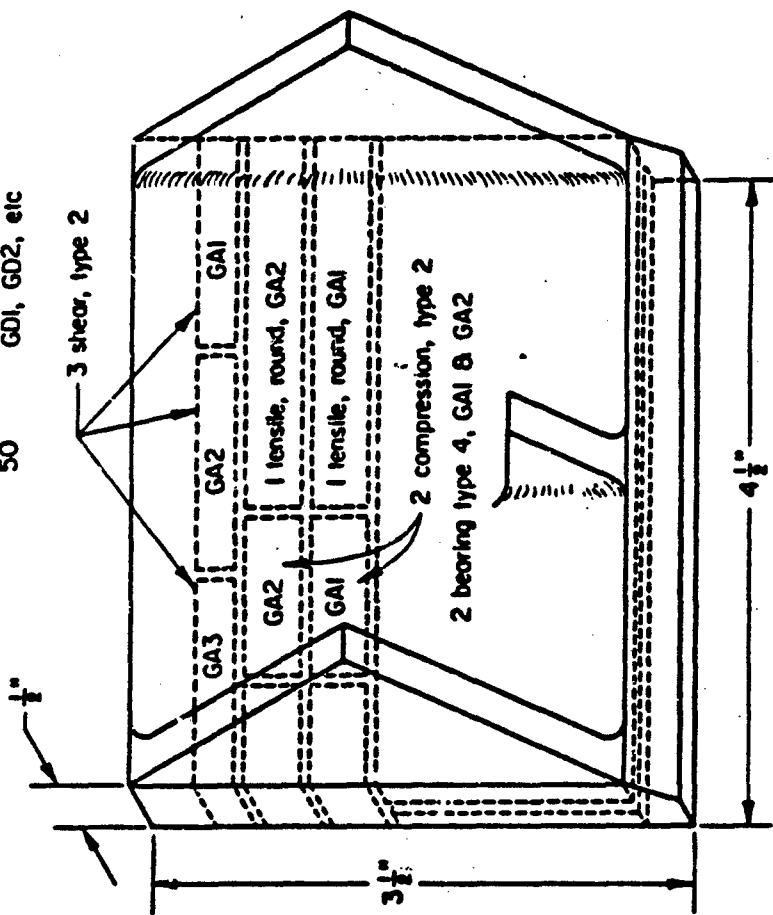

FIGURE 8. LOCATION OF TEST SPECIMENS FOR CASTINGS CA, CB, CC, AND CD

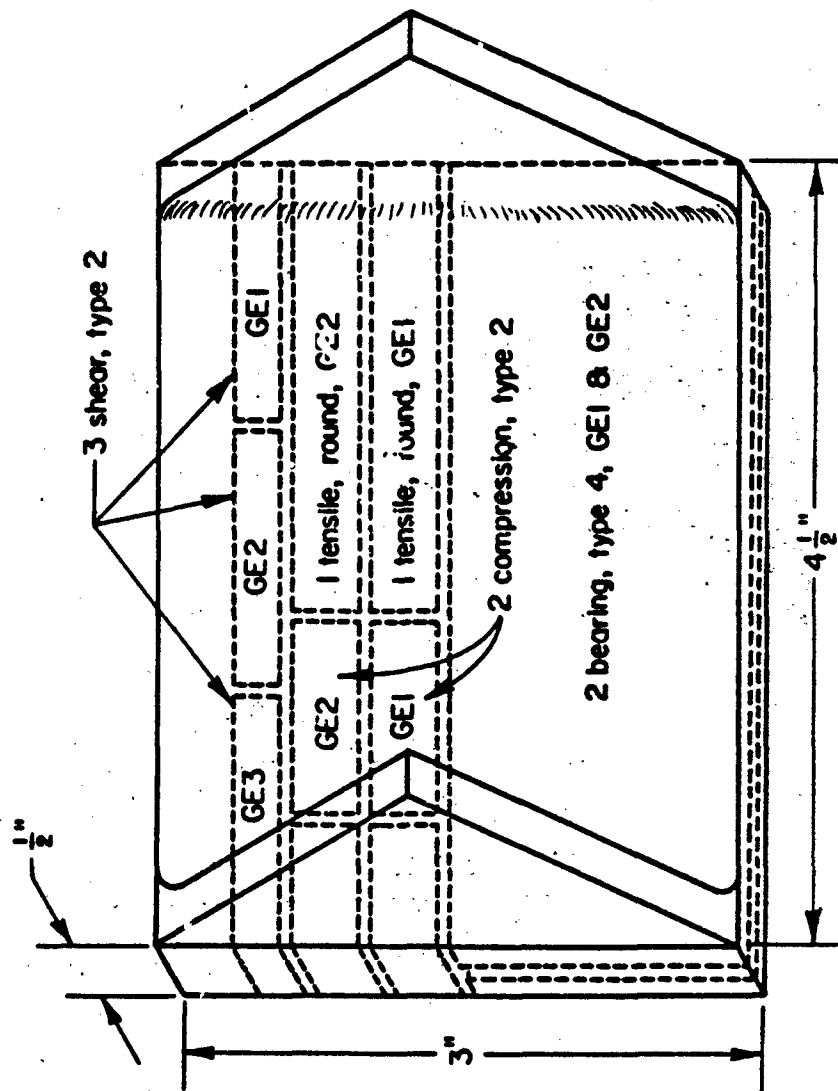

FIGURE 9. LOCATION OF TEST SPECIMENS FOR CASTING GE

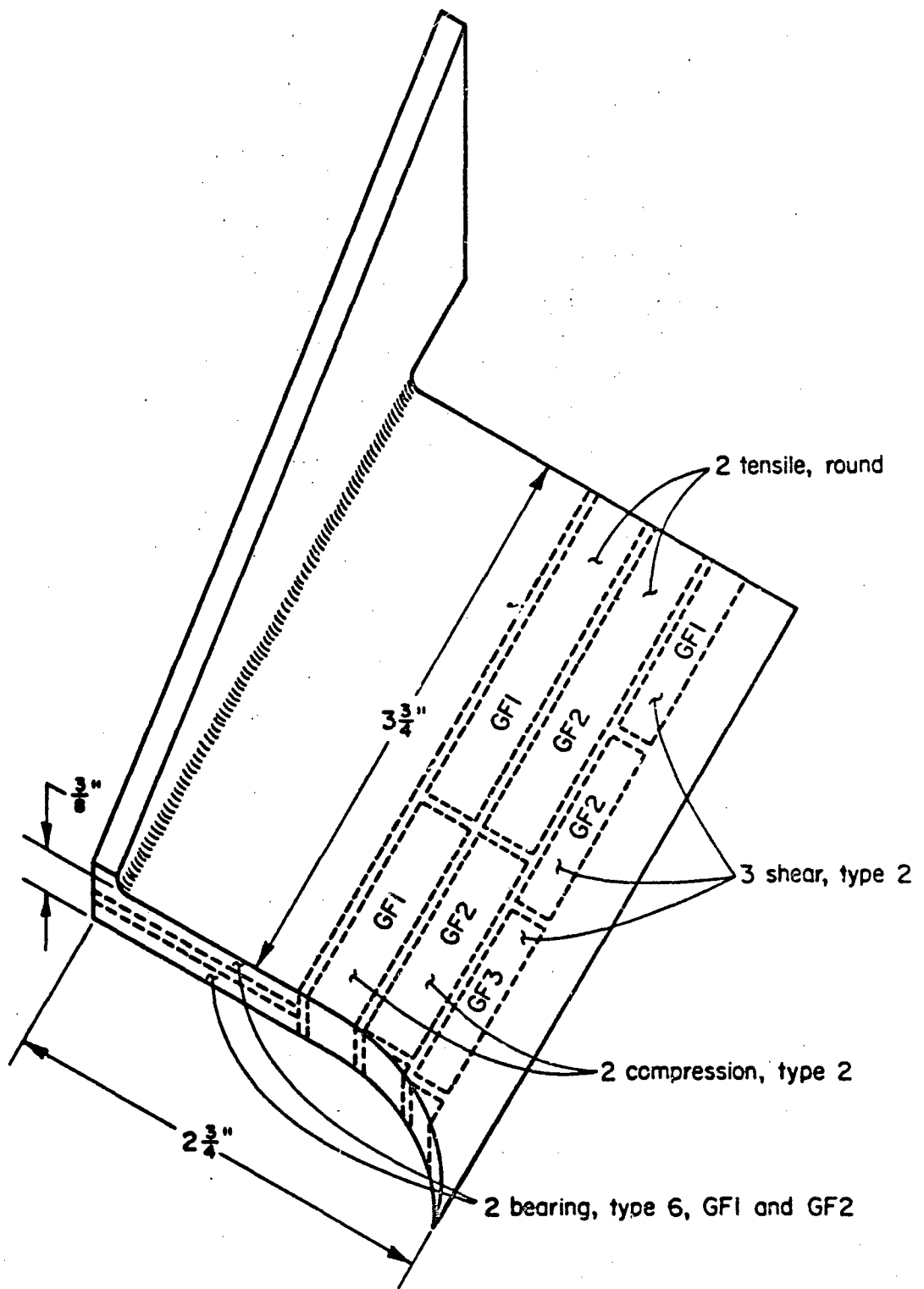

FIGURE 10. LOCATION OF TEST SPECIMENS FOR CASTING GF

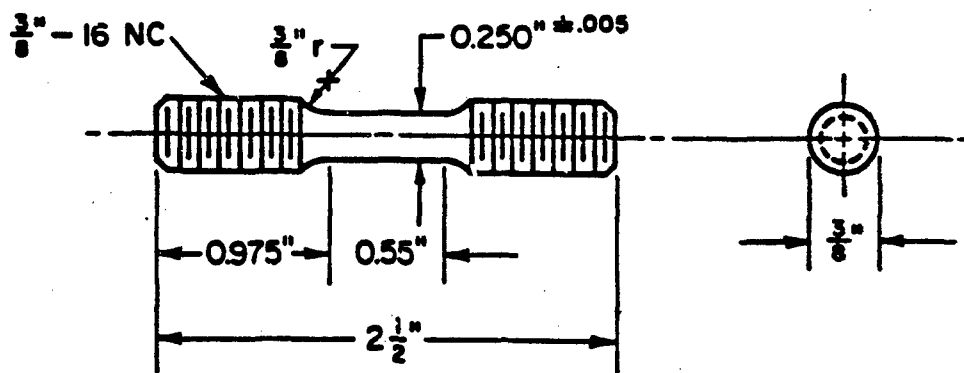

FIGURE 11. ROUND TENSILE SPECIMEN

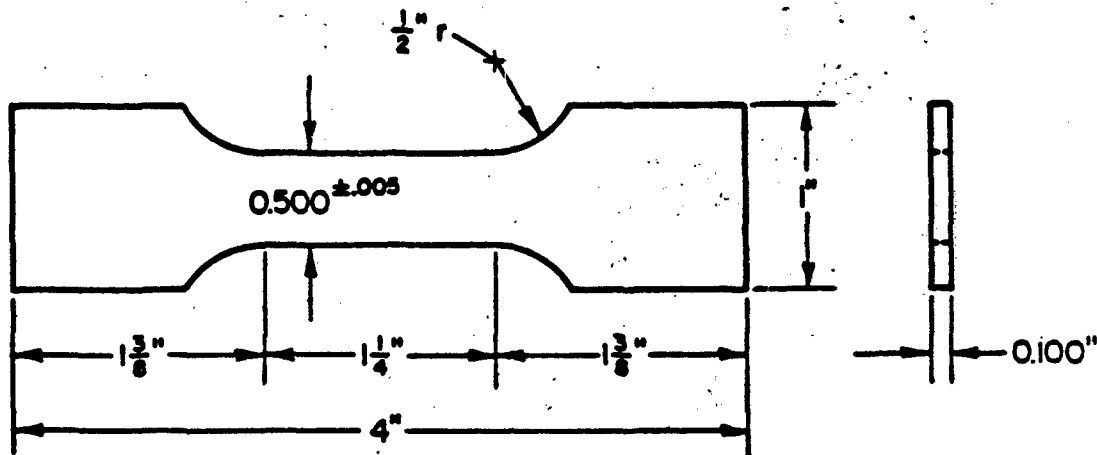
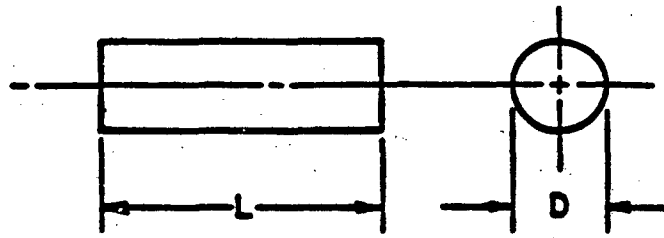

FIGURE 12. FLAT TENSILE SPECIMEN



Note: Ends to be flat and parallel to within 0.0002" of centerline

TYPE	L	D
1	1 1/2"	.500"
2	1"	.313"

FIGURE 13. COMPRESSION SPECIMEN

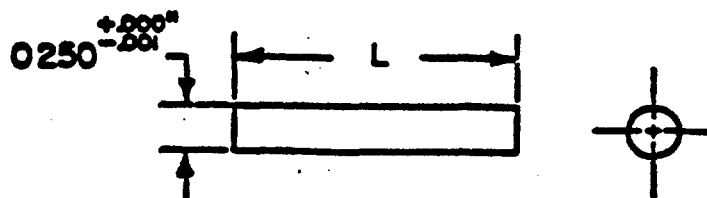

TYPE	L
1	1"
2	1 1/4"
3	1 1/2"

FIGURE 14. SHEAR SPECIMEN

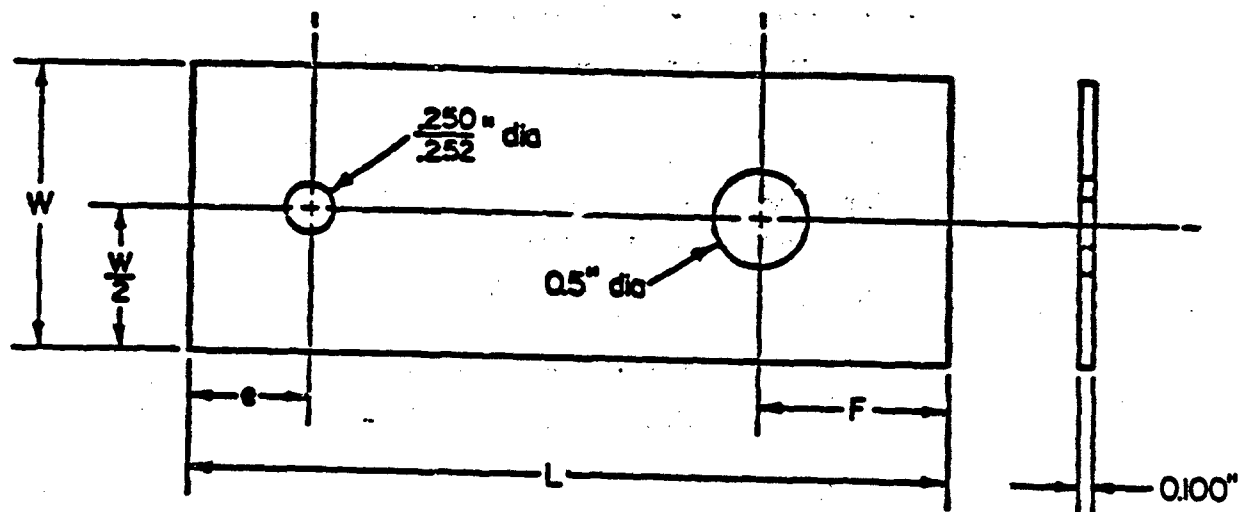

TYPE	W	$e/D = 1.5$	$e/D = 2.0$	F	L
1	1"	.375"	.500"	3/4"	3 3/4"
2	1 1/8"	.375"	.500"	1"	4"
3	1 1/4"	.375"	.500"	1"	4"
4	1 1/2"	.375"	.500"	1"	4"
5	1"	.375"	.500"	1"	4"
6	1 1/2"	.375"	.500"	3/4"	3 3/4"

FIGURE 15. BEARING SPECIMEN

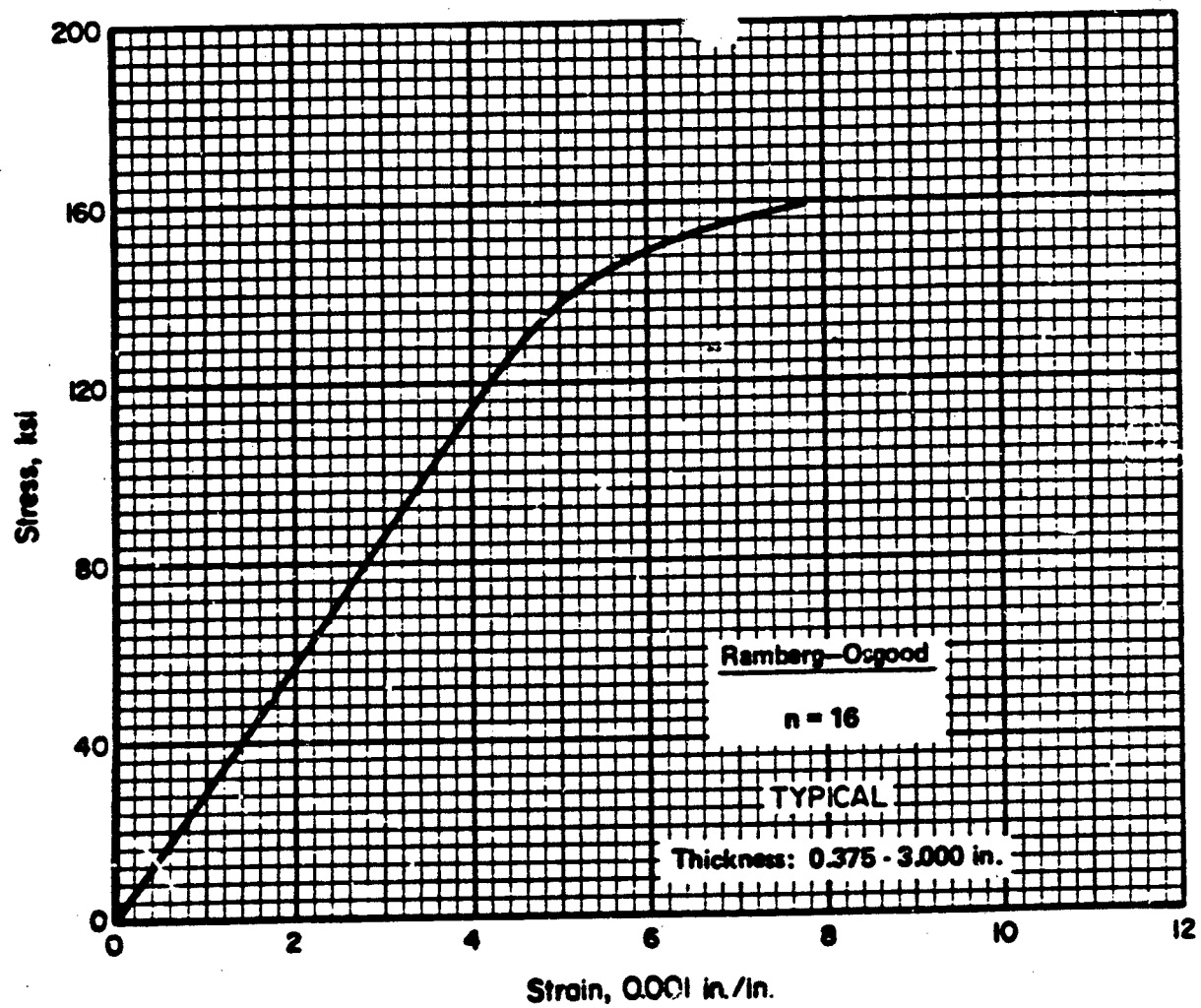

FIGURE 2.6.9.5.6(a). Typical tensile stress-strain curve for 17-4PH (H1000) stainless steel casting at room temperature.

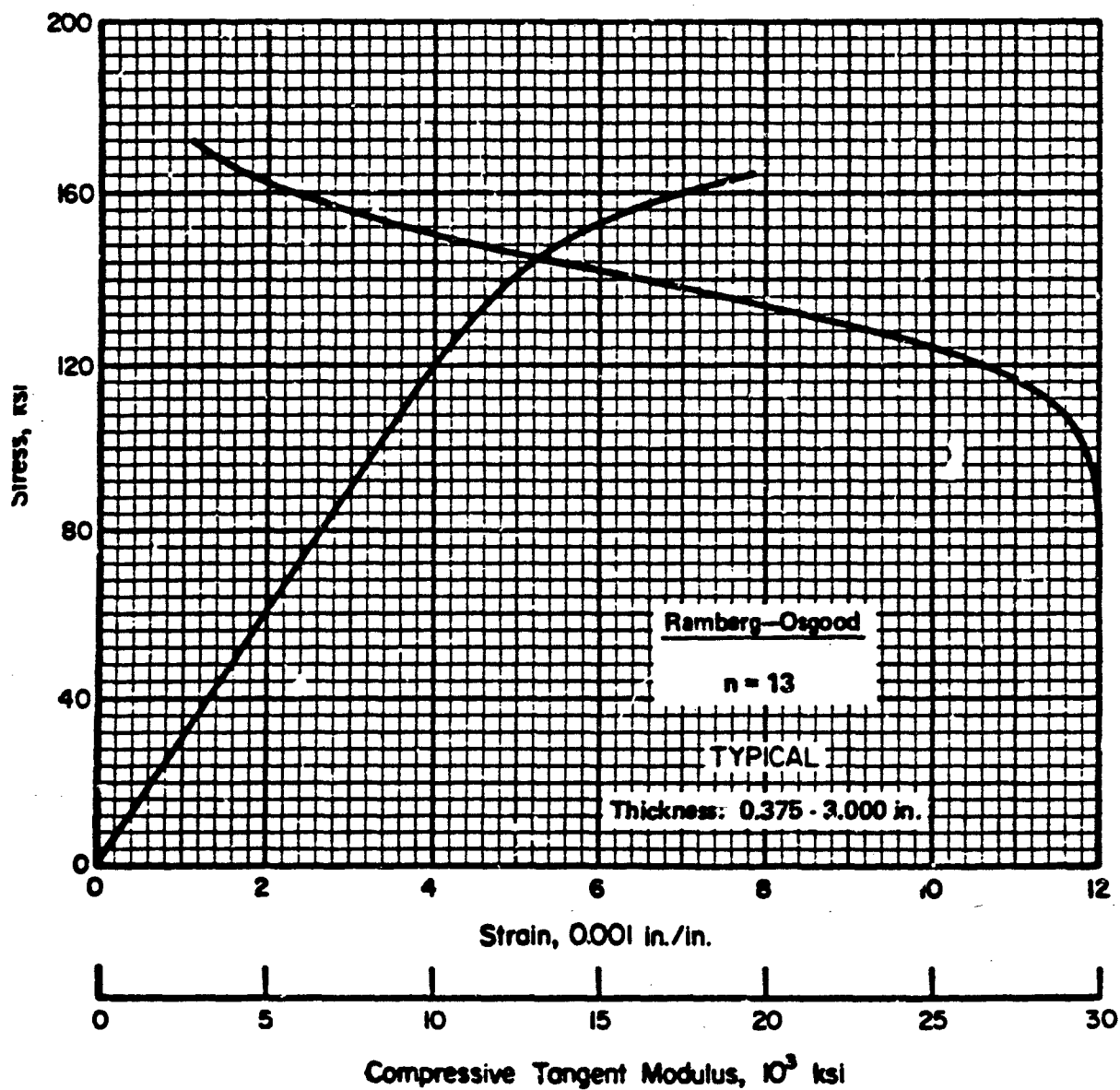

FIGURE 2.6.9.5.6(b). Typical compressive stress-strain and compressive tangent-modulus curves for 17-4PH (H1000) stainless steel casting at room temperature.

END

FILMED

12-84

DTIC