



National Aeronautics and
Space Administration

**NSTS 08307
REVISION A
JULY 6, 1998**

Lyndon B. Johnson Space Center
Houston, Texas 77058

**REPLACES
NSTS 08307
BASELINE**

SPACE SHUTTLE

CRITERIA FOR PRELOADED BOLTS

CONTENTS

NSTS 08307

1.0	INTRODUCTION	1-1
1.1	PURPOSE	1-1
1.2	SCOPE	1-1
2.0	APPLICABLE DOCUMENTS	2-1
3.0	REQUIRED CRITERIA FOR PRELOADED BOLTS	3-1
3.1	INTRODUCTION	3-1
3.2	DEFINITIONS	3-1
	3.2.1 Definition of Terms	3-1
	3.2.2 Definition of Symbols	3-2
	3.2.3 Definition of Application Specific Testing	3-3
3.3	CALCULATION OF THE MAXIMUM AND MINIMUM PRELOADS ...	3-5
3.4	TYPICAL PRELOAD UNCERTAINTIES	3-6
3.5	TYPICAL COEFFICIENTS OF FRICTION/NUT FACTOR	3-7
3.6	EXPECTED PRELOAD LOSS	3-8
3.7	PRELOADED BOLT STRENGTH CRITERIA	3-8
3.8	PLASTIC BENDING	3-10
3.9	PRELOADED BOLT SEPARATION CRITERIA	3-11
3.10	PRELOADED BOLT FATIGUE AND FRACTURE CRITERIA	3-12
3.11	RE-TORQUING OF PRELOADED BOLTS	3-12

1.0 INTRODUCTION

1.1 PURPOSE

The methodology and criteria defined in this document shall be applicable when it is determined that a bolted joint requires preloading to successfully perform its function. Generally, bolts that experience increased axial tensile loads as a result of the applied external load will require preloading to reduce cyclic stresses, prevent pressure leakage, prevent joint separation, or increase system stiffness. This methodology and criteria provides a set of minimum requirements which are adequate, but not overly conservative, so that the design and analysis of preloaded joints are addressed in a consistent and acceptable manner throughout the Space Shuttle Program.

1.2 SCOPE

This document presents a basic, required set of methodology and criteria that each preloaded joint must meet. Also presented are suggested criteria and/or procedures that should be understood and considered in the design and analysis of preloaded joints.

2.0 APPLICABLE DOCUMENTS

The following documents of the date and issue shown form a part of this document to the extent specified herein.

FED-STD-H28

Screw Thread Standards for Federal Services

Ref. Apx. A

3.0 REQUIRED CRITERIA FOR PRELOADED BOLTS

3.1 INTRODUCTION

A preloaded joint must meet (as a minimum) the following three basic requirements:

- a. The bolt must have adequate strength (reference Paragraph 3.7).
- b. The joint must demonstrate a separation factor of safety at limit load. This usually requires that no joint separation occur (reference Paragraph 3.9).
- c. The bolt must have adequate fracture and fatigue life (reference Paragraph 3.10).

Bolt strength is checked at maximum external load and maximum preload, and joint separation is checked at maximum external load and minimum preload. To do this, a conservative estimate of the maximum and minimum preloads must be made, so that no factors of safety are required for these preloads. Safety factors need only be applied to external loads. The criteria specifies how these preloads are to be determined.

3.2 DEFINITIONS

The following are definitions of terms used in the preloaded bolt criteria:

3.2.1 Definition of Terms

- a. **Limit Load.** Limit load is the maximum expected external load a joint will experience during service. Limit load does not include the preload and the positive and negative thermal loads (as defined in this section).
- b. **Axial Load.** An axial load is a load (or component of a load) that is parallel to the bolt's longitudinal axis. An axial load may be either tensile or compressive.
- c. **Yield Load.** Yield load is limit load multiplied by the yield factor of safety.
- d. **Ultimate Load.** Ultimate load is limit load multiplied by the ultimate factor of safety.
- e. **Joint Separation Load (P_{sep}).** Joint separation load is the limit load multiplied by the joint separation factor of safety. The joint separation load must always be greater than or equal to limit load.
- f. **Maximum Preload (PLD_{max}).** The maximum preload is a reasonable estimate of the maximum expected preload in a bolted joint at operating conditions. The maximum preload must be calculated using one of the procedures presented in Paragraph 3.3.

- g. Minimum Preload (PLD_{min}). The minimum preload is a reasonable estimate of the minimum expected preload in a bolted joint at operating conditions. The minimum preload must be calculated using one of the procedures presented in Paragraph 3.3.
- h. Expected Preload Loss (P_{loss}). The expected preload loss is an estimate of the decrease in the preload of a bolted joint due to permanent set during service. The preload loss term must meet the requirements of Paragraph 3.6.
- i. Prevailing Torque (T_p). The prevailing torque is a torque that is independent of the preload level, and is due to some feature such as a self-locking nut.
- j. Positive/Negative Thermal Load. The positive thermal load (P_{thr}^{pos}) is the thermally induced load that increases the preload, and the negative thermal load (P_{thr}^{neg}) is the thermally induced load that decreases the preload. These two thermal loads refer only to the axial load caused by a difference in the coefficients of thermal expansion of the bolt and joint, and/or a difference in the temperature between the bolt and joint.
- k. Initial Torque-Yield. Initial torque-yield is the initial yield of a bolted joint in which the bolt is in the process of being torqued. Initial torque-yield is usually due, in part, to the torquing process.

3.2.2 Definition of Symbols

a. External/Internal Loads:

P = External axial load applied to joint at bolt location due to application of limit load to the structure

P_b = Bolt axial load resulting from yield, ultimate or joint separation load

V = Bolt shear load resulting from limit load

M = Bolt bending moment resulting from limit load

b. Factors of Safety:

SF = Bolt strength factor of safety

SF_{sep} = Joint separation factor of safety

c. Allowables/Strengths:

PA_t = Axial load allowable of bolt due to tension

PA_s = Axial load allowable of bolt or nut due to thread shear

VA = Shear load allowable of bolt

MA = Bending load allowable of bolt

d. Geometric Properties/Constants:

D = Basic major diameter of external threads (bolt)

E = Basic pitch diameter of external threads (bolt)

K_b = Stiffness of bolt

K_j = Stiffness of joint

n = Loading-plane factor (see Figure 3-1)

n_o = Threads/inch

R_o = Outer radius of torqued element (nut or head)

R_i = Inner radius of torqued element (nut or head)

R_t = Effective radius of thread forces
= $1/2 \times E$. . . approximately

R_e = Effective radius of torqued element-to-joint bearing forces
= $1/2 \times (R_o + R_i)$

α = Thread lead angle
= $\tan^{-1} [1/(n_o\pi E)]$. . . for unified thread form

β = Thread half angle
= 30° . . . for unified thread form

\emptyset = Load factor
= $K_b/(K_b + K_j)$

π = 3.1415927

NOTE: n and \emptyset can be determined by analysis or tests.

3.2.3 Definition of Application Specific Testing

Application specific testing refers to test conditions that closely resemble the actual configuration. Minimally, an application specific test must include the following items:

a. Torque-Preload Tests:

1. Same lubricants

2. Same thread form
 3. Same bolt diameter
 4. Same type/size of torqued element (nut or bolt head)
 5. Same joint configuration
 - (a) Thickness
 - (b) Material(s)
 - (c) Surface finish
 - (d) Washer(s)
 - (e) Nut/nutplate/insert
 6. Same torque method
 - (a) Approximately the same type of torque wrench
 - (b) Torqued from same element (bolt head or nut)
- b. Preload Loss Tests:
1. Same preload level
 2. Same length of thread engagement
 3. Same bolt head and nut type/size/material
 4. Same bolt diameter
 5. Same joint configuration
 - (a) Material(s)
 - (b) Surface finish
 - (c) Washer(s)
 - (d) Number of joint interfaces
 6. Same angle between bolt head/nut and joint interface

A valid application specific test must include an adequate sample and an acceptable statistical analysis. The application specific test and data reduction are subject to review and approval by the appropriate NASA center. In addition, other test results

and/or an experience base, which does not adhere to the strict definition of application specific testing, may be substituted for this application specific testing if approved by the appropriate NASA center.

3.3 CALCULATION OF THE MAXIMUM AND MINIMUM PRELOADS

The bolt strength criteria, the bolt fatigue and fracture criteria, and the joint separation criteria do not require that the preload be multiplied by yield, ultimate or joint separation factors of safety, yet any uncertainty in the preload must be taken into account. This is done by defining a maximum preload (PLD_{max}) and a minimum preload (PLD_{min}).

The maximum and minimum preloads must be calculated using one of the following three procedures (Procedure A, Procedure B or Procedure C). The procedure chosen must be appropriate for the specific application.

- a. Procedure A. If the preload is achieved by measuring the applied torque without torquing to initial torque-yield, the maximum and minimum preloads must be calculated using one of the following two methods (Typical Coefficient Method or Experimental Coefficient Method).
 1. Typical Coefficient Method. The following four items must be included in the calculation of the maximum and minimum preloads:
 - (a) The maximum and minimum torques of the specified torque-range plus any prevailing torque (T_{max} , T_{min} and T_p).
 - (b) The uncertainty (Γ) for torque measurement as listed in Paragraph 3.4.
 - (c) The typical coefficient of friction at the external-to-internal thread interface (μ_t^{typ}) and the nut-to-joint bearing interface (μ_b^{typ}) OR the typical nut factor (K^{typ}). The typical coefficients of friction and the typical nut factor must meet the requirements of Paragraph 3.5.
 - (d) The positive and negative thermal loads (P_{thr}^{pos} and P_{thr}^{neg}).

The maximum and minimum preloads must be calculated using the following equations:

$$PLD_{max} = (1 + \Gamma)T_{max}/[R_t (\tan\alpha + \mu_t^{typ}/\cos\beta) + R_e\mu_b^{typ}] + P_{thr}^{pos}$$

$$PLD_{min} = (1 - \Gamma) (T_{min} - T_p)/[R_t (\tan\alpha + \mu_t^{typ}/\cos\beta) + R_e\mu_b^{typ}] + P_{thr}^{neg} - P_{loss}$$

OR

$$PLD_{max} = (1 + \Gamma)T_{max}/K^{typ}D + P_{thr}^{pos}$$

$$PLD_{min} = (1 - \Gamma) (T_{min} - T_p)/K^{typ}D + P_{thr}^{neg} - P_{loss}$$

2. Experimental Coefficient Method. The use of the uncertainty factor can be avoided if application specific testing is done to determine μ_t , μ_b and K . Here both the maximum and minimum values of these coefficients must be determined. The maximum and minimum preloads are calculated as follows:

$$PLD_{\max} = T_{\max}/[R_t (\tan\alpha + \mu_t^{\min}/\cos\beta) + R_e\mu_b^{\min}] + P_{\text{thr}}^{\text{pos}}$$

$$PLD_{\min} = T_{\min} - T_p/[R_t (\tan\alpha + \mu_t^{\max}/\cos\beta) + R_e\mu_b^{\max}] + P_{\text{thr}}^{\text{neg}} - P_{\text{loss}}$$

OR

$$PLD_{\max} = T_{\max}/K^{\min}D + P_{\text{thr}}^{\text{pos}}$$

$$PLD_{\min} = (T_{\min} - T_p)/K^{\max}D + P_{\text{thr}}^{\text{neg}} - P_{\text{loss}}$$

- b. Procedure B. If the preload is achieved by torquing the bolt to initial torque-yield, the maximum and minimum preloads must be determined from an application specific test. The torque wrench must be designed to detect initial torque-yield of the bolt and the test wrench must have the same accuracy as the wrench used on the actual hardware.
- c. Procedure C. If the preload is achieved by any means other than torque measurement or torquing to initial torque-yield, the following four items must be included in the calculation of the maximum and minimum preloads:
1. The maximum and minimum values of any specified tolerance band placed upon the preload. ($PLD_{\pm TOL}$)
 2. The appropriate uncertainty (Γ) in the measurement system as listed in Paragraph 3.4.
 3. The positive and negative thermal loads ($P_{\text{thr}}^{\text{pos}}$ and $P_{\text{thr}}^{\text{neg}}$).
 4. The expected preload loss (P_{loss}).

The maximum and minimum preloads must be calculated using the following equation:

$$PLD_{\max} = (1 + \Gamma) (PLD + TOL) + P_{\text{thr}}^{\text{pos}}$$

$$PLD_{\min} = (1 - \Gamma) (PLD - TOL) + P_{\text{thr}}^{\text{neg}} - P_{\text{loss}}$$

3.4 TYPICAL PRELOAD UNCERTAINTIES

If the Typical Coefficient Method is used to determine the maximum and/or the minimum preload, the following preload uncertainties (Γ) can be used. Other values may be used

when substantiated by an application specific test. If, for example, a particular lubricant demonstrates a typical uncertainty of $\pm 35\%$ in an application specific torque-preload test, the uncertainty that must be used is $\pm 35\%$. The uncertainty and the application specific test are subject to review and approval by the appropriate NASA center.

These uncertainties shall be used for small fasteners. Application specific testing is required for large fasteners. In general, a fastener is considered large if it has a diameter $\geq 3/4"$. This determination, however, shall be made with the approval of the appropriate NASA center.

a. Torque-measurement:

- | | |
|---|---------------------|
| 1. Torque-measurement of unlubricated bolts | $\Gamma = \pm 35\%$ |
| 2. Torque-measurement of cad-plated bolts | $\Gamma = \pm 30\%$ |
| 3. Torque-measurement of lubricated bolts | $\Gamma = \pm 25\%$ |

b. Other methods:

- | | |
|-----------------------------------|---------------------|
| 1. Hydraulic tensioners | $\Gamma = \pm 15\%$ |
| 2. Preload indicating washers | $\Gamma = \pm 10\%$ |
| 3. Ultrasonic measurement devices | $\Gamma = \pm 10\%$ |
| 4. Bolt elongation measurement | $\Gamma = \pm 5\%$ |
| 5. Instrumented bolts | $\Gamma = \pm 5\%$ |

NOTE: If the bolt is torqued from the head, application specific testing to determine the preload is strongly recommended. Typical uncertainty may also be determined this way. If experience and/or test data justifies it, however, an additional uncertainty may simply be added to the above typical preload uncertainties. This method must be justified to, and approved by, the appropriate NASA center.

If the preload is determined by a method not listed above, an uncertainty typical of that device must be used. The uncertainty must include not only the actual stated uncertainty of the device, but also a typical uncertainty which results from such things as operator error, unexpected variations in geometry, etc.

3.5 TYPICAL COEFFICIENTS OF FRICTION/NUT FACTOR

The typical coefficients of friction must be typical of the type of bolt-to-joint interfaces used in the specific application. The parameters that must be considered in selecting a typical coefficient of friction are the following:

- a. Material at the bolt-to-joint interfaces.
- b. Surface finish at the bolt-to-joint interfaces.
- c. Lubricants at the bolt-to-joint interfaces.

The typical nut factor must be typical of the type of bolt-to-joint interfaces used in the specific application. In addition, the nut factor must also be typical of the type and size of nut (or bolt head) used in the specific application. The parameters that must be considered in selecting a typical nut factor are the following:

- a. Material at the bolt-to-joint interfaces.
- b. Surface finish at the bolt-to-joint interfaces.
- c. Lubricants at the bolt-to-joint interfaces.
- d. Nut (or bolt head) type and size.

3.6 EXPECTED PRELOAD LOSS

Most preloaded joints experience some amount of preload loss, due to plastic deformation (permanent set) and/or vibration. This criteria does not address preload loss due to vibration, as some method of preventing the nut and/or bolt from vibrating loose should be part of the basic design of the joint.

Preload loss can vary between about 2% and 10% of the actual preload level in the bolt. This section does not require that the preload loss be calculated by a particular method. However, preload loss must be considered in the analysis of preloaded joints and, if a joint is configured such that its stiffness is primarily dependent upon nonmetallic materials, or if it does not have metal-to-metal contact throughout, the preload loss must be determined from an application specific test.

An acceptable method of calculating the preload loss in joints that have metal-to-metal contact throughout their thickness is the following:

$$\begin{aligned}
 P_{\text{loss}} &= 5\% \text{ of the maximum preload} \\
 &= .05 \times \text{PLD}_{\text{max}}
 \end{aligned}$$

3.7 PRELOADED BOLT STRENGTH CRITERIA

This section addresses both yield load analysis and ultimate load analysis. Yield factors of safety and allowables are used during a yield load analysis, and ultimate factors of safety and allowables are used during an ultimate load analysis. The bolt shall not yield in the minimum cross-section at yield load and shall not fail at ultimate load.

Localized yielding of the threads is allowed at yield load if this deformation is not detrimental to the system.

The load equations presented in this section are based on simple linear preloaded joint theory. A more accurate, detailed analysis (linear or nonlinear) may be used instead of the simple linear equations to determine an axial bolt load (P_b), a shear bolt load (V), and/or a bending bolt load (M). The analysis, however, must include the maximum pre-load (PLD_{max}) and apply factors of safety to limit load only. The analysis is subject to review and approval by the appropriate NASA center.

The strength section of the criteria is divided into four categories that reflect the types of load a preloaded bolt can experience. The four categories are: (1) axial load, (2) shear load, (3) bending load, and (4) combined axial, shear and/or bending load. Regardless of the type of analysis, the bolt must meet the criteria presented in each applicable category.

The strength criteria must also include a condition of no detrimental yielding during installation of a bolt. This must include the effects of the axial load due to the preload in combination with the shear due to the torquing. The bolt, bolt threads and the nut must be checked.

The axial bolt load is calculated using the following equation: (unless a more accurate, detailed analysis is performed)

$$P_b = PLD_{max} + n\phi (SF \times P)$$

NOTE: The stiffness parameter (ϕ) and the loading-plane factor (n) may be determined either by analysis or an application specific test.

a. Axial Load. The axial load allowables (PA_t and PA_s) must be known quantities and are usually given by the manufacturers or can be looked up. A suggested method of calculating them for UNF bolts is given in Appendix A.

1. Minimum Cross-Section of Bolt. The bolt must satisfy the following two criteria:

$$\text{Criterion 1: } MS = PA_t / (SF \times P) - 1 \geq 0$$

$$\text{Criterion 2: } MS = PA_t / P_b - 1 \geq 0$$

2. Shear Pull-Out of Threads. If an internal thread (nut, nutplate, tapped hole, etc.) is used that is not guaranteed to develop the full ultimate load capability of the bolt, or if the internal thread is not fully threaded onto the bolt, the following two criteria must be met:

$$\text{Criterion 1: } MS = PA_s / (SF \times P) - 1 \geq 0$$

$$\text{Criterion 2: } MS = PA_s / P_b - 1 \geq 0$$

NOTE: These two criteria need only be checked at ultimate load.

b. Shear Load:

$$MS = VA / (SF \times V) - 1 \geq 0$$

c. Bending Load:

$$MS = MA / (SF \times M) - 1 \geq 0$$

d. Combined Axial, Shear and/or Bending Load:

If the bolt is subject to a combination of loads, the following relationship must hold true for both maximum and minimum preload.

$$(R_a + R_b/K)^2 + R_s^3 \leq 1$$

$$1 \leq K \leq K_y$$

Where

$$K_y = 1.0 \text{ for minimum preload}$$

K_y = A plastic bending factor based on actual material stress-strain curves and calculated such that permanent strains do not exceed 0.2% for maximum preload

R_a = Ratio of axial load to axial load allowable and is chosen as the maximum of

$$(SF \times P) / PA_t ; P_b / PA_t ; PLD_{max} / PA_t$$

R_b = Ratio of bending load to bending load allowable,
= $(SF \times M) / MA$

R_s = Ratio of shear load to shear load allowable,
= $(SF \times V) / VA$

NOTE: The axial and shear load allowables (PA_t and VA) in this interaction equation are based on the cross-section at which the combined loads occur.

3.8 PLASTIC BENDING

If the criteria of Paragraph 3.7c or 3.7d cannot be met, but the resulting permanent deformation will be acceptable, it will be permissible to use a plastic bending theory to

determine the margins of safety. For a sufficiently ductile material, the following criteria may be used:

a. Bending Load:

$$MS = (MA \times K_p)/(SF \times M) - 1 \geq 0$$

Where K_p is a plastic bending factor

b. Combined Axial, Shear and/or Bending Load:

If the bolt is subject to a combination of loads, the following relationship must hold true:

$$R_a^2 + R_b + R_s^3 \leq 1$$

Where R_a and R_s are the same as before and

$$R_b = (SF \times M)/(MA \times K_p)$$

A more exact plastic analysis can be done by using the actual material stress-strain curve. For a material with limited ductility this must be done if plastic bending is to be used.

3.9 PRELOADED BOLT SEPARATION CRITERIA

Separation of a preloaded joint must not occur below the joint separation load. The equations presented in this section are based on simple linear preloaded joint theory. A more accurate, detailed analysis may be used instead of the simple linear equations to determine if joint separation occurs. The analysis, however, must use the minimum preload (PLD_{min}) and the joint separation load (P_{sep}). If the bolt is loaded above its yield allowable at the joint separation load, the analysis must also be nonlinear. Based on this analysis, joint separation must not occur below the joint separation load. The analysis is subject to review and approval by the appropriate NASA center.

The criteria states that joint separation must not occur below the joint separation load. This requirement may not always be realistic. For hardware such as that which is part of a pressure system and/or maintains hazardous material, complex preloaded joint/seal designs are generally used. To prevent leakage in such a design, every structural element should be treated as critical. Therefore, the joint/seal/fastener system must be carefully analyzed and the interaction of the individual components accounted for. In these cases the system must demonstrate a separation safety factor (SF_{sep}) while using the minimum preload (P_{min}) on all fasteners. The use of torque measuring devices is not recommended with these system designs unless adequate analysis and/or testing procedures demonstrate acceptability. The analysis that demonstrates a joint separation factor of safety, must be approved by the appropriate NASA center.

Unless a more accurate, detailed analysis is performed, the following equation is used to determine which joint separation case (Case 1 or Case 2) is applicable:

$$P_b = PLD_{\min} + n\theta P_{\text{sep}}$$

Where

$$P_{\text{sep}} = P \times SF_{\text{sep}}$$

NOTE: The stiffness parameter (θ) and the loading-plane factor (n) may be determined either by analysis or an application specific test.

- a. Case 1. For $P_b \leq$ the tensile yield allowable of the bolt (based on the minimum cross-sectional area), the following separation criteria must be met:

$$MS = PLD_{\min} / [(1-n\theta) P_{\text{sep}}] - 1 \geq 0$$

- b. Case 2. For $P_b >$ the tensile yield allowable of the bolt (based on the minimum cross-sectional area), a nonlinear analysis must be performed to determine if joint separation occurs. The nonlinear analysis must be based on the actual stress-strain curve of the bolt's material, and must use the minimum preload (PLD_{\min}) and the joint separation load (P_{sep}). Based on the nonlinear analysis, joint separation must not occur below the joint separation load.

3.10 PRELOADED BOLT FATIGUE AND FRACTURE CRITERIA

All preloaded bolts must be assessed for fatigue life. Bolt thread stress concentrations should be accounted for in cycle life calculations. Factors on both the stress magnitude (f_m) and on life (f_l) shall be applied. The factor f_m is to account for uncertainties in calculated stress magnitude and shall be no less than one. The factor f_l is a scatter factor that should be based on the material used in the bolt. The values used for these factors is subject to the approval of the appropriate NASA center.

Bolts used in hardware that is under fracture control must meet fracture control requirements in accordance with their hardware's fracture control plan. Bolts under a fracture control program whose singular failure could result in loss of life or loss of a critical system must be shown to be safe-life by fracture mechanics analysis, must be non-destructively inspected or proof tested prior to installation. Some form of traceability of these bolts must be maintained in order to guarantee that only bolts which have passed inspection or proof testing are installed.

3.11 RE-TORQUING OF PRELOADED BOLTS

Re-torquing of preloaded bolts using torque measurements as the means of determining the preload often results in unexpected preload values. If torque measurements

are used to determine the preload in bolts which have undergone one or more installation cycles, application specific testing is required. Direct measurement or any method that does not rely on torque measurement may also be used to determine the preload in a bolt that has experienced one or more installation cycles.

An installation cycle is defined as a procedure which produces a positive torque (increases preload) and then subsequently a negative torque (decreases preload) on a bolt. A preloaded bolt is in its first installation cycle until it is subject to a negative torque for the first time. For example, a bolt that has lost preload due to relaxation but has not been subject to a negative torque may be re-torqued and still considered to be in its first installation cycle.

FIGURE 3-1
DEFINITION OF THE LOADING-PLANE FACTOR

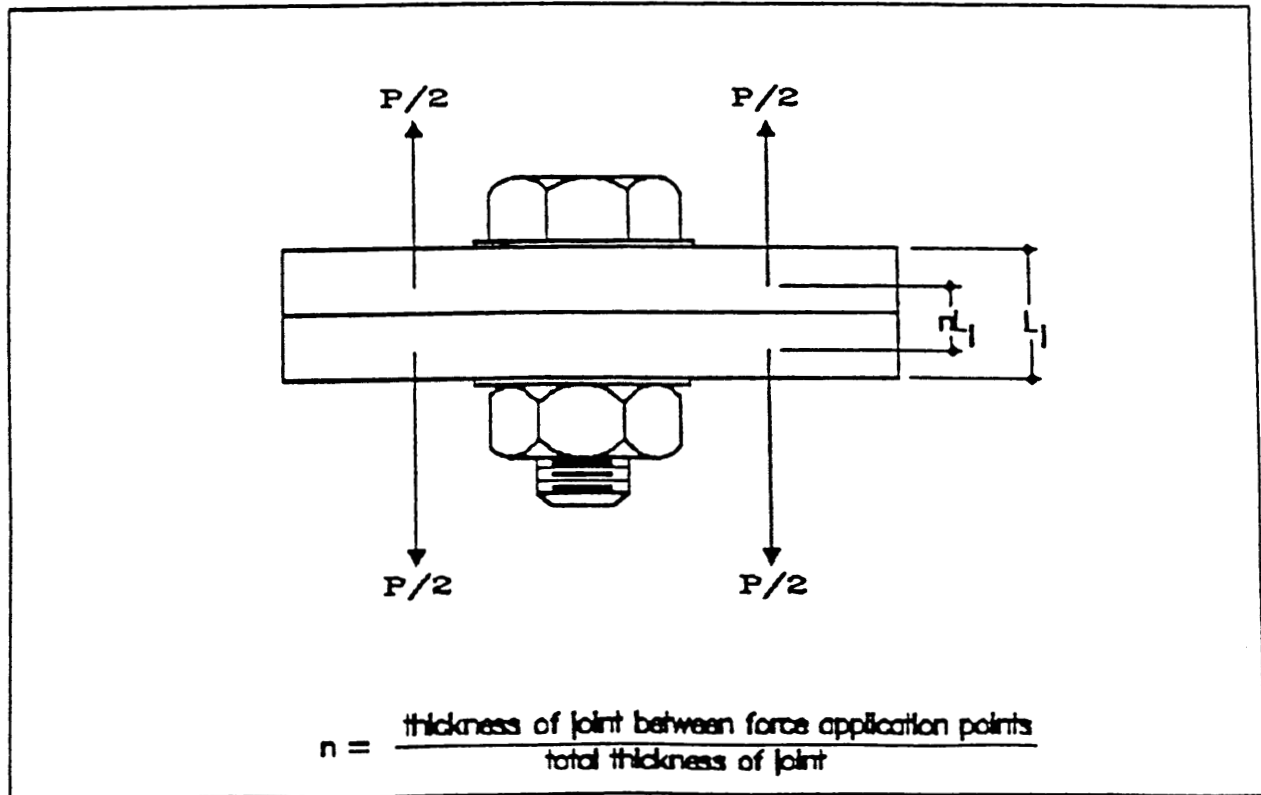

APPENDIX A

BOLT AXIAL LOAD ALLOWABLES

The equations presented in this section apply to the unified thread form (all classes of fit). If a different thread form is used, equivalent equations must be developed for that thread form. The following symbol definitions apply specifically to this section.

A_t - Tensile area of bolt

A_{se} - Shear area of external threads

A_{si} - Shear area of internal threads

D_e - Major diameter of external threads

D_i - Major diameter of internal threads

E_e - Pitch diameter of external threads

E_i - Pitch diameter of internal threads

F_{ty} - Minimum tensile yield strength of bolt

F_{tu} - Minimum tensile ultimate strength of bolt

F_{su} - Minimum shear ultimate strength of bolt or nut

G_e - Allowance on external threads

K_e - Minor diameter of external threads

K_i - Minor diameter of internal threads

L_e - Length of thread engagement

P_{se} - External thread shear load allowable

P_{si} - Internal thread shear load allowable

TD_x - Tolerance on major diameter of external/internal threads

TE_x - Tolerance on pitch diameter of external/internal threads

TK_x - Tolerance on minor diameter of external/internal threads

bsc - Modifier denoting the basic value

max - Modifier denoting the maximum value

min - Modifier denoting the minimum value

Two axial load allowables are referenced in this criteria. The tensile axial load allowable (PA_t) is based on the minimum cross-sectional area of the bolt and is a measure of the ability of the main body of the bolt to withstand load. The thread shear axial load allowable (PA_s) is based on the smaller of the two thread shear load allowables.

1.0 AXIAL LOAD ALLOWABLE DUE TO TENSION

If a minimum ultimate tensile load is given for a bolt, the axial load allowables are calculated as follows:

- a. Yield

$$PA_t = (F_{ty}/F_{tu}) \times \text{minimum ultimate tensile load}$$

- b. Ultimate

$$PA_t = \text{minimum ultimate tensile load}$$

If a minimum ultimate tensile load is not given for a bolt, the axial load allowables must be determined from testing or calculated using the following equations:

- a. Yield

$$PA_t = A_t \times F_{ty}$$

- b. Ultimate

$$PA_t = A_t \times F_{tu}$$

The tensile stress area of the bolt (A_t) must be based on the minimum cross-sectional area of the bolt. If the threaded section of a bolt is the location of the minimum cross-section, the tensile stress area of the bolt may be based on the basic minor diameter of the external threads or calculated using the following equation:

a. $A_t = 0.7854(D_e^{b_{sc}} - 0.9743/n_o)^2$

2.0 AXIAL LOAD ALLOWABLE DUE TO THREAD SHEAR

The axial load allowable due to thread shear is the smaller of the external thread shear load allowable (P_{se}) and the internal thread shear load allowable (P_{si}). These two allowables are calculated as follows:

a. $P_{se} = A_{se} \times (F_{su})$ bolt

b. $P_{si} = A_{si} \times (F_{su})$ nut

The two thread shear areas are calculated using the following equations:

a. $A_{se} = \pi L_e K_i^{\max} [0.750 - 0.57735 n_o (TK_i + TE_e + G_e)]$

b. $A_{si} = \pi L_e D_e^{\min} [0.875 - 0.57735 n_o (TD_e + TE_i + G_e)]$

NOTE: The equations for the tensile stress area and the thread shear areas were taken from FED-STD-H28, Screw Thread Standards for Federal Services, issued by the United States Department of Commerce, National Bureau of Standards.