

# System Engineering "Toolbox" for Design-Oriented Engineers

---

*B.E. Goldberg, K. Everhart, R. Stevens,  
N. Babbitt III, P. Clemens, and L. Stout*

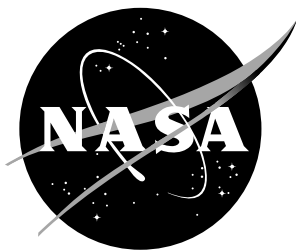

# System Engineering "Toolbox" for Design-Oriented Engineers

---

*B.E. Goldberg  
Marshall Space Flight Center • MSFC, Alabama*

*K. Everhart, R. Stevens, N. Babbitt III,  
P. Clemens, and L. Stout  
Sverdrup Technology, Inc.*



## ACKNOWLEDGMENTS

The authors are very grateful for the help received from the following persons in producing this document. Becky Mohr contributed information and illustrations concerning preliminary hazard analyses and failure modes and effects analyses. Bryan Bachman provided a thorough review of drafts of the entire document. Larry Thomson prepared a figure in the system safety and reliability tools section. Jimmy Howell verified all numerical calculations in the examples. The following persons reviewed the indicated sections of this document and offered suggestions that greatly enhanced the discussions of the tools and methodologies presented:

Bill Cooley	Design-Related Analytical Tools
Melissa Van Dyke	Trend Analysis Tools
Karl Knight	System Safety and Reliability Tools
Charles Martin	Statistical Tools and Methodologies Graphical Data Interpretation Tools
Ben Shackelford	Case Study

**Figures provided courtesy of Sverdrup Technology, Inc., Tullahoma, Tennessee.**

Figure 3-1	Figure 3-21
Figure 3-2	Figure 3-22
Figure 3-3	Figure 3-23
Figure 3-4	Figure 3-24
Figure 3-5	Figure 3-25
Figure 3-6	Figure 3-26
Figure 3-7	Figure 3-27
Figure 3-8	Figure 3-28
Figure 3-9	Figure 3-29
Figure 3-10	Figure 3-30
Figure 3-11	Figure 3-31
Figure 3-12	Figure 3-32
Figure 3-15	Figure 3-33
Figure 3-16	Figure 3-34
Figure 3-17	Figure 3-35
Figure 3-18	Figure 3-36
Figure 3-19	Figure 3-40
Figure 3-20	Figure 3-41

## TABLE OF CONTENTS

	Page
1. INTRODUCTION .....	1-1
1.1 Purpose .....	1-1
1.2 Scope .....	1-1
1.3 Relationship With Program or Project Phases.....	1-2
References .....	1-8
 2. CONCEPT DEVELOPMENT TOOLS .....	 2-1
2.1 Trade Studies .....	2-1
2.1.1 Description .....	2-1
2.1.2 Application.....	2-3
2.1.3 Procedures.....	2-3
2.1.4 Example .....	2-6
2.1.5 Advantages.....	2-8
2.1.6 Limitations .....	2-9
2.1.7 Bibliography.....	2-9
2.2 Cost-Versus-Benefit Studies.....	2-9
2.2.1 Description .....	2-9
2.2.2 Application.....	2-9
2.2.3 Procedures.....	2-10
2.2.4 Example .....	2-11
2.2.5 Advantages.....	2-13
2.2.6 Limitations .....	2-13
2.2.7 Bibliography.....	2-13
References .....	2-14
 3. SYSTEM SAFETY AND RELIABILITY TOOLS .....	 3-1
3.1 Risk Assessment Matrix .....	3-2
3.1.1 Description .....	3-2
3.1.2 Application.....	3-5
3.1.3 Procedures.....	3-6
3.1.4 Example .....	3-10
3.1.5 Advantages.....	3-12
3.1.6 Limitations .....	3-12
3.1.7 Bibliography.....	3-12

**TABLE OF CONTENTS (Continued)**

	Page
3.2 Preliminary Hazard Analysis.....	3-12
3.2.1 Description .....	3-12
3.2.2 Application.....	3-13
3.2.3 Procedures.....	3-13
3.2.4 Example .....	3-16
3.2.5 Advantages.....	3-17
3.2.6 Limitations .....	3-18
3.2.7 Bibliography.....	3-18
3.3 Energy Flow/Barrier Analysis .....	3-18
3.3.1 Description .....	3-18
3.3.2 Application.....	3-19
3.3.3 Procedures.....	3-19
3.3.4 Example .....	3-19
3.3.5 Advantages.....	3-21
3.3.6 Limitations .....	3-21
3.3.7 Bibliography.....	3-21
3.4 Failure Modes and Effects (and Criticality) Analysis .....	3-21
3.4.1 Description .....	3-21
3.4.2 Application.....	3-22
3.4.3 Procedures.....	3-22
3.4.4 Example .....	3-26
3.4.5 Advantages.....	3-28
3.4.6 Limitations .....	3-29
3.4.7 Bibliography.....	3-29
3.5 Reliability Block Diagram.....	3-30
3.5.1 Description .....	3-30
3.5.2 Application.....	3-32
3.5.3 Procedures.....	3-32
3.5.4 Example .....	3-33
3.5.5 Advantages.....	3-34
3.5.6 Limitations .....	3-34
3.5.7 Bibliography.....	3-35
3.6 Fault Tree Analysis .....	3-35
3.6.1 Description .....	3-35
3.6.2 Application.....	3-35
3.6.3 Procedures.....	3-36
3.6.3.1 Fault Tree Generation .....	3-37
3.6.3.2 Probability Determination.....	3-37
3.6.3.3 Identifying and Assessing Cut Sets.....	3-41
3.6.3.4 Identifying Path Sets .....	3-43

**TABLE OF CONTENTS (Continued)**

	Page	
3.6.4	Examples.....	3-44
	3.6.4.1 Fault Tree Construction and Probability Propagation.....	3-44
	3.6.4.2 Cut Sets .....	3-45
	3.6.4.3 Path Sets.....	3-46
3.6.5	Advantages.....	3-46
3.6.6	Limitations .....	3-47
3.6.7	Bibliography.....	3-47
3.7	Success Tree Analysis .....	3-48
	3.7.1 Description .....	3-48
	3.7.2 Application.....	3-48
	3.7.3 Procedures.....	3-49
	3.7.4 Example .....	3-50
	3.7.5 Advantages.....	3-51
	3.7.6 Limitations .....	3-51
	3.7.7 Bibliography.....	3-51
3.8	Event Tree Analysis.....	3-51
	3.8.1 Description .....	3-51
	3.8.2 Application.....	3-52
	3.8.3 Procedures.....	3-53
	3.8.4 Example .....	3-54
	3.8.5 Advantages.....	3-54
	3.8.6 Limitations .....	3-54
	3.8.7 Bibliography.....	3-56
3.9	Fault Tree, Reliability Block Diagram, and Event Tree Transformations .....	3-56
	3.9.1 Description .....	3-56
	3.9.2 Application.....	3-56
	3.9.3 Procedures.....	3-56
	3.9.3.1 Fault Tree to RBD Transformation.....	3-56
	3.9.3.2 RBD and Fault Tree-to-Event Tree Transformation.....	3-56
	3.9.3.3 RBD to Fault Tree Transformation.....	3-58
	3.9.3.4 Event Tree to RBD and Fault Tree Transformation .....	3-58
	3.9.4 Example .....	3-58
	3.9.5 Advantages.....	3-61
	3.9.6 Limitations .....	3-61
	3.9.7 Bibliography.....	3-61
3.10	Cause-Consequence Analysis.....	3-61
	3.10.1 Description .....	3-61
	3.10.2 Application.....	3-62
	3.10.3 Procedures.....	3-62
	3.10.4 Example .....	3-64
	3.10.5 Advantages.....	3-64
	3.10.6 Limitations .....	3-65
	3.10.7 Bibliography.....	3-66



**TABLE OF CONTENTS (Continued)**

	Page
3.11 Directed Graphic (Digraph) Matrix Analysis .....	3-66
3.11.1 Description .....	3-66
3.11.2 Application.....	3-66
3.11.3 Procedures.....	3-67
3.11.4 Example .....	3-69
3.11.5 Advantages.....	3-70
3.11.6 Limitations .....	3-72
3.11.7 Bibliography.....	3-72
3.12 Combinatorial Failure Probability Analysis Using Subjective Information.....	3-72
3.12.1 Description .....	3-72
3.12.2 Application.....	3-73
3.12.3 Procedures.....	3-73
3.12.4 Example .....	3-74
3.12.5 Advantages.....	3-74
3.12.6 Limitations .....	3-74
3.13 Failure Mode Information Propagation Modeling.....	3-76
3.13.1 Description .....	3-76
3.13.2 Application.....	3-76
3.13.3 Procedures.....	3-76
3.13.4 Example .....	3-77
3.13.5 Advantages.....	3-78
3.13.6 Limitations .....	3-78
3.14 Probabilistic Design Analysis.....	3-78
3.14.1 Description .....	3-78
3.14.2 Application.....	3-78
3.14.3 Procedures.....	3-80
3.14.4 Advantages.....	3-83
3.14.5 Limitations .....	3-83
3.15 Probabilistic Risk Assessment.....	3-84
3.15.1 Description .....	3-84
3.15.2 Application.....	3-84
3.15.3 Procedures.....	3-84
3.15.4 Advantages.....	3-85
3.15.5 Limitations .....	3-85
References .....	3-86

**TABLE OF CONTENTS (Continued)**

	Page
4. DESIGN-RELATED ANALYTICAL TOOLS.....	4-1
4.1 Sensitivity (Parametric) Analysis .....	4-1
4.1.1 Description .....	4-1
4.1.2 Application.....	4-1
4.1.3 Procedures.....	4-1
4.1.4 Example .....	4-3
4.1.5 Advantages.....	4-4
4.1.6 Limitations .....	4-4
4.2 Standard Dimensioning and Tolerancing .....	4-5
4.2.1 Description .....	4-5
4.2.2 Application.....	4-5
4.2.3 Procedures.....	4-5
4.2.4 Example .....	4-6
4.2.5 Advantages.....	4-7
4.2.6 Limitations .....	4-7
4.3 Tolerance Stackup Analysis .....	4-7
4.3.1 Description .....	4-7
4.3.2 Application.....	4-7
4.3.3 Procedures.....	4-7
4.3.4 Example .....	4-8
4.3.5 Advantages.....	4-9
4.3.6 Limitations .....	4-9
4.3.7 Bibliography.....	4-9
References .....	4-10
5. GRAPHICAL DATA INTERPRETATION TOOLS.....	5-1
5.1 Scatter Diagram .....	5-1
5.1.1 Description .....	5-1
5.1.2 Application.....	5-1
5.1.3 Procedures.....	5-3
5.1.4 Example .....	5-3
5.1.5 Advantages.....	5-3
5.1.6 Limitations .....	5-3
5.2 Control Chart .....	5-4
5.2.1 Description .....	5-4
5.2.2 Application.....	5-4
5.2.3 Procedures.....	5-5
5.2.4 Example .....	5-5
5.2.5 Advantages.....	5-6
5.2.6 Limitations .....	5-6

**TABLE OF CONTENTS (Continued)**

	Page
5.3 Bar Chart.....	5-6
5.3.1 Description .....	5-6
5.3.2 Application.....	5-6
5.3.3 Procedures.....	5-6
5.3.4 Example .....	5-7
5.3.5 Advantages.....	5-7
5.3.6 Limitations .....	5-7
5.4 Time-Line Chart .....	5-8
5.4.1 Description .....	5-8
5.4.2 Application.....	5-8
5.4.3 Procedures.....	5-8
5.4.4 Example .....	5-8
5.4.5 Advantages.....	5-8
5.4.6 Limitations .....	5-9
5.5 Stratification Chart.....	5-9
5.5.1 Description .....	5-9
5.5.2 Application.....	5-9
5.5.3 Procedures.....	5-10
5.5.4 Example .....	5-11
5.5.5 Advantages.....	5-11
5.5.6 Limitations .....	5-11
5.6 Pareto Chart .....	5-11
5.6.1 Description .....	5-11
5.6.2 Application.....	5-11
5.6.3 Procedures.....	5-11
5.6.4 Example .....	5-12
5.6.5 Advantages.....	5-13
5.6.6 Limitations .....	5-13
5.6.7 Bibliography.....	5-13
5.7 Histograms.....	5-13
5.7.1 Description .....	5-13
5.7.2 Application.....	5-13
5.7.3 Procedures.....	5-13
5.7.4 Example .....	5-14
5.7.5 Advantages.....	5-14
5.7.6 Limitations .....	5-14
References.....	5-15

**TABLE OF CONTENTS (Continued)**

	Page
6. STATISTICAL TOOLS AND METHODOLOGIES.....	6-1
6.1 “Student-t” Analysis .....	6-1
6.1.1 Description .....	6-1
6.1.2 Application.....	6-1
6.1.3 Procedures.....	6-3
6.1.4 Example .....	6-3
6.1.5 Advantages.....	6-3
6.1.6 Limitations .....	6-4
6.1.7 Bibliography.....	6-4
6.2 Analysis of Variance.....	6-4
6.2.1 Description .....	6-4
6.2.2 Application.....	6-4
6.2.3 Procedures.....	6-4
6.2.4 Example .....	6-6
6.2.5 Advantages.....	6-7
6.2.6 Limitations .....	6-7
6.3 Correlation Analysis .....	6-7
6.3.1 Description .....	6-7
6.3.2 Application.....	6-7
6.3.3 Procedures.....	6-7
6.3.4 Example .....	6-8
6.3.5 Advantages.....	6-8
6.3.6 Limitations .....	6-8
6.4 Factorial Analysis .....	6-8
6.4.1 Description .....	6-8
6.4.2 Application.....	6-8
6.4.3 Procedures.....	6-9
6.4.4 Example .....	6-10
6.4.5 Advantages.....	6-12
6.4.6 Limitations .....	6-12
6.5 Confidence/Reliability Determination and Analysis .....	6-12
6.5.1 Description .....	6-12
6.5.2 Application.....	6-12
6.5.3 Procedures.....	6-13
6.5.4 Example .....	6-14
6.5.5 Advantages.....	6-14
6.5.6 Limitations .....	6-14

**TABLE OF CONTENTS (Continued)**

	Page
6.6 Regression Analysis.....	6-14
6.6.1 Description .....	6-14
6.6.2 Application.....	6-15
6.6.3 Procedures.....	6-15
6.6.4 Example .....	6-16
6.6.5 Advantages.....	6-17
6.6.6 Limitations .....	6-17
6.7 Response Surface Methodology .....	6-17
6.7.1 Description .....	6-17
6.7.2 Application.....	6-17
6.7.3 Procedures.....	6-17
6.7.4 Example .....	6-18
6.7.5 Advantages.....	6-19
6.7.6 Limitations .....	6-19
References .....	6-20
7. TOTAL QUALITY MANAGEMENT (TQM) TOOLS .....	7-1
7.1 Benchmarking.....	7-5
7.1.1 Description .....	7-5
7.1.2 Application.....	7-5
7.1.3 Procedures.....	7-5
7.1.4 Example .....	7-6
7.1.5 Advantages.....	7-6
7.1.6 Limitations .....	7-6
7.2 Cause and Effect Diagrams (Also Known as Fishbone Diagrams or Ishakawa Diagrams) .....	7-7
7.2.1 Description .....	7-7
7.2.2 Application.....	7-7
7.2.3 Procedures.....	7-7
7.2.4 Examples.....	7-8
7.2.5 Advantages.....	7-8
7.2.6 Limitations .....	7-10
7.2.7 Bibliography.....	7-10
7.3 Concurrent Engineering.....	7-10
7.3.1 Description .....	7-10
7.3.2 Application.....	7-10
7.3.3 Procedures.....	7-10
7.3.4 Example .....	7-11
7.3.5 Advantages.....	7-12
7.3.6 Limitations .....	7-12

**TABLE OF CONTENTS (Continued)**

	Page
7.4 Cost of Quality.....	7-12
7.4.1 Description .....	7-12
7.4.2 Application.....	7-12
7.4.3 Procedures.....	7-12
7.4.4 Example .....	7-14
7.4.5 Advantages.....	7-14
7.4.6 Limitations .....	7-15
7.5 Design of Experiments .....	7-15
7.5.1 Description .....	7-15
7.5.2 Application.....	7-15
7.5.3 Procedures.....	7-15
7.5.4 Example .....	7-16
7.5.5 Advantages.....	7-18
7.5.6 Limitations .....	7-18
7.5.7 Bibliography.....	7-19
7.6 Evolutionary Operation .....	7-19
7.6.1 Description .....	7-19
7.6.2 Application.....	7-19
7.6.3 Procedures.....	7-19
7.6.4 Example .....	7-20
7.6.5 Advantages.....	7-23
7.6.6 Limitations .....	7-23
7.7 Brainstorming .....	7-23
7.7.1 Description .....	7-23
7.7.2 Application.....	7-23
7.7.3 Procedures.....	7-24
7.7.4 Example .....	7-24
7.7.5 Advantages.....	7-25
7.7.6 Limitations .....	7-25
7.8 Checklists.....	7-26
7.8.1 Description .....	7-26
7.8.2 Application.....	7-26
7.8.3 Procedures.....	7-26
7.8.4 Example .....	7-26
7.8.5 Advantages.....	7-26
7.8.6 Limitations .....	7-26

**TABLE OF CONTENTS (Continued)**

	Page
7.9 Delphi Technique.....	7-27
7.9.1 Description .....	7-27
7.9.2 Application.....	7-27
7.9.3 Procedures.....	7-27
7.9.4 Example .....	7-28
7.9.5 Advantages.....	7-29
7.9.6 Limitations .....	7-29
7.10 Nominal Group Technique .....	7-30
7.10.1 Description .....	7-30
7.10.2 Application.....	7-30
7.10.3 Procedures.....	7-30
7.10.4 Example .....	7-30
7.10.5 Advantages.....	7-32
7.10.6 Limitations .....	7-32
7.11 Force Field Analysis .....	7-32
7.11.1 Description .....	7-32
7.11.2 Application.....	7-32
7.11.3 Procedures.....	7-34
7.11.4 Example .....	7-34
7.11.5 Advantages.....	7-35
7.11.6 Limitations .....	7-35
7.12 Quality Function Deployment .....	7-35
7.12.1 Description .....	7-35
7.12.2 Application.....	7-36
7.12.3 Procedures.....	7-36
7.12.4 Example .....	7-37
7.12.5 Advantages.....	7-40
7.12.6 Limitations .....	7-40
7.12.7 Bibliography.....	7-40
7.13 Quality Loss Function.....	7-41
7.13.1 Description .....	7-41
7.13.2 Application.....	7-42
7.13.3 Procedures.....	7-42
7.13.4 Example .....	7-43
7.13.5 Advantages.....	7-44
7.13.6 Limitations .....	7-44

**TABLE OF CONTENTS (Continued)**

	Page
7.14 Statistical Process Control .....	7-44
7.14.1 Description .....	7-44
7.14.2 Application.....	7-44
7.14.3 Procedures.....	7-44
7.14.4 Example .....	7-46
7.14.5 Advantages.....	7-48
7.14.6 Limitations .....	7-49
7.14.7 Bibliography.....	7-49
7.15 Flowchart Analysis .....	7-49
7.15.1 Description .....	7-49
7.15.2 Application.....	7-52
7.15.3 Procedures.....	7-52
7.15.4 Example .....	7-52
7.15.5 Advantages.....	7-52
7.15.6 Limitations .....	7-52
7.16 Work Flow Analysis .....	7-53
7.16.1 Description .....	7-53
7.16.2 Application.....	7-54
7.16.3 Procedures.....	7-54
7.16.4 Example .....	7-54
7.16.5 Advantages.....	7-55
7.16.6 Limitations .....	7-55
References .....	7-56
8. TREND ANALYSIS TOOLS.....	8-1
8.1 Performance Trend Analysis .....	8-4
8.1.1 Description .....	8-4
8.1.2 Application.....	8-4
8.1.3 Procedures.....	8-5
8.1.4 Example .....	8-7
8.1.5 Advantages.....	8-8
8.1.6 Limitations .....	8-8
8.1.7 Bibliography.....	8-8
8.2 Problem Trend Analysis .....	8-8
8.2.1 Description .....	8-8
8.2.2 Application.....	8-9
8.2.3 Procedures.....	8-10
8.2.4 Example .....	8-11
8.2.5 Advantages.....	8-15
8.2.6 Limitations .....	8-15
8.2.7 Bibliography.....	8-15



**TABLE OF CONTENTS (Concluded)**

	Page
8.3 Programmatic Trend Analysis .....	8-15
8.3.1 Description .....	8-15
8.3.2 Application.....	8-16
8.3.3 Procedures.....	8-16
8.3.4 Example .....	8-18
8.3.5 Advantages.....	8-18
8.3.6 Limitations .....	8-18
8.3.7 Bibliography.....	8-18
8.4 Supportability Trend Analysis.....	8-19
8.4.1 Description .....	8-19
8.4.2 Application.....	8-20
8.4.3 Procedures.....	8-21
8.4.4 Example .....	8-22
8.4.5 Advantages.....	8-22
8.4.6 Limitations .....	8-22
8.4.7 Bibliography.....	8-23
8.5 Reliability Trend Analysis.....	8-24
8.5.1 Description .....	8-24
8.5.2 Application.....	8-24
8.5.3 Procedures.....	8-25
8.5.4 Example .....	8-25
8.5.5 Advantages.....	8-25
8.5.6 Limitations .....	8-26
8.5.7 Bibliography.....	8-26
References.....	8-27
Appendix A .....	A-1
Appendix B .....	B-1
Appendix C .....	C-1
Appendix D .....	D-1
Appendix E .....	E-1
Appendix F .....	F-1

## LIST OF ILLUSTRATIONS

Figure	Title	Page
2-1.	Example utility functions .....	2-7
2-2.	Example weighted factor trade study summary table .....	2-8
3-1.	Risk plane .....	3-5
3-2.	Iso-risk contour usage .....	3-6
3-3.	Risk plane to risk matrix transformation .....	3-7
3-4.	Helpful hints in creating a risk assessment matrix .....	3-8
3-5.	Typical risk assessment matrix .....	3-10
3-6.	Severity and probability interpretations .....	3-11
3-7.	PHA process flowchart .....	3-14
3-8.	Typical PHA .....	3-16
3-9.	Example of system breakdown and numerical coding .....	3-23
3-10.	FMECA process flowchart .....	3-24
3-11.	Typical FMECA worksheet .....	3-26
3-12.	Example of an FMECA .....	3-27
3-13.	Typical complex RBD .....	3-31
3-14.	Example RBD .....	3-33
3-15.	Fault tree construction process.....	3-39
3-16.	Log average method of probability estimation .....	3-39
3-17.	Relationship between reliability and failure probability propagation.....	3-40
3-18.	Failure probability propagation through OR and AND gates .....	3-40
3-19.	Exact solution of OR gate failure probability propagation .....	3-41
3-20.	Example fault tree .....	3-44
3-21.	Example of determining cut sets .....	3-45
3-22.	Example of determining path sets .....	3-46
3-23.	Success tree construction process .....	3-49

## LIST OF ILLUSTRATIONS

Figure	Title	Page
3-24.	Example success tree .....	3-50
3-25.	Event tree (generic case) .....	3-52
3-26.	Event tree (Bernoulli model) .....	3-53
3-27.	Example ETA .....	3-55
3-28.	Fault tree to RBD transformation. ....	3-57
3-29.	Deriving cut and path sets from an RBD .....	3-57
3-30.	RBD to event tree transformation .....	3-58
3-31.	RBD to fault tree transformation .....	3-59
3-32.	Event tree to fault tree transformation .....	3-59
3-33.	Equivalent logic RBD and fault tree .....	3-60
3-34.	Relationship between cause and consequence .....	3-62
3-35.	Cause-consequence analysis format .....	3-64
3-36.	Example cause-consequence analysis .....	3-65
3-37.	Comparison between digraph and fault tree logic gates .....	3-68
3-38.	Construction of digraph adjacency matrix .....	3-69
3-39.	Example digraph matrix analysis .....	3-71
3-40.	Example combinatorial failure probability analysis .....	3-75
3-41.	Example failure mode information propagation model .....	3-79
3-42.	Load and capability transfer functions .....	3-82
3-43.	Interference between load and capability density functions .....	3-83
4-1.	Example of dimensioning and tolerancing .....	4-6
4-2.	O-ring joint .....	4-8
4-3.	O-ring joint components .....	4-8
5-1.	Scatter diagram example.....	5-4
5-2.	Control chart example.....	5-5

## LIST OF ILLUSTRATIONS

Figure	Title	Page
5-3.	Bar chart example .....	5-7
5-4.	Time-line chart example .....	5-9
5-5.	Stratification (histogram) chart example .....	5-10
5-6.	Pareto chart example.....	5-12
5-7.	Histogram example .....	5-14
6-1.	Line generated with least squares method .....	6-16
7-1.	Comparative benchmarking .....	7-6
7-2.	Design rework cause and effect diagram .....	7-8
7-3.	Cause and effect diagram on receiving telephone messages .....	7-9
7-4.	Concurrent engineering example .....	7-11
7-5.	Standard cost of quality curve.....	7-13
7-6.	Factor/level effects graph.....	7-18
7-7.	EVOP example.....	7-20
7-8.	Sample of a partial igniter subsystem fault tree.....	7-28
7-9.	Fault tree sample with estimates assigned .....	7-29
7-10.	Force field analysis example.....	7-34
7-11.	House of quality .....	7-35
7-12.	QFD example on automobile industry .....	7-39
7-13.	Traditional view to meeting specification.....	7-41
7-14.	Quality loss function for NIB.....	7-42
7-15.	Quality loss function example.....	7-43
7-16.	Control chart showing mean deviation for each part .....	7-47
7-17.	Range chart showing mean range for each part .....	7-47
7-18.	Pareto chart showing mean deviation for each hole guide.....	7-48
7-19.	Control chart showing mean deviation for hole guide 1.....	7-48

## LIST OF ILLUSTRATIONS

Figure	Title	Page
7-20.	Example of top-down flowchart .....	7-49
7-21.	Example of detailed flowchart .....	7-50
7-22.	Common flowchart symbols .....	7-51
7-23.	Work flow diagram example .....	7-53
7-24.	WFA example .....	7-55
8-1.	Performance trend analysis example .....	8-7
8-2.	Problem trend analysis example .....	8-12
8-3.	Programmatic trend analysis example .....	8-19
8-4.	Supportability trend analysis example .....	8-23
8-5	Reliability trend analysis example .....	8-25

## LIST OF TABLES

Table	Title	Page
1-1.	System engineering “toolbox” function matrix .....	1-3
1-2.	System engineering “toolbox” project phase matrix .....	1-5
2-1.	Concept development tools and methodologies .....	2-2
2-2.	Typical weighted trade study summary table .....	2-5
2-3.	Example selection criteria for cost-versus-benefit analyses .....	2-10
3-1.	Symbolic logic techniques .....	3-2
3-2.	System safety and reliability tools and methodologies .....	3-3
3-3.	Examples of strategies to manage harmful energy flow .....	3-20
3-4.	Simple RBD construction .....	3-30
3-5.	FTA procedures .....	3-36
3-6.	Fault tree construction symbols .....	3-38
3-7.	Probability propagation expressions for logic gates .....	3-42
3-8.	Cause-consequence tree construction symbols .....	3-63
3-9.	Combinatorial failure probability analysis subjective scale .....	3-73
4-1.	Design-related analytical tools and methodologies .....	4-2
4-2.	Sensitivity analysis calculations .....	4-4
5-1.	Graphical data interpretation tools and methodologies .....	5-2
6-1.	Statistical tools and methodologies .....	6-2
6-2.	Factorial analysis factors and magnitudes .....	6-9
6-3.	Factorial analysis example .....	6-10
7-1.	TQM tools and methodologies .....	7-2
7-2.	Month’s cost of quality .....	7-14
7-3.	2 <sup>3</sup> factorial design data.....	7-16
7-4.	Trial, effects, and results .....	7-16

**LIST OF TABLES (Continued)**

Table	Title	Page
7-5.	Calculation of effects .....	7-17
7-6.	EVOP cycle No. 1 data .....	7-20
7-7.	EVOP cycle No. 2 data .....	7-21
7-8.	Comparison of EVOP cycle No. 1 and cycle No. 2 data .....	7-22
7-9.	Motor postflight checklist .....	7-27
7-10.	Replacement technology concerns .....	7-31
7-11.	Concerns with assigned weighting factors .....	7-33
7-12.	QFD matrix sample calculations .....	7-37
7-13.	Nominal hole size deviations and drill guide positions .....	7-46
8-1.	Trend analysis tools and methodologies .....	8-3

## ACRONYMS

AHP	Analytical hierarchy process
AHPA	Analytical hierarchy process approach
AIAA	American Institute of Aeronautics and Astronautics
ANOVA	Analysis of variance
B/C	Benefit-to-cost
CIL	Critical items list
CIM	Change in mean
CSF	Compliance safety factor
DAS	Data acquisition system
DOE	Design of experiments
DOF	Degree-of-freedom
DR	Discrepancy report
EF	External failure
ETA	Event tree analysis
EVOP	Evolutionary operation
FMEA	Failure modes and effects analysis
FMECA	Failure modes, effects, and criticality analysis
FTA	Fault tree analysis
IF	Internal failure
$L(y)$	Loss function (quality)
LCL	Lower control limits
LDL	Lower decision line
LIB	Larger is better



**ACRONYMS (Continued)**

LSL	Lower specification limit
MTBF	Mean time between failures
MTBR	Mean time between repairs
MTTR	Mean time to repair
NASA	National Aeronautics and Space Administration
NGT	Nominal group technique
NIB	Nominal is best
PDA	Probabilistic design analysis
PHA	Preliminary hazard analysis
PRA	Probabilistic risk assessment
PRACA	Problem reporting and corrective action
OSHA	Occupational Safety and Health Administration
QFD	Quality function deployment
RBD	Reliability block diagram
RSM	Response surface methodology
SE	Standard error
SESTC	System Effectiveness and Safety Technical Committee
SIB	Smaller is better
SME	Sum of mean error
SMQ	Safety and mission quality
SMR	Sum of mean replicate
SPC	Statistical process control
SRM	Solid rocket motor

### **ACRONYMS (Continued)**

SSE	Sum of squares error
SSR	Sum of squares replication
SST	Total sum of squares
STA	Success tree analysis
TQM	Total quality management
UCL	Upper control limit
UCLR	Upper control limit range
UDL	Upper decision line
USL	Upper specification limit
WFA	Work flow analysis



## REFERENCE PUBLICATION

### SYSTEM ENGINEERING “TOOLBOX” FOR DESIGN-ORIENTED ENGINEERS

#### 1. INTRODUCTION

##### 1.1 Purpose

Many references are available on systems engineering from the project management perspective. Too often, these references are of only limited utility from the designer's standpoint. A practicing, design-oriented systems engineer has difficulty finding any ready reference as to what tools and methodologies are available.

The purpose of this system engineering toolbox is to provide tools and methodologies available to the design-oriented systems engineer. A tool, as used herein, is defined as a set of procedures to accomplish a specific function. A methodology is defined as a collection of tools, rules, and postulates to accomplish a purpose. A thorough literature search was performed to identify the prevalent tools and methodologies. For each concept addressed in the toolbox, the following information is provided: (1) description, (2) application, (3) procedures, (4) example, if practical, (5) advantages, (6) limitations, and (7) bibliography and/or references.

This toolbox is intended solely as guidance for potential tools and methodologies, rather than direction or instruction for specific technique selection or utilization. It is left to the user to determine which technique(s), at which level of detail are applicable, and what might be the expected “value added” for their purposes. Caution should be exercised in the use of these tools and methodologies. Use of the techniques for the sake of “using techniques” is rarely resource-effective. In addition, while techniques have been categorized for recommended areas of use, this is not intended to be restrictive. Readers are encouraged to question, comment (app. A) and, in general, use this reference as one source among many. The reader is also cautioned to validate results from a given tool to ensure accuracy and applicability to the problem at hand.

##### 1.2 Scope

The tools and methodologies available to the design-oriented systems engineer can be categorized in various ways depending upon the application. Concept development tools, section 2, are useful when selecting the preferred option of several alternatives. Among these alternatives are such things as cost, complexity, weight, safety, manufacturability, or perhaps determining the ratio of expected future benefits to the expected future costs.

System safety and reliability tools, section 3, address the following areas of concern: (1) identify and assess hazards, (2) identify failure modes and show their consequences or effects, and (3) symbolic logic modeling tools used to understand the failure mechanisms of the system. These tools are also used to determine the probability of failure occurring or the reliability that a component will operate successfully, either in comparative or absolute terms, as applicable.

Design-related analytical tools, section 4, are applied to show (1) which parameters affect a system the most or least, (2) a method for specifying dimensions and tolerances, and (3) the determination of the possibility or probability of having form, fit, or function problems with a design, or to determine a tolerance or dimension necessary to avoid these problems.

When there is a desire to monitor performance, identify relationships, or reveal the most important variables in a set of data, graphical data interpretation tools are typically applied. These tools are discussed in section 5. Statistical tools and methodologies, section 6, compare sample statistics and population statistics. Variations are identified and mathematical relationships are determined. Many excellent texts are available on statistical methods, as are software packages. For this reason, this document touches only lightly on this area.

Total quality management (TQM) tools, section 7, are applied to continuously improve performance at all levels of operation, in all areas of an organization, using all available human and capital resources. Finally, quantitative tools that are used to identify potentially hazardous conditions based on past empirical data are trend analysis tools, section 8. The ultimate objective for these tools is to assess the current status, and to forecast future events.

To assist in further defining optimal areas in which each technique may be useful, table 1-1 provides a functional matrix which categorizes the functionality of each tool or methodology into (1) data analysis, (2) problem identification, (3) decision making, (4) modeling, (5) prevention, (6) creative, and (7) graphical. These functionality categories are found in reference 1.1.

Extensive research was performed in order to identify all prevalent tools and methodologies available to the design-oriented systems engineer. Nevertheless, important tools or methodologies may have been overlooked. If a tool or methodology should be considered for this toolbox, appendix A is provided for the reader to complete and return to the individual indicated on the form.

To further illustrate how selected tools and methodologies in this toolbox are applied, and misapplied, appendix B provides a case study illustrating the trials and tribulations of an engineer applying his recently acquired knowledge of the techniques to a given work assignment.

Appendix C provides a glossary of terms applicable to the tools and methodologies in this toolbox.

### **1.3 Relationship With Program or Project Phases**

Each tool or methodology may be performed in a minimum of one of the following phases, as described in reference 1.2, of a project design cycle.

- (1) Phase A (conceptual trade studies)—a quantitative and/or qualitative comparison of candidate concepts against key evaluation criteria to determine the best alternative.
- (2) Phase B (concept definition)—the establishment of system design requirements as well as conceptually designing a mission, conducting feasibility studies and design trade-off studies.
- (3) Phase C (design and development)—the initiation of product development and the establishment of system specifications.
- (4) Phase D (fabrication, integration, test, and evaluation)—system verification.
- (5) Phase E (operations)—the deployment of the product and performance validation.

Table 1-2 provides a project phase matrix for all of the tools and methodologies identified in this toolbox. An entry of (1) for the phase means the technique is primarily performed in that phase and an entry of (2) means the technique is secondarily performed in that phase. Though the entries in this matrix are a result of research by the authors, other phases should be considered by the user for a particular tool or methodology.

Table 1-1. System engineering “toolbox” function matrix—Continued

Section	Tool or Methodology	Data Analysis	Problem Identification	Decision Making	Modeling	Prevention	Creative	Graphical
	Concept development tools							
2.1	Trade studies	√		√				
2.2	Cost-versus-benefit studies	√		√				
	System safety and reliability tools							
3.1	Risk assessment matrix		√	√				
3.2	Preliminary hazard analysis,	√	√	√		√		
3.3	Energy flow/barrier analysis	√	√	√		√		
3.4	Failure modes and effects analysis	√	√	√		√		
3.5	Reliability block diagram			√	√	√		√
3.6	Fault tree analysis	√	√	√	√	√		√
3.7	Success tree analysis	√		√	√	√		√
3.8	Event tree analysis	√		√	√	√		√
3.9	Fault tree/reliability block diagram/event tree transformations	√	√	√		√		√
3.10	Cause-consequence analysis	√	√	√	√	√		√
3.11	Directed graph (digraph) matrix analysis	√		√	√	√		√
3.12	Combinatorial failure probability analysis using subjective information	√	√	√				
3.13	Failure mode information propagation modeling		√	√	√	√		
3.14	Probabilistic design analysis	√		√				
3.15	Probabilistic risk assessment	√	√	√	√	√		
	Design-related analytical tools							
4.1	Sensitivity (parametric) analysis	√		√				
4.2	Standard dimensioning and tolerancing							√
4.3	Tolerance stackup analysis	√	√	√				
	Graphical data interpretation tools							
5.1	Scatter diagram							√
5.2	Control chart	√	√			√		√
5.3	Bar chart							√
5.4	Time-line chart							√
5.5	Stratification chart							√
5.6	Pareto chart	√	√			√		√
5.7	Histograms							√

Note: Functionality categories found in reference 1.1.

Table 1-1. System engineering “toolbox” function matrix—Continued.

Section	Tool or Methodology	Data Analysis	Problem Identification	Decision Making	Modeling	Prevention	Creative	Graphical
	Statistical tools and methodologies							
6.1	“Student-t” analysis	√	√	√				
6.2	Analysis of variance	√	√	√				
6.3	Correlation analysis	√	√	√				
6.4	Factorial arrays	√	√	√				
6.5	Confidence/reliability determination and analysis	√	√	√				
6.6	Regression analysis	√	√	√				√
6.7	Response surface methodology	√	√	√				√
	TQM tools							
7.1	Benchmarking			√	√			
7.2	Cause and effect diagrams		√					√
7.3	Concurrent engineering		√	√			√	
7.4	Cost of quality		√	√				
7.5	Design of experiments	√				√		
7.6	Evolutionary operation	√				√	√	
7.7	Brainstorming		√			√	√	
7.8	Checklists	√	√			√		
7.9	Delphi technique		√	√				
7.10	Nominal group technique		√	√			√	
7.11	Force field analysis	√	√	√				
7.12	Quality function deployment		√		√			√
7.13	Quality loss function	√	√					
7.14	Statistical process control	√	√	√				√
7.15	Flowchart analysis				√			√
7.16	Work flow analysis				√			√
	Trend analysis tools							
8.1	Performance trend analysis	√	√			√		√
8.2	Problem trend analysis	√	√			√		√
8.3	Programmatic trend analysis	√	√			√		√
8.4	Supportability trend analysis	√	√			√		√
8.5	Reliability trend analysis	√	√			√		√

Note: Functionality categories found in reference 1.1.

Table 1-2. System engineering “toolbox” project phase matrix—Continued

	Code: 1—Primary 2—Secondary	Phase A	Phase B	Phase C	Phase D	Phase E
Section	Tool or Methodology	Conceptual Trade Studies	Concept Definition	Design and Development	Fabrication, Integration, Test, and Evaluation	Operations
	Concept development tools					
2.1	Trade studies	1	2			
2.2	Cost versus benefit studies	1	2	2		
	System safety and reliability tools					
3.1	Risk assessment matrix	2		1		
3.2	Preliminary hazard analysis,		2	1		
3.3	Energy flow/barrier analysis		2	1		2
3.4	Failure modes and effects analysis			1		
3.5	Reliability block diagram			1		
3.6	Fault tree analysis			1	2	
3.7	Success tree analysis			1	2	
3.8	Event tree analysis			1	2	1
3.9	Fault tree/reliability block diagram/event tree transformations		2	1		
3.10	Cause-consequence analysis			1	2	1
3.11	Directed graph (digraph) matrix analysis		1			
3.12	Combinatorial failure probability analysis using subjective information			1		
3.13	Failure mode information propagation modeling			1	2	
3.14	Probabilistic design analysis			1		
3.15	Probabilistic risk assessment			1		

Note: Phases discussed in reference 1.2.



Table 1-2. System engineering “toolbox” project phase matrix—Continued

	Code: 1—Primary 2—Secondary	Phase A	Phase B	Phase C	Phase D	Phase E
Section	Tool or Methodology	Conceptual Trade Studies	Concept Definition	Design and Development	Fabrication, Integration, Test, and Evaluation	Operations
	Design-related analytical tools					
4.1	Sensitivity (parameteric) analysis			1	1	
4.2	Standard dimensioning and tolerancing			1	2	
4.3	Tolerance stackup analysis			1	1	
	Graphical data interpretation tools					
5.1	Scatter diagram					1
5.2	Control chart					1
5.3	Bar chart					1
5.4	Time-line chart					1
5.5	Stratification chart					1
5.6	Pareto chart					1
5.7	Histograms					1
	Statistical tools and methodologies					
6.1	“Student-t” analysis			2	1	2
6.2	Analysis of variance			2	1	2
6.3	Correlation analysis			2	1	2
6.4	Factorial arrays			1	2	2
6.5	Confidence/reliability determination and analysis			1	1	1
6.6	Regression analysis				1	2
6.7	Response surface methodology				1	1

Note: Phases discussed in reference 1.2.

Table 1-2. System engineering “toolbox” project phase matrix—Continued.

	Code: 1—Primary 2—Secondary	Phase A	Phase B	Phase C	Phase D	Phase E
Section	Tool or Methodology	Conceptual Trade Studies	Concept Definition	Design and Development	Fabrication, Integration, Test, and Evaluation	Operations
	TQM tools					
7.1	Benchmarking	2	2			1
7.2	Cause and effect diagrams	2	2			1
7.3	Concurrent engineering		2	1		
7.4	Cost of quality					1
7.5	Design of experiment			1	2	
7.6	Evolutionary operation				2	1
7.7	Brainstorming	1		2		
7.8	Checklists	2	2			1
7.9	Delphi technique	1	1			2
7.10	Nominal group technique	1	1			2
7.11	Force field analysis				1	1
7.12	Quality function deployment	2	2	1		
7.13	Quality loss function				2	1
7.14	Statistical process control					1
7.15	Flowchart analysis		1			2
7.16	Work flow analysis					1
	Trend analysis tools					
8.1	Performance trend analysis				2	1
8.2	Problem trend analysis				2	1
8.3	Programmatic trend analysis					1
8.4	Supportability trend analysis					1
8.5	Reliability trend analysis				2	1

Note: Phases discussed in reference 1.2.

## REFERENCES

- 1.1 Brocka, B., and Brocka, M.S.: "Quality Management, Implementing the Best Ideas of the Masters." Business One Irwin, Homewood, Illinois 60430.
- 1.2 "System Engineering Process (Short Course Lecture Notebook)." Center for Systems Management (CSM), Santa Rosa, California, September 1991.

## 2. CONCEPT DEVELOPMENT TOOLS

Trade studies and cost-versus-benefit studies are presented in this section. These tools are used to select the preferred option of several alternatives. Trade studies, section 2.1, are quantitative and/or qualitative comparison techniques to choose an alternative when considering such items as cost, complexity, weight, safety, manufacturability, etc. Cost-versus-benefit studies, section 2.2, provide a method to assess alternatives by determining the ratio of expected future benefits to expected future costs.

A summary of the advantages and limitations of each tool or methodology discussed in this section is presented in table 2-1.

### 2.1 TRADE STUDIES

#### 2.1.1 Description

In general, trade (or trade-off) studies provide a mechanism for systematic depiction of both system requirements and system design options for achieving those requirements. Once tabulated, a comparison of relevant data (cost, complexity, weight, safety, manufacturability, etc.) is then performed to rank those candidate design options in order of desirability.

These studies are categorized as either a weighted factor trade study or an analytical hierarchy trade study, with the latter being a special version of the former. These techniques are described in reference 2.1. A trade tree can be generated with either of the above two options. A trade tree is simply a pictorial representation of how high-level alternatives (or issues) in the decision process are logically resolved into decreasingly lower level alternatives (or issues). A trade tree may be presented without results or simply as a representation of options.

A weighted factor trade study is usually performed when each of the options under consideration is very well defined and there is good definition of the program requirements as well. All factors (program requirements) that are determined to be important, are delineated with an associated weighting factor. The options are then assessed with respect to each of the factors and an equation is developed that weighs this assessment. The decision is then based upon the numerical results of the analysis.

The analytical hierarchy process (AHP) is a variation of the weighted factors analysis and is the most complex of the trade studies presented here. This approach allows for delineation of the facts and rationale that go into the subjective assessment of each of the options. Further, pseudoquantitative equations may be developed (as in probabilistic assessment equations for failure causes in fault tree analyses) to increase confidence in analysis results. The AHP provides a multicriteria analysis methodology that employs a pairwise comparison process to compare options to factors in a relative manner. This is used when subjective verbal expressions (equal, moderate, strong, very strong, etc.) are easier to develop than numerical (3 versus 3.2, etc.) assessments. Pseudoquantitative numbers are then ascribed to the words and a score developed for each of the options.

A key to any trade study is the initial selection and prioritization of specific desirable attributes. This is often very difficult and the prioritization delineation may change during the early phases of the program. It is very important, and often overlooked, that when the prioritization changes, a cursory look at the significant, completed trades should be performed to determine any impacts to their conclusions.

Table 2-1. Concept development tools and methodologies.

Tool or Methodology	Section	Advantages	Limitations
Trade studies	2.1	<ul style="list-style-type: none"> <li>(1) Different kinds and/or levels of study allow flexibility in the depth of the review, i.e., resources expended can be commensurate with the benefits of the task.</li> <li>(2) Adaptive to prioritization based upon programmatic (cost, schedule) considerations as well as technical (weight, reliability, etc.) ones.</li> <li>(3) Identification of disadvantages of specific design option may lead to the definition of effective countermeasures if combined with other techniques.</li> </ul>	<ul style="list-style-type: none"> <li>(1) Very dependent upon the expertise of the analyst and the amount of available accurate quantitative data.</li> <li>(2) Improper generation of selection criteria, weight factors, and utility functions can prejudice the assessment and lead to incorrect results.</li> <li>(3) The number of alternatives which can be considered is limited by the expenditure of resources required to perform the analysis.</li> <li>(4) Options evaluated are not determined as a result of the study but must be decided upon prior to the assessment by the operator.</li> <li>(5) Weighting factors and advantages/disadvantages are very subjective (although objective data may be added which significantly complicates and enlarges the study) and this subjectivism is very near to the study conclusions.</li> </ul>
Cost-versus-benefit studies	2.2	<ul style="list-style-type: none"> <li>(1) By performing a cost-versus-benefit analysis, the analyst can assess the cost effectiveness of several alternatives over the entire life cycle of the proposed system under consideration.</li> <li>(2) Provides documentation of the parameters evaluated and the prioritized options considered.</li> </ul>	<ul style="list-style-type: none"> <li>(1) The analysis is flawed if system requirements are incomplete or inadequate. If the system operating environment is not understood or accurately characterized, the total costs can be underestimated. If the system requirements are too general or vague, the effectiveness of benefits can not be addressed in specific, measurable terms.</li> <li>(2) The analysis is only as good as the list of alternatives considered. An incomplete list of alternatives will lead to an incomplete analysis.</li> <li>(3) The analysis is flawed if incomplete or inaccurate cost estimates are used.</li> <li>(4) The analyst must be able to quantify the value of benefits, which are often intangible or insubstantial and difficult to characterize in terms of monetary value.</li> </ul>

### 2.1.2 Application

These studies should typically be performed in phase A of NASA projects. However, trade studies can also be performed in phase B, or whenever a method is needed to select alternatives, such as selecting test methods, evaluating design change proposals, or performing make-or-buy decisions. A trade study analysis allows a systematic approach to evaluation of design options with respect to programmatic considerations or other, nonreliability related considerations (weight, maintainability, manufacturability). These studies may also be used to help the designer delineate which system requirements are most important (used in conjunction with the Pareto chart analysis, sec. 5.6).

### 2.1.3 Procedures

The procedures for performing a weighted trade study are presented below. By performing step 6, an AHP weighted trade study will be performed. These procedures are described in detail and were adapted from reference 2.1.

- (1) Define the mission objectives and requirements for the system under consideration. These objectives and requirements should be clear, accurate, and specific. These requirements will provide the scope of the assessment and the basis for the selection criteria. Prioritize the objectives/requirements if possible; this will aid in the weight factors for the selection criteria.
- (2) Identify credible alternative candidates for the system under consideration. These alternatives can be imposed or obtained in brainstorming sessions (sec. 7.7). The list of alternatives selected during brainstorming sessions may be reduced by eliminating alternatives which do not appear capable of meeting requirements. The list may be reduced further by eliminating alternatives with low probability of successful implementation or those which are expected to exceed cost constraints. The remaining alternatives should be described in sufficient detail that the relative merits between them can be ascertained.
- (3) Develop a trade tree (optional). A trade tree is developed to graphically illustrate the alternatives and how high-level alternatives in the decision process are logically resolved into decreasingly lower level alternatives. For large trade studies with many alternatives and criteria attributes, create a trade tree to group alternatives with unique criteria attributes. A large trade study may be resolved into several smaller trade studies with fewer required total comparison evaluations. This will lead to fewer resources to conduct the assessment without degradation of the results.
- (4) Develop and specify the selection criteria to be used in the analysis. The selection criteria are benchmarks to assess the effectiveness and applicability characteristics of the alternatives to be considered. Ideally, the selection criteria should have the following characteristics:
  - a. Be expressed in general terms that mean the same thing to every evaluator.
  - b. Be practical to measure or predict within acceptable uncertainty and cost limits.
  - c. Provide a distinction between alternatives without prejudice.
  - d. Correlate directly to the established requirements and high priority issues. (A numbering system, showing the specific correlation, is often useful here.)
  - e. Be separate and independent from each of the other selection criterion in all aspects of the assessment.

- (5) Establish weights for the selection criteria. These weights should reflect the importance of each criterion relative to its importance to the overall selection decision. The weights should be given numerical values to accommodate objective comparisons between unrelated criteria. The numerical values of the weight factors should sum to 100. The weights should be predetermined by the person (or group) with the ultimate decision authority, but not necessarily shared with the analysts to ensure that alternatives are assessed against each criterion objectively. Each criterion may be resolved into several levels of components to establish its weight. The degree to which the individual criterion is resolved into components is dependent on how effective the criterion components can be evaluated, and represents the resolution limit of the assessment.

Consult with the end user of the system (the internal or external customer) to verify that the selection criteria and weights are compatible with his needs.

- (6) Perform an analytical hierarchy process as described in reference 2.2 to establish weights for the selection criteria (optional). This technique is beneficial for very complex trade studies when operational data are not available and a subjective analysis is to be performed. The following steps define this process:
- a. Establish a scale of the relative level of significance to the system objectives between two given criteria attributes. Establish three to five definitions to subjectively define this scale of relative level of significance. Generate clarifications for each definition so that qualified managers and engineers can subjectively use the definitions. If five definitions are used, assign the numerical values 1, 3, 5, 7, and 9 to these definitions in order of increasing diversity between the given two attributes. Reserve the numerical values of 2, 4, 6, and 8 as values to be assigned when interpolating between two of the definitions. If attribute  $n$  has a numerical value of relative level of significance of " $j$ " relative to attribute  $m$ , then attribute  $m$  has a numerical value of relative level of significance of " $1/j$ " relative to attribute  $n$ .
  - b. Survey a group of qualified managers and engineers (or customers) to establish a consensus on the relative relationships between each attribute and the rest of the attributes.
  - c. Create a normalized matrix (all the attributes versus all the attributes) with these relationships. Note that all elements of the diagonal of this matrix equal 1.
  - d. Determine the relative weights for each criterion component by performing an eigenvector analysis.
  - e. Determine the weight for all attributes by calculating the product of each individual attribute weighing factor and its weights of associated category headings.
- (7) Generate utility functions (optional). This technique is used to establish a consistent scale for dissimilar criteria. A relationship is established between a measure of effectiveness for each selection criterion and a common scale (for example, 0 to 10). The relationship may be a continuous function (not necessarily a straight line) or discrete values. For attributes other than technical, such as cost, schedule, risk, etc., a subjective verbal scale may be used (i.e., high, medium, low).
- (8) Assess each alternative relative to the selection criteria. First estimate the performance of every alternative for a given criterion in terms of the measure of effectiveness used in generating the utility functions. For the ideal situation, the analyst may use test data, vendor provided data, similarity comparison, modeling, engineering experience, parametric

analysis, or other cost-effective and reliable methods to generate the performance estimates. In reality, this is often very difficult to perform objectively. It is worthwhile, however, even when somewhat subjective (i.e., heavy use of engineering experience). If quantification of qualitative ranking is required, use caution in drawing conclusions. Assume that a difference in the conclusion of less than one-half the quantified number of a one-step difference is an equivalent answer. This corresponds to a confidence band for the evaluation.

Next, determine the score for each alternative relative to a given criterion by correlating the estimate of performance for all the criteria to the mutual scale using the utility functions generated in step 7. Next, multiply the scores for all alternatives by the weight factor for the criterion (determined in steps 5 or 6) to determine the weighted score for all alternatives for that criterion. Repeat this procedure for all criteria attributes.

- (9) Tabulate the results. Generate a matrix of criteria versus alternatives to summarize the results from the preceding steps. A typical table is illustrated in table 2-2 and was generalized from an example presented in reference 2.1.

Table 2-2. Typical weighted trade study summary table.<sup>2.1</sup>

Criteria		Alternates, $x_i$ ( $x_1$ through $x_n$ )							
Criterion, $y_j$	Weights $\Sigma w_j = 100$	Alternate $x_1$		Alternate $x_2$		Alternate $x_3$ Through Alternate $x_{n-1}$		Alternate $x_n$	
		Score (0-10)	Weighted Score	Score (0-10)	Weighted Score	Score (0-10)	Weighted Score	Score (0-10)	Weighted Score
$y_1$	$w_1$	$s_{11}$	$w_1 s_{11}$	$s_{21}$	$w_1 s_{21}$			$s_{n1}$	$w_1 s_{n1}$
$y_2$	$w_2$	$s_{12}$	$w_2 s_{12}$	$s_{22}$	$w_2 s_{22}$			$s_{n2}$	$w_2 s_{n2}$
$y_3$	$w_3$	$s_{13}$	$w_3 s_{13}$	$s_{23}$	$w_3 s_{23}$			$s_{n3}$	$w_3 s_{n3}$
$y_4$ to $y_{m-1}$									
$y_m$	$w_m$	$s_{1m}$	$w_m s_{1m}$	$s_{2m}$	$w_m s_{2m}$			$s_{nm}$	$w_m s_{nm}$
Total			$\Sigma(w_j s_{ij})_j$		$\Sigma(w_j s_{ij})_j$				$\Sigma(w_j s_{ij})_j$

- (10) Perform a sensitivity analysis to evaluate the merit of the results relative to making an alternate selection. Examine the results of the weighted trade study to see if any total weighted scores of any alternatives are closer in numerical value than is warranted in making a decision due to the confidence levels of the performance estimates that had been used to establish the scores. If this is the case, then gather more data to increase the confidence level of the performance estimates, repeat the assessment, and regenerate the summary table for the weighted trade study. If, after the analysis is repeated, the alternative numerical total score is too close to make a decision, reconsider the selection criterion and weighting factors.
- (11) Select the superior alternative. Select the alternative with the highest value of total weighted scores.



### 2.1.4 Example

#### Problem:

Four alternatives for a new automobile design are being considered. The selection decision will be based on comparing the four alternatives to the following criteria attributes and their associated weight factors:

<u>Item</u>	<u>Criteria Attribute</u>	<u>Weight Factor</u>
1	Average fuel economy	20
2	Acceleration (0 to 60 mph)	15
3	Braking (70 to 0 mph)	15
4	Road handling	15
5	Implement new technology risk	10
6	Cost	<u>25</u>
	Total	100

Utility functions have been generated for each criteria attribute and are presented in figure 2-1.

The estimates for each alternative relative to each criteria attribute are listed below:

<u>Item</u>	<u>Criteria attribute</u>	<u>Measure of Effectiveness</u>	Alt. <u>A</u>	Alt. <u>B</u>	Alt. <u>C</u>	Alt. <u>D</u>
1	Average fuel economy	miles per gallon	16	19	23	18
2	Acceleration (0 to 60 mph)	seconds	7	9	10	12
3	Braking (70 to 0 mph)	feet	180	177	190	197
4	Road handling (300 ft dia. skidpad)	g	0.86	0.88	0.83	0.78
5	Implementing new technology risks	--	Low	Avg.	High	Very low
6	Cost	Dollars, × 1,000	21	20	24	22

From the information given above, formulate a weighted factor trade study summary table, and select the superior alternative.

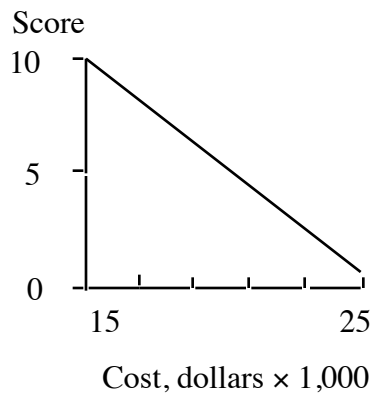
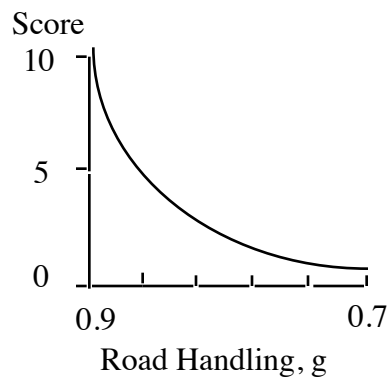
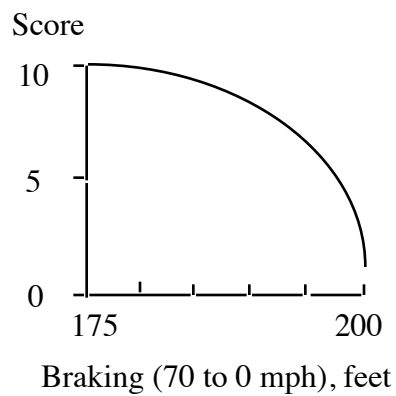
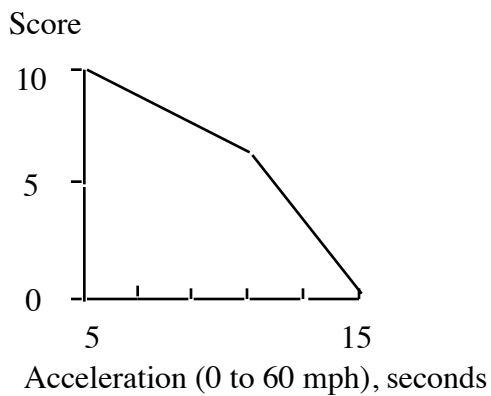
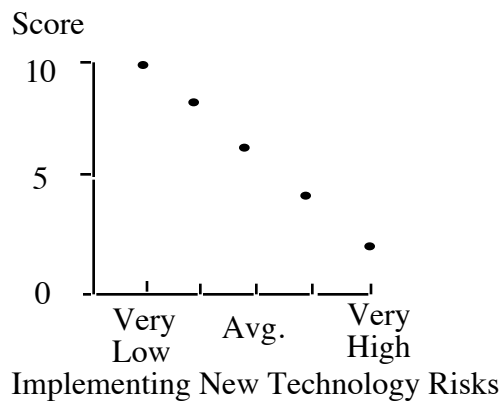
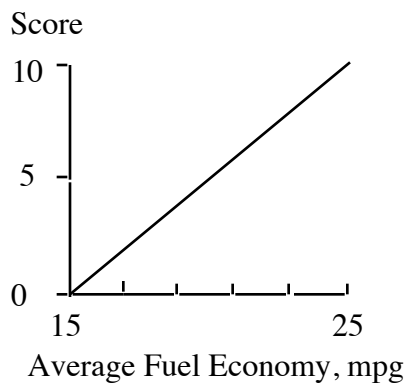

Figure 2-1. Example utility functions.

Solution:

Presented in figure 2-2 is the completed weighted factor trade study summary. Scores were determined from effectiveness measures for all alternatives relative to all criteria attributes and the utility functions. Based on the results of the trade study, alternative B is the preferred option.

Criteria		Alternates, $x_i$							
Attribute Item	Weights $\Sigma w_j = 100$	Alternate A		Alternate B		Alternate C		Alternate D	
		Score (0-10)	Weighted Score	Score (0-10)	Weighted Score	Score (0-10)	Weighted Score	Score (0-10)	Weighted Score
1	20	1	20	4	80	8	160	3	60
2	15	9	135	8	120	7.5	112.5	5	75
3	15	9.8	147	9.9	148.5	8.5	127.5	5	75
4	15	4.5	67.5	7	105	2.5	37.5	1.5	22.5
5	10	8	80	6	60	4	40	10	100
6	25	4	100	5	125	1	25	3	75
Total			549.5		638.5		502.5		407.5

Figure 2-2. Example weighted factor trade study summary table.

### 2.1.5 Advantages

The following advantages can be realized from performing trade studies:

- (1) Different kinds and/or levels of study allow flexibility in the depth of the review, i.e., resources expended can be commensurate with the benefits of the task.
- (2) This technique is adaptive to prioritization based upon programmatic considerations (cost, schedule) as well as technical ones (weight, reliability, etc.).
- (3) Identification of disadvantages of a specific design option may lead to the definition of effective countermeasures if combined with other techniques.
- (4) The method provides a clearly documented analysis in which the (a) prioritized objectives and requirements, (b) considered alternatives, and (c) selection methodology are recorded.

### 2.1.6 Limitations

The following limitations are associated with performing trade studies:

- (1) These techniques are very dependent upon the expertise of the analyst and the amount of available accurate quantitative data.<sup>2.1</sup>
- (2) Improper generation of selection criteria, weight factors, and utility functions can prejudice the assessment and lead to incorrect results.<sup>2.1</sup>
- (3) The number of alternatives which can be considered is limited by the expenditure of resources to perform the analysis.<sup>2.1</sup>
- (4) Options evaluated are not determined as a result of the study but must be decided upon prior to the assessment by the person (or group) with decision authority.
- (5) Weighting factors and advantages/disadvantages are very subjective (although objective data may be added in the analytical hierarchy process approach (AHPA), this significantly complicates and enlarges the study) and this subjectivism significantly influences the study conclusions.

### 2.1.7 Bibliography

Blanchard, B.S., and Fabreycky, W.J.: "System Engineering and Analysis." Second edition, Englewood Cliffs, Prentice Hall, New Jersey, pp. 67–72, 1990.

Cross, N.: "Engineering Design Methods." John Wiley & Sons, pp. 101–121, 1989.

Saaty, T. L.: "Analytical Hierarchy Process." McGraw-Hill, 1980.

## 2.2 COST-VERSUS-BENEFIT STUDIES

### 2.2.1 Description

Cost-versus-benefit studies are also known as benefit-cost analyses,<sup>2.3,2.4</sup> benefit-cost ratio analyses,<sup>2.5</sup> and cost-benefit analyses.<sup>2.6</sup> Cost-versus-benefit studies, as described in reference 2.5, provide a method to assess alternatives by determining the ratio of expected future benefits to expected future costs. Both the expected future benefits and costs are expressed in terms of present value. The alternatives are ranked in decreasing order with the preferred option being the alternative with the highest benefit-to-cost ( $B/C$ ) ratio, while falling within overall cost restraints.

### 2.2.2 Application

Benefit-cost analyses apply to the selection of projects<sup>2.3,2.4</sup> or machines or systems<sup>2.5,2.6</sup> based on their relative  $B/C$  ratios. Cost-versus-benefit studies, as discussed in this section, will apply to the selection of system or system element alternatives based on their relative  $B/C$  ratios. These studies should typically be performed in phase A, however, they could also be performed in phases B or C. These studies can be used when two or more alternatives are being considered with fixed cost constraints, fixed desired results or benefits, or when both costs and desired results vary.

### 2.2.3 Procedures

The following procedures to perform cost-versus-benefit studies were adapted from references 2.3, 2.5, and 2.6.

- (1) Define the requirements for the system or system element under consideration. These requirements should be measurable and verifiable. Translate general and vague requirements into specific, quantitative requirements in which system effectiveness can be measured and assessed.<sup>2,6</sup> Prioritize these requirements, if possible.
- (2) Define a list of credible, mutually exclusive alternatives; that is, if one alternative is selected, the others are not to be implemented.<sup>2,3</sup> Each alternative should be characterized to a level of completeness such that all substantial costs and benefits can be identified.<sup>2,6</sup> Note that the alternatives require an implicit determination of technical and schedule viability.
- (3) Develop and specify the selection criteria to be used in the analysis. The example selection criteria presented in table 2-3 were adapted from reference 2.5.

Table 2-3. Example selection criteria for cost-versus-benefit analyses.

Condition or Circumstance	Selection Criteria
Budget <i>C</i> is fixed	Maximum <i>B/C</i> ratio.
Desired result <i>B</i> is fixed.	Maximum <i>B/C</i> ratio.
Two alternatives are being considered with neither budget <i>C</i> or desired result <i>B</i> fixed.	Calculate the $\Delta B$ -to- $\Delta C$ ratio between the alternatives. Choose the lower cost alternative, unless the $\Delta B$ -to- $\Delta C$ ratio is $\geq 1$ . Then choose the higher cost alternative.
More than two alternatives are being considered with neither budget <i>C</i> or desired result <i>B</i> fixed.	Select alternative per benefit-cost ratio incremental analysis (sec. 2.2.3, step 11).

- (4) Identify the cost or savings for each alternative. The cost should include such items as initial investment, and ongoing operating and maintenance expenses (including depreciation) for the life of the system. The savings should include such items as residual or salvage values, etc.<sup>2,3</sup>
- (5) Identify the benefit or detriments for each alternative. The benefits might include such items as increased performance, reduced operating times, compressed schedules, increased reliability, increased safety, value added due to increase productivity, etc. The detriments might include such items as loss of production time, increased schedules, increased equipment operating costs, environmental impacts, reduced property value, etc.<sup>2,3</sup> The cost risk and technical maturity for each alternative may be included as a multiplying factor (*f*) for this analysis. Since it is subjective, use of only three factors—0.5, 0.75, or 1—is probably as fine a distinction as is warranted.
- (6) Specify the time interval (expected operating life of the system) to which the analysis is to apply.

- (7) Develop cost and savings estimates and the benefits and detriments estimates for each alternative.<sup>2,3</sup> The estimates for each alternative should be for the same time interval specified in step 6. Every attempt should be made to base cost and savings estimates on actual historical cost data.
- (8) Identify the interest rate that will be assumed for the analysis.<sup>2,3</sup> Convert all costs, savings, benefits, and detriments estimates to present worth values.<sup>2,5</sup>
- (9) Determine the total cost for each alternative by algebraically summing all costs as positive values and all savings as negative values.
- (10) Determine the total benefit value for each alternative by algebraically summing all benefits as positive values and all detriments as negative values.
- (11) Calculate the  $B/C$  ratio for each alternative by dividing the total benefit ( $B$ ) by the total cost ( $C$ ).

For cases with fixed cost restraints or fixed desired results or benefits, perform step 12.<sup>2,5</sup>

- (12) Rank the alternatives relative to their respective cost-to-benefit ratios, and select the superior alternative based on selection criteria established in step 3.

For cases with cost restraints and desired results or benefits that vary, perform steps 13 through 17.<sup>2,5</sup>

- (13) If there exists any alternatives with a  $B/C \geq 1$ , then do not give further consideration to alternatives with a  $B/C < 1$ .
- (14) Order the remaining alternatives in sequence of increasing total  $C$ .
- (15) Determine the incremental  $B/C$  ratio  $\Delta B/C$  for each consecutive pair of alternatives with increasing total cost.

$$\Delta B/C_i = \Delta B_i / \Delta C_i, \text{ where } \Delta B_i = B_{i+1} - B_i \text{ and } \Delta C_i = C_{i+1} - C_i$$

for each  $i^{\text{th}}$  pair of  $(n - 1)$  pairs of  $n$  alternatives where alternative  $i = 1, 2, \dots, n$  listed in order of  $C$ .

- (16) Next, examine each distinct increment of increased cost investment. If the  $\Delta B/C_i$  is  $< 1$ , then the increment is not beneficial. If the  $\Delta B/C_i$  is  $> 1$ , then the increment is beneficial.
- (17) The preferred alternative is the last alternate listed in order of increasing cost whose incremental  $\Delta B/C_i$  is  $> 1$ . Therefore, the preferred alternative may not necessarily have the greatest  $B/C$  ratio.

#### 2.2.4 Example

##### Problem:

Five data acquisition systems (DAS) are under consideration to acquire data for solid rocket motor tests in a test stand over a 10-yr time interval. Each system has a different total cost and the capabilities of each system are different in terms of maximum number of channels, maximum sample

rates, required maintenance, data accuracy, turnaround time between tests, and mean time between system failures. The present value of the estimated total cost and total value of combined benefits of the system are presented below. The present values of cost and benefits were determined over a 10-yr expected system life, with an assumed annual interest rate of 10 percent. Perform a cost-versus-benefit analysis to determine the best alternative.

<u>System</u>	<u>A</u>	<u>B</u>	<u>C</u>	<u>D</u>	<u>E</u>
Total cost (dollars)	500k	300k	750k	800k	400k
Total benefits (dollars)	750k	400k	900k	750k	600k
<i>B/C</i>	1.50	1.33	1.20	0.93	1.50

Solution:

Step 1. Delete options with a *B/C* ratio  $<1$ . Since the *B/C* for system *D* is  $<1$ , this option will no longer be considered.

Step 2. List the remaining options in order of increasing total cost.

<u>System</u>	<u>B</u>	<u>E</u>	<u>A</u>	<u>C</u>
Total cost (dollars)	300k	400k	500k	750k
Total benefits (dollars)	400k	600k	750k	900k

Step 3. Determine the incremental *B/C* ratio  $\Delta B/C$  for each consecutive pair of alternatives with increasing total cost.

<u>Increment</u>	<u>E-B</u>	<u>A-E</u>	<u>C-A</u>
$\Delta$ Total cost (dollars)	100k	100k	250k
$\Delta$ Total benefits (dollars)	200k	150k	150k
$\Delta B/C$	2.0	1.5	0.6

Step 4. Identify the preferred alternative as the last alternate listed in order of increasing cost whose incremental  $\Delta B/C_i$  is  $>1$ .

By inspection, the last incremental  $\Delta B/C$  with a value  $>1$  is A-E. Therefore, the preferred alternative is DAS A.

### 2.2.5 Advantages

The following advantages are realized by performing cost-versus-benefit analyses:

- (1) The analyst can assess the cost effectiveness of several alternatives over the entire life cycle of the proposed system under consideration.
- (2) The method provides a clearly documented analysis in which the prioritized objectives/requirements, the alternatives considered, and the selection methodology are recorded.

### 2.2.6 Limitations

Cost-versus-benefit analyses possess the following limitations:

- (1) The analysis is flawed if system requirements are incomplete or inadequate. If the system operating environment is not understood or accurately characterized, the total costs can be underestimated. If the system requirements are too general or vague, benefits cannot be addressed in specific, measurable terms of effectiveness.<sup>2.5</sup>
- (2) The analysis is only as good as the list of alternatives considered. An incomplete list of alternatives will lead to an incomplete analysis.<sup>2.6</sup>
- (3) The analysis is flawed if incomplete or inaccurate cost estimates are used.<sup>2.6</sup>
- (4) The analyst must be able to quantify the value of benefits, which are often intangible or insubstantial and difficult to characterize in terms of monetary value.<sup>2.3</sup>
- (5) The analysis does not take into account technical complexity or maturity of an alternative, except as a cost uncertainty factor. Further, system reliability and safety issues are not treated except by the selection of the alternative. As cost is generally only one of many factors, this tool is generally insufficient for selection of large, new design efforts, but more appropriate to production-level design solutions.

### 2.2.7 Bibliography

Thuesen, G.J., and Fabrycky, W.J.: "Engineering Economy." Seventh edition, Englewood Cliffs, Prentice Hall, New Jersey, 1989.



## REFERENCES

- 2.1 “System Engineering Management Guide.” Defense Systems Management College, January 1990.
- 2.2 Saaty, T.L.: “Priority Setting in Complex Problems.” IEEE Transactions, pp. 140–155, August 1983.
- 2.3 Jelen, F.C., and Black, J.H.: “Cost and Optimization Engineering.” Second edition, New York, McGraw-Hill Book Company, 1983.
- 2.4 Beattie, C.J., and Reader, R.D.: “Quantitative Management in R & D.” London, Chaplin and Hall Ltd., 1971.
- 2.5 Newnan, D.G.: “Engineering Economic Analysis.” Second edition, Engineering Press, Inc., San Jose, California, 1983.
- 2.6 Chestnut, H.: “System Engineering Methods.” John Wiley & Sons Inc., New York, 1967.

### 3. SYSTEM SAFETY AND RELIABILITY TOOLS

This section describes several system safety and reliability tools available to the system engineer analyst. The risk assessment matrix is discussed in section 3.1. This device supports a standard methodology to subjectively evaluate hazards as to their risks. It is used in conjunction with hazard analyses, such as the preliminary hazard analysis (PHA) technique discussed in section 3.2. The PHA can be used to identify hazards and to guide development of countermeasures to mitigate the risk posed by these hazards. The energy/flow barrier analysis discussed in section 3.3 is also a technique to identify hazards and to evaluate their corresponding countermeasures.

Once hazards are identified, they can be further explored if failure modes of the elements of the system are known. The failure modes and effects analysis (FMEA), discussed in section 3.4, can be used to identify failure modes and their consequences or effects. Also discussed in section 3.4 is the failure modes, effects, and criticality analysis (FMECA). The FMECA is similar to the FMEA but also addresses the criticality, or risk, associated with each failure mode.

Several symbolic logic methods are presented in this section. These methods construct conceptual models of failure or success mechanisms within a system. These tools are also used to determine either the probability of failures occurring or the probability that a system or component will operate successfully. The probability of a successful operation is the reliability. If the probability of failure ( $P_F$ ) is examined, then the model is generated in the failure domain and if the probability of success ( $P_S$ ) is examined, then the model is generated in the success domain. For convenience, the analyst can model either in the failure or success domain (or both domains), then convert the final probabilities to the desired domain using the following expression:  $P_F + P_S = 1$ .

These models are developed using forward (bottom-up) or backwards (top-down) logic. When using forward logic the analyst builds the model by repeatedly asking, "What happens when a given failure occurs?" The analyst views the system from a "bottom-up" perspective. This means he starts by looking at the lowest level elements in the system and their functions. Classically, the FMEA, for example, is a bottom-up technique. When using backwards logic to build a model, the analyst repeatedly asks, "What will cause a given failure to occur?" The analyst views the system from a "top-down" perspective. This means he starts by looking at a high level system failure and proceeds down into the system to trace failure paths. The symbolic logic techniques discussed in this section and their characteristics are presented in table 3-1.

Each of the symbolic logic techniques has its own unique advantages and disadvantages. Sometimes it is beneficial to construct a model using one technique, then transform that model into the domain of another technique to exploit the advantages of both techniques. Fault trees are generated in the failure domain, reliability diagrams are generated in the success domain, and event trees are generated both in the success and failure domains. Methods are presented in section 3.9 to transform any one of the above models into the other two by translating equivalent logic from the success to failure or failure to success domains.

Probabilities are propagated through the logic models to determine the probability that a system will fail or the probability the system will operate successfully, i.e., the reliability. Probability data may be derived from available empirical data or found in handbooks. If quantitative data are not available, then subjective probability estimates may be used as described in section 3.12. Caution must be exercised when quoting reliability numbers. Use of confidence bands is important. Often the value is in a comparison of numbers that allows effective resource allocation, rather than "exact" determination of

Table 3-1. Symbolic logic techniques.

Technique	Section	Success Domain	Failure Domain	Forward (Bottom-Up)	Backwards (Top-Down)
Reliability block diagram	3.5	√			√
Fault tree analysis	3.6		√		√
Success tree analysis	3.7	√			√
Event tree analysis	3.8	√	√	√	
Cause-consequence analysis	3.10	√	√	√	√
Directed graph matrix analysis	3.11	√	√		√

expected reliability levels. Probabilistic design analysis (PDA) is discussed in section 3.14. This technique uses advanced statistical methods to determine  $P_F$  modes.

Failure mode information propagation modeling is discussed in section 3.13. This technique allows the analyst to determine what information is needed, and how and where the information should be measured in a system to detect the onset of a failure mode that could damage the system.

Finally, probabilistic risk assessment (PRA) is discussed in section 3.15. This is a general methodology that shows how most of the techniques mentioned above can be used in conjunction to assess risk with severity and probability.

A summary of the major advantages and limitations of each tool or methodology discussed in this section is presented in table 3-2.

### 3.1 Risk Assessment Matrix

#### 3.1.1 Description

The risk assessment matrix, as described in reference 3.1, is a tool to conduct subjective risk assessments for use in hazard analysis. The definition of risk and the principle of the iso-risk contour are the basis for this technique.

Risk for a given hazard can be expressed in terms of an expectation of loss, the combined severity and probability of loss, or the long-term rate of loss. Risk is the product of severity and probability (loss events per unit time or activity). Note: the probability component of risk must be attached to an exposure time interval.

The severity and probability dimensions of risk define a risk plane. As shown in figure 3-1, iso-risk contours depict constant risk within the plane.

Table 3-2. System safety and reliability tools and methodologies—Continued

Tool or Methodology	Section	Advantages	Limitations
Risk assessment matrix	3.1	Provides standard tool to subjectively assess risk.	Only used to assess risk of hazards, does not identify hazards.
Preliminary hazard analysis	3.2	Identifies and provides inventory of hazards and countermeasures.	Does not address coexisting system failure modes.
Energy flow/barrier analysis	3.3	Identify hazards associated with energy sources and determines if barriers are adequate countermeasures.	(1) Does not address coexisting system failure modes. (2) Fails to identify certain classes of hazards, e.g., asphyxia in oxygen-deficient confined spaces.
Failure modes and effects (and criticality) analysis	3.4	Thorough methods of identifying single point failures and their consequences. A criticality analysis provides a risk assessment of these failure modes.	Can be extremely labor intense. Does not address coexisting system failure modes.
Reliability block diagram	3.5	A symbolic logic model that is relatively easy for the analyst to construct. System reliability can be derived, given component reliability.	Component reliability estimates may not be readily available; total calculated reliability may be unrealistically high.
Fault tree analysis	3.6	(1) Enables assessment of probabilities of coexisting faults or failures. (2) May identify unnecessary design elements.	(1) Addresses only one undesirable event or condition that must be foreseen by the analyst. (2) Comprehensive trees may be very large and cumbersome.
Success tree analysis	3.7	Assesses probability of favorable outcome of system operation.	(1) Addresses only one desirable event or condition that must be foreseen by the analyst. (2) Comprehensive trees may be very large and cumbersome.
Event tree analysis	3.8	(1) Enables assessment of probabilities of coexisting faults or failures. (2) Functions simultaneously in failure and success domain. (3) End events need not be anticipated. Accident sequences through a system can be identified.	(1) Addresses only one initiating challenge that must be foreseen by the analyst. (2) Discrete levels of success and failure are not distinguishable.
Fault tree, reliability, block diagram, and event tree transformations	3.9	Allows the analyst to overcome weakness of one technique by transforming a model of a system into an equivalent logic model in another analysis technique.	This technique offers no additional information and is only as good as the input model.

Table 3-2. System safety and reliability tools and methodologies—Continued.

Tool or Methodology	Section	Advantages	Limitations
Cause-consequence analysis	3.10	<ul style="list-style-type: none"> <li>(1) Enables assessment of probabilities of coexisting faults or failures.</li> <li>(2) End events need not be anticipated.</li> <li>(3) Discrete levels of success and failure are distinguishable.</li> </ul>	<ul style="list-style-type: none"> <li>(1) Addresses only one initiating challenge that must be foreseen by the analyst.</li> <li>(2) May be very subjective as to consequence severity.</li> </ul>
Directed graph (digraph) matrix analysis	3.11	<ul style="list-style-type: none"> <li>(1) Allows the analyst to examine the fault propagation through several primary and support systems.</li> <li>(2) Minimal cut sets, single-point failure, and double point failures can be determined with less computer computation than with FTA.</li> </ul>	<ul style="list-style-type: none"> <li>(1) Trained analyst and computer codes and resources to perform this technique may be limited.</li> <li>(2) Only identifies single point (singleton) and dual points (doubleton) of failure.</li> </ul>
Combinatorial failure probability analysis using subjective information	3.12	Allows analyst to perform qualitative probabilistic risk assessment based on the exercise of subjective engineering judgment when no quantitative data is available.	Use of actual quantitative data is preferred to this method. Should only be used when actual quantitative failure data is unavailable.
Failure mode information propagation modeling	3.13	Measurement requirements can be determined that if implemented can help safeguard a system in operation by providing warning at the onset of a threatening failure mode.	<ul style="list-style-type: none"> <li>(1) This technique is only applicable if the system is operating in a near normal range and for the instant of time just before initiation of a failure.</li> <li>(2) Data and results, unless used in a comparative fashion, may be poorly received.</li> </ul>
Probabilistic design analysis	3.14	<ul style="list-style-type: none"> <li>(1) Allows the analyst a practical method of quantitatively and statistically estimating the reliability of a system during the design phase.</li> <li>(2) Provides alternative to the traditional method of imposing safety factors and margins to ensure system reliability. That method might be flawed if significant experience and historical data of similar components are not available.</li> </ul>	<ul style="list-style-type: none"> <li>(1) Analyst must have significant experience in probability and statistical methods to apply this technique.</li> <li>(2) Historical population data used must very close to as-planned design population to be viable. Extrapolation between populations can render technique nonviable.</li> </ul>
Probabilistic risk assessment	3.15	Provides methodology to assess overall system risks; avoids accepting unknown, intolerable, and senseless risk.	Performing the techniques of this methodology requires skilled analysts. Techniques can be misapplied and results misinterpreted.

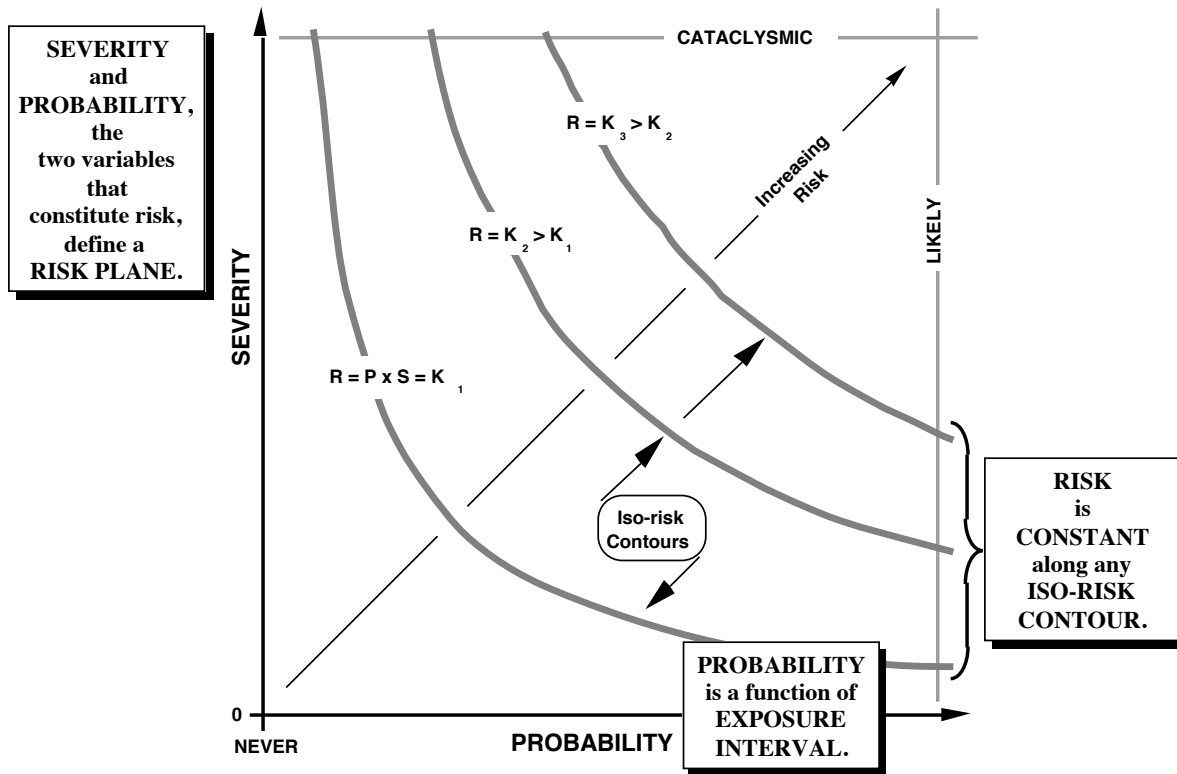

Figure 3-1. Risk plane.

The concept of the iso-risk contour is useful to provide guides, convention, and acceptance limits for risk assessments (fig. 3-2).

Risk should be evaluated for worst *credible* case, not worst conceivable case, conditions. Failure to assume credible (even if conceivable is substituted) may result in an optimistic analysis; it will result in a nonviable analysis.

### 3.1.2 Application

The risk assessment matrix is typically performed in phase C but may also be performed in phase A. This technique is used as a predetermined guide or criteria to evaluate identified hazards as to their risks. These risks are expressed in terms of severity and probability. Use of this tool allows an organization to institute and standardize the approach to perform hazard analyses. The PHA, defined in section 3.2, is such an analysis.

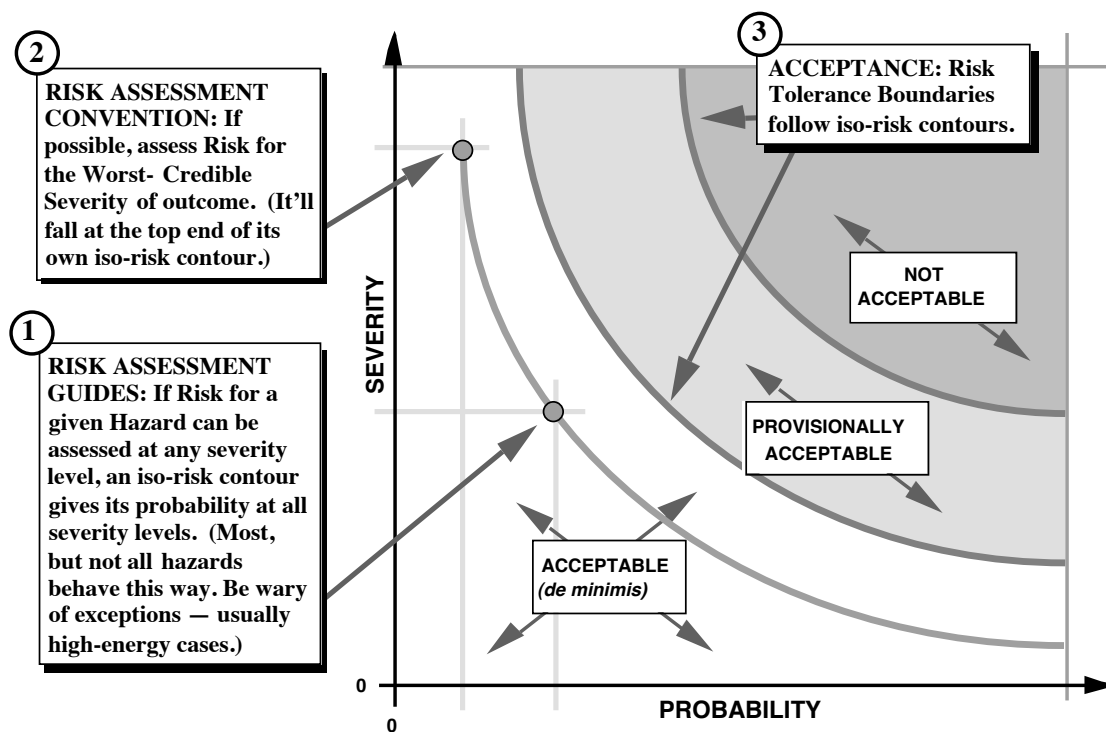

Figure 3-2. Iso-risk contour usage.

### 3.1.3 Procedures

Procedures, as described in reference 3.1, for developing a risk assessment matrix are presented below:

- (1) Categorize and scale the subjective probability levels for all targets, such as frequent, probable, occasional, remote, improbable, and impossible (adapted from MIL-STD-882C).<sup>3,2</sup> Note: A target is defined as the “what” which is at risk. One typical breakout of targets is personnel, equipment, downtime, product loss, and environmental effects.
- (2) Categorize and scale the subjective severity levels for each target, such as catastrophic, critical, marginal, and negligible.
- (3) Create a matrix of consequence severity versus the probability of the mishap. Approximate the continuous, iso-risk contour functions in the risk plane with matrix cells (fig. 3-3). These matrix cells fix the limits of risk tolerance zones. Note that not the analyst but management establishes and approves the risk tolerance boundaries.
- (4) The following hints will be of help when creating the matrix:
  - a. Increase adjacent probability steps by orders of magnitude. The lowest step, “impossible,” is an exception (fig. 3-4(a)).
  - b. Avoid creating too many matrix cells. Since the assessment is subjective, too many steps add confusion with no additional resolution (fig. 3-4(b)).

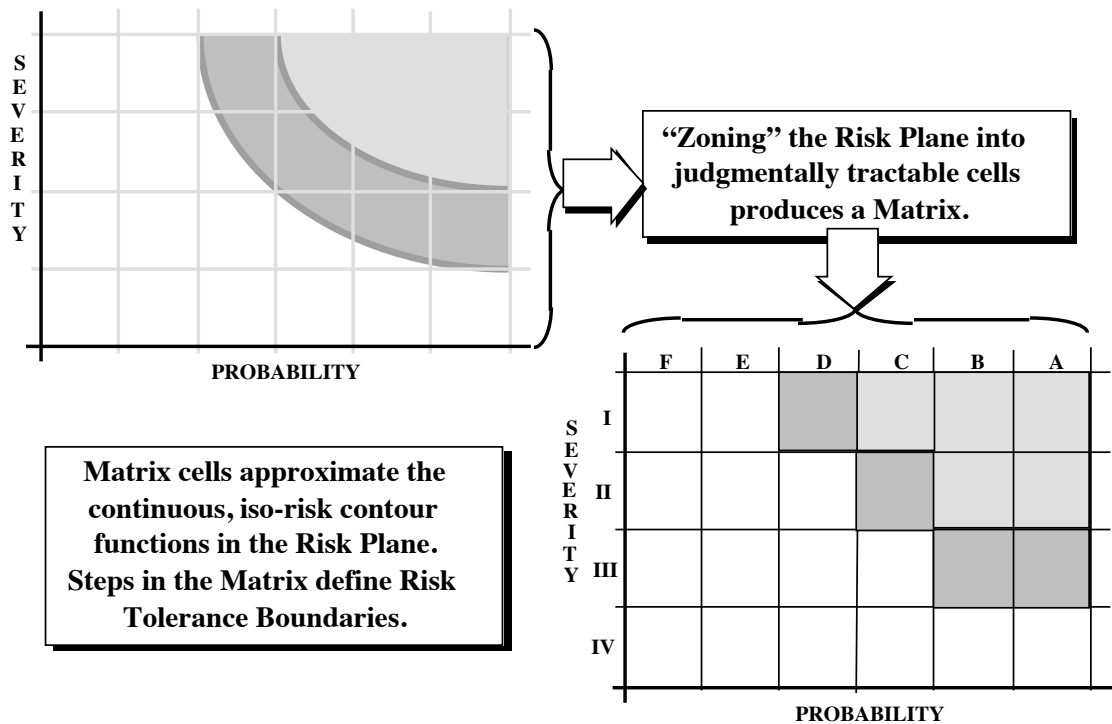

Figure 3-3. Risk plane to risk matrix transformation.

- c. Avoid discontinuities in establishing the risk zones, i.e., make sure every one-step path does not pass through more than one zone (fig. 3-4(c)).
  - d. Establish only a few risk zones. There should only be as many zones, as there are desired categories of resolution to risk issues, i.e., (1) unacceptable, (2) accepted by waiver, and (3) routinely accepted (fig. 3-4(d)).
- (5) Calibrate the risk matrix by selecting a cell and attaching a practical hazard scenario to it. The scenario should be familiar to potential analysts or characterize a tolerable perceivable threat. Assign its risk to the highest level severity cell just inside the acceptable risk zone. This calibration point should be used as a benchmark to aid in evaluating other, less familiar risks.



**Factors of 10 separate adjacent Probability Steps.**

$D = 10 \times E$   
 $C = 10 \times D$   
 $B = 10 \times C$   
 $A = 10 \times B$   
 ...but  $F = 0$  ("Impossible")

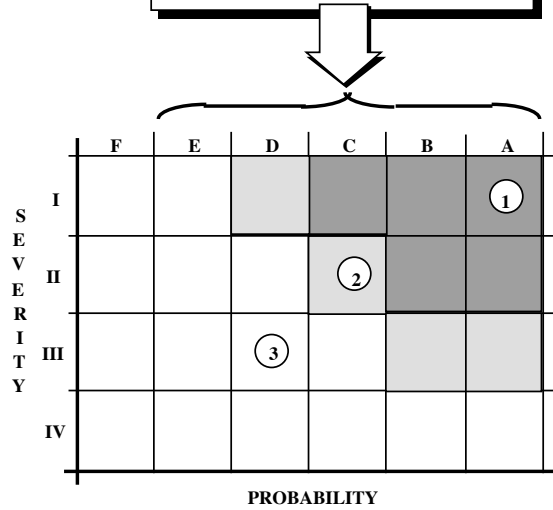

(a) Useful conventions.

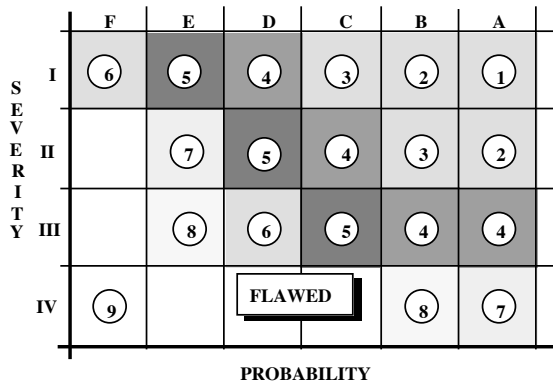

A 24-cell Matrix can be resolved into 9 levels of "priority," or even more. But what are the rational functions for the many levels?

Three zones will usually suffice. A Hazard's Risk is either...

- (3) Routinely Accepted
- (2) Accepted by Waiver, or
- (1) Avoided.

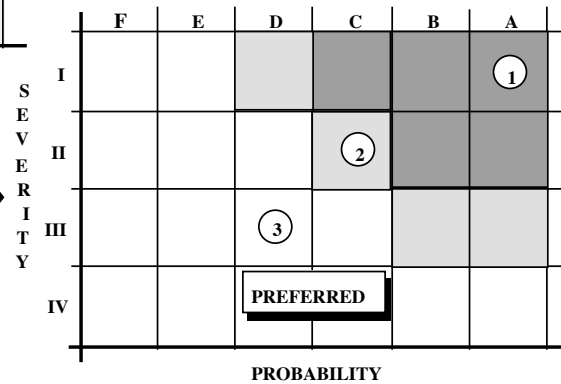

(b) Do not create too many cells.

Figure 3-4. Helpful hints in creating a risk assessment matrix—Continued

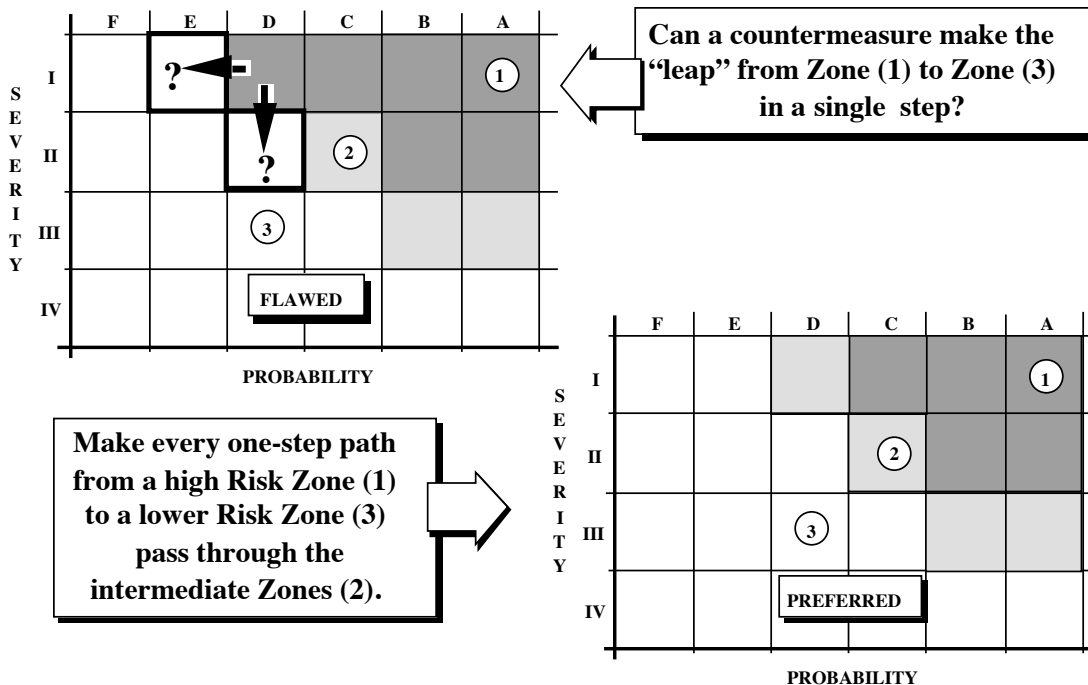

(c) Avoid discontinuities.

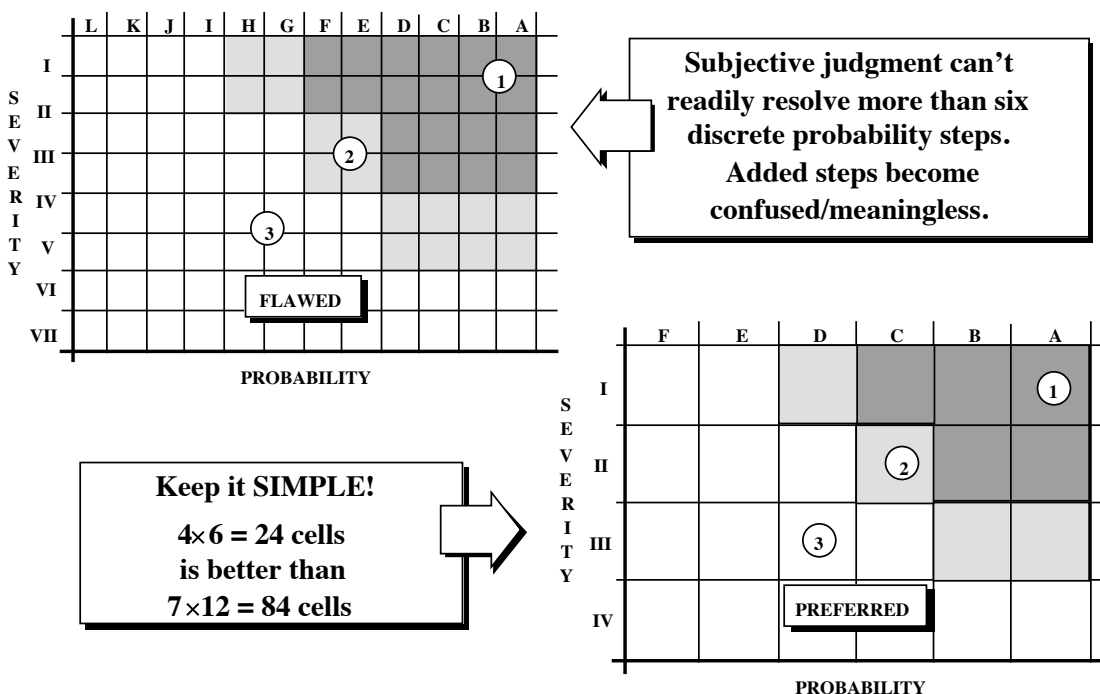

(d) Do not create too many zones.

Figure 3-4. Helpful hints in creating a risk assessment matrix—Continued.

### 3.1.4 Example

A typical risk assessment matrix, adapted from MIL-STD-882C,<sup>3,2</sup> is presented in figure 3-5. Example interpretations of the severity and probability steps for this matrix are presented in figure 3-6.

Severity of Consequences	Probability of Mishap**					
	F IMPOSSIBLE	E IMPROBABLE	D REMOTE	C OCCASIONAL	B PROBABLE	A FREQUENT
I CATASTROPHIC					①	
II CRITICAL				②		
III MARGINAL			③			
IV NEGLIGIBLE						

Risk Code/	Actions
①	Imperative to suppress risk to lower level.
②	Operation requires written, time-limited waiver, endorsed by management.
③	Operation permissible.

**NOTE** Personnel must not be exposed to hazards in Risk Zones 1 and 2.

\*Adapted from MIL-STD-882C    \*\*Life Cycle = 25 yrs.

Figure 3-5. Typical risk assessment matrix.

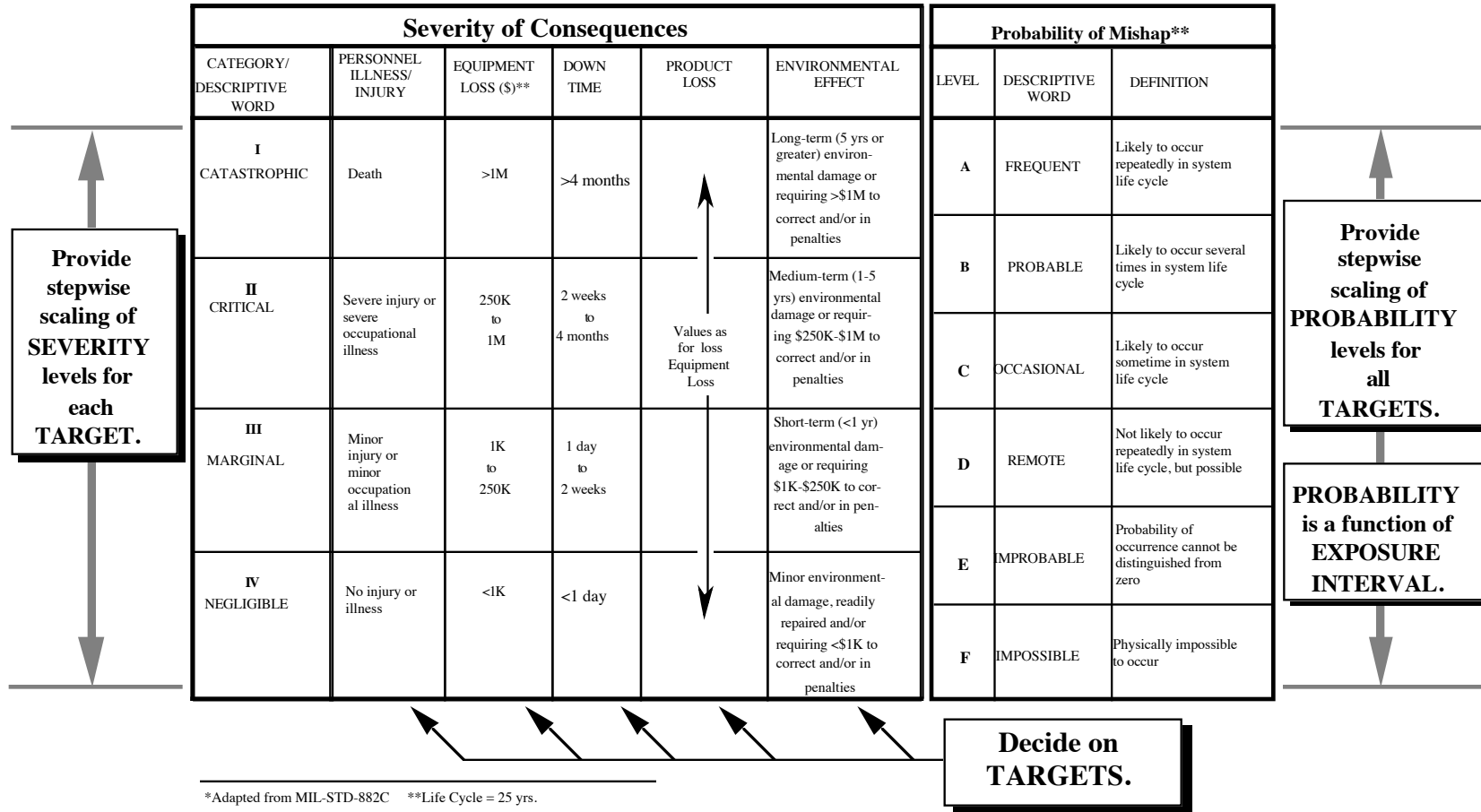

Figure 3-6. Severity and probability interpretations.

### 3.1.5 Advantages

The risk assessment matrix provides the following advantages:<sup>3.1</sup>

- (1) The risk matrix provides a useful guide for prudent engineering.
- (2) The risk matrix provides a standard tool of treating the relationship between severity and probability in assessing risk for a given hazard.
- (3) Assessing risk subjectively avoids unknowingly accepting intolerable and senseless risk, allows operating decisions to be made, and improves resource distribution for mitigation of loss resources.

### 3.1.6 Limitations

The risk assessment matrix possesses the following limitations:<sup>3.1</sup>

- (1) The risk assessment matrix can only be used if hazards are already identified. This tool does not assist the analyst in identifying hazards.
- (2) This method is subjective without data and is a comparative analysis only.

### 3.1.7 Bibliography

Code of Federal Regulations, Medical devices, "Pre-Market Notification." sec. 807.90, vol. 21.

Code of Federal Regulations, "Process Safety Management of Highly Hazardous Chemicals." sec. 1910.119 (e), vol. 29.

Department of Defense Instruction, No. 5000.36. "System Safety Engineering & Management."

NASA NHB 1700.1, vol. 3, "System Safety."

NUREG/GR-0005. "Risk-Based Inspection – Development of Guidelines."

## **3.2 Preliminary Hazard Analysis**

### 3.2.1 Description

A PHA, as described in reference 3.3, produces a line item tabular inventory of nontrivial system hazards, and an assessment of their remaining risk after countermeasures have been imposed. This inventory includes qualitative, not quantitative, assessments of risks. Also, often included is a tabular listing of countermeasures with a qualitative delineation of their predicted effectiveness. A PHA is an early or initial system safety study of system hazards.

### 3.2.2 Application

PHA's are best applied in phase C but may also be applied in phase B. This tool is applied to cover whole-system and interface hazards for all mission phases. A PHA may be carried out, however, at any point in the life cycle of a system. This tool allows early definition of the countermeasure type and incorporation of design countermeasures as appropriate.

### 3.2.3 Procedures

A flowchart describing the process to perform a PHA is presented in figure 3-7. Procedures for performing PHA's, as described in reference 3.3, are presented below:

- (1) Identify resources of value, such as personnel, facilities, equipment, productivity, mission or test objectives, environment, etc. to be protected. These resources are targets.
- (2) Identify and observe the levels of acceptable risk that have been predetermined and approved by management. These limits may be the risk matrix boundaries defined in a risk assessment matrix (sec. 3.1).
- (3) Define the extent of the system to be assessed. Define the physical boundaries and operating phases (such as shakedown, activation, standard operation, emergency shutdown, maintenance, deactivation, etc.). State other assumptions, such as if the assessment is based on an as-built or as-designed system, or whether current installed countermeasures will be considered.
- (4) Detect and confirm hazards to the system. Identify the targets threatened by each hazard. A hazard is defined as an activity or circumstance posing "a potential of loss or harm" to a target and is a condition required for an "undesired loss event."<sup>3.3</sup> Hazards should be distinguished from consequences and considered in terms of a source (hazard), mechanism (process), and outcome (consequence). A team approach to identifying hazards, such as brainstorming (sec. 7.7), is recommended over a single analyst. If schedule and resource restraints are considerations, then a proficient engineer with knowledge of the system should identify the hazards, but that assessment should be reviewed by a peer. A list of proven methods\* for finding hazards is presented below:
  - a. Use intuitive "engineering sense."
  - b. Examine and inspect similar facilities or systems and interview workers assigned to those facilities or systems.
  - c. Examine system specifications and expectations.
  - d. Review codes, regulations, and consensus standards.
  - e. Interview current or intended system users or operators.
  - f. Consult checklists (app. D).
  - g. Review system safety studies from other similar systems.

---

\*Provided courtesy of Sverdrup Technology, Inc., Tullahoma, Tennessee.<sup>3.3</sup>

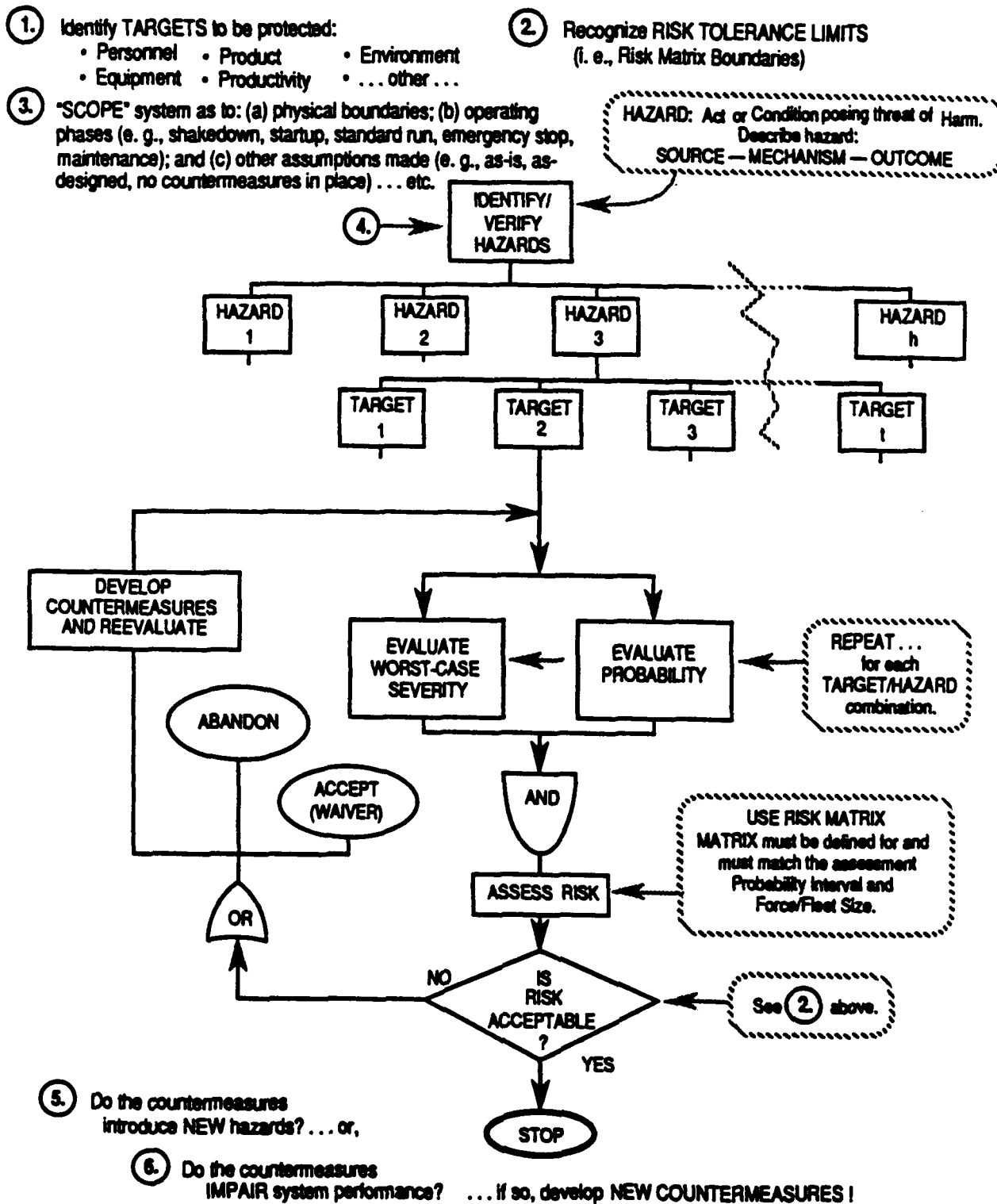

Figure 3-7. PHA Process flowchart

- h. Review historical documents—mishap files, near-miss reports, OSHA-recordable injury rates, National Safety Council data, manufacturer’s reliability analyses, etc.
  - i. Consider “external influences” like local weather, environment, or personnel tendencies.
  - j. Consider all mission phases.
  - k. Consider “common causes.” A common cause is a circumstance or environmental condition that, if it exists, will induce two or more fault/failure conditions within a system.
  - l. Brainstorm (sec. 7.7)—mentally develop credible problems and play “what-if” games.
  - m. Consider all energy sources. What is necessary to keep them under control; what happens if they get out of control?
- (5) Assess worst-credible case (not the worst-conceivable case) severity and probability for each hazard and target combination. Keep the following considerations in mind during the evaluation:
- a. Remember that severity for a specific hazard varies as a function of targets and operational phases.
  - b. A probability interval must be established before probability can be determined. This interval can be in terms of time, or number of cycles or operations.
  - c. The assessment will underestimate the true risk if a short-term probability interval is used unless the risk acceptance criterion is adjusted accordingly. Probability intervals expressed in hours, days, weeks, or months are too brief to be practical. The interval should depict the estimated facility, equipment, or each human operator working life span. An interval of 25 to 30 yr is typically used and represents a practical value.
  - d. The probability for a specific hazard varies as a function of exposure time, target, population, and operational phase.
  - e. Since probability is determined in a subjective manner, draw on the experience of several experts as opposed to a single analyst.
- (6) Assess risk for each hazard using a risk assessment matrix (sec. 3.1). The matrix should be consistent with the established probability interval and force or fleet size for this assessment.
- (7) Categorize each identified risk as acceptable or unacceptable, or develop countermeasures for the risk, if unacceptable.
- (8) Select countermeasures in the following descending priority order to optimize effectiveness: (1) “design change,” (2) “engineering safety systems,” (3) “safety devices,” (4) “warning devices,” and (5) “procedures and training.”<sup>3.3</sup>



Note that this delineation, while in decreasing order of effectiveness, is also typically in decreasing order of cost and schedule impact (i.e., design changes have the highest potential for cost and schedule impact). A trade study (sec. 2.1) might be performed to determine a countermeasure of adequate effectiveness and minimized program impact.

- (9) Reevaluate the risk with the new countermeasure installed.
- (10) If countermeasures are developed, determine if they introduce new hazards or intolerably diminish system performance. If added hazards or degraded performance are unacceptable, determine new countermeasures and reevaluate the risk.

### 3.2.4 Example

An example of a completed PHA worksheet<sup>3,3</sup> for a pressurized chemical intermediate transfer system is presented in figure 3-8. (A blank form is included in appendix E.)

Preliminary Hazard Analysis								
Brief Descriptive Title (Portion of System/Sub-system/Operational Phases covered by this analysis): Pressurized UnFo <sub>3</sub> Containment and Replenishment Reservoir and Piping / Startup, Routine Operation, Standard Stop, Emergency Shutdown								
Probability Interval: 25 years	Date: 25 Feb. 1993	Hazard Target* Severity Probability Risk Code	Risk Before Severity Probability Risk Code	Description of Countermeasures Identify countermeasures by appropriate code letter(s): D = Design Alteration      E = Engineered Safety Feature S = Safety Device          W = Warning Device P = Procedures/Training	Risk After Severity Probability Risk Code			
System Number: Srd-A (Chem/Int)	Analysis: <input checked="" type="checkbox"/> Initial Revision <input type="checkbox"/> Addition <input type="checkbox"/>							
Hazard No. / Description								
Srd-A.a.042 — Flange Seal A-29 leakage, releasing pressurized UnFo <sub>3</sub> chemical intermediate from containment system, producing toxic vapors and attacking nearby equipment.		P	I	D	2	I	E	3
		E	II	C	2	II	D	3
		T	III	C	3	III	D	3
<p>Show hazard alphanumeric designator. Describe hazard source mechanism, worst-credible outcome.</p> <p>Identify target(s).</p> <p>Assess worst-credible Severity, and Probability for that outcome. Show Risk (from assessment matrix) for hazard "as-is" — i.e., with no added countermeasures.</p>				<p>Describe newly proposed countermeasures to reduce Probability/Severity. NOTE: THESE COUNTERMEASURES MUST BE IN PLACE PRIOR TO OPERATION.</p>		<p>Reassess Probability/Severity, and show Risk (from assessment matrix) for hazard, presuming new countermeasures to be in place. If Risk is not acceptable, new countermeasures must be developed.</p>		
Prepared by/Date:		*Target Codes: P—Personnel T—Downtime		E—Equipment R—Product V—Environment		Approved by/Date:		

Figure 3-8. Typical PHA.

Note that the worksheet from this example contains the following information:

- a. Brief description of the portion of the system, subsystem, or operation covered in the analysis.
- b. Declaration of the probability interval.
- c. System number.
- d. Date of analysis.
- e. Hazard (description and identification number).
- f. Hazard targets (check boxes for personnel, equipment, downtime, product environment).
- g. Risk assessment before countermeasures are considered; including severity level, probability level, and risk priority code (zone from risk matrix, fig. 3-5).
- h. Description of countermeasure (with codes for various types).
- i. Risk assessment after countermeasures are considered, including severity level, probability level, and risk priority code.
- j. Signature blocks for the analyst and reviewers/approvers.

The PHA worksheet used in the example is typical. However, an organization may create their own worksheet customized for their operation. For example, different target types may be listed. In any case, great care should be given in designing the form to encourage effective usage. Although helpful, a PHA is not a structured approach that assists the analyst in identifying hazards or threats.

### 3.2.5 Advantages

A PHA provides the following advantages:<sup>3.3</sup>

- (1) Identifies and provides a log of primary system hazards and their corresponding risks.
- (2) Provides a logically based evaluation of a system's weak points early enough to allow design mitigation of risk rather than a procedural or inspection level approach.
- (3) Provides information to management to make decisions to allocate resources and prioritize activities to bring risk within acceptable limits.
- (4) Provides a relatively quick review and delineation of the most significant risks associated with a specific system.

### 3.2.6 Limitations

A PHA possesses the following limitations:<sup>3.3</sup>

- (1) A PHA fails to assess risks of combined hazards or coexisting system failure modes. Therefore a false conclusion may be made that overall system risk is acceptable simply because each hazard element risk identified, when viewed singularly, is acceptable.
- (2) If inappropriate or insufficient targets or operational phases are chosen, the assessment will be flawed. While on the other hand, if too many targets or operational phases are chosen, the effort will become too large and costly to implement.

### 3.2.7 Bibliography

Air Force Systems Command Design Handbook DH 1-6, "System Safety." December 1982.

Army Regulation 3895-16, "System Safety Engineering and Management." May 1990.

Browning, R.L.: "The Loss Rate Concept in Safety Engineering." Marcel Dekker, Inc., 1980.

Hammer, W.: "Handbook of System and Product Safety." Prentice-Hall, Inc., 1972.

Henley, E.J., and Kumamoto, H.: "Probabilistic Risk Assessment." The Institute of Electrical and Electronic Engineers, Inc., New York, 1991.

Malasky, S.W.: "System Safety: Technology and Application." Garland STPM Press, 1982.

Raheja, D.G. "Assurance Technology and Application - Principles and Practices." McGraw-Hill, 1991.

Roland, H.E., and Moriarty, B.: "System Safety Engineering and Management." John Wiley & Sons, Inc., 1983.

## **3.3 Energy Flow/Barrier Analysis**

### 3.3.1 Description

The energy flow/barrier analysis, as described in reference 3.4, is a system safety analysis tool, used to identify hazards and determine the effectiveness of countermeasures employed or suggested to mitigate the risk induced by these hazards. This tool is also known as energy trace/barrier analysis. The energy flow/barrier method is a useful supplement to the PHA discussed in section 3.2.

Energy sources such as electrical, mechanical, chemical, radiation, etc., are identified. Opportunities for undesired energy flow between the sources and targets are assessed. Barriers are countermeasures against hazards caused by flows from these energy sources to targets. Examples of barriers include barricades, blast walls, fences, lead shields, gloves, safety glasses, procedures, etc.

### 3.3.2 Application

An energy flow/barrier analysis can be beneficially applied whenever assessments are needed to assure an identified target is being safeguarded against a potential energy source that can impose harm. This assessment can be applied during phase C but may also be applied in phase E or phase B. This analysis can also be applied in failure investigations.

### 3.3.3 Procedures

Procedures to perform an energy flow/barrier analysis, as described in reference 3.4, are presented below:

- (1) Examine the system and identify all energy sources.
- (2) Examine each potential energy flow path in the system. Consider the following for each energy flow path:
  - a. What are the potential targets, such as personnel, facilities, equipment, productivity, mission or test objectives, environment, etc.? Remember every energy source could have multiple flow paths and targets.
  - b. Is the energy flow unwanted or detrimental to a target?
  - c. Are existing barriers sufficient countermeasures to mitigate the risk to the targets?
- (3) Consider the following strategies extracted from reference 3.4 to control harmful energy flow:
  - a. Eliminate energy concentrations.
  - b. Limit quantity and/or level of energy.
  - c. Prevent the release of energy.
  - d. Modify the rate of release of energy.
  - e. Separate energy from target in time and/or space.
  - f. Isolate by imposing a barrier.
  - g. Modify target contact surface or basic structure.
  - h. Strengthen potential target.
  - i. Control improper energy input.

### 3.3.4 Example

Examples of strategies to manage harmful energy flows are presented in table 3-3.

Table 3-3. Examples\* of strategies to manage harmful energy flow.

Strategy	Examples
Eliminate energy concentrations	<ul style="list-style-type: none"> <li>· Control/limit floor loading</li> <li>· Disconnect/remove energy source from system</li> <li>· Remove combustibles from welding site</li> <li>· Change to nonflammable solvent</li> </ul>
Limit quantity and/or level of energy	<ul style="list-style-type: none"> <li>· Store heavy loads on ground floor</li> <li>· Lower dam height</li> <li>· Reduce system design voltage/operating pressure</li> <li>· Use small(er) electrical capacitors/pressure accumulators</li> <li>· Reduce/ control vehicle speed</li> <li>· Monitor/limit radiation exposure</li> <li>· Substitute less energetic chemicals</li> </ul>
Prevent release of energy	<ul style="list-style-type: none"> <li>· Heavy-wall pipe or vessels</li> <li>· Interlocks</li> <li>· Tagout – lockouts</li> <li>· Double-walled tankers</li> <li>· Wheel chocks</li> </ul>
Modify rate of release of energy	<ul style="list-style-type: none"> <li>· Flow restrictors in discharge lines</li> <li>· Resistors in discharge circuits</li> <li>· Fuses/circuit interrupters</li> </ul>
Separate energy from target in time and/or space	<ul style="list-style-type: none"> <li>· Evacuate explosive test areas</li> <li>· Impose explosives quantity-distance rules</li> <li>· Install traffic signals</li> <li>· Use yellow no-passing lines on highways</li> <li>· Control hazardous operations remotely</li> </ul>
Isolate by imposing a barrier	<ul style="list-style-type: none"> <li>· Guard rails</li> <li>· Toe boards</li> <li>· Hard hats</li> <li>· Face shields</li> <li>· Machine tool guards</li> <li>· Dikes</li> <li>· Grounded appliance frames/housing</li> <li>· Safety goggles</li> </ul>
Modify target contact surface or basic structure	<ul style="list-style-type: none"> <li>· Cushioned dashboard</li> <li>· Fluted stacks</li> <li>· Padded rocket motor test cell interior</li> <li>· Whipple plate meteorite shielding</li> <li>· Breakaway highway sign supports</li> <li>· Foamed runways</li> </ul>
Strengthen potential target	<ul style="list-style-type: none"> <li>· Select superior material</li> <li>· Substitute forged part for cast part</li> <li>· “Harden” control room bunker</li> <li>· Cross-brace transmission line tower</li> </ul>
Control improper energy input	<ul style="list-style-type: none"> <li>· Use coded, keyed electrical connectors</li> <li>· Use match-threaded piping connectors</li> <li>· Use back flow preventors</li> </ul>

\*Examples provided courtesy of Sverdrup Technology Inc., Tullahoma, Tennessee.

### 3.3.5 Advantages

The energy flow/barrier analysis provides a systematic thought process to identify hazards associated with energy sources and determines if current or planned barriers are adequate countermeasures to protect exposed targets.<sup>3,4</sup>

### 3.3.6 Limitations

The energy flow/barrier analysis possesses the following limitations.<sup>3,4</sup>

- (1) Even after a thorough analysis, all hazards might not be discovered. Like the PHA (sec. 3.2), an energy flow/barrier analysis fails to assess risks of combined hazards or coexisting system failure modes.
- (2) This tool also fails to identify certain classes of hazards, e.g., asphyxia in oxygen-deficient confined spaces.
- (3) Due to design and performance requirements, it is not always obvious that energy may be reduced or redirected. A reexamination of energy as heat, potential versus kinetic mechanical energy, electrical, chemical, etc. may aid this thought process.

### 3.3.7 Bibliography

Department of Energy, DOD 76–451: SSDC–29, “Barrier Analysis.”

Haddon, W., Jr., M.D.: “Energy Damage and the Ten Countermeasure Strategies.” *Human Factors Journal*, August 1973.

Johnson, W.G.: “MORT Safety Assurance Systems.” Marcel Dekker, Inc., 1980.

## **3.4 Failure Modes and Effects (and Criticality) Analysis**

### 3.4.1 Description

An FMEA, as described in reference 3.5, is a forward logic (bottom-up), tabular technique that explores the ways or modes in which each system element can fail and assesses the consequences of each of these failures. In its practical application, its use is often guided by top-down “screening” (as described in sec. 3.4.3) to establish the limit of analytical resolution. An FMECA also addresses the criticality or risk of individual failures. Countermeasures can be defined, for each failure mode, and consequent reductions in risk can be evaluated. FMEA and FMECA are useful tools for cost and benefit studies (sec. 2.2), to implement effective risk mitigation and countermeasure, and as precursors to a fault tree analysis (FTA) (sec. 3.5).

### 3.4.2 Application

An FMEA can be used to call attention to system vulnerability to failures of individual components. Single-point failures can be identified. This tool can be used to provide reassurance that the cause, effect, and associated risk (FMECA) of component failures have been appropriately addressed. These tools are applicable within systems or at the system-subsystem interfaces and can be applied at the system, subsystem, component, or part levels.

These failure mode analyses are typically performed during phase C. During this phase, these analyses can be done with or shortly after the PHA (sec. 3.2). The vulnerable points identified in the analyses can aid management in making decisions to allocate resources in order to reduce vulnerability.

### 3.4.3 Procedures

Procedures for preparing and performing FMECA's, as described in reference 3.5, are presented below. Procedures for preparing an FMEA are the same with steps 8 through 12 omitted.

Steps prior to performing the FMEA or FMECA:

- (1) Define the scope and boundaries of the system to be assessed. Gather pertinent information relating to the system, such as requirement specifications, descriptions, drawings, components and parts lists, etc. Establish the mission phases to be considered in the analysis.
- (2) Partition and categorize the system into advantageous and reasonable elements to be analyzed. These system elements include subsystems, assemblies, subassemblies, components, and piece parts.
- (3) Develop a numerical coding system that corresponds to the system breakdown (fig. 3-9).

Steps in performing the FMEA or FMECA (see flowchart presented in fig. 3-10):

- (4) Identify resources of value, such as personnel, facilities, equipment, productivity, mission or test objectives, environment, etc. to be protected. These resources are targets.
- (5) Identify and observe the levels of acceptable risk that have been predetermined and approved by management. These limits may be the risk matrix boundaries defined in a risk assessment matrix (sec. 3.2).
- (6) By answering the following questions posed in reference 3.5, the scope and resources required to perform a classical FMEA can be reduced, without loss of benefit:
  - a. Will a system failure render an unacceptable or unwanted loss?

If the answer is no, the analysis is complete. Document the results. (This has the additional benefit of providing visibility of nonvalue added systems, or it may serve to correct incomplete criteria being used for the FMEA.) If the answer is yes, ask the following question for each subsystem identified in step 2 above.

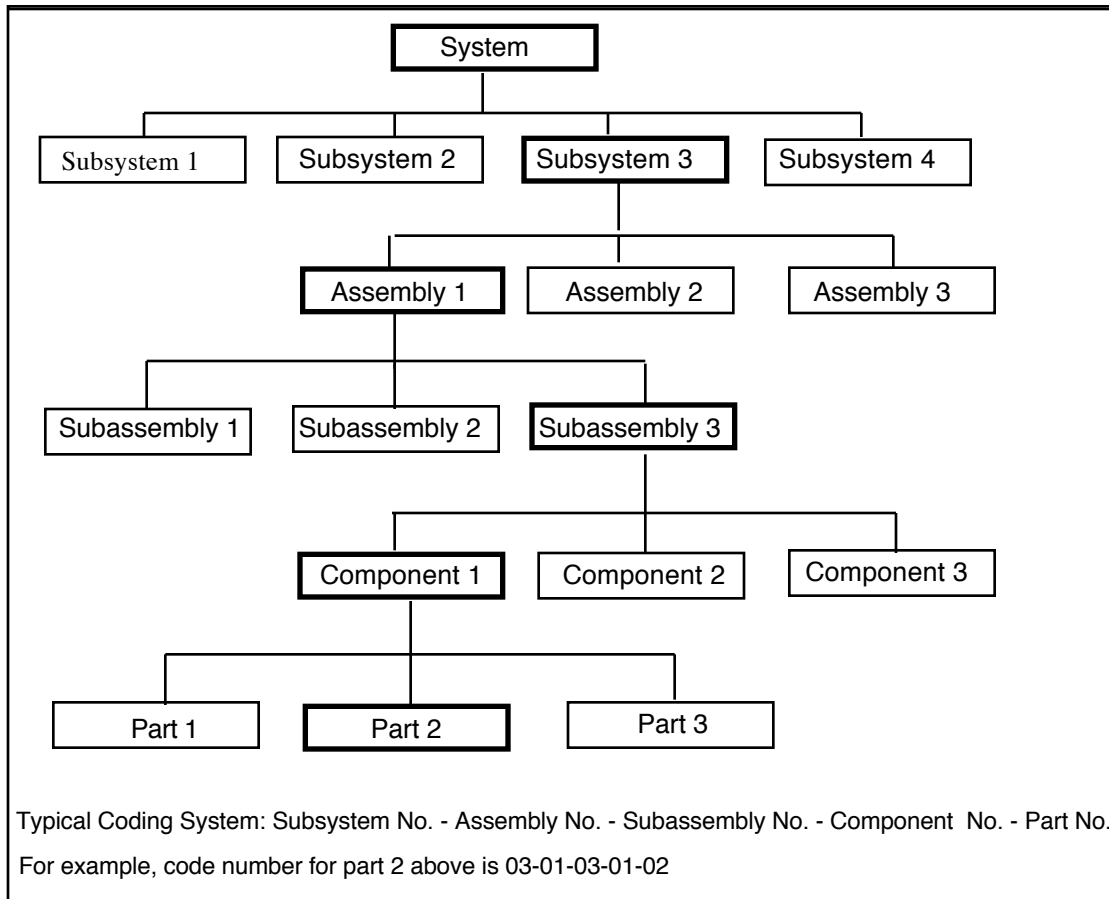

Figure 3-9. Example of system breakdown and numerical coding.<sup>3.5</sup>

- b. Will a subsystem failure render an unacceptable or unwanted loss?

If the answer for each subsystem is no, the analysis is complete. Document the results. If the answer is yes for any subsystem, ask the following question for each assembly of those subsystems identified in step 2 above.

- c. Will an assembly failure render an unacceptable or unwanted loss?

If the answer for each assembly is no, the analysis is complete. Document the results. If the answer is yes for any assembly, ask the following question for each component of those assemblies identified in step 2 above.

- d. Will a subassembly failure render an unacceptable or unwanted loss?

If the answer for each subassembly is no, the analysis is complete. Document the results. If the answer is yes for any subassembly, ask the following question for each component of those subassemblies identified in step 2 above:



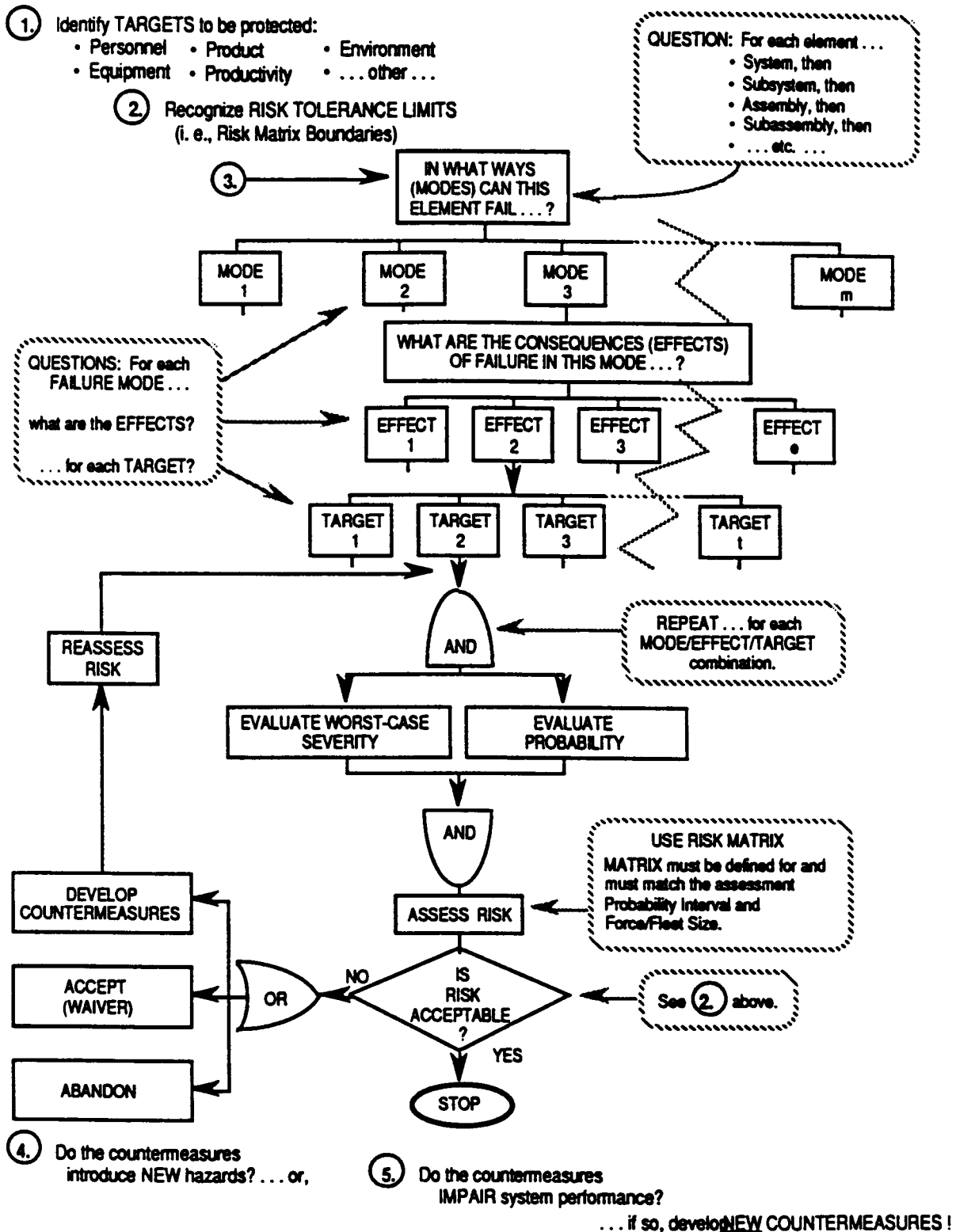

Figure 3-10. FMECA process flowchart.

e. Will a component failure render an unacceptable or unwanted loss?

If the answer for each component is no, the analysis is complete. Document the results. If the answer is yes for any component, ask the following question for each part of those components as identified in step 2 above.

f. Will a part failure render an unacceptable or unwanted loss?

- (7) For each element (system, subsystem, assembly, subassembly, component, or part) for which failure would render an unacceptable or unwanted loss, ask and answer the following questions:
  - a. What are the failure *modes* (ways to fail) for this element?
  - b. What are the *effects* (or consequences) of each failure mode on each target?
- (8) Assess worst-credible case (not the worst-conceivable case) severity and probability for each failure mode, effect, and target combination.
- (9) Assess risk of each failure mode using a risk assessment matrix (sec. 3.1). The matrix should be consistent with the established probability interval and force or fleet size for this assessment.
- (10) Categorize each identified risk as acceptable or unacceptable.
- (11) If the risk is unacceptable, then develop countermeasures to mitigate the risk.
- (12) Then reevaluate the risk with the new countermeasure installed.
- (13) If countermeasures are developed, determine if they introduce new hazards or intolerable or diminished system performance. If added hazards or degraded performance are unacceptable, develop new countermeasures and reevaluate the risk.
- (14) Document your completed analysis on an FMEA or FMECA worksheet. The contents and formats of these worksheets vary among organizations. Countermeasures may or may not be listed. Typically, the information found in an FMECA worksheet, according to reference 3.5, is presented in figure 3-11. A worksheet for an FMEA would be similar with the risk assessment information removed. A sample FMEA worksheet is attached in appendix F.



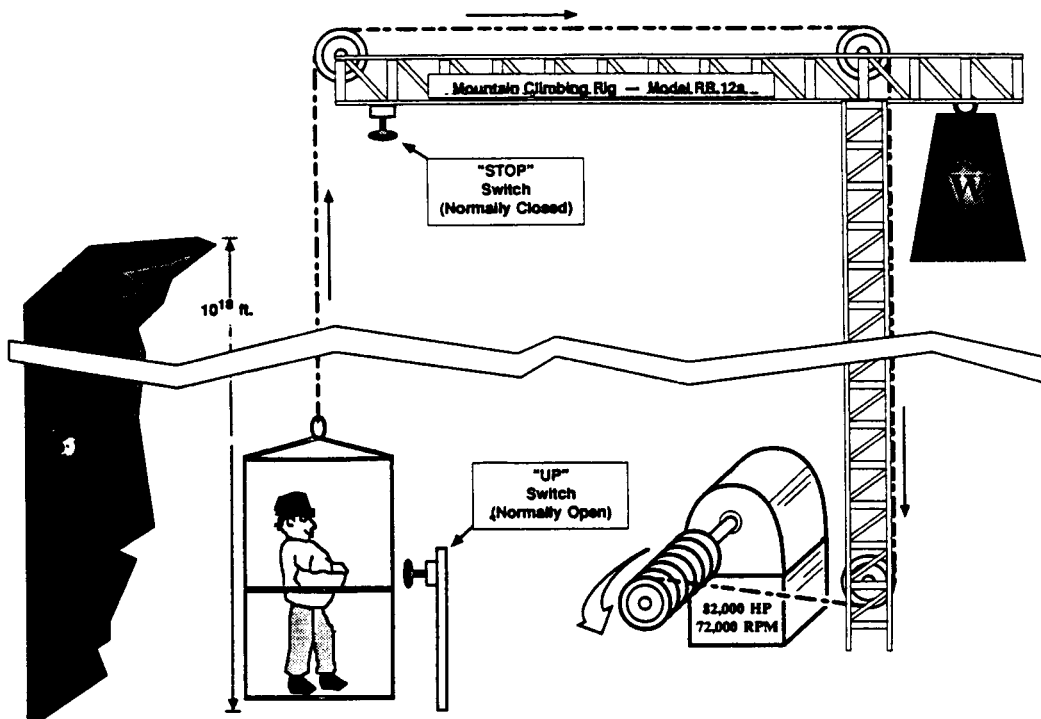

(a) System.

Subsystem	Assembly	Subassembly
Hoist (A)	Motor (A-01)	Windings (A-01-a) Inboard bearing (A-01-b) Outboard bearing (A-01-c) Rotor (A-01-d) Stator (A-01-e) Frame (A-01-f) Mounting plate (A-01-g) Wiring terminals (A-01-h)
	Drum (A-02)	
External power source (B)		
Cage (C)	Frame (C-01) Lifting Lug (C-02)	
Cabling (D)	Cable (D-01) Hook (D-02) Pulleys (D-03)	
Controls (E)	Switch (E-01)	START (E-01-a) FULL UP LIMIT (E-01-b) Wiring (E-01-c)

(b) System breakdown and coding.

Figure 3-12. Example of an FMECA—Continued

FMEA NO.: _____ PROJECT NO.: _____ _____ SUBSYSTEM NO.: <u>Controls</u> SYSTEM NO.: <u>Mountain Climbing</u> <u>Rig</u> _____ PROB. INTERVAL: <u>30 years</u> _____		<b>FAILURE MODES, EFFECTS, AND CRITICALITY ANALYSIS WORKSHEET</b>			SHEET ___ OF ___ DATE _____ PREPARED BY: _____ REVIEWED BY: _____ APPROVED BY: _____				
TARGET CODE: P – PERSONNEL / E – EQUIPMENT / T – DOWNTIME / R – PRODUCTS / D – DATA / V – ENVIRONMENT									
Id. No.	Item/ Functional Ident.	Failure Mode	Failure Cause	Failure Event	T a r g e t	Risk Assessment			Action Required/  Comments
						S e v	P r o b	R C i o s d k e	
E-01-a	Start switch	Switch fails closed.	Mechanical failure or corrosion.	Cage will not move.	P E T	IV IV IV	C C C	3 3 3	
E-01-b	Full up switch	Switch fails open.	Mechanical failure or corrosion.	Cage does not stop.	P	II	A	1	
E-02	Wiring	Cut, dis-connected.	Varmint invasion.	No response a switch. Start switch fails open. Stop switch fails closed. Cage stays in safe position.	P E T	IV IV IV	D D D	3 3 3	

(c) Worksheet.

Figure 3-12. Example of an FMECA—Continued.

### 3.4.5 Advantages

Performing FMEA's and FMECA's provide the following advantages:<sup>3.5</sup>

- (1) Provides a mechanism to be exhaustively thorough in identifying potential single-point failures and their consequences. An FMECA provides risk assessments of these failures.
- (2) Results can be used to optimize reliability, optimize designs, incorporate “fail safe” features into the system design, obtain satisfactory operation using equipment of “low reliability,” and guide in component and manufacturer selection.
- (3) Provide further analysis at the piece-part level for high-risk hazards identified in a PHA.

- (4) Identify hazards caused by failures to be added to the PHA that may have been previously overlooked in the PHA.
- (5) Provides a mechanism for more thorough analysis than an FTA, since every failure mode of each component of the system is assessed.<sup>3,6</sup>

#### 3.4.6 Limitations

The following limitations are imposed when performing FMEA's and FMECA's.

- (1) Costly in manhour resources, especially when performed at the parts-count level within large, complex systems.
- (2) Probabilities or the consequences of system failures induced by coexisting, multiple-element faults or failures within the system are not addressed or evaluated.
- (3) Although systematic, and guidelines/check sheets are available for assistance, no check methodology exists to evaluate the degree of completeness of the analysis.
- (4) This analysis is heavily dependent upon the ability and expertise of the analyst for finding all necessary modes.
- (5) Human error and hostile environments frequently are overlooked.
- (6) Failure probability data are often difficult to obtain for an FMECA.
- (7) If too much emphasis is placed on identifying and eliminating single-point failures, then focus on more severe system threats may be overlooked.
- (8) An FMECA can be a very thorough analysis suitable for prioritizing resources to higher risk areas if it can be performed early enough in the design phase. However, the level of design maturity required for an FMECA is not generally achieved until late in the design phase, often too late to guide this prioritization.

#### 3.4.7 Bibliography

Layton, D.: "System Safety – Including DOD Standards." Weber Systems Inc., Chester, OH, 1989.

Lees, F.P.: "Loss Prevention in the Process Industries." 2 vols. Butterworths, London, 1980.

MIL-STD-1629A, "Procedures for Performing a Failure Modes, Effects, and Criticality Analysis." November 1980.

Raheja, D.G.: "Assurance Technologies – Principles and Practices." McGraw-Hill, Inc., 1991.

Roberts, N.H., Vesely, W.E., Haasl, D.F., and Goldberg, F.F.: "Fault Tree Handbook." NUREG-0492. U.S. Government Printing Office, Washington, DC.

Roland, H.E., and Moriarty, B.: "System Safety Engineering and Management." John Wiley & Sons, 1982.

### 3.5 Reliability Block Diagram

#### 3.5.1 Description

A reliability block diagram (RBD) is a backwards (top-down) symbolic logic model generated in the success domain. The descriptions of RBD's contained herein was obtained from references 3.7 and 3.8. Each RBD has an input and an output and flows left to right from the input to the output. Blocks may depict the events or system element functions within a system. However, these blocks typically depict system element functions only. A system element can be a subsystem, subassembly, component, or part.

Simple RBD's are constructed of series, parallel, or combinations of series and parallel elements (table 3-4). Each block represents an event or system element function. These blocks are connected in series if all elements must operate successfully for the system to operate successfully. These blocks are connected in parallel if only one element needs to operate successfully for the system to operate successfully. A diagram may contain a combination of series and parallel branches. The system operates if an uninterrupted path exists between the input and output.

Table 3-4 . Simple RBD construction.

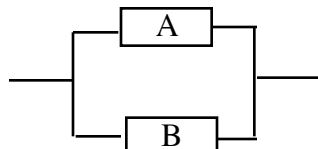
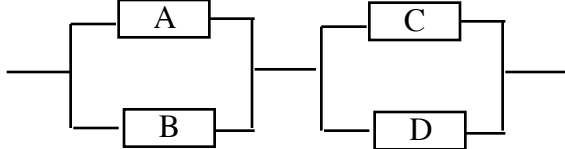
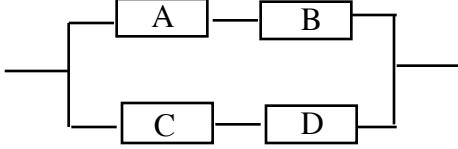
Type branch	Block diagram representation	System reliability #
Series		$R_S = R_A * R_B$
Parallel		$R_S = 1 - (1-R_A)(1-R_B)$
Series-parallel		$R_S = (1 - (1-R_A)(1-R_B)) * (1 - (1-R_C)(1-R_D))$
Parallel-series		$R_S = 1 - (1 - (R_A * R_B)) * (1 - (R_C * R_D))$

# Assumes all components function independently of each other.

RBD's illustrate system reliability. Reliability is the probability of successful operation during a defined time interval. Each element of a block diagram is assumed to function (operate successfully) or fail independently of each other element. The relationships between element reliability and system reliability for series and parallel systems are presented below, and their derivations are found in reference 3.8.

Series Systems:

$$R_S = \prod_i^n R_i = R_1 * R_2 * R_3 * \dots * R_n.$$

Parallel Systems:

$$R_S = 1 - \prod_i^n (1 - R_i) = [1 - (1 - R_1) * (1 - R_2) * (1 - R_3) * \dots * (1 - R_n)]$$

where

$R_S$  = system reliability,

$R_i$  = system element reliability, and

$n$  = number of system elements (which are assumed to function independently).

Not all systems can be modeled with simple RBD's. Some complex systems cannot be modeled with true series and parallel branches. These systems must be modeled with a complex RBD. Such an RBD is presented in figure 3-13. Notice in this example, if element E fails, then paths B, E, G and B, E, H are not success paths, thus this is not a true series or parallel arrangement.

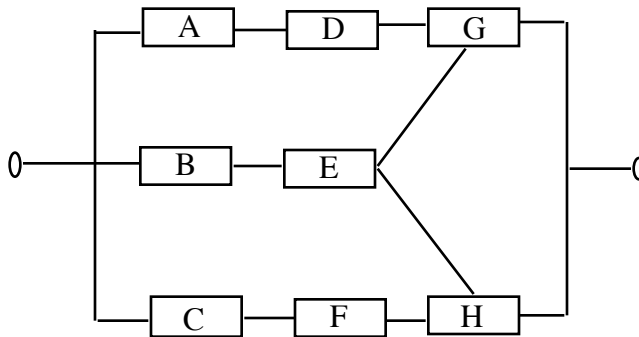

Figure 3-13. Typical complex RBD.



### 3.5.2 Application

An RBD allows evaluation of various potential design configurations.<sup>3.8</sup> Required subsystem and element reliability levels to achieve the desired system reliability can be determined. Typically, these functions are performed during phase C. An RBD may also be used to identify elements and logic as a precursor to performing an FTA (sec. 3.6).

### 3.5.3 Procedures

The procedures (adapted from reference 3.8) to generate a simple RBD are presented below:

- (1) Divide a system into its elements. A functional diagram of the system is helpful.
- (2) Construct a block diagram using the convention illustrated in table 3-4.
- (3) Calculate system reliability band,  $R_{SL}$  (low) to  $R_{SH}$  (high), from each individual element's reliability band,  $R_{iL}$  (low) to  $R_{iH}$  (high), in the following manner:
  - a. For series systems with  $n$  elements that are to function independently,

$$R_{SL} = \prod_i^n (R_{iL}) = R_{1L} * R_{2L} * R_{3L} * \cdots * R_{nL}$$

$$R_{SH} = \prod_i^n (R_{iH}) = R_{1H} * R_{2H} * R_{3H} * \cdots * R_{nH}.$$

- b. For parallel systems with  $n$  elements that are to function independently,

$$R_{SL} = 1 - \prod_i^n (1 - R_{pL}) = [1 - (1 - R_{1L}) * (1 - R_{2L}) * (1 - R_{3L}) * \cdots * (1 - R_{nL})]$$

$$R_{SH} = 1 - \prod_i^n (1 - R_{pH}) = [1 - (1 - R_{1H}) * (1 - R_{2H}) * (1 - R_{3H}) * \cdots * (1 - R_{nH})].$$

- c. For series-parallel systems, first determine the reliability for each parallel branch using the equations in step 3b. Then treat each parallel branch as an element in a series branch and determine the system reliability by using the equations in step 3a.
    - d. For parallel-series systems, first determine the reliability for each series branch using the equations in step 3a. Then treat each series branch as an element in a parallel branch and determine the system reliability by using the equations in step 3b.

- e. For systems that are composed of the four above arrangements, determine the reliability for the simplest branches. Then, treat these as branches within the remaining block diagram, and determine the reliability for the new simplest branches. Continue this process until one of the above four basic arrangements remains, then determine the system reliability.

### 3.5.4 Example

A system has two subsystems designated 1 and 2. Subsystem 2 is designed to be a backup for subsystem 1. Subsystem 1 has three components and at least one of the three must function successfully for the subsystem to operate. Subsystem 2 has three components that all need to function successfully for the subsystem to operate. The estimated reliability band for each individual component over the system's estimated 10-yr life interval is presented below:

Subsystem	Component	Reliability Bands	
		Low	High
1	A	0.70	0.72
1	B	0.80	0.84
1	C	0.60	0.62
2	D	0.98	0.99
2	E	0.96	0.97
2	F	0.98	0.99

An RBD for the system is presented in figure 3-14. Note that the components for subsystem 1 are in a parallel branch with the components of subsystem 2. Also, note that the components for subsystem 1 form a series branch and the components for subsystem 2 form a parallel branch.

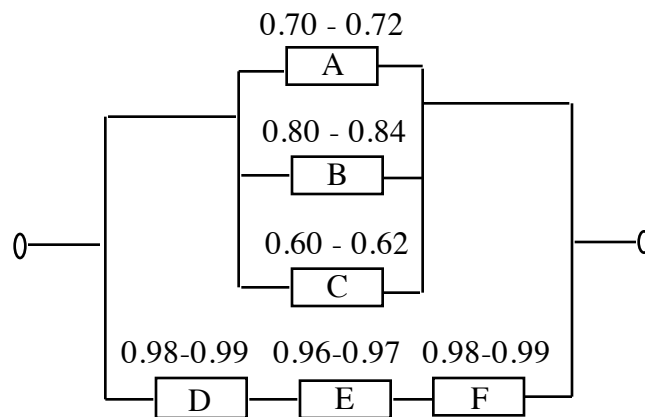

Figure 3-14. Example RBD.

Calculations for subsystem and system reliabilities are presented below:

$$\text{Subsystem 1: } R_{1L} = 1 - (1-0.70)(1-0.80)(1-0.60) = 0.976 \quad (\text{low band value})$$

$$R_{1H} = 1 - (1-0.72)(1-0.84)(1-0.62) = 0.983 \quad (\text{high band value})$$

$$\text{Subsystem 2: } R_{2L} = (0.98)(0.96)(0.98) = 0.922 \quad (\text{low band value})$$

$$R_{2H} = (0.99)(0.97)(0.99) = 0.951 \quad (\text{high band value})$$

$$\text{System: } R_{SL} = 1 - (1-0.976)(1-0.922) = 0.998 \quad (\text{low band value})$$

$$R_{SH} = 1 - (1-0.983)(1-0.951) = 0.999 \quad (\text{high band value})$$

Therefore, the reliability band for the system is 0.998 to 0.999.

### 3.5.5 Advantages

An RBD provides the following advantages:

- (1) Allows early assessment of design concepts when design changes can be readily and economically incorporated.<sup>3,8</sup>
- (2) Tends to be easier for an analyst to visualize than other logic models, such as a fault tree.<sup>3,7</sup>
- (3) Blocks representing elements in an RBD can be arranged in a manner that represent how these elements function in the system.<sup>3,7</sup>
- (4) Since RBD's are easy to visualize, they can be generated prior to performing an FTA and transformed into a fault tree by the method discussed in section 3.9.

### 3.5.6 Limitations

An RBD possesses the following limitations:

- (1) Systems must be broken down into elements where reliability estimates can be obtained. Such a breakdown for a large system can be a significant effort.<sup>3,8</sup>
- (2) System element reliability estimates might not be readily available for all elements. Some reliability estimates may be very subjective, difficult to validate, and not be accepted by others in the decision making process. If the element reliability values have different confidence bands, this can lead to significant problems.
- (3) Not all systems can be modeled with combinations of series, parallel, series-parallel, or parallel-series branches. These complex systems can be modeled with a complex RBD. However, determining system reliability for such a system is more difficult than for a simple RBD.<sup>3,7,3,8</sup>

### 3.5.7 Bibliography

Pages, A. and Godran, M.: "System Preliminary Evaluation & Prediction in Engineering." Springer-Verb, 1986.

## 3.6 Fault Tree Analysis

### 3.6.1 Description

A fault tree analysis (FTA), as described in reference 3.9, is a top-down symbolic logic model generated in the failure domain. This model traces the failure pathways from a predetermined, undesirable condition or event, called the TOP event, of a system to the failures or faults (fault tree initiators) that could act as causal agents. Previous identification of the undesirable event also includes a recognition of its severity. An FTA can be carried out either quantitatively or subjectively.

The FTA includes generating a fault tree (symbolic logic model), entering failure probabilities for each fault tree initiator, propagating failure probabilities to determining the TOP event failure probability, and determining cut sets and path sets. A cut set is any group of initiators that will, if they all occur, cause the TOP event to occur. A minimal cut is a least group of initiators that will, if they all occur, cause the TOP event to occur. A path set is a group of fault tree initiators that, if none of them occurs, will guarantee the TOP event cannot occur.

The probability of failure for a given event is defined as the number of failures per number of attempts. This can be expressed as:

$$P_F = F/(S+F) , \text{ where } F = \text{number of failures and } S = \text{number of successes.}$$

Since reliability for a given event is defined as the number of successes per number of attempts, then the relationship between the probability of failure and reliability can be expressed as follows:

$$R = S/(S+F),$$

therefore

$$R + P_F = S/(S+F) + F/(S+F) = 1$$

and

$$P_F = 1-R.$$

### 3.6.2 Application

FTA's are particularly useful for high energy systems (i.e., potentially high severity events), to ensure that an ensemble of countermeasures adequately suppresses the probability of mishaps. An FTA is a powerful diagnostic tool for analysis of complex systems and is used as an aid for design improvement.

This type of analysis is sometimes useful in mishap investigations to determine cause or to rank potential causes. Action items resulting from the investigation may be numerically coded to the fault tree elements they address, and resources prioritized by the perceived highest probability elements.

FTA's are applicable both to hardware and nonhardware systems and allow probabilistic assessment of system risk as well as prioritization of the effort based upon root cause evaluation. The subjective nature of risk assessment is relegated to the lowest level (root causes of effects) in this study rather than at the top level. Sensitivity studies can be performed allowing assessment of the sensitivity of the TOP event to basic initiator probabilities.

FTA's are typically performed in phase C but may also be performed in phase D. FTA's can be used to identify cut sets and initiators with relatively high failure probabilities. Therefore, deployment of resources to mitigate risk of high-risk TOP events can be optimized.

### 3.6.3 Procedures

The procedures, as described in reference 3.9, for performing an FTA are presented below. These procedures are divided into the four phases: (1) fault tree generation, (2) probability determination, (3) identifying and assessing cut sets, and (4) identifying path sets. The analyst does not have to perform all four phases, but can progress through the phases until the specific analysis objectives are met. The benefits for each of the four phases are summarized in table 3-5.

Table 3-5. FTA procedures.

Section	Procedures	Benefits
3.6.3.1	Fault tree generation	All basic events (initiators), intermediate events, and the TOP event are identified. A symbolic logic model illustrating fault propagation to the TOP event is produced.
3.6.3.2	Probability determination	Probabilities are identified for each initiator and propagated to intermediate events and the TOP event.
3.6.3.3	Identifying and assessing cut sets	All cut sets and minimal cuts sets are determined. A cut set is any group of initiators that will, if they all occur, cause the TOP event to occur. A minimal cut set is a <u>least</u> group of initiators that, if they all occur, will cause the TOP event to occur. Analysis of a cut set can help evaluate the probability of the TOP event, identify qualitative common cause vulnerability, and assess quantitative common cause probability. Cut sets also enable analyzing structural, quantitative, and item significance of the tree.
3.6.3.4	Identifying path sets	All path sets are determined. A path set is a group of fault tree initiators that, if none of them occurs, will guarantee the TOP event cannot occur.

### 3.6.3.1 Fault Tree Generation

Fault trees are constructed with various event and gate logic symbols, defined in table 3-6. Although many event and gate symbols exist, most fault trees can be constructed with the following four symbols: (1) TOP or Intermediate event, (2) inclusive OR gate, (3) AND gate, and (4) basic event. The procedures, as described in reference 3.9, to construct a fault tree are illustrated in figure 3-15.

A frequent error in fault tree construction is neglecting to identify common causes. A common cause is a condition, event, or phenomenon that will simultaneously induce two or more elements of the fault tree to occur. A method for detecting common causes is described in section 3.6.3.3, step 8. Sections 3.6.3.2 through 3.6.4.3 are included for completeness and to provide insight as to the mathematics that takes place in the commercially available fault tree programs. All large trees are typically analyzed using these programs; for small trees hand analysis may be practical.

### 3.6.3.2 Probability Determination

If a fault tree is to be used as a quantitative tool, the probability of failure must be determined for each basic event or initiator. Sources for these failure probabilities may be found from manufacturer's data, industry consensus standards, MIL-standards, historical evidence (of the same or similar systems), simulation or testing, Delphi estimates, and the log average method. A source for human error probabilities is found in reference 3.10. The Delphi technique (sec. 7.9) derives estimates from the consensus of experts. The log average method is useful when the failure probability cannot be estimated but credible upper and lower boundaries can be estimated. This technique is described in reference 3.11 and is illustrated in figure 3-16.

Failure probabilities can also be determined from a PDA as discussed in section 3.14.3, step 6.









Probabilities must be used with caution to avoid the loss of credibility of the analysis. In many cases it is best to stay with comparative probabilities rather than the "absolute" values. Normalizing data to a standard, explicitly declared meaningless value is a useful technique here. Also, confidence or error bands, on each cited probability number, are required to determine the significance of any quantitatively driven conclusion.

Once probabilities are estimated for all basic events or initiators, they are propagated through logic gates to the intermediate events and finally the TOP event. The probability of failure of independent inputs through an AND gate is the intersection of their respective individual probabilities. The probability of failure of independent events through an OR (inclusive) gate is the union of their respective individual probabilities. Propagation of confidence and error bands is performed simply by propagation of minimum and maximum values within the tree.

The relationship between reliability and failure probability propagation of two and three inputs through OR (inclusive) and AND gates is illustrated in figure 3-17. Propagation of failure probabilities for two independent inputs through an AND and OR (inclusive) is conceptually illustrated in figure 3-18. As shown in figures 3-17, the propagation solution through an OR gate is simplified by the rare event approximation assumption. The exact solution for OR gate propagation is presented in figure 3-19. However, the use of this exact solution is seldom warranted.

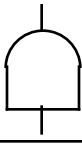
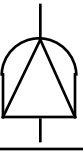
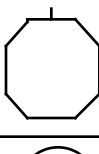
The propagation equations for the logic gates, including the gates infrequently used, are presented in table 3-7.

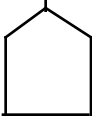
Table 3-6. Fault tree construction symbols.

Symbol	Name	Description
	Event (TOP or intermediate)*	<u>TOP Event</u> – This is the conceivable, undesired event to which failure paths of lower level events lead. <u>Intermediate Event</u> – This event describes a system condition produced by preceding events.
	Inclusive OR gate*	An output occurs if one or more inputs exist. Any single input is necessary and sufficient to cause the output event to single occur.
	Exclusive OR gate	An output occurs if one, but only one input exists. Any single input is necessary and sufficient to cause the output event to occur.
	Mutually exclusive OR gate	An output occurs if one or more inputs exist. However, all other inputs are then precluded. Any single input is necessary and sufficient to cause the output event to occur.
	AND gate*	An output occurs if all inputs exist. All inputs are necessary and sufficient to cause the output event to occur.
	Priority AND gate	An output occurs if all inputs exist and occur in a predetermined sequence. All inputs are necessary and sufficient to cause the output event to occur.
	INHIBIT gate	An output occurs if a single input event occurs in presence of an enabling condition.
	Basic event*	An initiating fault or failure that is not developed further. These events determine the resolution limit of the analysis. They are also called leaves or initiators.
	External event	An event that under normal conditions is expected to occur.
	Undeveloped event	An event not further developed due to a lack of need, resources, or information.
	Conditioning Event	These symbols are used to affix conditions, restraints, or restrictions to other events.

\*Most fault trees can be constructed with these four logic symbols.

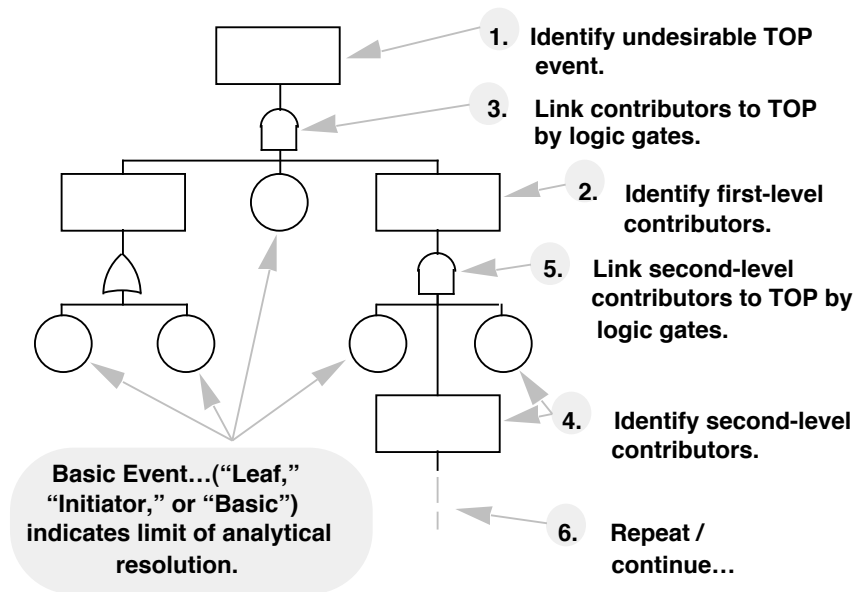
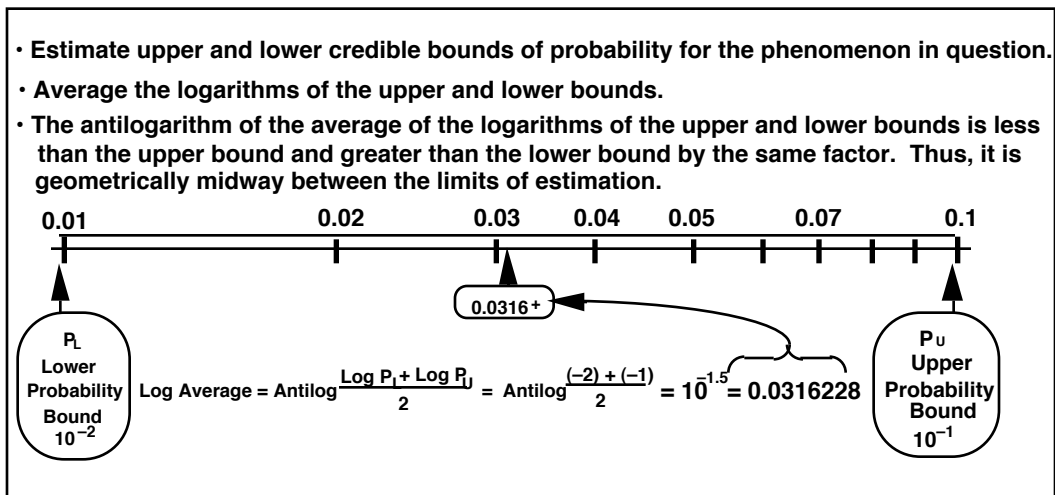

Figure 3-15. Fault tree construction process.



Note that, for the example shown, the arithmetic average would be...

$$\frac{0.01 + 0.1}{2} = 0.055$$

i.e., 5.5 times the lower bound and 0.55 times the upper bound.

Figure 3-16. Log average method of probability estimation.



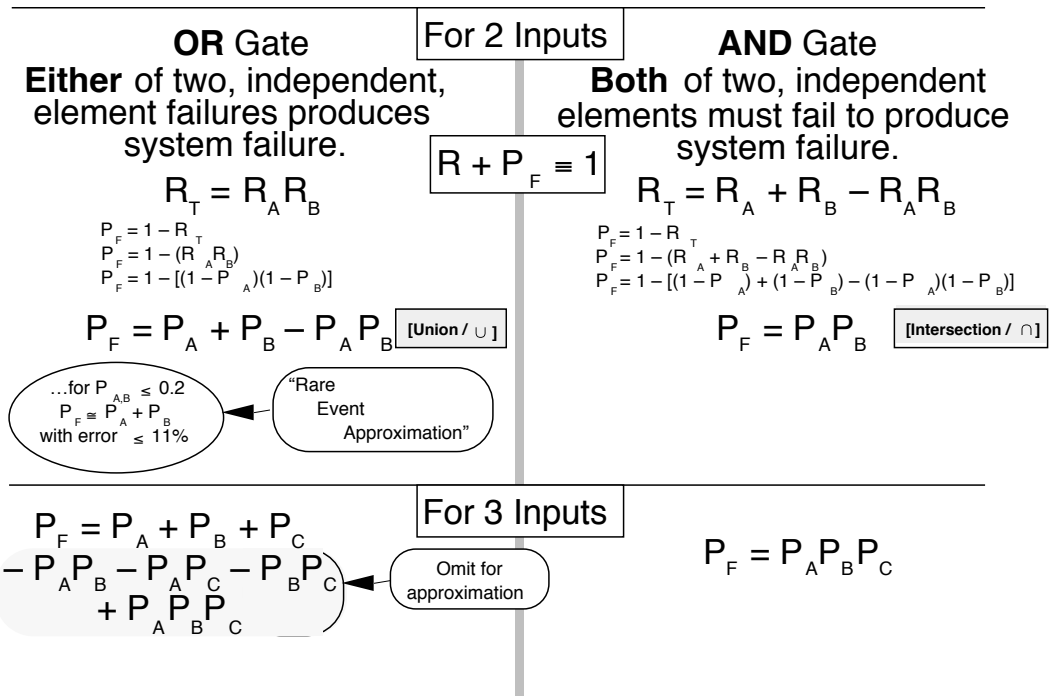

Figure 3-17. Relationship between reliability and failure probability propagation.

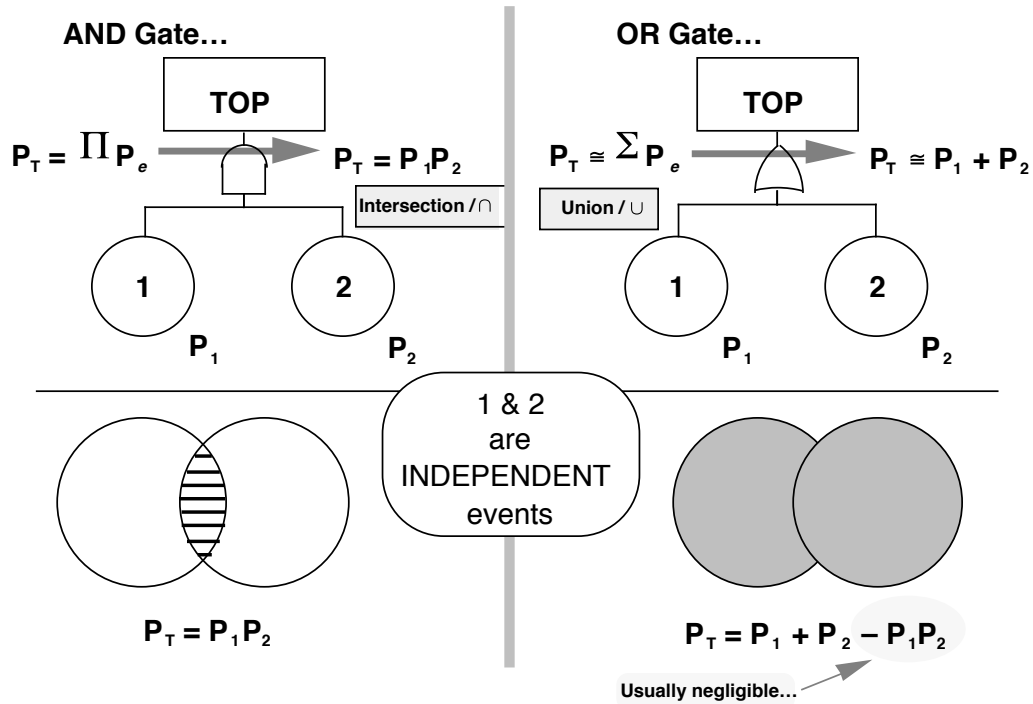
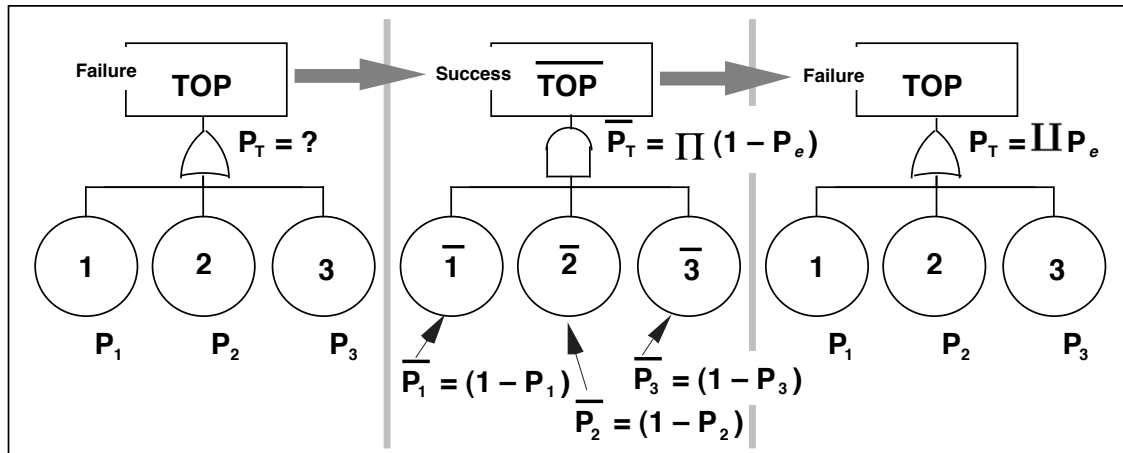

Figure 3-18. Failure probability propagation through OR and AND gates.



The pi operator ( $\prod$ ) is the co-function of pi ( $\sum$ ). It provides an exact solution for propagating probabilities through the OR gate. Its use is rarely justifiable.

$$P_T = \sum P_e = 1 - \prod (1 - P_e)$$

$$P_T = 1 - [(1 - P_1)(1 - P_2)(1 - P_3) \dots (1 - P_n)]$$

Figure 3-19. Exact solution of OR gate failure probability propagation.





### 3.6.3.3 Identifying and Assessing Cut Sets

A cut set is any group of initiators that will produce the TOP event, if all the initiators in the group occur. A minimal cut set is the smallest number (in terms of elements, not probability) of initiators that will produce the TOP event, if all the initiators in the group occur. One method of determining and analyzing cut sets is presented below. These procedures for determining cut sets are described in reference 3.9 and are based on the MOCUS computer algorithm attributed to J.B. Fussell. Analysis of a cut set can help evaluate the probability of the TOP event, identify common cause vulnerability, and assess common cause probability. Cut sets also enable analyzing structural, quantitative, and item significance of the tree.

#### Determining Cut Sets:

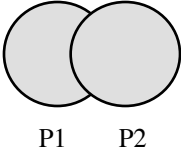
- (1) Consider only the basic events or initiators (discarding intermediate events and the TOP event).
- (2) Assign a unique letter to each gate and a unique number to each initiator, starting from the top of the tree.
- (3) From the top of the tree downwards, create a matrix using the letters and numbers. The letter for the gate directly beneath the TOP event will be the first entry in the matrix. Proceed through the matrix construction by (1) substituting the letters for each AND gate with letters for the gates and numbers of the initiators that input into that gate (arrange these letters and numbers horizontally in the matrix rows), and (2) substituting the letters for each OR gate with letters for the gates and numbers of the initiators that input into that gate (arrange these letters and numbers vertically in the matrix columns).

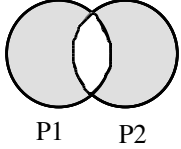
Table 3-7. Probability propagation expressions for logic gates.

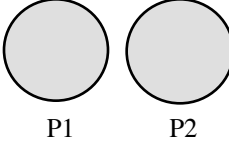
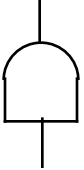
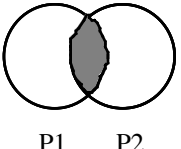
Symbol	Name	Venn Diagram	Propagation Expressions
	Inclusive OR gate <sup>‡</sup>		$P_T = P_1 + P_2 - (P_1 * P_2)$ $P_T = P_1 + P_2^{\#}$
	Exclusive OR gate		$P_T = P_1 + P_2 - 2(P_1 * P_2)$ $P_T = P_1 + P_2^{\#}$
	Mutually exclusive OR gate		$P_T = P_1 + P_2$
	AND gate <sup>‡</sup> and (priority AND gate)		$P_T = P_1 * P_2$

<sup>‡</sup>Most fault trees can be constructed with these two logic gates.

<sup>#</sup>Simplified expression for rare event approximation assumption.

- (4) When all the gate's letters have been replaced, a final matrix is produced with only numbers of initiators. Each row of this matrix represents a Boolean-indicated cut set.
- (5) Visually inspect the final matrix and eliminate any row that contains all elements of a lesser row. Next, through visual inspection, eliminate redundant elements within rows and rows that repeat other rows. The remaining rows define the minimal cut sets of the fault tree.

#### Assessing Cut Sets:

- (6) Since a cut set is any group of initiators that will produce the TOP event, if all the initiators in the group occur, the cut set probability,  $P_K$  (the probability that the cut set will induce the TOP event) is mathematically the same as the propagation through an AND gate, expressed as:

$$P_K = P_1 * P_2 * P_3 * P_4 \cdots * P_n.$$

- (7) Determine common cause vulnerability by uniquely assigning letter subscripts for common causes to each numbered initiator (such as  $m$  for moisture,  $h$  for human operator,  $q$  for heat,  $v$  for vibration, etc.). Note that some initiators may have more than one subscript, while others will have none. Check to see if any minimal cut sets have elements with identical subscripts. If that is the case, then the TOP event is vulnerable to the common cause the subscript represents. This indicates that the probability number, calculated as above, may be significantly in error, since the same event (the so-called common cause) could act to precipitate each event, i.e., they no longer represent statistically independent events.
- (8) Analyze the probability of each common cause at its individual probability level of both occurring, and inducing all terms within the affected cut set.
- (9) Assess the structural significance of the cut sets to provide qualitative ranking of contributions to system failure. Assuming all other things are equal then:
  - a. A cut set with many elements indicates low vulnerability.
  - b. A cut set with few elements indicates high vulnerability.
  - c. Numerous cut sets indicates high vulnerability.
  - d. A cut set with a single initiator, called a singleton, indicates a potential single-point failure.
- (10) Assess the quantitative Importance,  $I_K$ , of each cut set,  $K$ . That is, determine the numerical probability that this cut set induced the TOP event, assuming it has occurred.

$$I_K = P_K/P_T$$

where

$P_K$  = the probability that the cut set will occur (see step 6 above), and

$P_T$  = the probability of the TOP event occurring.

- (11) Assess the quantitative importance,  $I_e$ , of each individual initiator,  $e$ . That is, determine the numerical probability that initiator  $e$  contributed to the TOP event, if it has occurred:

$$I_e = \sum_e^{N_e} I_{K_e}$$

where

$N_e$  = number of minimal cut sets containing initiator  $e$ , and

$I_{K_e}$  = importance of the minimal cut sets containing initiator  $e$ .

#### 3.6.3.4 Identifying Path Sets

A path set is a group of fault tree initiators that, if none of them occurs, ensures the TOP event cannot occur. Path sets can be used to transform a fault tree into a reliability diagram (sec. 3.9). The procedures to determine path sets are as follows:

- (1) Exchange all AND gates for OR gates and all OR gates for AND gates on the fault tree.

- (2) Construct a matrix in the same manner as for cut sets (sec. 3.6.3.3, steps 1–5). Each row of the final matrix defines a path set of the original fault tree.

### 3.6.4 Examples

#### 3.6.4.1 Fault Tree Construction and Probability Propagation

An example of a fault tree with probabilities propagated to the TOP event is presented in figure 3-20. In this example the TOP event is the “artificial wakeup fails.” The system being examined consists of alarm clocks used to awaken someone. In this example for brevity, only a nominal probability value for each fault tree initiator is propagated through the fault tree to the TOP event. However, for a thorough analysis, both low and high probability values that define a probability band for each initiator could be propagated through the fault tree to determine a probability band for the TOP event.

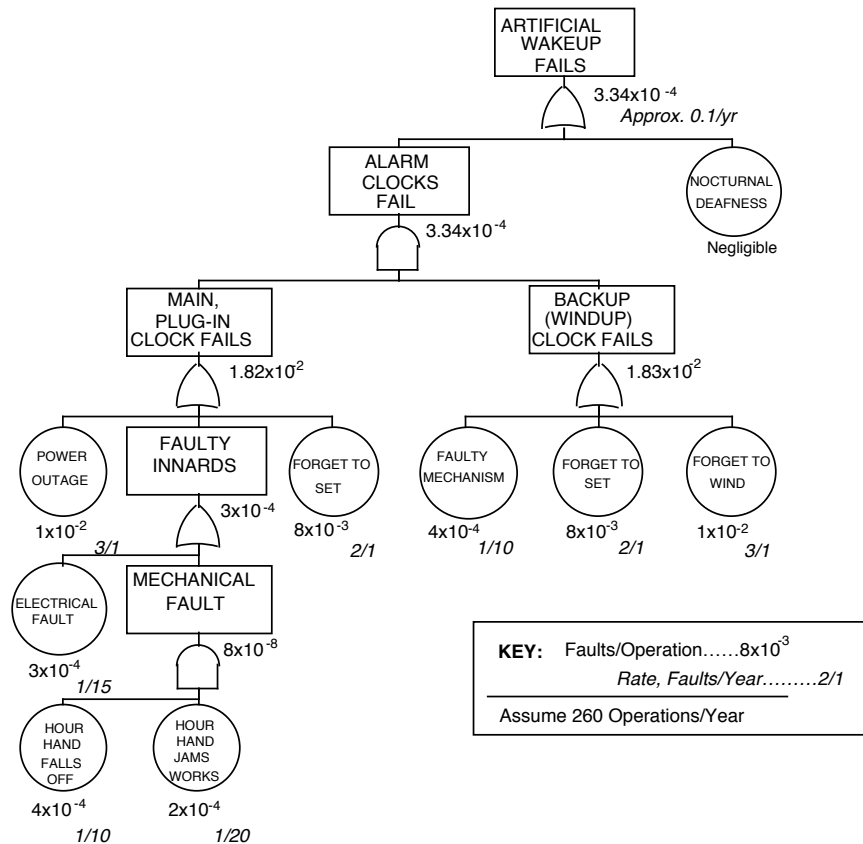

Figure 3-20. Example fault tree.

### 3.6.4.2 Cut Sets

An example of how to determine Boolean-indicated minimal cut sets for a fault tree is presented in figure 3-21.

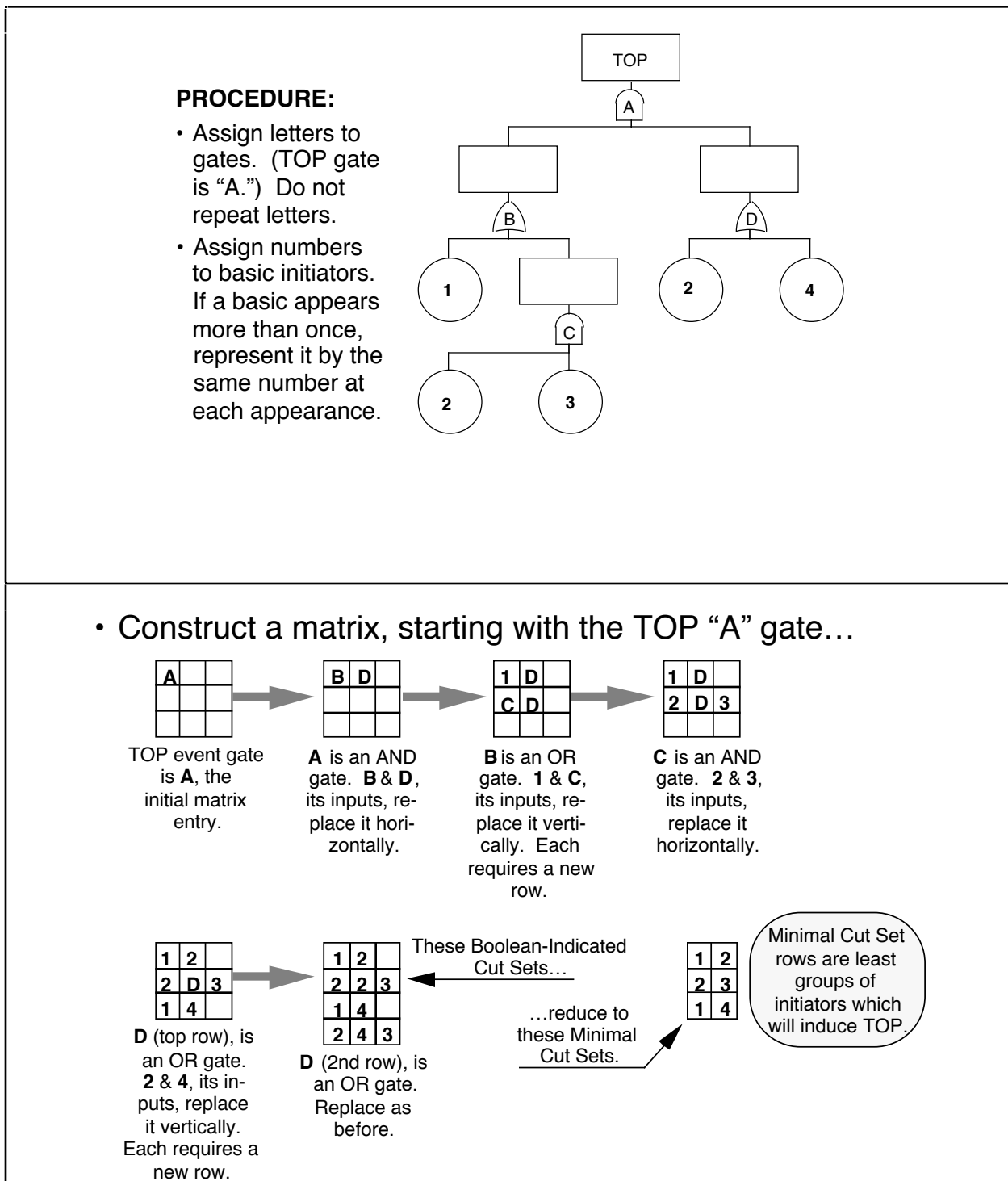

Figure 3-21. Example of determining cut sets.

### 3.6.4.3 Path Sets

An example of how to determine path sets for a fault tree is presented in figure 3-22.

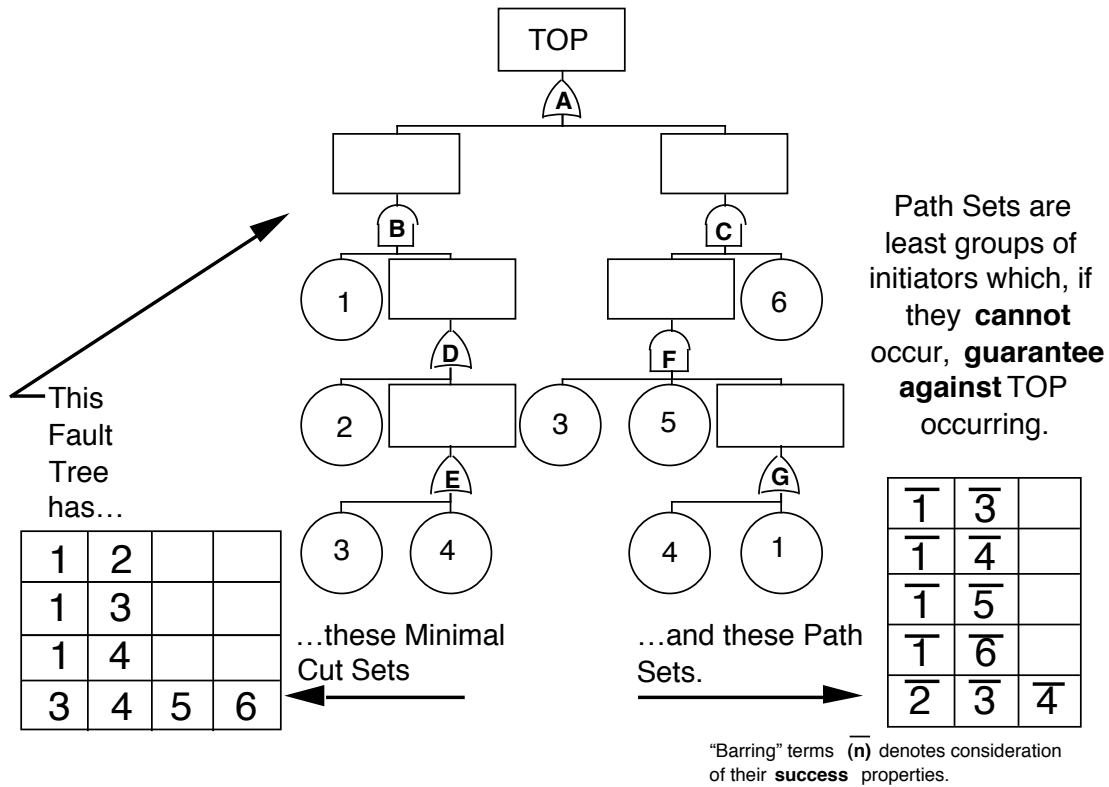

Figure 3-22. Example of determining path sets.

### 3.6.5 Advantages

An FTA provides the following advantages:<sup>3,9</sup>

- (1) Enables assessment of probabilities of combined faults/failures within a complex system.
- (2) Single-point and common cause failures can be identified and assessed.
- (3) System vulnerability and low-payoff countermeasures are identified, thereby guiding deployment of resources for improved control of risk.
- (4) This tool can be used to reconfigure a system to reduce vulnerability.
- (5) Path sets can be used in trade studies to compare reduced failure probabilities with increases in cost to implement countermeasures.

### 3.6.6 Limitations

A FTA possesses the following limitations:

- (1) Address only one undesirable condition or event that must be foreseen by the analyst. Thus, several or many FTA's may be needed for a particular system.
- (2) Fault trees used for probabilistic assessment of large systems may not fit or run on conventional PC-based software.
- (3) The generation of an accurate probabilistic assessment may require significant time and resources. Caution must be taken not to "over work" determining probabilities or evaluating the system, i.e., limit the size of the tree.
- (4) A fault tree is not accurate unless all significant contributors of faults or failures are anticipated.
- (5) Events or conditions under the same logic gate must be independent of each other.
- (6) A fault tree is flawed if common causes have not been identified.
- (7) Events or conditions at any level of the tree must be independent and immediate contributors to the next level event or condition.
- (8) The failure rate of each initiator must be constant and predictable. Specific (noncomparative) estimates of failure probabilities are typically difficult to find, to achieve agreement on, and to successfully use to drive conclusions. Comparative analyses are typically as valuable with better receptions from the program and design teams.

### 3.6.7 Bibliography

- Crosetti, P.A.: "Reliability and Faulttree Analysis Guide." Department of Energy No. DOE 76-45/22, 1982.
- Dillon, B.S., and Singh, C.: "Engineering Reliability – New Techniques and Applications." John Wiley & Sons, 1981.
- Fussell, J.B., and Burdick, G.R.: "Nuclear Systems Reliability Engineering and Risk Assessment." Society for Industrial and Applied Mathematics, 1977.
- Hammer, W: "Handbook of System and Product Safety." Prentice Hall, 1972.
- Henley, E.J., and Kumamoto, H.: "Probabilistic Risk Assessment." The Institute of Electrical and Electronic Engineers, Inc., New York, 1991.
- Malsaky, S.W.: "System Safety: Technology and Application." Garland Press, 1983.
- Roberts, N.H., Vesely, W.E., Haasl, D.F., and Goldberg, F.F.: "Fault Tree Handbook." NUREG-0492, U.S. Government Printing Office, Washington, DC.
- Roland, H.E., and Moriarty, B.: "System Safety Engineering and Management." John Wiley & Sons, 1982.



William S.G., Riley, J., and Koren, J.M.: “A New Approach to the Analysis of Reliability Block Diagrams.” Proceedings from Annual Reliability and Maintainability Symposium, SAIC, Los Altos, New Mexico, 1990.

Wynholds, W., Potterfield, R., and Bass, L.: “Fault Tree Graphics – Application to System Safety.” Proceedings of the Second International System Safety Conference, 1975.

### 3.7 Success Tree Analysis

#### 3.7.1 Description

A success tree analysis (STA) is a backwards (top-down) symbolic logic model generated in the success domain. This model traces the success pathways from a predetermined, desirable condition or event (TOP event) of a system to the successes (success tree initiators) that could act as causal agents. An STA is the compliment of an FTA (sec. 3.6) which is generated in the failure domain with failure pathways from undesirable events.

The STA includes generating a success tree (symbolic logic model), determining success probabilities for each tree initiator, propagating each initiator probability to determining the TOP event probability and determining cut sets and path sets. In the success domain, a cut set is any group of initiators that will, if they all occur, prevent the TOP event from occurring. A minimal cut set is a least group of initiators that will, if they all occur, prevent the TOP event from occurring. A path set is a group of success tree initiators that, if all of them occur, will guarantee the TOP event occurs.

The probability of success for a given event is defined as the number of successes per number of attempts. This can be expressed as:

$$P_S = S/(S+F) , \text{ where } S = \text{number of successes and } F = \text{number of failures.}$$

Since reliability for a given event is also defined as the number of successes per number of attempts, then

$$R = P_S.$$

#### 3.7.2 Application

Particularly useful for high energy systems (i.e., potentially high severity events), to ensure that an ensemble of countermeasures adequately leads to a successful top event. This technique is a powerful diagnostic tool for analysis of complex systems and is used as an aid for design improvement and is applicable both to hardware and nonhardware systems. This technique also allows probabilistic assessment of causal benefits as well as prioritization of effort based upon root cause evaluation. The subjective nature of the probability assessment is relegated to the lowest level (root causes of effects) in this study rather than at top level. Sensitivity studies can be performed allowing assessment of the sensitivity of study results to subjective numbers.

The STA is typically applied in phase C but may also be applied in phase D. A success tree can be used to verify the logic of a fault tree. Since a success tree is the logic compliment of a fault tree, if a success tree is generated from a fault tree, the logic of the success tree needs to be valid if the logic of a fault tree is to be valid.

### 3.7.3 Procedures

Success trees, like fault trees, are constructed with various event and gate logic symbols. These symbols are defined in table 3-6. Although many event and gate symbols exist, most success trees can be constructed with the following four symbols: (1) TOP or intermediate event, (2) inclusive OR gate, (3) AND gate, and (4) basic event. The procedures, as described in reference 3.9, to construct a fault tree also apply to success tree generation and are illustrated in figure 3-23. The commercial computer programs are similar, as are the cautions for use of probability values.

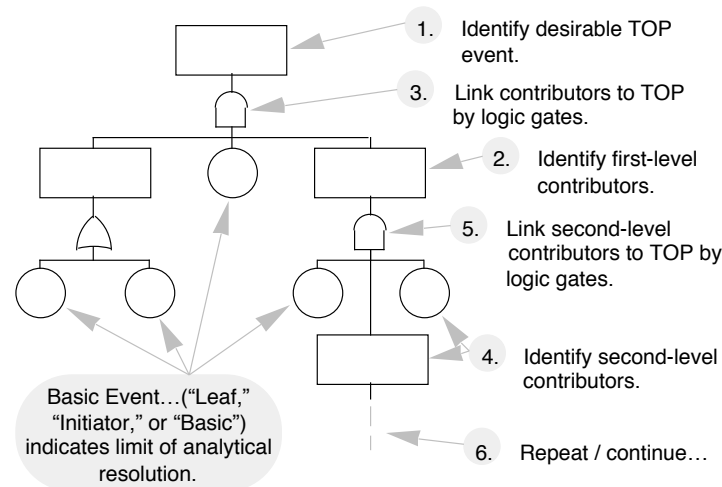

Figure 3-23. Success tree construction process.

A success tree can be constructed from a fault tree. Transform a success tree from a fault tree by simply changing all AND gates to OR gates and OR gates to AND gates, and restating each initiator, intermediate event, and top event as a success opposed to a failure.

Determine the probability of success ( $P_S$ ) for each basic event or initiator. Sources for these success probabilities may be found from manufacturer's data, industry consensus standards, MIL standards, historical evidence (of similar systems), simulation or testing, Delphi estimates, and the log average method. The Delphi technique (sec. 7.9) derives estimates from the consensus of experts. Remember that the probability of success equals reliability ( $R$ ) and may be determined from ( $P_F$ ) as shown in the following equation:

$$P_S = 1 - P_F .$$

Once probabilities are estimated for all basic events or initiators, propagate these probabilities through logic gates to the intermediate events and finally the TOP event. Use the expressions presented in table 3-7 to propagate probabilities through logic gates.

Generate cut sets and path sets in the same manner as for fault trees, as presented in sections 3.7.3.3 and 3.7.3.4, respectively.

### 3.7.4 Example

The compliment success tree for the fault tree presented in section 3.6.4 is presented in figure 3-24.

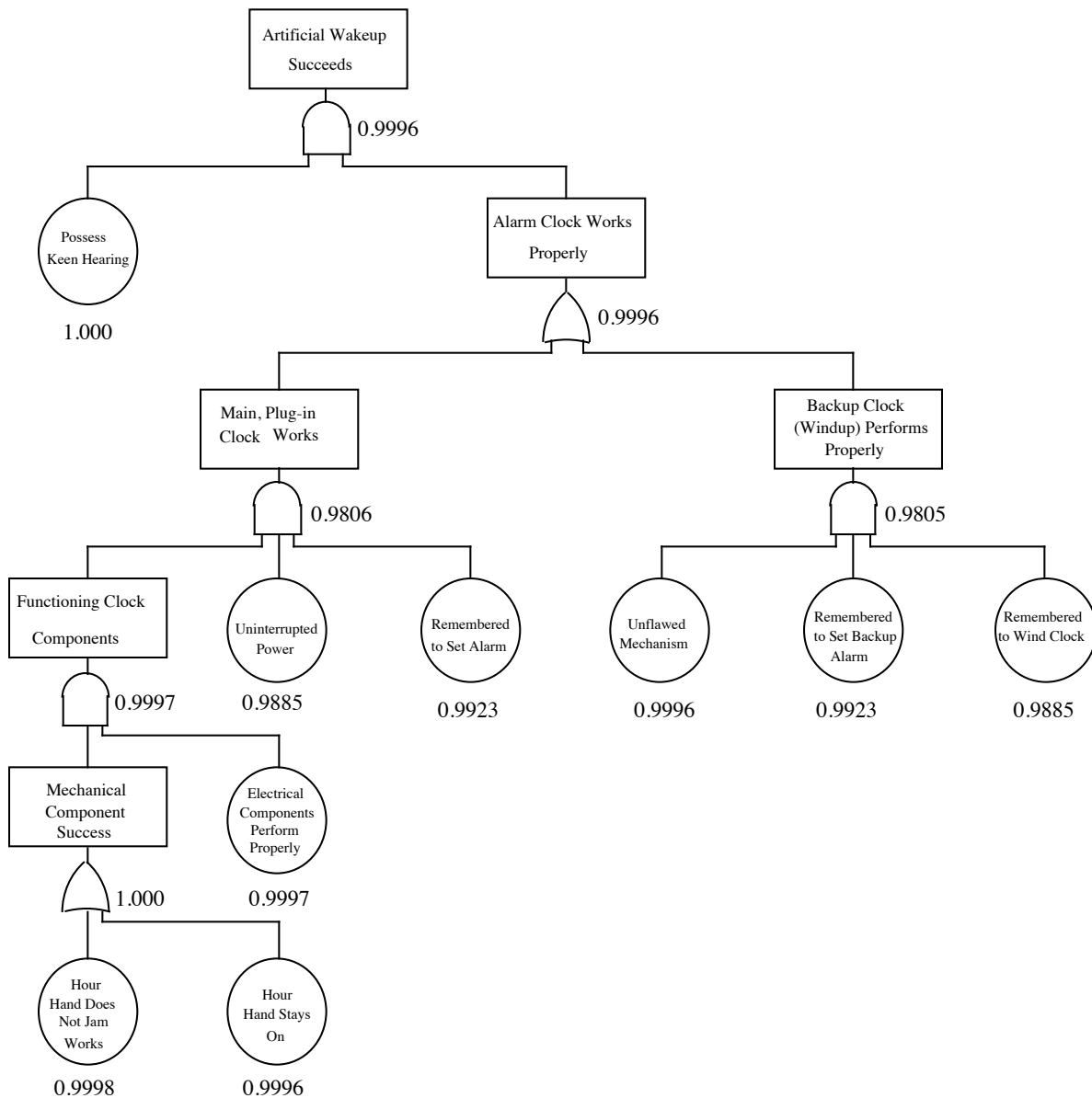

Figure 3-24. Example success tree.

### 3.7.5 Advantages

An STA provides the following advantages:<sup>3.9</sup>

- (1) Assesses probability of favorable outcome of system operation.
- (2) Compliments the FTA by providing a method to verify the logic of the fault tree.

### 3.7.6 Limitations

An STA possesses the following limitations:<sup>3.9</sup>

- (1) Address only one desirable condition or event that must be foreseen by the analyst. Thus, several or many STA's may be needed for a particular system.
- (2) Success trees used for probabilistic assessment of large systems may not fit/run on conventional PC-based software.
- (3) The generation of an accurate probabilistic assessment may require significant time and resources. Caution must be taken not to overdo the number generation portion.
- (4) A success tree is not accurate unless all significant contributors to system successes are anticipated.
- (5) Events or conditions under the same logic gate must be independent of each other.
- (6) Events or conditions at any level of the tree must be independent and immediate contributors to the next level event or condition.
- (7) The probability of success (reliability) of each initiator must be constant and predictable.

### 3.7.7 Bibliography

Henley, E.J., and Kumamoto, H.: "Probabilistic Risk Assessment." The Institute of Electrical and Electronic Engineers, Inc., New York, 1991.

## **3.8 Event Tree Analysis**

### 3.8.1 Description

An event tree analysis (ETA), as described in references 3.6 and 3.12, is a forward (bottom-up) symbolic logic modeling technique generated in both the success and failure domain. This technique explores system responses to an initiating "challenge" and enables assessment of the probability of an unfavorable or favorable outcome. The system challenge may be a failure or fault, an undesirable event, or a normal system operating command.



Reduce tree to simplified representation of system behavior. Use binary branching. Lead unrecoverable failures and undefeatable successes directly to final outcomes.

A fault tree or other analysis may be necessary to determine probability of the initiating event or condition. (Unity probability may be assumed.)

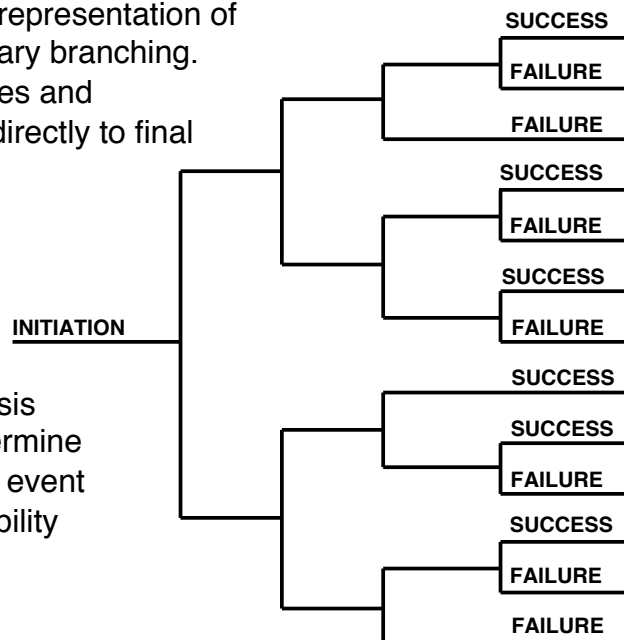

Figure 3-26. Event tree (Bernoulli model).

### 3.8.3 Procedures

The procedures, as described in reference 3.12, for performing an ETA are presented below.

- (1) Identify the initiating challenge to the system being examined.
- (2) Determine the paths (alternate logic sequences) by answering the question, "What happens when the system is challenged by the initiation event?" By convention, trace successful paths upwards and failure paths downwards.
  - a. For the general event tree, trace all plausible system operating permutations to a success or failure termination.
  - b. For the Bernoulli model event tree, use binary branching to show the system pathways. Simplify the tree by pruning unnecessary alternate branches of nonrecoverable failures or undefeatable successes.
- (3) Determine the probability of the initiating event by applying a fault tree (sec. 3.6) or other analysis. For a decision tree, assume the probability of the initiating event is one.
- (4) Determine the probability of each potential path by multiplying the individual probabilities of events making up the path.
- (5) Determine the probability of the system success by adding the probabilities for all paths terminating in success.
- (6) Determine the probability of the system failure by adding the probabilities for all paths terminating in failure.

### 3.8.4 Example

An example of an ETA is presented in figure 3-27. The example includes the system and scenario being assessed and the resulting event tree. Note that in this example the probability of the challenging initiator is assumed to be one and the tree has been pruned to its simplest form by using engineering logic. For example, since failure of the float switch is a nonrecoverable failure, its path leads directly to a final failure outcome with no alternate paths. In a similar manner since successful operation of the pump is an undefeatable success, its path also leads to a final success outcome with no alternate paths.

### 3.8.5 Advantages

An ETA provides the following advantages:

- (1) Enables the assessment of multiple, coexisting system faults and failures.
- (2) Functions simultaneously in the failure of success domain.
- (3) End events need not be anticipated.
- (4) Potential single-point failures, areas of system vulnerability, and low-payoff countermeasures are identified and assessed, thereby guiding deployment of resources for improved control of risk and optimized utilization of limited resources.
- (5) Failure propagation paths of a system can be identified and traced. This can be a “quick and dirty” comparative technique and provides very clear visibility of ineffective countermeasures.

### 3.8.6 Limitations

An ETA possesses the following limitations:

- (1) Address only one initiating challenge. Thus, multiple ETA's may be needed for a particular system.
- (2) The initiating challenge is not disclosed by the analysis, but must be foreseen by the analyst.
- (3) Operating pathways must be foreseen by the analyst.
- (4) Although multiple pathways to system failure may be disclosed, the levels of loss associated with particular pathways may not be distinguishable without additional analyses.
- (5) Specific, noncomparative success or failure probability estimates are typically difficult to find, difficult to achieve agreement on, and to successfully use to drive conclusions. Comparative analyses are typically as valuable, with better reception from the program and design teams.

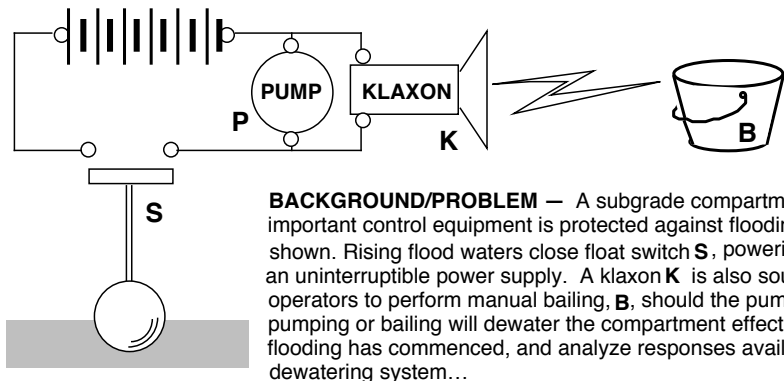

- Develop an event tree representing system responses.
- Develop a reliability block diagram for the system.
- Develop a fault tree for the TOP event *Failure to Dewater*.

**SIMPLIFYING ASSUMPTIONS:**

- Power is available full time.
- Treat only the four system components **S**, **P**, **K**, and **B**.
- Consider operator error as included within the bailing function, **B**.

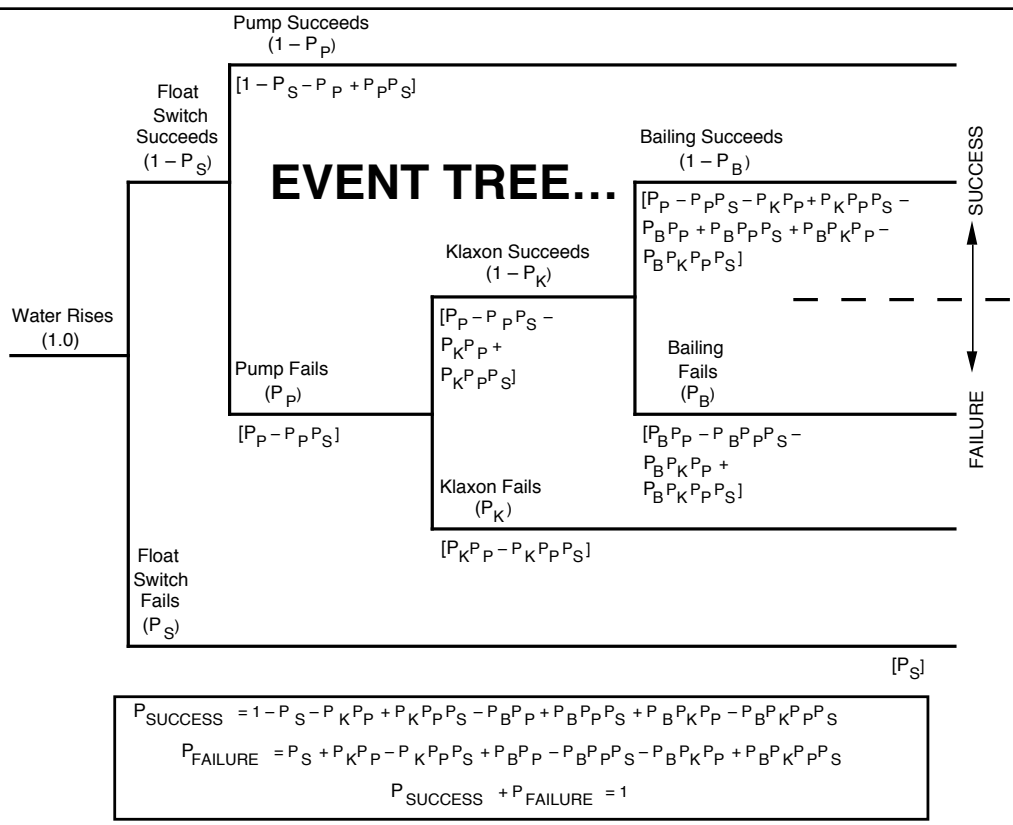

Figure 3-27. Example ETA.



### 3.8.7 Bibliography

Battelle Columbus Division, "Guidelines for Hazard Evaluation Procedures." 1985.

Henley, E.J., and Kumamoto, H., "Reliability Engineering and Risk Assessment." New York, 1981.

Lees, F.P. "Loss Prevention in the Process Industries." 2 vols., Butterworths, London, 1980.

## **3.9 Fault Tree, Reliability Block Diagram, and Event Tree Transformations**

### 3.9.1 Description

Fault trees (sec. 3.6), RBD's (sec. 3.5), and event trees (sec. 3.7) are all symbolic logic models. Fault trees are generated in the failure domain, reliability diagrams are generated in the success domain, and event trees are generated in the success and failure domains. These techniques, described in reference 3.13 and presented below, transform any one of the above models into the other two by translating equivalent logic from the success to failure or failure to success domain.

### 3.9.2 Application

These techniques are applicable by the analyst that wishes to exploit the benefits of the fault tree, RBD, and event tree. Fault trees offer the analyst comprehensive qualitative or quantitative analysis. RBD's offer the analyst a simplistic method to represent system logic. Event trees allow the analyst to assess a system in both the success and failure domains. This technique is typically performed in phase C but may also be performed in phase B.

### 3.9.3 Procedures

The procedures for transforming a fault tree, RBD, or event tree to either of the other two logic models are presented in the following sections.<sup>3.13</sup>

#### 3.9.3.1 Fault Tree to RBD Transformation

An RBD represents system component functions that, if these functions prevail, produces success in place of a TOP fault event. A fault tree can be transformed into a reliability diagram as illustrated in figure 3-28.

#### 3.9.3.2 RBD and Fault Tree-to-Event Tree Transformation

An event tree represents path sets in the success branches of the tree and all the cut sets in the failure branches of the tree. Therefore, if the path sets and cut sets of a system are known for a certain challenge to a system (TOP event of a fault tree), then an event tree can be constructed.

Cut sets and path sets may be obtained from a reliability diagram as shown in figure 3-29.

For large complex fault trees, cut sets and path sets are obtainable using the MOCUS algorithm described in sections 3.6.3.3 and 3.6.3.4, respectively.

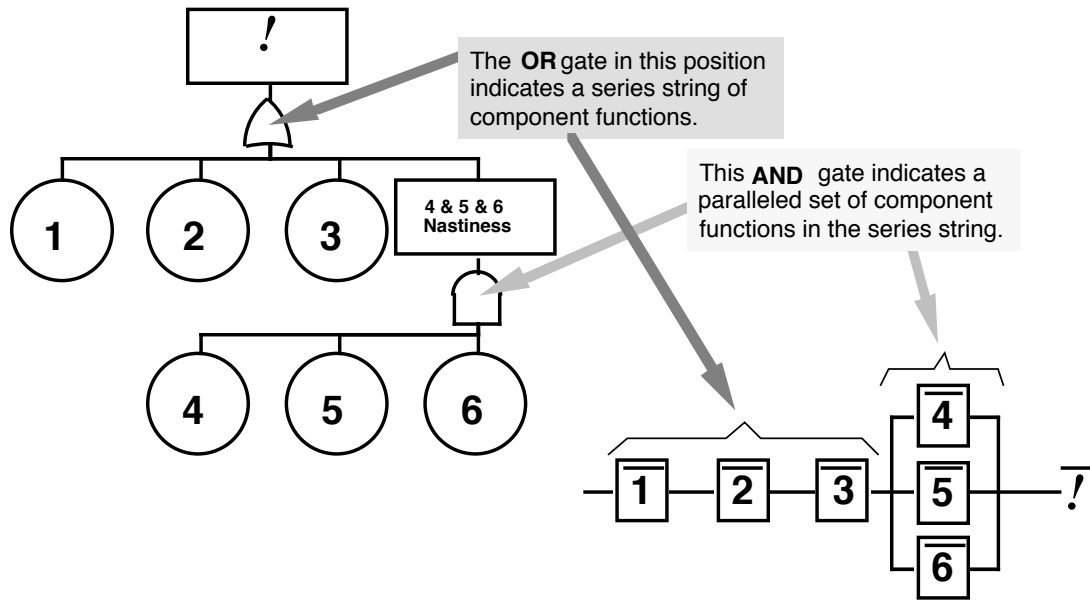

Figure 3-28. Fault tree to RBD transformation.

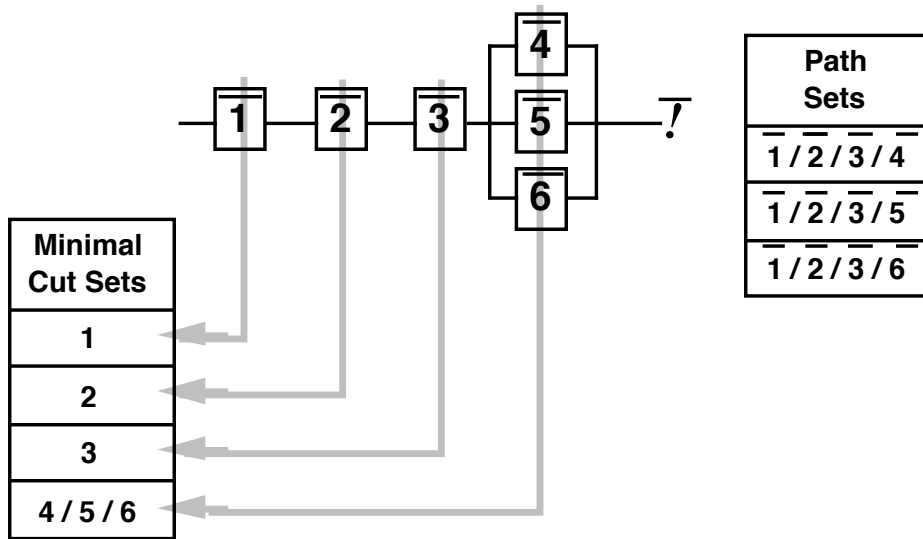

Figure 3-29. Deriving cut and path sets from an RBD.

To transform an RBD into an event tree, proceed as shown in figure 3-30. To transform a fault tree into an event tree, first transform the fault tree into an RBD (sec. 3.9.3.1).

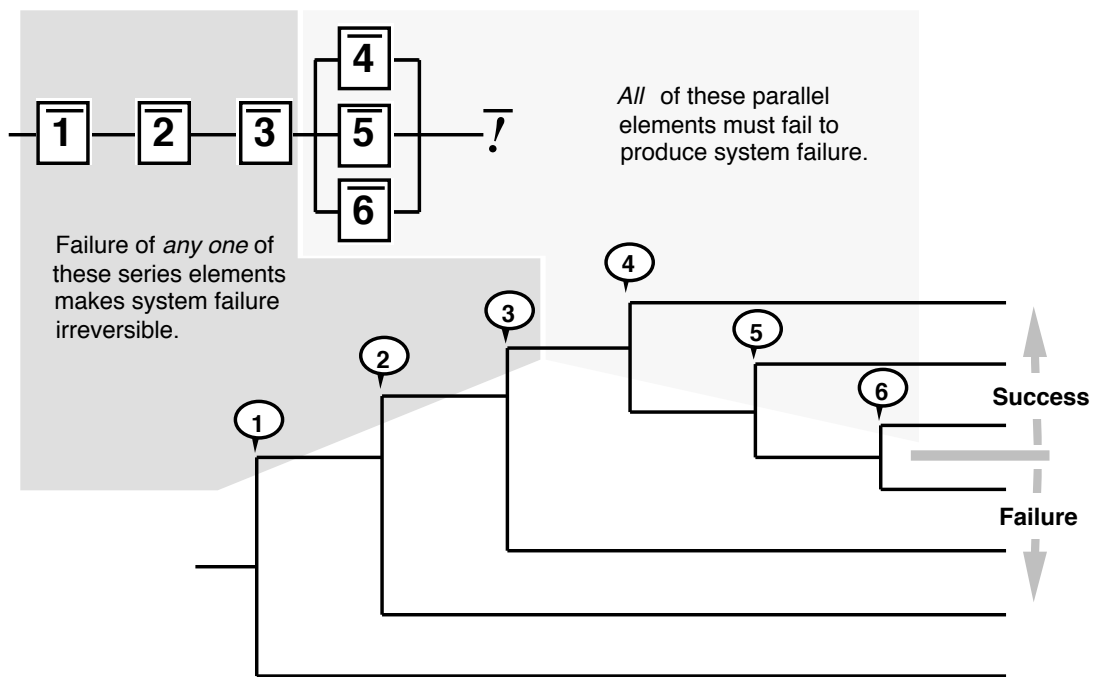

Figure 3-30. RBD to event tree transformation.

### 3.9.3.3 RBD to Fault Tree Transformation

A fault tree represents system functions which, if they fail, produce TOP event fault in place of the success to which the reliability block path lead. The series nodes of an RBD denote an OR gate beneath the TOP event of a fault tree. The parallel paths in an RBD denote the AND gate for redundant component functions in a fault tree. Therefore, a reliability diagram can be transformed into a fault tree as shown in figure 3-31.

### 3.9.3.4 Event Tree to RBD and Fault Tree Transformation

An event tree represents path sets in the success branches of the tree and all the cut sets in the failure branches of the tree. To transform an event tree into an RBD, reverse the process illustrated in figure 3-30. Once the RBD is formed, a fault tree can be formed as illustrated in figure 3-31. Also, an event tree can be transformed into a fault tree by inspection as shown in figure 3-32.

## 3.9.4 Example

An RBD and fault tree are transformed from the example event tree presented in figure 3-27, and presented in figure 3-33(a) and (b), respectively. All three of the models represent equivalent logic of the system.

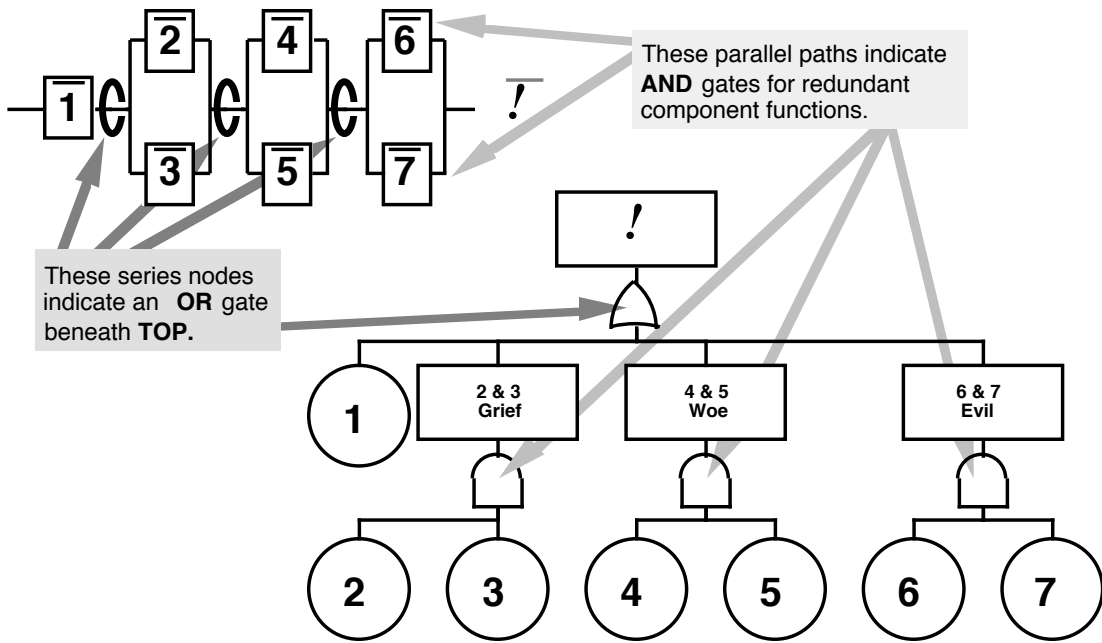

Figure 3-31. RBD to fault tree transformation.

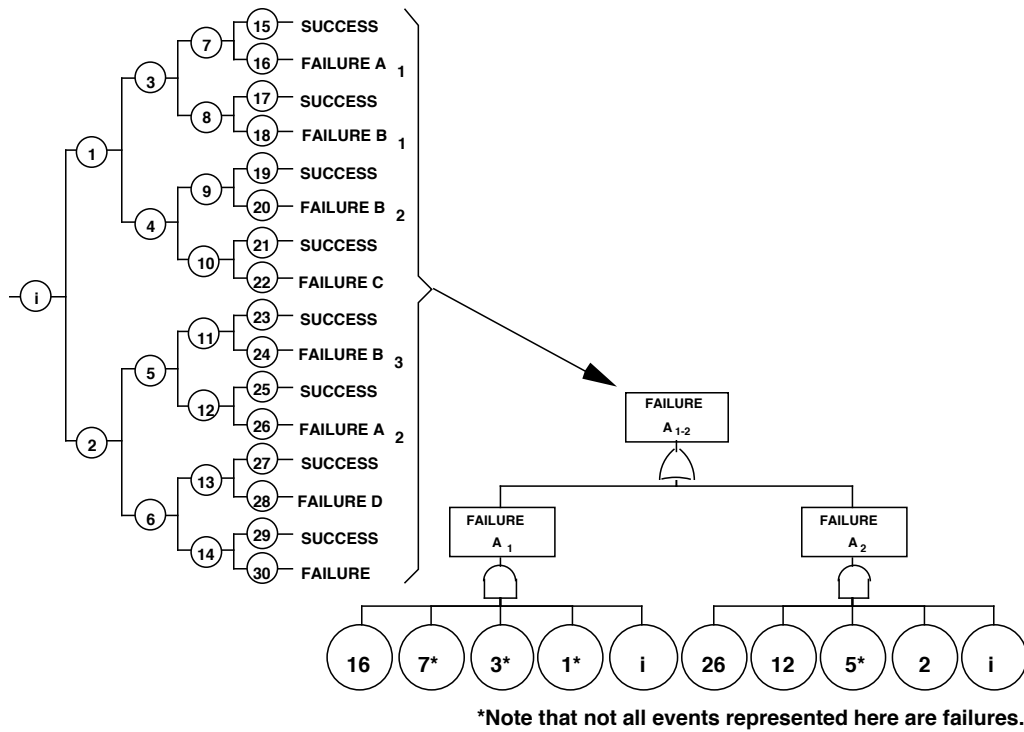
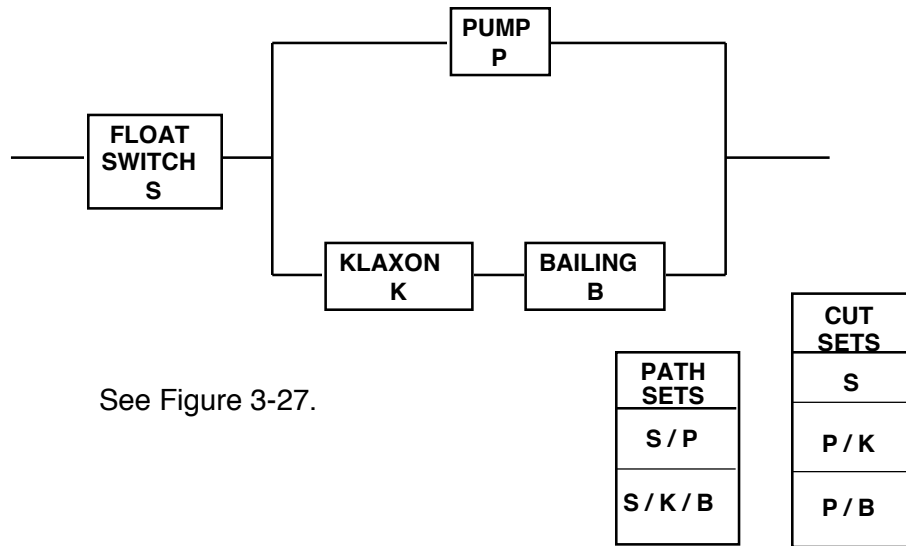

Figure 3-32. Event tree to fault tree transformation.



See Figure 3-27.

(a) RBD.

**EXACT SOLUTION:**

$$P_{TOP} = P_S + P_P P_K - P_P P_K P_S + P_B P_P - P_B P_P P_S - P_B P_K P_P + P_B P_K P_P P_S$$

**RARE EVENT APPROXIMATION:**

$$P_{TOP} = P_S + P_P P_K + P_P P_B$$

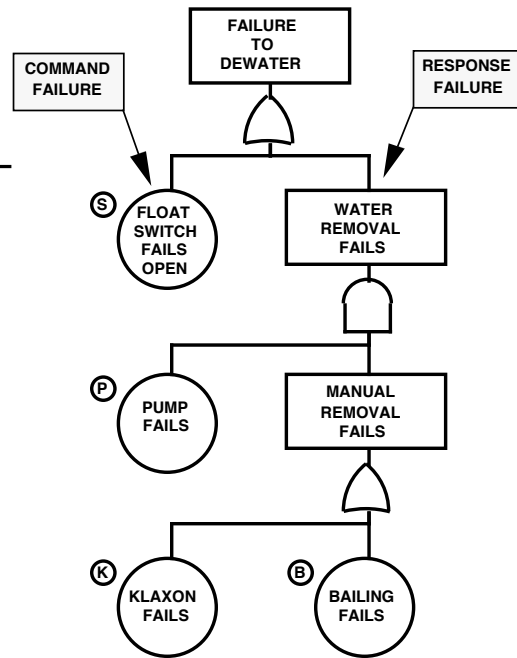
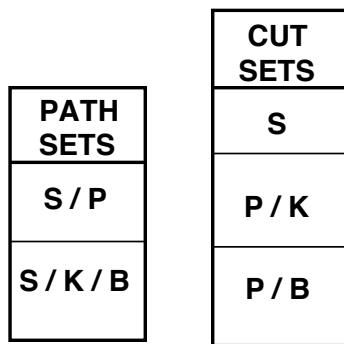

See Figure 3-27.

(b) Fault tree.

Figure 3-33. Equivalent logic RBD and fault tree.

### 3.9.5 Advantages

These techniques allow the analyst to overcome weaknesses of one analysis technique by transforming a system model into an equivalent logic model as another analysis technique. For example, a complex system that may be hard to model as a fault tree might be easily modeled with an RBD. Then, the RBD can be transformed into a fault tree, and extensive quantitative or pseudoquantitative analysis can be performed.

### 3.9.6 Limitations

These techniques possess the following limitations:

- (1) No new information concerning the system is obtained and the models are only as good as the models being transformed.
- (2) The cut sets and path sets required to perform these transformations for large complex systems may require many manhours or extensive computer resources to determine.

### 3.9.7 Bibliography

Gough, W.S., Riley, J., and Koren, J.M.: "A New Approach to the Analysis of Reliability Block Diagrams." Proceedings from Annual Reliability and Maintainability Symposium, SAIC, Los Altos, New Mexico, 1990.

## **3.10 Cause-Consequence Analysis**

### 3.10.1 Description

A cause-consequence analysis is a symbolic logic technique described in references 3.6 and 3.14, and presented below. This technique explores system responses to an initiating "challenge" and enables assessment of the probabilities of unfavorable outcomes at each of a number of mutually exclusive loss levels. The analyst starts with an initiating event and performs a forward (bottom-up) analysis using an event tree (sec. 3.8). This technique provides data similar to that available with an event tree; however, it affords two advantages over the event tree—time sequencing of events is better portrayed, and discrete, staged levels of outcome are analyzed.

The cause portion of this technique is a system challenge that may represent either a desired or undesired event or condition. The cause may be a fault tree TOP event and is normally, but not always, quantified as to probability. The consequence portion of this technique yields a display of potential outcomes representing incremental levels of success or failure. Each increment has an associated level of assumed or calculated probability, based on variations of response available within the system.

A conceptual illustration of how a cause is assessed to understand its consequences is presented in figure 3-34. Note that the cause has an associated probability, and each consequence has an associated severity and probability.

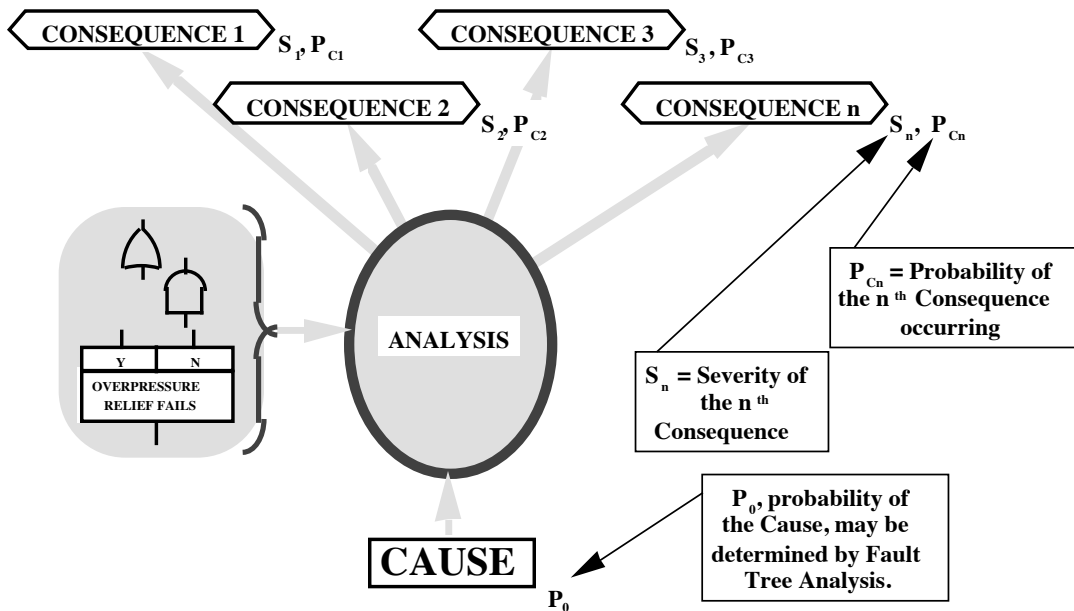

Figure 3-34. Relationship between cause and consequence.

### 3.10.2 Application

This technique is typically applied in phase C or E but may also be applied in phase D. The cause-consequence analysis is particularly useful in analyzing command-start/command-stop protective devices, emergency response systems, and engineered safety features. Cause-consequence analyses are useful in evaluating operating procedures, management decision options, and other nonhardware systems. Also, it will evaluate the effect/benefit of subtiered/redundant design countermeasures for design trades and assessment. This technique may be used in conjunction with an FTA to provide a technique sensitivity assessment. This technique may also be used to compliment an FMEA.





### 3.10.3 Procedures

The procedures, as described in references 3.6 and 3.14, for performing a cause-consequence analysis are presented below.

- (1) Identify the initiating event that challenges the system.
- (2) Determine the probability,  $P_0$ , that this event will occur. This probability may be determined from an FTA (sec. 3.6.3.2) or assumed.
- (3) Next, trace the possible consequences to the system from the initiating event. At various levels the path may branch with two possible outcomes. Construct the consequence diagram by asking the following questions:<sup>3,6</sup>
  - a. What circumstances allow this event to proceed to subsequent events?
  - b. What other events may occur under different system operating circumstances?

- c. What other system elements does this event influence?
- d. What subsequent event could possibly result as an outcome of this event?
- (4) Use the symbols presented in table 3-8 to construct the consequence diagram.

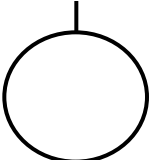
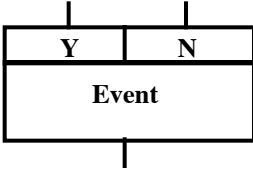
Table 3-8. Cause-consequence tree construction symbols.<sup>3,14</sup>

Symbol	Name	Description
	<b>OR Gate</b>	Gate opens to produce output when any input exists.
	<b>AND Gate</b>	Coexistence of all inputs opens gate and produces an output.
	<b>Basic Event</b>	An independent initiating event, representing the lower resolution limit of the analysis.
	<b>Branching Operator</b>	Output is "Yes" if condition is met and "No" if it is not met. Branching operator statement may be written in either the fault or the success domain. The outputs are mutually exclusive, therefore $P_Y + P_N = 1$ .
	<b>Consequence Descriptor</b>	End event/condition to which analysis leads, with the severity level stated.

- (5) The format of the consequence tree is presented in figure 3-35. Note that all paths lead into branching operators or consequence descriptors. The branching operator always has one input and two output paths (yes and no). The consequence descriptor has one input, no outputs, and is a termination point in the diagram.
- (6) For each branching operator, establish the probability,  $P_i$ , that the event can happen. Therefore,  $P_i$  and  $(1-P_i)$  are the probabilities for the yes and no paths from the branch operator, respectively. This step is often difficult and subjective due to a scarcity of data. Probability bands are often useful to provide an understanding of the analyst's confidence in the delineated probabilities.
- (7) Determine the probability of each consequence descriptor,  $P_{ci}$ , by multiplying event probabilities along the path that terminates at that consequence descriptor.
- (8) Finally, determine the severity of each consequence descriptor,  $S_i$ .



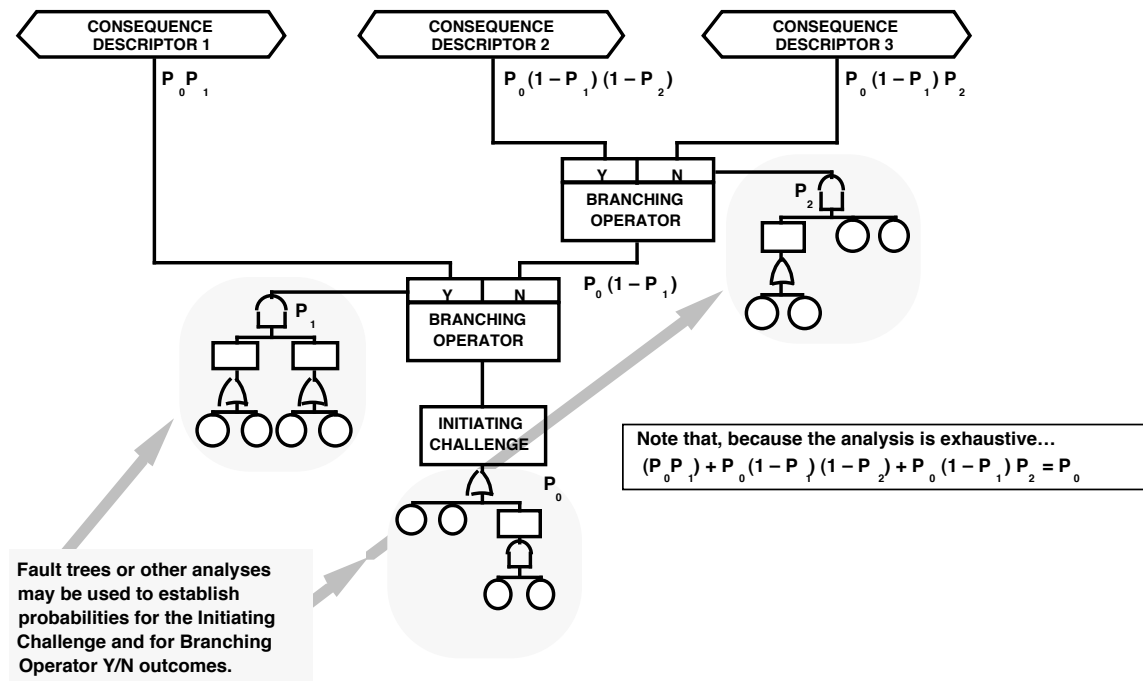

Figure 3-35. Cause-consequence analysis format.

### 3.10.4 Example\*

Problem:

A copying machine uses an electrically heated drum to fix dry ink to copy paper. The drum heater is thermostatically controlled. The drum is also equipped with an automatic overheat safety cutoff to prevent damage to the copier. The probability of failure is finite for both the drum thermostat and the overheat cutoff. Combustibles are often present in the copying room near the machine. Uncontrolled drum temperature can rise high enough to ignite them. The room is equipped with an automatic sprinkler system initiated by a heat detector. Employees frequent the room and can initiate an emergency response alarm in the event of fire. After a delay, a fire brigade responds to extinguish the blaze.

The cause-consequence analysis for the above problem is presented in figure 3-36.

### 3.10.5 Advantages

Cause-consequence analyses provide the following advantages:<sup>3.14</sup>

- (1) The analysis is not limited to a "worst-credible case" consequence for a given failure. Therefore, a less conservative, more realistic assessment is possible.
- (2) Enable assessment of multiple, coexisting system faults and failures.
- (3) End events need not be anticipated.
- (4) The time order of events is examined.

\*This example was provided courtesy of Sverdrup Technology, Inc., Tullahoma, Tennessee.<sup>3.1</sup>

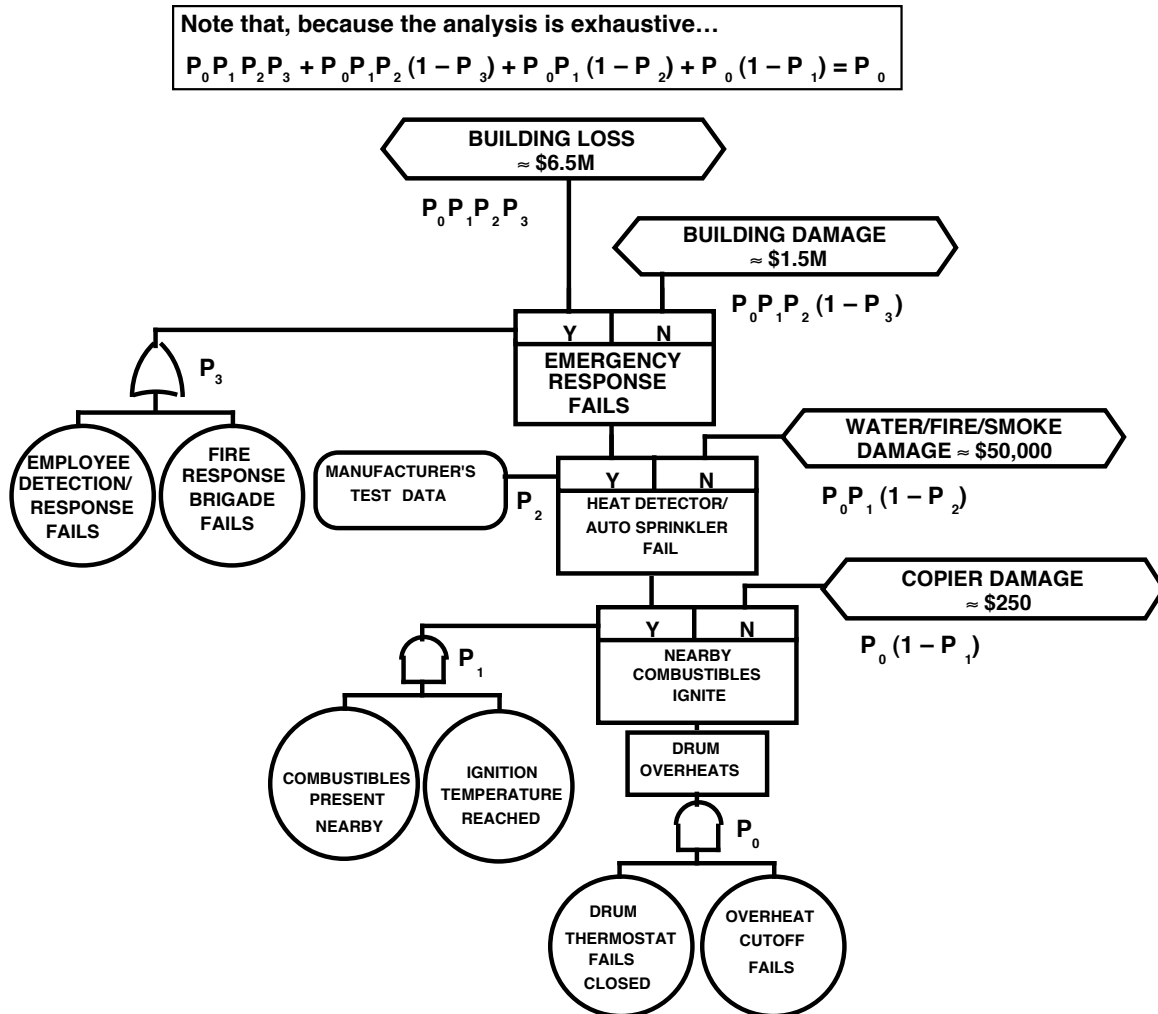

Figure 3-36. Example cause-consequence analysis.

- (5) Probabilities of unfavorable system operating consequences can be determined for a number of discrete, mutually exclusive levels of loss outcome. Therefore, the scale of partial successes and failures is discernible.
- (6) Potential single-point failures or successes, areas of system vulnerability, and low-payoff countermeasures are identified and assessed, thereby guiding deployment of resources for improved control of risk and optimized utilization of limited resources.

### 3.10.6 Limitations

Cause-consequence analyses possess the following limitations:<sup>3.14</sup>

- (1) Address only one initiating challenge. Thus, multiple analyses may be needed for a particular system.
- (2) The initiating challenge is not disclosed by the analysis, but must be foreseen by the analyst.

- (3) Operating pathways must be foreseen by the analysts.
- (4) The establishment of probabilities is often difficult and controversial.
- (5) Determining the severity on consequences may be subjective and difficult for the analyst to defend.

### 3.10.7 Bibliography

Battelle Columbus Division, "Guidelines for Hazard Evaluation Procedures." 1985.

Burdic, G.R., and Fussell, J.B.: "On the Adaptation of Cause-Consequence Analysis to U.S Nuclear Power Systems Reliability and Risk Assessment, System Reliability and Risk Assessment." JBF Associates, Inc., Knoxville, Tennessee, 1983.

Greenberg, H.R., and Cramer, J.J. "Risk Assessment and Risk Management for the Chemical Process Industry." Van Nostrand Reinhold, 1991.

Lees, F.P.: "Loss Prevention in the Process Industries." 2 vols, Butterworths, London, 1980.

## 3.11 Directed Graphic (Digraph) Matrix Analysis

### 3.11.1 Description

Directed graph (digraph) matrix analysis, as described in reference 3.15, is a technique using matrix representation of symbolic logic models to analyze functional system interactions. Logic models are first generated in the success domain, then converted into the failure domain. However, it should be noted that models can be directly created in the failure domain, without first creating the model in the success domain.

This technique consists of four phases. First, the analyst determines combinations of systems or combinations of subsystems within a single system for thorough assessment. This phase is parallel to determining failure propagation paths using an ETA (sec. 3.8). The second phase consists of constructing a digraph model in the success domain, then converting this model to a digraph model in the failure domain for each failure propagation path. The third phase consists of separating the digraph models into independent models, then determining the singleton and doubleton minimal cut-sets of each failure propagation path. Finally, the fourth phase consists of an assessment of the minimal cut sets relative to probability of occurrence.

### 3.11.2 Application

This technique, according to reference 3.15, can be used independently or as an element of a PRA (sec. 3.15). If this technique is used as part of a PRA, then it is performed after the identification of failure propagation paths by ETA but before FTA's are begun.<sup>3.15</sup> This technique is applied to evaluate the failure propagation paths involving several systems and their support systems, or within a single system involving several system elements (subsystem, component, part, etc.) and is best applied in phase B.

### 3.11.3 Procedures

Presented below is a summary of the detailed procedures found in reference 3.15 for performing a digraph matrix analysis.

- (1) Identify the associated group of systems (or associated system elements of a single system) to be thoroughly evaluated. Use event trees (sec. 3.8) to identify failure propagation paths. For a complete analysis, identify every credible initiator to an undesirable event and prepare an event tree that illustrates each specific failure propagation path.
  - a. Acquire pertinent information concerning the collection of systems to be assessed, such as design specifications and packages, safety assessment reports (such as PHA's, sec. 3.2), and prior safety or reliability studies.
  - b. Study checklists of potential initiating challenges. From these checklists develop a list of initiators that are applicable to the systems being studied.
  - c. Develop event trees for each initiating challenge to the system.
  - d. Prepare a list of failure propagation paths from step 1c. Assume unity probability for all systems required to work in the failure propagation path. This simplifying assumption leaves only failure propagation paths that are combinations of systems that must fail for a serious threat to be posed.
  
- (2) Construct a digraph model for each possible failure propagation path. Use a backward, top-down approach to construct a top-level digraph, then expand each element into its own digraph. Continue expanding the elements of new digraphs until the desired resolution level of the analysis is reached. An outline of the steps involved in producing the digraphs is presented below.
  - a. Create a success domain digraph model for each success path. Connect upstream elements to a downstream element with an AND gate if the upstream element relies on the successful operation of all the downstream components. Connect upstream elements to a downstream element with an OR gate if the upstream element relies on the successful operation of only one of two or more downstream elements. The symbols for AND and OR gates for a digraph are different than those used for a fault tree, however they represent the same logic as the fault tree symbols. A comparison between the digraph and fault tree symbols is presented in figure 3-37.
  - b. Form a failure domain model by taking the model generated in step 2a and interchange all AND gates with OR gates and all OR gates with AND gates. This failure domain model represents a path for failure propagation.
  - c. Form an adjacency matrix that represents the digraph. The matrix is constructed by the process illustrated in figure 3-38.

	AND Gate	OR Gate
Digraph		
Fault tree		
Represented logic	Event C will occur only if both event A and event B occur.	Event C will occur only if event A or event B occurs.

Figure 3-37. Comparison between digraph and fault tree logic gates.

- d. Next link all connected elements in the adjacency matrix. This is accomplished by processing the adjacency matrix with the reachability code. This code is described in detail in reference 3.15. The output of this code will show all elements connected by a path and illustrate which elements can be reached from a specific element, therefore all possible paths between pairs of nodes in the network. Next, use this information to determine singleton and doubleton cut sets.
  - e. Determine minimal singleton and doubleton cut sets from the cut sets determined in step 2d.
- (3) Subdivide the digraph into independent digraphs if the success domain digraph model becomes too large to determine singleton and doubleton cut sets for the computer platform being used. Then determine singleton and doubleton minimal cut sets of the smaller independent digraphs.
  - (4) Assess the singleton and doubleton minimal cut sets. This assessment can be conducted in a manner similar to that for a conventional PRA (sec. 3.15) in which risk is assessed with the probability of the cut sets occurring and the severity of the consequence of the failure propagation path.

Type	Digraph	Adjacency Matrix																
Direct connection		<table border="1"> <thead> <tr> <th></th> <th>A</th> <th>B</th> </tr> </thead> <tbody> <tr> <th>A</th> <td>0</td> <td>1</td> </tr> <tr> <th>B0</th> <td>0</td> <td></td> </tr> </tbody> </table>		A	B	A	0	1	B0	0								
	A	B																
A	0	1																
B0	0																	
AND gate		<table border="1"> <thead> <tr> <th></th> <th>A</th> <th>B</th> <th>C</th> </tr> </thead> <tbody> <tr> <th>A</th> <td>0</td> <td>0</td> <td>B</td> </tr> <tr> <th>B0</th> <td>0</td> <td>A</td> <td></td> </tr> <tr> <th>C0</th> <td>0</td> <td>0</td> <td></td> </tr> </tbody> </table>		A	B	C	A	0	0	B	B0	0	A		C0	0	0	
	A	B	C															
A	0	0	B															
B0	0	A																
C0	0	0																
OR gate		<table border="1"> <thead> <tr> <th></th> <th>A</th> <th>B</th> <th>C</th> </tr> </thead> <tbody> <tr> <th>A</th> <td>0</td> <td>0</td> <td>1</td> </tr> <tr> <th>B0</th> <td>0</td> <td>1</td> <td></td> </tr> <tr> <th>C0</th> <td>0</td> <td>0</td> <td></td> </tr> </tbody> </table>		A	B	C	A	0	0	1	B0	0	1		C0	0	0	
	A	B	C															
A	0	0	1															
B0	0	1																
C0	0	0																

Figure 3-38. Construction of digraph adjacency matrix.

#### 3.11.4 Example

An example digraph matrix analysis, adapted from reference 3.15, for a simple system is illustrated in figure 3-39. The system consists of two redundant power supplies to power a motor that drives a pump. The success domain model of this system is presented in figure 3-39(a). Note that this model represents the success path for successful operation of the pump. The failure domain model, presented in figure 3-39(b), was generated by replacing the OR gate in the success domain model with an AND gate. Inspection of the two models suggests that for simple systems the failure domain model can easily be generated without first generating the success model. In cases with more complex systems, first generating a success domain model may prove to be beneficial.

The adjacency matrix and adjacency elements are presented in figures 3-39(c) and (d), respectively. The adjacency matrix illustrates whether there is a direct path from node  $i$  to node  $j$ . If matrix element  $(i,j) = 1$ , there is a path from node  $i$  to node  $j$ . For example, element  $(M,P) = 1$ , which means there is a straight (uninterrupted) and unconditional path between the motor and pump. If element  $(i,j) = 0$ , there is no path from node  $i$  to  $j$ . For example, element  $(PS-1, PS-2) = 0$ , which means there is a no straight path between the main power supply and the auxiliary power supply. If the adjacency element  $(i,j)$  is  $\neq 0$  or 1, then there is a second component that must fail along with component  $i$  to cause component  $j$  to fail. For example, adjacency element  $(PS-1, M)$  is equal to  $PS-2$  (nonzero or 1 value).

This symbol represent the second component that must fail, given the failure of  $PS-1$ , to cause  $M$  to fail to operate (i.e., failure of both the main and auxiliary power supplies will cause the motor not to operate).

The reachability matrix and reachability elements are presented in figure 3-39(e) and (f), respectively. The methodology to generate the reachability matrix from the adjacency matrix is presented in reference 3.15. Simply stated, the reachability matrix illustrates the pairs of nodes that a path exists between, by connecting linked pairs from the adjacency matrix. Therefore the reachability matrix illustrates the complete pathways (through linked node pairs) of the graphical model elements illustrated by the adjacency matrix. Processing the adjacency matrix into the reachability matrix yields the paths between all pairs of nodes. The reachability elements are derived from the reachability matrix in the same manner that adjacency elements are derived from the adjacency matrix. Note, in this example, that the reachability elements include all the adjacent elements and the new information that if both  $PS-1$  and  $PS-2$  fail, then  $P$  will not operate (even though neither  $PS-1$  or  $PS-2$  are directly adjacent to  $P$ ). Therefore, the reachability matrix yielded the new information that if both power supplies failed, the pump will not operate.

The summary matrix presented in figure 3-39(g) illustrates which components can lead to failure of the pump,  $P$ . If an "\*" is entered as a matrix element ( $i,j$ ) and either  $i$  or  $j$  is a value of 1, then the other corresponding component  $i$  or  $j$  is a singleton. The only singleton in this system is the motor, i.e., the single failure of the motor will cause the pump not to operate. If a "\*" is entered as a matrix element ( $i,j$ ) that corresponds to component  $i$  and component  $j$ , then component  $i$  and component  $j$  form a doubleton. The only doubleton of this system is the pair of redundant power supplies, i.e., failure of both the main and auxiliary power supplies will cause the pump not to operate.

Obviously, in this example the singletons (single point failures) and doubletons (double point failures) could have easily been identified without performing a digraph matrix analysis. However, for complex systems which are modeled with many nodes and logic gates, this technique allows determination of singletons and doubletons which otherwise would not be as readily identified.

### 3.11.5 Advantages

The digraph matrix analysis provides the following advantages:<sup>3.15</sup>

- (1) The analysis allows the analyst to examine each failure propagation path through several systems and their support systems in one single model. Unlike the FTA with failure propagation paths divided in accordance to arbitrarily defined systems, this approach allows more rigorous subdividing of the independent subgraphs.
- (2) Since the technique identifies singleton and doubleton minimal cut sets without first determining all minimal cut sets, considerable computer resources can be saved over other methods such as the FTA.

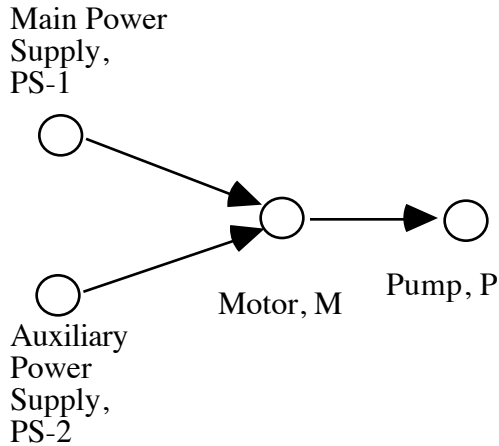

(a) Success domain model.

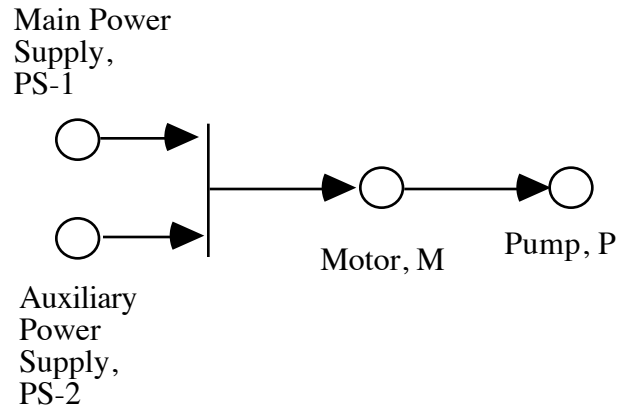

(b) Failure domain model.

	PS-1	PS-2	M	P
PS-1	0	0	PS-2	0
PS-2	0	0	PS-1	0
M	0	0	0	1
P	0	0	0	0

(c) Adjacency matrix.

PS-1, M, PS-2  
 PS-2, M, PS-1  
 M, P, 1

(d) Adjacency elements.

	PS-1	PS-2	M	P
PS-1	0	0	PS-2	PS-2
PS-2	0	0	PS-1	PS-1
M	0	0	0	1
P	0	0	0	0

(e) Reachability matrix.

PS-1, M, PS-2 (Adjacent)  
 PS-1, P, PS-2  
 PS-2, M, PS-1 (Adjacent)  
 PS-2, P, PS-1  
 M, P, 1 (Adjacent)

(f) Reachability element.

Figure 3-39. Example digraph matrix analysis—Continued



	1	PS-1	PS-2	M	P
1	-	-	-	*	-
PS-1	-	*	-	-	-
PS-2	-	-	*	-	-
M	*	-	-	-	-
P	-	-	-	-	-

→ Singletons: M  
Doubletons: PS-1, PS-2

(g) Summary matrix.

Figure 3-39. Example digraph matrix analysis—Continued.

### 3.11.6 Limitations

Digraph matrix analyses possess the following limitations.<sup>3.15</sup>

- (1) Trained analysts and computer codes to perform this technique may be limited.
- (2) For particular types of logic models, complete treatment may require more computer resources than FTA's.

### 3.11.7 Bibliography

Grumman Space Station Division, "Digraph Analysis Assessment Report." Reston Virginia, October 1991.

Kandel, A., and Avni, E.: "Engineering Risk and Hazard Assessment." vol. 2, CRC Press Inc., Boca Raton, Florida.

## 3.12 Combinatorial Failure Probability Analysis Using Subjective Information

### 3.12.1 Description

The combinatorial failure probability analysis using subjective information is described in reference 3.16 and presented below. This technique was developed by the System Effectiveness and Safety Technical Committee (SESTC) of the American Institute of Aeronautics and Astronautics (AIAA), in 1982. This technique provides the analyst a procedure to propagate probability data derived from the subjective probability scales defined in MIL-STD-882C.<sup>3.2</sup>

### 3.12.2 Application

This technique is typically performed in phase C and is applicable when no quantitative failure probability data are available and may be used in conjunction with other analyses such as an RBD (sec. 3.5), FTA (sec. 3.6), STA (sec. 3.7), ETA (sec. 3.8), and cause-consequence analysis (sec. 3.10).

### 3.12.3 Procedures

The procedures, as described in reference 3.16, for a combinatorial failure probability analysis using subjective information are presented below.

- (1) Arbitrary, dimensionless “probability values” have been assigned to the probability increments (frequent, probable, occasional, remote, and improbable) defined in MIL-STD-882C.<sup>3.2</sup> The subjective scale for these arbitrary values is presented in table 3-9. Descriptive words and definitions for the level of the scale are also given in this table.

Table 3-9. Combinatorial failure probability analysis subjective scale.

AIAA/SESTC		MIL-STD-882C		
Threshold Levels	Probability Level*	Level	Descriptive Word	Definition
$8 \times 10^{-2}$ to 1.00000	$3 \times 10^{-1}$	A	Frequent	Likely to occur frequently.
$8 \times 10^{-3}$ to $8 \times 10^{-2}$	$3 \times 10^{-2}$	B	Probable	Will occur several times in life of an item.
$8 \times 10^{-4}$ to $8 \times 10^{-3}$	$3 \times 10^{-3}$	C	Occasional	Likely to occur sometime in life on an item.
$8 \times 10^{-5}$ to $8 \times 10^{-4}$	$3 \times 10^{-4}$	D	Remote	Unlikely but possible to occur in life of an item.
0.00000 to $8 \times 10^{-5}$	$3 \times 10^{-4}$	E	Improbable	So unlikely if can be assumed occurrence may not be experienced.

\* Arbitrarily selected, dimensionless numbers.

Table provided courtesy of Sverdrup Technology, Inc., Tullahoma, Tennessee.

- (2) Estimate subjective failure probabilities of contributor events or conditions using the scale defined in MIL-STD-882C.<sup>3.2</sup> Select and consistently apply the same probability exposure interval (operating duration or number of events) for every initiator probability estimate used in the analysis.
- (3) Correlate the subjective estimate (step 2) with the arbitrary, dimensionless values (step 1). Propagate these values in the same manner as quantitative data is combined in classical numerical methods (such as presented in figs. 3-18 and 3-19).
- (4) Convert the final probability number resulting from propagation (step 3) back into the subjective scale defined in MIL-STD-882C.<sup>3.2</sup>

### 3.12.4 Example

The following example\* uses this subjective combinatorial technique in a fault tree problem.

#### Problem/Background:

- A large rotating machine has six main-shaft bearings. Replacement of a bearing costs \$18,000 and requires 3 wk of down time.
- Each bearing is served by:
  - pressurized lubrication oil
  - a water-cooled jacket
  - a temperature sensing/alarm/shutdown system.
- In addition, there are sensing/alarm/shutdown systems for:
  - lube pressure failure
  - cooling water loss of flow.
- If they function properly, these systems will stop operation of the rotating machine early enough to prevent bearing damage. (System sensitivity makes the necessary allowance for machine “roll-out” or “coasting.”)
- Failure records for the individual system components are not available, but probabilities can be estimated using the subjective scale of MIL–STD–882C.<sup>3.2</sup>

What is the probability that any one of the six bearings will suffer burnout during the coming decade?

The system schematic and fault tree are presented in figure 3-40(a) and (b), respectively. Note both the arbitrary subjective probability value and letter representing the relevant probability level from table 3-9 are presented for each fault tree initiator.

### 3.12.5 Advantages

This technique allows the analyst to perform a probabilistic assessment based on the exercise of subjective engineering judgment when no quantitative probability estimates are available.

### 3.12.6 Limitations

This technique should only be used when actual quantitative failure rate data is not available. The use of actual quantitative data is preferred over this method. This tool should only be used for comparative analysis only. Data and results, unless used in a comparative fashion, may be poorly received.

---

\*This example was provided courtesy of Sverdrup Technology, Inc., Tullahoma, Tennessee.<sup>3.16</sup>

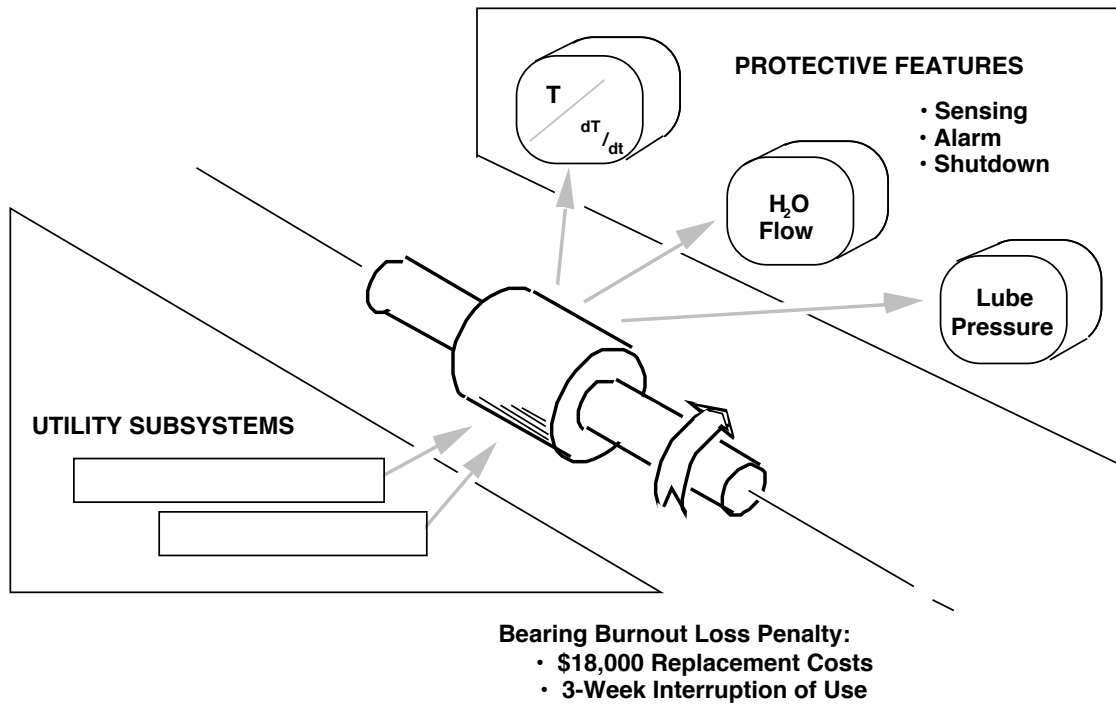

(a) System schematic.

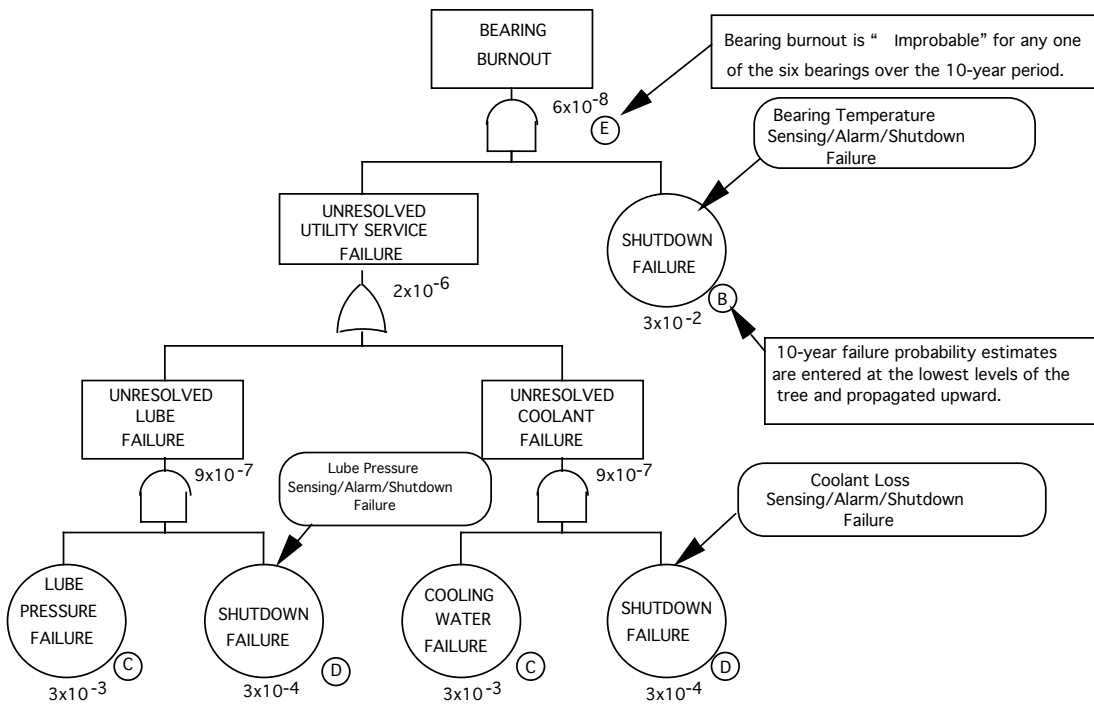

(b) System fault tree.

Figure 3-40. Example combinatorial failure probability analysis.

### 3.13 Failure Mode Information Propagation Modeling

#### 3.13.1 Description

Failure mode information propagation modeling is a qualitative analysis method described in reference 3.17 and presented below. This technique involves separating a system into its basic functional components and examines the benefit of measuring precedent failure information that may be transmitted between components of a system. This information may be transmitted during the initial outset of a variety of failure modes. The technique provides insight into both the types of information that should be measured to safeguard the system, and location within the system at which sensors might be appropriately positioned.

#### 3.13.2 Application

This technique effectively directs resource deployment to optimally safeguard a system against potential failures by identifying measurement requirements. These requirements are defined in terms of measured parameter, sensor type, and sensor location. This technique is best applied in phase C but may also be applied in phase D.

#### 3.13.3 Procedures

The procedures, as described in reference 3.17, to perform failure mode information propagation modeling are presented below.

- (1) Divide the system into its principle functional components and assign a number to each component. Like the FMEA (sec. 3.4), the resolution of this analysis is dependent upon the level (i.e., subsystems, assemblies, subassemblies, or piece parts) to which the system elements are resolved.
- (2) Identify the physical links (energy flow and shared stress) between the components of the system. These links include such items as electrical power, air flow, liquid flow, gas flow, thermal heat transfer, friction, spring, rolling element, etc.
- (3) Identify and record the failure modes for each component and assign a letter to each failure mode for each component.
- (4) Identify and record the flow of failure mode information at each physical link that is available externally to each component and transmitted to one or more other components.
- (5) Classify the failure mode information constituents by their signal characteristics (e.g., thermal, pressure, acceleration, etc.).
- (6) Identify the minimal success sets of the sensor network. A minimal success set is a sensor group that encompasses all failure modes.
- (7) Assess the various minimal success sets in terms of feasibility, cost, and effectiveness. The following questions should be asked:
  - a. Feasibility. Do the sensors currently exist or can they be developed? Can they be obtained in time to satisfy schedule requirements?

- b. Cost. Is the cost of installing, maintaining, and operating the sensor network less than the cost of the failure that the system is being safeguarded against?
- c. Effectiveness. Are there other preventive maintenance activities more effective than installing a sensor network? Will the sensing network forewarn before the start of system failures or does it just announce system crashes? Will the sensors impede normal system operation? Will they degrade system performance? Will they pose any new hazards to the system? Will the sensor network operate dependably? Will the sensors have adequate sensor redundancy?

### 3.13.4 Example

The following example\* uses failure mode information propagation modeling to a sensor network success set for a system.

#### Problem:

Consider a ventilating fan powered by an electric motor through a belt drive. A common frame structure supports both the motor and a bearing, through which power is delivered to the fan. (Consider motor bearings as integral parts of the motor.) Assume a constant aerodynamic fan load. A schematic of the system is presented in figure 3-41(a). Determine sensor network minimal success sets for the system.

#### Solution:

- (1) Perform steps 1–5 identified in section 3.13.3. These steps are explained below and illustrated in figure 3-41(b).
  - a. Step 1. Divide the system into its principle functional components and assign a number to each component. These are the electrical motor, fan belt, fan, frame, and bearing.
  - b. Step 2. Identify the physical links (energy flow and shared stress) between the components of the system. The electric motor, for example, has electrical power input, is linked to the fan belt by friction, and is mechanically and thermally linked to the frame.
  - c. Step 3. Identify and record the failure modes for each component and assign a letter to each failure mode. For example, the failure modes for the fan include shaft or rotor binding, bearing vibration, open winding, and shorted winding.
  - d. Step 4. Catalog the flow of failure mode information at each physical link that is available externally to each component and transmitted to one or more other components. For example, for the mechanical link between the electric motor and frame, the failure information available includes electric motor bearing vibrations (1–B), fan belt slipping and breaking (2–A/B), and bearing binding (5–A).
  - e. Step 5. Classify the failure mode information constituents by their signal characteristics. For example, the electric motor bearing vibration (1–B) and fan bearing vibration (5–B) can be monitored by an accelerometer at test point 4/1 (between frame, component 1 and electric motor, component 4).

---

\*This example was provided courtesy of Sverdrup Technology, Inc., Tullahoma, Tennessee.<sup>3.16</sup>

- (2) From the information displayed in figure 3-41(b), construct a matrix of failure mode versus sensor type (with each test point identified). Determine the minimum success sets of measurement sensors. These sets are sensor groups that encompass all failure modes. The matrix and minimum success sets for this system are presented in figure 3-41(c).

### 3.13.5 Advantages

Information propagation modeling provides the following advantages:<sup>3.17</sup>

- (1) Allows the analyst to identify measurement requirements, that, if implemented, can help safeguard a system by providing warnings at the onset of a failure mode that threatens the system.
- (2) Compliments an FMEA.

### 3.13.6 Limitations

Information propagation modeling possesses the following limitations:<sup>3.17</sup>

- (1) This technique is only applicable if the system is operating in a near-normal range, and for the instant of time immediately prior to the initiation of a failure mode.
- (2) Externally induced and common cause faults are not identified or addressed.
- (3) The risks of the failure modes are not quantified in terms of criticality and severity.
- (4) The propagation of a failure through the system is not addressed.

## **3.14 Probabilistic Design Analysis**

### 3.14.1 Description

A PDA, as described in references 3.8 and 3.18, is a methodology to assess relative component reliability for given failure modes. The component is characterized by a pair of transfer functions that represent the load (stress, or burden) that the component is placed under by a given failure mode, and capability (strength) the component has to withstand failure in that mode. The variables of these transfer functions are represented by probability density functions. Given that the probability distributions for both the load and capability functions are independent, the interference area of these two probability distributions is indicative of failure. Under these conditions, a point estimate for failure of the component relative to the failure mode under consideration can be determined.

### 3.14.2 Application

A PDA can be used to analyze the reliability of a component during phase C of a program. The PDA approach offers an alternative to the more traditional approach of using safety factors and margins to ensure component reliability. This traditional approach is vulnerable if significant experience and historical data are not available for components similar to that which is being considered.<sup>3.8 3.18</sup>

- Elements:**
- Electric Motor
  - Fan Belt
  - Bearing
  - Fan
  - Frame

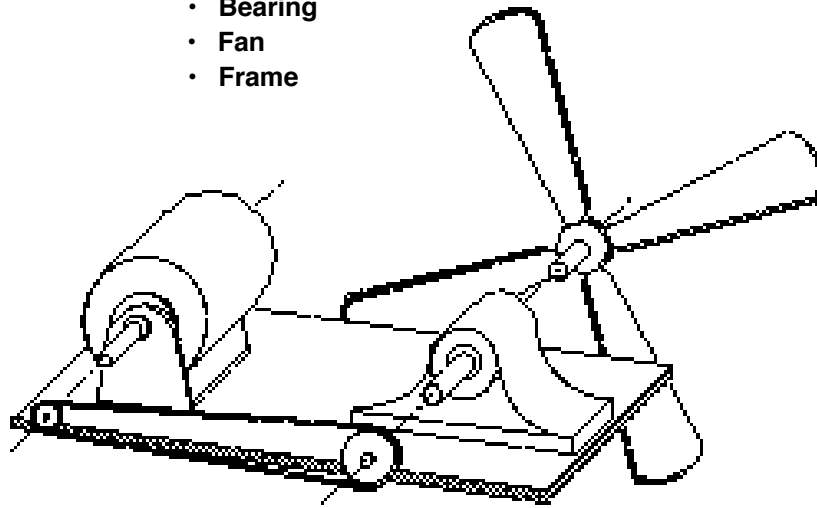

(a) System schematic.

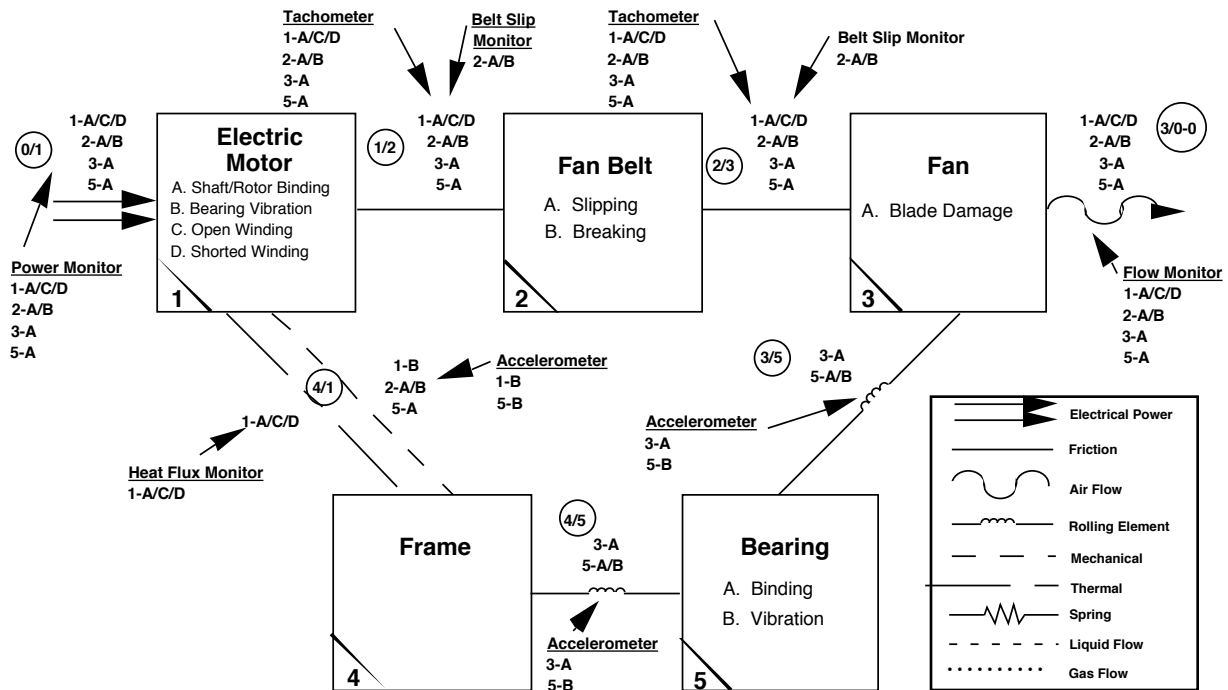

Model.

(b)

Figure 3-41. Example failure mode information propagation model—Continued



Failure Mode	Test Point									
	Sensor	Power Monitor	Tachometer	Belt Slip Monitor	Tachometer	Belt Slip Monitor	Flow Monitor	Accelerometer	Accelerometer	Accelerometer Heat Flux Monitor
		0/1	1/2	2/3	3/0-0	3/5	4/5	4/1		
1-A	✓	✓		✓		✓				✓
1-B									✓	
1-C	✓	✓		✓		✓				✓
1-D	✓	✓		✓		✓				✓
2-A	✓	✓	✓	✓	✓	✓				
2-B	✓	✓	✓	✓	✓	✓				
3-A	✓	✓		✓		✓	✓	✓		
4	Not Applicable									
5-A	✓	✓		✓		✓				
5-B							✓	✓	✓	

(c) Minimal success sets.

Figure 3-41. Example failure mode information propagation model—Continued.

### 3.14.3 Procedures

The procedures, adapted from reference 3.8 and 3.18, for performing a PDA in the context of a total design reliability program for a system are presented below.

- (1) Specify the system design requirements. These requirements should be stated in clear and concise terms that are measurable and verifiable.
- (2) Identify variables and parameters that are related to the design.
- (3) Identify the failure modes of the system by using a method such as a FMEA (sec. 3.4).
- (4) Confirm the selection of critical design parameters.
- (5) Establish relationships between the critical parameters and organizational, programmatic, and established failure criteria.
- (6) Ascertain the reliability associated with each critical failure mode with the following probabilistic analysis method:
  - a. Identify the random variables that effect the variation in the load to be imposed on the component for the given failure mode. Incorporate these random variables into a transfer function that represents this load (stress, or burden).

$$\text{Load Transfer Function: } L = f_L(X_1, X_2, X_3, \dots, X_n).$$

- b. Identify the random variables that affect the variation in the capability of the component to withstand the load imposed for the given failure mode. Incorporate these random variables into a transfer function that represent this capability (strength).

$$\text{Capability Transfer Function: } C = g_C(Y_1, Y_2, Y_3, \dots, Y_m).$$

- c. Gather data to perform the load and capability calculations.
- d. Determine probability distributions of the load (stress, or burden) and capability (strength) of the failure mode. Consider each variable of the transfer function as a probability density function (illustrated in figure 3-42). The density function can be represented as either a discrete variable distribution using empirical test data, or as a continuously variable form of the density function.

Note: The area under an entire probability density function curve is equal to a probability of one, therefore a range between two values of the independent random variable of a density function curve is equal to a probability less than or equal to one. Probability density functions of both load and capability continuous random variables for a given failure mode are presented in figure 3-43. Also illustrated in this figure is the interference of the load and capability density functions. For independent load and capability functions, this interference is indicative the failure mode will occur. In figure 3-43, both density functions are normal distributions with different means and variances. However, generally one or both of these density functions may be an exponential, log normal, gamma, Weibull, or other distribution.

- e. Calculate the reliability ( $R$ ) for the failure mode from the load and capability distributions. Reliability is the probability that the failure mode will not occur. The expression for reliability is:

$$R = 1 - P_F.$$

The expression for  $P_F$  is dependent upon the type of load and capability distributions. Expressions for  $P_F$  for various distributions are found in most advanced statistics textbooks and handbooks. Expressions for  $P_F$  between combinations of exponential, log normal, gamma, and Weibull distributions are found in reference 3.8.

- (7) Assess the reliability for each critical failure mode, including load and capability in this assessment, then modify the design to increase reliability. Repeat the process until the design reliability goals or requirements are met.
- (8) Perform trade studies (sec. 2.1) to reassess and optimize the design for performance, cost, environmental issues, maintainability, etc.
- (9) Repeat step 8 for each critical component for the system.
- (10) Determine the relative reliability of the system.
- (11) Repeat the above steps to optimize system reliability.

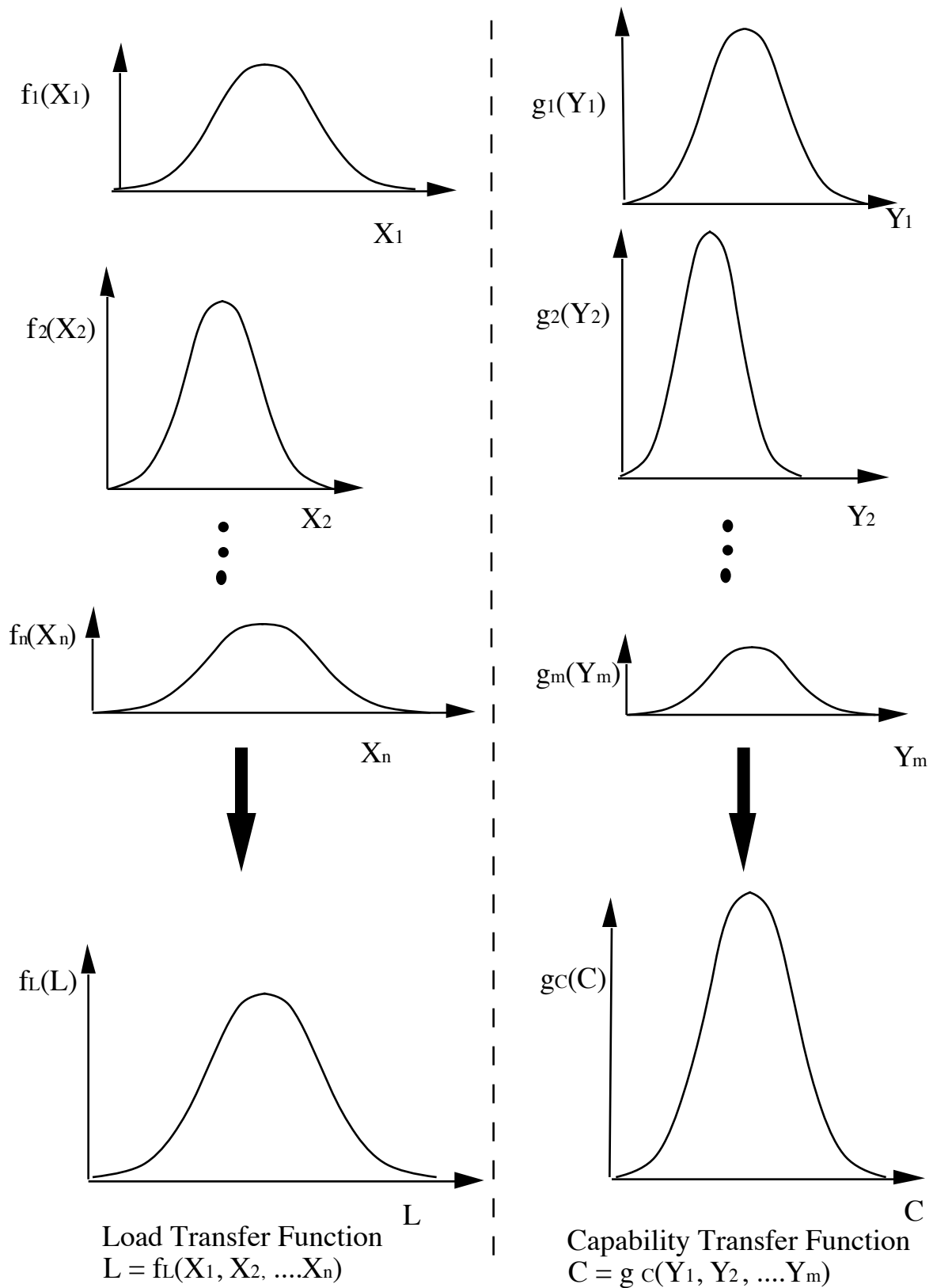

Figure 3-42. Load and capability transfer functions.<sup>3.8</sup>

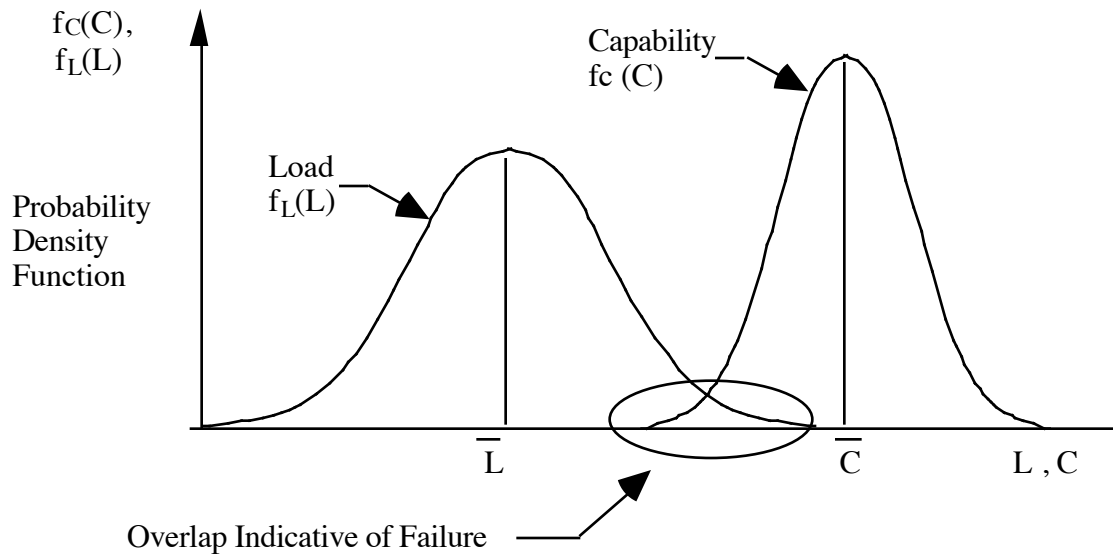

Figure 3-43. Interference between load and capability density functions.<sup>3.8</sup>

#### 3.14.4 Advantages

A PDA provides the following advantages:

- (1) Allows the analyst a practical method of quantitatively and statistically analyzing the relative reliability of a system during the design phase.<sup>3.8</sup> Therefore PDA's can be used to determine valuable areas of the design and aid in determining the resource allocation during the test and evaluation phase.
- (2) This technique mandates that the analyst address and quantify the uncertainty of design variables and understand its impact on system reliability of the design.<sup>3.8</sup>
- (3) The PDA approach offers a more accurate and truly quantitative alternative method to the more traditional approach of using safety factors and margins to ensure component reliability.<sup>3.8 3.18</sup>
- (4) The technique provides a more precise method for determining failure probabilities to support FTA's than does use of subjective methods.

#### 3.14.5 Limitations

A PDA possesses the following limitations:

- (1) The analyst must have experience in probability and statistical methods to apply this technique.<sup>3.8</sup>
- (2) Determining the density functions of the random variables in the load and capability transfer functions may be difficult.<sup>3.18</sup>
- (3) Historical population data used must be very close to the as-planned design population to be viable. Extrapolation between populations can render the technique nonviable.

- (4) This technique identifies the relative probabilities that various failure modes will occur, but does not address the severity of the failure modes. Therefore, this technique should be used as one element among other elements of a PRA (sec. 3.15) to assess the risk associated with the various failure modes.

### 3.15 Probabilistic Risk Assessment

#### 3.15.1 Description

A PRA is a general term given to methodologies that assess risk. Although PRA methods are customarily thought of as being quantitative, these methods can be either subjective (as by use of the risk assessment matrix, sec. 3.1), or quantitative in nature.

According to reference 3.6, a PRA generally consists of three phases. During phase 1, the system is defined, hazards are identified, elements of the system vulnerable to hazards are identified, and the overall scope of types of hazards to be assessed is defined. PHA's (sec. 3.2), are typically performed during phase 1.

During phase 2, the failure propagation paths and probabilities are established. ETA (sec. 3.8), FTA (sec. 3.6), FMECA (sec. 3.4) and/or cause-consequence analysis (sec. 3.10) are performed.

Finally, during phase 3, a consequence analysis is performed. Severity is established. Then, an assessment of risk is performed in terms of probability and severity, and by comparison to other societal risks.

#### 3.15.2 Application

A PRA is performed to identify consequence of failure in terms of potential injury to people, damage to equipment or facilities, or loss of mission requirements. The PRA is typically performed in phase C.

#### 3.15.3 Procedures

The following procedures, adopted from reference 3.6, offer guidance in performing a probabilistic risk assessment:

- (1) Phase 1 (activities performed during the preliminary design stage).
  - a. Define the system to be assessed, identify the elements (targets) of the systems that are susceptible to hazards, and from an overall perspective identify potential hazards.
  - b. Perform a PHA (sec. 3.2). In performing a PHA, the analyst: (1) identifies targets, (2) defines the scope of the system, (3) recognizes the acceptable risk limits, (4) identifies hazards, (5) assesses the risk for each hazard and target combination in terms of probability and severity, (6) and if the risk are unacceptable determines countermeasures to mitigate the risk, and (7) and repeats the assessment with the countermeasures incorporated.

- (2) Phase 2 (activities initiated after accomplishing hardware and configuration selections).
  - a. Identify failure propagation paths with techniques such as an ETA (sec. 3.8). In performing an ETA, the analyst (1) identifies an initiating challenge to the system, and (2) determines the alternate logic paths from the initiating event.
  - b. Determine initiators and propagate probability of failure with methods such as FTA (sec. 3.6). Probability of failure modes can also be determined with the probabilistic analysis method presented in section 3.14.
  - c. A cause-consequence analysis (sec. 3.10) may be performed to establish both failure propagation path and probabilities of causes and consequences.
  - d. A digraph-matrix analysis (sec. 3.11) may be performed after the ETA is complete and before FTA's have begun.<sup>3.15</sup>
  - e. An FMECA (sec. 3.4) may be performed. Examine all failure modes and criticality ranking of each system element.
- (3) Phase 3 (perform a consequence analysis).
  - a. Establish the severity of the failure modes.
  - b. Assess risk of all failure modes in terms of severity and probability.
  - c. Calibrate the risk of the system being examined by comparing it to other known societal risks.

#### 3.15.4 Advantages

Assessing risk avoids unknowingly accepting intolerable and senseless risk, allows operating decisions to be made, and improves resource distribution for control of loss resources.<sup>3.1</sup>

#### 3.15.5 Limitations

A PRA possesses the following limitations:

- (1) Probabilistic risk assessment requires skilled analysts. If the analyst is untrained in the various tools required, the tool could be misapplied or the results misinterpreted.
- (2) Depending on the size and complexity of the system being assessed, significant manhour and/or computer resources may be needed to complete.
- (3) Sufficient information and data may not be available to perform a thorough assessment.

## REFERENCES

- 3.1 Clemens, P.L.: "Working with the Risk Assessment Matrix." Second edition, Lecture Presentation, Sverdrup Technology, Inc., June 1993.
- 3.2 "System Safety Program Requirements." MIL-STD-882C, January 1993.
- 3.3 Mohr, R.R.: "Preliminary Hazard Analysis." Fourth edition, Lecture presentation, Sverdrup Technology, Inc., July 1993.
- 3.4 Clemens, P.L.: "Energy Flow/Barrier Analysis." Third edition, Lecture presentation, Sverdrup Technology, Inc., June 1993.
- 3.5 Mohr, R.R.: "Failure Modes and Effects Analysis." Sixth edition, Lecture presentation, Sverdrup Technology, Inc., October 1992.
- 3.6 Henley, E.J., and Kumamoto, H.: "Probabilistic Risk Assessment." The Institute of Electrical and Electronic Engineers, Inc., NY, 1991.
- 3.7 Gough, W.S., Riley, J., and Koren, James M.: "A New Approach to the Analysis of Reliability Block Diagrams." Proceedings from Annual Reliability and Maintainability Symposium, SAIC, Los Altos, NM, 1990.
- 3.8 Kampur, K.C., and Lamberson: "Reliability in Engineering Design." John Wiley & Sons, NY, 1977.
- 3.9 Clemens, P.L.: "Fault Tree Analysis." Fourth edition, Lecture presentation, Sverdrup Technology, Inc., May 1993.
- 3.10 Swain, A.D., and Guttman, H.E.: "Handbook of Human Reliability Analysis with Emphasis on Nuclear Power Plant Applications." NUREG/CR-1278.
- 3.11 Briscoe, Glen J.: "Risk Management Guide." System Safety Development Center, SSDC-11, DOE 76-45/11, September 1982.
- 3.12 Clemens, P.L.: "Event Tree Analysis." Second edition, Lecture presentation, Sverdrup Technology, Inc., June 1990.
- 3.13 Clemens, P.L.: "Transformations, Fault Tree/Reliability Block Diagram/Event Tree." Lecture presentation, Sverdrup Technology, Inc., November 1992.
- 3.14 Clemens, P.L.: "Cause-Consequence Analysis." Third edition, Lecture presentation, Sverdrup Technology, Inc., December 1992.
- 3.15 Alesso, H.P., Sacks, I.J., and Smith, C.F.: "Initial Guidance on Digraph-Matrix Analysis for System Interaction Studies." Lawrence Livermore National Laboratory, March 1983.
- 3.16 Clemens, P.L.: "Combinatorial Failure Probability Analysis Using MIL-STD-882B," Fourth edition, Lecture presentation, Sverdrup Technology, Inc., August 1991.
- 3.17 Clemens, P.L.: "Failure Information Propagation Modeling." Second edition, Lecture presentation, Sverdrup Technology, Inc., October 1989.
- 3.18 "Solid Propulsion Reliability Guidebook." The Phillips Laboratory and the Engineering Society for Advancing Mobility Land, Sea, Air, and Space (SAE), vol. 2, draft, June 1992.

## 4. DESIGN-RELATED ANALYTICAL TOOLS

Two design-related analytical tools (sensitivity analysis and tolerance stackup analysis) that can be useful to systems engineering are discussed in this section. In addition, Geometric Dimensioning and Tolerancing, ANSI-Y-14.5, is discussed. This section is included to give the systems engineer an understanding of the standard methods of dimensioning and tolerancing.

A summary of the advantages and limitations of each tool or methodology discussed in this section is presented in table 4-1.

### 4.1 Sensitivity (Parametric) Analysis

#### 4.1.1 Description

In sensitivity analysis, sensitivity functions (or coefficients of influence) are generated by taking partial derivatives with respect to each parameter that affects the outcome of a relationship.

#### 4.1.2 Application

Sensitivity analysis typically should be performed in phase C or D. This analysis can be used for nearly any type of relationship. Sensitivity analysis is especially useful when environmental conditions can change, when factors such as age affect performance, or when manufacturing tolerances affect performance. Sensitivity analysis can show which parameters affect a system the most or least. This can facilitate optimizing a system, reducing variability, or adjusting a system for wear or changing conditions. Typical examples of the use of sensitivity analysis are manufacturing formulation and processes (e.g., bond strength, burn rate, erosion rate, or material strength).

#### 4.1.3 Procedures

The procedure for obtaining the sensitivity of a relationship by analytical methods is as follows:

- (1) Generate an equation for the relationship under consideration.
- (2) Find the coefficients of influence<sup>4.1</sup> by taking the partial derivatives for each parameter under consideration.
- (3) Solve the equations for the coefficients of influence to find the sensitivity at given conditions.

An alternate approach to approximate sensitivity is to assume a straight-line relationship between two points in the sample space of the relationship, and to solve the relationship for two conditions represented by two values of the parameters in question. This method is often preferred for relationships with parameters that are interrelated, such as throat area and exit pressure in the thrust equation.



Table 4-1. Design-related analytical tools and methodologies.

Tool or Methodology	Section	Advantages	Limitations
Sensitivity (parametric) analysis	4.1	The effect of each parameter can be assessed to determine which parameters have the greatest effect on the outcome of a process and which parameters can yield the most benefit from adjustment.	It is often not easy to isolate a variable to obtain a second derivative. For example, when obtaining the sensitivity of thrust to throat diameter, changing a throat diameter not only changes motor pressure, but changes the nozzle expansion ratio and exit pressure. The pressure ratio is typically found by iteration or by tables. If the approximation approach above is taken, care must be used to ensure a small enough range for parameter values to achieve the desired accuracy.
Standard dimensioning and tolerancing	4.2	Dimensioning and tolerancing per ANSI-Y-14.5 is fairly standard. In addition, some aspects of dimensioning and tolerancing per ANSI-Y-14.5 are better suited for production. For example, true positioning allows for a circular tolerance zone, whereas putting tolerances to rectangular coordinates allows a square tolerance zone. Thus, a functional part that would comply with true position tolerances may not comply with rectangular tolerances. Dimensioning strategy can minimize the cumulative tolerance stackup. This is facilitated by following the dimensioning and tolerancing system of ANSI-Y-14.5.	A moderate amount of training and practice is required to effectively use standard dimensioning and tolerancing.
Tolerance stackup analysis	4.3	Worst-case tolerance analysis can simply determine the envelope of possible form, fit, and function. Statistical analysis can show that, even if exceeding a requirement is possible, it may be extremely unlikely.	Worst-case tolerance analysis is conservative in that when many tolerances combine, it becomes increasingly unlikely that all dimensions will be simultaneously worst-case. Statistical tolerance analysis usually assumes a normal distribution of dimensions in the tolerance zone, which may be unrealistic. In addition, care must be exercised when combining tolerances, in that: <ul style="list-style-type: none"> <li>(1) If some tolerances are much smaller than others, their inclusion in tolerance stackup analysis is superfluous. Consideration of significant digits may be helpful, e.g., a 0.030 tolerance may have a smallest unit of measurement greater than a 0.0005 tolerance.</li> <li>(2) It may be superfluous to combine tolerances from different manufacturing processes, e.g., machining and casting.</li> </ul>

#### 4.1.4 Example

In the following hypothetical example, the sensitivity of pressure with respect to throat area is being determined. The equation for this analysis is the pressure equation. The equation for pressure is:

$$P_c = r_b \frac{C^* \rho}{g} \frac{A_s}{A^*} \quad (4.1)$$

where  $P_c$  is the chamber pressure,  $r_b$  is the propellant burn rate,  $C^*$  is the propellant gas characteristic exhaust velocity,  $\rho$  is the propellant density,  $g$  is gravity,  $A_s$  is the propellant burn surface area, and  $A^*$  is the throat area. To find the sensitivity of pressure to motor throat area, take the partial derivative of equation (4.1) with respect to  $A^*$ .  $\Delta P_c$  is taken over a narrow range where  $r_b$  is approximately constant.

$$\frac{\partial P_c}{\partial A^*} = - \left[ r_b \frac{C^* \rho}{g} A_s \right] \frac{1}{(A^*)^2} \quad (4.2)$$

where  $\partial$  designates a partial derivative. The sensitivity is found by substituting values for the variability into the partial derivative equation. Numbers can be substituted into equation (4.2) to obtain the slope at a particular value of  $A^*$ . It is intuitively obvious that the relationship between the partial derivative and  $A^*$  is both negative and inversely proportional to  $A^{*2}$ .

Another example of the approximation method is the substitution of selected values into the thrust equation (4.6). The sensitivity of thrust to throat area is to be investigated for a hypothetical motor with the following characteristics:

$$A_s = 300 \text{ in}^2$$

$$A^* = 1.9 \text{ in}^2, 2.1 \text{ in}^2$$

$$A_e = 10 \text{ in}^2$$

$$\rho = 0.06 \text{ lbm/in}^3$$

$$\gamma = 1.2$$

$$r_b = 0.5 \text{ in/s}$$

$$C^* = 5100 \text{ in/s}$$

$$g = 386.40 \text{ in/s}^2.$$

The first step is to calculate the chamber pressure, substituting into equation (4.1), using the first value of  $A^*$  which is  $1.9 \text{ in}^2$ . The next step is to calculate Mach number ( $M$ ) iteratively from equation (4.3):

$$\left( \frac{A_e}{A^*} \right)^2 = \frac{1}{M^2} \left[ \frac{2}{\gamma + 1} \left( 1 + \frac{\gamma - 1}{2} M^2 \right) \right]^{\frac{\gamma + 1}{\gamma - 1}}. \quad (4.3)$$

The third step is to calculate nozzle exit plane pressure ( $P_e$ ) from equation (4.4).

$$\frac{P_e}{P_c} = \frac{1}{\left[1 + \frac{\gamma - 1}{2} M^2\right]^{\frac{\gamma}{\gamma - 1}}} \quad (4.4)$$

The next step is to calculate the thrust coefficient ( $C_F$ ) from equation (4.5).

$$C_F = \left\{ \left[ \frac{2\gamma^2}{\gamma - 1} \left( \frac{2}{\gamma + 1} \right)^{\frac{\gamma + 1}{\gamma - 1}} \right] \left[ 1 - \left( \frac{P_e}{P_c} \right)^{\frac{\gamma - 1}{\gamma}} \right] \right\}^{\frac{1}{2}} \quad (4.5)$$

The final step is to calculate thrust ( $T$ ) from equation (4.6).

$$T = C_F A^* P_c . \quad (4.6)$$

The above calculations should be performed again, using  $A^* = 2.1 \text{ in}^2$ . The values obtained from both calculations are shown in table 4-2.

Table 4-2. Sensitivity analysis calculations.

	$P_c$	$M$	$P_e$	$C_F$	$T$
$A^* = 1.9 \text{ in}^2$	62.52	2.82	1.87	1.50	177.62
$A^* = 2.1 \text{ in}^2$	56.57	2.75	1.93	1.47	174.60

Conclusion:

The thrust ( $T$ ) is inversely proportional to the throat area ( $A^*$ ).

#### 4.1.5 Advantages

The effect of each parameter can be assessed to determine which parameters have the greatest effect on the outcome of a process, and which parameters can yield the most benefit for adjustment.

#### 4.1.6 Limitations

It is often not easy to isolate a variable to obtain a second derivative. For example, when obtaining the sensitivity of thrust to throat diameter, changing a throat diameter not only changes motor pressure, but changes the nozzle expansion ratio and exit pressure. The pressure ratio is typically found by iteration or by tables. If the approximation approach above is taken, care must be used to ensure a small enough range for the parameter values to achieve the desired accuracy.

## 4.2 Standard Dimensioning and Tolerancing

### 4.2.1 Description

Dimensioning and tolerancing on drawings is complicated enough to yield confusion, unless standardized methods are employed at all stages of a project life from design to manufacture. Standard dimensioning and tolerancing per ANSI-Y-14.5 is an internationally recognized method of stating dimensions and tolerances.

### 4.2.2 Application

Standard dimensioning and tolerancing is typically applied in phase C but the technique could also be applied in phase D. Standard dimensioning and tolerancing allows the design engineer to indicate how tolerances are to be applied. This information is understood by draftsmen, manufacturing engineers, and machinists to assure the form, fit, and function intended by the design engineer (or systems engineer). Some of the methods of specifying dimensions and tolerances are discussed here.

### 4.2.3 Procedures

This section explains how dimensions and tolerances are specified on design drawings.<sup>4.3</sup> Following is a list of feature controls used to specify how a tolerance is to be applied to a design feature, from ANSI-Y-14.5:

—	straightness	∠	angularity
▭	flatness	⊥	perpendicularity
○	circularity	//	parallelism
⊘	cylindricity	⊕	position
⌒	profile of a line	◎	concentricity
⌒	profile of a surface	↗	circular runout
⊠	datum identifying letter	↖	total runout
⊠	basic dimension	(XXX)	reference dimension

A basic dimension is contained in a box (unless otherwise specified on the drawing). Basic dimensions are the controlling dimensions on a drawing, and have no tolerances associated with them. Basic dimensions set up a dimensional pattern, such as a bolt pattern. The locations of the features in the pattern (e.g., bolt holes or threads) are toleranced using true-position tolerances. Often the title block of a drawing will indicate standard tolerances peculiar to that drawing that will apply to all basic dimensions shown without a specified tolerance. A tolerance is shown for each significant digit used in the basic dimensions on the drawing. For example, a tolerance of  $\pm 0.1$  may apply to all basic dimensions with one significant digit.

Reference dimensions are the result of basic dimensions. In the example below, an inner and coincident outer diameter are specified; the thickness is a reference dimension. In this situation, the inner and outer diameters are of primary importance; the thickness is of secondary importance.

A rectangular box is used as a feature control box. The symbol in the first section of the box is for the type of tolerance (e.g., true position). The first symbol in the second section is the type of measurement (a diametrical tolerance is shown in fig. 4-1). The number is the size of the tolerance. The second symbol in the second section (a circle with the letter “M,” “L,” or “R”) specifies the relation of the tolerance with the size of the feature. The third (and any subsequent) section specifies which data are used (which feature or dimension the tolerances concern).

#### 4.2.4 Example

Following is a hypothetical fixed nozzle assembly used to show the purpose of dimension and tolerance methods:

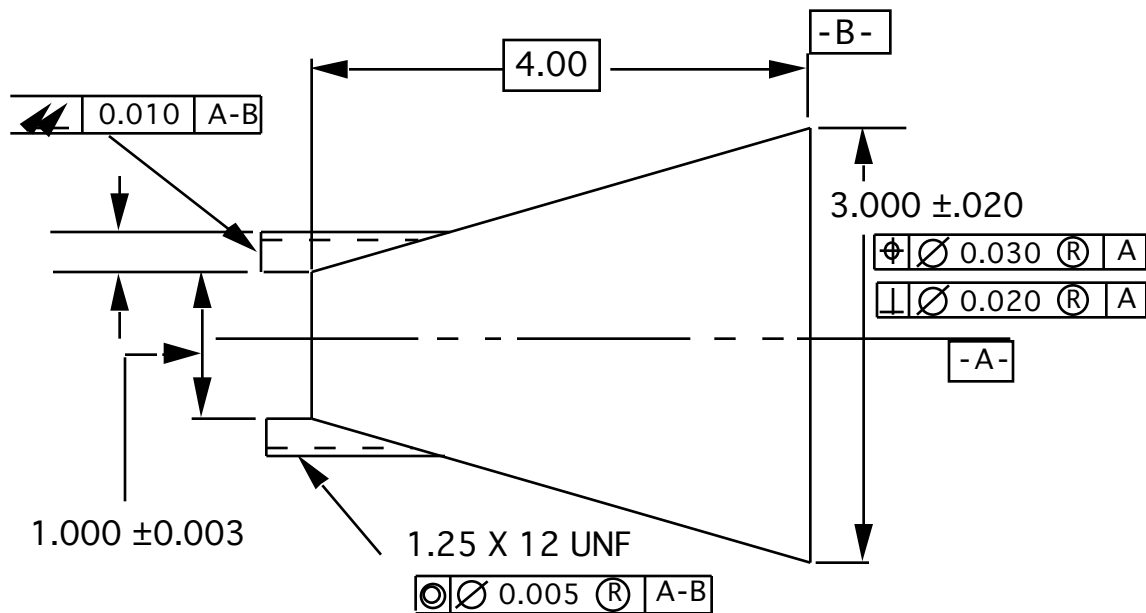

Figure 4-1. Example of dimensioning and tolerancing.

In this example, datum A is defined by the throat of the nozzle, thus datum A is the axis of the throat. The nozzle exit is referenced to datum A. The true position of the exit is to be within  $\pm 0.030$  of the throat axis (datum A), and the exit plane is to be within a  $0.020$  tolerance zone perpendicular to the throat axis. The true position tolerance is not affected by the feature size of the throat diameter. (The “R” inside the circle indicates that the position tolerance is applied “regardless of feature size.” An “M” inside the circle would denote that the position tolerance applies to “maximum material condition;” thus the tolerance can be relaxed by an amount commensurate with the difference that the size of the feature is less than the maximum allowable size. An “L” inside the circle would denote “least material condition” where the tolerance applies to the smallest feature size allowable.) The exit plane also defines datum B.

The boss at the end of the nozzle is controlled by a total runout tolerance. The surface is to be within a  $0.010$  tolerance zone perpendicular to the axis made by the throat and exit (datums A and B). The threads of the nozzle are to be concentric to the throat and exit axis within  $0.005$ , and the axis of the threads is to be within  $\pm 0.015$  of the throat axis. Note that for the profile type tolerance controls (e.g.,

runout or perpendicularity), the number defines a tolerance zone. This means that the total “width” of the acceptable deviation is defined by the tolerance. Thus a tolerance zone of 0.020 is analogous to a  $\pm 0.010$  tolerance. For position tolerances, the number call out is  $\pm$ , thus the axis of the nozzle exit must fall inside a circle of 0.030 radius around the throat axis.

Note that the tolerances in this example control the thrust vector. The length of the nozzle is controlled by a basic dimension. The exit is true-positioned to the basic dimension from the nozzle throat, and the required perpendicularity to the throat axis is greater than the true position tolerance. The nozzle exit is toleranced to keep the thrust vector in line (within a certain amount) with the throat axis. The nozzle boss is controlled by runout to the axis defined by the throat and exit plane. The boss surface tolerance is to facilitate a consistent seal with the motor. The thread is controlled by concentricity to the same axis to keep the thrust axis in line with the motor axis. It can be seen that the thickness of the boss is not a controlling dimension; it is a reference dimension. If this dimension were not specified, the form, fit, or function of the component would not be affected.

#### 4.2.5 Advantages

Dimensioning and tolerancing per ANSI-Y-14.5 is fairly standard. In addition, some aspects of dimensioning and tolerancing per ANSI-Y-14.5 are better suited for production. For example, true positioning allows for a circular tolerance zone, whereas putting tolerances to rectangular coordinates allows a square tolerance zone. Thus, a functional part that would comply with true position tolerances may not comply with rectangular tolerances. Dimensioning strategy can minimize the cumulative tolerance stackup. This is facilitated by following the dimensioning and tolerancing system of ANSI-Y-14.5.

#### 4.2.6 Limitations

A moderate amount of training and practice is required to effectively use standard dimensioning and tolerancing.

### 4.3 Tolerance Stackup Analysis

#### 4.3.1 Description

Tolerance stackup analysis determines if a form, fit, or function problem exists when manufacturing tolerances combine in a finished part or assembly. Tolerance stackup analysis is typically performed by either assuming worst-case allowable dimensions, or by using statistical analysis of tolerances.

#### 4.3.2 Application

Tolerance stackup analysis is typically performed in phase C or D. This technique is used to determine the possibility or probability of having form, fit, or function problems with a design, or to determine a tolerance or dimension necessary to avoid form, fit, or function problems.

#### 4.3.3 Procedures

Three typical methods for tolerance stackup analysis are:

- (1) Worst-case tolerance stackup analysis, used to determine size or position if all applicable dimensions occur at the worst-case extremes of the tolerance zones simultaneously.

- (2) Statistical analysis of tolerances, used where the expected standard deviations of tolerances are combined to determine the probability of a final tolerance.<sup>4.4</sup>
- (3) Design using simulation methods, where a computer is used to do a Monte Carlo analysis of the possible combinations of tolerances.<sup>4.5</sup>

#### 4.3.4 Example

In the following hypothetical O-ring joint assembly (fig. 4-2), the tolerances of each component are shown in figure 4-3. Find the maximum tolerance stackup possible to obtain the minimum squeeze, and the probability that the squeeze will be less than 0.035. The nominal squeeze is 0.050 inches.

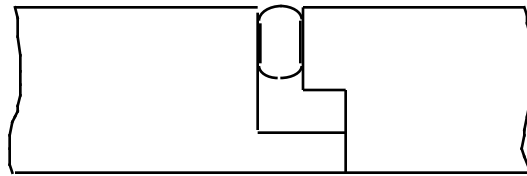

Figure 4-2. O-ring joint.

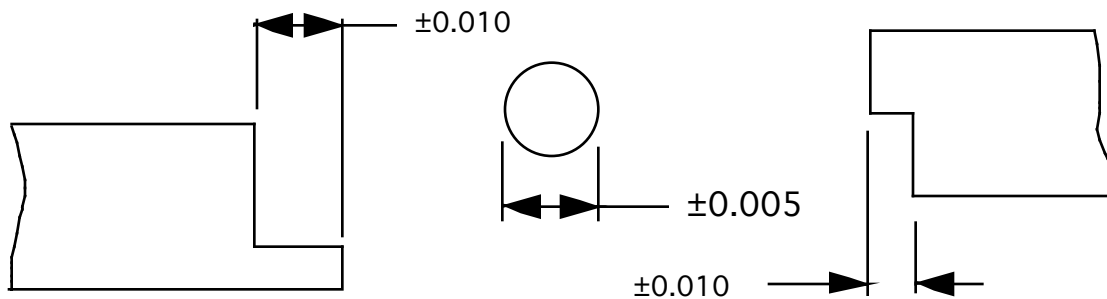

Figure 4-3. O-ring joint components.

The probability of the squeeze being less than 0.035 is obtained by finding the distance from the mean (in terms of standard deviations) that this condition represents. The standard deviation is assumed to be one third of the tolerance on the parts (this means all parts will fall within 3 standard deviations of the nominal dimension) and is therefore:

$$\text{Component standard deviation} = 0.010/3 = 0.0033$$

$$\text{O-ring standard deviation} = 0.005/3 = 0.00167$$

and by summation of squares,

$$\text{system standard deviation} = (2(0.0033)^2 + (0.00167)^2)^{.5} = 0.005.$$

For a squeeze of 0.035, the distance (in standard deviations) from the mean ( $z$ ) is

$$z = (0.035 - 0.050)/0.005 = -3.0.$$

Using a table for the normal distribution function, the area under the half curve for  $z = \pm 3$  is 0.4987. Since this is a one-sided question (no interest in the squeeze being 0.065), the area under the curve beyond  $z = 3$  is  $(0.5 - 0.4987) = 0.0013$ . This value is interpreted as 0.13 percent probability that the squeeze on the O-ring will be 0.035 or less.

A close look at the example above will show that more sources of variation are possible than those considered. For example, the surfaces compressing the O-ring may not be flat or normal to the direction of squeeze. Also, position tolerances are often determined at maximum material condition, thus position can vary more when not at maximum material condition. It can be extremely cumbersome to perform a statistical analysis of all the possible variations on some assemblies, so software exists to perform the statistical analysis. A typical example of software is the “Variation Simulation Analysis”<sup>4.5</sup> that uses Monte Carlo methods to simulate the possible ways that the tolerances can stack up.<sup>4.3 4.4</sup> The results can be used to determine probabilities that certain overall tolerances will exceed a critical value, or which tolerances are most important to form, fit, or function.

#### 4.3.5 Advantages

Worst-case tolerance analysis can simply determine the envelope of possible form, fit, and function. Statistical analysis can show that, even if exceeding a requirement is possible, it may be extremely unlikely.

#### 4.3.6 Limitations

Worst-case tolerance analysis is conservative, in that when many tolerances combine, it becomes increasingly unlikely that all dimensions will be worst-case simultaneously. Statistical tolerance analysis usually assumes a normal distribution of dimensions in the tolerance zone, which may be unrealistic. In addition, care must be exercised when combining tolerances, in that:

- (1) If some tolerances are much smaller than others, their inclusion in tolerance stackup analysis is superfluous. Consideration of significant digits may be helpful, e.g., a 0.030 tolerance may have a smallest unit of measurement greater than a 0.0005 tolerance.
- (2) It may be superfluous to combine tolerances from different manufacturing processes, e.g., machining and casting.

#### 4.3.7 Bibliography

Craig, M.: “Managing Variation by Design Using Simulation Methods.” Applied Computer Solutions, Inc.



## REFERENCES

- 4.1 “System Sensitivity Analysis.” Edited by J.B. Cruz, Jr., Dowden, Hutchinson and Rose, Inc. Stroudsburg, PA.
- 4.2 Hill, P.G., and Peterson, C.R.: “Mechanics and Dynamics of Propulsion.” Third edition, Addison-Wesley Publishing Company, Reading, MA, November 1970.
- 4.3 “Dimensioning and Tolerancing.” ANSI-Y-14.5M, The American Society of Mechanical Engineers, United Engineering Center, 345 East 47th Street, New York, NY 10017, 1982.
- 4.4 Shigley, J.E.: “Mechanical Engineering Design.” Third edition, McGraw-Hill.
- 4.5 “Variation Simulation Analysis Software, Getting Started Manual.” Applied Computer Solutions Inc., 300 Maple Park Blvd., St. Clair Shores, MI 48081.

## 5. GRAPHICAL DATA INTERPRETATION TOOLS

There are numerous excellent texts on the appropriate use of graphical data interpretation tools. While this section lists and briefly discusses some of the available tools, the neophyte reader is advised to read and utilize standard handbook references when using these techniques in problem solving to avoid misuse and error. This toolbox is to provide knowledge of the existence of these techniques, and references for their appropriate application.

One way to analyze data is by graphical interpretation. The analysis can be used to monitor performance, identify relationships, and reveal the most important variables in a set of data. The scatter diagram, section 5.1, makes it possible to determine if any relationship exists between two variables. The control chart, section 5.2, monitors the performance of a process with frequent outputs. Control charts are useful in trend analysis, section 8, and statistical process control, section 7.14. The bar chart compares quantities of data to help identify distribution patterns. This chart is discussed in section 5.3.

One of the most common data displays is the time-line chart, section 5.4. This chart displays changes over time. Sorting data that share a common characteristic into different groups is often accomplished with a stratification chart. This chart is discussed in section 5.5. A Pareto chart, section 5.6, is used typically when there is a need to know the relative importance of data or variables. This chart will also identify the problems, causes, or conditions that occur most frequently. A histogram, section 5.7, is a bar chart that shows a dispersion of data over a specified range. This type of chart is commonly used in presentations to make data easier to interpret.

A summary of the advantages and limitations of each tool or methodology discussed in this section is presented in table 5-1.

### 5.1 Scatter Diagram

#### 5.1.1 Description

Scatter diagrams, also called XY graphs, plot raw data and allow the analyst to determine if any relationship exists between two variables. No interpretation of the data should be attempted, but correlations can be inferred.<sup>5.1</sup>

#### 5.1.2 Application

The graphic display of the scatter diagram can help one determine possible causes of problems, even when the connection between two variables is unexpected. The direction and compactness of the cluster of points gives a clue as to the strength of the relationship between the variables. The more that this cluster resembles a straight line, the stronger the correlation between the variables. The scatter diagram technique is best applied in phase E.

The scatter diagram displays one variable on the horizontal (X) axis and the other variable on the vertical (Y) axis. If there is a correlation between the two variables, positive or negative, it can be assumed if the data from one are changed, then this will effect the data from the other.<sup>5.2</sup>

Table 5-1. Graphical data interpretation tools and methodologies.

Tool or Methodology	Section	Advantages	Limitations
Scatter diagram	5.1	<ul style="list-style-type: none"> <li>(1) The general relationship between two variables can be determined at a glance.</li> <li>(2) The graph can help determine a possible cause(s) of problems by looking at correlations.</li> </ul>	<ul style="list-style-type: none"> <li>(1) The choice of scale for the graph can distort the data, thus possibly giving the appearance of a correlation that is better or worse than reality.</li> <li>(2) The correlation does not prove a cause-and-effect relationship.</li> </ul>
Control chart	5.2	<ul style="list-style-type: none"> <li>(1) The control chart helps one understand the capabilities of the process.</li> <li>(2) The chart can prevent tampering with processes that are under statistical control.</li> <li>(3) The chart monitors the effects of process changes that are aimed at improvement.</li> <li>(4) Control charts can be used without extensive knowledge of statistics.</li> </ul>	<ul style="list-style-type: none"> <li>(1) The control chart tells only if the process is in control.</li> <li>(2) The underlying causes are not determined.</li> </ul>
Bar chart	5.3	<ul style="list-style-type: none"> <li>(1) The bar chart tells its story at a glance.</li> <li>(2) It makes graphic comparisons of quantity easy to see.</li> </ul>	A bar chart is limited in the number of data categories that can be displayed at one time.
Time-line chart	5.4	<ul style="list-style-type: none"> <li>(1) The time-line chart shows a “moving picture” of fluctuations over time.</li> <li>(2) Defect rates can be plotted on time lines in order to identify trends.</li> </ul>	The time-line chart shows the direction of change but it gives no indication as to the reason for the change.
Stratification chart	5.5	The approach not only produces a priority ordering of the problems but also identifies an improvement strategy.	<ul style="list-style-type: none"> <li>(1) The correct stratification variables for resolving a problem are generally not known prior to data collection.</li> <li>(2) All potentially important stratification variables cannot be determined without planning.</li> </ul>
Pareto chart	5.6	<ul style="list-style-type: none"> <li>(1) The pareto chart helps to identify the few areas of concern that are most important.</li> <li>(2) The chart is useful in analyzing defect data.</li> </ul>	A poor pareto chart will result if the causes chosen to study are wrong. Some preplanning needs to be done before choosing categories.
Histograms	5.7	<ul style="list-style-type: none"> <li>(1) A histogram helps identify changes in a process as the data changes.</li> <li>(2) A histogram helps establish standards for a process.</li> </ul>	A histogram is not a good tool for computing process capability.

### 5.1.3 Procedures

As described in reference 5.2, a scatter diagram is prepared in the following manner:

- (1) Collect the two selected variables of each occurrence.
- (2) Draw the horizontal and vertical scales with equal length.
- (3) The dependent variable, the one that you can have an effect on, is assigned to the vertical (Y) axis. The independent variable is assigned to the horizontal (X) axis. Set the scale intervals and label.
- (4) Plot each data point.
- (5) A possible relationship can be determined by visual inspection of the graph.

### 5.1.4 Example

As adapted from reference 5.3, an aptitude test was given to 10 employees and the scores were then compared to the production levels of these employees over a certain time period. The scatter diagram, example shown in figure 5-1, would show if there were any relationship between the test scores and the production levels.

<u>Employee</u>	<u>Test Score</u>	<u>Production Level</u>
1	27	120
2	13	80
3	8	60
4	37	150
5	32	135
6	10	70
7	17	95
8	22	105
9	6	50
10	7	55

This plot shows that the higher test scores result in higher production levels.

### 5.1.5 Advantages

- (1) The general relationship between two variables can be determined at a glance.
- (2) The graph can help determine a possible cause of problems by looking at correlations.

### 5.1.6 Limitations

- (1) The choice of scale for the graph can distort the data, thus possibly giving the appearance of a correlation that is better or worse than reality.
- (2) The correlation does not prove a cause-and-effect relationship.

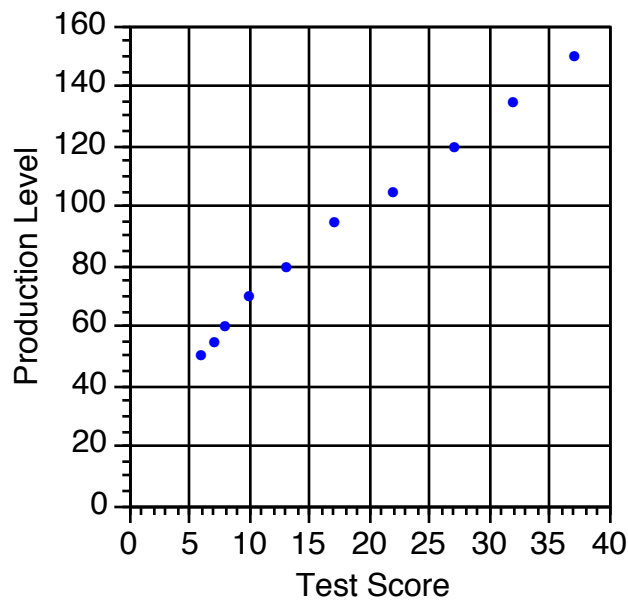

Figure 5-1. Scatter diagram example.

## 5.2 Control Chart

### 5.2.1 Description

A control chart monitors the performance of a process with frequent outputs. The chart shows a pictorial representation of an ongoing process and determines whether or not the process is performing within acceptable parameters. The control chart is based on four concepts:

- (1) All processes change with time.
- (2) Individual points of the process are unpredictable.
- (3) A stable process changes randomly, and groups of points from a stable process tend to fall within predictable bounds.
- (4) An unstable process does not change randomly, and when changes occur they are generally out of the range of normal operations.<sup>5.2</sup>

### 5.2.2 Application

The control chart technique is best performed in phase E. As described in reference 5.2, control charts are used to show the variation of several variables including average ( $\bar{X}$ ) and range ( $R$ ) as well as the number of defects ( $PN$ ), percent defective ( $P$ ), defects per variable unit ( $U$ ), and defects per fixed unit ( $C$ ).

The upper control limits (UCL) and lower control limits (LCL) should not be confused with specification limits. The control limits show the natural change of a process, such that points within the limits generally indicate normal and expected change. Points that are outside of the control limits reveal that something has occurred that requires special attention because the points are outside of the built-in

systematic cause of change in the process. One point that is outside of the control limits does not mean the process is out of control but it should be explained.

The control chart can be used continuously to determine whether the process remains within established control limits. As new points are added, the chart can be monitored for points that may fall outside of the limits and require causes to be identified.

Control charts are used in performing statistical process control (SPC) (sec. 7.14) and trend analysis (sec. 8.).

### 5.2.3 Procedures

As described in reference 5.2, a control chart (fig. 5-2) is constructed in the following manner:

- (1) Determine the control limits to show the expected change of the process.
- (2) Gather data.
- (3) Plot the data on the control chart to evaluate performance and identify the points outside of the control limits.
- (4) Determine why points are outside of the control limits.
- (5) Find ways to identify causes of problem points, reduce the normal variation, and improve the mean.

### 5.2.4 Example

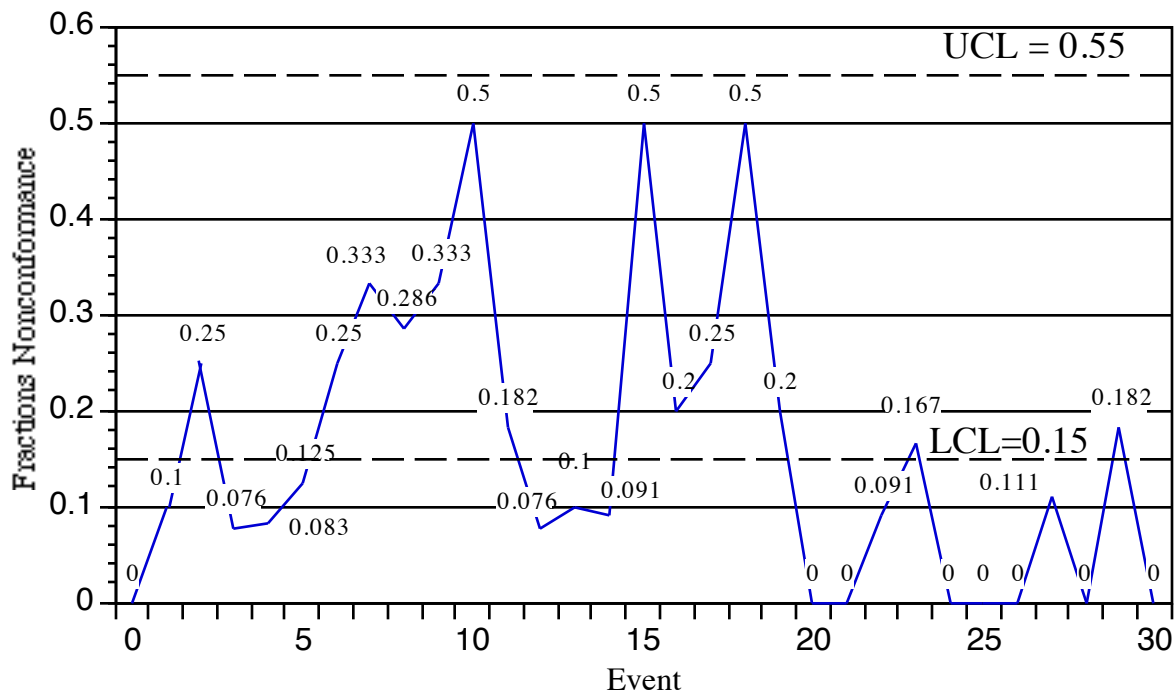

Figure 5-2. Control chart example.

### 5.2.5 Advantages

- (1) The control chart helps the analyst understand the capabilities of the process.
- (2) The control chart can prevent tampering with processes that are under statistical control.
- (3) The control chart monitors the effects of process changes that are aimed at improvement.
- (4) Control charts can be used without extensive knowledge of statistics.

### 5.2.6 Limitations

- (1) The control chart tells only if the process is in control.
- (2) The control chart does not indicate the underlying cause unless data on outside processes are included in the analysis.

## **5.3 Bar Chart**

### 5.3.1 Description

Bar charts show a comparison of quantities of data to help identify quantity changes. The quantities of data are depicted by the lengths of the bars that represent cost, percentage, or frequency of events. The bars may be horizontal or vertical.<sup>5.2</sup>

### 5.3.2 Application

Bar charts are one of the most common types of data display and this technique is typically performed in phase E. Differences and similarities between and among selected categories are emphasized by the heights of the columns. Bar charts can show double and triple bars to compare different time periods or different populations.

### 5.3.3 Procedures

As described in reference 5.2, a bar chart (fig. 5-3) is constructed in the following manner:

- (1) If necessary, raw data are entered on a checklist (sec. 7.8).
- (2) List the categories across the horizontal scale at the bottom.
- (3) Label the quantities on the vertical scale at the left. Make sure the scale is broad enough to include the highest and lowest value in each category.
- (4) Draw the bar according to the quantity of each category.
- (5) Give the bar chart a legend to identify different colors or patterns.

### 5.3.4 Example

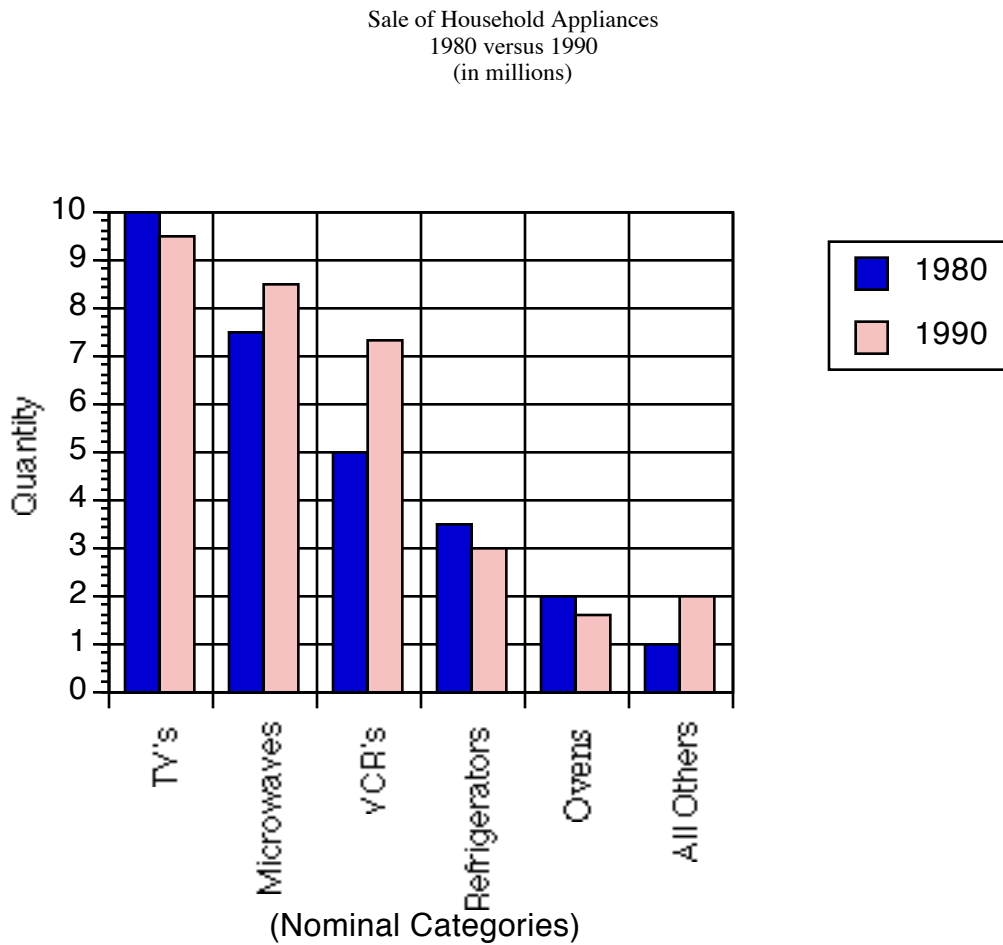

Figure 5-3. Bar chart example.

### 5.3.5 Advantages

- (1) The bar chart tells its story at a glance.
- (2) The bar chart makes graphic comparisons of quantity easy to see.

### 5.3.6 Limitations

A bar chart is somewhat limited in the number of data categories that can be displayed at one time.



## 5.4 Time-Line Chart

### 5.4.1 Description

The time-line chart is among the most common types of data displays. The chart graphically displays changes over a period of time.

### 5.4.2 Application

The time-line chart is a special case of XY plots where the independent variable is some time value. The chart connects data points with line segments. The line segments connecting the points on the chart give a clear picture of changes over time. The vertical scale is a quantity while the horizontal scale is divided into time intervals such as “hours,” “days,” and “weeks.”<sup>5.2</sup> This technique is best performed in phase E.

### 5.4.3 Procedures

As described in reference 5.2, a time-line chart (fig. 5-4) is prepared in the following manner:

- (1) Enter the raw data on a checklist (sec. 7.8).
- (2) Establish time intervals (usually hours, days, weeks, etc.) for the horizontal axis. The intervals should be evenly spaced and labeled.
- (3) Establish the quantities for the vertical axis and make them evenly spaced (e.g., 10, 20, 30, etc.) and label the axis.
- (4) Connect, with line segments, the quantities plotted for each successive interval.
- (5) If the points are difficult to read, add horizontal and vertical grids.
- (6) Title the chart to define the time period for which the data are displayed.

### 5.4.4 Example

A study was made comparing the average number of errors that were made per operator at different times of the day over a certain time period (fig. 5-4).

### 5.4.5 Advantages

- (1) The time-line shows a “moving picture” of fluctuations over time.
- (2) Defect rates can be plotted on time lines in order to identify trends.

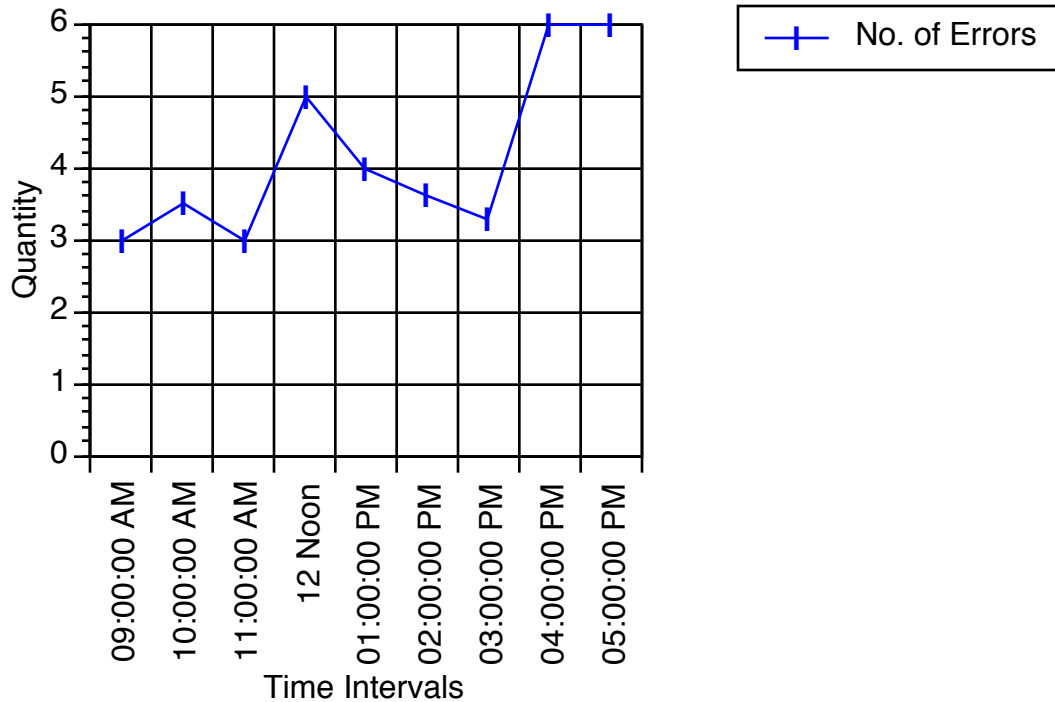

Figure 5-4. Time-line chart example.

#### 5.4.6 Limitations

The time-line chart shows the direction of change but it gives no indication as to the reason for the change.

### 5.5 Stratification Chart

#### 5.5.1 Description

The term “stratification,” derived from “stratum,” is used in data analysis. Stratification is done by sorting data into different groups that share a common characteristic. Some common stratification variables are shift, operator, and machine.

#### 5.5.2 Application

The stratification chart is best applied in phase E. Comparisons of different groups, units, or other types of strata can often lead to suggesting an improvement strategy. For example, a process is incurring a 10-percent defect rate with a particular product. You can stratify by vendor, lot, operator, shift, time, machine, etc. and compute a percent defective for each category (stratification variable).

The data can be depicted in graphic form for easy visual interpretation. Should the data not include a significant problem, select other stratification variables and collect more data. The graph may show that one category is producing a higher defect rate than others. This does not mean the “cause” of a problem has been found. What has been found is where the problem is occurring the most. The cause has yet to be determined.<sup>5.4</sup>

### 5.5.3 Procedures

As described in reference 5.4, the stratification process (fig. 5-5) is performed in the following manner:

- (1) Choose the stratification variables.
- (2) Gather data and record the potentially important stratification variables.
- (3) Graph the data using one of a number of different tools, such as bar chart (sec. 5.3), Pareto chart (sec. 5.6), and histograms (sec. 5.7).
- (4) Analyze the data on the chosen stratification variables and compare to each other.
- (5) Separate the possible problem areas into special and common cause problems.
- (6) If no conclusions are found, choose different stratification variables.
- (7) Determine the strategy to improve the problem.

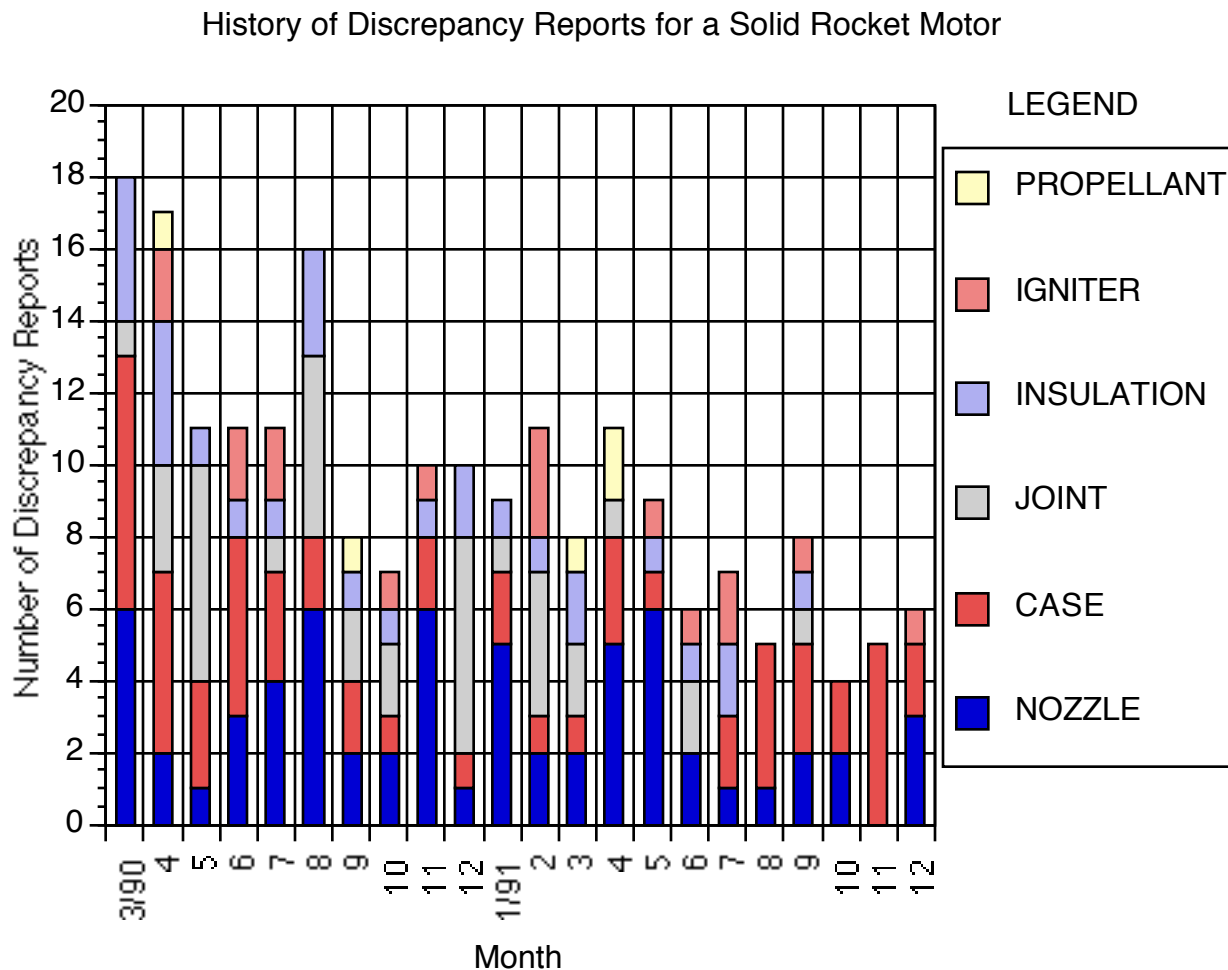

Figure 5-5. Stratification (histogram) chart example.

#### 5.5.4 Example

Shown in figure 5-5 is a histogram of discrepancy reports for a solid rocket motor (SRM), stratified by components.

#### 5.5.5 Advantages

The approach not only produces a priority ordering of the problems but also identifies areas for improvement.

#### 5.5.6 Limitations

- (1) The correct stratification variables for resolving a problem are generally not known prior to data collection.
- (2) All potentially important stratification variables cannot be determined without planning.

### **5.6 Pareto Chart**

#### 5.6.1 Description

When there is a need to know the relative importance of data or variables (problems, causes, or conditions), a Pareto chart is often used. This chart helps to highlight the few data or variables that may be vital. The Pareto chart also helps to identify which problems, causes, or conditions are the most important or most frequent so they can be addressed first.<sup>5.2</sup>

#### 5.6.2 Application

The Pareto chart can be used to examine the “how,” “what,” “when,” “where,” and “why” of a suspected problem cause. This technique is typically performed in phase E. The chart is an illustration of the data as of a specific time period. The data are arranged in descending order with the most important to the left. The Pareto chart is based on the “Pareto principle” which states that a few of the causes often account for most of the effects.<sup>5.5</sup> Pareto charts are used in performing problem trend analyses (sec. 8.2).

#### 5.6.3 Procedures

As described in reference 5.2, a Pareto chart (fig. 5-6) is created in the following manner:

- (1) Identify the most likely causes of a problem (take from the cause/effect diagram (sec. 7.2)).
- (2) Gather the data on causes; if necessary, use a checklist (sec. 7.8).
- (3) Summarize the numbers of observations and calculate the percentages of each cause.
- (4) Set the right vertical scale from zero to 100 percent.
- (5) Make the left vertical scale the same height as the right scale and set it from zero to the number of observations.

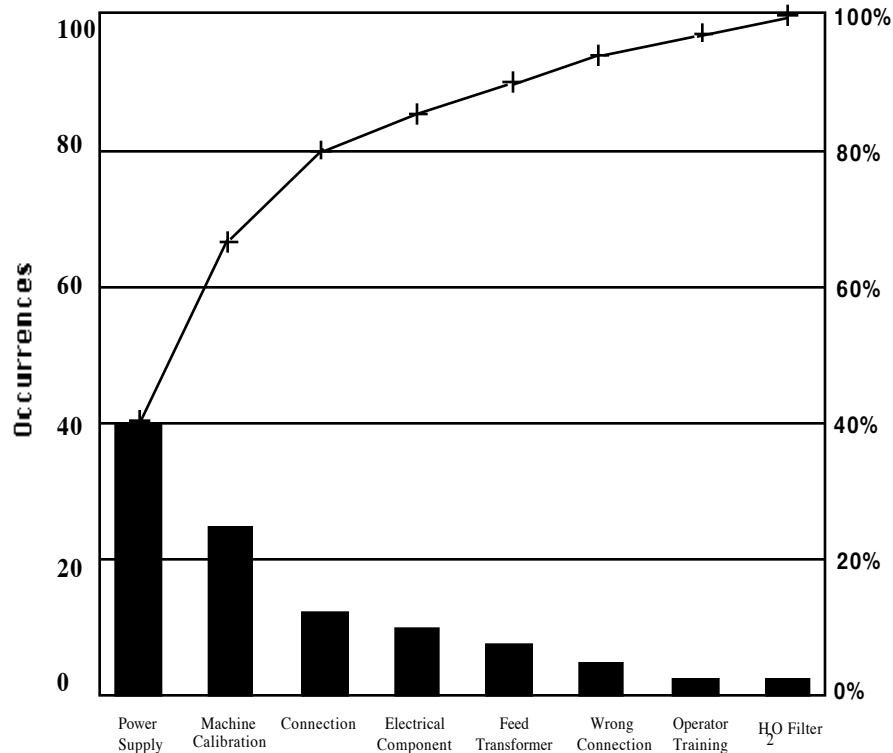

Figure 5-6. Pareto chart example.

- (6) The columns are drawn using the left scale.
- (7) The first point is plotted at the upper center of the first column.
- (8) Calculate and add together the percentages of cause one and two. The second point, corresponding to their sum, is plotted across from the right scale directly over the second column. The third point is found by adding the percentage of cause three to the total of one and two, and plot. The total of all columns added together should be 100 percent, and the last point is at the 100-percent point.
- (9) The plotted points are then joined with line segments.

The chart in figure 5-6 reveals the slope is more radical over the first two bars (power supply and machine calibration) and this means that the majority of the problems occur in these categories, i.e., areas to the left of the most radical slope are the most probable problem areas. This observation is even more obvious when the heights of the bars are examined.

### 5.6.5 Advantages

- (1) The Pareto chart helps to identify the few areas of concern that are most important.
- (2) The chart is useful in analyzing defect data.

### 5.6.6 Limitations

A poor Pareto chart will result if the causes chosen to study are wrong. Some preplanning needs to be done before choosing categories.

### 5.6.7 Bibliography

Cane, V.E.: "Defect Prevention, Use of Simple Statistical Tools." Ford Motor Company, Livonia, MI, 1989.

Hines, W.W., and Montgomery, D.C.: "Probability and Statistics in Engineering and Management Science." John Wiley, New York, 1986.

Wadsworth, S. and Godfrey: "Modern Methods for Quality Control and Improvement." John Wiley, New York, 1986.

## **5.7 Histograms**

### 5.7.1 Description

Histograms are bar charts that show a dispersion of data over a specified range. This spread of data makes presentations easier to interpret.<sup>5.1</sup>

### 5.7.2 Application

When data are plotted on histograms, many items tend to fall toward the center of the data distribution. Fewer items fall on either side of the center. The bars are proportional in height to the frequency of the group represented. Since group intervals are equal in size, the bars are of equal width.<sup>5.4</sup> The histogram is best applied in phase E.

### 5.7.3 Procedures

As described in reference 5.2, a histogram (fig. 5-7) is constructed in the following manner:

- (1) Gather the data to be plotted and count the total number of data points.
- (2) Find the range of the data by subtracting the smallest data point from the largest.
- (3) The number of data bars in the graph should be limited to between 6 and 12. The width of each bar is determined by dividing the range of data by the selected number of bars.
- (4) Scale the groups of data on the horizontal axis.

- (5) Scale the frequency of occurrence or the numbers on the vertical scale.
- (6) Plot the frequency of occurrence of the numbers in ascending order.
- (7) Draw the height of each bar to show the number or frequency of the group interval using the scale on the vertical axis. Each bar, including all data points, is the same width.

#### 5.7.4 Example

The chart in figure 5-7 displays a typical histogram.

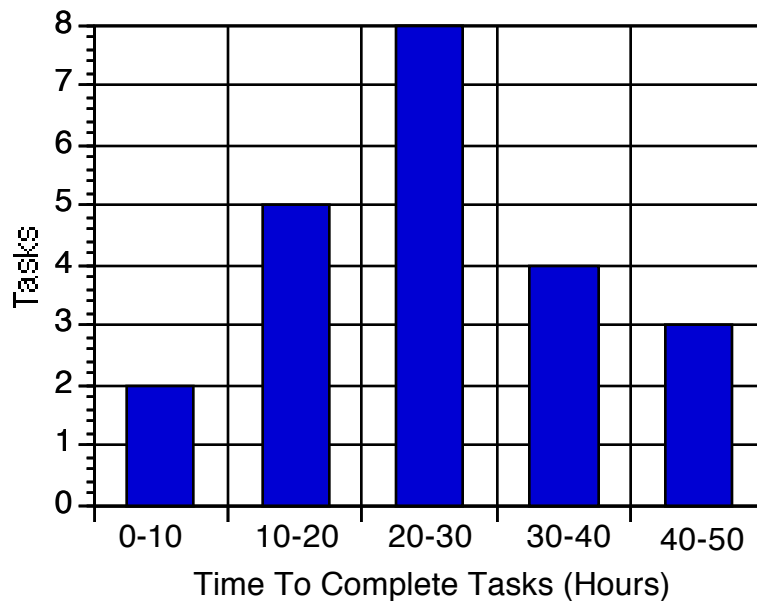

Figure 5-7. Histogram example.

#### 5.7.5 Advantages

- (1) A histogram helps identify changes in a process as the data changes.
- (2) A histogram helps establish standards for a process.

#### 5.7.6 Limitations

A histogram is not a good tool for computing process capability.

## REFERENCES

- 5.1 Brocka, B. and Brocka, M.S.: "Quality Management, Implementing the Best Ideas of the Masters." Business One Irwin, Homewood, IL 60430.
- 5.2 Hunt, V.D.: "Quality in America, How to Implement a Competitive Quality Program." HD62.15.H86, Business One Irwin, Homewood, IL 60430, 1992.
- 5.3 Lyonnet, P.: "Tools of Total Quality, An Introduction to Statistical Process Control." Chapman & Hall, 1991.
- 5.4 Cane, V.E.: "Defect Prevention, Use of Simple Statistical Tools." Ford Motor Company, Livonia, MI, 1989.
- 5.5 "Total Quality Management, A Guide for Implementation." DOD 5000.51-G (Draft), February 15, 1989.



## 6. STATISTICAL TOOLS AND METHODOLOGIES

There are numerous, excellent and highly detailed texts on the appropriate use of statistical techniques. While this section lists and briefly discusses some of the available tools, the novice statistician is cautioned to read and utilize standard, handbook references when using these techniques in problem solving. Use solely of this text might well result in misuse and error. This toolbox does provide a suitable knowledge of the existence of these tools and references for their appropriate application.

In this section, the following typical statistical processes are discussed: “student- $t$ ” ( $t$  test) analysis, analysis of variance (ANOVA), correlation analysis, factorial analysis, confidence analysis, regression analysis, and response surface methodology.

In many of these analyses, a comparison of sample statistics and population statistics will be made. Here, it is assumed that population statistics would be obtained if an infinite number of specimens could be measured, or if the solution to a function for the probability distribution of points were available. Sample statistics are made from actual measurements of a sample with a finite number of specimens. When only sample statistics are available (as is usually the case in engineering applications), there is a finite probability that they are “close” to the population statistics.<sup>6.1</sup>

A summary of the advantages and limitations of each tool or methodology discussed in this section is presented in table 6-1.

### 6.1 “Student- $t$ ” Analysis

#### 6.1.1 Description

As described in reference 6.1, the “student- $t$ ” compares the sample statistic “ $t$ ,” which is based on the sample mean and standard deviation, to the  $t$ -distribution for the same sample size and a desired significance (probability of error). The  $t$ -distribution is similar to the normal distribution in that with an infinite sample size, the  $t$ -distribution is equivalent to the standard normal distribution. At sample sizes lower than infinity, the  $t$ -distribution becomes “lower and flatter” than the normal distribution. The output of the  $t$ -distribution chart is the probability ( $\alpha$ ) that  $t$  exceeds a certain  $t_\alpha$  on the ordinate of the  $t$ -distribution chart. However, usually the probability is chosen and  $t_\alpha$  is sought; a  $t$ -distribution table is usually used to find  $t_\alpha$ .

The  $t$ -distribution was described in 1908 by W.S. Gosset under the pen name “student,” thus the name “student- $t$ ” analysis.

#### 6.1.2 Application

“Student- $t$ ” analyses, as described in reference 6.2, are used when sample sizes are low for the following functions:

- (1) Determine if a sample mean is equivalent to a population mean within a given probability of error.
- (2) Determine if two sample means are equivalent to each other within a given probability of error.

This technique is typically applied in phase D but may also be performed in phase C or E.

Table 6-1. Statistical tools and methodologies.

Tool or Methodology	Section	Advantages	Limitations
“Student- <i>t</i> ” analysis	6.1	The procedure is relatively simple to apply.	The parent distribution must be reasonably close to a normal distribution.
ANOVA	6.2	Sources of variation can be found, random variation isolated, or any chosen source of variability isolated.	The processes are time-consuming and often approximate.
Correlation analysis	6.3	The analysis is quite simple.	A straight-line relationship is assumed.
Factorial analysis	6.4	Sources of variation can be found, random variation isolated, or any chosen source of variability isolated. Also, interactions between variables can be isolated, and large numbers of variables can be solved.	The processes in factorial analysis are more time-consuming than the analysis of variance. A full factorial analysis does not solve for exponential or polynomial effects. The fractional factorial analysis does not solve for all effects and higher order effects separately.
Confidence/reliability determination and analysis	6.5	This analysis can give a realistic probability of whether or not a process may yield a value which is above or below a requirement.	A sample statistic must be known or assumed, such as the population standard deviation, before an analysis can be performed.
Regression analysis	6.6	A mathematical relationship can be determined, by hand or computer, when the relationship is not obvious by inspection.	If the data are discrete (e.g., integer data), the actual line generated will only approximate the actual relationship.
Response surface methodology	6.7	A mathematical relationship can be determined, by hand or computer, when the relationship is not obvious by inspection.	If the data are discrete (e.g., integer data), the actual line generated will only approximate the actual relationship.

### 6.1.3 Procedures

The use of a  $t$ -test for determining if a sample mean is equal to a chosen population mean will be shown here.

- (1) Determine the target mean and significance level desired.
- (2) Develop null and alternate hypotheses for the problem being investigated. If it is desired to prove that the sample mean is on one particular side of the population mean, the null hypothesis is that the sample and population mean are equal. The alternate hypothesis is that the sample mean is on the particular side of the population mean. If it is desired to prove that the sample mean is not on either side of the population mean, the null hypothesis would be the same, but the two alternate hypotheses would be that the sample mean is above or below the population mean. This latter situation would use a “two-tailed” analysis.
- (3) Determine the mean and standard deviation of the sample.
- (4) Determine the  $t$  value using equation (6.1).

$$t = \frac{\text{sample mean} - \text{target mean}}{\text{sample } \sigma / (n)^{1/2}} \quad (6.1)$$

- (5) Compare  $t$  with  $t_\alpha$  for the desired significance and degrees-of-freedom (DOF) ( $n-1$ ).

If  $t$  is greater than  $t_\alpha$ , the null hypothesis is disproved, i.e., it cannot be assumed with the chosen confidence that the sample mean is equivalent to the target mean. For a two-tailed analysis, if  $t$  is greater than  $t_{(\alpha/2)}$  (or  $t$  is less than  $-t_{(\alpha/2)}$ ), the null hypothesis is disproved.<sup>6.1</sup>

### 6.1.4 Example

Pull tests of a propellant sample yielded the following strains before failure: 29, 31, 35, 34, and 36 percent. The nominal strain capability is 34 percent. Determine with a 0.10 significance, if the propellant batch is representative of the nominal propellant. Since the mean of the propellant batch could be =, >, or <34 percent, a two-tailed analysis will be done. Thus,  $\alpha/2$  will be used (0.05 significance). The null hypothesis will be a strain capability equal to 34 percent.

The sample mean is 33 and the sample standard deviation is 2.915. Substituting into equation (6.1),  $t = 0.1539$ . From the  $t$ -distribution table for 4 DOF,  $t_\alpha = 2.134$ .

If  $H_o$  had been rejected, it could be stated that there was only one chance in ten that the null hypothesis was rejected when it should not have been. This is referred to as a type I error.

If  $H_o$  were not rejected, it could be stated that the null hypothesis could not be rejected at the 0.10 level of significance unless the probability of a type II error is determined. The determination of the probability of a type II error is complicated and many texts consider it beyond their scope.

### 6.1.5 Advantages

The procedure is relatively simple to apply.

### 6.1.6 Limitations

The distribution of the parent population must be reasonably close to a normal distribution.

### 6.1.7 Bibliography

Crow, E.L., Davis, F.A. and Maxfield, M.W.: "Statistics Manual." NAVORD Report 3369, NOTS 948.

Handbook 91, "Experimental Statistics." U.S. Department of Commerce, National Bureau of Standards.

Mendenhall, W.: "Introduction to Probability and Statistics." Fourth edition, Wadsworth Publishing Company, Belmont, CA 94002, 1975.

## 6.2 Analysis of Variance

### 6.2.1 Description

ANOVA is a technique used in design of experiments (sec. 5.5) to compare sample statistics, to determine if the variation of the mean and variance between two or more populations are attributable to sources other than random variation.<sup>6.1</sup>

### 6.2.2 Application

The ANOVA technique is typically performed in phase D but may also be performed in phase C or E.

Some of the uses for analysis of variance are:

- (1) Determining if two or more processes are producing products that are consistent with each other.
- (2) Determine which two or more processes are different if a difference in processes is detected.
- (3) Eliminate one source of variation to determine the effect of the others.
- (4) Determining the significance of each factor.

### 6.2.3 Procedures

As described in reference 6.1, to determine if two or more samples have different sample statistics, the following methods can be used to determine if the within-sample variation is greater than the sample-to-sample variation. If only one source of variation is being investigated, a one way classification is used. A factor  $F$  (equation (6.2)) is compared to  $F_{\alpha}$ , a value that is related to the total DOF, based on the number of samples ( $k$ ) and the sample size ( $n$ ).

$$F = \frac{\text{between-sample variance}}{\text{mean of within-sample variance}} \quad (6.2)$$

The DOF of the number of samples is  $k-1$ , and the DOF of the sample size is  $n-1$ . The total DOF is  $k*(n-1)$ . If  $F$  exceeds  $F_{\alpha}$ , then a difference exists between the samples that is not only due to random variation.  $F_{\alpha}$  is found from an  $F$  distribution table.

Rather than determining sample statistics for each sample, approximation formulas that use sums and averages of squares, can be used.

$$F = \frac{SS(bs)/(k-1)}{SSE/k(n-1)}, \quad (6.3)$$

where  $SS(bs)$  is the sum of squares (between-sample) and  $SSE$  is the sum of squares error. The  $SSE$  is determined from the sum of squares total ( $SST$ ) and  $SS(bs)$  by the formula

$$SSE = SST - SS(bs).$$

$SST$  and  $SS(bs)$  can be found using the formulas

$$SST = \sum (y_{ij})^2 - C, \quad SS(bs) = \sum (T_i)^2/n - C,$$

and

$$C = T^2/(k*n)$$

where  $y_{ij}$  = each data point,  $T$  = total of all data points, and  $T_i$  = total for each sample.

If two sources of variation are being investigated, a two-way classification is used. Data can be arranged in blocks representing one source of variation, and one data point from each sample representing the other source of variation is put into each block (see example below). If two sources are being investigated, the following approximation equations can be used:

$$F(bs1) = \frac{MS(bs1)}{MSE} = \frac{SS(bs1)/a-1}{SSE/K(a-1)(b-1)} \quad (6.4)$$

and

$$F(bs2) = \frac{MS(bs2)}{MSE} = \frac{SS(bs2)/b-1}{SSE/K(a-1)(b-1)} \quad (6.5)$$

where

$$SSE = SST - SS(bs1) - SS(bs2);$$

$$SST = \sum (y_{ij})^2 - C;$$

MS = Mean square

MSE = Mean square error

$$SS(bs1) = \sum (T_i)^2/b - C;$$

$$SS(bs2) = \sum (T_j)^2/a - C; \text{ and}$$

$$C = T^2/(k*n),$$

where  $a$  = the number of samples of one source of variation and  $b$  = the number of samples of the other source of variation.

Other methods exist to isolate more sources of variability simultaneously. The latin square method eliminates three sources, and the Greco-Latin method eliminates four sources. These methods must use  $n^2$  observations.

Analysis of covariance is a similar technique used when conditions (such as environmental) change. The effect of this change is accounted for by using regression. This involves partitioning a total sum of products rather than squares.

#### 6.2.4 Example

In the following hypothetical example, the effect of two parameters on the variability of strain capability of a solid propellant will be investigated. The use of three lots of polymer (parameter A) and two lots of curative (parameter B) will be investigated. Six batches of propellant are mixed and tested with the following average results:

<u>Polymer</u>	<u>Curative</u>	<u>Percent Strain</u>
1	1	30
1	2	34
2	1	32
2	2	36
3	1	31
3	2	33

The following table is arranged with parameter A set up in columns and parameter B set up in rows:

	<u>Curative Lot 1</u>	<u>Curative Lot 2</u>	<u>Total for Polymer</u>
Polymer lot 1	30	34	64
Polymer lot 2	32	36	68
Polymer lot 3	31	33	64
Total for curative	93	103	196

here

$$C = (196)^2/6 = 6402.67,$$

$$SST = 30^2 + 34^2 + 32^2 + 36^2 + 31^2 + 33^2 - 6402.67 = 6426 - 6402.67 = 23.33,$$

$$SS(bs1) = (64^2 + 68^2 + 64^2)/2 - 6402.67 = 6408 - 6402.67 = 5.33,$$

$$SS(bs2) = (93^2 + 103^2)/3 - 6402.67 = 16.67,$$

$$MS(bs1) = 5.33/2 = 2.67,$$

$$MS(bs2) = 16.67/1 = 16.67,$$

$$MSE = 1.33/((3-1)(2-1)) = 0.67,$$

$$F(sb1) = 2.67/0.67 = 4.0, \text{ and}$$

$$F(sb2) = 16.67/0.67 = 24.88.$$

Note that  $a = 3$  is the number of sources of variation of parameter A (polymer), and  $b = 2$  is the number of sources of variation of parameter B. Since  $F(sb1)$  is less than  $F_{\alpha}$  for a 0.05 significance ( $F_{\alpha} = 5.14$ ), polymer has no effect on strain capability. Since  $F(sb1)$  for a 0.05 significance is greater than 5.99, strain capability is affected by the curative lot.

### 6.2.5 Advantages

Sources of variation can be found, random variation isolated, or any chosen source of variability isolated.

### 6.2.6 Limitations

The processes are time-consuming and often approximate.

## 6.3 Correlation Analysis

### 6.3.1 Description

Correlation analysis measures the strength of a linear relationship between two sets of data.<sup>6.3</sup>

### 6.3.2 Application

Correlation analysis can be used to determine if a relationship exists between two independent sets of variables. This technique is best performed in phase D but may also be performed in phase C or E.

### 6.3.3 Procedures

The procedures, as found in reference 6.3, for determining if two sets of data are linearly related is as follows:

- (1) Determine the mean of each set of data.
- (2) Determine the  $r$  value of the two sets of data using the following equation:

$$r = \frac{\Sigma(x_i - \bar{x})(y_i - \bar{y})}{\Sigma((x_i - \bar{x})^2)^{1/2} \Sigma((y_i - \bar{y})^2)^{1/2}} \quad (6.6)$$

where  $\bar{x}$  and  $\bar{y}$  are the means of the first and second set of data respectively. The value of  $r$  will be between  $-1$  and  $1$ . If  $r$  is close to  $0$ , then no correlation is implied; if  $r$  is close to  $1$  (or  $-1$ ) then a high degree of correlation is implied.

- (3) Determine the significance of the  $r$  value by using the following equation:

$$z = \frac{(n-3)}{2} 1n \frac{(1+r)}{(1-r)} \quad (6.7)$$

- (4) Look up the  $z$  value in a standard normal distribution table to determine the probability of having a correlation.

#### 6.3.4 Example

The following hypothetical sets of measurements were taken: 5.4, 6.2, 6.5, 7, and 7.5; and 2.3, 2.1, 2, 1.8, and 1.6. The mean of the two sets are 6.52 and 1.96, respectively. The deviations, products, and squares of the deviations from the means are shown in the following.

$x$	$y$	$dx$	$dy$	$dx * dy$	$dx^2$	$dy^2$
5.4	2.3	-1.12	0.34	-0.3808	1.25	0.1156
6.2	2.1	-0.32	0.14	-0.0448	0.1024	0.0196
6.5	2.0	-0.02	0.04	-0.0008	0.0004	0.0016
7.0	1.8	0.48	-0.16	-0.0768	0.2304	0.256
7.5	1.6	0.98	-0.36	-0.3528	0.9604	0.1296
summations				-0.856	2.548	0.292

Using equation (6.6), the  $r$  value is 0.992. Using this value for  $n = 5$ ,  $z$  is  $-3.938$ , thus there is less than a 0.01 percent chance of these two data sets not being related.

#### 6.3.5 Advantages

This analysis is simple to apply.

#### 6.3.6 Limitations

A straight-line relationship is assumed.

## 6.4 Factorial Analysis

### 6.4.1 Description

There are three types of factorial analysis described in this section—factorial analysis, full factorial analysis, and fractional factorial analysis. Factorial analysis is similar to ANOVA in that the analysis is based on sums of squares, however, factorial analysis further subdivides the treatment of sums of squares into components and can show interaction effects between parameters.<sup>6.1</sup>

### 6.4.2 Application

Factorial analysis is used for applications similar to those for which ANOVA is used, except that factorial analysis deals with levels of variables. Factorial analysis is used with a small number of variables (e.g., two to four). Full factorial analysis is performed for more variables, but only at two levels for each variable. Fractional factorial analysis is used when so many variables are being investigated that experimenting with them is unfeasible. For example, if five variables are being investigated,  $2^5$  or 32 experiments would have to be performed. For six variables, the number would be 64, and this is without replication. Thus, fractional factorial analysis is often economically necessary.<sup>6.1</sup> This technique is typically performed in phase C but may also be performed in phase D or E.



### 6.4.3 Procedures

As described in reference 6.1, factorial analysis is performed the same as analysis of variance except that an analysis of variance is performed for each variable against each other variable.

The procedure for performing a full factorial analysis will be discussed here. With factorial analysis,  $2^n$  factorial experiments will be performed, and to account for experimental variability,  $r$  replications will be performed. Here  $n$  will be the number of factors rather than the sample size (which is effectively two). With factorial analysis, certain computational shortcuts can be applied when only two levels of each variable are used, assuming straight line relationships. The following is the procedure for using the factorial analysis where  $n = 3$ .

- (1) Arrange the factors and magnitudes in a table such as the following:

Table 6-2. Factorial analysis factors and magnitudes.

<i>A0,B0,C0</i>	<i>M1</i>	<i>M2</i>	<i>M3</i>	total <i>A0,B0,C0</i>
<i>A1,B0,C0</i>	<i>M1</i>	<i>M2</i>	<i>M3</i>	total <i>A1,B0,C0</i>
<i>A0,B1,C0</i>	<i>M1</i>	<i>M2</i>	<i>M3</i>	total <i>A0,B1,C0</i>
<i>A1,B1,C0</i>	<i>M1</i>	<i>M2</i>	<i>M3</i>	total <i>A1,B1,C0</i>
<i>A0,B0,C1</i>	<i>M1</i>	<i>M2</i>	<i>M3</i>	total <i>A0,B0,C1</i>
<i>A1,B0,C1</i>	<i>M1</i>	<i>M2</i>	<i>M3</i>	total <i>A1,B0,C1</i>
<i>A0,B1,C1</i>	<i>M1</i>	<i>M2</i>	<i>M3</i>	total <i>A0,B1,C1</i>
<i>A1,B1,C1</i>	<i>M1</i>	<i>M2</i>	<i>M3</i>	total <i>A1,B1,C1</i>

etc. where the first column represents the experimental conditions and  $M1$ ,  $M2$ , and  $M3$  represent the resulting magnitudes after the experiment for replication 1, 2, and 3. The last column is the total of all replications of experiments for each experimental condition.

- (2) Obtain a table of effects totals by removing the middle columns in the above table.
- (3) Apply the method of Yates to this table as follows:
  - a. Add  $n$  (3) columns in the place of the middle columns and three columns to the right side of the table (table 6-3).
  - b. Add the first two totals in the totals column to get the first element in column 1. Add the third and fourth totals in the totals column to get the second element in column 1. Continue in a like manner to get the third and fourth elements in column 1. Obtain the fifth through eighth elements in column 1 the same way except that the totals are subtracted (first value subtracted from the second). Column 2 is constructed the same way from column 1 as column 1 was constructed from the totals column. Column 3 is constructed the same way from column 2. Column 3 is the effect totals as in analysis of variation. The notation in column  $n$  (3) and the sum of squares column is shortened; 2:1 means the first element of column 2.
  - c. Add a row for the error sum of squares and error mean square, determined as in ANOVA.

Table 6-3. Factorial analysis example.

	Exp. Condition	Totals from Above	1	2	3	Sum of Squares	Mean of Squares	F
1	A0,B0,C0	t1	t1 + t2	(t1 + t2) + (t3 + t4)	2:1 + 2:2	3:1/(r2 <sup>n</sup> )	SS1/DOF	MS1/SME
2	A1,B0,C0	t2	t3 + t4	(t5 + t6) + (t7 + t8)	2:3 + 2:4	3:1/(r2 <sup>n</sup> )	SS2/DOF	MS2/SME
3	A0,B1,C0	t3	t5 + t6	(t2 - t1) + (t4 - t3)	2:5 + 2:6	3:1/(r2 <sup>n</sup> )	SS3/DOF	MS3/SME
4	A1,B1,C0	t4	t7 + t8	(t6 - t5) + (t8 - t7)	2:7 + 2:8	3:1/(r2 <sup>n</sup> )	SS4/DOF	MS4/SME
5	A0,B0,C1	t5	t2 - t1	(t3 + t4) - (t1 + t2)	2:2 - 2:1	3:1/(r2 <sup>n</sup> )	SS5/DOF	MS5/SME
6	A1,B0,C1	t6	t4 - t3	(t7 + t8) - (t5 + t6)	2:4 - 2:3	3:1/(r2 <sup>n</sup> )	SS6/DOF	MS6/SME
7	A0,B1,C1	t7	t6 - t5	(t4 - t3) - (t2 - t1)	2:6 - 2:5	3:1/(r2 <sup>n</sup> )	SS7/DOF	MS7/SME
8	A1,B1,C1	t8	t8 - t7	(t8 - t7) - (t6 - t5)	2:8 - 2:7	3:1/(r2 <sup>n</sup> )	SS8/DOF	MS8/SME
	summation					SSE	SME	

To find:

$$2:1 + 2:2 = (t1 + t2) + (t3 + t4) + (t5 + t6) + (t7 + t8)$$

$$2:3 + 2:4 = (t2 - t1) + (t4 - t3) + (t6 - t5) + (t8 - t7)$$

$$2:2 - 2:1 = (t5 + t6) + (t7 + t8) - (t1 + t2) + (t3 + t4)$$

$$2:4 - 2:3 = (t6 - t5) + (t8 - t7) - (t2 - t1) + (t4 - t3)$$

- (4) The sum of squares column is generated by dividing the square of each adjacent element in column 3 by  $r * 2^n$ .
- (5) The mean of squares column is generated by dividing each adjacent element in the sum of squares column by its respective DOF. The DOF will be 1 for each effect, but will be  $n-1$  for the error row.
- (6) Obtain each  $F$  by dividing each mean square by the error mean square.
- (7) Compare each  $F$  to  $F_{\alpha}$  for  $n-1$ , DOF. If any  $F$  exceeds  $F_{\alpha}$ , that effect is significant.

A fractional factorial analysis is performed the same way as the full factorial analysis except the analysis is split into fractions of  $(1/2)^P$ . Thus, if a five variable investigation (32 experiments) is split into  $1/4$ , the number of experiments will be  $2^{n-P}$  (eight) experiments.

#### 6.4.4 Example

The following are the results of a hypothetical experiment to determine if mix time, mix speed, and mix vacuum affects the burn rate of a propellant. Two levels of each parameter were tested as follows:

Effect	Parameter	Low (0)	High (1)
A	mix time	2 hr	3 hr
B	mix speed	1 rps	2 rps
C	vacuum	no vacuum	0.2 atm

Each effect was assigned a high and low level (e.g., 1 rps was assigned as low, 2 rps was assigned as high). The high and low levels are designated as 0 and 1, respectively. Each experimental condition was repeated three times with the following results:

<u>Exp. Condition</u>	<u>Rep 1</u>	<u>Rep 2</u>	<u>Rep 3</u>	<u>Total</u>
A0 B0 C0	0.47	0.47	0.52	1.46
A1 B0 C0	0.46	0.46	0.51	1.43
A0 B1 C0	0.47	0.48	0.52	1.47
A1 B1 C0	0.48	0.50	0.50	1.48
A0 B0 C1	0.51	0.50	0.54	1.55
A1 B0 C1	0.49	0.52	0.54	1.55
A0 B1 C1	0.52	0.51	0.55	1.58
A1 B1 C1	0.50	0.52	0.54	1.56

The table is repeated with the replication columns deleted and replaced with the application of three columns for the Method of Yates. Three additional columns are added, one for the sum of squares, one for the mean square, and one for the  $F$  value for each effect.

<u>Exp. Condition</u>	<u>Total</u>	<u>1</u>	<u>2</u>	<u>3</u>	<u>Sum of Squares</u>	<u>Mean of Squares</u>	<u>DOF</u>	<u>F</u>
A0 B0 C0	1.46	2.89	5.84	12.08	6.0803	6.0803	1	
A1 B0 C0	1.43	2.95	6.24	-0.04	0.000067	0.000067	1	0.2977
A0 B1 C0	1.47	3.10	-0.02	0.10	0.000417	0.000417	1	1.8616
A1 B1 C0	1.48	3.14	-0.02	0.02	0.000017	0.000017	1	0.0745
A0 B0 C1	1.55	-0.03	0.06	0.04	0.00667	0.00667	1	29.77
A1 B0 C1	1.55	0.01	0.04	0	0	0	1	0
A0 B1 C1	1.58	0	0.04	-0.02	0.000017	0.000017	1	0.0745
A1 B1 C1	1.56	-0.02	-0.02	-0.06	0.00015	0.00015	1	0.669
Replicates	SSR	SMR			0.00723	0.003615	2	16.138
error	SSE	SME			0.00157	0.000224	7	

The correction term ( $C$ ) is as follows:

$$C = \frac{(\text{Sum of totals})^2}{(\text{Number of effects})(\text{Number of totals})} \quad (6.8)$$

The SST is as follows:

$$\text{SST} = \text{Sum of each individual replication squared} - C. \quad (6.9)$$

The sum of squares treatment (SSTr) is as follows:

$$\text{SSTr} = [(\text{Sum of each individual total squared})/(\text{Number of effects})] - C. \quad (6.10)$$

The sum of squares replication (SSR) is as follows:

$$SSR = [(\text{Sum of vertical replication total squared})/\text{Number of rows}] - C. \quad (6.11)$$

The sum of squares error (SSE) is as follows:

$$SSE = SST - SStr - SSR. \quad (6.12)$$

The sum of mean replicate (SMR) is as follows:

$$SMR = SSR/DOF. \quad (6.13)$$

The sum of mean error (SME) is as follows:

$$SME = SSE/DOF. \quad (6.14)$$

$F_\alpha$  for a 0.05 confidence is 5.59, therefore effect  $C$  (vacuum) and replication have a significant effect on the burn rate. (The third batch of propellant may have been different for another reason such as contamination.) Note that since no values of  $F$  are greater than  $F_\alpha$  for any conditions where two or more effects are 1, then no interactions have a significant effect on burn rate. (For example, if the fourth line had an  $F$  greater than  $F_\alpha$ , then the interaction of mix time and mix speed would have a significant interaction).

#### 6.4.5 Advantages

Sources of variation can be found, random variation isolated, or any chosen source of variability isolated. Also, interactions between variables can be isolated, and larger numbers of variables can be solved for.

#### 6.4.6 Limitations

The processes in factor analysis are more time-consuming than the analysis of variance. A full factorial analysis does not solve for exponential or polynomial effects. The fractional factorial analysis does not solve for all effects and higher order effects separately.

### 6.5 Confidence/Reliability Determination and Analysis

#### 6.5.1 Description

Confidence analysis compares sample values, means, or standard deviations with population standard deviations to obtain a confidence interval, with a chosen significance.

#### 6.5.2 Application

Confidence analysis is used to determine the interval of values that a data point could take, with a chosen probability of being within that interval. Confidence analysis can be used with individual points, means, standard deviations, regression lines, or reliability measurements such as mean time between failures.<sup>6.1</sup> This technique is typically performed in phase C or E.

### 6.5.3 Procedures

As described in reference 6.1, the procedures for determining the confidence interval for the population mean, given a sample mean, will be discussed here.

- (1) Choose a confidence ( $\alpha$ ) level and obtain the  $\alpha/2$  term by dividing the confidence level by 2.
- (2) Determine, from past experience (or by adjusting the sample standard deviation), the population standard deviation.
- (3) Obtain the  $z_{(\alpha/2)}$  value by looking up the  $z$  value for  $\alpha/2$  in a normal distribution table.
- (4) The values for either end of the confidence interval is given by the equation:

$$Int = m_s \pm z_{(\alpha/2)} * s_p / n^{1/2} \quad (6.15)$$

where  $Int$  is the low or high confidence interval value,  $m_s$  is the sample mean,  $s_p$  is the population standard deviation, and  $n$  is the sample size. For large  $n$ , the sample standard deviation can be used instead of the population standard deviation.

The confidence interval for the population standard deviation, given the sample standard deviation, is determined in the same way as above, except equation (6.16) is used.

$$Int = \frac{s_p}{1 \pm z_{(\alpha/2)} / s_s / (2 * n)^{1/2}} \quad (6.16)$$

where  $s_s$  is the sample standard deviation. For linear regression, the confidence for the equation of the line is:

$$Int = (a + bx_o) \pm t_{\alpha/2} * s_e * (1/n + n(x_o - m_s)^2 / S_{xx})^{1/2} \quad (6.17)$$

and for the  $y$  value:

$$Int = (a + bx_o) \pm t_{\alpha/2} * s_e * (1 + 1/n + n(x_o - m_s)^2 / S_{xx})^{1/2} \quad (6.18)$$

where

$$s_e^2 = 1 / (n - 2) \sum (y_i - (a + bxi))^2 = \frac{S_{xx} * S_{yy} - (S_{xy})^2}{n(n-2)S_{xx}}$$

where

$$S_{xx} = n * \sum x_i^2 - (\sum x_i)^2, S_{yy} = n * \sum y_i^2 - (\sum y_i)^2, \text{ and } S_{xy} = n * \sum x_i y_i - (\sum x_i) * (\sum Y_i) .$$

### 6.5.4 Example

Determine the confidence interval for insulation erosion at a station in the RSRM aft dome to determine if the associated compliance safety factor (CSF) may actually fall below the 1.0 minimum value, with a 95 percent confidence. The sample data for 18 flights (36 motors) is:

Erosion mean	1.112 in
Standard deviation	0.207 in (defined as known $s_p$ )
$n$	36

$\alpha/2$  is  $(1-0.95)/2 = 0.025$ , therefore the  $z_{(\alpha/2)}$  term is 1.96. Entering the above values into equation (6.15), the confidence interval is  $1.112 \pm 1.96 * 0.207/(36)^{1/2} =$  from 1.042 to 1.182 for erosion.

The safety factor is then calculated using the maximum erosion value and is:

$$\text{CSF} = \frac{\text{Min Ins } t}{\text{Erosion} + 3s_p + 0.1}$$

$$\text{CSF} = \frac{3.36}{1.182 + 3(0.207) + 0.1} = 1.766 .$$

So, in this instance the confidence interval is used to calculate a safety value that can be compared to a performance requirement.

### 6.5.5 Advantages

This analysis can give a realistic probability of whether or not a process may yield a value which is above or below a requirement.

### 6.5.6 Limitations

A sample statistic must be known or assumed, such as the population standard deviation, before an analysis can be performed.

## 6.6 Regression Analysis

### 6.6.1 Description

Regression analysis is a form of curve fitting to find a mathematical relationship for a group of data. There are typically two types of regression: regression and multiple regression. Typical types of relationships which are assumed for regression include linear (straight line), polynomial, and exponential. A goodness of fit test is often performed to see how well the generated relationship fits the data.<sup>6.3</sup>

The method of least squares is probably the most frequently used method of regression. The equation for the method of least squares is obtained by setting the derivative equal to zero of the equation for the sum of the vertical distance from each  $y$  value to the mean  $y$  value.

### 6.6.2 Application

Regression, as described in reference 6.1, is typically used for three purposes:

- (1) To find the mathematical relationship represented by a group of data points.
- (2) To determine if the magnitude of a measurement is increasing or decreasing with time or event.

Regression analysis is best applied in phase D but may also be applied in phase E. There are several methods of regression. Multiple regression will be discussed in section 6.7. The least squares method is a commonly used method of regression, and will be discussed here (assuming a straight-line relationship). The  $R^2$  indicates the percent variation in the dependent variable that can be explained by the independent variable.

### 6.6.3 Procedures

As described in reference 6.3, the use of the least squares method for finding the equation of a line of the form

$$y = a + bx, \quad (6.19)$$

is as follows:

- (1) Determine the mean of the  $x_i$  values ( $\bar{x}$ ) and  $y_i$  values ( $\bar{y}$ ).
- (2) Determine the deviation of each  $x_i$  and  $y_i$  value.
- (3) Determine the slope of the trend line by dividing the summation of the multiple of the deviations by the summation of the square of the  $x$  deviations (equation (6.19)).

$$b = \frac{\sum(x_i - \bar{x})(y_i - \bar{y})}{\sum(x_i - \bar{x})^2} \quad (6.20)$$

- (4) Determine the  $y$  intercept by subtracting the product of the slope and the mean  $x$  value from the mean  $y$  value (equation (6.20)).

$$a = \bar{y} - (b)\bar{x}. \quad (6.21)$$

The intercept and slope are used in equation (6.19) for a line representing the straight-line relationship. If the slope ( $b$ ) is negative, then a decreasing trend may be indicated.

The explanatory power can be determined by  $R^2$  as follows:

- (1) Determine  $y$  values for each  $x$  value using the line generated above.
- (2) Determine the deviation of each generated  $y$  value from the mean  $y$ .

- (3) Obtain the  $R^2$  value by dividing the sum of the square of the generated  $y$  deviations by the sum of the square of the actual  $y$  deviations (equation (6.21)).

$$R^2 = \frac{\Sigma(\text{gen } y_i - \bar{y})^2}{\Sigma(y_i - \bar{y})^2} \quad (6.22)$$

A good relationship is indicated by an  $R^2$  value close to 1.

#### 6.6.4 Example

As adapted from reference 6.3, assume the set of ordered pairs (1,4), (2,5), (3,6), (4,3), (5,5), (6,5), (7,4), (8,6), (9,4), and (10,5). The following table shows summations, squares, and products that go into the equations above:

$x$	$y$	$(dx)^2$	$(dy)^2$	$(dx)(dy)$	$y_g$	$dy_g^2$
1	4	20.25	0.49	3.15	4.56	0.0196
2	5	12.25	0.09	-1.05	4.59	0.0121
3	6	6.25	1.69	-3.25	4.62	0.0064
4	3	2.25	2.89	2.55	4.65	0.0025
5	5	0.25	0.09	-0.15	4.68	0.0004
6	5	0.25	0.09	0.15	4.71	0.0001
7	4	2.25	0.49	-1.05	4.75	0.0025
8	6	6.25	1.69	3.25	4.78	0.0064
9	4	12.25	0.49	-2.45	4.81	0.0121
10	5	20.25	0.09	1.35	4.84	0.0196
summation	55	82.5	8.1	2.50		0.0817

where  $dx = x_i - \bar{x}$ ,  $dy = y_i - \bar{y}$ ,  $y_g =$  generated points for each  $x$ , and  $dy_g = y_g - \bar{y}$ . Using these data, the mean  $x$  value is 5.5, the mean  $y$  value is 4.7, the slope ( $b$ ) is 0.0303, and the  $y$  intercept ( $a$ ) is 4.533. The equation for the line is  $y = 0.0303(x) + 4.533$ . No significant relationship is indicated for this example,  $R^2 = 0.0101$ . Figure 6-1 shows the points and the generated line for this data.

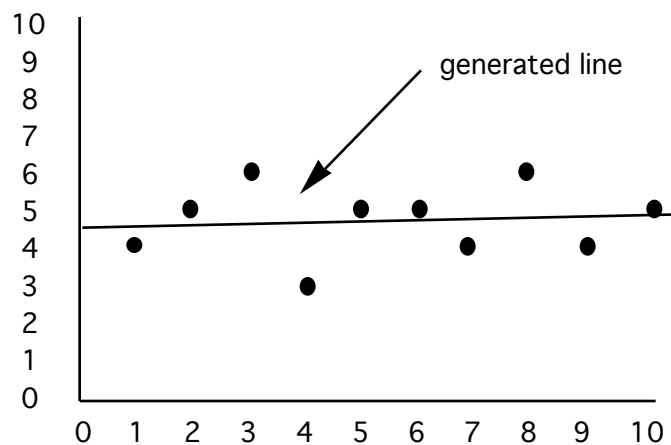

Figure 6-1. Line generated with least squares method.



### 6.6.5 Advantages

A mathematical relationship can be determined, by hand or computer, when the relationship is not obvious by inspection.

### 6.6.6 Limitations

If the data are discrete, e.g., integer data, the actual line generated will only approximate the actual relationship.

## 6.7 Response Surface Methodology

### 6.7.1 Description

Response surface methodology is a method for surface fitting, much like regression is a method for curve fitting. The surface can be a plane, using two independent variables and straight-line relationships, or it can be a more complex surface, using polynomial relationships. There are two typically used methods for response surface analysis—multiple regression and factorial experimentation. Factorial experimentation is discussed in section 6.4.<sup>6.1</sup>

### 6.7.2 Application

Response surface analysis is typically used for the following purposes:

- (1) To find the mathematical relationship represented by a group of data points.
- (2) To optimize independent variables for maximum or minimum results.

This methodology is best performed in phase D or E.

### 6.7.3 Procedures

As described in reference 6.3, the least squares method of multiple regression, assuming a straight-line relationship, will be shown here. The basic form of the equation for a plane surface is  $y = a + b_1x_1 + b_2x_2 + b_3x_3 + \dots + b_nx_n$ . This equation is minimized. After setting the derivative of the equation for the sum of the vertical distances or  $\sum (y_i - (a + b_1x_1 + b_2x_2 + b_3x_3 + \dots + b_nx_n))^2$  to zero, the equations for two independent variables are:

$$\begin{aligned}\sum y &= nb_0 + b_1 * \sum x_1 + b_2 * \sum x_2, \\ \sum (x_1 * y) &= b_0 * \sum x_1 + b_1 * \sum x_1^2 + b_2 * \sum (x_1 * x_2), \\ \sum (x_2 * y) &= b_0 * \sum x_2 + b_1 * \sum (x_1 * x_2) + b_2 * \sum x_2^2.\end{aligned}\tag{6.23}$$

These equations are solved simultaneously for  $b_0$ ,  $b_1$ , and  $b_2$ .

Often, if the numbers are equally spaced, a set of numbers is coded. For example, the numbers are substituted by assuming a smaller whole number for each original number. This practice makes solving for the coefficients much easier with very little cost in accuracy.

#### 6.7.4 Example

In the following hypothetical example, as adapted from reference 6.3, propellant was aged at 100°, 120°, and 140° for 1, 6, and 12 mo. Mean modulus of elasticity measurements are given for three propellant-aging temperatures and times. The columns for  $x_1^2$ ,  $x_2^2$ ,  $x_1x_2$ ,  $x_1y$ , and  $x_2y$  and the bottom row of summations are derived from the first two columns.

$x_1$	$x_2$	$y$	$x_1^2$	$x_2^2$	$x_1x_2$	$x_1y$	$x_2y$
100	1	360	10,000	1	100	36,000	360
120	1	352	14,400	1	120	42,240	352
140	1	347	19,600	1	140	48,580	347
100	6	358	10,000	36	600	35,800	1,548
120	6	350	14,400	36	720	42,000	2,100
140	6	345	19,600	36	840	48,300	2,070
100	12	347	10,000	144	1,200	35,700	4,284
120	12	349	14,400	144	1,440	41,880	4,188
140	12	343	19,600	144	1,680	48,020	4,116
1,080	57	3,151	132,000	543	6,840	377,520	19,845

The equations for finding the constants are as follows:

From equation (6.23),

$$\begin{aligned} 3,151 &= 9b_0 + b_1 1,080 + b_2 57 \\ 377,520 &= b_0 1,080 + b_1 132,000 + b_2 6,840 \\ 19,845 &= b_0 57 + b_1 6,840 + b_2 543 \end{aligned}$$

$$b_0 = \frac{\begin{array}{ccc} 3,151 & 1,080 & 57 \\ 37,7520 & 132,000 & 6,840 \\ 19,845 & 6,840 & 543 \\ \hline 9 & 1,080 & 57 \end{array}}{\begin{array}{ccc} 1,080 & 132,000 & 6,840 \\ 57 & 6,840 & 543 \end{array}}$$

$b_1$  and  $b_2$  are calculated in the same manner. Solving the simultaneous equations (6.23), the constants are  $b_0 = 383.98$ ,  $b_1 = -0.25$ , and  $b_2 = -0.6117$ . Therefore the equation for modulus of elasticity for the sample propellant is

$$y = 383.98 - 0.25 * x_1 - 0.6117 * x_2.$$

### 6.7.5 Advantages

A mathematical relationship can be determined, by hand or computer, when the relationship is not obvious by inspection.

### 6.7.6 Limitations

If the data are discrete (e.g., integer data), the actual line generated will only approximate the actual relationship.

## REFERENCES

- 6.1 Miller, I. and Freund, J.E.: "Probability and Statistics for Engineers." Second edition, Prentice Hall, Inc., Englewood Cliffs, NJ 07632, 1977.
- 6.2 Hines, W.W. and Montgomery, D.C.: "Probability and Statistics in Engineering and Management Science." John Wiley and Sons, Inc., 1990.
- 6.3 NASA-STD-8070.5A, "Trend Analysis Techniques." October 1990.

## 7. TOTAL QUALITY MANAGEMENT TOOLS

This section describes several TQM tools available to the system engineer analyst. TQM is applied to continuously improve performance at all levels of operation, in all areas of an organization, using all available human and capital resources. Improvement is addressed toward such areas as cost, quality, market share, schedule and growth. TQM is an ongoing effort that demands commitment and discipline.

A tool to assess an operation against other operations is the benchmarking technique which is discussed in section 7.1. The cause and effect technique relates identified problems to their causes, and this tool is discussed in section 7.2.

Concurrent engineering is more of an approach to quality management than a technique and it is an interaction of disciplines during the design but before production. This approach is discussed in section 7.3.

Three tools that attempt to improve the quality program are the cost of quality, design of experiments (DOE), and evolutionary operation (EVOP). The cost of quality tracks a quality program and attempts to identify ways to improve the program. This technique is discussed in section 7.4. Design of experiments varies all possible combinations of factors and levels in an attempt to obtain the optimum settings for a desired output. This technique is discussed in section 7.5. A methodology for improving quality by looking at the production process is the evolutionary operation technique, and it is discussed in section 7.6.

Group consensus techniques are often applied to solve problems. Three such tools are brainstorming, Delphi, and nominal group technique (NGT). These techniques are discussed in sections 7.7, 7.9, and 7.10, respectively.

A methodology for collecting data quickly and easily in a simplified manner is the checklist technique. This tool is discussed in section 7.8.

Another tool that might apply to the group consensus technique is the force field analysis. This methodology counts the positive and negative forces, as well as their magnitudes, that effect the results of a proposed solution or change in process. The force field analysis is discussed in section 7.11.

A methodology that is applied early in a design process is the quality function deployment (QFD) technique which is discussed in section 7.12. This technique is used to solve problems before the production phase begins and thus assists in the design of competitive products. By using a chart known as the house of quality, priorities are given to the possible solutions as they relate to the identified problems. Also, the product can be benchmarked against the competition in the areas of how well the product stacks up against the competition as far as handling the identified problems, and how well the product stacks up against the competition as far as meeting the appropriate engineering standards.

The final four tools that are discussed in this section are applied to improve a process. These tools are quality loss function, SPC, flowchart analysis and work flow analysis (WFA). Quality loss function, discussed in section 7.13, is a method of determining "loss to society" when a product is not at the mean but is still within specification limits. SPC, discussed in section 7.14, is a process improvement tool that helps identify problems quickly and accurately. The flowchart analysis, discussed in section 7.15, pictorially represents the steps of a process thus making it easier to eliminate nonvalued steps of the process. Finally, the WFA, discussed in section 7.16, examines the work process for possible improvements in performance and the quality of work life.

A summary of the advantages and limitations of each tool or methodology discussed in this section is presented in table 7-1.

Table 7-1. TQM tools and methodologies—Continued

Tool or Methodology	Section	Advantages	Limitations
Benchmarking	7.1	<ol style="list-style-type: none"> <li>(1) Helps meet customer requirements.</li> <li>(2) Helps establish goals and priorities.</li> <li>(3) Helps determine true measures of productivity.</li> <li>(4) Helps to attain and maintain a competitive position.</li> <li>(5) Helps identify and maintain awareness of industry best practices.</li> </ol>	<ol style="list-style-type: none"> <li>(1) Must be continuous in order to keep up with the latest industry changes.</li> <li>(2) Determining industry “best practices” is difficult and often subjective enough to be biased by the reviewing company’s “wants” rather than the reviewing company’s customer’s wants.</li> </ol>
Cause and effect diagrams	7.2	<ol style="list-style-type: none"> <li>(1) Enables quality analysis groups to thoroughly examine all possible causes or categories.</li> <li>(2) Useful in analyzing statistical process control (SPC) problems; SPC detects problems but can poses no solutions.</li> </ol>	Arriving at a group consensus is time-consuming.
Concurrent engineering	7.3	<ol style="list-style-type: none"> <li>(1) Shortens and makes more efficient the design-to-development life cycle by employing the interactions of functional disciplines by a cross-functional team.</li> <li>(2) Reduces costs in the design-to-development life cycle.</li> </ol>	<ol style="list-style-type: none"> <li>(1) The degree of success of this technique depends upon the degree of cooperation between the multifunctional team members.</li> <li>(2) Significant additional time, and associated funding, is required at the front end of a program to perform the coordinated planning. While time and money are saved overall within the effort, it is often difficult to “front-load” large tasks.</li> <li>(3) If design is pursued by projectized teams, the institutional knowledge of the organization becomes very difficult to capture or employ in the design decisions.</li> </ol>
Cost of quality	7.4	<ol style="list-style-type: none"> <li>(1) Helps to reveal and explain the more significant costs.</li> <li>(2) Activities and processes that need improvement can be prioritized.</li> <li>(3) Helps to reveal and explain the hidden costs of a product or service.</li> </ol>	<ol style="list-style-type: none"> <li>(1) The technique itself can be expensive, thus making its goals of saving/eliminating costs unachievable.</li> <li>(2) Measurement for measurement's sake is an easy paradigm to fall into; this technique is subject to misuse in this regard.</li> </ol>
Design of experiments	7.5	The technique optimizes product and process design, reduces costs, stabilizes production processes, and desensitizes production variables.	<ol style="list-style-type: none"> <li>(1) The performance of the analysis is time consuming and, the results generally do not include parameter interactions. Preknowledge of interaction significance is required to support appropriate DOE technique selection.</li> <li>(2) The DOE technique is often performed without a “verification experiment” in which the predicted “optimized” parameters are tested for performance (in agreement with the predictions). In, addition a mistake is often made by taking the “best” experiment’s parameters as an optimized set rather than an interpolated set.</li> <li>(3) Parameters must be interpolated from within the tested data set rather than extrapolated beyond it.</li> </ol>

Table 7-1. TQM tools and methodologies—Continued

Tool or Methodology	Section	Advantages	Limitations
Evolutionary operation	7.6	(1) The cost is very low, so it can be run continuously. (2) This technique increases a plant's capacity and thus profits will increase. (3) The tool is simple and relatively straightforward.	EVOP is slow, so progress is slow.
Brainstorming	7.7	The technique takes advantage of the ideas of a group to arrive at a quick consensus.	(1) The technique only proposes a solution but does not determine one. (2) The technique is limited by the ability of the group to achieve consensus.
Checklists	7.8	(1) The tool is quick and easy to use. (2) Checklists help to minimize errors and confusion.	Time must be taken to assemble a group to decide what data should be collected.
Delphi technique	7.9	(1) Useful in eliminating personality clashes. (2) Useful when powerful personalities are likely to dominate the discussion. (3) Inputs from experts unavailable for a single meeting are included.	(1) Arriving at a group consensus is time consuming. (2) Assembling the group participants is difficult/time-consuming.
Nominal group technique	7.10	Very effective in producing many new ideas/solutions in a short time.	(1) Assembling the group participants is difficult/time-consuming. (2) Divergence in weighting factors is common.
Force field analysis	7.11	Useful in determining which proposed solution, among many, will meet the least resistance.	The technique is time consuming in arriving at a consensus on the values (weights) of the forces, and is highly subjective.
Quality function deployment	7.12	(1) Helps organizations design more competitive, higher-quality, lower-cost, products easier and quicker. (2) Helps ensure quality products and processes by detecting and solving problems early. (3) Engineering changes, design cycle, and start-up costs are reduced. (4) Voice of the customer is heard. (5) The technique is proactive, not reactive. (6) Prevents problems from "falling through the crack." (7) The technique is cost-effective. (8) Easy to learn.	(1) Assembling the group participants is difficult/time-consuming. (2) The technique is not easy to perform.

Table 7-1. TQM tools and methodologies—Continued.

Tool or Methodology	Section	Advantages	Limitations
Quality loss function	7.13	(1) Evaluates loss at earliest stage of product/process development. (2) Useful results obtained quickly and at low cost.	(1) It may be difficult to convince manufacturers to apply the technique. (2) It is often difficult to characterize the loss function.
Statistical process control	7.14	(1) This technique determines the cause of variation based on a statistical analysis of the problem. (2) The technique improves process performance. (3) SPC helps identify problems quickly and accurately.	SPC detects problems but poses no solutions.
Flowchart analysis	7.15	(1) Allows the examination of and understanding of relationships in a process. (2) Provides a step-by-step picture that creates a common understanding about how the elements of the process fit together. (3) Comparing a flowchart to actual process activities highlights areas where policies are unclear or are being violated.	The development process is time consuming.
Work flow analysis	7.16	The technique increases productivity and improves working conditions.	(1) The technique requires cooperation between employees and management to be successful. (2) The observed operation may not be fully representative of a “typical” process that would occur without scrutiny.



## 7.1 Benchmarking

### 7.1.1 Description

Benchmarking, as described in reference 7.1, is a technique used to assess how an organization, or process, is performing against internal guidelines, competitors, or even noncompetitors that may be recognized as being superior. Benchmarking helps improve a process by recognizing priorities and goals. The technique must be continuously applied in order to be effective because practices constantly change (continuous improvement) affecting strategy. If the benchmarking process is performed once and forgotten, then the operation may become inefficient by not keeping up with the latest industry best practices.

### 7.1.2 Application

The benchmarking technique is typically performed in phase E but may also be performed in phase A or B. This technique can be applied when it is desirable to know the strengths and weaknesses of an organization's own operation. These strengths and weaknesses can then be compared to internal guidelines to evaluate the organization's conformance to those guidelines.

Benchmarking can be applied to identify the strengths for products that directly compete with the organization's specific product under consideration. The manufacturers of those competing products are probably using the same benchmarking technique to evaluate the competitors for their product. Once the strengths and weaknesses of competing products are known, the company can attempt to differentiate their capabilities in the marketplace.

By accomplishing this analysis, an organization can also incorporate the strengths of their competitors that exist in certain areas.

### 7.1.3 Procedures

As adapted from reference 7.3, the basic elements of benchmarking include the following:

- (1) Decide which process(es) or product(s) to benchmark.
- (2) Determine the criteria to benchmark, i.e., benchmark internally against established guidelines, benchmark against competitors, or benchmark against noncompetitors that are considered industry leaders.
- (3) Choose the particular characteristics of the operation or product to benchmark.
- (4) Collect data on the processes or products that are being benchmarked.
- (5) Analyze the data, prepare an action plan, and implement the plan.
- (6) Assess the results of all the changes.
- (7) Repeat the benchmarking technique, as necessary, in order to stay up-to-date with the applicable operation.

#### 7.1.4 Example

The following illustration, adapted from reference 7.3, shows an example of comparative benchmarking between one company's process and five competitors on a scale of 1 (worse) to 10 (better).

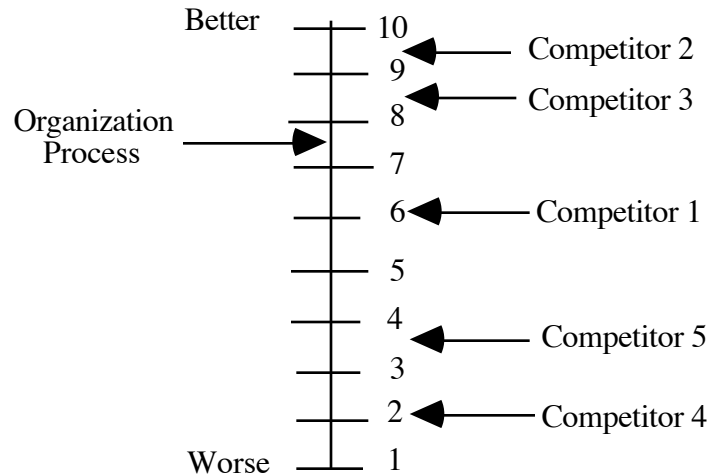

Figure 7-1. Comparative benchmarking.

This illustration reveals that this company needs to look closely at the operations of competitors 2 and 3 and consider implementing into their process any strengths that are discovered. This company should also look at those competitors rated lower on the scale and identify their weaknesses and ensure that those weaknesses do not exist in their operation.

#### 7.1.5 Advantages

- (1) Benchmarking helps meet customer requirements.
- (2) Benchmarking helps establish goals and priorities.
- (3) Benchmarking helps determine true measures of productivity.
- (4) Benchmarking helps to attain and maintain a competitive position.
- (5) Benchmarking helps identify and maintain awareness of industry's best practices.

#### 7.1.6 Limitations

- (1) The benchmarking process must be continuous in order to keep up with the latest industry changes.
- (2) Determining industry "best practices" is often difficult and subjective. The reviewing company may well bias their results based on company "wants" rather than customer "wants."

## **7.2 Cause and Effect Diagrams (Also Known as Fishbone Diagrams or Ishakawa Diagrams)**

### **7.2.1 Description**

The cause and effect diagram, as described in reference 7.3, graphically represents the relationships between a problem (effect) and its possible causes. The development process is started in a group session led by a trained facilitator. The problem is stated in terms acceptable to the group. Possible causes are listed. The group then assigns priorities to the causes and action plans are developed.

When a cause and effect diagram is constructed, thinking is stimulated, thoughts are organized, and discussions are begun. These discussions bring out many possible viewpoints on the subject. Once all participants reach a similar level of understanding about an issue, an expansion of ideas can then be examined.

Cause and effect diagrams are developed in a form, commonly referred to as “fish,” where the effect is found in a box to the right which is the head of the fish. The bones of the fish show the organized causes. The effects and causes can be expressed in words or data.

### **7.2.2 Application**

As adapted from reference 7.3, cause and effect diagrams are used to examine many different topics which include the following:

- (1) The relationships between a known problem and the factors that might affect it.
- (2) A desired future outcome and its related factors.
- (3) Any event past, present, or future and its causal factors.

The cause and effect diagram is useful in examining processes such as SPC, SPC problems, (sec. 7.14) problems. The cause and effect diagram technique is best applied in phase E but may also be applied in phase A or B. The technique is also useful in planning activities and brainstorming. The diagram is basically a controlled way of gathering and using suggestions through group consensus.

### **7.2.3 Procedures**

A cause and effect diagram, as adapted from reference 7.3, is developed in the following manner:

- (1) Define the effect as clearly as is possible and place it at the head of the fish. This effect represents the “problem” that is being investigated. As data are collected, the effect can be redefined, if necessary.
- (2) The group brainstorms the causes and lists them in no particular order. These causes are then studied and the causes that affect these causes are identified. This will continue until no new causes are thought of by the group.
- (3) Once all causes are identified, list all categories, then display the categories on the diagram.
- (4) The group then prioritizes the causes by multivoting. Each member of the group lists the causes in order of significance. Votes are counted and a final list is written.

- (5) The highest prioritized causes are listed on the diagram as the big bones. The next highest prioritized causes will be listed on the diagram as the medium bones. Finally, the least prioritized causes will be listed on the diagram as the small bones.
- (6) As categories and causes are included on the diagram, thinking may be stimulated and new causes may be identified.
- (7) Teams are then formed to research and report on preventive (i.e., proactive) measures.

#### 7.2.4 Examples

##### Example 1:

Assume the problem is design rework (fig. 7-2). The group fills in the probable root causes through “brainstorming” ideas (sec. 7.7). When complete, the group prioritizes the causes using multivoting. This is a technique where each person lists the causes in order of significance. Votes are counted and a final list is written. Teams are formed to research and report on preventive measures. In conclusion, a team has put their thoughts in writing and arrived at a consensus.

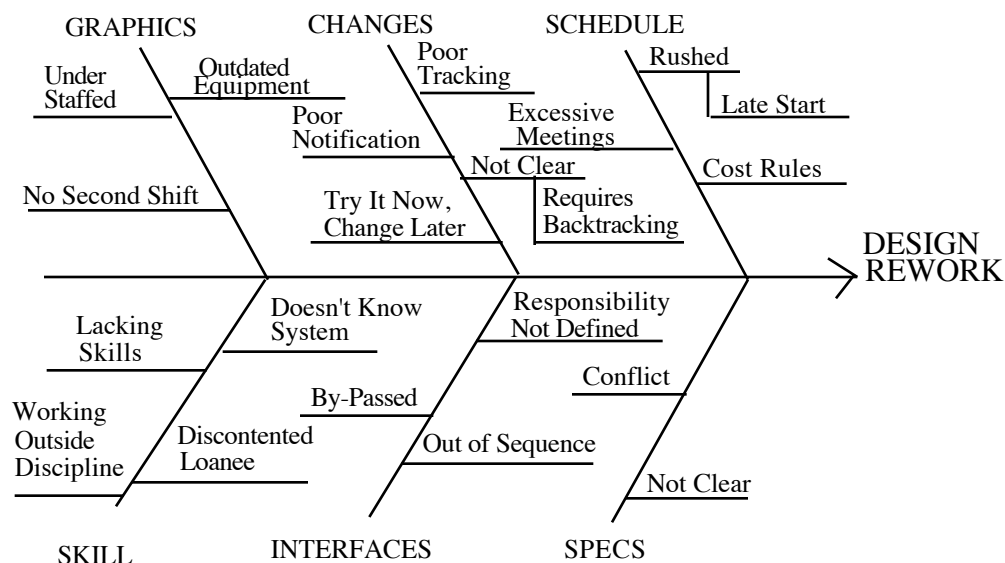

Figure 7-2. Design rework cause and effect diagram.

##### Example 2:

Figure 7-3 illustrates the resulting cause and effect diagram after the brainstorming session on identifying problems in receiving telephone messages. The brainstorming effort for this problem is covered in section 7.7.4.

#### 7.2.5 Advantages

- (1) The cause and effect diagram enables quality analysis groups to thoroughly examine all possible causes or categories.
- (2) The cause and effect diagram is useful in analyzing SPC problems. SPC detects a problem but can pose no solution.

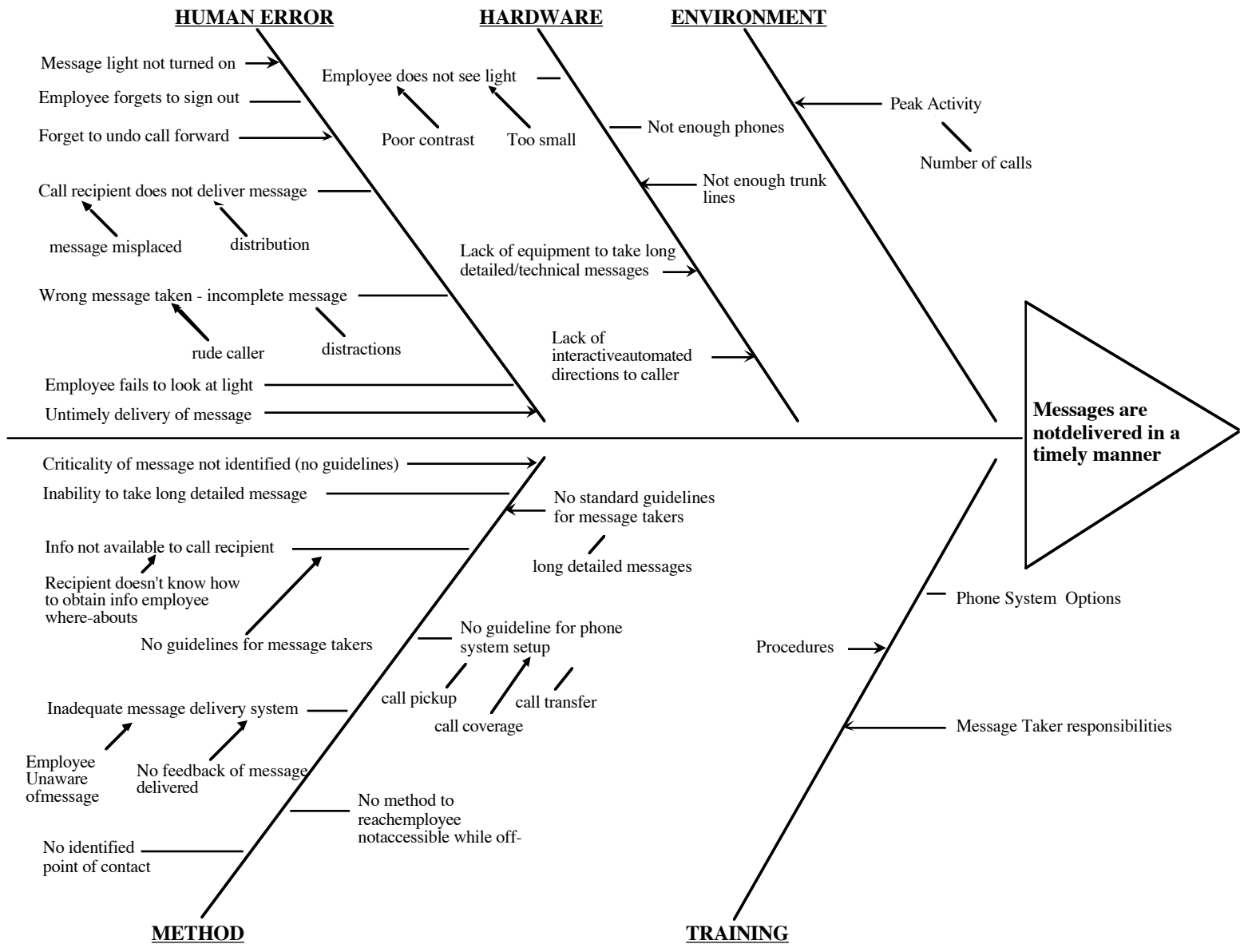

Figure 7-3. Cause and effect diagram on receiving telephone messages.

### 7.2.6 Limitations

The development of the cause and effect diagram can be time-consuming in order to arrive at a group consensus.

### 7.2.7 Bibliography

Kume, H.: "Statistical Methods for Quality Improvement." The Association for Overseas Technical Scholarships, 1985.

## 7.3 **Concurrent Engineering**

### 7.3.1 Description

Concurrent engineering is the interaction of technical disciplines during the design phase to produce a robust design prior to production. This process is more of an engineering approach to quality management than a technique.<sup>7.1</sup> The approach attempts to link and integrate, from the outset, all elements of the product life cycle from conception through disposal.

Traditionally, quality, and producibility do not review an element until after the design has been completed. Concurrent engineering, as described in reference 7.3, focuses on both the product and the process simultaneously. One method of achieving this approach is by forming multifunction teams consisting of engineers from several departments. This way, each department will follow the complete process simultaneously rather than one department examining the design and then passing it on to the next department and so on.<sup>7.4</sup>

The concurrent engineering approach has been known for many years although its use is just receiving widespread application in the United States.<sup>7.5</sup>

### 7.3.2 Application

Because the concurrent engineering approach is used to address the product and process simultaneously early in the design phase, it generally will save time and money. Through this technique, the team will establish design goals as well as perform trade-off analyses using such tools as QFD (sec. 7.12) and DOE (sec. 7.5). This technique is typically performed in phase C but may also be performed in phase B.

### 7.3.3 Procedures

The basic elements involved in applying concurrent engineering include the following, as adapted from reference 7.3:

- (1) Establish multifunction teams which include members from design, quality, safety, marketing, manufacturing, support, etc.
- (2) Select and use design parameters that will help identify and reduce variability in the production process.
- (3) Use such techniques as DOE, QFD, computer-aided design, robust design, group technology, and value analysis to extend the traditional design approach.

### 7.3.4 Example

Figure 7-4 illustrates an example of how concurrent engineering is applied. By using multifunctional teams, all phases of a product's life cycle are simultaneously examined, thus making the design process more efficient in terms of both cost and schedule.

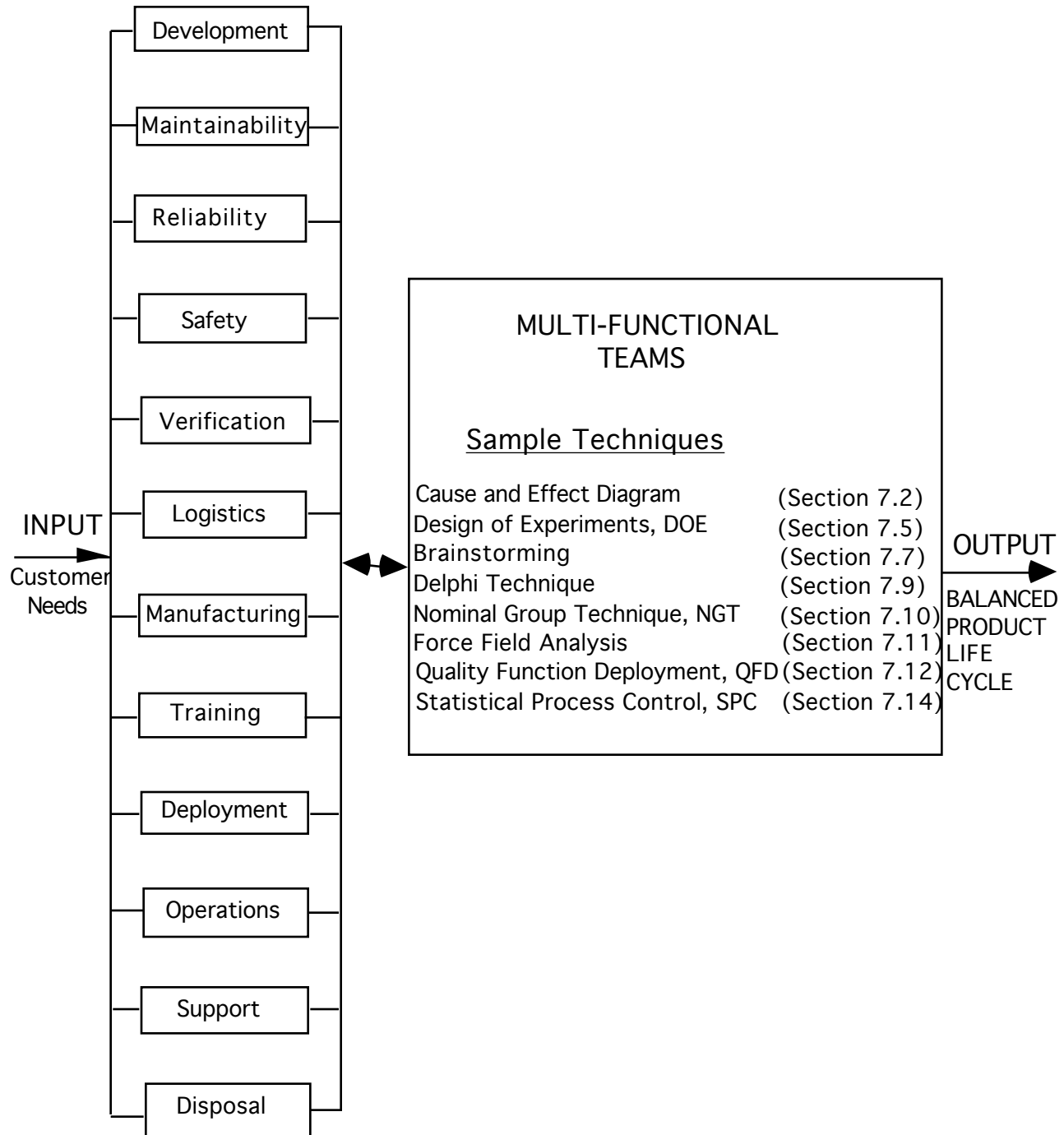

Figure 7-4. Concurrent engineering example.

### 7.3.5 Advantages

- (1) The concurrent engineering approach can be used to shorten and make more efficient the design-to-development life cycle by employing the interactions of functional disciplines by a cross-functional team.
- (2) The approach can also be applied to reduce costs in the design-to-development life cycle.

### 7.3.6 Limitations

- (1) The degree of success of this technique depends upon the degree of cooperation between the multifunctional team members.
- (2) Significant additional time, and associated funding, is required at the front end of a program to perform the coordinated planning. While time and money are saved overall within the effort, it is often difficult to “front-load” large tasks.
- (3) If design is pursued by projectized teams, the institutional knowledge of the organization becomes very difficult to capture or employ in the design decisions.

## **7.4 Cost of Quality**

### 7.4.1 Description

As described in reference 7.3, the cost of quality technique tracks the expense and benefit of a quality program. This technique can identify the unwanted cost of not doing the job right the first time as well as the cost of improving the job.

Cost of quality includes all of the costs associated with maintaining an acceptable quality program, as well as the costs incurred as a result of failure to reach the acceptable quality level. This technique allows the analyst to identify costs that are often hidden. Costs will not be reduced by merely tracking the cost of quality but the technique may point out areas where a greater return on investment could be made.

### 7.4.2 Application

The cost of quality technique is best applied in phase E. This technique is applied to understand the hidden costs of a product or service and to reduce or eliminate these costs. This technique can identify the most significant costs and thus make it possible to prioritize the activities and/or processes that may need improvement.

### 7.4.3 Procedures

The cost of quality technique is applied in the following manner:

- (1) Collect cost data for the following categories;
  - a. Internal failure (IF) costs
  - b. External failure (EF) costs
  - c. Appraisal (A) costs
  - d. Prevention (P) costs



(2) Data are trended periodically on the standard cost of quality curve shown in figure 7-5:

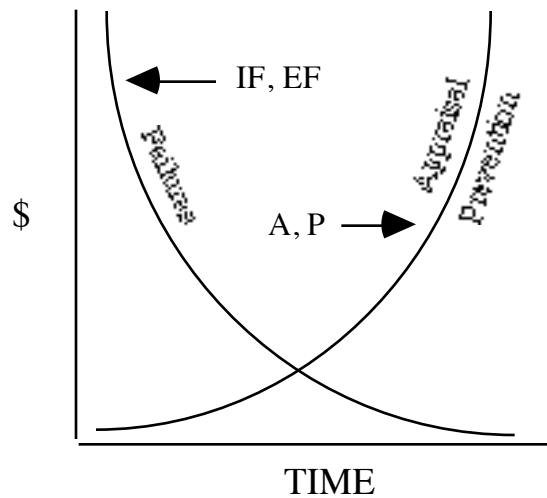

Figure 7-5. Standard cost of quality curve.

As appraisal (reactive) and prevention efforts increase, failures decrease. A significant prevention effort resulting in decreased failure warrants a decrease in appraisal (i.e., audits, inspections).

Prevention is the key. Concurrent engineering (sec. 7.3) helps achieve prevention. In some companies, the suggestion system and/or savings shown in process improvement measures are considered prevention.

Cost of quality programs requires a cross-functional, interdepartment team to agree on what constitutes a cost. Programs normally consist of three phases:

- (1) Initiation.
- (2) Development.
- (3) Solidified gains.

Failures are indirectly proportional to the appraisals/preventions. As failures decrease, manpower (reactive) should be decreased. Prevention costs run 2 percent or less of sales as a national average. There are indications that, to optimize cost-benefit relationships, it should be 10 percent. As the program progresses, prevention costs (proactive) should increase.

Collection of data can be on a ROM basis and need not involve finances. Be careful not to create a system and become so enamored with the system that the objective of savings is obscured.

Once data are collected and analyzed, they should be compared to a base. Examples are:

- (1) Manhours per drawing.
- (2) Direct cost per hour.
- (3) Drawings per month.

#### 7.4.4 Example

An example of a cost of quality data summary for a month is shown in table 7-2.

Table 7-2. Month's cost of quality.

Cost (\$)	Subject	P	A	IF	EF
32,000	Drawing Errors			X	
2,000	Training	X			
78,000	Erroneous Information			X	
18,000	Warranty Claims				X
10,000	Inspection/Audits		X		
<b>140,000</b>		2,000	10,000	110,000	18,000

The percentage breakdown is:

Prevention	=	2,000/140,000	=	1.43 percent
Appraisal	=	10,000/140,000	=	7.14 percent
Internal failure	=	110,000/140,000	=	78.57 percent
External failure	=	18,000/140,000	=	<u>12.86 percent</u>
				100 percent

The total failure cost is \$128,000 with only \$2,000 spent on prevention. This example is 98.57 percent reactive and only 1.43 percent proactive.

#### 7.4.5 Advantages

The following advantages were adapted from reference 7.6:

- (1) The cost of quality technique helps to reveal and explain the more significant costs.
- (2) Because of increased demands for time, energy, and money, it is helpful to develop a quality technique whereby activities and processes that need improvement can be prioritized. The cost of quality technique will accomplish this.
- (3) The technique helps to reveal and explain the hidden costs of a product or service.

#### 7.4.6 Limitations

- (1) If not done as part of an overall plan, the cost of quality technique can be expensive, thus making the goals of saving/eliminating costs unachievable.
- (2) Measurement for measurement's sake is an easy paradigm to fall into. This technique is subject to misuse in this regard.

### 7.5 Design of Experiments

#### 7.5.1 Description

The DOE technique is a control method of selecting factors, and levels of factors, in a predetermined way and varying possible combinations of these factors and levels. Quantitative results are analyzed to show interactions and optimum settings of factors/levels to produce a desired output.

This technique may make the design-to-production transition more efficient by optimizing the product and process design, reducing costs, stabilizing production processes, and desensitizing production variables.<sup>7.3</sup>

#### 7.5.2 Application

The design of experiments technique is typically performed in phase C but may also be performed in phase D. This technique is used to achieve a robust design as an alternative to experimenting in the production mode after the design has been completed. As described in reference 7.3, the following are among the applications for the DOE analysis:

- (1) Compare two machines or methodologies.
- (2) Examine the relative effects of various process variables.
- (3) Determine the optimum values for process variables.
- (4) Investigate errors in measurement systems.
- (5) Determine design tolerances.

#### 7.5.3 Procedures

As described in reference 7.3, the DOE technique is implemented as follows:

- (1) Determine all of the pertinent variables whether they be product or process parameters, material or components from suppliers, or environmental or measuring equipment factors.
- (2) Separate the important variables which typically number no more than four.
- (3) Reduce the variation on the important variables (including the control of interaction effects) through redesign, close tolerance design, supplier process improvement, etc.
- (4) Increase the tolerances on the less important variables to reduce costs.

### 7.5.4 Example

Data (yield in pounds) were recorded in table 7-3. For example, when  $A$  was at the low ( $A_1$ ) level (10 °F),  $B$  was at the high ( $B_2$ ) level (60 psi), and  $C$  was at the low ( $C_1$ ) level (30 GPM), yield was 2.1 lbs.

Table 7-3.  $2^3$  factorial design data.

	$A_1$		$A_2$	
	$B_1$	$B_2$	$B_1$	$B_2$
$C_1$	(1) 8.0	(7) 2.1	(6) 8.4	(4) 2.8
$C_2$	(5) 9.9	(3) 3.2	(2) 8.8	(8) 3.0

Numbers in parenthesis are standard cell designators. Normally four readings are averaged (e.g., 8.0 at  $A_1, B_1$ , and  $C_1$ , is an average of four data).

The orthogonal array is shown in table 7-4 along with the result of table 7-3. This array is used as a “run recipe” in the actual conduct of the experiment. For example, all factors ( $A, B, C$ ) are set at their low level during trial 1.

Table 7-4. Trial, effects, and results.

Trial	Main Effects			Second-Order Effects			Third-Order Effects	Results
	$A$	$B$	$C$	$AB$	$AC$	$BC$	$ABC$	
1	-	-	-	+	+	+	-	8.0
2	+	-	-	-	-	+	+	8.4
3	-	+	-	-	+	-	+	2.1
4	+	+	-	+	-	-	-	2.8
5	-	-	+	+	-	-	+	9.9
6	+	-	+	-	+	-	-	8.8
7	-	+	+	-	-	+	-	3.2
8	+	+	+	+	+	+	+	3.0

An example of the average of first order or main effects is shown using  $A_1$  data and cells 1, 3, 5, 7; thus:

$$A_1 \text{ effects} = \frac{8.0 + 3.2 + 9.9 + 2.1}{4} = 5.80.$$

An example of a second order interaction (e.g.,  $AB$ ) is calculated by averaging data in the cells where  $A$  and  $B$  are at like (L) levels and unlike (U) levels. They are:

$$AB_L = \text{cells } 1,5,4,8 = \frac{8.0 + 9.9 + 2.8 + 3.0}{4} = 5.93.$$

$$\frac{AB_U = \text{cells } 7,3,6,2 = 2.1 + 3.2 + 8.4 + 8.8}{4} = 5.63.$$

An example of the third order interaction (i.e.,  $ABC$ ) is calculated using cell data where the sum of the  $ABC$  subscripts are odd ( $O$ ), then even ( $E$ ). They are:

In cell #1, the factor levels are:  $A$ 's level is 1,  $B$ 's level is 1, and  $C$ 's level is 1. Therefore,  $1+1+1 = 3$ , which is an odd number. The four cells having odd sums of levels are 1, 2, 3, 4.

In cell #5, the factor levels are:  $A$ 's level is 1,  $B$ 's level is 1, and  $C$ 's level is 2. Therefore,  $1+1+2 = 4$ , which is an even number. The four cells having even sums of levels are 5, 6, 7, 8.

The calculations for all factors/levels are shown in table 7-5.

Table 7-5. Calculation of effects.

Summation	Cells	Computation	Effect
$A_1$	1, 3, 5, 7	$(8.0+3.2+9.9+2.1)/4$	5.80
$A_2$	2, 4, 6, 8	$(8.8+2.8+8.4+3.0)/4$	5.75
$B_1$	1, 2, 5, 6	$(8.0+8.8+9.9+8.4)/4$	8.78
$B_2$	3, 4, 7, 8	$(3.2+2.8+2.1+3.0)/4$	2.78
$C_1$	1, 4, 6, 7	$(8.0+2.8+8.4+2.1)/4$	5.33
$C_2$	2, 3, 5, 8	$(8.8+3.2+9.9+3.0)/4$	6.23
$AB_L$	1, 4, 5, 8	$(8.0+9.9+2.0+3.0)/4$	5.725
$AB_U$	2, 3, 6, 7	$(8.8+3.2+8.4+2.1)/4$	5.63
$AC_L$	1, 2, 7, 8	$(8.0+8.8+2.1+3.0)/4$	5.48
$AC_U$	3, 4, 5, 6	$(3.2+2.8+9.9+8.4)/4$	6.08
$BC_L$	1, 3, 6, 8	$(8.0+3.2+8.4+3.0)/4$	5.65
$BC_U$	2, 4, 5, 7	$(8.8+2.8+9.9+2.1)/4$	5.90
$ABC_O$	1, 2, 3, 4	$(8.0+8.8+3.2+2.8)/4$	5.70
$ABC_E$	5, 6, 7, 8	$(9.9+8.4+2.1+3.0)/4$	5.85

Steps:

- (1) Find  $C_{Avg}$ :

This is the overall average of all data in all cells or,

$$C_{Avg} = \frac{8+9.9+2.1+3.2+8.4+8.8+2.8+3}{8} = 5.78.$$

- (2) Find an estimate of  $\sigma_c$ :

$$\text{Estimated } \sigma_c = (C_{Avg})^{1/2}/(4)^{1/2} = (5.78)^{1/2}/2 = 1.202.$$

- (3) Ott<sup>7.7</sup> uses upper decision lines (UDL) and lower decision lines (LDL) instead of  $3\sigma$  control limits. The reason is that a decision of significant effects must be made when the plotted data are beyond these lines. Ott also has a table called “exact factors for one-way analysis of means,  $H_{\alpha}$  two-sided.”  $H_{.05}$  is found in the table. Then calculate the 95 percent UDL and LDL, where  $\alpha = .05$ , as follows:

$$UDL = C_{Avg} + H_{.05} (\text{Estimated } \sigma_c) = 5.78 + (1.39 \times 1.188) = 7.43$$

$$LDL = C_{Avg} - H_{.05} (\text{Estimated } \sigma_c) = 5.78 - (1.39 \times 1.188) = 4.13.$$

- (4) The data from table 7-5,  $C_{Avg}$ , UDL, and LDL are graphed in figure 7-6.

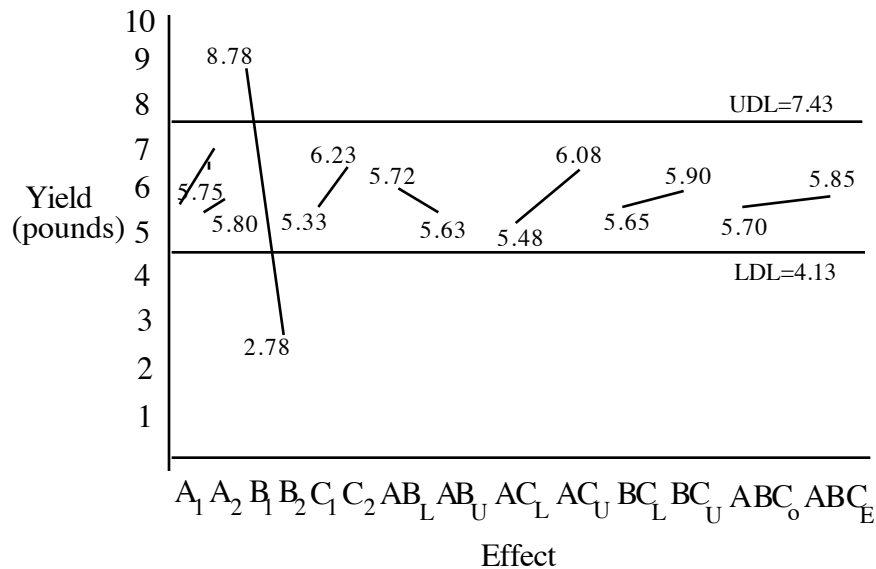

Figure 7-6. Factor/level effects graph.

#### Conclusion:

The main effect of  $B$  is very significant. Going from the high to the low level decreased yield 5 lbs. Raise  $B$  from 20 to 40 psi and run another experiment.

#### 7.5.5 Advantages

This technique makes the design-to-production transition more efficient by optimizing the product and process design, reducing costs, stabilizing production processes, and desensitizing production variables.<sup>7.3</sup>

#### 7.5.6 Limitations

- (1) The performance of the analysis is time-consuming and, if less than full factorial arrays are employed, the results will not include all parametric interactions. Preknowledge of interaction significance is required to support appropriate DOE technique selection.

- (2) The DOE technique is often performed without a “verification experiment,” in which the predicted “optimized” parameters are tested for performance (in agreement with the predictions). In addition, a mistake is often made by taking the “best” experiment’s parameters as an optimized set rather than an interpolated set.
- (3) In order to perform the analysis, parameters must be interpolated from within the tested data set rather than extrapolated beyond it.

### 7.5.7 Bibliography

Bhole, K.R.: “World Class Quality.” American Management Association, 1991.

## 7.6 Evolutionary Operation

### 7.6.1 Description

The EVOP technique is based on the idea that the production process reveals information on how to improve the quality of a process. The technique has a minimal disruption to a process and creates variation to produce data for analysis. Optimum control factor settings are identified for desired results.

Small, planned changes in the operating conditions are made and the results are analyzed. When a direction for improvement is identified, process modifications can be made. The changes can continue to be made until the rate of finding improvements decreases and then the changes can be applied to different operating variables to identify more directions for improvement.<sup>7,8</sup>

### 7.6.2 Application

The EVOP technique is best performed in phase E but may also be performed in phase D. This technique is applied to reveal ways to improve a process. An experiment may use two or more control factors (i.e., psi and degrees F are set) that produce a response (yield) known as response surface methodology (RSM) (sec. 6.7). The question that may be asked is, “What are the degrees F and psi settings that will produce maximum yield (pounds per batch)?”

Evolutionary operation works well with the SPC technique (sec. 7.14) in that SPC will monitor a process and EVOP will reveal ways to improve the process.

### 7.6.3 Procedures

The EVOP technique is applied in the following manner:

- (1) Choose two or three variables that are likely to affect quality.
- (2) Make small changes to these variables according to a predetermined plan.
- (3) Analyze the results and identify directions for improvement.
- (4) Repeat until optimal conditions are found.
- (5) The technique can then be applied to different variables.

## 7.6.4 Example

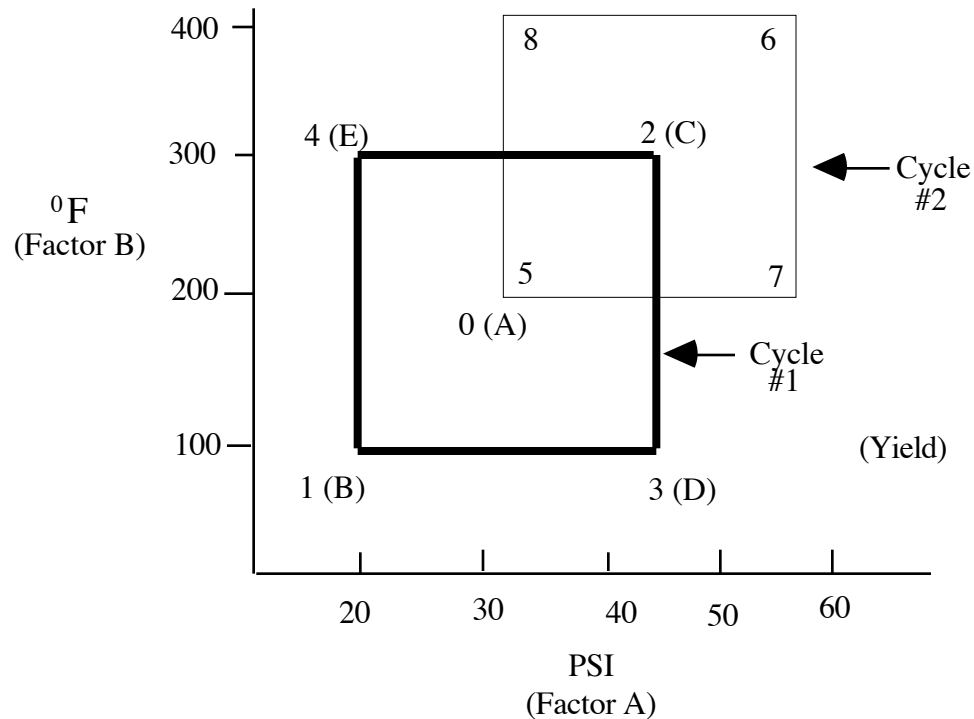

Figure 7-7. EVOP example.

Cycle No 1:

Per figure 7-7 above, select a reference point "0" (center of the box). The aim is to choose the psi and degrees F that yield maximum output (body of the graph). Output (yield) can be volume, length, etc. Corner No. 2 was maximum. Cycle No. 2 uses that corner as the reference point for the second box (cycle). Actually, this is a simple  $2^2$  factorial experiment where the low and high levels of two factors, i.e., degrees F and PSI were selected. Data for this example are shown in table 7-6.

Table 7-6. EVOP cycle No. 1 data.

RUN	TIME (A)	TEMPERATURE (B)	POSITION	YIELD
1	-	-	1	20
2	+	-	3	30
3	-	+	4	40
4	+	+	2	50
			0	10

Legend:

"-" = Low Level

"+" = High Level



Main effects are calculated for  $A$  and  $B$  and second order interaction  $AB$  as follows:

$$A_{\text{EFFECT}} = (\sum \text{High Levels} - \sum \text{Low Levels})/2$$

$$= [(30+50) - (20+40)]/2 = 10$$

$$B_{\text{EFFECT}} = (\sum \text{High Levels} - \sum \text{Low Levels})/2$$

$$= [(40+50) - (20+30)]/2 = 20$$

$$AB_{\text{INTERACTION}} = (\text{yield when } A \text{ and } B \text{ have like signs} - \text{yield when } A \text{ and } B \text{ have unlike signs})/2$$

$$= [(20+50) - (30+40)]/2 = 0.$$

The change in mean (CIM) and 2 standard error (S.E.) cannot be calculated until two cycles are complete. The S.E. is really a variation and encompasses 95-percent confidence within the normal curve. The 95-percent is symmetrical with a 5-percent level of significance, or a left and right tail of  $2^{1/2}$  percent each. The CIM tells when a minimum or maximum occurs by comparing the results of the four box corners to the reference point.

Cycle No. 2:

Corner No. 2 produced a maximum yield (i.e., 50) and becomes the new reference point. New data were recorded as shown in table 7-7.

Table 7-7. EVOP cycle No. 2 data.

RUN	TIME (A)	TEMPERATURE (B)	POSITION	YIELD
1	-	-	5	26
2	+	-	7	32
3	-	+	8	38
4	+	+	6	48
			0	18

Now, compare cycles (table 7-8).

Table 7-8. Comparison of EVOP cycle No. 1 and cycle No. 2 data.

CORNER	SUBJECT	YIELD AT POSITION				
		0	5	6	7	8
A	Sum From Cycle No.1	10	20	30	40	50
B	Average From Cycle No.1	10	20	30	40	50
C	New Yield Data	18	26	32	38	48
D	B -C	-8	-6	-2	2	2
E	New Sum = B + C	28	46	62	78	98
F	New Average = E/n	14	23	31	39	49

The new averages are used to calculate results. The levels of factors are determined by examining the cycle No. 2 box of figure 7-7. For example, when *A* is at the high level, use corners 6 and 7. When *A* is high and *B* is low, use corner 7, etc.

$$A_{\text{EFFECT}} = [(31+39)-(23+39)]/2 = 4$$

$$B_{\text{EFFECT}} = [(31+49)-(23+39)]/2 = 9$$

$$AB_{\text{INTERACTION}} = [(23+31)-(39+49)]/2 = -17.$$

The CIM is calculated by multiplying the reference point data by 4 (now representative of four corners) and letting the product be a sample, i.e.,  $n = 1$ . The product is subtracted from the sum of the four corners and divided by 5 (i.e., four corners are  $n = 4$  + the reference point of  $n = 1$ ):

$$\begin{aligned} 23+31+39+49 &= 142 \\ 4 \times 14 &= 56 \\ 86/5 &= 17.2 \end{aligned}$$

The standard deviation and 2 S.E. when  $n = 2$  are calculated using standard factors developed by Box and Hunter.<sup>7,9</sup> They are  $K = 0.3$ ,  $L = 1.41$ , and  $M = 1.26$ .

For the sample standard deviation:

$$\begin{aligned} s &= K (\text{corner "d" range}) \\ s &= 0.3 (-8 \text{ to } +2) = 3 \end{aligned}$$

for 2 S.E. For new averages/effects:

$$L(s) = 1.41 \times 3 = 4.23.$$

For CIM

$$M(s) = 1.26 \times 3 = 3.78.$$

Results:

Psi limits are  $4 \pm 4.23 = -0.23, 8.23$

Temperature limits are  $9 \pm 4.23 = 4.77, 13.23$ .

Conclusion:

Since the *AB* interaction = -17, there is a significant impact on the maximum yield. The psi can be negative, positive, or nil. The temperature is borderline, but it should increase yield if it is decreased. Select corner No. 7 and run a third cycle.

### 7.6.5 Advantages

The following advantages are adapted from reference 7.8:

- (1) The cost of running EVOP is very low so it can be run continuously.
- (2) EVOP will increase a plant's capacity and thus profits will also increase.
- (3) EVOP is simple and relatively straightforward.

### 7.6.6 Limitations

As described in reference 7.8, EVOP is slow, so progress is slow. If quick improvements are needed, then this technique is inappropriate.

## **7.7 Brainstorming**

### 7.7.1 Description

Brainstorming, as described in reference 7.3, is a group process wherein individuals quickly generate ideas on a particular problem, free from criticism. The emphasis is on the quantity of ideas, not the quality. In the end, the goal is to arrive at a proposed solution by group consensus. All members of the group are equals and each is free to express ideas openly. The technique is an excellent way of bringing out the creative thinking from a group.

### 7.7.2 Application

Brainstorming, as described in reference 7.1, is often used in business for such things as arriving at compromises during union negotiations, coming up with advertising slogans, identifying root causes of a problem, and finding solutions to a customer service problem.

If done properly, bashful yet creative people can be coaxed to propose good ideas. For some important brainstorming sessions, a facilitator is necessary. The facilitator should be knowledgeable in the brainstorming process and help as much as possible in the generation of ideas but should have no stake in the outcome of the brainstorming session. This technique is typically performed in phase A but may also be performed in phase C.

There are three phases of brainstorming, as adapted from reference 7.3:

- (1) Generation phase—group members generate a list of ideas.
- (2) Clarification phase—the group reviews the list of ideas to make sure all members understand each one, discussions occur.
- (3) Evaluation phase—the group eliminates duplication, irrelevancies, or issues that are off-limits.

### 7.7.3 Procedures

As described in reference 7.3, conduct a brainstorming session as follows:

- (1) Clearly state the purpose of the brainstorming session.
- (2) Group members can take turns expressing ideas, or a spontaneous discussion can occur.
- (3) Discuss one topic at a time.
- (4) Do not criticize ideas.
- (5) Expand on ideas from others.
- (6) Make the entire list of ideas available for all group members to review.
- (7) After discussions and eliminations, arrive at a final proposed solution by group consensus.

### 7.7.4 Example

A group was assembled to brainstorm the causes for telephone messages not being received in a timely manner. Each group member was given an opportunity to express ideas on the subject. A spontaneous discussion developed, with some group members expanding on the ideas of others. The following is a list of possible causes for the telephone message problem as a result of the brainstorming session:

- (1) Employee not at desk
- (2) Secretary not available
- (3) Volume of calls in-house
- (4) Too many incoming calls to receptionist
- (5) Employee misses message
- (6) Employee doesn't see light or message
- (7) Incomplete message taking
- (8) Message mishandled
- (9) Nonstandard message delivery system
- (10) Employee off-site
- (11) Criticality of message not identified

- (12) Phone grouping not identified
- (13) Whereabouts of employee unknown by call recipient
- (14) Not utilizing available resources
- (15) Caller leaves no message
- (16) Message light not turned on
- (17) Inadequate phone system
- (18) No feedback of message delivered
- (19) Lack of procedures
- (20) No identified points of contact
- (21) No answering machines
- (22) Complicated phone system
- (23) Forgetting to undo call-forwarding
- (24) People do not know how to use phone options
- (25) Secretary does not deliver messages
- (26) Secretary not in loop
- (27) Cannot find known message in loop
- (28) Wrong message taken
- (29) Untimely delivery of message
- (30) No guidelines for message taking
- (31) Not enough phones
- (32) Not enough trunk lines
- (33) Volume of calls
- (34) Congestion at receptionist's desk
- (35) Discontinuity at receptionist's desk
- (36) No beepers.

Following the brainstorming session for the causes of the problem, a cause and effect diagram was developed as shown in section 7.2.4, example 2. Once this was completed and more discussions were held, a proposed solution to the problem was presented.

#### 7.7.5 Advantages

The technique takes advantage of the ideas of a group to arrive at a quick consensus.

#### 7.7.6 Limitations

- (1) Brainstorming only proposes a solution but does not determine one.
- (2) The technique is limited by the ability of the group to achieve consensus.

## 7.8 Checklists

### 7.8.1 Description

A checklist, as described in reference 7.3, provides a list of checkoff items that enable data to be collected quickly and easily in a simplified manner. The data are entered on a clear, orderly form. Proper use of the checklist helps to minimize errors and confusion.

### 7.8.2 Application

Checklists should be laid out in advance or data may be omitted. If done right, the checklist will be easy to complete and will allow for quick entry of data. One common method of data entry on a checklist is hash marking.

Checklists are often used to collect data on such things as numbers of defective items, defect locations, and defect causes. This technique is best applied in phase E but may also be applied in phase A or B.

### 7.8.3 Procedures

As adapted from reference 7.3, a checklist is created in the following manner:

- (1) A group should decide ahead of time what data should be collected.
- (2) Make a draft of the checklist and ask the individuals who will fill out the form for input—revise as necessary.
- (3) Implement the checklist.
- (4) As data are collected, review the results and, again, revise the checklist, as necessary, to optimize use of the form.

### 7.8.4 Example

Table 7-9 illustrates a sample of the results of postflight hardware inspections for an imaginary SRM. The listed defects occurred on the corresponding motor where checked.

### 7.8.5 Advantages

- (1) The checklist is quick and easy to use.
- (2) Checklists help to minimize errors and confusion.

### 7.8.6 Limitations

Time must be taken to assemble a group to decide what data should be collected.

Table 7-9. Motor postflight checklist.

Defect Description	Motor Number									
	01	02	03	04	05	06	07	08	09	10
Outer Igniter Joint Discoloration			√	√			√	√	√	√
Aft Edge GEI Insulation Chips	√	√	√	√	√	√	√	√	√	√
Water Under Moisture Seal	√	√	√	√	√	√				
Polysulfide Porosity	√	√	√	√		√		√	√	√
Wet Soot on Rubber	√	√	√	√	√	√	√	√	√	√
Edge Insulation Exposure	√	√	√	√	√	√				√
Inhibitor Erosion	√	√	√	√	√	√	√	√	√	√

## 7.9 Delphi Technique

### 7.9.1 Description

The Delphi technique, as described in reference 7.1, is an iterative process that results in a consensus by a group of experts. The subject is presented to the experts. Without discussing the subject among themselves, the experts send their comments to a facilitator. The facilitator reviews the comments and eliminates those not applicable to the subject. Then, the comments are redistributed to the experts for further review. This iteration is repeated until a consensus is reached.

### 7.9.2 Application

The Delphi technique is best performed in phase A or B but may also be performed in phase E. This technique is a useful tool for finding a solution when personality differences exist between members of involved technical areas. A group of experts can examine the problem and, through consensus, the effects of the differences can be minimized. Another application for this technique is to allow all parties to have equal input when one personality may otherwise overpower another in a discussion.

### 7.9.3 Procedures

As adapted from reference 7.1, the Delphi technique is applied in the following manner:

- (1) Define the subject upon which the experts are to comment.
- (2) Assemble a monitor group to determine task objectives, develop questionnaires, tabulate results, etc.
- (3) Choose the experts, making sure they have no vested interest in the outcome.
- (4) Distribute the objectives, questionnaires, etc. to the experts for their initial set of opinions.

- (5) The monitor team consolidates the opinions and redistributes the comments to the experts, making sure that the comments remain anonymous.
- (6) Repeat steps 4 and 5 until a group consensus is reached.

#### 7.9.4 Example

The following example was adapted from reference 7.10:

A fault tree was generated for an SRM igniter, documenting all conceivable failure modes associated with the subsystems. A sample of part of the fault tree is shown in figure 7-8. The fault tree was then distributed to technical experts in the solid rocket industry. The expertise represented SRM experience in design, structures, and processing. These experts were asked to assign subjective estimations of failure probabilities of each mode and cause.

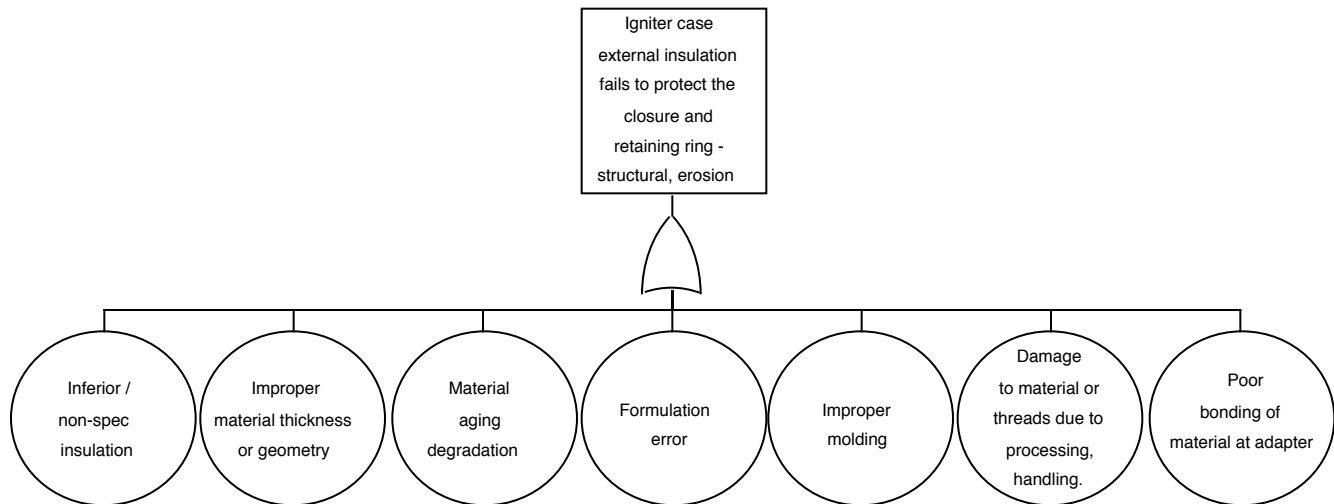

Figure 7-8. Sample of a partial igniter subsystem fault tree.

The relative probabilities were based on a rating system which utilized a tailored version of MIL-STD-882C<sup>7.11</sup> (sec. 3.12). The experts used letters to correspond to the descriptive words as follows:

<u>Level</u>	<u>Descriptive Words</u>	<u>Probability</u>
A	Infrequent	0.1
B	Remote	0.01
C	Improbable	0.001
D	Very improbable	0.0001
E	Almost nil	0.00001



Figure 7-9 shows an example of how the technical experts assigned estimations to each failure level.

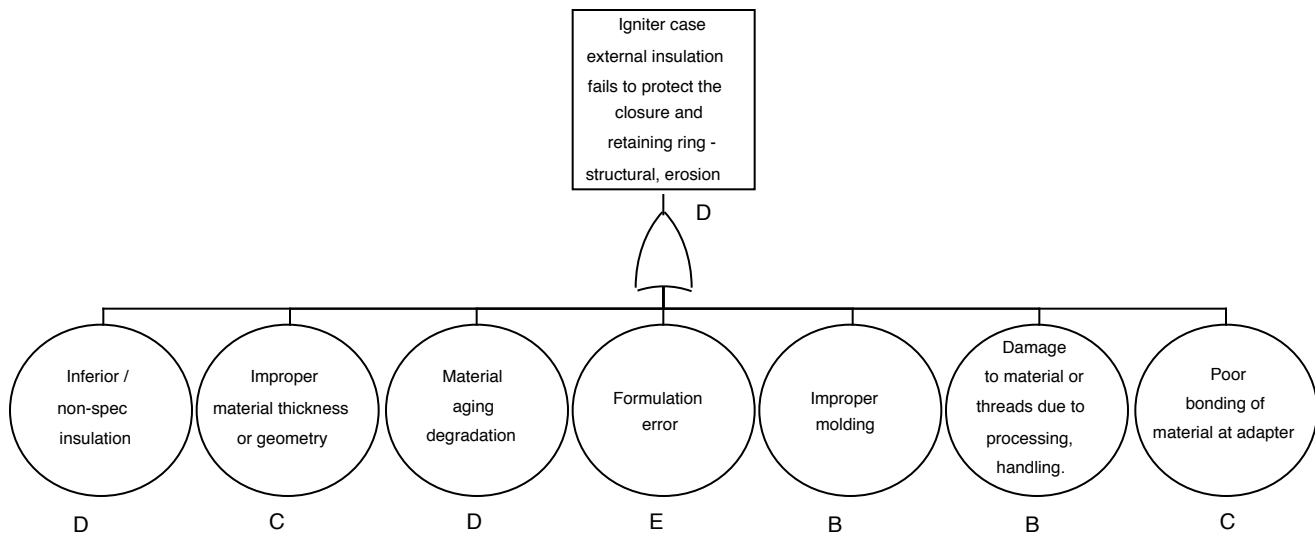

Figure 7-9. Fault tree sample with estimates assigned.

The team that generated the fault tree then took all the responses and assigned each failure level a failure probability based on the letters assigned by the experts. An average was derived for each failure level and applied to the fault tree. This labeled fault tree was distributed to the technical experts.

This process was repeated until a consensus on the assigned failure probabilities was arrived at by all of the technical experts.

#### 7.9.5 Advantages

- (1) This technique can be useful in eliminating personality clashes.
- (2) This technique can be useful when powerful personalities are likely to dominate the discussion.
- (3) Inputs from experts unavailable for a single meeting are included.

#### 7.9.6 Limitations

- (1) Arriving at a group consensus is time-consuming.
- (2) Assembling the group participants is difficult/time-consuming.

## 7.10 Nominal Group Technique

### 7.10.1 Description

The NGT, as described in reference 7.1, is another tool used to reach a group consensus. When priorities or rankings must be established, this decision-making process can be used. NGT is similar to brainstorming (sec. 7.7) and the Delphi technique (sec. 7.9), but it is a structured approach that is oriented toward more specialized problems. The group should be small (i.e., only 10 to 15 people), and every member of the group is required to participate. This technique is often categorized as a silent brainstorming session with a decision analysis process.

### 7.10.2 Application

The nominal group technique is an effective tool for producing many ideas and/or solutions in a short time. The technique can be used for many of the same applications as brainstorming and the Delphi technique. The NGT is best applied in phase A or B but may also be applied in phase E. Company internal technical problems can be solved, personality clashes can be overcome, and NGT can be used to develop new ideas to satisfy a particular problem.<sup>7.3</sup>

### 7.10.3 Procedures

The NGT, as adapted from reference 7.1, is applied in the following manner:

- (1) Generate the idea for discussion—a facilitator presents the problem and instructions to the team.
- (2) The team quietly generates ideas for 5 to 15 min—no discussion is allowed and no one leaves until everyone is finished.
- (3) The facilitator gathers the ideas round-robin and posts them in no particular order on a flip chart.
- (4) The ideas are then discussed by the group; no arguments, just clarifications. Duplications are eliminated.
- (5) Each member of the group silently sets priorities on the ideas.
- (6) The group votes to establish the priority or rank of each idea.
- (7) The votes are tabulated and an action plan is developed.

### 7.10.4 Example

The following example was adapted from reference 7.12:

The overall objective of this task was to define an appropriate methodology for effective prioritization of technology efforts required to develop replacement technologies (chemicals) mandated by imposed and forecast legislation.

The methodology used was a semiquantitative approach derived from QFD techniques (sec. 7.12). This methodology aimed to weight the full environmental, cost, safety, reliability, and programmatic implications of replacement technology development to an appropriate identification of viable candidates and programmatic alternatives.

A list of concerns that needed to be addressed was developed as follows in table 7-10.

Table 7-10. Replacement technology concerns.

<b><u>Chemical Concerns</u></b>		<b><u>Environmental Concerns</u></b>	
(1)	Number of sources	(1)	Clean air monitoring
(2)	Limits of resources	(2)	Pollution prevention
(3)	Availability	(3)	Toxic emissions
(4)	Stability	(4)	Emissions control
(5)	Drying ability	(5)	Ozone depletion potential
(6)	Base material compatibility	(6)	Chemical storage availability
(7)	Toxicity	(7)	Resource/ingredient recovery and recycling
(8)	Flash Point	(8)	Hazardous waste management
(9)	Ease of maintenance		
(10)	Historical data base		
(11)	Desirable reactivity		
(12)	Undesirable reactivity		
(13)	Lot-to-lot variability		
(14)	Age sensitivity		
(15)	Shelf life		
(16)	Bondline thickness		
<b><u>Process Concerns</u></b>		<b><u>Cost Concerns</u></b>	
(1)	Contaminants removed	(1)	Manpower dollars
(2)	Process steps	(2)	Operations dollars
(3)	Parts processed at one time	(3)	Facilities dollars
(4)	Required surface preparation	(4)	Materials dollars
(5)	Bondline thickness	(5)	Chemical dollars
(6)	Process interaction	(6)	Other hardware dollars
(7)	Bondline strength required	(7)	Contracts dollars
(8)	Operator sensitivity	(8)	Change of specifications dollars
(9)	Lot-to-lot variability	(9)	Specification verification dollars
(10)	General cleaning ability	(10)	Change of drawings dollars
(11)	Surface requirements	(11)	Development of procedure dollars
(12)	Possibility of stress corrosion cracking	(12)	Emissions control equipment dollars
(13)	Useful life of process part	(13)	Emissions control testing dollars
(14)	Damage caused by process		
<b><u>Regulatory Concerns</u></b>		<b><u>Scheduling Concerns</u></b>	
(1)	OSHA requirements	<b><u>Federal, State, and Local</u></b>	
(2)	State environmental laws	(1)	Research
(3)	Local environmental laws	(2)	Trade studies
(4)	Federal environmental requirements	(3)	Modification in planning
(5)	Future federal regulations	(4)	Specification documentation
		(5)	Requirements documentation
		(6)	Drawing/design changes
		(7)	Production time
		(8)	Testing
		(9)	Vendor selection and certification
<b><u>Safety Concerns</u></b>		<b><u>Present Program Schedule</u></b>	
(1)	Worker exposure limits	(1)	Research
(2)	Spill response plans	(2)	Trade studies
(3)	Fire response plans	(3)	Modification in planning
(4)	Explosion response plans	(4)	Specification documentation
		(5)	Requirements documentation
		(6)	Drawing/design changes
		(7)	Production time
		(8)	Testing
		(9)	Vendor selection and certification

A necessary step for developing a QFD matrix was to assign weighting factors to all of the concerns. A group of 10–15 people knowledgeable in the subject of chemical replacement was assembled to weight the concerns as follows:

- (1) Each individual of the group, without discussion, generated ideas about the importance of each concern.
- (2) The facilitator collected the lists of ideas and posted them in no particular order.
- (3) The ideas were discussed to clear up any misunderstandings.
- (4) The group then voted on establishing the weighting factors on each concern.

Table 7-11 shows the list of assigned weighting factors based on a scale of 1 (least critical) to 20 (most critical).

#### 7.10.5 Advantages

NGT is very effective in producing many new ideas/solutions in a short time.

#### 7.10.6 Limitations

- (1) Assembling the group participants is difficult/time-consuming.
- (2) Limiting discussion often limits full understanding of others ideas, with consequent divergence of weighting factors as a likely result.

### **7.11 Force Field Analysis**

#### 7.11.1 Description

The force field analysis, as described in reference 7.1, is a technique that counts both the number and magnitude of positive and negative forces that effect the results of a proposed solution or change in process. The analysis of these positive and negative forces generally occurs after performing a brainstorming session (sec. 7.7) or a cause and effect diagramming session (sec. 7.2).

This technique categorizes the identified forces as either positive or negative, and assigns a value (weight) to each force. All positives and negatives are added and the more positive the total, the more likely the proposed solution is the correct one. The more negative the total, the more likely the proposed solution is not correct. A strategy is then developed to lessen the negative forces and enhance the positive forces.

#### 7.11.2 Application

The force field analysis is best applied in phase D or E. This analysis is often applied in determining which proposed solution, among many, will meet the least resistance. The number of forces should not be too high (i.e., < 20) or other more sophisticated approaches should be considered.

Table 7-11. Concerns with assigned weighting factors.

<b><u>Chemical Concerns</u></b>			<b><u>Environmental Concerns</u></b>		
(1)	Number of sources	7	(1)	Clean air monitoring	12
(2)	Limits of resources	7	(2)	Pollution prevention	12
(3)	Availability	14	(3)	Toxic emissions	15
(4)	Stability	15	(4)	Emissions control	12
(5)	Drying ability	14	(5)	Ozone depletor potential	15
(6)	Base material compatibility	17	(6)	Chemical storage availability	10
(7)	Toxicity	13	(7)	Resource/ingredient recovery and recycling	10
(8)	Flash point	13	(8)	Hazardous waste management	12
(9)	Ease of maintenance	8			
(10)	Historical data base	9	<b><u>Cost Concerns</u></b>		
(11)	Desirable reactivity	13	(1)	Manpower dollars	17
(12)	Undesirable reactivity	13	(2)	Facilities dollars	15
(13)	Lot-to-lot variability	11	(4)	Materials dollars	14
(15)	Shelf life	9	(5)	Chemical dollars	16
(16)	Bondline thickness	7	(6)	Other hardware dollars	14
			(7)	Contracts dollars	12
<b><u>Process Concerns</u></b>			(8)	Change of specifications dollars	13
(1)	Contaminants removed	15	(9)	Specification verification dollars	13
(2)	Process steps	9	(10)	Change of drawings dollars	11
(3)	Parts processed at one time	7	(11)	Development of procedure dollars	12
(4)	Required surface preparation	12	(12)	Emissions control equipment dollars	15
(5)	Bondline thickness	7	(13)	Emissions control testing dollars	12
(6)	Process interaction	9			
(7)	Bondline strength required	9	<b><u>Scheduling Concerns</u></b>		
(8)	Operator sensitivity	12	<b><u>Federal, State, and Local</u></b>		
(9)	Lot-to-lot variability	11	(1)	Research	9
(10)	General cleaning ability	13	(2)	Trade studies	8
(11)	Surface requirements	14	(3)	Modification in planning	9
(12)	Possible stress corr. crack.	14	(4)	Specification documentation	10
(13)	Useful life of process part	14	(5)	Requirements documentation	11
(14)	Damage caused by process	13	(6)	Drawing/design changes	8
			(7)	Production time	11
<b><u>Regulatory Concerns</u></b>			(8)	Testing	14
(1)	OSHA requirements	13	(9)	Vendor selection & certification	12
(2)	State environmental laws	14			
(3)	Local environmental laws	14	<b><u>Present Program Schedule</u></b>		
(4)	Federal env. requirements	15	(1)	Research	10
(5)	Future federal regulations	14	(2)	Trade studies	11
			(3)	Modification in planning	10
<b><u>Safety Concerns</u></b>			(4)	Specification documentation	11
(1)	Worker exposure limits	12	(5)	Requirements documentation	11
(2)	Spill response plans	13	(6)	Drawing/design changes	10
(3)	Fire response plans	14	(7)	Production time	11
(4)	Explosion response plans	16	(8)	Testing	12
			(9)	Vendor selection & certification	11

Application of the force field analysis requires a proposed solution and inputs to the process. These inputs might come from using group consensus techniques like those discussed in earlier sections. Also, assigning the value (weight) to each force might also require group consensus techniques.

### 7.11.3 Procedures

The force field analysis, as adapted from reference 7.1, is performed in the following manner:

- (1) Identify the proposed solution or change in process.
- (2) Determine the forces, positive and negative, that might effect the implementation of this proposed solution.
- (3) Separate the forces into positive and negative lists and assign a value (weight) to each force. Arriving at these values may be achieved by use of a group consensus technique like the Delphi technique (sec. 7.9).
- (4) Establish a strategy to lessen the negative forces and enhance the positive forces.

### 7.11.4 Example

Management met to discuss the possibility of approving a suggestion to allow employees to work flex-time. The group identified the positive and negative forces that will affect this decision as follows:

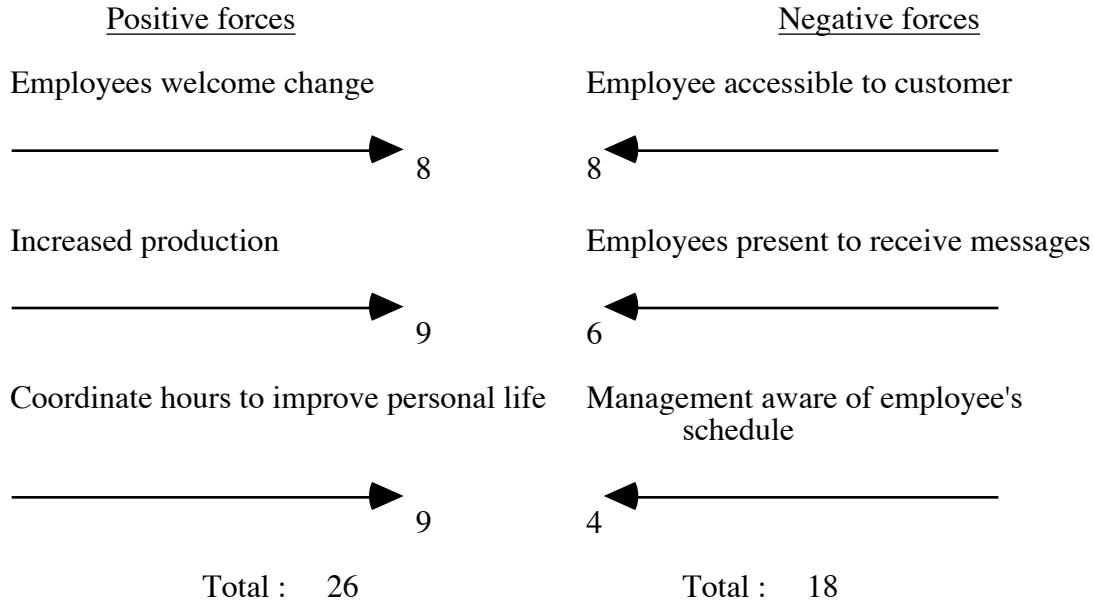

Figure 7-10. Force field analysis example.

The positive forces clearly outweighed the negative forces. Management developed a strategy to lessen the magnitudes of the negative forces listed and thus enabled the proposal of flex-time to be approved.

### 7.11.5 Advantages

The force field analysis is useful in determining which proposed solution, among many, will meet the least resistance.

### 7.11.6 Limitations

This technique is time-consuming in arriving at a consensus on the values (weights) of the forces, and is highly subjective.

## 7.12 Quality Function Deployment

### 7.12.1 Description

QFD, as described in reference 7.12, is a conceptual map that provides the means for cross-functional planning and communications. This technique is a method of turning the customer's voice into engineering language. A matrix is developed known as the "house of quality" and the main elements of the matrix are the WHATs (customer concerns) and the HOWs (quantifiable solutions to the concerns). The reason for the name "house" is because the matrix is shaped like a house and elements are separated into rooms, as illustrated in figure 7-11.

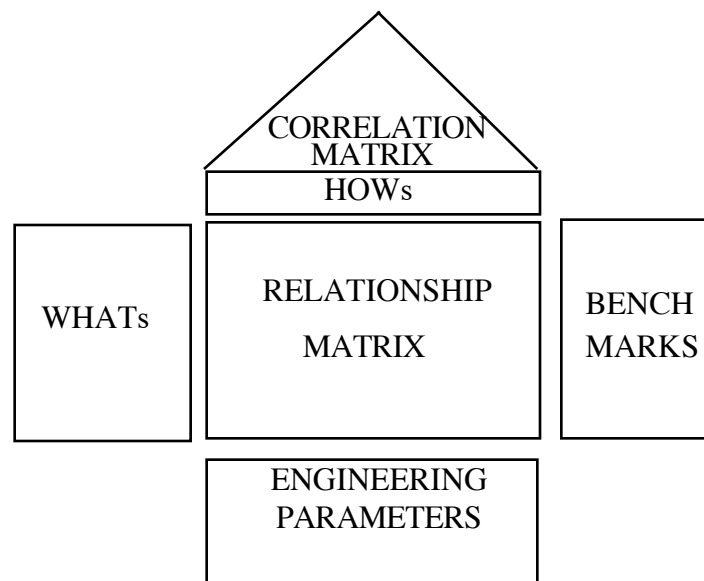

Figure 7-11. House of quality.

The other rooms of the house are defined as follows:

- (1) Relationship matrix—This is the main body of the matrix, and it is the relationship between each WHAT and HOW. These relationships are denoted by symbols or numbers which correspond to weak, medium, and strong relationships.

Example : 1 = Weak  
 3 = Medium  
 9 = Strong.

- (2) Correlation matrix—This is often called the “roof” of the house. The roof relates each of the HOWs to each other and is also denoted by symbols or numbers which correspond to strong-positive, medium-positive, strong-negative and medium-negative.

Example: ++ = Strong-positive  
 + = Medium-positive  
 -- = Strong-negative  
 - = Medium-negative.

These data become important when the consideration of trade-off factors is necessary.

- (3) Benchmarks—This room is used to assess how well the product stacks up against the competition.
- (4) Engineering parameters—This room is used to assess how well the product stacks up to applicable target values.

Inputs to the QFD matrix will require group sessions which will involve brainstorming (sec. 7.7), cause and effect analysis (sec. 7.2) and other techniques that might help to gather information about customer requirements<sup>7.1</sup>

### 7.12.2 Application

The QFD technique is typically performed in phase C but may also be performed in phase A or B. This technique may be used by every function in the producing organization and in every stage of product development. The main focus is to implement change during design rather than during production.

Not only does the QFD matrix allow assessment of the product against the competition and other benchmarks, it also enables a prioritization of the HOWs, i.e., the results of the QFD analysis can give overall ratings for each quantifiable solution to the stated concerns. These ratings indicate which solutions are most important and need to be considered first. The most important reason for the QFD analysis is to identify the problem areas and the quantifiable solutions to these problems early in the design phase so these issues will not have to be faced during production, which could lead to delays and higher costs.

### 7.12.3 Procedures

As adapted from reference 7.13, a QFD analysis is performed as follows:

- (1) List and prioritize the WHATs that concern the customer. These items are generally very vague and require further definition. This list will be placed in rows at the left side of the house. Each item is weighted for importance to the customer.
- (2) List the HOWs that address the WHATs. This list of quantifiable solutions to the WHATs will be placed in columns and because the WHATs are so vague, one or more HOWs can relate to each WHAT.
- (3) Correlate the WHATs and HOWs. This correlation is entered into the main body of the matrix (relationship matrix). These relationships are weighted as noted in section 7.12.1.
- (4) List the benchmarks and perform an assessment. The assessment can be performed on both the HOWs and the WHATs. Areas for improvement can easily be noted here by comparing how well this product stacks up against the competition.



- (5) Correlate the HOWs to each other as noted in section 7.12.1, step 2.
- (6) Calculate the scores of the relationships. The score for each HOW as related to each WHAT is determined by multiplying the weighting factor for each WHAT by the corresponding value in the relationship matrix. The overall ratings for the values in table 7-12 are calculated as follows:

Table 7-12. QFD matrix sample calculations.

		H O W s			
		Solution 1	Solution 2	Solution 3	
W H A T S	Concern 1	10	3	9	1
	Concern 2	15	1	9	3
	Concern 3	12	9	1	9
	Overall Rating		153	237	163

Solution 1 would have an overall rating of  $(10 \times 3) + (15 \times 1) + (12 \times 9) = 30 + 15 + 108 = 153$ .

Solution 2 would have an overall rating of  $(10 \times 9) + (15 \times 9) + (12 \times 1) = 90 + 135 + 12 = 237$ .

Solution 3 would have an overall rating of  $(10 \times 1) + (15 \times 3) + (12 \times 9) = 10 + 45 + 108 = 163$ .

This example reveals that solution 2 is the most important HOW in achieving the collective WHATs.

#### 7.12.4 Example

A planning team for an automobile company performed a task of trying to anticipate problem areas in a design so they can be improved upon or eliminated early. Six customer concerns (WHATs) for an automobile were studied:

- (1) Good performance
- (2) Quiet
- (3) Safe
- (4) Good gas mileage
- (5) Affordable
- (6) Roomy.

Next, all possible solutions to these concerns (HOWs) were identified and they are:

- (1) 0–60 (s)
- (2) Fuel economy (mpg)
- (3) Horsepower
- (4) Weight (klbs)
- (5) Emissions (ppm)
- (6) Noise level (dB)
- (7) Energy absorption rate (mph)
- (8) Purchase price (k\$)
- (9) Maintenance cost (\$)
- (10) Head room (in)
- (11) Elbow room (in)
- (12) Leg room (in).

This automobile company was benchmarked (sec. 7.1) against three competitors as to how well each company stacks up to meeting each WHAT. The benchmark rating scale used was from 1 (low) to 5 (high).

Engineering parameters were identified for each HOW. The first parameter for each was the desired parameter for this company to target. The next row delineated the current company practice for each parameter. A final entry for these parameters, was the percent difference between the company's present level and the desired target.

The roof was included which identified the relationships between the HOWs. The rating scale used was as follows:

9 = Strong positive

3 = Medium positive

–3 = Medium negative

–9 = Strong negative.

Finally, weighting factors were given to each customer concern. That is, on a scale of 1 (low) to 10 (high), each concern was rated for importance. All of the data were coordinated and a QFD matrix was developed as shown in figure 7-12.



## Conclusions:

- (1) Looking at the overall ratings showed that the two most important solutions in achieving the collective concerns were the horsepower rating followed by the time taken to get from 0 to 60 mph.
- (2) The benchmarking of this company to the three main competitors revealed that, overall, this company rated as well or better than the competitors. The matrix showed that this company could stand to improve on achieving a quiet ride, getting better gas mileage, and making the automobiles roomier.

### 7.12.5 Advantages

- (1) The QFD technique helps organizations design more competitive, higher-quality, and lower-cost products easier and quicker, and is aimed primarily at the development of new products.
- (2) This technique helps ensure quality products and processes by detecting and solving problems early.
- (3) Engineering changes are reduced.
- (4) The design cycle is reduced.
- (5) Startup costs are reduced.
- (6) The voice of the customer is heard.
- (7) The technique is proactive instead of reactive.
- (8) The technique prevents problems from “falling through the crack.”
- (9) The technique is economical.
- (10) The QFD technique is easy to learn.

### 7.12.6 Limitations

- (1) Assembling the group participants is difficult/time-consuming.
- (2) Even though the analysis is easy to learn, it is not easy to perform.

### 7.12.7 Bibliography

Hauser, J.R. and Clausing, D.: “The House of Quality.” Harvard Business Review, No. 88307, vol. 66 , No. 3, May–June 1988.

Sullivan, L.P.: “Quality Function Deployment.” Quality Process, June 1986.

## 7.13 Quality Loss Function

### 7.13.1 Description

The quality loss function technique is a Taguchi method of determining the “loss to society” when a product is not at the true value (i.e., mean) although it still lies within specification limits.

As described in reference 7.14, in order to develop a function to quantify the loss incurred by failure to achieve the desired quality, the following characteristics must be considered:

- (1) Larger is better (LIB)—the target is infinity.
- (2) Nominal is best (NIB)—a characteristic with a specific target value.
- (3) Smaller is better (SIB)—the ultimate target is zero.

Traditionally, manufacturers have considered a product “perfect” if it lies between the lower and upper specification limits as illustrated in figure 7-13.

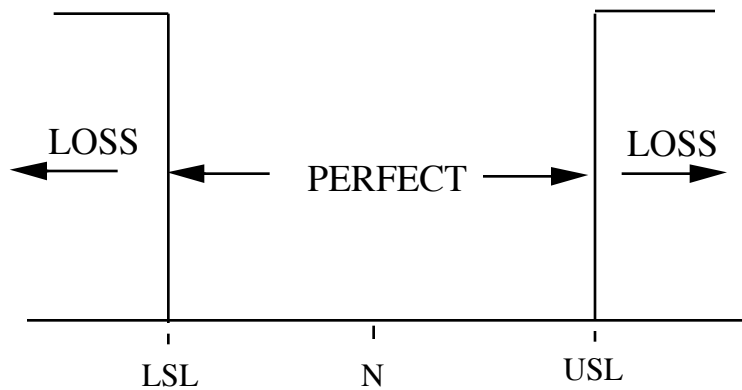

Figure 7-13. Traditional view to meeting specification.

where

LSL = Lower specification limit

N = Nominal

USL = Upper specification limit.

The problem with this approach is that when “tolerance stackup” (sec. 4.3) is considered, difficulties arise. If two mating parts are being manufactured, they may fall at opposite ends of their specific tolerance and they may not assemble properly.

### 7.13.2 Application

The quality loss function technique is typically performed in phase E but may also be performed in phase D. This technique is used to improve a process, thus it can be used for productivity improvement measurements. For each quality characteristic there is a function which defines the relationship between economic loss (dollars) and the deviation of the quality characteristic from the nominal value.<sup>7.14</sup>

The application of the quality loss function  $L(y)$  also reveals indications of customer dissatisfaction. The further the characteristic lies from the nominal value, the more problems may arise and thus more customer complaints. These complaints, in turn, will lead to a financial loss.

Of course, just because a characteristic meets the target value, it does not mean that the quality of the product is adequate. The specification limits may be out of line.

### 7.13.3 Procedures

As described in reference 7.14, the  $L(y)$  around the target value  $n$  is given by:

$$L(y) = k (y-n)^2 \quad (7.1)$$

where

$L(y)$  = loss in dollars per unit product when the quality characteristic is equal to  $y$ .

$y$  = the value of the quality characteristic, i.e., length, width, concentration, surface finish, flatness, etc.

$n$  = target value of  $y$ .

$k$  = a proportionality constant.

By applying equation (7.1) and examining figure 7-14, it can be seen that  $L(y)$  is a minimum at  $y = n$  and  $L(y)$  increases as  $y$  deviates from  $n$ .

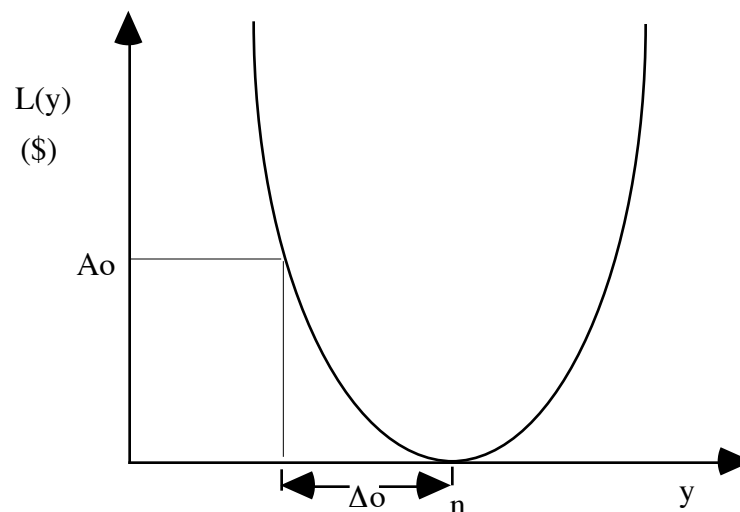

Figure 7-14. Quality loss function for NIB.

where

$A_o$  = consumer's loss

and

$\Delta o$  = tolerance.

To apply the quality loss function equation, proceed as follows:

- (1) As given in equation (7.2):

$$L(y) = k (y - n)^2$$

- (2) To calculate a dollar loss at some value ( $y$ ), first calculate  $k$ .

$$k = \frac{A_o}{\Delta o^2} \quad (7.2)$$

- (3) Calculate  $L(y)$ .

#### 7.13.4 Example

Determine the dollars lost at some value ( $y$ ) per figure 7-15.

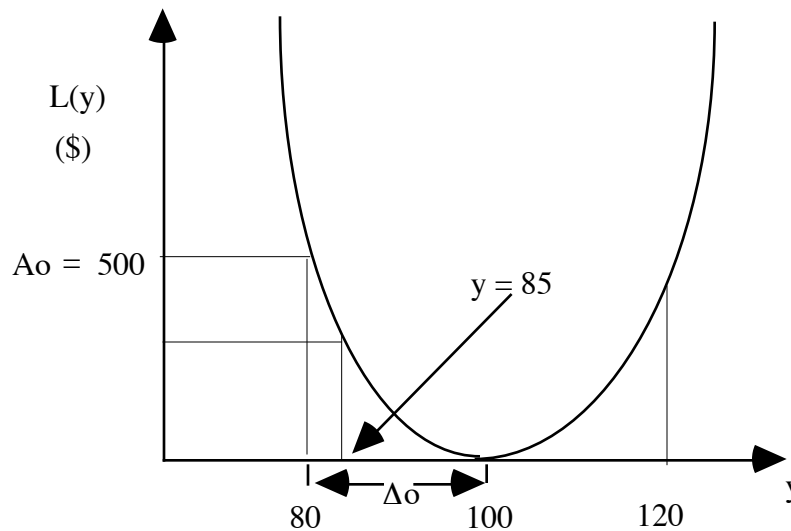

Figure 7-15. Quality loss function example.

$$L(y) = k (y - n)^2$$

$$k = \frac{A_o}{\Delta o^2} = \frac{500}{(20)^2} = \frac{500}{400} = 1.25$$

$$L(y) = 1.25 (85 - 100)^2 = 1.25 (-15)^2 = 1.25 (225) = \$281.25.$$

### 7.13.5 Advantages

- (1) The quality loss function technique is an excellent tool for evaluating loss at the earliest stage of the product/process development.
- (2) Useful results can be obtained quickly and at low cost.

### 7.13.6 Limitations

- (1) With many manufacturers following the guidelines that their product is adequate if certain measurements are within the specification limits, it is difficult to convince them to apply this technique.
- (2) It is often very difficult to calculate the quality loss function for a given process. The parameter  $y$  and the relationship to any  $A_o$  are generally obscure.

## 7.14 Statistical Process Control

### 7.14.1 Description

SPC is a method of using statistics applied to the results of a process to control the process. Historical data of the performance of the process (or operation of hardware) are statistically analyzed to predict future performance or to determine if a process is “in control.” A process is defined as “in control” if there are only random sources of variation present in the process and the associated data. In these cases, the data can correctly be investigated with the standard methods of statistical analysis. If the data are not “in control,” there is some special cause of variation present in the process, and this is reflected in the data from that process. In these cases, this section on SPC assumes that the data variability is still reasonably distributed around the mean, and these procedures are applicable. If these procedures lead to a result of special cause variation at nearly every data point, these procedures cannot be correctly applied.

### 7.14.2 Application

The SPC technique is best performed in phase E. This technique is used to determine if special causes of variation are present in a process, or if all variation is random. In other words, SPC is used to ensure that a product is being produced consistently, or is about to become inconsistent. Thus, SPC can be used to isolate problems in a process before defective hardware is delivered. This technique can be used for measurement type data (real numbers) or attribute data. There are two types of attribute data—binomial data and poisson data. Binomial data have a given number of outcomes, e.g., three of four parts on an assembly can be defective. Poisson data have an unlimited number of possible outcomes, e.g., a yard of material may have 1, 10, or 100 flaws.

### 7.14.3 Procedures

The basic steps for conducting SPC are:

- (1) Decide how to group the data. Subgroups should be chosen to show the performance of the part or process of interest. For example, if a machine is producing several parts at a time, the parts produced at one time will be a logical subgroup.
- (2) Construct a control chart and range chart (see below).



- (3) Determine and apply control limits to the data.
- (4) Determine if any control limits are violated. If any control limits are violated, a special cause is indicated. In addition to the specific control limits, the analyst must examine the data plot for other visual indications of special causes in the data. Any particular pattern, for example, would indicate a special cause is present. The use of engineering judgment is critical to extracting the maximum amount of data from the SPC plots.
- (5) Determine the special cause. This may require Pareto analysis or engineering judgment using past experience.
- (6) Implement a fix for the special cause of variation.
- (7) Plot the data to ensure that the fix has been effective.

Control charts (sec. 5.2) are made as follows:

- (1) A plot is made of the data, in temporal order of generation, on a scatter plot.
- (2) If the data are subgrouped, the mean values of the subgroups are plotted.
- (3) A range chart is made where the range is plotted for each subgroup. If the subgroup size is one, a moving range chart is made. The moving range for an abscissa (“x” value) is the absolute value of the difference of the ordinates for the abscissas and the previous abscissa.
- (4) Determine control limits as discussed below.
- (5) Apply appropriate rules to detect a lack of control (see below).

There are typically three control limits based on the population standard deviation of the process (sec. 6). If negative values of data are possible, there are six control limits. They are the mean of data plus or minus one, two, and three standard deviations. If one datum exceeds the mean plus three standard deviations, a rule 1 violation exists. If two of three data points exceed the mean plus two standard deviations, a rule 2 violation exists. If four of five consecutive data points exceed the mean plus one standard deviation, a rule 3 violation exists. If eight consecutive points exceed the mean, a rule 4 violation exists. If negative values of data are possible, these rules apply if the values are below the control limit.

For real number data, the population standard deviation is determined from the average of the data by the equation:

$$s = R_m/d_2 \quad (7.3)$$

where  $s$  is the population standard deviation,  $R_m$  is the mean of the subgroup ranges, and  $d_2$  is a factor for converting the mean range to the population standard deviation. The constant  $d_2$  can be found in reference 7.15. If the data are not subgrouped, the average moving range is used. The moving range is the difference between a data point and the preceding point.

For binomial data, the population standard deviation is given by the equation

$$s = (p_m(1 - p_m)/n_m)^{0.5} \quad (7.4)$$

where  $p_m$  is the mean fraction defective, and  $n_m$  is the number in each sample.

For Poisson data the population standard deviation is given by the equation

$$s = (C)^{0.5} \quad (7.5)$$

where  $C$  is the average number of nonconformities per subgroup.

The discussion in this section has thus far been centered on a violation of a control limit indicating a special cause of variation being present. The special cause itself may be a shift in the entire data pattern defined as a mean shift or population shift. In these cases, the limits should be modified or recalculated to be appropriate for the subsequent data points. A mean shift is generally attributable to an obvious special cause such as a change in process, material, operator, cutting head, or specification. Data points immediately preceding and following a mean shift should not be grouped together for any other analyses.

#### 7.14.4 Example

A hypothetical drill jig is set up to drill five holes in a component. The five holes are of the same size and have the same positional tolerance. Provide a control chart showing the performance of the drill jig with the data below, and determine the source of any deviation from nominal hole position. Table 7-13 below shows the deviation from nominal hole size and position made by each drill guide for each part.

Table 7-13. Nominal hole size deviations and drill guide positions.

Part #	Tempora l Process Order	Hole 1	Hole 2	Hole 3	Hole 4	Hole 5	Range	Mean
2	1	2	1	2	3	1	2	1.8
1	2	1	2	3	4	3	3	2.6
4	3	3	3	1	2	2	2	2.2
5	4	2	2	2	3	1	3	2.0
3	5	4	2	3	2	2	2	2.6
6	6	2	1	2	3	1	2	1.8
7	7	6	3	1	2	3	5	3.0
10	8	7	2	2	1	3	6	3.0
8	9	9	3	2	2	2	7	3.6
9	10	10	2	1	3	4	9	4.0
	range	9	2	2	2	2	5	
	mean	4.6	2.1	1.9	2.5	2.2	4.1	2.66

The mean and range for each part and each hole is shown in the table 7-13. Each part will be considered to be a subgroup. If the variation between holes is of primary interest, it could be better to treat each hole as a subgroup. However, the performance of the entire jig is of primary interest in this example, so each part will be treated as a subgroup. The first control chart (fig. 7-16) shows the performance of the jig with the mean plotted against the time-phased process order. The UCL is shown. The UCL is calculated using equation (7.6) to obtain the population standard deviation, multiplying it by 3 and adding it to the mean of the mean deviation. Notice that the mean measurement is increasing for the last few parts, but no control limits are exceeded.

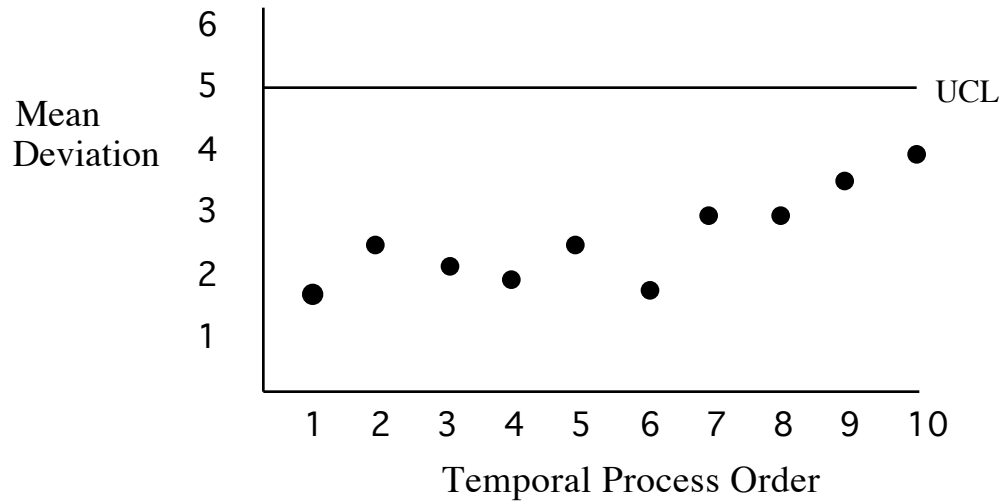

Figure 7-16. Control chart showing mean deviation for each part.

The second chart (fig. 7-17) is a range chart that shows the mean range for each part plotted against part number (note that it remains in temporal order). Part number 9 exceeded the UCL range (UCLR). UCLR is given by the equation:

$$UCLR = R_m[1 + 3(d_3/d_2)] \quad (7.6)$$

where  $R_m$  is the mean range and  $d_3$  is a factor for converting the mean range to the standard deviation of the range. The constant  $d_3$  can be found in reference 7.15. This shows that the within-group variation is increasing more than the group-to-group variation.

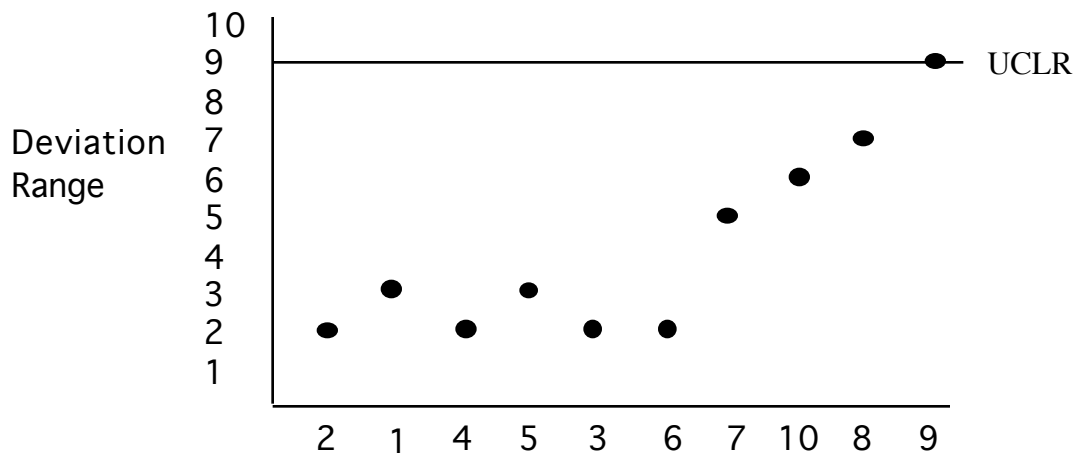

Figure 7-17. Range chart showing mean range for each part.

The third chart (fig. 7-18) shows a Pareto chart (sec. 5.6) where the mean deviation is plotted against hole number. By examination, it can be seen that drill guide position 1 is producing holes with a mean measurement that is higher than the other drill guide positions.

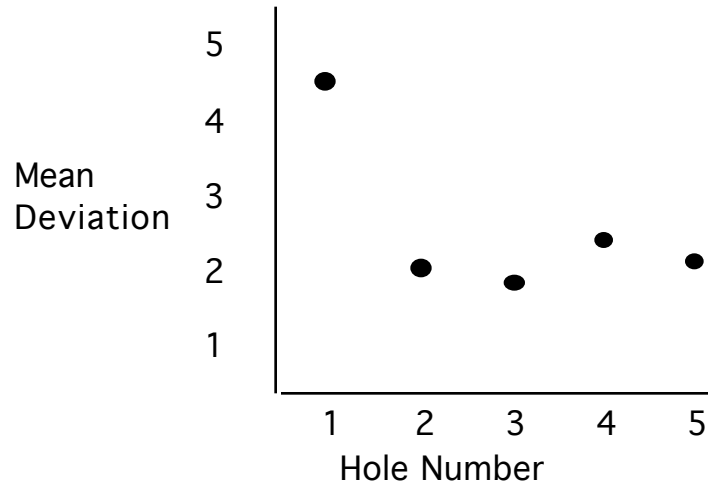

Figure 7-18. Pareto chart showing mean deviation for each hole guide.

The fourth chart, figure 7-19, shows the deviation produced by hole guide 1 plotted against part number. By examination, it can be seen that the deviation is increasing starting with part 7.

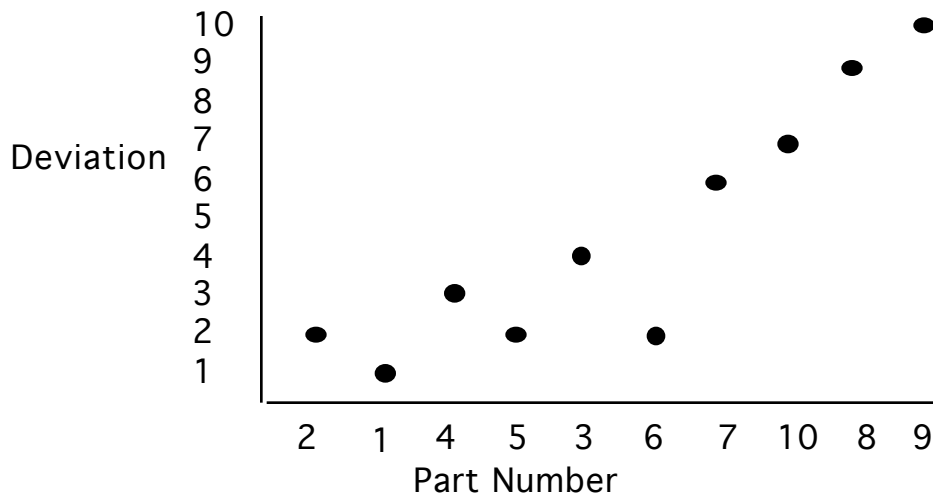

Figure 7-19. Control chart showing mean deviation for hole guide 1.

#### 7.14.5 Advantages

- (1) SPC is an excellent technique for determining the cause of variation based on a statistical analysis of the problem.
- (2) The technique improves process performance.
- (3) SPC helps identify problems quickly and accurately.

### 7.14.6 Limitations

SPC detects problems but poses no solutions.

### 7.14.7 Bibliography

Miller, I., and Freund, J.E.: "Probability and Statistics for Engineers." Second edition, Prentice Hall Inc., Englewood Cliffs, NJ 07632.

Nolan, T.W., and Provost, L.P.: "Understanding Variation." Quality Progress, May 1990.

Weisbrodand, S., and McFarland, C.S., "A New Approach to Statistical Process Control in a Test Environment: The Empirical Delta Control Chart." IEEE Melbourne, FL, 1991.

## 7.15 Flowchart Analysis

### 7.15.1 Description

A flowchart, as described in reference 7.3, is a pictorial representation of the steps in a process where each step is represented by a block. The review of a flowchart allows the elimination of nonvalue added steps. When prepared by a group, the chart represents a consensus. The flowchart analysis is a useful tool for determining how a process works. By studying how process steps relate to each other, potential sources of problems can often be identified.

Many different types of flowcharts are useful in the continuous improvement process. Flowcharts often used are the top-down flowchart, the detailed flowchart, and the work flow diagram. The top-down flowchart, figure 7-20, presents only the major and most fundamental steps in a process. This chart makes it easy to visualize the process in a single, simple flow diagram. Key actions associated with each major activity are listed below their respective flow diagram steps. A top-down flowchart can be constructed fairly quickly and easily. This type of flowchart is generally developed before attempting to produce the detailed flowcharts for a process. By limiting the top-down flowchart to key actions, the probability of becoming bogged down in the detail is reduced.

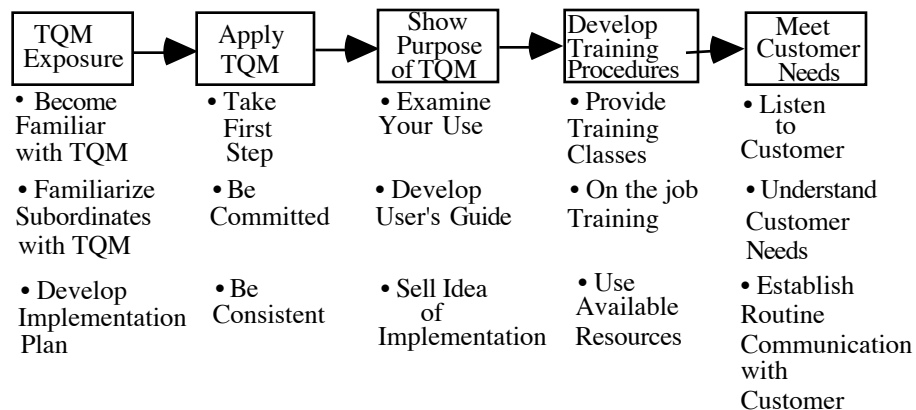

Figure 7-20. Example of top-down flowchart.

The detailed flowchart, figure 7-21, gives specific information about process flow. At the most detailed level, every decision point, feedback loop, and process step is represented. Detailed flowcharts should only be used when the level of detail provided by the top-down or other simple flowcharts is insufficient to support the analysis of the process.

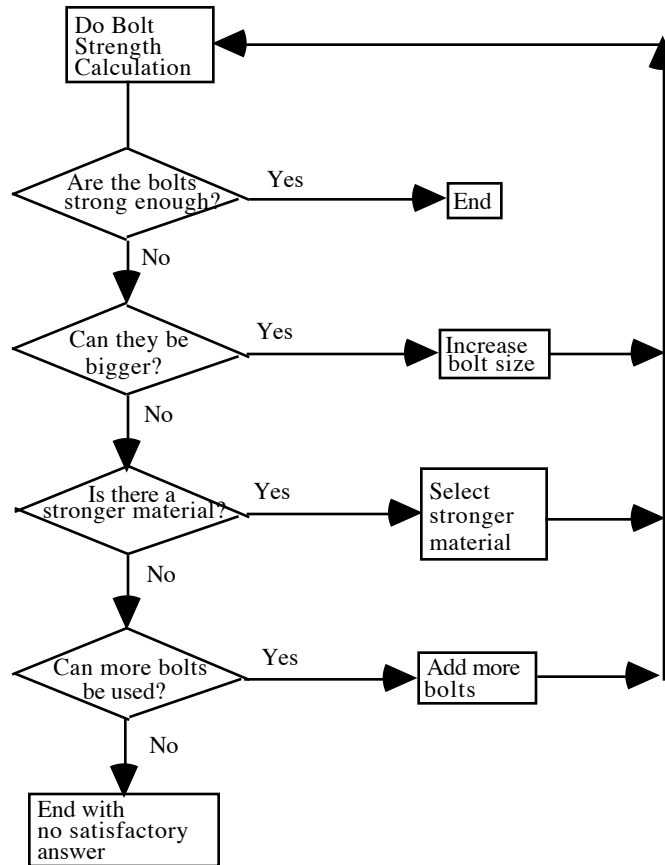
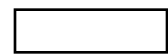
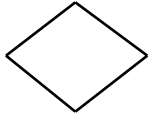

Figure 7-21. Example of detailed flowchart.

The work flow diagram (section 7.15.4) is a graphic representation of how work flows through a facility. This diagram is useful for analyzing flow processes, illustrating flow efficiency, and planning process-flow improvement. Figure 7-22 illustrates the most common flowchart symbols.



**Activity Symbol** - Action that is taking place.



**Decision Symbol** - Yes/No Decision.

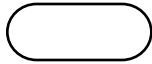

**Terminal Symbol** - Beginning or end of process.



**Flow Line** - Shows direction of process flow.

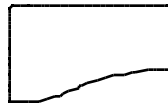

**Document Symbol** - Indicates a document source.

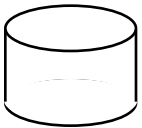

**Data Base Symbol** - Indicates a database source.

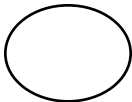

**On Page Connector** - Indicates point elsewhere on a large page where process continues.



**Off Page Connector** - Indicates point on another page where process continues.



**Brick Wall** - Shows obstacle beyond your control.

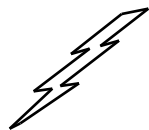

**Inspiration** - Indicates a possible solution.



**Black Hole** - Indicates a problem that consumes all resources.



**Dead End** - Shows particular path of a process has no acceptable solution.



**Magic Happens Here** - Indicates that, with a breakthrough, we can continue the process.

Figure 7-22. Common flowchart symbols.

### 7.15.2 Application

A flowchart is best applied in phase B but may also be applied in phase E. This chart is used to provide a picture of the process prior to writing a procedure. Flowcharts should be created, then procedures written to follow the flowchart. The chart should be included as an appendix in the procedure. Flowcharts can be applied to anything from material flow to the steps it takes to service or sell a product.

### 7.15.3 Procedures

A flowchart, as described in reference 7.1, is prepared in the following manner:

- (1) A development team creates a diagram that defines the scope of the task to be undertaken. Also identified are the major inputs and outputs.
- (2) Create a data flow diagram. Start with executive level data that are involved in the process, followed by department data and finally branch data.
- (3) Using the data, create an initial model. The team should walk through the process and look for any details that need to be clarified, added, or deleted.
- (4) Make a data dictionary. This ensures that everyone involved in the project has a consistent understanding of the terms and steps used.
- (5) Add the process symbols.
- (6) Revise, as necessary.

### 7.15.4 Example

The following example, figure 7-23, illustrates a work flow diagram for encountering problems with a copy machine.

### 7.15.5 Advantages

The following advantages are adapted from reference 7.16:

- (1) Flowcharts allow examination and understanding of relationships in a process.
- (2) Flowcharts provide a step-by-step picture that creates a common understanding about how the elements of a process fit together.
- (3) Comparing a flowchart to actual process activities highlights areas where policies are unclear or are being violated.

### 7.15.6 Limitations

The flowchart development process can be time-consuming.



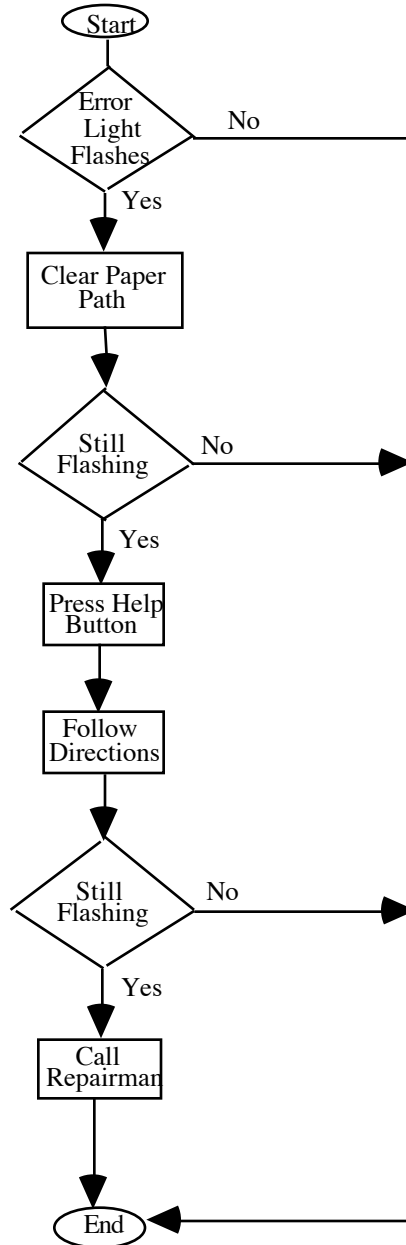

Figure 7-23. Work flow diagram example.

## 7.16 Work Flow Analysis

### 7.16.1 Description

A WFA, as described in reference 7.1, examines the work process for possible improvements in performance and quality of work life. This technique is really a special case of flowcharting (sec. 7.15). The goal is to overcome the excuses for not changing work habits on the part of the employee as well as management. Such excuses are, “It has always been done this way,” and “It’s not my responsibility.”

### 7.16.2 Application

A WFA is best applied in phase E. The analysis is performed in an employee/management partnership, where the goal for each party is to improve productivity as well as the quality of work life. The technique will work if executed by a partnership of management and employees.

### 7.16.3 Procedures

As adapted from reference 7.1, a WFA is performed in the following manner:

- (1) Collect data concerning the operation being analyzed. This can be done by observing the operation or asking questions, but not by reading an operations plan that would tell how the operation is supposed to be done.
- (2) Flowchart the process (sec. 7.15).
- (3) Research and collect ideas on how to improve the operation from any sources available.
- (4) Define the desired performance versus the actual performance.
- (5) Identify the gaps in performance and propose changes to eliminate these gaps.
- (6) Analyze these changes by using a multifunctional team.
- (7) Once the changes are agreed upon, prototype them on a small basis in a certain area or shift.
- (8) Once the bugs are ironed out and the changes are operating smoothly, implement them on a large-scale basis.
- (9) Flowchart the new operation and revise the operating procedure documentation to reflect the changes.

### 7.16.4 Example

An analysis team was assembled to analyze the food preparation process at a local fast food restaurant in an attempt to find areas where the operation could be run more efficiently. The steps of the analysis are as follows:

- (1) The first step involved observing the operation and then flowcharting the process as shown in figure 7-24 below.
- (2) Members of the team then observed other restaurants to find ways of improving the process.
- (3) Once the research was completed, the desired performance was identified and compared to the actual process.
- (4) The team, which involved management, employees, and outside consultants, then developed a new plan for the process.
- (5) This new process was first tried out during slow business hours to ensure the new process ran smoothly.
- (6) Once everyone agreed that the new process was more efficient, then it was implemented.

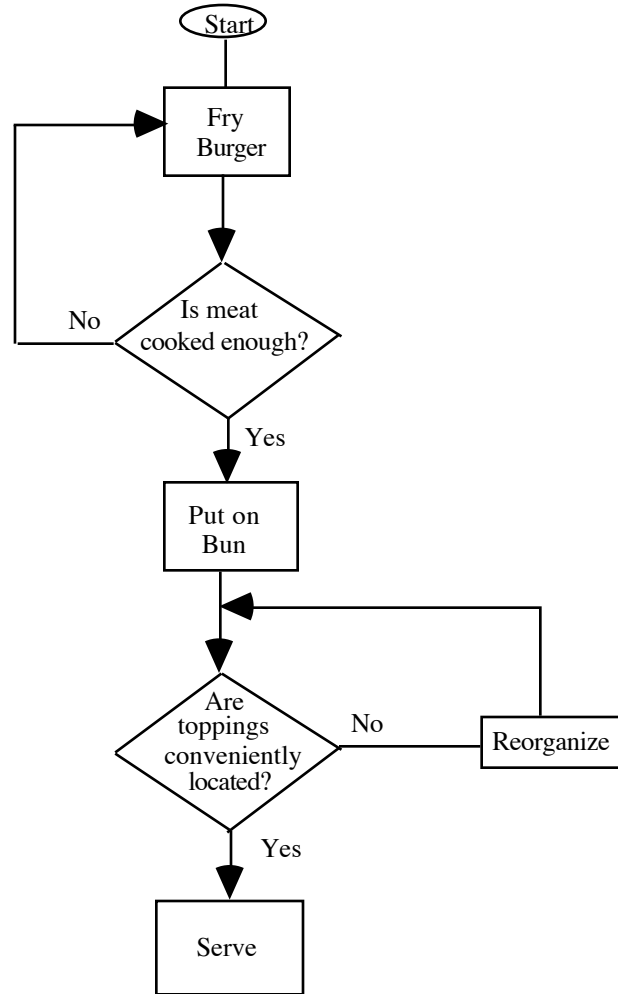

Figure 7-24. WFA example.

### 7.16.5 Advantages

The technique may increase productivity and improve working conditions.

### 7.16.6 Limitations

- (1) The technique requires cooperation between employees and management to be most successful.
- (2) The observed operation may not be fully representative of a “typical” process that would occur without scrutiny.

## REFERENCES

- 7.1 Brocka, B., and M. S.: "Quality Management, Implementing the Best Ideas of the Masters." Business One Irwin, Homewood, IL 60430, 1992.
- 7.2 Camp, R.C.: "Benchmarking, The Search for Industry Best Practices that Lead to Superior Performance." Quality Press, 1989.
- 7.3 Hunt, V.D.: "Quality in America, How to Implement a Competitive Quality Program." Business One Irwin, Homewood, IL 60430, 1992.
- 7.4 Lake, J.G.: "Concurrent/Systems Engineering." Defense Systems Management College, 1992.
- 7.5 "Total Quality Management – Executive Briefing." American Supplier Institute, Dearborn, MI, 1990.
- 7.6 Choppin, J.: "Quality Through People, A Blueprint for Proactive Total Quality Management." IFS Publications, United Kingdom, 1991.
- 7.7 Ott, E.R., and Schilling E.G.: "Process Quality Control." McGraw-Hill Book Company, 1990.
- 7.8 Juran, J.M., Gryna, F.M., Jr., and Bingham, R.S., Jr.: "Quality Control Handbook." McGraw-Hill Book Company, 1974.
- 7.9 Box, G.E.P., Hunter, W.G., and Hunter, J.S.: "Statistics For Engineers." John Wiley and Sons, Inc., 1978.
- 7.10 "Advanced Solid Rocket Motor Ignition Subsystem Assessment." Larry Thomson, Kurt Everhart, Curtis Ballard, Report No. 314-004-93-259, August 1993.
- 7.11 "System Safety Program Requirements." MIL–STD–882C, January 1993.
- 7.12 "A Comprehensive Tool for Planning and Development." M.A. Schubert, Reliability Technology Consultant, Inland Division of General Motors Corporation, Dayton, OH, 1989.
- 7.13 "Prioritization Methodology for Chemical Replacement." W. Cruit, S. Schutzenhofer, B. Goldberg, and K. Everhart, May 1993.
- 7.14 "Introduction to Quality Engineering – Four Day Workshop, Implementation Manual." American Supplier Institute, Dearborn, MI, 1989.
- 7.15 NASA–STD–8070.5A, "Trend Analysis Techniques." October 1990.
- 7.16 Harrington, H.J.: "Business Process Improvement." McGraw-Hill Book Company, TS5156 H338, 1991.

## 8. TREND ANALYSIS TOOLS

Trend analysis, as described in reference 8.1, is a quantitative tool used to identify potentially hazardous conditions and cost savings based on past empirical data. Trend analysis evaluates variations of data to find trends, with the ultimate objective of assessing current status and forecasting future events. Trend analysis can be reactive or proactive. Data examined from past events can uncover a cause of a problem or inefficiency in a product or operation. Also, real-time data can be tracked to detect adverse trends that could indicate an incipient failure or can be used to reduce discrepancies in a product or operation.

Program level trending exchanges data between organizations and correlates trends from the various organizations to find relationships and allows integration of the trend analysis effort with any planned TQM effort (sec. 7), such as SPC (sec. 7.14). It also allows upper level management to forecast problems such as shortages, schedule delays, or failures. Finally, in starting a program level trending effort early in the program, data collection will be more efficient and cost-effective.

The use of trend analysis has several benefits. Among them are:

- (1) Predicting system or process failure or violation of a process limit criterion.
- (2) Indicating that a unit can remain in service longer than anticipated or projecting the service life of a unit.
- (3) Eliminating the need for some hardware inspections.
- (4) Increase cost-effectiveness by reducing variability in a process.

There are different levels of trend analysis parameter criticality based on the degree of the benefit derived from the results of the trend analysis for that parameter. Some parameters have a direct effect on system safety while others will have an impact on cost or timeliness of a process. Criticality levels have an impact on the amount of trending to be performed, the level to which it is to be reported, the data that are to be stored, and the time over which the trending is to be performed. Examples of criteria for levels of requirements are:

- (1) Parameters impacting personnel safety.
- (2) Parameters impacting successful system performance.
- (3) Parameters which could cause failure of a component that would not result in system failure.
- (4) Parameters impacting schedule of the system.
- (5) Parameters impacting delivery schedule of components.
- (6) Parameters impacting cost of manufacturing.

Trending can be used at levels from program management to component and system production and vendors. Upper level management would conduct trending on program level issues, and individual organizations would conduct trending on issues pertinent to that organization at a component/material, subsystem, or system level.

Examples of trending activities are:

- (1) Component-receiving organizations can conduct trending on such things as would indicate the quality of incoming components, materials, and problems of receiving them in proper condition.
- (2) Manufacturing can conduct trending on component and system requirements, and production problems.
- (3) Test, launch, and refurbishment organizations can conduct trending on performance, time to conduct operations, and problems encountered.

Some trending results will be reported to upper level management, engineering, and the customer, while other results would be for local use by the individual organizations.

Five trending analysis techniques will be discussed in this section. Performance trend analysis, discussed in section 8.1, detects a degrading parameter prior to a potential failure as well as predicting future parameter values.

Problem trend analysis, discussed in section 8.2, provides an early indicator of significant issues in other types of trend analysis. Other applications of this analysis are to “examine the frequency of problem occurrence, monitor the progress of problem resolution, uncover recurring problems, and assess the effectiveness of recurrence control.”<sup>8.2</sup>

A technique that provides visibility to determine the current/projected health of the human support element is programmatic trend analysis. This analysis is discussed in section 8.3. A technique that monitors the current health of support systems and forecasts support problems to enable resolution with minimum adverse effect is supportability trend analysis. This analysis is discussed in section 8.4.

Finally, reliability trend analysis is discussed in section 8.5. This technique is similar to performance trend analysis and problem trend analysis. Reliability trend analysis measures reliability degradation or improvement and enables the prediction of a failure so action can be taken to avert the failure.

There can be a high level of overlap for some of these types of trend analysis, depending on individual definitions of performance, reliability, and problems. Since many tools are useful for all types of trending and the trend analysis customer typically looks for known parameters, this overlap is not a problem. Performance, problem, and reliability trend analyses are more directly applicable to the needs of a system engineer, than programmatic or supportability trend analyses. However, the former two types of trend analysis are presented here, since results from these analyses may impact the system for which the system engineer is responsible.

A summary of the advantages and limitations of each tool or methodology discussed in this section is presented in table 8-1.

Table 8-1. Trend analysis tools and methodologies.

Tool or Methodology	Section	Advantages	Limitations
Performance trend analysis	8.1	<ul style="list-style-type: none"> <li>(1) Detects a degrading parameter prior to a potential failure.</li> <li>(2) Predicts future parameter values or estimates the long-term range of values of influential variables.</li> <li>(3) The service life of systems or system elements can be predicted.</li> </ul>	<ul style="list-style-type: none"> <li>(1) Parameter sensors may need to be installed to obtain trending data; this can be costly.</li> <li>(2) The operating state, output, or load, about/ through which a system/subsystem/component fluctuates, often cannot be controlled to achieve consistent trend data. (Data must be statistically stable.)</li> <li>(3) The slope and stability of the data approaching/ departing the recorded data point are not known without using a data buffer.</li> <li>(4) Data are not always easily quantifiable, limiting the usefulness of the technique.</li> </ul>
Problem trend analysis	8.2	<ul style="list-style-type: none"> <li>(1) Provides an early indicator of significant issues in other types of trend analysis.</li> <li>(2) Examines the frequency of problem occurrence, monitors the progress of problem resolution, uncovers recurring problems and assesses the effectiveness of recurrence control.</li> </ul>	Candidate items should be chosen carefully because the analysis can be costly if performed for all potential problem areas.
Programmatic trend analysis	8.3	This technique monitors programmatic posture and provides visibility to determine current/projected health of the human support element.	The data collection process can be extensive because of a potentially large and varied number of sources.
Supportability trend analysis	8.4	This technique monitors the current health of support systems and forecasts support problems to enable resolution with minimum adverse effect.	Determining the extent of analysis and identifying the appropriate parameter variations that must be measured can be difficult.
Reliability trend analysis	8.5	This technique measures reliability degradation or improvement and enables the prediction of failures so action can be taken to avert failure.	Candidate items must be chosen carefully because the analysis can be costly if performed for all potential parameters.

## 8.1 Performance Trend Analysis

### 8.1.1 Description

Performance trend analysis, as described in references 8.1 and 8.2, is a parametric assessment of hardware and software operations to evaluate their status or to anticipate anomalies or possible problems. This assessment not only includes operational performance, such as ballistics of an SRM but also assesses hardware performance, such as insulation and inhibitor systems, the motor case, or the nozzle system. For example, postflight measurements of insulation indicate the performance of the insulation during motor operation. The independent variable in performance trend analysis can be time or sequence. Some performance data, for example, that relating to safety, may be recorded and trended on a real-time basis.

As an example, for an SRM, typical operational performance parameters to be trended could be peak pressure, total impulse, ignition delay, thrust rise-time characteristics, and propellant structural or ballistic properties. Typical hardware performance parameters to be trended could include insulation anomalies, structural factor of safety (calculated from as-built drawings), and seal performance (as measured, i.e., from leak checks).

As described in reference 8.2, data sources for performance trend analysis might include new, refurbished, and repaired component and subassembly acceptance inspection, checkout, and test data for development and verification and production hardware including, but not limited to:

- (1) Alignment data.
- (2) Contamination data.
- (3) Dimensional data.
- (4) Nondestructive test data, e.g., magnetic particle, radiography, penetrant, and ultrasonic data.
- (5) Proof test data, e.g., leak check and hydroproof data.
- (6) Functional or performance data, e.g., quantitative and qualitative data.

### 8.1.2 Application

Performance trend analysis is best applied in phase E but may also be applied in phase D. This analysis can be used to identify certain parameters that will indicate that a system or system element (i.e., subsystem, assembly, subassembly, component and piece-part) is degrading and will potentially fail. These parameters can include, but are not limited to, the following:<sup>8.2</sup>

- (1) Direct measures of degradation, such as wear, erosion, pitting, and delamination.
- (2) Measures of conditions that might introduce degradation, such as pressure anomalies, temperature anomalies, vibration, friction, leakage, and contamination.
- (3) Measures that indicate a shift in performance, such as changes in material properties, calibrations, and electrical resistance.

Attendance to maintenance can help to detect degrading parameters which could lead to failure or delay resulting from an exceedance of criteria.



### 8.1.3 Procedures

The procedures to apply performance trend analysis, adapted from references 8.1 and 8.2, are presented below:

- (1) Identify the elements of the system. Assess those hardware or software system elements to identify items that could cause critical or costly failures. Each element of the system should be considered, i.e., each subsystem, assembly, subassembly, component and piece-part. List these system elements as candidates for performance trend analysis.
- (2) From the list, select which items will be analyzed. Concerns (in terms of risk, safety, cost, availability, or schedule) and expected benefits should be the basis for setting priorities when considering which items to select for performance trend analysis.
- (3) Determine the parameters that characterize the performance of the selected system elements. Select parameters that will indicate performance deterioration of the given system element in a timely manner for corrective actions to be approved by management and implemented. Review the following to identify possible candidate parameters for performance trending:
  - a. FMEA (sec. 3.4)/critical items list (FMEA/CIL).
  - b. Drawings and specifications.
  - c. Previous problem reports.
  - d. Equipment acceptance data.
  - e. Original equipment manufacturer's data.
  - f. Operations manual.
- (4) Establish the criticality of each selected parameter. The parameter criticality should be based on the FMEA/CIL or other criteria that have been preapproved by management. The criticality of the parameter will indicate the magnitude of the impact if an adverse trend is detected and to what level of management that adverse trend is reported.
- (5) Determine if the selected parameters can be quantified with obtainable data. A parameter may be quantified with direct measured data (such as temperature, pressure, force, strain, acceleration, heat flux, etc.) or by calculation involving two or more direct measurements (such as specific impulse for rocket engines or compressor and turbine efficiencies for jet engines). If data are not available, establish a system to acquire the data or drop the item from trend analysis.

The availability of the data—the more available the data are, and assuming statistical stability, the greater the likelihood of successful trending. Ten to twenty data points for a parameter are desirable as a minimum.

- (6) Develop acceptance levels for the parameters. These levels or limits become the basis for determining if a parameter is in control or corrective actions are required. First, determine the boundaries that define the required range for normal operation. These boundaries should be identified for each parameter from a review of vender-supplied data, test or operational data, or specifications or requirement documents. Next, determine action limits that fall within these boundaries in which corrective action will be initiated if the action limits are exceeded.

Care should be taken in choosing the action limits so that (1) variation in normal acceptable operation will not cause the action limits to be exceeded (causing unnecessary expenditure of resources), and (2) corrective actions can be implemented promptly, once the action limit is exceeded but before the boundaries for desired normal operation are exceeded. These action limits should be taken from historical data that represent the same distribution for the parameter as that in which future measurements will be recorded and tracked.

- (7) Analyze the selected parameters for trends. Various statistical and graphical techniques for performing trend analysis can be found in reference 8.3. Use graphical tools to transform raw, measured, or calculated data into usable information. The graphical tools can include scatter plots (sec. 5.1) and control charts (sec. 5.2). Use statistical tools, such as regression analysis (sec. 6.6), to determine the trend line through a given set of performance data. Determine how well the trend line fits the data by using techniques such as  $R^2$  or Chi-Square measure of fit tests. These tests are described in detail in reference 8.3 and statistical textbooks and handbooks. Use the trend line to detect if there is a trend that is approaching or has exceeded the action limits determined in step 6.
- (8) Resolve adverse trends. If an adverse trend is detected, determine the cause of the adverse trend. Perform correlation analyses (sec. 6.3) to determine what other parameters (factors) are contributing to the adverse trend. Once the cause of the adverse trend is identified, propose a remedy to correct the problem before the boundaries for desired normal operation are exceeded. Implement (management approval may be required) the remedy, then trend future performance and assess the effectiveness of the remedy.
- (9) Report the results. To maximize the benefits of the trend analysis effort, the results should be documented and distributed to the appropriate levels of management and functional organizations to ensure corrective actions are implemented in a timely manner once an adverse trend is detected. Typically, these reports should contain the following items (adapted from reference 8.2):
  - a. System element (from step 1).
  - b. Parameter identification (from step 3).
  - c. Criticality (from step 4).
  - d. Data source (from step 5).
  - e. Failure mode as described in the FMEA.
  - f. Baseline changes, if applicable.
  - g. Indication of excluded data, trends, their direction and disposition (adverse or acceptable).
  - h. Corrective action used and its effectiveness, if applicable.
  - i. Need for additional data, if applicable.
  - j. Recommendations, as necessary.
  - k. Applicability to other types of trending.
  - l. Need for additional correlation analysis, if applicable.

### 8.1.4 Example

In a machine shop, the service life of saw blades was studied. The objectives of the study were to determine the expected life of the blades and develop a methodology to determine when special causes were effecting machine performance. Performance trend analysis was performed to address both these questions. Blades are replaced when their performance degrades from 10 to 3 cuts per hour. First, performance data were collected for 30 blades to statistically establish the expected service life and the band for expected normal performance.

The daily average cuts per hour for each blade of the 30 blades were measured and recorded until the 3 cuts-per-hour limit was reached. A linear regression analysis of these data was performed to determine the relationship between the cuts per hour and work days. The variation of the 30 blades was examined for each day of operation. This analysis revealed that the variation grew linearly with time. A band was established from  $\pm 3$  standard deviations from the regression line for each day of operation. The expected service life range for a given blade was expressed as the time range defined by the regression  $\pm 3$  standard deviation band of the regression intercepted the three cuts-per-hour replacement limit.

The lower ( $-3$  standard deviation) limit of the band was defined as the action limit to ensure the machine is operating properly. The daily average cuts per hour is tracked for a blade in operation. When the action limit is exceeded, the machine is examined to determine if there is a special cause that is reducing the blade service life.

The expected band for normal operation and expected service life are illustrated on the performance trend analysis plot presented in figure 8-1. The performance of a given blade that has just reached the end of its service has been tracked on this chart. Note that the action limit is the lower limit of the expected normal operation band.

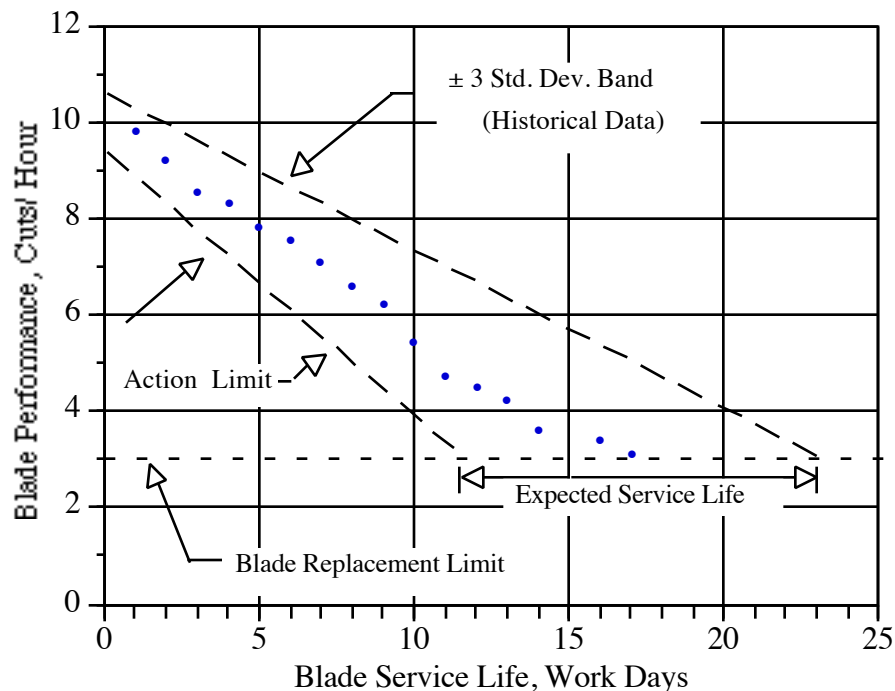

Figure 8-1. Performance trend analysis example.

### 8.1.5 Advantages

- (1) Performance trend analysis can be used to detect a degrading parameter prior to a potential failure.
- (2) This technique can predict future parameter values or estimate the long-term range of values of influential variables.
- (3) The service life of systems or system elements can be predicted.

### 8.1.6 Limitations

- (1) Parameter sensors may need to be installed to obtain trending data—this can be costly.
- (2) The operating state, output, or load, about/through which a system/subsystem/component fluctuates, often cannot be controlled to achieve consistent trend data.
- (3) The slope and stability of the data approaching/departing the recorded data point are not known without using a data buffer.
- (4) Data are not always easily quantifiable, limiting the usefulness of this technique.

### 8.1.7 Bibliography

“ASRM Trend Analysis Requirements Document.” Sverdrup Technology, Inc., Report No. 314-004-91-115, December 1991.

NASA Technical Memorandum 85840, “The Planning and Control of NASA Programs and Resources.”

NMI 1103.39, “Role and Responsibilities – Associate Administrator for Safety and Mission Quality (SMQ).”

NMI 8070.3, “Problem Reporting, Corrective Action, and Trend Analysis Requirements.”

NMI 8621.1, “Mishap Reporting and Investigating.”

NHB 5300.4 (1A-1), “Reliability Program Requirements for Aeronautical and Space System Contractors.”

NHB 8070.TBD, “Significant Problem Reporting System.”

Special Study Z001U61, “Marshall Operations Reliability Trend Analysis Standard.” Sept. 16, 1991.

## **8.2 Problem Trend Analysis**

### 8.2.1 Description

Problem trend analysis, as described in references 8.1 and 8.2, identifies repetitive problems and assesses how often given problems occur. Also, problem trend analysis provides a mechanism to track

progress of problem resolution. Finally, problem trend analysis evaluates organizational proficiency in preventing repetitive problems. Underlying causes can be uncovered when several problems are compared. Problem trend analysis is often an early indicator of significant issues in other types of trend analysis.

There are three basic objectives in problem trend analysis:

- (1) Isolate problems to specific causes and examine the frequency of occurrence of these causes. Problem trending is often initiated on a system level but finished on a component (or lower) level.
- (2) Track problems to determine if occurrence is increasing or decreasing, or if some problems are affecting other parameters.
- (3) Determine if baseline changes or corrective actions increase or decrease the frequency of problem occurrence.

Data sources for problem trend analysis may include, but need not be limited to:

- (1) Failure or problem reporting and corrective action systems such as Problem Reporting and Corrective Action (PRACA).<sup>8.2</sup>
- (2) Discrepancy reports (DR's).
- (3) Problems identified by the other four types of trend analysis.

### 8.2.2 Application

As described in reference 8.2, problem trend analysis is used to identify recurring problems and assesses the progress in resolving these problems and eliminating the recurrence of the problems. This analysis is best applied in phase E but may also be applied in phase D. The main interest in this analysis is locating where the key problems are occurring and the frequency of occurrence. Graphical techniques such as the Pareto analysis (sec. 5.6) are useful in focusing attention and determining where other analyses such as performance trend analysis (sec. 8.1) can be beneficial.

Problem trend analysis provides a historical overview of problems in an easy-to-understand graphical format. This overview assists in decision-making relative to design effectiveness, process, or procedural changes over time. Problem trend analysis can be the first step in the initiation of corrective action to improve system performance.

Basic criteria (from reference 8.2) for the selection of candidate items include:

- (1) Problem frequency (establish from historical problem report databases).
- (2) Criticality (usually determined from FMEA's).
- (3) Engineering judgment (by cognizant personnel familiar with both the hardware and requirements).
- (4) Unique program or project requirements (these requirements indicate more severe consequences than normally associated with a given type of problem).

### 8.2.3 Procedures

Procedures (adapted from reference 8.2) to perform problem trend analysis are as follows :

- (1) Gather pertinent data. Examine the applicable historical data base(s) and acquire the appropriate data. These data bases contain information concerning problem reporting. The data bases are usually maintained by the organization responsible for design and manufacture of a system element or the operational organization that uses the system.

Typically, searches are made for rejection rates from acceptance testing, operation problems, and configuration nonconformance. These searches should be performed for a given time frame. The data bases should be searched for events, operating cycles, hardware identification codes (i.e., system, subsystem, assembly, subassembly, component or piece-part number), failure mode codes from the FMEA, or key words for given hardware failures or failure modes.

- (2) Identify frequency of problems for the system element under consideration. The system element may be the subsystem, assembly, subassembly, component or piece-part. Determine the number of problems (without distinction of failure mode) associated with the system element during given time periods (i.e., days, weeks, months, years, etc.). Next, normalize these unrefined frequency data to the number of operations, cycles, missions, or elements produced during the given time periods. Construct a bar chart (sec. 5.3) for both the unrefined and normalized data. The unrefined data are plotted as a function of occurrences versus time, while the normalized data are plotted as a function of occurrence rates versus time.
- (3) Identify primary causes of the problems. For each system element under consideration, determine the categories of failure modes or causes that induced the problems identified in step 2. Careful review of the problem reports should be performed to ensure that inconsistent wording of problem reports by different authors does not mask the true value of each failure mode or cause. Next, determine the number of occurrences for each failure mode or cause. Construct a Pareto chart (sec. 5.6) of the number of occurrences versus failure modes or causes and identify areas of concern. From the Pareto chart, identify the failure modes or cause of consequence that require further assessment.
- (4) Determine if a trend over time exists for each of the identified failure modes or cause of consequence. Normalize the failure mode or cause as the problems were normalized in step 2 (i.e., normalized by the number of operations, cycles, missions, or elements produced during the given time periods). Construct a bar chart (sec. 5.3) for each failure mode or cause. These bar charts should present the total and normalized number of occurrences versus time. Procedure, process, configuration or design changes and the time of their implementation should be noted on these charts.

Once the bar chart is generated, fit the normalized failure mode or cause occurrences with either a linear, exponential, power, logarithmic, or positive parabolic trend line. Determine the goodness of fit for each trend line model to the data with such statistical methods as the  $R^2$  test. Refer to reference 8.3 or statistical textbooks or handbooks for details in fitting the data with trend lines or testing for goodness of fit.

- (5) Report the results. Prepare a summary assessment of the problem trend analysis, including:
  - a. System element (from step 2).
  - b. Data source, i.e., the historical problem report data base (from step 1).

- c. Failure modes trended and total number of problem reports assessed.
- d. Criticality (from FMEA) of the failure mode(s) and date of last occurrence.
- e. Baseline procedure, process, configuration or design changes, if applicable.
- f. Chief failure mode or cause of consequence.
- g. Indication of trends, their direction and disposition (adverse or acceptable).
- h. Corrective action used and its effectiveness, if applicable.
- i. Need for additional data, if applicable.
- j. Recommendations, as necessary
- k. Applicability to other types of trending.
- l. Need for additional correlation analysis, if applicable.

#### 8.2.4 Example

The monthly rejection rate of wickets exceeded a company's goal of 5 units per 1,000 units produced (0.5 percent) during a 3-mo period last year. A problem trend analysis effort was conducted to understand the reason for the increased rejection rate and to formulate a plan to prevent future excessive rejection rates. The manufacturing reports for a 1-yr production of wickets were reviewed. The results were summarized by month and are presented in figure 8-2(a). Also, the monthly production and rejection rates are shown in figure 8-2(a).

The cause of each rejection was also identified from the manufacturing problem reports and was categorized as being due to human error, inadequate properties of raw materials, production machine malfunctions, or other miscellaneous causes. These results are presented for each month in figure 8-2(b).

The number of rejections and the rejection rates were plotted on a bar chart and the results are presented in figure 8-2(c). The rejection rates were normalized to units produced monthly. As seen on this chart, the rejection rate exceeded the company goal of 0.5 percent during August, September, and October; therefore, this time period became the focus of the analysis.

Note from this figure that the normalized rejection rate data, not the absolute number of rejections, indicate the time period of concern.

A Pareto chart (shown in figure 8-2(d)) was produced for the entire year to establish the significance of each cause for rejection. This chart revealed that human error was the most significant cause for rejection over the entire year period. However, a Pareto chart generated for the 3-mo period of concern, revealed that inadequate material properties was the most significant cause for unit rejection. Comparing the two Pareto charts shows that inadequate material properties was a much more significant problem during the 3-mo period, and that human error was over the entire year. This chart for the 3-mo time period is presented in figure 8-2(e).

The number of rejections and the rejection rates due to inadequate properties of raw materials were plotted on a bar chart and the results are presented in figure 8-2(f). The rejection rates were normalized to units produced monthly. As seen on this chart, the increase in the rejection rate due to inadequate material properties was the driving factor in exceeding of the maximum rejection goal.

Month	Units Produced	Units Rejected	Rejection Rate (Units/1,000 Produced)
Jan.	5,100	12	2.35
Feb.	4,600	21	4.28
Mar.	4,900	16	3.26
Apr.	2,900	12	4.14
May	3,150	13	4.12
Jun.	3,050	10	3.27
Jul.	3,000	12	4.00
Aug.	1,700	14	10.35
Sep.	1,400	14	9.65
Oct.	1,750	15	8.57
Nov.	3,100	9	2.90
Dec.	4,950	21	4.24

(a) History of unit rejections.

Month	Causes for Unit Rejection				Units Rejected
	Human Error	Inadequate Material Properties	Machine Malfunction	Other	
Jan.	6	2	3	1	12
Feb.	10	4	5	2	21
Mar.	8	3	4	1	16
Apr.	6	3	3	0	12
May	6	2	4	1	13
Jun.	5	2	3	0	10
Jul.	6	2	2	2	12
Aug.	3	10	1	0	14
Sep.	3	9	1	1	14
Oct.	4	9	2	0	15
Nov.	5	2	2	0	9
Dec.	10	5	5	1	21
Total	72	53	35	9	169

(b) History of unit reject by cause.

Figure 8-2. Problem trend analysis example—Continued



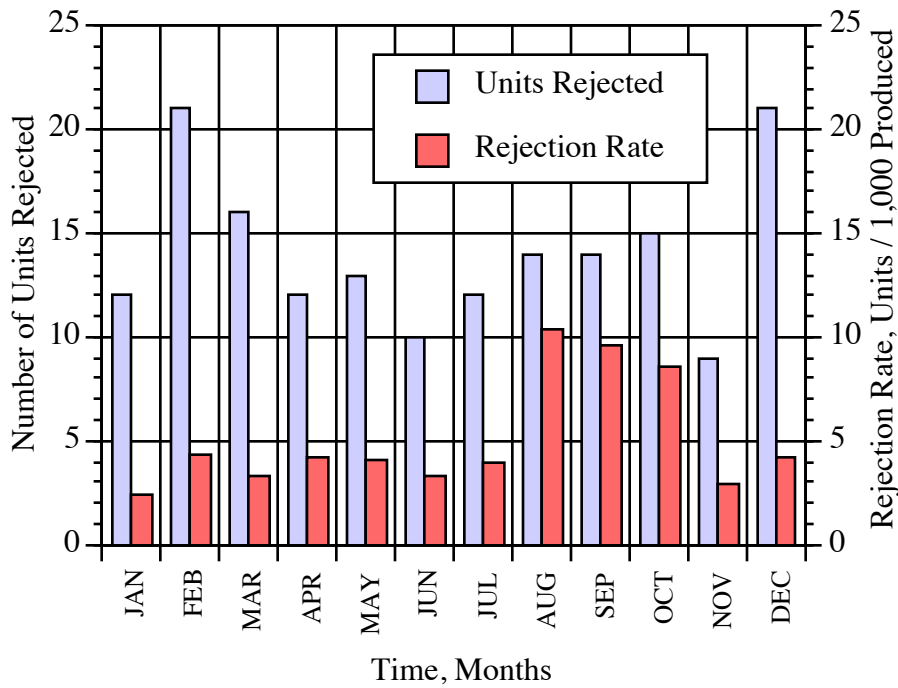

(c) Total unit rejection and rejection rate versus time.

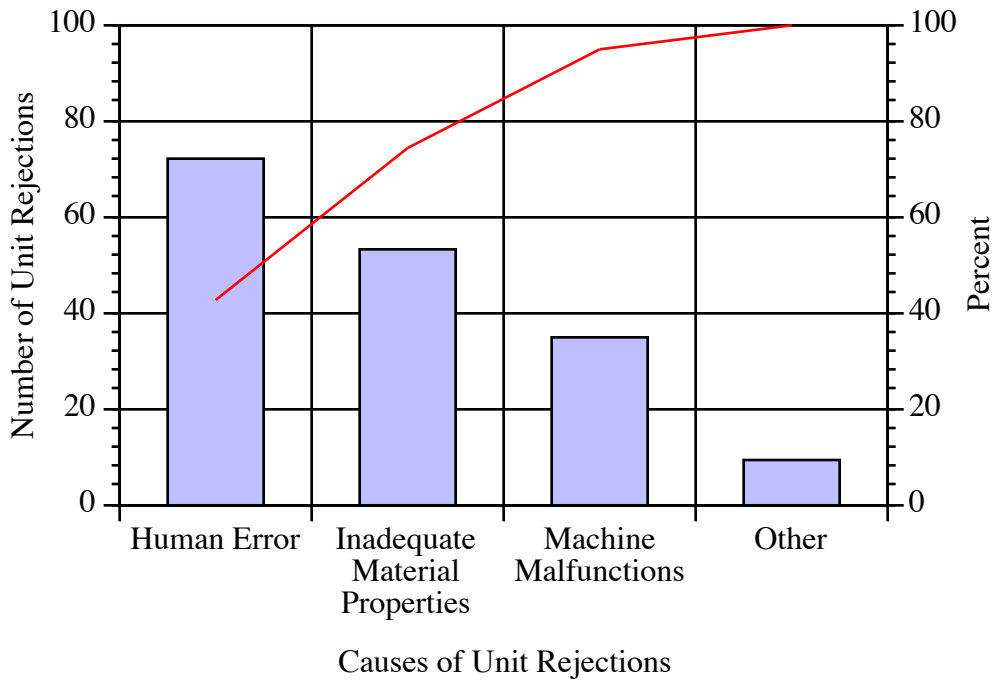

(d) Pareto chart of causes for entire period.

Figure 8-2. Problem trend analysis example—Continued

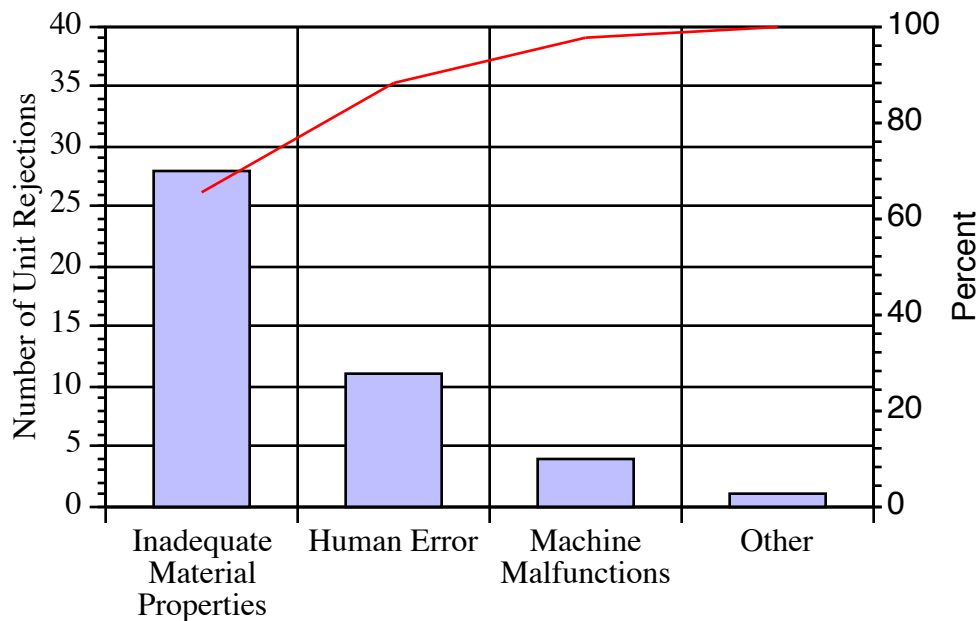

Causes of Unit Rejection  
(for August, September, and October only)

(e) Pareto chart of causes for period of concern.

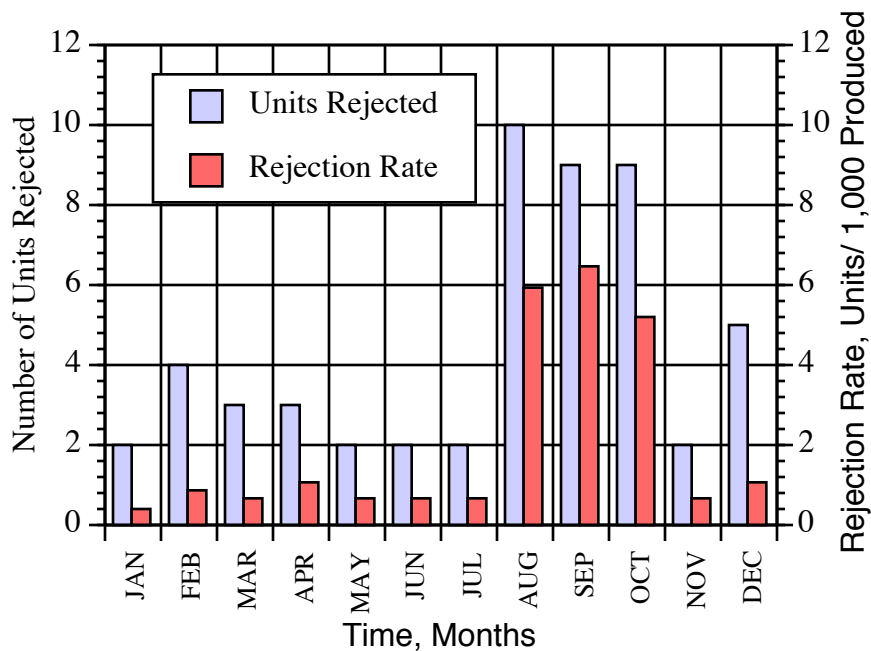

(f) Unit rejection and rejection rate (due to inadequate material properties) versus time.

Figure 8-2. Problem trend analysis example—Continued.

Further analysis showed that a statistically significant larger portion of the units rejected for material properties came from one lot of materials used during the August to October period. This lot met acceptance test criteria, however it was by a narrow margin. To avoid further high rejection rates, the specifications for the raw material were tightened as were the corresponding acceptance tests.

### 8.2.5 Advantages

- (1) Problem trend analysis can provide an early indicator of significant issues in other types of trend analysis.
- (2) This technique examines the frequency of problem occurrence, monitors the progress of problem resolution, uncovers recurring problems, and assesses the effectiveness of recurrence control.

### 8.2.6 Limitations

Candidate items should be chosen carefully because the analysis can be costly or noninformative if performed for all potential problem areas.

### 8.2.7 Bibliography

“ASRM Trend Analysis Requirements Document.” Sverdrup Technology, Inc., Report No. 314-004-91-115, December 1991.

NASA Technical Memorandum 85840, “The Planning and Control of NASA Programs and Resources.”

NHB 5300.4 (1A-1). “Reliability Program Requirements for Aeronautical and Space System Contractors.”

NHB 8070.TBD, “Significant Problem Reporting System.”

NMI 1103.39, “Role and Responsibilities - Associate Administrator for Safety and Mission Quality (SMQ).”

NMI 8070.3, “Problem Reporting, Corrective Action, and Trend Analysis Requirements.”

NMI 8621.1, “Mishap Reporting and Investigating.”

Special Study Z001U61, “Marshall Operations Reliability Trend Analysis Standard.” Sept. 16, 1991.

## **8.3 Programmatic Trend Analysis**

### 8.3.1 Description

Programmatic trend analysis, as described in references 8.1 and 8.2, is concerned with organizational or programmatic issues that may impact safety or system success. These issues include general program health, schedule issues, overtime or sick time usage, production bottlenecks, accidents or equipment damage, supply of critical skills (critical resource scheduling), cost of upkeep versus redesign or procurement, noncompliances, and cost of replacement versus cost of repair.

### 8.3.2 Application

Programmatic trend analysis is best applied in phase E. The objective of programmatic trend analysis is to provide management a status on programmatic issues or early warning of programmatic problems. For example, warning of inappropriate demands on manpower, impending delays, mismatches between demand and available expertise, alerting management on areas needing attention (e.g., damage, injury or accident frequency), supporting program/project improvement changes, support management in monitoring project management performance indicators over time to indicate end-product safety and reliability.

Common candidates for programmatic trend analysis include the following:

- (1) “Manpower strength by speciality, experience, qualification, certification, and grade.”<sup>8.2</sup>
- (2) “Schedule changes/slippages or overages.”<sup>8.2</sup>
- (3) Accident or sick time frequency.
- (4) “Overtime usage versus approved policy.”<sup>8.2</sup>
- (5) Labor problems.
- (6) “Requirement changes, including waivers and deviations.”<sup>8.2</sup>
- (7) “System nonconformances and problems due to human error.”<sup>8.2</sup>
- (8) “Rework expenditures.”<sup>8.2</sup>
- (9) Time/cost considerations for redesign.

Concerns (in terms of risk, safety, cost, availability, or schedule) and expected benefits should be the basis for setting priorities when considering using programmatic trend analysis.<sup>8.2</sup>

Some programmatic trend data will be obtained from other parameters; however, some parameters will be unique to programmatic trends. Trending parameters and supporting data to be recorded and trended that would have a programmatic impact must be selected.

### 8.3.3 Procedures

As described in reference 8.2, apply the following steps to perform the programmatic trend analysis:

- (1) Determine the programmatic parameters to be assessed. Determine which programmatic parameters will be trended. Common parameters that are trended are presented in section 8.3.2. However, the selection of parameters should be determined by the unique needs of the organization or program involved. Maintain a list of parameters for which programmatic data are to be supplied.
- (2) Acquire and compile data for the selected parameters. Data sources (adapted from reference 8.2) for programmatic parameters include, but are not be limited to:

- a. Planned versus actual cost reports (so that number and magnitudes of cost over-runs and underruns can be determined).
  - b. Planned versus actual schedule charts (so that the number and magnitude of schedule delays and accelerations can be determined).
  - c. Quality assurance reports (documenting the number of noncompliances).
  - d. Development and verification status reports (documenting the success or failure in verifying system requirements or specifications).
  - e. Inventory control records (documenting the number of times work was delayed due to unavailable material).
  - f. Facility, equipment, and hardware problem and corrective action reports.
  - g. Acceptance records (documenting number of units produced that were accepted or not accepted by the customer).
  - h. Shipping and receiving logs (including planned versus actual shipping and receiving dates).
  - i. Work authorization and control documents.
  - j. Planned versus actual staff level reports.
  - k. Safety, mishap, or incident reports.
- (3) Ensure the validity of the data. Care should be taken to ensure the data analyzed are accurate and are an appropriate measure for the programmatic parameter being trended.
  - (4) Develop the required analytical techniques and controls (e.g., Pareto charts (sec. 5.6) and histograms (sec. 5.7)). Action limits should be established in which corrective action will be initiated if the action limits are exceeded. Action limits can be set to ensure parameters stay within the operating and administrative policies and procedures, work standards, and goals of the organization.
  - (5) Determine the structure for project data collection, maintenance, and reporting. Identify the organizations and personnel responsible for collecting, maintaining, assessing, and reporting the data.
  - (6) Make data available to program management.
  - (7) Analyze the data for trends. Use control charts (sec. 5.2) to display the historical trends of validated data for the programmatic parameters being measured, along with the realistic action limits established.
  - (8) Resolve adverse trends. When an adverse trend has been identified, conduct an analysis of that trend. Preparing a cause and effect diagram (sec. 7.2) may be useful in identifying the root cause of the adverse trend. Once the cause of the adverse trend is identified, propose a remedy to correct the problem before the boundaries for desired normal operation are exceeded. Implement the remedy (management approval may be required), then trend future performance for the programmatic parameter and assess the effectiveness of the remedy.

- (9) Report the results. The reports should be published at intervals that will allow management to take prompt action to correct problems before they become unmanageable. The reports should contain sufficient details so that management can accurately assess the risk associated with an averse trend. Suggested reporting formats for common programmatic parameters can be found in reference 8.2.

#### 8.3.4 Example

At the start of a new program, candidate parameters were identified for programmatic trend analysis. The list was reviewed by both the project team and management, and trending parameters were selected. Arrangements were made for data to be collected and assessed for each parameter. Action limits were determined from company policies and procedures and program requirements documentation.

The following example illustrates how programmatic trend analysis was applied for a specific programmatic parameter—overtime usage. Review of the company policy revealed that the average overtime rate for a project with more than the equivalent of 100 full-time workers should not exceed 10 percent per month. This particular program average staffing level was 125. An action limit of 8 percent per month maximum overtime rate was established. If this action limit is approached or exceeded, management should be notified and corrective action taken.

The actual overtime rate, expressed in percentage versus month worked, is presented for 1991 in figure 8-3. As seen in this figure, the overtime rate exceeded the action limit in May. Management was notified and overtime usage was reviewed. The cause for the increased rate was due to new negotiated work to be performed. However, the scheduled completion date for the project had remained fixed. Overtime projections revealed that the overtime rate would range from 10 to 13 percent for the remainder of the calendar year.

Work was identified that could be subcontracted. This work was approximately 6 percent of the total project. Management agreed to subcontract the work starting in mid-June. Tracking the overtime usage rate past the time the corrective action was implemented revealed that the fix of the programmatic problem was effective (as shown in fig. 8.3).

#### 8.3.5 Advantages

The programmatic trend analysis technique monitors programmatic posture and provides visibility to determine the current/projected health of the human support element.

#### 8.3.6 Limitations

The data collection process can be extensive because of a potentially large and varied number of sources.

#### 8.3.7 Bibliography

“ASRM Trend Analysis Requirements Document.” Sverdrup Technology, Inc., Report No. 314-004-91-115, December 1991.

NASA Technical Memorandum 85840, “The Planning and Control of NASA Programs and Resources.”

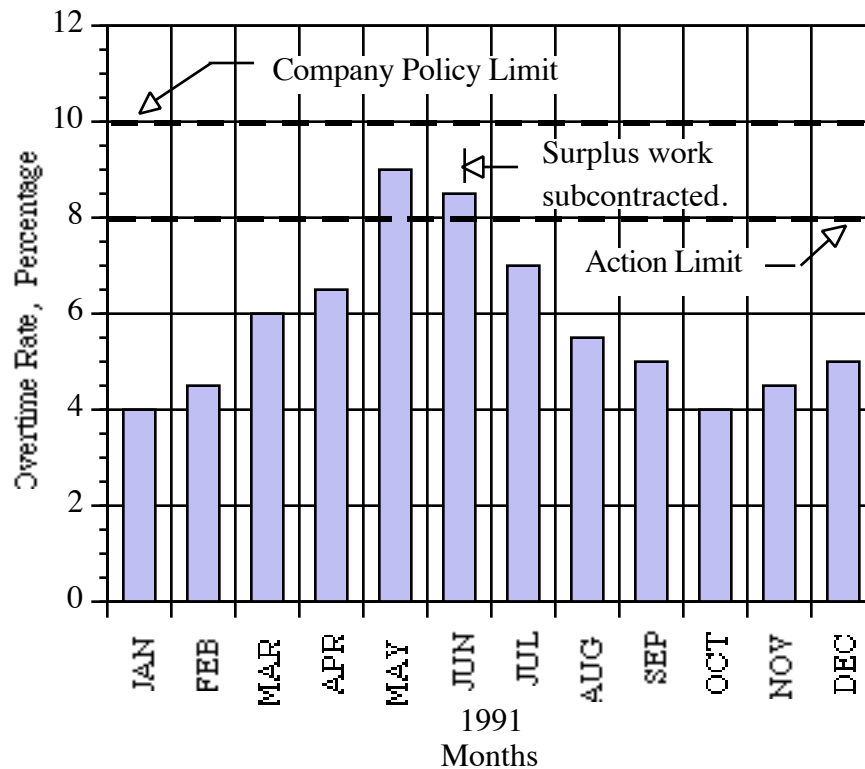

Figure 8-3. Programmatic trend analysis example.

NHB 5300.4 (1A-1), "Reliability Program Requirements for Aeronautical and Space System Contractors."

NHB 8070.TBD, "Significant Problem Reporting System."

NMI 1103.39, "Role and Responsibilities – Associate Administrator for Safety and Mission Quality (SMQ)."

NMI 8070.3, "Problem Reporting, Corrective Action, and Trend Analysis Requirements."

NMI 8621.1, "Mishap Reporting and Investigating."

Special Study Z001U61, "Marshall Operations Reliability Trend Analysis Standard." Sept. 16, 1991.

## 8.4 Supportability Trend Analysis

### 8.4.1 Description

Supportability trend analysis, as described in references 8.1 and 8.2, is performed to evaluate the proficiency of an organization at controlling the logistics factors supporting a program. Logistic concerns likely to be trended are supplies of spare parts, replaceability, frequency of cannibalization, late deliveries,

shortages, maintenance, etc. Typically, data used for supportability trend analysis are not in a form that is readily usable. Processing certain data is labor-intensive or may not be feasible due to contractual considerations. Sometimes indirect or related parameters may be used to indicate supportability.

#### 8.4.2 Application

The supportability trend analysis technique is best applied in phase E. This analysis assesses the effectiveness of logistics factors (extracted from reference 8.2) such as the following:

- (1) Maintenance.
- (2) Supply support.
- (3) Facilities management and maintenance.
- (4) Support personnel and training.
- (5) Packaging, handling, storage, and transportation.
- (6) Technical data support.
- (7) Automated data processing hardware/software support.
- (8) Logistics engineering support.

Supportability trend analysis monitors the current status of the support systems and forecasts the future status in order to resolve problems with minimum adverse effect. The current support systems are analyzed in order to estimate the future requirements of the systems. Also, support elements that can be improved are identified and the effects on the supportability of other program factors are determined.

Another application of supportability trend analysis is to optimize system availability over operating life. This is done by identifying the support elements that can be improved. Also, the effects of system reliability and maintainability on supportability are measured, and areas for improvement are identified.

Candidates used to evaluate system reliability/maintainability/availability support characteristics include the following:<sup>8.2</sup>

- (1) Mean-time-between-failures (MTBF)
- (2) Mean-time-to-repair (MTTR)
- (3) Mean-time-between-repairs (MTBR).

Concerns (in terms of risk, safety, cost, availability, or schedule) and expected benefits should be the basis for setting priorities when considering using supportability trend analysis.<sup>8.2</sup>

Supportability trending parameters should be selected that indicate the effectiveness of the support elements and the maintainability design factors. Operations and support systems should be analyzed, if support degrades, to identify items that could lead to a system failure, schedule delay, or cost increase.



### 8.4.3 Procedures

The procedures (adapted from reference 8.2) to perform supportability trend analysis are as follows:

- (1) Assess the overall operation. Identify parameters that could indicate impending system failure, cost impacts, and schedule slippages if support functions deteriorate.
- (2) Select parameters to be trended. Determine which parameters (identified in step 1) can best be used to evaluate whether support functions are varying at a sufficient rate to require management attention. Special consideration should be given to parameters that predict system safety or success.
- (3) Determine if quantitative data are available and adequately represent these parameters. Supportability parameters may be derived directly from measurements or from calculations involving two or more measurements. If measurement data are not available, develop a system to measure the data or eliminate the parameter from the list to be trended.
- (4) Establish acceptance limits for the selected parameters. These levels or limits become the basis for determining if a parameter is in control or corrective action is required. First, determine the acceptance levels and minimum baselines that define the required level of support for normal operation. Acceptance limits and minimum support baselines should be taken directly from program or project support requirements documentation. These boundaries can also be determined from review of operation, maintenance, and logistics manuals, and design requirements and specifications documents.

Next, determine action limits that fall within these boundaries, for which corrective action will be initiated if the action limits are exceeded. Care should be taken in choosing the action limits so that (1) variation in normal acceptable operation will not cause the action limits to be exceeded (causing unnecessary expenditure of resources), and (2) corrective actions can be implemented promptly, once the action limit is exceeded, but before the boundaries for required support for normal operation are exceeded.

- (5) Gather, measure, or calculate the data to be used to trend the selected supportability parameters. Data sources (extracted from reference 8.2) for supportability trend analysis may include, but need not be limited to:
  - a. Equipment problem reports.
  - b. Work authorization documents.
  - c. Contractual acceptance records.
  - d. Shipping and receiving reports.
  - e. Payment records for maintenance.
  - f. Transportation records.
  - g. Inventory records.
  - h. Issues and turn-in records.
  - i. Training course attendance records.

- j. Technical documentation error reporting.
  - k. Consumable replenishment records.
- (6) Analyze the selected parameters for trends. Various statistical and graphical techniques for performing supportability trend analysis can be found in reference 8.3. Use graphical tools to transform raw, measured, or calculated data into usable information. These graphical tools can include scatter plots (sec. 5.1), bar charts (sec. 5.3), and control charts (sec. 5.2). Use statistical tools, such as regression analysis (sec. 6.6), to determine the trend line through a given set of performance data. Determine how well the trend line fits the data by using techniques such as  $R^2$  or Chi-Square measure of fit tests. These tests are described in detail in reference 8.3 and statistical textbooks and handbooks. Use the trend line to detect if there is a trend that is approaching or has exceeded the action limits established in step 4.
  - (7) Resolve adverse trends. When an adverse trend has been identified, conduct an analysis for that trend. A cause and effect diagram (sec. 7.2) may be useful in identifying the root cause of the adverse trend. Once the cause of the adverse trend is identified, propose a remedy to correct the problem before the boundaries for required support of normal operation are exceeded. Implement the remedy (management approval may be required), then continue to trend the supportability parameter and assess the effectiveness of the remedy.
  - (8) Report the results. The reports should be published at intervals that will allow management to take prompt action to correct support problems before they become unmanageable. The reports should contain sufficient details so that management can accurately assess the risk to normal operation due to an adverse trend. Suggested reporting formats for common supportability parameters can be found in reference 8.2.

#### 8.4.4 Example

The following example illustrates supportability trend analysis for inventory control of a specific spare part. Review of the project support requirements document revealed that at least eight spare parts were always required. To ensure the inventory never reached this level, an action limit of 10 spare parts was established. The inventory level for the parts for 11 months in 1988 and 1989 is presented in figure 8-4. As seen in this figure, the inventory level reached the action level in August 1988. Assessment of the cause for the low inventory level revealed that usage of the spare parts did not increase, however, more parts received from the vendor were being rejected in acceptance tests. The corrective action was to change vendors for the parts. This occurred in September 1988. Tracking the inventory level past the time the corrective action was implemented revealed that the fix to the support problem was effective.

#### 8.4.5 Advantages

Supportability trend analysis monitors the current health of support systems and forecasts support problems to enable resolution with minimum adverse effect.

#### 8.4.6 Limitations

Determining the extent of analysis and identifying the appropriate parameter variations that must be measured can be difficult.

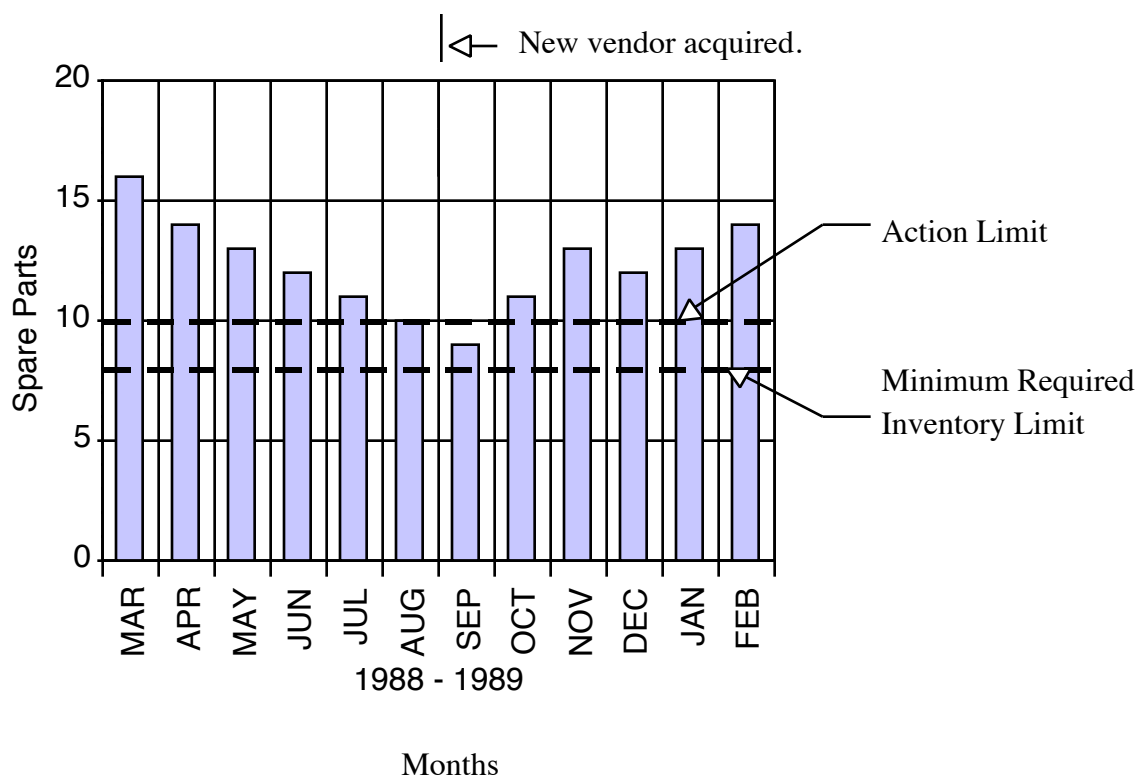

Figure 8-4. Supportability trend analysis example.

#### 8.4.7 Bibliography

“ASRM Trend Analysis Requirements Document.” Sverdrup Technology, Inc., Report No. 314-004-91-115, December 1991.

NASA Technical Memorandum 85840, “The Planning and Control of NASA Programs and Resources.”

NHB 5300.4 (1A-1), “Reliability Program Requirements for Aeronautical and Space System Contractors.”

NHB 8070.TBD, “Significant Problem Reporting System.”

NMI 1103.39, “Role and Responsibilities – Associate Administrator for Safety and Mission Quality (SMQ).”

NMI 8070.3, “Problem Reporting, Corrective Action, and Trend Analysis Requirements.”

NMI 8621.1, “Mishap Reporting and Investigating.”

Special Study Z001U61, “Marshall Operations Reliability Trend Analysis Standard.” Sept. 16, 1991.

## 8.5 Reliability Trend Analysis

### 8.5.1 Description

Reliability trend analysis, as described in reference 8.1, performs a parametric assessment of factors affecting system reliability. The objectives of reliability trend analysis are to measure reliability degradation or improvement, to predict an out-of-line failure, to verify design certification limits, to determine life limits, and to evaluate inspection intervals. Although some parameters will be unique to reliability, many parameters pertaining to reliability trending also pertain to performance or problem trending.

Data sources for reliability trend analysis might include new, refurbished, and repaired component and subassembly acceptance inspection, checkout, and test data for development and verification and production hardware including, but not limited to:

- (1) Alignment data.
- (2) Contamination data.
- (3) Dimensional data.
- (4) Nondestructive test data, e.g., magnetic particle, radiography, penetrant, and ultrasonic data.
- (5) Proof test data, e.g., leak check and hydroproof data.
- (6) Functional or performance data, e.g., quantitative and qualitative data.

### 8.5.2 Application

Reliability trend analysis is best applied in phase E but may also be applied in phase D. Reliability trending parameters should be selected to indicate changes in the reliability of a system and explain their causes. These parameters could also be performance or problem trending parameters or strictly reliability parameters. The criteria for selecting parameters should consider criticality, problem frequency, engineering judgment, etc. as deemed necessary. Trending parameters should be selected, as applicable, for each system, subsystem, or component by:

- (1) For each parameter, reviewing the FMEA/CIL, contract end item specification, limited-life items lists, previous problem reports, original equipment manufacturer's data, equipment acceptance data, operations manuals, etc. to determine if it is necessary or beneficial to perform reliability trending.
- (2) Determining the product life indicators necessary to determine the health of the system, subsystem, or component, e.g., MTBF.
- (3) Determining the failure modes pertinent to the system, subsystem, or component.
- (4) Determining if time/cycle and failure data are available. Typically, at least 10 failures are necessary to perform a reliability trend analysis; however, an action limit can be set to indicate a "failure" data point. At least half of the time/cycle intervals should have an average of at least one "failure" per time period. (For example, if six time intervals of 2 yr are chosen, at least three intervals should have at least two failures.) Design/process change data should be available.

- (5) If necessary data are not available (e.g., failure and time/cycle data), consider the addition of data sensors, obtaining alternate data, changing the parameter, or using engineering judgment for the trend analysis.
- (6) Determining if the parameter concerns reusability/repairability or a one-time failure.

### 8.5.3 Procedures

The only differences between performance and reliability trend analysis are the parameters trended. Therefore, the procedures to perform reliability trend analysis are same as presented in section 8.1.3 for performance trend analysis.

### 8.5.4 Example

This example is a plot of reliability trending where the CSF is plotted for the first 20 flight motors. The lines for the mean  $\pm$  3 standard deviations are based on the motors up to number 50 and give an indication that the later motors have a higher CSF than the first motors.

Also plotted is the minimum CSF allowable by specification (1.5) that shows that this station is well above the requirement. Most stations do not lie this far above the minimum CSF value.

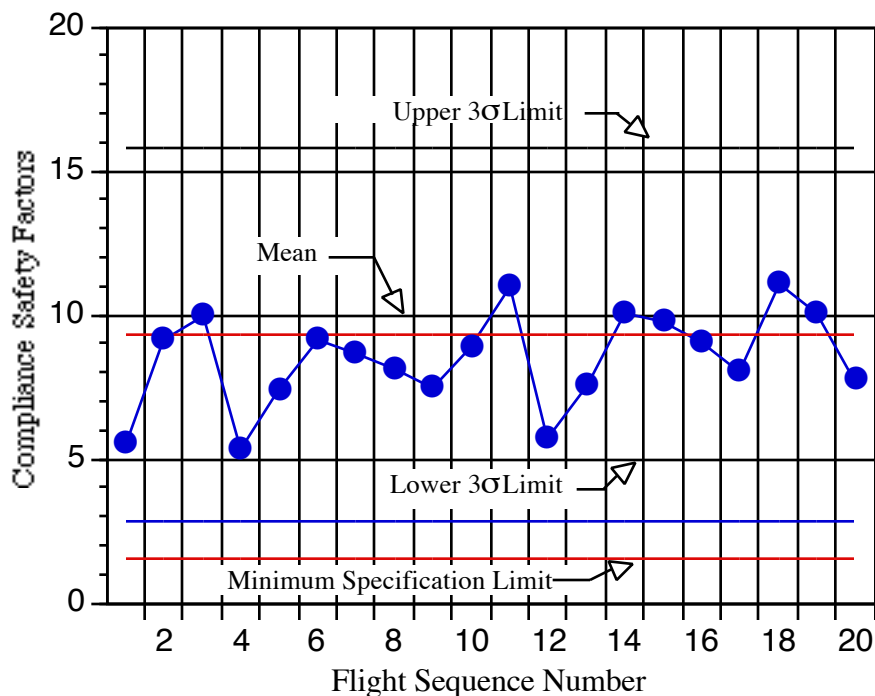

Figure 8-5. Reliability trend analysis example.

### 8.5.5 Advantages

Reliability trend analysis measures reliability degradation or improvement and enables the prediction of possible failures so action can be taken to avert failure.

### 8.5.6 Limitations

Candidate items must be chosen carefully because the analysis can be costly if performed for all potential problem areas.

### 8.5.7 Bibliography

“ASRM Trend Analysis Requirements Document.” Sverdrup Technology, Inc., Report No. 314-004-91-115, December 1991.

NASA Technical Memorandum 85840, “The Planning and Control of NASA Programs and Resources.”

NHB 5300.4 (1A-1), “Reliability Program Requirements for Aeronautical and Space System Contractors.”

NHB 8070.TBD, “Significant Problem Reporting System.”

NMI 1103.39, “Role and Responsibilities – Associate Administrator for Safety and Mission Quality (SMQ).”

NMI 8070.3, “Problem Reporting, Corrective Action, and Trend Analysis Requirements.”

NMI 8621.1, “Mishap Reporting and Investigating.”

Special Study Z001U61, “Marshall Operations Reliability Trend Analysis Standard.” Sept. 16, 1991.

## REFERENCES

- 8.1 Babbitt, N.E., III: "Trend Analysis for Large Solid Rocket Motors." AIAA 92-3357, Sverdrup Technology, Inc., Huntsville, AL, 1992.
- 8.2 NHB 8070.5A, "NASA Trend Analysis and Reporting." Draft, December 1991.
- 8.3 NASA-STD-8070.5A, "Trend Analysis Techniques." NASA System Assessment and Trend Analysis Division, Office of the Associate Administrator for Safety and Mission Quality, October 1990.

**APPENDIX A**  
**TOOL OR METHODOLOGY SUGGESTION FORM**





## Toolbox or Methodology Suggestion Form

<b>Existing</b> <input type="checkbox"/> <b>New</b> <input type="checkbox"/>	<b>Name of Tool/Methodology:</b>
<b>A. Description:</b>	
<b>B. Application:</b>	
<b>C. Procedures:</b>	
<b>D. Example (if applicable)</b>	
<b>E. Advantages:</b>	
<b>F. Limitations:</b>	
<b>G. References:</b>	
<b>Submit To:</b> B. E. Goldberg, Ph.D. Chief: Solid Motor Design Branch George C. Marshall Space Flight Center Marshall Space Flight Center, AL 35812	<b>Submitted By:</b> Name: Address: Telephone:

**Note: Attach Additional Sheets, If Necessary**

**APPENDIX B**  
**CASE STUDY:**  
**TRIALS AND TRIBULATIONS OF USING SYSTEM ENGINEERING TOOLS**



## CASE STUDY:

### TRIALS AND TRIBULATIONS OF USING SYSTEM ENGINEERING TECHNIQUES

#### The Assignment

Charlie Smith came in to work early Monday morning. And why not? He was excited! He'd just completed a course in System Engineering where they'd shown him all these "techniques" to make his job easier and less subjective. He'd known about some of the techniques. But he wished he'd had the course about 10 years ago—back when he was just starting as a systems engineer. Well, no matter... Today his boss was going to give him a new assignment, and he'd show all of them his newly-found proficiency with the toolbox. This should be easy...

His boss, Mr. Jones came in about 9. It had been hard on Charlie, waiting that long, but he had used the extra time to read his mail, do a little filing, return his phone messages, and write a report. "Hmmm," he thought, "maybe I came in a little too early..."

Aw well, his boss, Jones, had finally made it. Without exchanging pleasantries, Jones gave him a package—"It's your new assignment, but I don't see how you'll do it. The boss wants everything measurable this time—wants to see how things were decided. Good luck—let me know how it goes." With that, Jones left and Smith tore open the package. "A Hands-on Science Museum display suitable for grades K–12, for the Museum's Chemistry Section." Since Smith was a designer of aerospace hardware, he really wasn't sure about this one. What was he supposed to do? What were the ground-rules? Why get this assignment now, just when he was prepared to use all his training to really produce real hardware, not a vague ill-defined thing like this? Smith decided to talk to his boss—this day wasn't getting any better.

Jones' secretary let him know that Jones was gone for the day. He went back to his desk and found a message from the System Engineering class instructor, Ms. Doe. Puzzled, he called her back, but he was so preoccupied with his new task that he started right in talking about it.

"Can you imagine, I thought I'd get to use those techniques to build something. Guess I'll have to finish this task first though. I think I'll just pick something and press on. I don't think the tools apply here, you know? It's not really defined enough and I don't really think the data even could exist, much less that I could get it. I mean, with a problem like this, there really aren't any 'data' to look at anyway!" Charlie was getting himself kind of worked up.

Ms. Doe (Jane to her friends) almost laughed when she replied, "Buck (Smith's boss—no one knew his real name) asked me to call you because he thought you might react this way. Now remember what we talked about in class. Every problem seems this way at first. The techniques really do add value, as long as you think about why you're using them. Tell you what, why don't you look through the phase A group, think about it, and we can talk it through tomorrow?"

### Phase A—If at First You Don't Succeed...

After calming down a bit, Smith agreed that this was worth a try, but he really didn't think it would work. He hung up, asked his secretary to hold his calls (he liked doing that) and brought out his matrix. "Let's see... trade studies, cost-versus-benefit studies, risk assessment matrix..." No wait, that risk assessment thing was a secondary for phase A. He carefully crossed it off his list and continued "benchmarking, cause and effect, checklists, and quality function deployment," all no good, they were secondaries. That left brainstorming, Delphi technique, and nominal group technique. Well, that made five techniques for him to use. Too bad about quality function deployment—he really liked that one, but he'd follow the priorities Ms. Doe had set—after all, she ought to know.

Smith wanted to be systematic, so he placed the five techniques down in alphabetical order on a piece of paper:

Brainstorming  
 Cost-versus-benefit studies  
 Delphi technique  
 Nominal group technique  
 Trade studies.

He'd start with brainstorming first. Jones was about to ask his secretary to call together his group when he started feeling a little silly about asking for their help. After all, he wasn't sure himself what he wanted and didn't want to look stupid to his employees. "If only this assignment had been better..." he thought. Anyway, (he just wanted to get this done!) he began to brainstorm by himself.

About an hour later he decided it wasn't going very well. He had been to museums like the one described in his project, and he was a chemical engineer by trade—but so far he just had a page listing of potential chemistry-related topics:

- (A) Types of Matter:
  - Solid – materials
  - Liquid
  - Gas
  - Plasma
- (B) Types of materials:
  - Metal
  - Ceramic
  - Polymer
  - Glass
- (C) Building blocks for materials
  - Largest building blocks for materials
    - Molecules
      - Macromolecules, molecules
  - Smaller building blocks for materials
    - Atoms
      - Electrons
      - Neutrons
      - Protons
    - Subatomic particles
      - Quarks, etc.

- (D) Chemistry
- (E) Designing Materials.

He didn't know what kind of exhibit this might make, and brainstorming wasn't going well. He remembered from the class that brainstorming was best performed in a group, but he thought again about looking foolish. Well, maybe he'd try the next technique—let's see, that was cost-versus-benefit studies.

There was clearly no way to do cost-versus-benefit until he figured out what exhibit he was going to build. He remembered from the class that that technique required data, and he didn't have any. He decided not to waste any more time on cost-versus-benefit—he'd be well prepared to argue with Jane in the morning.

The next two methods, Delphi technique and nominal group technique, fell to similar fates. He wasn't really familiar with them. She must have taught them when he was out, checking in with his office. That was OK because trade studies, the final technique, was one he liked and had used before. Smith began by asking himself what the desirable features of a hands-on museum science exhibit for chemistry were. He prepared a listing.

Features:

- (1) Should be fun as well as educational.
- (2) Should accommodate crowds—not just one person (or if one person, should have pretty good throughput).
- (3) Should be sturdy.
- (4) Should have to do with chemistry (he'd almost forgotten that one!).
- (5) Should fit in a space of...? (he'd have to find out).
- (6) Must be ready by...? (he'd have to find out).
- (7) Must cost no more than...? (he'd have to find out).
- (8) Should be interesting to ages 5 through 18.
- (9) Should have minimal consumables (he knew, from experience, that consumables could destroy a budget).

After writing down these features, Smith realized that features 1 and 8 were kind of motherhood statements, so he took another cut at figuring what he meant by these:

- (1) Should be fun as well as educational.

What makes things fun for kids?

- a. It should involve activity, not passive participation (nothing that the kids just watch). The younger children might have more activity (crawling, climbing, jumping, running etc.) than the older ones.

- b. It might involve winning or high scores or a competition of some sort.
- c. It might involve their making something—visible accomplishment was usually fun.
- d. It could involve testing of their physical or cognitive powers, but should have a black/white answer.
- e. It should not be perceived as childish—must be something an adult would do—don't insult the kids!!!
- f. Moving parts were good—he might want to stay away from solely computerized stuff.
- g. High tech was good, maybe having to do with exploration or environmental themes—tie it to something they knew something about.
- h. If he wanted to get them to do it again and again, it should be something where they might measure improvement, or at least get a different result with a different effort or problem.

Smith sat back, well pleased with this listing. He realized that feature 8 was pretty well covered by his current list and decided not to work on it separately. He wanted a little refresher on the trade study methodology before he went on, so he pulled out his toolbox. Let's see... page 2-3 (section 2.1.3) said to "*Define the mission objective and requirements for the system under consideration.*" All right, he'd done that, now what? "*Identify credible alternative candidates for the system under consideration*"—that's what the toolbox said, but how could he do that when he didn't know what he was building? This toolbox thing wasn't as helpful as he thought. Smith packed up for the day and headed home—tomorrow he was going to have a serious talk with Jane. She clearly hadn't taught this stuff right and anyway, why was Buck calling her about his new assignment, and why couldn't it have been a better one, and... Oh well, he'd save all that for tomorrow.

### **Phase A—...Try, Try Again**

It was a bleak, rainy Tuesday morning. Smith's brooding sleep had been interrupted often by the sharp concussions of thunderstorms. He was going to be ready for Jane Doe! He arrived at work and pulled together his files. His secretary had managed to get some additional information on the science exhibit—the space allowable was approximately 3,000 ft<sup>2</sup>, and his timeframe was approximately 18 months until, it, the museum opened. She had left a note saying that there was still no hard data on his budget but it would likely be on the order of \$400,000. Well, that was something anyway. He checked his calendar and found that Jane Doe would be there in about 15 minutes. He used the time to prepare himself.

Jane arrived on time, wet, and most infuriating of all, cheerful. "So how did it go yesterday?"

Smith began, in a controlled but bitter tone: "Poorly. The tools didn't work very well—there isn't enough data. I went systematically by your procedure—which by the way eliminated some things I thought would be very useful—and I don't think I've made any real progress. Another thing..."



Jane interrupted him here, with that now-very-annoying laugh, “Slow down, slow down, let’s take it one thing at a time. I’ve got all morning, and I think we can make this work. If not, I’ll talk to Buck about it. Deal?”

Smith couldn’t say “no” to that. He figured with just one morning’s effort he’d be able to show Jane that this wasn’t going to work—then it would be someone else’s problem. “Deal.”

They sat down at Smith’s desk. He asked his secretary to hold all calls. (He really liked doing that.)

Smith showed Jane the results of his technique downselection—the alphabetized listing he’d taken from the course toolbox. Jane began, “Charlie, you have to remember, the matrix on page 1-7 is just a guide. You didn’t have to use all of those techniques that were marked priority 1, or ignore the priority 2’s and the unmarked items for that matter. But, since that’s how you started, how did it go?” Jane wasn’t wasting any time.

Smith told her of his difficulties in brainstorming and his concern for calling a team together before he had anything planned out. She acknowledged that this was one of the shortcomings of the brainstorming technique, and she understood—but didn’t seem to agree with—his reluctance to pull a team together. She didn’t want to talk about cost-versus-benefit—she agreed that it wasn’t yet appropriate and congratulated Smith on not trying to force-fit the technique to an inappropriate application. This was not what Smith had expected. They skipped quickly over the next two techniques. She explained they were sort of variations on brainstorming anyway, and got right to his trade study. Smith was quite confident of his knowledge of this technique and felt secure that he could show Jane once and for all that this project was just inappropriate for his newly mastered skills.

Jane read his nine features without comment. She then looked at his breakout for feature 1 and frowned a bit. Smith didn’t want to lose his opportunity (she was turning out to be pretty hard to corner). And he didn’t like that frown one bit. As soon as she looked up he let her have it. “You see, I followed the guideline for trade studies—and by the way, I’ve been using them for many years—and couldn’t get past the second step. How do I know what specifics to trade when I don’t have any specifics? And how can I develop any specifics without data? I just don’t see how this thing is supposed to work!”

Jane’s response surprised Charlie. “These techniques are only to be used where they can help, and you’re the only one who can decide where that is. They don’t replace data. In fact, many of them may highlight where data are required, or just how much you don’t know. But, with your specific problem, I have a few questions. I would have thought things like safety and access for handicapped would be high-priority features. Also, what about education—you’ve analyzed some things that clarify fun but what are the specific educational aspects that you’d like to focus on? I think a focus on that might help a lot.”

Charlie knew that throughout the class she’d discussed using the toolbox as a guideline, and that it wasn’t necessary to use each technique. He just hadn’t trusted his own knowledge of the toolbox well enough to select against the toolbox guidance—cookbooks and go-bys were a lot easier. OK, he’d give her that one. That bit about safety and handicapped access—those were good and he added them to his listing as features 10 and 11, respectively. As for the educational aspects, that was a great observation. Together they began to make up a listing. It didn’t go very well at first, so they called in Dalton from the Applied Chemistry department. After about an hour, they had a listing for the top 15 educational areas that they wished to focus on:

## Educational Areas:

- (1) Demonstrate units of mass, length, volume, temperature etc.
- (2) Demonstrate intrinsic (color, viscosity, melting point, hardness, density...) versus extrinsic properties (size, shape temperature...). Note intrinsic properties are also known as physical properties.
- (3) Demonstrate chemical properties (the tendency of the substance to change, through interactions with other substances or singly).
- (4) Demonstrate chemical change (new substance is formed) vs. physical change—include exothermic and endothermic changes.
- (5) Demonstrate elements, compounds, mixtures, and solutions.
- (6) Demonstrate the states of matter: solid, liquid, gas, plasma.
- (7) Demonstrate the laws of conservation of mass and energy.
- (8) Provide a feel for Avogadro's number.
- (9) Demonstrate crystalline nature of many solids.
- (10) Demonstrate the nature of polymer chains.
- (11) Demonstrate the nature of metals and semiconductor materials.
- (12) Demonstrate the principles of catalysis.
- (13) Demonstrate the principles of combustion.
- (14) Demonstrate the special nature of organic chemistry.
- (15) Demonstrate the standard and quantum theory for the atom.

Smith knew from experience that the next thing to do was to combine these with the features listing and see which areas were likely to make exhibits and which might combine, etc. But this sounded like a combination of brainstorming and trade studies and checklist all twisted together. He asked Jane if that was all right. She explained that there was no problem, as long as what they did was documented and reasonably systematic. Charlie felt more like he had while in class—he was starting to get the hang of this, again. They decided to brainstorm potential exhibits for each of the 15 specific educational areas, and then use the features as a checklist to see if they were satisfied.

Charlie rewrote the features, renumbering and eliminating items, as appropriate:

- (1) Should accommodate crowds—not just one person (or, if one person, should have pretty good throughput).
- (2) Should be sturdy.

- (3) Must be ready in 18 mo.
- (4) Should be interesting to ages 5 through 18.
- (5) Should have minimal consumables (he knew, from experience, that consumables could destroy a budget).
- (6) It should involve activity, not passive participation (nothing that the kids just watched). The younger children might have more activity (crawling, climbing, jumping, running etc.) than the older ones.
- (7) It might involve winning or high scores or a competition of some sort.
- (8) It might involve their making something—visible accomplishment was usually fun.
- (9) It could involve testing of their physical or cognitive powers but should have a black/white answer.
- (10) It should not be perceived as childish—must be something an adult would do—don't insult the kids!!!
- (11) Moving parts were good—he might want to stay away from solely computerized stuff.
- (12) High tech was good, maybe having to do with exploration or environmental themes—tie it to something they knew something about.
- (13) If he wanted to get them to do it again and again, it should be something where they might measure improvement, or at least get a different result with a different effort or problem.
- (14) Must be safe.
- (15) Should be handicapped-accessible.

He then rewrote the educational goals, indexing them by lettering them to avoid confusion with the numbered features list:

- a. Demonstrate units of mass, length, volume, temperature, etc.
- b. Demonstrate intrinsic (color, viscosity, melting point, hardness, density...) versus extrinsic properties (size, shape, temperature...). Note intrinsic properties are also known as physical properties.
- c. Demonstrate chemical properties (the tendency of the substance to change, through interactions with other substances or singly).
- d. Demonstrate chemical change (new substance is formed) versus physical change—include exothermic and endothermic changes.
- e. Demonstrate elements, compounds, mixtures, and solutions.

- f. Demonstrate the states of matter: solid, liquid, gas, plasma.
- g. Demonstrate the laws of conservation of mass and energy.
- h. Provide a feel for Avogadro's number.
- i. Demonstrate crystalline nature of many solids.
- j. Demonstrate the nature of polymer chains.
- k. Demonstrate the nature of metals and semiconductor materials.
- l. Demonstrate the principles of catalysis.
- m. Demonstrate the principles of combustion.
- n. Demonstrate the special nature of organic chemistry.
- o. Demonstrate the standard and quantum theory for the atom.

### **Phase B—Starting to Have a Ball**

Applied Chemist Dalton suggested that they divide the educational goals among several people. Charlie agreed, and decided to work the problem with product development teams. He quickly formed several teams and parcelled out the work. That took some explanations! He'd selected Dalton and Jane for members of his team, along with design artist Mike Angelo, and a marketing executive who worked their company's precollege outreach efforts, Hewitt Wissard. Their task was to develop exhibits for items h, j and k. Jane facilitated the brainstorming session, and by lunchtime they had several concepts developed for each of the educational areas. Charlie copied the concept suggestions down from the yellow stickies they'd used in brainstorming:

#### **Provide a feel for Avogadro's number (item h)**

- (1) Build a "ball pit" where the number of balls was some percentage of Avogadro's number and smaller kids could play. (Hewitt had seen something like this at a pizza place and his daughter liked it a lot.)
- (2) Have a sugar bed filled with grains of sugar that were some percentage of Avogadro's number. This could also be used for experiments (of some sort) and for microscopy when discussing the crystal educational area. Maybe used for eating, too.
- (3) Develop some kind of strength-test thing where kids could compete to get close to Avogadro's Number on a scale or something. (Jane really wasn't a scientist, but in brainstorming, everyone's input could be important).

### **Demonstrate the nature of polymer chains (item j)**

- (1) Have microscopes set up to look at polymer crystals.
- (2) Have a sort of maze set up that was partially amorphous and partially crystalline, like some polymers are. Let the kids walk through it.

### **Demonstrate the nature of metals and semiconductor materials (item k)**

- (1) Have a large blast furnace that the kids could use to heat-treat metals, and then measure the resultant properties using an Instron tester. Also have water, oil, and salt quenching baths.
- (2) Set up something where they could provide various amounts of dopant to semiconductor crystals, and then measure the resistance etc.
- (3) Have a display showing the crystal structure and how semiconductors and metals work (electrically).
- (4) Have polishing wheels set up with microscopes so they could polish specimens and look at grain structure and stuff.

They were far from done, but it was a good start. When Jane asked Charlie if he still wanted her to talk to Buck, he was surprised. He'd forgotten the deal during the long morning's work. "No thanks, I admit we're making pretty good progress. I guess we might even start some phase B work this afternoon, huh?"

"Sure," replied Jane, "but you're on your own for a while. I've got appointments for the next couple of days. I think you'll do fine, and if you run into problems, I'll be back Thursday afternoon. OK?"

"Not quite," said Charlie with his own laugh, "I'll see you Friday morning for a team meeting. OK?"

"OK," laughed Jane, and they all went out to lunch.

Friday came, and Charlie was impressed with the work they had accomplished. After several revisions, they had centered on working on the Avogadro's number thing, the one with the "ball pit." The decision had come after long discussion, and an aborted attempt to perform a weighted average trade study to help quantify the results and the decision-making process. When Jane came in, Charlie (and the rest of the group) was eager to find out what they had done wrong in using the trade study methodology — although Charlie wasn't interested in arguing this time. He was kind of looking forward to working with Jane again. They showed Jane the brief attempt at a trade study that they had formulated:

<u>Item</u>	<u>Criteria Attribute</u>	<u>Weight Factor</u>
1	Avogadro's number (H)	30
2	Fun (4,6,7,8,9,10,11,12)	30
3	Cost (5)	25
4	Safe (14)	10
5	Variable outcome (13)	5

Charlie explained that the letter and numbers in parenthesis referred back to the specific feature and the educational goal delineations they had previously produced. He was pleased with this, as he thought it quite sensible to have tied the criteria attributes to the required features/goals that they had agreed upon. Jane agreed that their approach did represent a very logical progression, but Charlie saw her half smile again. By now he knew that meant they had made an error, and she had spotted it.

"Go on," was all Jane said.

They let Jane know that they had spent a good deal of time discussing the weighting criteria; it represented a group consensus. They then showed her the estimates for each alternative relative to each criteria attribute. They had used the TQM techniques of ranking each of the qualitative items as 1, 5, or 9 to allow separation of results. These rankings, too, were consensus:

<u>Item</u>	<u>Criteria Attribute</u>	<u>Weight Factor</u>	<u>Measure of Effectiveness</u>	<u>Alt 1</u>	<u>Alt 2</u>	<u>Alt 3</u>
1	Avogadro's number	30	Obvious	9	9	9
2	Fun	30	See features	9	9	9
3	Cost	25	ROM estimate	9	9	5
4	Safe	10	Standard stuff		9	9
5	Variable outcome	05	Obvious	9	9	9

They hadn't bothered to calculate the scores or weighted scores. It was obvious that it would come out a wash.

Jane was wearing a large smile now. She said to Charlie, "I think you know where the problem was, but I don't think you recognize the value of what you did! Let's start with the problem. Tell us why you think it didn't work."

Charlie was again caught off guard—he wished she’d stop doing that—but he answered her question. “I don’t think our designs were well formulated enough to be able to evaluate and score. I don’t think we did a very good job on defining quantitative, objective criteria attributes. But for this type of effort, I’m not sure how to do any better. So how can you use a trade study then, when you’re at this stage of a design? Why was it one of the recommended tools?”

Jane’s eyes glittered with her smile as she began, “You’re right about the criteria attributes. One way might have been to simply count the features (an example: How many of the features defining fun were incorporated under each alternate?) and quantify how many the alternate would have met. But that wouldn’t have solved your fundamental problem. You’re right, the designs really weren’t mature enough for this type of study to give a clear selection. To evaluate ‘Safe,’ a PHA would really be required, which means you have to have at least a preliminary design. To evaluate ‘Fun’ and ‘Cost,’ the same level of maturity is also necessary. But, what I don’t think you’ve realized is by performing this study, you were able to identify that. At this stage of design maturity, no concepts were inappropriate. The fact that nothing washed out gave you a valuable answer, and let you choose based on ‘gut feel’—what’s often called ‘engineering’ or ‘programmatic judgement.’ Further, you elected to quantify your qualitative feel for the alternate by using the 1,5,9 technique. I think you guys did just great! You wouldn’t have tried to be specific about why you had selected one idea to pursue if you hadn’t had these techniques—you knew intuitively that there weren’t enough data to use appropriate criteria. These techniques won’t let you do things that can’t otherwise be accomplished. They’re just an aid. And I think you did great. When it wasn’t helping, you tried something else. Which one did you wind up selecting, anyway?”

“Alternate 1- the ball pit,” replied Charlie. “Now I thought we might flowchart the effort required for phase B to figure out where we’re going with this. You know—the plan-your-work and then work-your-plan kind of stuff.”

After some long discussions over the blank page that they were trying to use to do a flowchart, Jane suggested that a good way to get started might be to flowchart what they had already done. Although it seemingly added nothing to their completed tasks, she noted it was often easier to add to something, and even easier to edit or change something, than it was to create it in the first place. Starting the flowchart with the efforts they had already accomplished would give them a base to add upon, rather than the now-beginning-to-be-annoying blank page. They agreed and by the end of the day the group had produced a reasonable flowchart (see figure B-1.) Much of the day had been spent on trying to define which tools would be used. This time they only used the toolbox as a guide and kept asking, “Will this tool help me? Do I need it...?” Their flowchart represented their choices—to their surprise it also provided some insights to the design process.

Many of the phase A decisions were management/programmatic-type decisions that held significant consequences for the remainder of the effort. It was also true that most of the data required to support credible cost-versus-benefit or risk-versus-benefit trade studies did not exist at this stage. Charlie began to hold an even greater appreciation for the toolbox—not so much for the major type decisions, but for the potential to reveal the more subtle ramifications of decisions that might otherwise go unnoted. He spoke his thoughts to the group, noting that these subtleties were particularly critical at the beginning of a project. He received the typical reaction by a group to someone who speaks the obvious—they laughed.

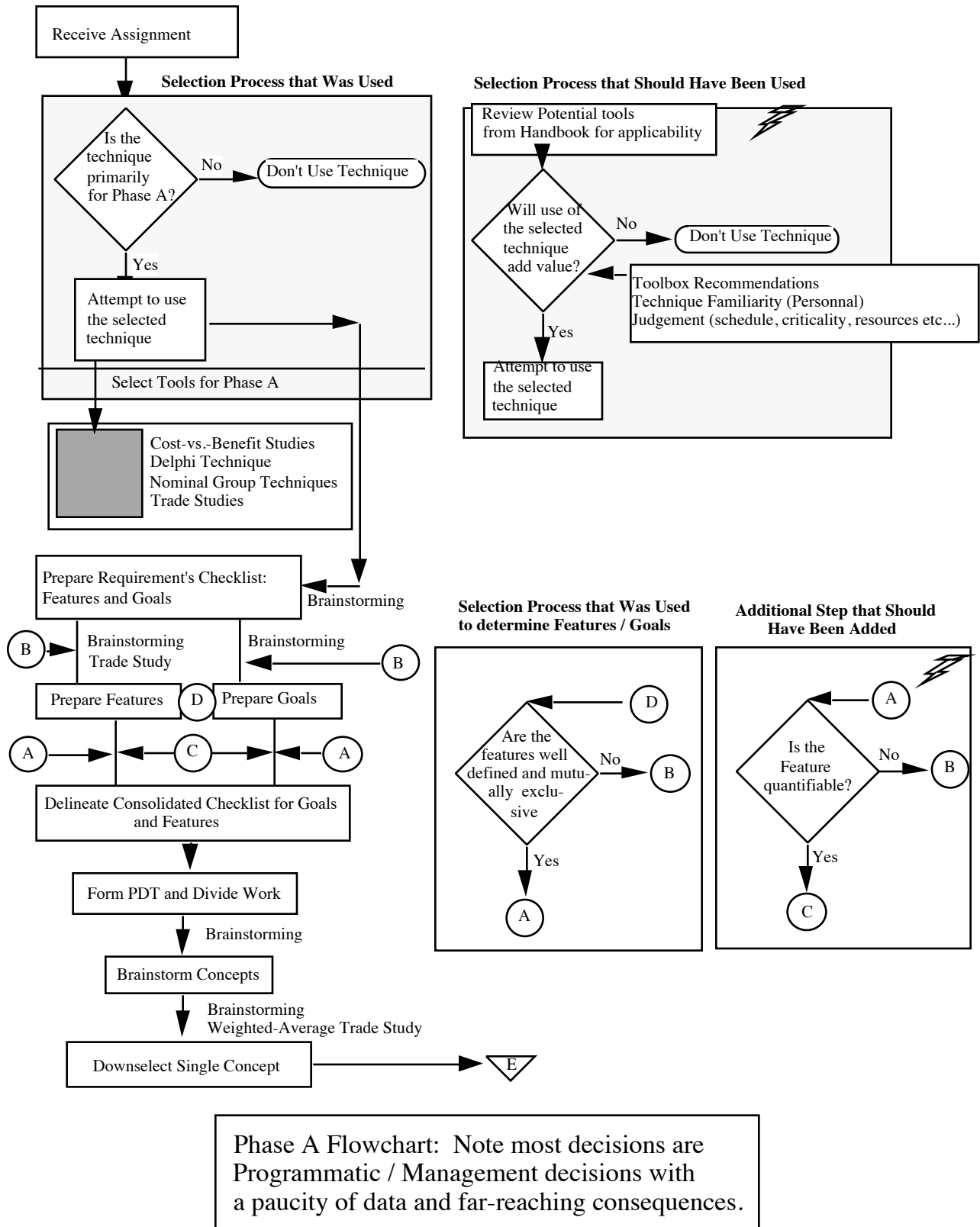

(a) Phase A.  
Figure B-1. Flowchart—Continued



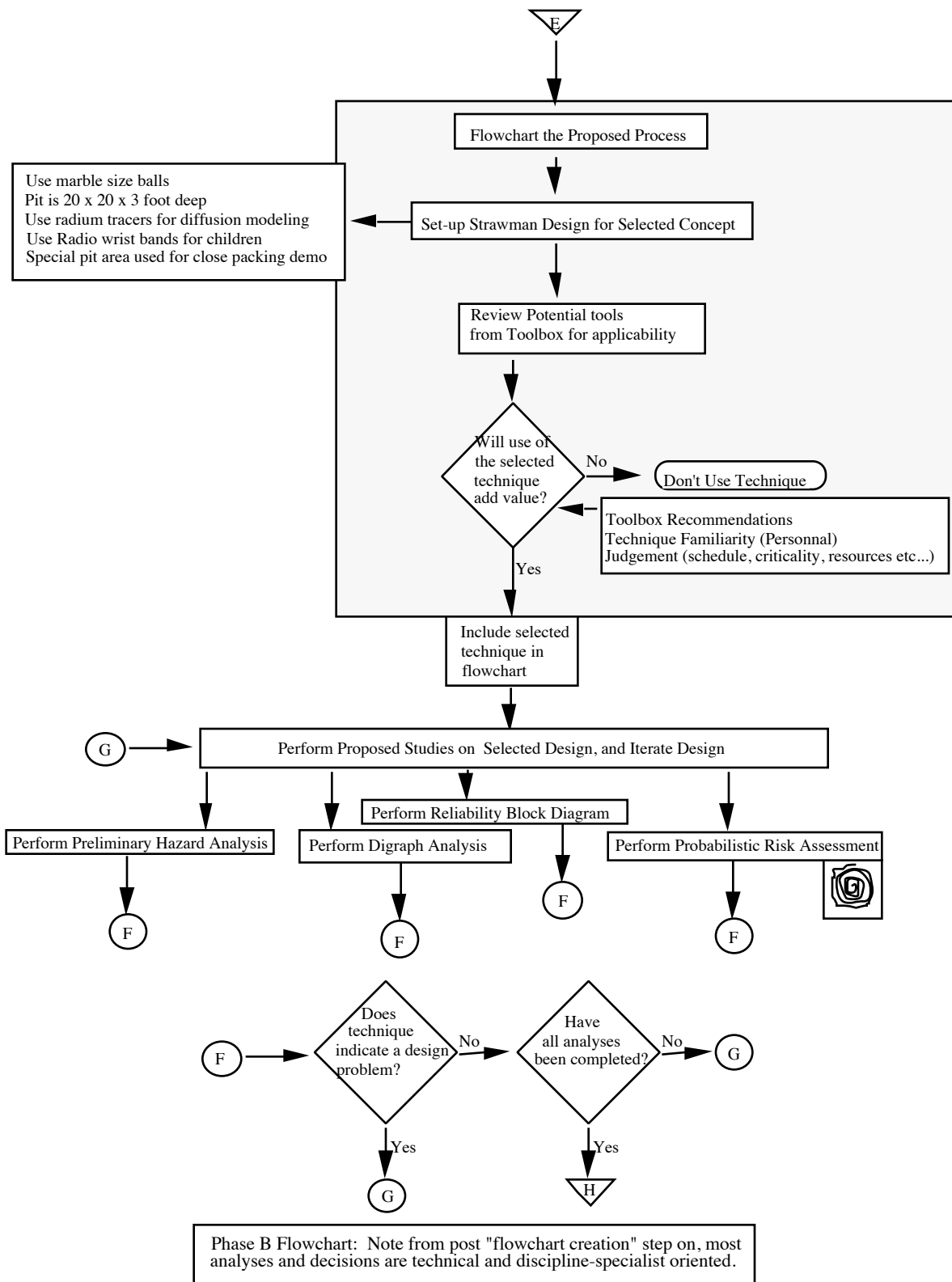

(b) Phase B.  
Figure B-1. Flowchart—Continued.

Jane wasn't laughing though. She noted that there was a change from the fundamental desirable attributes of a phase A program manager to those of a phase B manager. Decisions at the phase A level really required overall system experience and a capability for accepting available data, determining the appropriate level for additional data, and decision selection from the minimum, adequate (often very sparse) pool which that represented. Phase B efforts required a much more detail-driven selection process which employed the talents and capabilities of discipline specialists—management did well as a cheerleader here but might often leave the technical and some of the programmatic optimization decisions to the concurrent engineering team working the problem. Phases C and D were similar in nature to phase A.

Charlie began to feel a little better about things. He also noted that brainstorming was a technique that was seemingly suitable almost everywhere. He and Jane decided to use it to select a restaurant for dinner, after the rest of the group had gone home.

Charlie had gotten home very late Friday night, he was still sleeping when his boss's secretary, Fawn Hunter, called Saturday morning to let him know that first thing Monday morning Buck wanted to see what kind of progress they had made and discuss the project. He thanked Fawn for the information and got up to do some more work on the flowchart, and to try to start some of the other tools. It was looking like it was going to be a long weekend. About an hour later Jane called, volunteering to help. Charlie was the one smiling now—the prospects for the weekend were looking up. He liked the phase A and B flowcharts and added some of the symbols from the toolbox, just to key in on the difficulties for those particular areas. He also added the “should have done” boxes in addition to the “as performed” flows, and changed the phase B flowchart accordingly.

Charlie ran the calculations for the number of marbles in the ball pit:

Calculation of marble volume:

$$\text{Volume of a sphere} = (4/3) \pi r^3$$

$$r_{\text{marble}} = 0.5 \text{ in}$$

$$r^3_{\text{marble}} = 0.125 \text{ in}^3$$

$$V_{\text{marble}} = 0.52 \text{ in}^3.$$

Calculation of ball pit size:

Assume 20 ft×20 ft×3 ft

$$V_{\text{ballpit}} = 1,200 \text{ ft}^3 \times 1,728 \text{ in}/1 \text{ ft}^3 = 2.07 \times 10^6 \text{ in}^3.$$

The maximum packing density for spheres of a single diameter is 74 percent.

Calculation of number of marbles to “fill ball pit:”

$$\text{No. marbles} = (0.74) 2.07 \times 10^6 \text{ in}^3 / 0.52 \text{ in}^3 = 2.95 \times 10^6.$$

Although that was a huge amount of marbles (Charlie started wondering about the feasibility and cost of that many marbles), it didn't begin to approach Avogadro's number. Charlie was still at a loss for how to relate the two, and the diffusion part was still evading him. But now that they had this much of a start, he and Jane decided to perform the PHA. Once again it was time for brainstorming.

They filled up the first page with a list of 11 hazards (see figure B-2), first listing all of them, then identifying the targets for each of them, then working the severity and probability and risk factor. In this way they were able to concentrate on the ideas first, without getting caught up in the specific assessment issues or countermeasures. They used the toolbox risk assessment matrix (on page 3-10) that had been adapted from MIL-STD-882C. Jane suggested that they only work countermeasures for those items with a risk priority code of 1 or 2. There wasn't any need to improve on those with a 3. Charlie was quite surprised to find that the marbles represented such a significant risk. They settled on a design change for that item.

After filling in the countermeasures and the new risk Priority Codes, they were left only with two items of code level 2. Charlie didn't know how to work these and neither did Jane. Jane did mention though that they might just be a function of the integrated exhibit area (IEA)—disease transmission in children's museums was a common occurrence and wherever children jumped, someone was liable to get jumped on. They decided to go eat a late lunch, pizza, and watch one of these ball pits in action.

After returning from lunch, Charlie did calculations for larger balls. He had gotten the idea of filling the balls with sand or salt to better compare with Avogadro's number. This also might be useful for partially addressing the crystal educational goal. He and Jane worked the new calculations for the larger balls, and for a salt filler.

Calculation of large ball volume:

$$\begin{aligned} \text{volume of a sphere} &= (4/3) \pi r^3 \\ r_{\text{ball}} &= 3.5 \text{ in} \\ r_{\text{ball}}^3 &= 4.29 \times 10^1 \text{ in}^3 \\ V_{\text{ball}} &= 1.8 \times 10^2 \text{ in}^3. \end{aligned}$$

The maximum packing density for spheres of a single diameter is 74 percent.

Calculation of number of balls to "fill the ball pit:"

$$\text{No. balls} = (0.74) 2.07 \times 10^6 \text{ in}^3 / 1.8 \times 10^2 \text{ in}^3 = 8.52 \times 10^3.$$

Volume of a grain of salt:

$$\text{volume of a cube} = abc$$

assume (*a*) is approximately equal to (*b*), which is approximately equal to (*c*)

assume  $a = 0.01 \text{ in}$ .

## Preliminary Hazard Analysis

Brief Descriptive Title (Portion of System/Subsystem/Operational Phases covered by this analysis): Ball Pit for Science Hands-On Museum Display										
Probability Interval: 25 years	Date: February 1994	Hazard Target*	Risk Before			Description of Countermeasures	Risk After			
System Number: _____	Analysis: <input checked="" type="checkbox"/> Initial <input type="checkbox"/> Revision <input type="checkbox"/> Addition		Severity	Probability	Risk Code	Identify countermeasures by appropriate code letter(s): D = Design Alteration    E = Engineered Safety Feature S = Safety Device    W = Warning Device P = Procedures/Training	Severity	Probability	Risk Code	
Hazard No. / Description										
1. Cut hand on sharp edges.	P	III	B	2	D- Place bumpers on all potential sharp edges.	III	E	3		
2. Fall in pit.	P	III	A	2	P - Have posted rules and trained monitors.	II	C	3		
	E	IV	A	3	D - Use soft balls and padded surfaces.	IV	C	3		
	T	IV	A	3		IV	C	3		
3. Suffocate under balls.	P	I	D	2	D - Use larger balls. E - Limit use to children 3 feet tall or taller.	I	E	3		
4. Suffocate on marbles.	P	I	C	1	D - Use larger balls.	I	F	3		
5. Cancer risk from radium.	P	II	E	3						
6. Health risk from radio waves.	P	III	D	3						
7. Children landing on each other.	P	III	A	2	P - Have posted rules and trained monitors.	III	A	2		
8. Balls (marbles) breaking and leaving sharp objects in pit.	P	III	D	3						
	T	III	D	3						
9. Big children landing on small children or pit walls.	P	III	B	2	P - Limit age of children in the pit to 7 years old or less.	III	C	3		
	T	IV	B	3	D - Use padded surfaces.	IV	C	3		
10. Risk of disease communication.	P	III	A	2	P - No very effective countermeasure .	III	A	2		
11. Balls becoming projectiles in and out of pit.	P	III	A	2	P - Have posted rules and trained monitors.	III	C	3		
Prepared by/Date:	*Target Codes: P—Personnel E—Equipment T—Downtime R—Product V—Environment			Approved by/Date:						

$$V_{\text{salt grain}} = (0.01\text{in})^3 = 1.0 \times 10^{-6} \text{ in}^3.$$

Calculation of the number of grains of salt to “fill ball pit:”

$$\text{No. salt grains} = 2.07 \times 10^6 \text{ in}^3 / 1.0 \times 10^{-6} \text{ in}^3 = 2.07 \times 10^{12}.$$

The assumption was made that a ball has zero wall thickness and the salt grains will “magically stack” in a spherical container.

Calculation of the number of grains of salt per ball:

$$\begin{aligned} \text{No. grains/ball} &= (V_{\text{ball}}/V_{\text{salt}}) = (1.8 \times 10^2 \text{ in}^3 / 1.0 \times 10^{-6} \text{ in}^3) \\ &= 1.8 \times 10^8 \text{ grains/ball} \end{aligned}$$

Calculation of number of grain-filled balls required to house Avogadro’s number of grains:

$$\begin{aligned} \text{No. balls} &= Av = (1.8 \times 10^8 \text{ grains/ball}) (x) = 6.02 \times 10^{23} \\ &= 3.34 \times 10^{15}. \end{aligned}$$

The maximum packing density for spheres of a single diameter is 74 percent.

Calculation of required ball pit volume to contain  $3.34 \times 10^{15}$  balls:

$$\begin{aligned} V_{\text{ballpit}} &= (V_{\text{ball}}) (\text{No. balls}) = (1.8 \times 10^2 \text{ in}^3) (3.34 \times 10^{15}) / 0.74 \\ &= 8.12 \times 10^{17} \text{ in}^3 = 3,195 \text{ mi}^3 \end{aligned}$$

Calculation of cube side required to make a cube of volume = 2,364 miles<sup>3</sup>:

$$\text{Side} = (3,195 \text{ miles}^3)^{1/3} = 17.97 \text{ mi.}$$

There. They had made some major progress, and Charlie was beginning to visualize this exhibit. He knew they were ready to talk with Buck on Monday. He did want to find out about using the PHA tool for programmatic risk evaluation, and he had begun doodling with some small fault trees and was impressed by what he could do with them. He had already pretty much decided not to do the PRA assessment and....

### **Epilogue...Two (and a Half) for the Show**

Opening day of the museum was a media event. There were speeches and interviews and plenty of good words for all. Mr. and Mrs. Smith stayed in the background letting others soak up the limelight. They were pleased and proud of what they had done, and excited that their soon-to-be-born child would get to visit the museum often. Those lifetime passes for their family turned out to be a great wedding gift! Charlie was putting together a short report on the lessons learned during those first few months of the project—Jane was going to use it as a case study during her next class on the toolbox. He had left it at home for Jane to read, she smiled again as she recalled the listing:

- (1) The toolbox is just a guide. Use techniques that have value specific to the requirements, not simply because they are available or recommended.
- (2) Don't be afraid to use techniques that you're unfamiliar with—but get expert help when required! Anything can be misused.
- (3) Expect to make mistakes enroute to success. Learn to recognize and correct them.
- (4) Using the techniques does not mitigate the need for facts and data—rather it better defines the need (garbage in—garbage out).
- (5) Brainstorming is almost universally useful.
- (6) When she smiles, my wife is always right.

**APPENDIX C**  
**GLOSSARY OF TERMS**





## GLOSSARY OF TERMS

Term	Definition
Analysis	An examination of the elements of a system; separation of a whole into its component parts. (Reference Section 4.1)
AND Gate	A logic gate for which an output occurs if all inputs co-exist. All inputs are necessary and sufficient to cause the output to occur. (Reference Section 3.5)
Backwards Logic	The mental process in which an analyst models a system by repeatedly asking the question, " <i>What will cause a given failure to occur?</i> " Also called top-down logic. (Reference Section 3.0)
Barrier	A countermeasure against hazards caused by a flow from an energy source to a target. (Reference Section 3.3).
Basic Event	An initiating fault or failure in a fault tree that is not developed further. Also called an initiator or leaf. These events determine the resolution limit for a fault tree analysis.
Cause	The event or condition responsible for an action or result. (Reference Section 3.10)
Common Cause	A source of variation that is always present; part of the random variation inherent in the process itself.
Consequence	Something that follows from an action or condition; the relation of a result to its cause. (Reference Section 3.10)
Control Limits	Limits (also called action limits) set between the mean or nominal values of a parameter and specification limits. If a control limit is exceeded, corrective actions may need to be implemented before the specification limit is exceeded. (Reference Section 5.2)
Countermeasure	An action taken or a feature adopted to reduce the probability and/or severity of risk for a hazard. (Reference Sections 3.2 and 3.4))
Creative Function	The means of seeing new ways to perform work by breaking through barriers that often stifle thinking. Some techniques that are considered creative tools are evolutionary operation (Section 7.6), brainstorming (Section 7.7), and nominal group technique (Section 7.10). (Reference Table 1-1)

## GLOSSARY OF TERMS

Term	Definition
Critical Items List (CIL)	A FMEA-derived list (published as FMEA/CIL) containing system items that have a criticality of 1 or 2, and items that are criticality 1R or 2R and fail redundancy screens. (Reference Section 3.4)
Criticality	In reference to a parameter, criticality is the level of importance the parameter has to the operation of the system. (Reference Section 3.4)
Customer	The internal or external person or organization that is the user of a product being produced or service being rendered. The immediate customer is the user of the product or service in the next step of the process.
Cut Set	Any group of fault tree initiators which, if all occur, will cause the TOP event to occur. (Reference Section 3.6)
Data Analysis Function	The means of analyzing a process by using a data display. Some techniques that are considered data analysis tools are checklists (Section 7.8), control charts (Section 5.2), and force field analysis (Section 7.11). (Reference Table 1-1)
Decision Making Function	After analyzing all available data, a decision is made on how to optimize the subject process. Some techniques that are considered decision making tools are benchmarking (Section 7.1), nominal group technique (Section 7.10), and force field analysis (Section 7.11). (Reference Table 1-1)
Degrees of Freedom	The number of independent unknowns in the total estimate of a factorial effect or a residual. (Reference Section 6.2)
Facilitator	A person trained in group dynamics and problem-solving structures who assumes the responsibility for ensuring a full exchange of information between team members. (Reference Section 7.2)
Factor	A parameter or variable that affects product/process performance. (Reference Section 6.2)
Fail Safe	Proper function is impaired or lost but no further threat of harm occurs. (Reference Section 3.4)
Failure	A fault owing to breakage, wear out, compromised structural integrity, etc. (Reference Section 3.4)

## GLOSSARY OF TERMS

Term	Definition
Failure Domain	In analysis work, failure domain refers to an analysis that seeks the probability of a system not operating correctly. (Reference Section 3.8)
Failure Mode	The manner in which a failure occurs, i.e. the manner in which it malfunctions. (Reference Section 3.4)
Failure Propagation Path	The sequence of events that leads to an undesirable event or loss. Also called an accident sequence.
Fault	Inability to function in a desired manner, or operation in an undesired manner, regardless of cause. (Reference Section 3.6)
Forward Logic	The mental process in which an analyst models a system by repeatedly asking the question, " <i>What happens when a given failure occurs?</i> " Also called bottom-up logic. (Reference Section 3.0)
Graphical Function	The means of analyzing the data of a process by applying graphs and/or charts. Some of the techniques that are considered graphical tools are cause and effect diagram (Section 7.2), control charts (Section 5.2), and quality function deployment (Section 7.12). (Reference Table 1-1)
Hazard	An activity or condition which poses a threat of loss or harm; a condition requisite to a mishap. (Reference Section 3.2)
Intermediate Event	An event that describes a system condition produced by preceding event and contributing to later events.
Mean	The term used to describe a sample population average. (Reference Section 6.1)
Mean Square Deviation (MSD)	A measure of variability around the mean or target value.
Mishap	An undesired loss event. (Reference Section 8.3)
Modeling Function	The means of analyzing and modeling a process against standards and/or other processes. Some of the techniques that are considered modeling tools are benchmarking (Section 7.1), quality function deployment (Section 7.12), and work flow analysis (Section 7.16). (Reference Table 1-1)

## GLOSSARY OF TERMS

Term	Definition
OR Gate	A logic gate in which an output occurs if one or more inputs exist. Any single input is necessary and sufficient to cause the output to occur. (Reference Section 3.5)
Parameter	The term applied to population or sample characteristics such as the mean and standard deviation. (Reference Section 5.2)
Path Set	A group of fault tree initiators which, if none of them occurs, will guarantee that the TOP event cannot occur. (Reference Section 3.6)
Population	The universe of data under investigation from which a sample will be taken. (Reference Section 6.1)
Preliminary	Coming before and usually forming a necessary prelude to something. As in a preliminary hazard analysis, the analysis can be performed in the design or pre-operation phase, or it can be the first analysis performed for a mature system. (Reference Section 3.2)
Prevention Function	The means of analyzing data to be able to recognize potential problems and prevent the process from heading in an adverse direction. Some of the techniques that are considered preventive tools are control charts (Section 5.2), Pareto analysis (Section 5.6), and design of experiments (Section 7.5). (Reference Table 1-1)
Probability	The likelihood an event will occur within a defined time interval. (Reference Section 3.14)
Problem Identification Function	The means of identifying potential problems from a data display as a result of an analysis of the process. Some techniques that are considered problem identification tools are control charts (Section 5.2), brainstorming (Section 7.7), and quality function deployment (Section 7.12). (Reference Table 1-1)
Process	A series of events progressively moving forward over time to produce products or services for a customer. (Reference Section 7.1)
Project Phase A	The conceptual trade studies phase of a project. Quantitative and/or qualitative comparison of candidate concepts against key evaluation criteria are performed to determine the best alternative. (Reference Section 1.3)

## GLOSSARY OF TERMS

Term	Definition
Project Phase B	The concept definition phase of a project. The system mission and design requirements are established and design feasibility studies and design trade studies are performed during this phase. (Reference Section 1.3)
Project Phase C	The design and development phase of a project. System development is initiated and specifications are established during this phase. (Reference Section 1.3)
Project Phase D	The fabrication integration, test, and evaluation phase of a project. The system is manufactured and requirements verified during this phase. (Reference Section 1.3)
Project Phase E	The operations phase of a project. The system is deployed and system performance is validated during this phase. (Reference Section 1.3)
Qualitative	Data that are not numerical in nature. (Reference Section 2.1)
Quantitative	Data that are numerical in nature or can be described numerically. (Reference Section 2.1)
Range	A measure of the variation in a set of data. It is calculated by subtracting the lowest value in the data set from the highest value in that same set. (Reference Section 5.2)
Raw Data	Data as measured or as taken directly from instruments or sensors. (Reference Section 8.4)
Reliability	The probability of successful operation of a system over a defined time interval. (Reference Section 3.3)
Risk	For a given hazard, risk is the long-term rate of loss; the product of loss severity and loss probability. (Reference Section 3.1)
Sample	One or more individual events or measurements selected from the output of a process for purposes of identifying characteristics and performance of the whole. (Reference Section 6.1)
Severity	The degree of the consequence of a potential loss for a hazard. (Reference Section 3.1)
Special Cause	A source of variation that is intermittent, unpredictable, unstable; sometimes called an assignment cause. It is signalled by a point beyond the control limits. (Reference Section 8.1)

## GLOSSARY OF TERMS

Term	Definition
Standard Deviation	A measure of variability used in common statistical tests. The square root of the variance. (Reference Section 6.1)
Subassembly	A composite of components. (Reference Section 3.4)
Success Domain	In analysis work, success domain refers to an analysis that seeks the probability of a system operating correctly. (Reference Section 3.8)
System	A composite of subsystems whose functions are integrated to achieve a mission (includes materials, tools, personnel, facilities, software, and equipment).
System Element	A constituent of a system that may be a subsystem assembly, component, or piece-part.
Target	An object having worth that is threatened by a hazard. The object may be personnel, equipment, downtime, product, data, environment, etc. (Reference Section 3.1)
Threat	A potential for loss. A hazard. (Reference Section 3.1)
TOP Event	The conceivable, undesired event to which failure paths of lower level events lead. (Reference Section 3.6)
Trends	The patterns in a run chart or control chart that feature the continued rise or fall of a series of points. Like runs, attention should be paid to such patterns when they exceed a predetermined number (statistically based). (Reference Section 8.0)
Upper Control Limit Range	The upper control limit for the moving range chart for a set of data. (Reference Section 7.14)
Variation	The inevitable difference among individual outputs of a process. The sources of variation can be grouped into two major classes: Common Causes and Special Causes. (Reference Section 6.2)
Weighting Factor	A method of rating the relative importance of a concern or selection criterion as related to comparable concerns or selected criteria. (Reference Sections 2.1 and 7.12)

**APPENDIX D**  
**HAZARDS CHECKLIST**





## HAZARDS CHECKLIST

### Electrical

- Shock
- Burns
- Overheating
- Ignition of Combustibles
- Inadvertent Activation
- Power Outage
- Distribution Backfeed
- Unsafe Failure to Operate
- Explosion/Electrical (Electrostatic)
- Explosion/Electrical (Arc)

### Mechanical

- Sharp Edges/Points
- Rotating Equipment
- Reciprocating Equipment
- Pinch Points
- Lifting Weights
- Stability/Topping Potential
- Ejected Parts/Fragments
- Crushing Surfaces

### Pneumatic/Hydraulic Pressure

- Overpressurization
- Pipe/Vessel/Duct Rupture
- Implosion
- Mislocated Relief Device
- Dynamic Pressure Loading
- Relief Pressure Improperly Set
- Backflow
- Crossflow
- Hydraulic Ram
- Inadvertent Release
- Miscalibrated Relief Device
- Blown Objects
- Pipe/Hose Whip
- Blast

### Acceleration/Deceleration/Gravity

- Inadvertent Motion
- Loose Object Translation
- Impacts
- Falling Objects
- Fragments/Missiles
- Sloshing Liquids
- Slip/Trip
- Falls

### Temperature Extremes

- Heat Source/Sink
- Hot/Cold Surface Burns
- Pressure Evaluation
- Confined Gas/Liquid
- Elevated Flammability
- Elevated Volatility
- Elevated Reactivity
- Freezing
- Humidity/Moisture
- Reduced Reliability
- Altered Structural Properties (e.g., Embrittlement)

### Radiation (Ionizing)

- Alpha
- Beta
- Neutron
- Gamma
- X-Ray

### Radiation (Non-Ionizing)

- Laser
- Infrared
- Microwave
- Ultraviolet

#### Notes:

1. Neither this nor any other hazards checklist should be considered complete. This list should be enlarged as experience dictates. This list contains intentional redundant entries.
2. This checklist was extracted from "Preliminary Hazard Analysis (Lecture Presentation)", R.R. Mohr, Sverdrup Technology, Inc., June 1993 (Fourth Edition).

## HAZARDS CHECKLIST

### Fire/Flammability - Presence of:

- Fuel
- Ignition Source
- Oxidizer
- Propellant

### Explosives (Initiators)

- Heat
- Friction
- Impact/Shock
- Vibration
- Electrostatic Discharge
- Chemical Contamination
- Lightning
- Welding (Stray Current/Sparks)

### Explosives (Effects)

- Mass Fire
- Blast Overpressure
- Thrown Fragments
- Seismic Ground Wave
- Meteorological Reinforcement

### Explosives (Sensitizes)

- Heat/Cold
- Vibration
- Impact/Shock
- Low Humidity
- Chemical Contamination

### Explosives (Conditions)

- Explosive Propellant Present
- Explosive Gas Present
- Explosive Liquid Present
- Explosive Vapor Present
- Explosive Dust Present

### Leaks/Spills (Material Conditions)

- Liquid/Cryogenics
- Gases/Vapors
- Dusts - Irritating
- Radiation Sources
- Flammable
- Toxic
- Reactive
- Corrosive
- Slippery
- Odorous
- Pathogenic
- Asphyxiating
- Flooding
- Run Off
- Vapor Propagation

### Chemical/Water Contamination

- System-Cross Connection
- Leaks/Spills
- Vessel/Pipe/Conduit Rupture
- Backflow/Siphon Effect

### Physiological (See Ergonomic)

- Temperature Extremes
- Nuisance Dusts/Odors
- Baropressure Extremes
- Fatigue
- Lifted Weights
- Noise
- Vibration (Raynaud's Syndrome)
- Mutagens
- Asphyxiants
- Allergens
- Pathogens
- Radiation (See Radiation)
- Cryogenics
- Carcinogens
- Teratogens
- Toxins
- Irritants

#### Notes:

1. Neither this nor any other hazards checklist should be considered complete. This list should be enlarged as experience dictates. This list contains intentional redundant entries.
2. This checklist was extracted from "Preliminary Hazard Analysis (Lecture Presentation)", R.R. Mohr, Sverdrup Technology, Inc., June 1993 (Fourth Edition).

## HAZARDS CHECKLIST

### Human Factors (See Ergonomic)

- Operator Error
- Inadvertent Operation
- Failure to Operate
- Operation Early/Late
- Operation Out of Sequence
- Right Operation/Wrong Control
- Operated Too Long
- Operate Too Briefly

### Unannounced Utility Outages

- Electricity
- Steam
- Heating/Cooling
- Ventilation
- Air Conditioning
- Compressed Air/Gas
- Lubrication Drains/Slumps
- Fuel
- Exhaust

### Ergonomic (See Human Factors)

- Fatigue
- Inaccessibility
- Nonexistent/Inadequate "Kill" Switches
- Glare
- Inadequate Control/Readout Differentiation
- Inappropriate Control/Readout Location
- Faulty/Inadequate Control/Readout Labeling
- Faulty Work Station Design
- Inadequate/Improper Illumination

### Common Causes

- Utility Outages
- Moisture/Humidity
- Temperature Extremes
- Seismic Disturbance/Impact
- Vibration
- Flooding
- Dust/Dirt
- Faulty Calibration
- Fire
- Single-Operator Coupling
- Location
- Radiation
- Wear-Out
- Maintenance Error
- Vermin/Varmints/Mud Daubers

### Control Systems

- Power Outage
- Interferences (EMI/ESI)
- Moisture
- Sneak Circuit
- Sneak Software
- Lightning Strike
- Grounding Failure
- Inadvertent Activation

### Contingencies (Emergency Responses by System/Operators to "Unusual" Events):

- "Hard" Shutdowns/Failures
- Freezing
- Fire
- Windstorm
- Hailstorm
- Utility Outrages
- Flooding
- Earthquake
- Snow/Ice Load

#### Notes:

1. Neither this nor any other hazards checklist should be considered complete. This list should be enlarged as experience dictates. This list contains intentional redundant entries.
2. This checklist was extracted from "Preliminary Hazard Analysis (Lecture Presentation)", R.R. Mohr, Sverdrup Technology, Inc., June 1993 (Fourth Edition).

## HAZARDS CHECKLIST

### Mission Phasing

- \_\_\_\_\_ Transport
- \_\_\_\_\_ Delivery
- \_\_\_\_\_ Installation
- \_\_\_\_\_ Calibration
- \_\_\_\_\_ Checkout
- \_\_\_\_\_ Shake Down
- \_\_\_\_\_ Activation
- \_\_\_\_\_ Standard Start
- \_\_\_\_\_ Emergency Start
- \_\_\_\_\_ Normal Operation
- \_\_\_\_\_ Load Change
- \_\_\_\_\_ Coupling/Uncoupling
- \_\_\_\_\_ Stressed Operation
- \_\_\_\_\_ Standard Shutdown
- \_\_\_\_\_ Shutdown Emergency
- \_\_\_\_\_ Diagnosis/Trouble Shooting
- \_\_\_\_\_ Maintenance

#### Notes:

1. Neither this nor any other hazards checklist should be considered complete. This list should be enlarged as experience dictates. This list contains intentional redundant entries.
2. This checklist was extracted from "Preliminary Hazard Analysis (Lecture Presentation)", R.R. Mohr, Sverdrup Technology, Inc., June 1993 (Fourth Edition).

**APPENDIX E**  
**EXAMPLE PRELIMINARY HAZARD ANALYSIS WORKSHEET**



## Example Preliminary Hazard Analysis Worksheet\*

### Preliminary Hazard Analysis

Brief Descriptive Title (Portion of System/Sub-system/Operational Phases covered by this analysis):						
Probability Interval: 25 years	Date:	Risk Before			Risk After	
System Number: _____	Analysis: <input type="checkbox"/> Initial <input type="checkbox"/> Revision <input type="checkbox"/> Addition	Hazard Target*	Severity	Probability	Risk Code	Description of Countermeasures
Hazard No. / Description						Identify countermeasures by appropriate code letter(s): D = Design Alteration      E = Engineered Safety Feature S = Safety Device            W = Warning Device P = Procedures/Training
Severity	Probability	Risk Code	Severity	Probability	Risk Code	

Prepared by/Date:

\*Target Codes: P—Personnel E—Equipment  
T—Downtime R—Product V—Environment

Approved by/Date:

\*This worksheet was extracted from "Preliminary Hazard Analysis (Lecture Presentation)," R.R. Mohr, Sverdrup Technology, Inc., June 1993.

**APPENDIX F**  
**EXAMPLE FAILURE MODES AND EFFECTS ANALYSIS WORKSHEET**





## Example Failure Modes And Effects Analysis Worksheet\*

Failure Modes & Effects Analysis					Sheet _____ of _____				
Project No.: _____					Date: _____				
Subsystem: _____					Prep. by: _____				
System: _____					Rev. by: _____				
Probability Interval: _____					Approved by: _____				
Operational Phase(s): _____		FMEA No.: _____							
IDENT. No.	ITEM FUNCTIONAL IDENT.	FAILURE MODE	FAILURE CAUSE	FAILURE EFFECT	T A R G E T	RISK ASSESSMENT			ACTION REQUIRED / REMARKS
						SEV	PROB	Risk Code	

P: Personnel / E: Equipment / T: Downtime / R: Product / V: Environment

\*This worksheet was extracted from "Failure Modes and Effects Analysis (Lecture Presentation)," R.R. Mohr, Sverdrup Technology, Inc., July 1993.