

MSFC-SPEC-522B
July 1, 1987
Supersedes:
MSFC-SPEC-522A



National Aeronautics and
Space Administration

George C. Marshall Space flight Center
Marshall Space Flight Center, Alabama 35812

DESIGN CRITERIA FOR CONTROLLING STRESS CORROSION CRACKING

Prepared by
Materials & Processes Laboratory
George C. Marshall Space Flight Center

PLEASE
SEE:

DOCUMENT CHANGE RECORD

SHEET: i

CHANGE DOCUMENT:		MSFC-SPEC 522B		COPY NO.
		NUMBERED	REVISION	DATE
CHANGE (DATE)	TO INCORPORATE THE CHANGE INTO THE DOCUMENT:		OTHER COMMENTS REGARDING THIS CHANGE (AUTH., INSTRUCT., ETC.)	
	1. ADD PAGES;	2. REMOVE PAGES;		
HANGE 1 3-1-88	i			
	13	13		
	14	14		
	15	15		
	17	17		

3/15/88
RELEASE CH

MSFC-SPEC-522B
Supersedes:
MSFC-SPEC-522A



1913 Franklin EH 24 7/17/87
Prepared by Organization Date

Approved by Organization Date

R. S. Schweighart BH-01 8.4.87
Approved by Organization Date

STRESS

MATERIALS

1913 Franklin C. F. Ky 8-5-87

MSFC-SPEC-5225
Supersedes:
MSFC-SPEC-522A

GEORGE C. MARSHALL SPACE FLIGHT CENTER
NATIONAL AERONAUTICS AND SPACE ADMINISTRATION
MARSHALL SPACE FLIGHT CENTER, ALABAMA

DESIGN CRITERIA FOR CONTROLLING STRESS CORROSION CRACKING

1. PURPOSE:

This document sets forth the criteria to be used in the selection of materials for space vehicles and associated equipment and facilities so that failure resulting from stress corrosion will be prevented.

2. SCOPE:

The requirements established herein apply to all metallic components proposed for use in space vehicles and other flight hardware, ground support equipment, and facilities for testing. These requirements are applicable not only to items designed and fabricated by MSFC and its prime contractors, but also to items supplied to the prime contractor by subcontractors and vendors.

3. GENERAL:

3.1 Definition

Stress corrosion may be defined as the combined action of sustained tensile stress and corrosion to cause premature failure of, materials. Certain materials are more susceptible than others. If a susceptible material is placed in service in a corrosive environment under tension of sufficient magnitude, and the duration of service is sufficient to permit the initiation and growth of cracks, failure will occur at a stress lower than the material would normally be expected to withstand. The corrosive environment need not be severe in terms of general corrosive attack. Service failures due to stress corrosion are frequently encountered for which the surfaces of the failed parts are not visibly corroded in a general sense. If failure is to be avoided, the total tensile stress in service must be maintained at a safe level. There is no absolute threshold stress for stress corrosion, such as with other material

properties, but comparative stress corrosion thresholds can be determined for materials for certain controlled **conditions** of test. Estimates of the stress corrosion threshold for a **specific** service application must be determined for, each alloy and heat treatment using a test piece, stressing procedure, and corrosive environment that are appropriate for the intended service.

3.2 Limitations

The stress corrosion susceptibility of alloys included in this document was determined at ambient temperature by laboratory tests in which specimens were **either** sprayed with salt water or periodically immersed and withdrawn, by exposure of specimens in seacoast or mild industrial **environ-**ments, and by service experience with fabricated hardware. Use of **the criteria** established herein should, therefore, be limited to designs for service **involving** similar exposure conditions. Behavior of the listed materials at elevated temperature, and in **specific** chemical environments other than those mentioned above, must be ascertained by additional testing.

Weldments present a special problem in designing for resistance to stress corrosion cracking. In addition to the susceptibility of the parent metals, it is also necessary to consider the filler metal and the microstructural effects of heat introduced by the welding operations and subsequent heat treatments. Because of the additional variables which must be considered, susceptibility data are not as extensive for weldments as for alloys in mill form. Design criteria for weldments in **this** document are limited to aluminum alloys, selected stainless steels in the 300 series, and other specific alloys listed in Table I.

This document is intended to provide general criteria to be used in designing for resistance to stress corrosion cracking. Specific test data and other detailed information are not included. However, a **list** of references is attached as Appendix A from which additional information can be obtained.

3.3 Grain Orientation

Rolling, extruding, and forging are the most common processing operations employed in the production of standard wrought forms of metal. All produce a flow of metal in a predominant **direction** so that, microscopically, the metal is neither isotropic nor homogeneous. As a result, the properties of the metal vary according to the direction **in** which they are measured. The extent of directional **variation** depends on the property of interest. For susceptibility to stress corrosion cracking, the directional variation can be appreciable and must be considered in the design of fabricated hardware.

The **anisotropy** of grain orientation produced by rolling and extruding is illustrated **schematically** in Figure 1. Taking the rolled plate as an example, it is conventional to describe the direction of rolling as the longitudinal direction, the **direction** perpendicular to the longitudinal and in the plane of the plate as the long transverse direction, and the direction through the thickness of the plate as the short transverse **direction**. For certain shapes, it is not possible to distinguish both a long and short transverse direction based *on the* simple rules used to identify those directions for plate. As an example, consider the **thick** tee illustrated in Figure 2 where a **region** with both long and short transverse orientations has been identified based on experience with that particular shape and a knowledge of the forming method.

Forgings also require **special** consideration in identifying the short transverse direction. In a forging **operation**, the flow of metal is influenced and constrained by the shape of the die cavity. For complex shapes, there may be several regions where a short transverse direction exists. The direction perpendicular to the parting' plane of the dies is always short transverse as illustrated in Figure 3.

The resistance of metals, particularly alloys of aluminum, to stress corrosion cracking is always less when tension is applied in a transverse direction. It is **least** for the short transverse direction. Figures 2 and 3 were drawn to illustrate undesirable situations in which tensile stresses due to assembly have been applied in the short transverse **direction**. For **optimum** resistance to stress corrosion **cracking**, similar situations **must be** avoided in structural design.

3.4 Stress Considerations

In designing for stress corrosion resistance it is important to realize that stresses are additive and threshold stresses for **susceptibility** are often low. There have been a number of stress corrosion failures for which design stresses were intermittent and of short duration, and only of minor significance in contributing to failure. Stress corrosion cracking in those cases occurred because of a combination of residual and assembly stresses not even anticipated in design. All possible **sources** of stress must be considered to ensure that threshold stresses are not exceeded. In addition to stresses resulting from operational, transportation, and storage loads which **are anticipated** during design; assembly and residual stresses also contribute to stress corrosion, and in many cases are the major **contributors to** stress corrosion failure. Assembly stresses result from improper tolerances during **fit-up** (Figures 2 and 3), **overtorquing**, press fits, high interference fasteners, and welding.

Residual stresses are present in components of fabricated structure as a result of machining, forming, and heat treating operations. Some typical residual stress distributions through plate and rod are illustrated in Figure 4 to provide an indication of the magnitudes of stress which can be developed as the result of conventional heat treating and forming operations.

3.5 Susceptibility of Engineering Alloys

a. Aluminum - Many aluminum alloys exhibit excellent resistance to **stress** corrosion cracking in all standard tempers. However, the high strength alloys, which are of primary interest in aerospace applications, must be approached **cautiously**. Some are resistant only in the longitudinal **grain direction**, and the resistance of others varies with the specific temper. Because metallurgical processing of aluminum alloys usually **results in** a pronounced elongation of grains, the variation of susceptibility with grain orientation is more extensive than for other metals. Also, because of conventional processing methods designed to optimize strength, residual stresses, especially **in** thick sections, are usually greater in aluminum products than in wrought forms of other metals. It is for this reason that wrought, heat treatable aluminum products specified for use in the fabrication of hardware should be mechanically stress relieved (the **TX5X** or **TX5XX** temper designations) whenever possible.

Both the residual stress distribution and the grain orientation must be carefully considered in designing a part **to** be machined from wrought aluminum. Machining **will** not only alter the stress distribution, but as indicated in Figure 2a, it may also result in the exposure of a short transverse region on the surface of **the** finished part which **will** see tension in service.

b. Steel - Carbon and low alloy steels with ultimate tensile strengths below 180 **ksi are** generally resistant to stress corrosion cracking. **Austenitic** stainless steels of the 300 series are generally resistant, **Martensitic** stainless steels of the 400 series are more or less susceptible **depending on** composition and heat treatment. Precipitation hardening stainless steels vary in susceptibility from extremely high to extremely low depending on composition and heat treatment. The susceptibility of these steels is particularly sensitive to heat treatment, and special vigilance is required to avoid stress corrosion cracking problems.

c. Nickel - As a class, alloys with **high nickel content** are resistant **to** stress corrosion cracking.

MSFC-SPEC-5220

d. Copper - Natural atmospheres containing pollutants of sulfur dioxide, oxides of nitrogen, and ammonia are reported to cause stress corrosion cracking of some copper alloys. Chlorides present in marine atmospheres may cause stress corrosion problems but to a lesser extent than the previously listed pollutants, which indicates that industrial areas are probably more aggressive than marine sites to copper base alloys. Many copper alloys containing over 2.0 percent zinc are susceptible to stress corrosion cracking even in the presence of alloying additions which normally impart resistance to stress corrosion.

4. MATERIALS USAGE AGREEMENTS:

This document does not purport to be all inclusive of factors and criteria necessary for the total control of stress corrosion cracking in alloys. It is recognized that for many applications involving **unfamiliar** materials, or unusual combinations of materials and environments, existing data on stress corrosion susceptibility will be insufficient. To ensure adequate stress corrosion resistance in these situations, it will be necessary to conduct a detailed evaluation of susceptibility. The results must be submitted to MSFC for review, and MSFC approval will be required before the material can be used or incorporated in a design under the circumstances in question. The medium for submittal will be the Materials Usage Agreement (**MUA**), a copy of which is attached as Appendix B. In addition, all materials applications other than those explicitly approved according to the criteria set forth in this document will be predicated on MSFC approval of an **MUA** submitted either by a prime contractor or by a subcontractor through the prime. The **MUA** will contain the information specified on the Stress Corrosion Evaluation Form, attached as Appendix C, along with any other information deemed necessary for the accurate assessment of the potential for stress corrosion failure. Where possible, similar usages of the same or similar alloys should be submitted on a single **MUA**.

5. MATERIALS SELECTION CRITERIA:

Alloys and tempers which by testing and experience have been shown to possess high resistance to stress corrosion cracking are listed in Table I. **These should** be used preferentially, and MSFC approval is not required prior to their use. All other alloys and weldments not listed in Table I, except as specifically exempted, require that an **MUA** be submitted for approval.

MSFC-SPEC-522B

Alloys and tempers listed in Table II are moderately resistant to stress corrosion cracking. They should be considered for use only for cases where a suitable alloy cannot be found in Table I. An **MUA** must be submitted and **MSFC** approval must be given before any alloy or weldments in Table II can be used. Proposed utilization of materials from Table II in applications involving high installation stress, such as springs or fasteners, will not be approved. Sheet material (less than 0.250 inch thick) of the aluminum alloys and conditions listed in Table II is considered resistant to stress corrosion and does not require MSFC approval.

The alloys listed in Table III have been found to be highly susceptible to stress corrosion cracking. They should be considered for use only in applications where it can be demonstrated conclusively that the probability of stress corrosion is remote because of low sustained tensile stress (whatever its origin) in critical grain directions, suitable protective measures, or an innocuous environment. The use of materials in Table III must be substantiated by an **MUA** approved by MSFC.

Alloys used for electrical wiring, thermocouple wires, magnet wires and similar non-structural electrical or electronic applications are exempt from the requirements of this specification.

Protective coatings such as electroplate, anodize or chemical conversion coatings do not change the stress corrosion rating of alloys to which they are applied. Table II and III alloys thus treated must be identified and **MUA** and stress corrosion forms submitted to MSFC for approval **prior** to their use.

Surface treatments such as carburizing or nitriding may adversely affect the stress corrosion rating of materials to which they are applied. All materials thus treated must be identified and **MUA** and stress corrosion forms submitted to MSFC for approval prior to their use.

MSFC-SPEC-5228

The stress corrosion resistance of alloys and weldments not listed in this document must be ascertained either by tests conducted in an environment representative of the proposed application or by a direct comparison with similar alloys and weldments for which susceptibility is known to be low. An **MUA** must be submitted and approval obtained for each proposed application of an alloy or weldment not listed in this document. In special cases where specific data are already available on a material under environmental conditions representative of anticipated exposure conditions, an **MUA** for usage of this material within prescribed limits may be submitted for approval,

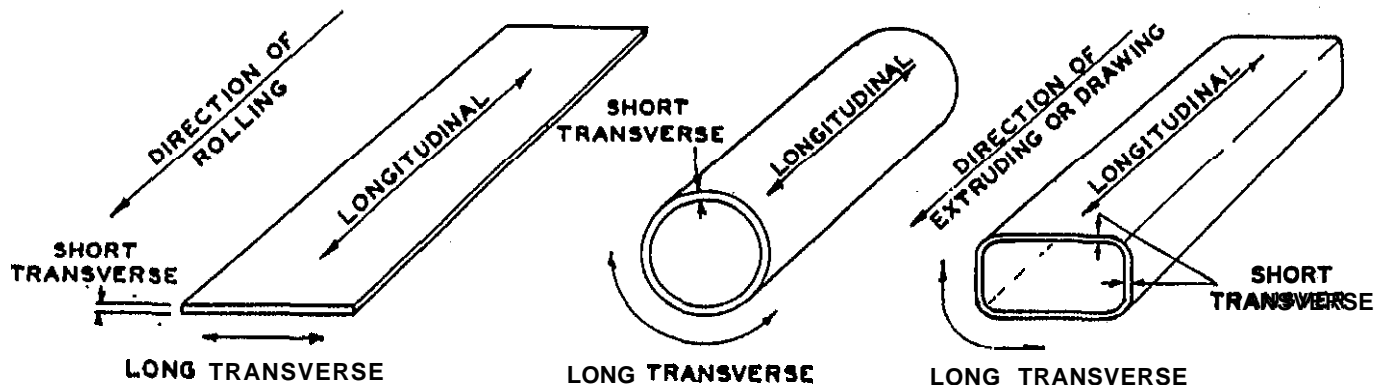

SHEET & PLATE

EXTRUDED & DRAWN TUBE

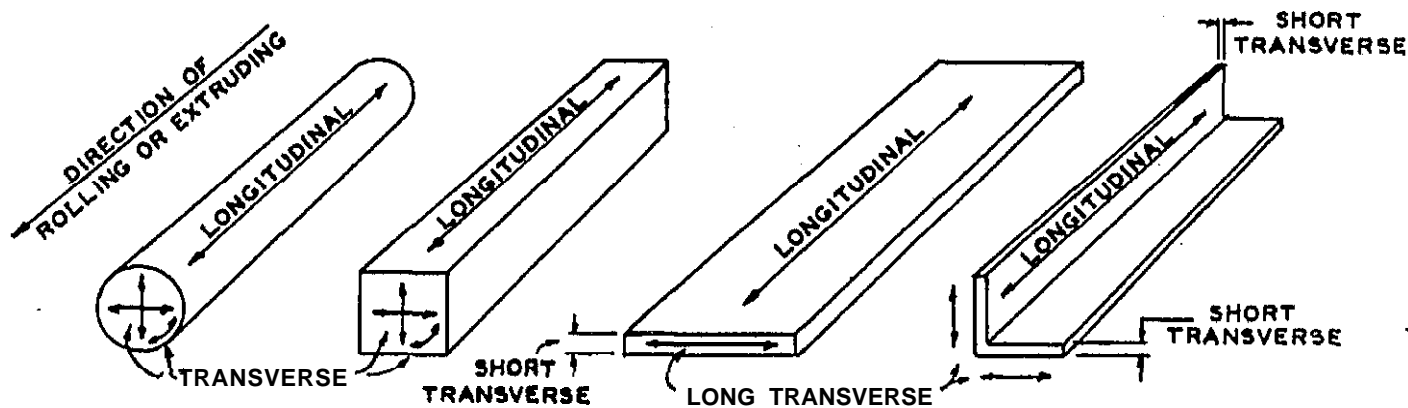

ROLLED & EXTRUDED ROD BAR & THIN SHAPES

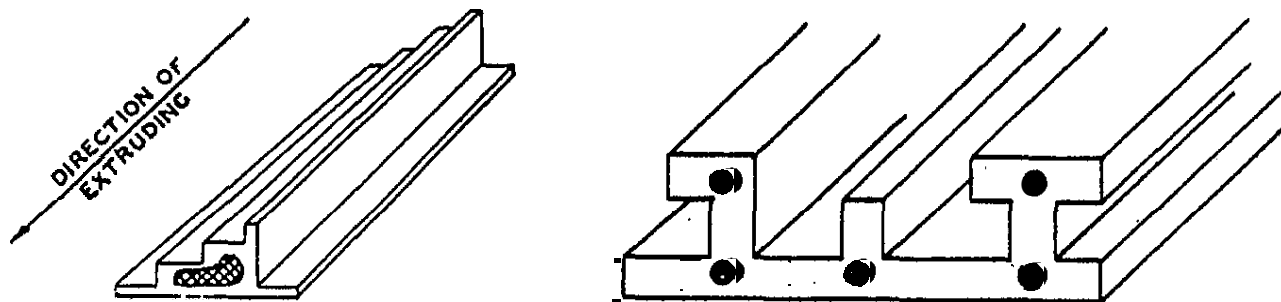

CROSS HATCHED AREAS ARE TRANSVERSE. OTHER AREAS SAME AS INDICATED above

EXTRUDED THICK & COMPLEX SHAPES

FIGURE 1 • GRAIN ORIENTATIONS IN STANDARD WROUGHT FORMS

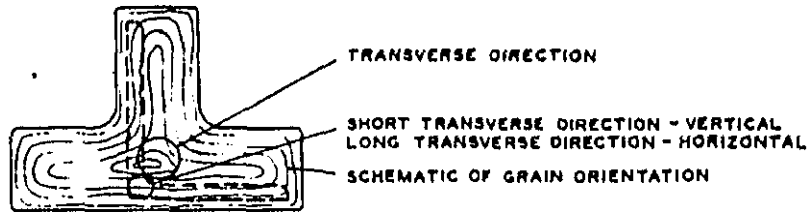

LOCATION OF MACHINED ANGLE WITH RESPECT TO TRANSVERSE GRAIN FLOW IN THICK TEE

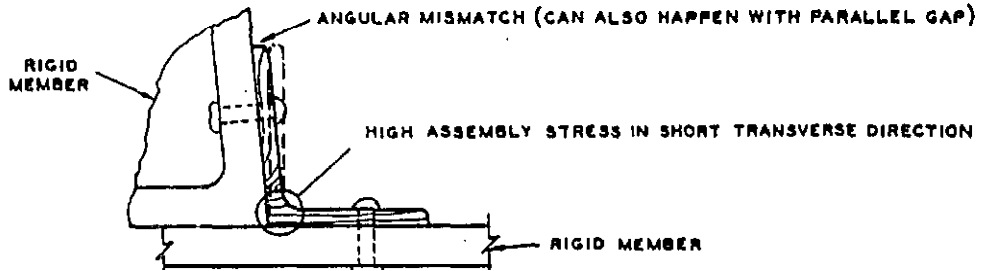

ASSEMBLY STRESS RESULTING FROM MISMATCH



LOCATION OF MACHINED CHANNEL IN PLATE OR BAR

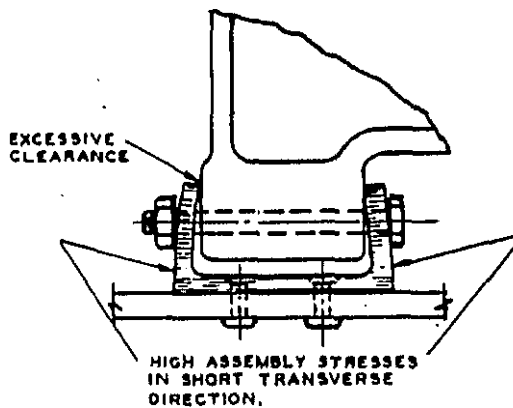

ASSEMBLY STRESS RESULTING FROM EXCESSIVE CLEARANCE

FIGURE 2 - EXAMPLES OF TENSILE STRESSES IN SHORT TRANSVERSE DIRECTION APPLIED DURING ASSEMBLY

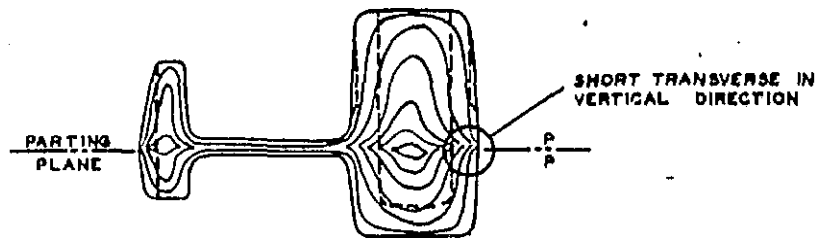

CROSS SECTION OF DIE FORGING SHOWING OUTLINE OF MACHINED PART

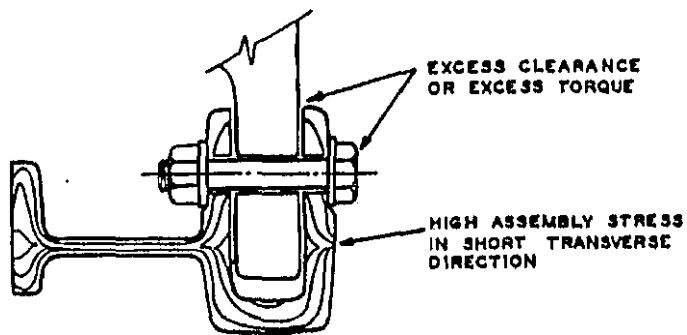

ASSEMBLY STRESS IN MACHINED FORGING WITH EXCESSIVE CLEARANCE

SHORT TRANSVERSE
DIRECTION PERPENDICULAR
TO PARTING PLANE

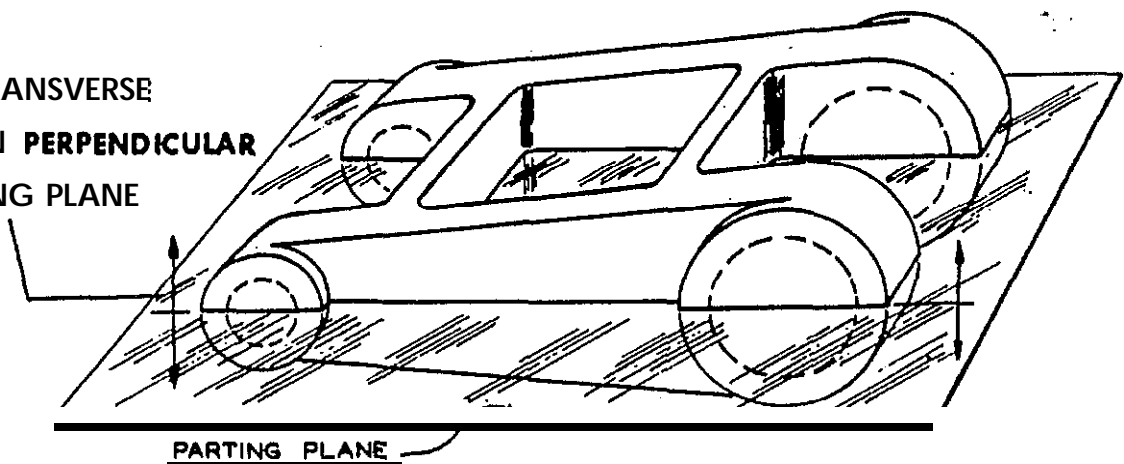

TYPICAL DIE FORGING, INTERFERENCE FIT BUSHINGS OR PINS IN HOLES SHOWN BY **DASHED** LINES IMPOSE **SUSTAINED** RESIDUAL TENSILE STRESSES IN TRANSVERSE DIRECTION

FIGURE 3 • EXAMPLES OF TENSILE STRESSES IN SHORT TRANSVERSE DIRECTION RESULTING FROM ASSEMBLY

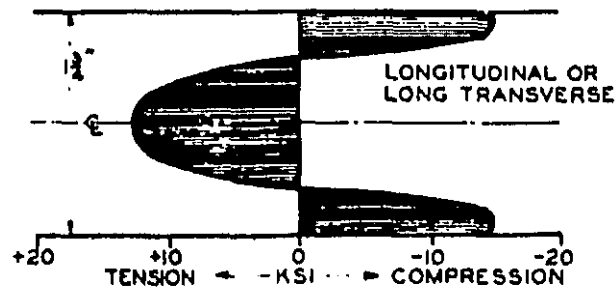

7075-T6 PLATE, QUENCHED IN COLD WATER AND NOT STRESS RELIEVED

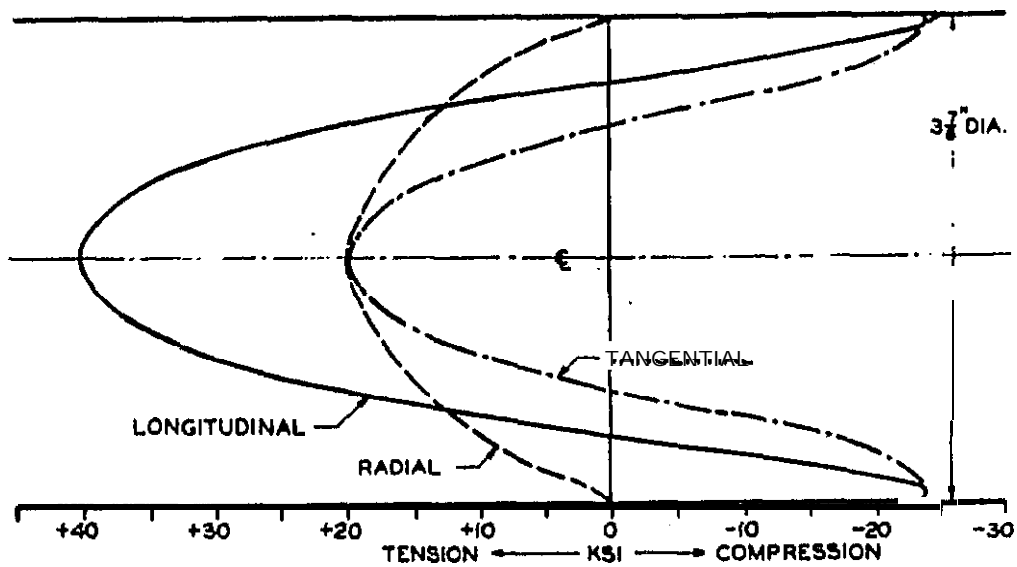

7075-T6 ROD, QUENCHED IN COLD WATER AND NOT STRESS RELIEVED.

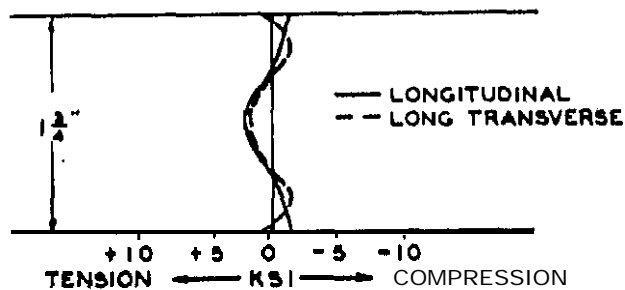

7075-T651 PLATE, STRETCHED 2% AFTER COLD WATER QUENCH.

FIGURE 4 - TYPICAL RESIDUAL STRESS DISTRIBUTIONS IN
7075 ALUMINUM ALLOY SHAPES

TABLE I

ALLOYS WITH HIGH RESISTANCE TO STRESS CORROSION CRACKING

STEEL ALLOYS

Alloy	Condition
Carbon Steel (1000 Series)	Below 180 ksi UTS
Low Alloy Steel (4130, 4340, D6AC, etc.)	Below 180 ksi UTS
Music Wire (ASTM 228)	Cold Drawn
1095 Spring Steel	Tempered
HY 80 Steel	Tempered
HY 130 Steel	Tempered
HY 140 Steel	Tempered
ASP 11	Aged
200 Series Stainless Steel (Unsensitized)	All
300 Series Stainless Steel (Unsensitized)(1)	All
400 Series Ferritic Stainless Steel (404, 430, 444, etc.)	All
Nitronic 32	Annealed
Nitronic 33(2)	Annealed
Nitronic 40 (formerly 21-6-9)(2)	Annealed
A-286 Stainless Steel	All
AM-350 Stainless Steel	SCT 1000 and Above
AM-355 Stainless Steel	SCT 1000 and Above
AM-362 (Almar 362) Stainless Steel	3 Hrs. at 1000°F
Carpenter 20Cb Stainless Steel	All
Carpenter 20Cb-3 Stainless Steel	All
Custom 450 Stainless Steel	H1000 and Above
Custom 455 Stainless Steel	H1000 and Above
15-5PH Stainless Steel	H1000 and Above
PH15-7Mo Stainless Steel	CH900
17-7PH Stainless Steel	CH900

(1) Including weldments of 304L, 316L, 321, and 347

(2) Including weldments

TABLE I
ALLOYS WITH HIGH RESISTANCE TO STRESS CORROSION CRACKING

(Continued)

ALUMINUM ALLOYS

<u>Wrought</u>		<u>Cast</u>	
<u>Alloy</u> ⁽¹⁾	<u>Temper</u> (')	<u>Alloy</u> ⁽³⁾	<u>Temper</u>
1000 Series	All	319.0, A319.0	As Cast
2011	T8	333.0, A333.0	As Cast
2024 Rod, Bar	T8	355.0, C355.0	T6
2219	T6, T8	356.0, A356.0	All
2618	T6	357.0	All
3000 Series	All	8358.0 (Tens-50)	All
5000 Series	All ^{(4), (5)}	359.0	All
6000 Series	All	380.0, A380.0	As Cast
7049	T73	514.0, (214)	As Cast ⁽⁵⁾
7149	T73	518.0, (218)	As Cast ⁽⁵⁾
7050	T73	535.0 (Almag 35)	As Cast ⁽⁵⁾
7075	T73	A712.0, C712.0	As Cast
7475	T73		

(1) Including weldments of the weldable alloys.

(2) Including mechanically stress relieved (**TX5X** or **TX5XX**) tempers when applicable.

(3) The former designation is shown in parenthesis where significantly different.

(4) High magnesium alloys 5456, 5083, and 5086 should be used in controlled tempers (**H111, H112, H116, H117, H323, H343**) for resistance to SCC and exfoliation.

(5) Alloys with magnesium content greater than 3.0 percent are not recommended for high temperature application, **66°C (150°F)** and above.

TABLE I
 ALLOYS WITH HIGH RESISTANCE TO STRESS CORROSION CRACKING
 (Continued)
COPPER ALLOYS

<u>CDA No.</u> (1)	<u>Condition (% Cold Rolled)</u> (2)	
110	37	
170	AT, HT (3)	
172	AT, HT (3)	
194	37	
195	90	
230	40	
422	37	
443	10	
510	37	
521	37	
524	0	
606	0	
619	40 (9% B phase)	
619	40 (95% B phase)	
638	0	CHG 1
655	0	
668	40	
704	0	
706	50	
710	0	
715	0	
725	40	CHG 1
752	50	

- (1) Copper Development Association alloy number,
 (2) Maximum percent cold rolled for which SCC data is available.
 (3) AT - Annealed and precipitation hardened.
 HT - Work hardened and precipitation hardened.

MSFC-SPEC-522B

TABLE I

ALLOYS WITH HIGH RESISTANCE TO STRESS CORROSION CRACKING

(Continued)

NICKEL ALLOYS

<u>Alloy</u>	<u>Condition</u>
Glass Seal 52 CR (51Ni-49Fe)	All
Invar 36 (36Ni-64Fe)	All
Hastelloy B	Solution Heat Treated
Hastelloy C	All
Hastelloy X	All
Incoloy 800	All
Incoloy 825	All
Incoloy 901'	All
Incoloy 903	All
Inconel 600 (1)	Annealed
Inconel 625	Annealed
Inconel 718 (1)	All
Inconel X-750	All
Monel K-500 (1)	All
Ni-Span-C 902	All
Rene' 41	All
Unitemp 212	All
Waspaloy	All

MISCELLANEOUS ALLOYS

<u>Alloy</u>	<u>Condition</u>
Beryllium S-200C	Annealed
HS 25 (L605)	All
HS 188 (1)	All
MP35N	Cold Worked and Aged
MP159	Cold Worked and Aged
Titanium 3Al-2.5V	All
Titanium 5Al-2.5Sn	All
Titanium 6Al-4V	All
Titanium 10Fe-2V-3Al	All
Titanium 13V-11Cr-3Al	All
Titanium IMI 550	All
Magnesium M1A	All
Magnesium LA141	Stabilized
Magnesium LA2933	All

(1) Including weldments

1 CHG 1

MSFC-SPEC-522B

TABLE II

ALLOYS WITH MODERATE RESISTANCE TO STRESS CORROSION CRACKINGSTEEL ALLOYS

<u>Alloy</u>	<u>Condition</u>
Carbon Steel (1000 Series)	180 to 200 ksi UTS
Low Alloy Steel (4130, 4340, D6AC, etc.)	180 to 200 ksi UTS
Nitronic 60	Annealed
400 Series Martensitic Stainless Steel (except 440)	(1)
AM350 Stainless Steel	Below SCT 1000
AM355 Stainless Steel	Below SCT 1000
Custom 450 Stainless Steel	Below H1000
Custom 455 Stainless Steel	Below H1000
PH13-8Mo Stainless Steel	All
15-5PH Stainless Steel	Below H1000
17-4PH Stainless Steel	All

- (1) Tempering between 700 and 1100°F shall be avoided because corrosion and stress corrosion cracking resistance is lowered.

MAGNESIUM ALLOYS

<u>Alloy</u>	<u>Condition</u>
AZ31B	All
ZK60A	All

MSFC-SPEC-522B

TABLE II

ALLOYS WITH MODERATE RESISTANCE TO STRESS CORROSION CRACKING

(Continued)

ALUMINUM ALLOYS (1) (2)Wrought

Alloy	Condition
2024 Rod, Bar, Extrusion	T6, T62
2024 Plate, Extrusions	T8
2124 Plate	T8
2048 Plate	T8
4032	T6
5083	A11 (3)
5086	A11 (3)
5456	A11 (3)
7001	T75, T76
7049	T76
7050	T736, T76
7075	T76
7175	T736, T76
7475	T76
7178	T76

(1) Mechanically stress relieved products (TX5X or TX5XX) should be specified where possible.

(2) Sheet, unmachined extrusions, and unmachined plate are the most resistant forms.

(3) Except for **the controlled** tempers listed in Footnote 4 of Table 1, Aluminum Alloys. These alloys are not recommended for high temperature application, 66°C (150°F) and above. | **CHG!**

TABLE III

ALLOYS WITH LOW **RESISTANCE** TO STRESS CORROSION CRACKINGSTEEL ALLOYS

<u>Alloy</u>	<u>Condition</u>
Carbon Steel (1000 Series)	Above 200 ksi UTS
Low Alloy Steel (4130, 4340, D6AC, etc.)	Above 200 ksi UTS
H-11 Steel	Above 200 ksi UTS
4340M	All
440C Stainless Steel	All
18 Ni Maraging Steel, 200 Grade	Aged at 900°F
18 Ni Maraging Steel, 250 Grade	Aged at 900°F
18 Ni Maraging Steel, 300 Grade	Aged at 900°F
18 Ni Maraging Steel, 350 Grade	Aged at 900°F
PH15-7-Mo Stainless Steel	All except CH900
17-7 PH Stainless Steel	All except CH900

ALUMINUM ALLOYS (1), (2)

<u>Wrought</u>		<u>Cast</u>	
<u>Alloy</u>	<u>Condition</u>	<u>Alloy</u>	<u>Condition</u>
2011	T3, T4	295.0 (195)	T6
2014	All	8295.0 (B195)	T6
2017	All	520.0 (220)	T4
2024	T3, T4	707.0 (607, Ternalloy 7)	T6
2024 Forgings	T6, T62, T8	D712.0 (D612, 40E)	As Cast
2024 Plate	T62		
Al-Li 2090	T8E41		
2219	T3, T4		
BS L93	T6		
7001	T6		
7005	All		
7039	All		
7075	T6		
7175	T6		
7079	T6		
7178	T6		
7475	T6		

- (1) Mechanically stress relieved products (**TX5X** or **TX5XX**) should be specified where possible.
- (2) Sheet, unmachined extrusions, and unmachined plate are the least susceptible forms.

TABLE III
 ALLOYS WITH LOW RESISTANCE TO STRESS **CORROSION** CRACKING
 (Continued)

COPPER ALLOYS

<u>CDA No. 1</u> ⁽¹⁾	<u>Condition</u> ⁽²⁾ <u>% Cold Rolled</u>
260	50
353	50
443	40
672	50, Annealed
687	10, 40
762	A, 25, 50
766	38
770	38, 50, Annealed
782	50

(1) Copper Development Association Alloy Number.

(2) Rating based on listed conditions only.

MAGNESIUM ALLOYS

<u>Alloy</u>	<u>Condition</u>
AZ61A	All
AZ80A	All

MSFC-SPEC-522B

APPENDM A

LIST OF SELECTED REFERENCES ON STRESS CORROSION

1. **Sprowls, D. O.** ; and Brown R. H., "**Resistance of Wrought High-Strength Aluminum Alloys to Stress Corrosion**," Technical Paper #17, Aluminum Company of American 1962.
2. **Spuhler, C. H.** and Burton, C. L., "Avoiding Stress **Corrosion** Cracking in High Strength Aluminum Alloy **Structures**," Aluminum Company of America, August 1, 1962
3. **Rutemiller, H. C.** and **Sprowls, D. O.**, "Stress Corrosion of **Aluminum** - Where **to Look for it**, How to Prevent **it**," Paper presented at 18th Conference **and Corrosion Show** of N. A. C. **E.**, March 19-23, 1962.
4. "Stress Corrosion **Cracking** in Aircraft Structural Materials, " **AGARD Conference Proceedings** Series No, 16, April 18 and 19, 1967.
5. Logan, H. L., "**The Stress-Corrosion** of Metals," John Wiley and Sons, **Inc.**, New York, 1966.
6. Humphries, T. S. and Nelson, E. **E.**, "**Stress** Corrosion Cracking Evaluation of Several Ferrous and Nickel Alloys," **April 2, 1970** NASA **TMX-64511**!
7. Williamson, James **G.**, "**Stress** Corrosion Cracking of **Ti-6Al-4V** Titanium Alloy in **Various Fluids**," November 19, 1969. NASA **TMX-53971**.
8. Humphries. T. **S.** and Nelson, E. **E.**, "**Stress** Corrosion Cracking Evaluation of Several Precipitation Hardening Stainless Steels," September 12, 1969. NASA TMX-53910
9. Humphries, T. **S.**, "Procedures for Externally Loading and Corrosion Testing Stress Corrosion Specimens," June 29, 1966. NASA TMX-63483
10. **Williamson, J. G.**. "Stress Corrosion Studies of AM-355 Stainless **Steel**," August 9, 1965. NASA **TMX-53317**
11. Humphries, **T.S.**, "Stress Corrosion of High-Strength Aluminum **Alloys**," June 24, 1963. NASA **MTP-P&VE-M-63-8**.
12. Humphria, T. S. and Nelson, E. **E.**, "Stress Corrosion **Cracking** **Susceptibility** of 18 **Ni Maraging** Steel," April 1974. NASA TMX-64837

MSFC-SPEC-522B

APPENDIX A (CONTINUED)

13. "Chloride Stress Corrosion Susceptibility of High-Strength Stainless Steel Titanium Alloy and Superalloy Sheet," Douglas Aircraft Co., Request No. ML-TDR-64-44, Vol. I and II March and May 1964.
14. "An Evaluation of High Strength Steel Forgings," General Dynamics, Report No. RTD TDR-63-4050, May 1964.
15. "Stress Corrosion Cracking of High Strength Alloys," Aerojet-General Corp., Report No. DA-04-495-ORD-3069, August 1961.
16. Bloom, F.K., "Stress Corrosion Cracking of Hardenable Stainless Steels," Armco Research Laboratories, Corrosion, Vol. **II**, August 1955.
17. Kaltenhauser, R.H., "Stress Corrosion Resistance of AM-350," Allegheny Ludlum Steel Corp. Report No. SS-450, October 1961.
18. Leckie, H.P. and Loginow, A.W., "Stress Corrosion Behavior of High Strength Steels," U.S. Steel Corp., Corrosion, Vol. 24, No. 9, September 1968.
19. Loginow, A.W., "Stress Corrosion Cracking of Austenitic Stainless Steel in Marine Environment," U.S. Steel Corp., Unpublished Memorandum, June 11, 1965.
20. Nelson, E.E., "Stress Corrosion Cracking of Several High Strength Ferrous and Nickel Alloys," November 11, 1971, NASA TMX-64626.
21. Popplewell, J.M., and Gearing, T.V., "Stress Corrosion Resistance of Some Copper Base Alloys in Natural Atmospheres," Olin Metals Research Laboratories, Corrosion, Vol. 31, No. 8, August 1975.
22. Logan, H.L., and Hessing, H., "Stress Corrosion of Wrought Magnesium Base Alloys," Part of Journal of Research of the National Bureau of Standards Research Paper RP 2074, Volume 44, March 1950.
23. Bond, A.P., Marshall, J.D., and Dundas, H.J., "Resistance of Ferritic Stainless Steels to Stress Corrosion Cracking," Stress Corrosion Testing, ASTM STP 425, Am. Soc. Testing Mats., 1967.
24. Reinhart, F.M., "Corrosion of Materials in Hydrospace," Part IV-Copper and Copper Alloys, Naval Civil Engr. Lab., Tech. Note N-961, April 1968.
25. Carter, C.S., et al "Stress Corrosion Properties of High Strength Hardening Stainless Steels," Corrosion, Vol. 27, No. 5, May 1971.

MNFC-SPEC-522B

APPENDIX A (CONTINUED)

26. Staley, J.T., "Comparison of Aluminum Alloys 7050, 7049, MA52, and 7175-T736 Die Forging," Alcoa Laboratories, AFML-TR-73-34, May 1973.
27. Humphries, T.S. and Nelson, E.E., "Stress Corrosion Cracking Susceptibility of 18 Ni Maraging Steel, April 1974, NASA TMX-64837.
28. Sedricks, A.J., "Comparative Stress Corrosion Cracking Behavior of Austenitic Iron Base and Nickel Base Alloys," Corrosion, Vol. 31, No. 9, September 1975.
29. Montano, J.W., "The Stress Corrosion Resistance and the Cryogenic Temperature Mechanical Behavior of 18-3Mn (Nitronic 33) Stainless Steel Parent and Welded Material," June 1976, NASA TMX-73309.
30. Montano, J.W., "The Stress Corrosion Resistance and the Cryogenic Temperature Mechanical Properties of Hot Rolled Nitronic 60 Bar Material, January 1977, NASA TMX-73359.
31. Montano, J.W., "The Stress Corrosion Resistance and the Cryogenic Temperature Mechanical Properties of Annealed Nitronic 32 Bar Material," April 1977, NASA TMX-73375.
32. Humphries, T.S., "Stress Corrosion Cracking of Martensitic Precipitation Hardening Stainless Steel," January 1980, NASA TM-78257.
33. Humphries, T.S., "Evaluation of the Stress Corrosion Cracking Resistance of Several High Strength Low Alloy Steels," May 1980, NASA TM-78276.
34. Humphries, T.S., "Seacoast Stress Corrosion Cracking of Aluminum Alloys," January 1981, NASA TM-82393.

MSFC-SPEC-522B
APPENDIX B

23

MATERIAL USAGE AGREEMENT				C	USAGE AGREEMENT NO.:	REV	PAGE OF	
PROJECT:		SYSTEM:		SUBSYSTEM:		ORIGINATOR:		ORGANIZATION/CONTRACTOR
PART NUMBER(S)		USING ASSEMBLY(S)		ITEM DESCRIPTION		ISSUE		
MATERIAL DESIGNATION			MANUFACTURER		SPECIFICATION		PROPOSED EFFECTIVITY	
MATERIAL CODE			LOCATION		ENVIRONMENT			
THICKNESS	WEIGHT	EXPOSED AREA	HABITABLE	<input type="checkbox"/>	PRESSURE PSIA	TEMPERATURE, °F	MEDIA	
			NONHABITABLE	<input type="checkbox"/>				
APPLICATION								
RATIONALE:								
ORIGINATOR:			PROGRAM MANAGER:			DATE:		
MATERIALS APPLICATIONS EVALUATION BOARD DISPOSITION								
				DATE	APPROVE	REJECT	DEFER	MAEB MEMO NR.
CHIEF, EH02:								EFFECTIVITY
SECRETARY:								
REMARKS:								

MSFC-SPEC-522B

APPENDIX C

STRESS CORROSION EVALUATION FORM

1. Part Number _____
2. Part Name _____
3. Next Assembly Number _____
4. **Manufacturer** _____
6. **Material** _____
6. Heat **Treatment** _____
7. Size and Form _____
8. Sustained Tensile Stresses-Magnitude and **Direction**
 - a. Process Residual _____
 - b. Assembly _____
 - o. **Design, Static** _____
9. **Special Processing** _____
10. **Weldments**
 - a. **Alloy** Form, Temper of Parent **Metal** _____
 - b. Filler Alloy if none, **indicate** _____
 - c. Welding Process _____
 - d. Weld **Bead** Removed - Yes (), No () _____
 - e. Post-weld Thermal **Treatment** _____
 - f. Post-Weld Stress Relief _____
11. Environment _____

MSFC-SPEC-522B

APPENDIX C (CONTINUED)

- 12. **Protective Finish**_____
- 13. **Function of Part**_____

- 14. **Effect of Failure**_____

- 15. **Evaluation of Stress Corrosion Susceptibility**_____

- 16. **Remarks:**_____

MSFC- SPEC- 522B

APPENDIX C (CONTINUED)

- 1-4. **Part Identification** - Information identifying specific part being evaluated. These headings may be modified as needed.
5. **Material** - Material should be identified as specified on drawing. Specific alloy and temper designation of raw material from which part is fabricated should be given.
6. **Heat Treatment** - All thermal treatments which the part receives should be listed.
7. **Size and Form** - Approximate dimensions of raw material from which part is fabricated should be listed. The raw material form (bar, plate, sheet extrusion, forgings, etc.) should also be shown.
8. **Sustained Tensile Stresses** - An estimation of all sustained tensile stresses should be made. The stresses should be listed according to their source (8a. Process, b. Assembly, c. Design) and the basis on which the estimation was made. Any special precautions taken to control stresses should be noted.
9. **Special Processing** - Any processes used for reducing tensile stresses (such as shot peening or stress relief treatments) should be noted.
10. **Weldments** - An SCC evaluation should be made of all weldments and all information that may assist in the evaluation should be submitted. The alloy, form, and temper of the parent metal, filler alloy if any, welding process, weld bead removed, post-weld thermal treatment or stress relief as listed in 10a. through 10f. is the type of information required.

Environment - An evaluation should be made as to the corrosive environment to which the part will be exposed during its lifetime. This includes exposure during fabrication, assembly, and component storage as well as environmental conditions during use.

Protective Finish - Any finishes which are applied for corrosion protection or finishes which might affect the basic corrosion resistance of the component should be listed.

13. **Function of Part** - The basic function of the part (or if more pertinent the assembly) should be listed.

MSFC-SPEC-522B

APPENDIX C (CONTINUED)

14. Effect of **Failure** - List the **possible** effect **that failure** of the part (or **assembly**) will have on the over all **function or mission** of the major **assembly involved**.
16. **Evaluation of Stress Corrosion Susceptibility** - This should **include** the **rationale on** which the **material selection was made** and a short **explanation as to** why no **stress** corrosion problem **is expected**.
16. Remarks - Any **additional** information or **explanatory** notes not otherwise listed should be **included**.