



Langley Research Center

**LPR 8739.21**

**Effective Date: April 13, 2011**

**Expiration Date: March 31, 2016**

# Langley Research Center (LaRC) Procedures and Guidelines for Electrostatic Discharge (ESD) Control of ESD-Sensitive (ESDS) Devices Program

**National Aeronautics and Space Administration**

April 13, 2011

LPR 8739.21

**Responsible Office: Safety and Mission Assurance Office (SMAO)****TABLE OF CONTENTS**

P.1 Purpose.....	6
P.2 Applicability.....	6
P.3 Authority .....	6
P.4 Applicable Documents .....	7
P.5 Measurement/Verification .....	8
P.6 Cancellation .....	8
<b>1 GENERAL .....</b>	<b>9</b>
1.1 Configuration Control .....	9
1.2 Implementation.....	9
1.3 Records.....	10
<b>2 ESD CONTROL PROGRAM .....</b>	<b>11</b>
2.1 General .....	11
2.2 ESD Technical Overview .....	11
2.3 ESD Sensitivity Levels.....	12
2.4 Declaring the Model and Class Required.....	14
2.5 Personnel Safety .....	14
2.6 ESD Control Program POC.....	14
2.7 ESD Program Monitor .....	15
2.8 EPA .....	15
2.9 Temporary, Provisional and Intermittent-Use EPA .....	17
2.10 ESD Control Program .....	17
2.11 Audits and Inspections .....	18
<b>3 TRAINING AND CERTIFICATION PROGRAM .....</b>	<b>20</b>
3.1 PURPOSE .....	20
3.2 SCOPE .....	20
3.3 REQUIREMENTS .....	20
3.4 Training Program .....	22
3.5 Certification of Training Levels .....	23
3.6 Training Record Maintenance .....	23
3.7 Maintenance of Training and Certification .....	24
<b>4 ESD CONTROL REQUIREMENTS FOR FACILITIES .....</b>	<b>25</b>
4.1 General .....	25
4.2 Compliance.....	25
4.3 Traceability.....	25
4.4 Identification and Access - ESD Areas .....	26
4.5 Temporary Use of ESD Benches for Non-ESDS Work.....	27

April 13, 2011

LPR 8739.21

4.6 Prohibited Materials and Activities .....	28
4.7 ESD-Protective Work Surfaces .....	30
4.8 ESD-Protective Floor Surfaces .....	31
4.9 Personal Grounding Devices .....	31
4.10 Integrity Testing of Personal Grounding Devices .....	32
4.11 Equipment and Facilities .....	33
4.12 Hand Tools, Equipment, and Fixtures .....	37
4.13 Protective Packaging .....	38
4.14 Temperature Chambers and Cooling Agents .....	39
4.15 Cleaning and Cleaning Agents .....	40
4.16 Electrostatic Survey Meters, Voltmeters, and Monitors .....	40
4.17 Clothing Requirements .....	40
4.18 Orbit Replaceable Units (ORU) Requirements .....	41
<b>5 ESDS ITEM HANDLING.....</b>	<b>44</b>
5.1 General .....	44
5.2 Special Requirements for Highly Sensitive Items .....	44
5.3 Receiving, Internal Handling, and Shipping .....	47
5.4 Equipment Level Test, Maintenance, and Installation .....	47
5.5 Identification and Marking .....	47
<b>6 ASSURANCE PROVISIONS.....</b>	<b>49</b>
6.1 Surveillance .....	49
6.2 EPA “PASS” Certification Requirements .....	49
6.3 EPA Area “FAIL” Requirements .....	49

April 13, 2011

LPR 8739.21

## LIST OF APPENDICES

APPENDIX A	Definitions .....	51
APPENDIX B	Acronyms .....	54
APPENDIX C	EPA Verification Test Procedure .....	55

## LIST OF FIGURES

Figure 4-1:	Typical ESD Grounded Workstations .....	29
Figure 4-2:	Workstation Common Point Ground.....	29
Figure 4-3:	Main Service Box .....	34
Figure 5-1:	Sensitive Electronic Device Caution Symbol (with & without sensitivity class level) ....	48
Figure 5-2:	ESD Protective Item Symbol .....	48
Figure 5-3:	ESD Common Point Ground Symbol .....	48

## LIST OF TABLES

Table 1-1:	Record Retention; NPR 1441.1 .....	10
Table 2-1:	ESDS Component Sensitivity Classifications – HBM .....	13
Table 2-2:	ESDS Component Sensitivity Classifications – MM .....	13
Table 2-3:	ESDS Component Sensitivity Classifications – CDM .....	13
Table 4-1:	ESD Control Program Verification Schedule and Measurements.....	27
Table 4-2:	ESD Sensitivity for Selection and Performance of Air Ionizers .....	37
Table 5-1:	Summary of Requirements Applicable to HBM Class 0 and MM Class M1 .....	45

April 13, 2011

LPR 8739.21

## CHANGE HISTORY LOG

Status	Document Revision	Approval Date	Description
Baseline	A	4/13/2011	<b>Initial Release</b> <i>This document is derived from NASA-HANDBOOK 8739.21</i>

April 13, 2011

LPR 8739.21

## PREFACE

### P.1 Purpose

P.1.1 The National Aeronautics and Space Administration (NASA) quality requirements for Electrostatic Discharge (ESD) safety and control are contained in ANSI/ESD S20.20, ESD Association Standard for the Development of an Electrostatic Discharge Control Program for Protection of Electrical and Electronic Parts, Assemblies and Equipment (Excluding Electrically Initiated Explosive Devices).

P.1.2 This NASA Langley Research Center (LaRC) Procedural Requirement (LPR) sets the standard for the development of an ESD Control Program Plan (CPP) for all projects, or any portion of any external project, where the LaRC has the responsibility to build and handle ESD Sensitive (ESDS) hardware.

P.1.3 This LPR describes the responsibilities and requirements for establishing and maintaining an ESD CPP that meets or exceeds the ESD Association (ESDA) ANSI/ESD S20.20 requirements, and provides specific instructions pertaining to ESD standards related to personnel, laboratories, tools, equipment, training, and safety.

### P.2 Applicability

P.2.1 This LPR is applicable to all NASA LaRC personnel civil service and contractor, and to all support organizations on or off of the LaRC who are performing work on any high reliability aircraft, space flight, or mission critical work related to electrical and electronic parts, assemblies and equipment; excluding electrically initiated explosive devices.

*Note: NASA-STD-8739.7, Requirements for Electrostatic Discharge Control (ISO 9000)*

*Although NASA-STD-8739.7 has been canceled, it is still valid when invoked on contracts established before February 27, 2002.*

P.2.2 This LPR is provided as the NASA LaRC ESD CPP resource for all organizations that handle ESDS items for NASA projects and are subject to the requirements of ANSI/ESD S20.20.

P.2.3 This document applies to all facilities where NASA high reliability aircraft or space flight hardware will be processed; including Ground Support Equipment (GSE) electrical and mechanical (as well as lifting fixtures), and hardware production where the end item may not be mission-critical yet is expensive to replace, or is a long-lead acquisition item.

P.2.4 The practices described herein are generally suitable for the ESD sensitivity levels of the Human Body Model (HBM) Classes 0 and 1A and Machine Model (MM) Class M1.

P.2.5 For special instances where the Charge Device Model (CDM) applies, additional precautions and practices beyond those described herein may be necessary. See section 5.2.

P.2.6 The convention used in this document is as follows: **Shall** - Used to indicate a binding requirement, **Should** - Used to indicate a desired goal, **Will** - Used to indicate a statement of fact.

### P.3 Authority

P.3.1 NPD 1400.1, Documentation and Promulgation of Internal NASA Requirements.

April 13, 2011

LPR 8739.21

P.3.2 NASA Notice of Cancellation of NASA-STD-8739.7, which directs each NASA Center to obtain its own ESD CPP.

#### P.4 Applicable Documents

- a. NPD 8730.5, NASA Quality Assurance Program Policy
- b. NPR 1441.1, NASA Records Retention Schedules
- c. NASA-STD-4003, Electrical Bonding for NASA Launch Vehicles, Spacecraft, Payloads, and Flight Equipment
- d. NASA HANDBOOK 8739.21, Workmanship Manual for Electrostatic Discharge Control
- e. ANSI/ESD S20.20, ESD Association Standard for the Development of an Electrostatic Discharge Control Program for – Protection of Electrical and Electronic Parts, Assemblies and Equipment (Excluding Electrically Initiated Explosive Devices) NOTE: all references herein to ANSI/ESD S20.20 are to the 2007 version unless otherwise specified.
- f. ANSI/ESD S4.1, Worksurfaces–Resistance Measurements
- g. ANSI/ESD S541-2008, Packaging Materials for ESD Sensitive Items
- h. ANSI/ESD S6.1-2005, Grounding
- i. ANSI/ESD SP3.3, Periodic Verification of Air Ionizers
- j. ANSI/ESD STM2.1, Garments – Resistive Characterization
- k. ANSI/ESD STM5.1, Human Body Model (HBM) – Component Level
- l. ANSI/ESD STM5.2, Machine Model (MM) – Component Level
- m. ANSI/ESD STM5.3-1, Charged Device Model (CDM) – Component Level
- n. ANSI/ESD STM12.1, Seating – Resistive Measurement
- o. ANSI/ESD TR20.20-2008, Electrical Hand Tools
- p. ESD ADV1.0, ESDA Glossary of Terms
- q. ESD STM7.1, Resistive Characterization of Materials – Floor Materials
- r. ESD STM13.1, Electrical Soldering/De-soldering Hand Tools
- s. ESD TR20.20-2008, Handbook for the Development of an Electrostatic Discharge Control Program for the Protection of Electronic Parts, Assemblies and Equipment
- t. ESD TR53-01-06, Compliance Verification of ESD Protective Equipment and Materials
- u. JPL D-1348, JPL Standard for Electrostatic Discharge (ESD) Control
- v. JPR 8730.1, Electrostatic Discharge Control Requirements for the Protection of Electronic Components and Assemblies
- w. LPR 1710.4, Personal Protection-Clothing and Equipment
- x. LF 21, ESD Control Program Certification Log
- y. LF 22, Wrist Straps/Footwear/Hand Tools Logs

April 13, 2011

LPR 8739.21

- z. LF 23, ESD Protected Area Test Log
- aa. LF 382, Certification/Verification Sticker
- bb. LF 385, ESD Protected Area “Out of Service” Sign
- cc. LF 120, Certification of Training
- dd. LF 126, Laboratory Daily Humidity Log

**P.5** Measurement/Verification

Methods for personnel verification are listed in section 3. Methods for equipment verifications are listed in appendix C, section 5.

**P.6** Cancellation

None

*Original signed on file*

Stephen G. Jurcyk

Deputy Director

Distribution:

Approved for public release via the Langley Management System; distribution is unlimited.



April 13, 2011

LPR 8739.21

## 1 GENERAL

### 1.1 CONFIGURATION CONTROL

1.1.1 This LPR is controlled and enforced by the LaRC Safety and Mission Assurance Office (SMAO).

1.1.2 Requests for technical or content changes shall be processed in accordance with NASA LaRC LMS document control change procedures.

### 1.2 IMPLEMENTATION

1.2.1 This LPR includes requirements on facility preparations and certifications, records management, minimum qualifications and training of the responsible personnel, guidance for assessing the sensitivity of the hardware to be handled, and the declaration and execution of special processes/ criteria as applicable.

1.2.2 The NASA LaRC SMAO will assign an ESD Point of Contact (POC) that can advise and assist Operators, Program Monitors, Contractors, and other authorized personnel in the proper and effective implementation of the provisions of this LPR.

a. The ESD POC shall verify the compliance of the LaRC ESD CPP, as required by ANSI/ESDA S20.20-2007.

1.2.3 The requirements contained herein shall be implemented by all personnel including Operators, Program Monitors, Audit Teams, Audit Coordinators, and the LaRC ESD POC.

1.2.4 The hardware designer, based on the most sensitive/vulnerable component to be protected, in coordination with the SMAO POC, shall determine the adequate ESD Protected Area (EPA) certification level and associated ESD event model to be used.

a. The typical default EPA certification level is HBM Class 1A (See Table 2-1).

b. Where the HBM does not provide sufficient protection for the hardware, the MM or the CDM should be considered when designing the EPA (see 2.3).

c. For areas required to protect extremely sensitive devices (see 5.2).

1.2.5 The requirements herein facilitate compliance to NASA Agency-level ESD requirements; however, these requirements do not supersede or preclude Project review and approval of external suppliers' ESD CPP for compliance with ANSI/ESD S20.20.

a. The Project's Contracting Officer shall assure that Project Suppliers' ESD CPPs meet the requirements of ANSI/ESD S20.20 as well as any Project-specific ESD requirements.

b. Projects shall use this LPR as a benchmark against which external suppliers' plans are evaluated.

April 13, 2011

LPR 8739.21

**1.3 RECORDS**

Records required by the processes described herein shall be retained per Table 1-1 below.

**Table 1-1: Record Retention; NPR 1441.1**

<b>Record Title</b>	<b>Record Custodian</b>	<b>Retention</b>
Training records	Office of Human Resources and/or Supervisor.	NPR 1441.1; 1/22B – Temporary – Destroy 2 years after employee discontinues or completes training.
ESD Workstation Records: ESD Control Program – Certification Log: LF 21 Check Log: LF 22 EPA Test Log: LF 23	Laboratory Manager or owning project manager when there is no Program Manager	NPR 1441.1; 8/103 & 8/107 -Temporary- Destroy/delete when between 5 & 30 years after program/project termination. Do not retain longer than life of program/project plus 5 years.
Temporary/Intermittent Workstation records: ESD Control Program – Certification Log: LF 21 Check Log: LF 22 EPA Test Log: LF 23	Project Manager	NPR 1441.1; 8/109 -Temporary- Destroy/delete when between 2 & 15 years old. Do not retain longer than life of program/project plus 5 years.

April 13, 2011

LPR 8739.21

## 2 ESD CONTROL PROGRAM

### 2.1 GENERAL

2.1.1 The requirements contained within this LPR meet or exceed the requirements of ANSI/ESD S20.20 to include the NASA ESD Workmanship requirements for processing ESD sensitive equipment.

2.1.2 Proper control of ESD is critical at every process step from electronic part manufacturing through testing and shipment, to incorporation on printed wiring boards, electronic modules, and directly into boxes, to final installation or integration.

### 2.2 ESD TECHNICAL OVERVIEW

2.2.1 If not properly addressed, ESD could be a formidable threat to active components.

2.2.2 Proper preparations and handling are necessary to prevent damage during different phases of development, fabrication, installations, packaging and transportation, and assembly.

2.2.3 ESDS components shall be clearly marked ESDS.

2.2.4 All personnel and facilities shall be prepared to take precautions and follow best practice procedures to avoid an ESD event.

*NOTE: A good example of an ESD event is the discharge experienced when touching the metal doorknob on the way out of a carpeted room. Charge accumulates by friction. Temperature, dryness, and other conditions contribute to the level of charge accumulated on the body. The “zap” experienced and heard is a form of ESD discharge. ESD is the transfer of electrostatic charge between bodies with an electrical potential difference.*

2.2.5 In general, there are three methods of charge generation when considering the basics of *static electricity*.

- a. Triboelectrification: the phenomena that produces electrostatic charges by friction. Although the name comes from the Greek word “tribos” for “rubbing” of materials, the two materials just need to come into contact for electrons to be exchanged; charge is generated when the two materials separate. For example, two atoms of different materials may each have a neutral charge until contact-separation occurs, by which one atom may lose one electron from its outer most shell to the outer most shell of the other, leaving one atom positively charged and the other negatively charged.
- b. Induction by itself merely polarizes one object by a charged object; an example would be a positively charged rod polarizing a gold-leaf electroscope. The electroscope remains neutral unless the top plate becomes momentarily grounded, i.e. by touching it with a finger. The electrons from ground will flow into the polarized electroscope, leaving the electroscope negatively charged when the ground connection is removed.
- c. Conduction charging occurs when a charged object makes contact with a neutral object, and therefore transfers its  $\pm$  charge. A negative object will transfer electrons to the neutral object; a positive object will pull electrons from the neutral object. One example is a person with a

April 13, 2011

LPR 8739.21

built-up static charge on his body, and discharging that energy into a printed circuit board (PCB) through his finger by pointing too closely to the board.

2.2.6 Conductive objects can become electrostatically charged if not properly grounded. If an ESD event occurs in the proximity of an ESDS device, damage can occur. Charge is not localized on the surface of a conductor, but is spread out uniformly over the conductor's surface. Thus, very low voltages are capable of damaging ESDS devices.

2.2.7 Cathode ray tubes and other high voltage electric devices can create high electrical field potentials. Exposing ESDS components through such a field can induce internal currents causing damage even if the device does not come in direct contact with the charged surface.

2.2.8 Precautions [for a slow controlled discharge] are taken when grounding a device that is suspected of becoming charged by an external electrostatic field.

2.2.9 Packaging of Integrated Circuits (ICs), and modern sophisticated avionics and sensing components are extremely small and continue to shrink in size as technology advances. This trend increases the ESD vulnerability of these devices because slight charges accumulate on these conductive elements that can easily exceed the breakdown potential of the insulating layers or the air gaps between them, causing irreparable damage. The presence of physical damage, such as fine scratches or contaminants within and on the surface of the device, tends to increase ESD sensitivity.

2.2.10 Inside a clean room, requirements of contamination control may place restrictions on the approaches that ordinarily are available for controlling ESD.

2.2.11 The smallest ESD event most people can detect is about 2,000 volts. A similar voltage level, when applied to an ESDS device, can result in catastrophic failure. Some parts are severely damaged by ESD events in the orders of tens of volts. Therefore, many ESD destructive events are not noticeable by human detection alone.

2.2.12 Three general ESD damage failure modes can be defined:

- a. Catastrophic failure: When a catastrophic failure occurs, the device does not function at all.
- b. Parametric failure: When a parametric failure occurs, the device has been slightly damaged so that it still performs, but not to specification.
- c. Latent failure: When a latent failure occurs, the device has been stressed, but it does not fail immediately upon exposure. The device continues to perform within acceptable tolerance limits, but is likely to fail later.

2.2.13 Both catastrophic and parametric failures are usually found during product testing, where isolation and replacement are possible.

2.2.14 Latent failures remain undetected during routine system testing and product development.

## 2.3 ESD SENSITIVITY LEVELS

2.3.1 The ESD sensitivity of devices is determined using three different electrical models: the HBM, the MM, and the CDM.

April 13, 2011

LPR 8739.21

2.3.2 Device classification using any of the electrical model Classes in Table 2-1, 2-2, or 2-3 indicates that the device will not be damaged by that type of discharge, with an energy level that relates to the voltage level shown for that Class level.

- a. HBM: This simulates the discharge from the fingertip of an Operator to an electronic component. In the HBM, a 100-pF capacitor is discharged through a 1500-ohm resistor to ground.

**Table 2-1: ESDS Component Sensitivity Classifications – HBM**

Class	Voltage Range
0	<250 V
1A	250 to <500 V
1B	500 to <1000 V
1C	1000 to < 2000 V
2	2000 to <4000 V
3A	4000 to <8000 V
3B	≥8000 V

- b. MM: This model originated in Japan as a worst-case HBM. It is a faster discharge model, designed to simulate ESD events in automatic handling and testing equipment. In this model, a 200-pF capacitor is discharged directly to ground.

**Table 2-2: ESDS Component Sensitivity Classifications – MM**

Class	Voltage Range
M1	<100 V
M2	100 to <200 V
M3	200 to <400 V
M4	≥400 V

- c. CDM: This model considers the situation where a device is charged and then discharged to ground through one pin or connector. The CDM sensitivity of a given device may be package dependent.

**Table 2-3: ESDS Component Sensitivity Classifications – CDM**

Class	Voltage Range
C1	<125 V
C2	125 to <250 V
C3	250 to <500 V
C4	500 to <1000 V
C5	1000 to <1500 V
C6	1500 to <2000 V
C7	≥2000 V

April 13, 2011

LPR 8739.21

## 2.4 DECLARING THE MODEL AND CLASS REQUIRED

2.4.1 The EPA shall be designed and verified to an ESD Sensitivity level by the ESD Program Monitor; see section 2.7 below for a full description of this person's duties.

2.4.2 This rating shall be specified in the EPA's engineering documentation and will be determined by one of the following methods:

- a. Assuming that all ESD products have an HBM sensitivity of 100 volts.
- b. Actual testing of products using accepted test methods.
- c. Referencing ESD part test data in published documents.
- d. Or use an alternate option listed in ANSI/ESD S20.20 Table 2 when the previous three options are considered neither cost effective nor technically viable.

2.4.3 The ESD POC shall certify the EPA based on the ESD model and Class level reported by the ESD Program Monitor.

2.4.4 The most sensitive device to be handled during processing shall dictate the minimum protection afforded by the EPA.

*NOTE: Parts mounted in high-level assemblies are usually less sensitive. The recommended default EPA certification level is HBM Class 1A (see Table 2-1 and section 2.8).*

2.4.5 Design, maintenance, and certification of HBM Class 0 EPAs can be costly. Use of the HBM Class 0 level should only be done as dictated by the sensitivity of the hardware being processed

## 2.5 PERSONNEL SAFETY

2.5.1 The procedures and equipment described in this document may expose personnel to hazardous electrical conditions.

- a. Users of this LPR shall comply with all applicable laws, regulatory codes, and both external and LaRC internal applicable safety procedures.
- b. Users are cautioned that this document alone does not replace or supersede any requirements for personnel safety.

2.5.2 Ground fault circuit interrupters (GFCI) and other electrical safety procedures shall be used whenever personnel might come into contact with electrical sources.

2.5.3 Electrical hazard reduction practices shall be exercised.

2.5.4 Proper grounding shall be followed.

## 2.6 ESD CONTROL PROGRAM POC

2.6.1 The ESD POC shall be the primary point of contact and responsible party for ESD plan implementation.

April 13, 2011

LPR 8739.21

2.6.2 The POC is responsible for:

- a. Produce, submit, and execute the ESD CPP that is traceable to the applicable requirements of ANSI/ESD S20.20
- b. Verify Langley's compliance with this ESD CPP.
- c. Certify new EPAs.
- d. Recertify expired or failed EPAs.
- e. Maintain records of EPA certification.
- f. Periodically audit certified EPAs.
- g. Maintain a record of audits performed.
- h. Report results of certifications and audits to the proper ESD Program Monitors.
- i. Report results of certifications and audits to upper management.

## 2.7 ESD PROGRAM MONITOR

2.7.1 The organization responsible for an EPA shall designate an ESD Program Monitor for that area.

- a. ESD Program Monitors may be responsible for more than one EPA.

2.7.2 The ESD Program Monitor is responsible for:

- a. EPA maintenance.
- b. ESD signage in the area.
- c. Scheduled EPA verifications.
- d. Random inspections and audits of EPAs.
- e. Up-to-date verification records (logs) and maintenance records.
- f. Reactivation of EPAs with less than 6 months of inactivity.
- g. Transfer of records during project transitions.
- h. Monitoring and maintenance of additional protective measures when needed to meet specialty certification requirements for handling highly sensitive devices.
- i. Authorization to use EPAs (except Class 0 rated EPAs) for non-ESDS work.
- j. Verification and reactivation of an EPA after it was used for non-ESDS work.
- k. Notifying ESD POC of any deviations sought against this LPR, and providing that person with a copy of the tailored document.

## 2.8 EPA

2.8.1 An EPA may be a single workstation, laboratory, room, or building, or any area with pre-defined boundaries, that is designed to limit damage to electrical hardware by ESD events.

April 13, 2011

LPR 8739.21

2.8.2 EPAs may be permanent or temporary.

2.8.3 When an EPA is not maintained, the ESD Program Monitor shall decommission it by marking the area as not approved for use with a LF 385.

2.8.4 If the area to be used has not been maintained for a period not to exceed six months, the ESD Program Monitor shall reactivate the area by verifying that the area passes the tests in Table 4-1, by affixing a LF 382, Certification/Verification Sticker, and by initiating a LF 21 Area Test Log (ATL).

2.8.5 When an EPA has been decommissioned and marked as not approved for use for a period exceeding six months it must be considered “abandoned.”

- a. Activation of an abandoned area shall be accomplished via certification by the ESD POC, to the EPA ESD Control Items listed in Table 3 of the ANSI/ESD S20.20-2007.
- b. The ESD Program Monitor shall properly mark the status of abandoned workstations if they may be mistaken for active EPAs.

2.8.6 Certified EPAs can protect ESD sensitive parts, assemblies and equipment that are without ESD-protective covering or packaging; however, ESDS devices shall not be transported away from the EPA, or between EPAs, without using ESD-safe packaging or carriers due to the risks of ESD damage.

2.8.7 The ESD POC shall initially certify all EPAs and recertify them as needed (see section 2.6 and Appendix C). The following are prerequisites for EPA certification:

- a. Personnel carry current certification.
- b. A control program for verification records is instituted.
- c. EPA environment measurements are up to date and meet Class level requirement (see 4.12.1).
- d. ESD workstation measurements are up to date and meet Class level requirement (see Table 4.1).

2.8.8 The ESD POC shall recertify EPAs when:

- a. Rewiring of the area has occurred.
- b. New work areas are added or moved.
- c. New features are added, such as a new conductive floor or an upgrade to a Continuous Monitoring System (CMS).
- d. An abandoned EPA is reactivated.
- e. An ESD failure is traced to the particular ESD protected Workstation.

2.8.9 The ESD Program Monitor shall use LF 21 Certification Log to record the certification data.

- a. The ESD Program Monitor shall use proper identification stickers to indicate the compliance of all benches, chairs, stools, shelving, microscopes, wrist straps, foot straps, and other grounding devices.



April 13, 2011

LPR 8739.21

2.8.10 Once certified by the ESD POC, certification of an EPA shall be maintained via scheduled inspections, which will be performed by the assigned ESD Program Monitor.

- a. EPA certification is voided if the scheduled verification is not performed for more than 6 consecutive months, or if any of the conditions in Paragraph 2.8.8 above have been encountered. Also see paragraph 6.2.2.

2.8.11 The ESD Program Monitor shall ensure that all verification equipment is calibrated to the manufacturer's specifications and kept up to date in order to properly execute an EPA certification/recertification.

## **2.9 TEMPORARY, PROVISIONAL AND INTERMITTENT-USE EPA**

2.9.1 Temporary EPAs are areas created for use while working on a specific project for a continuous period of less than 3 months (1 month if they are Class 0).

- a. These areas shall be certified by the ESD POC for a specific period of time.
- b. The ESD POC shall store all verification records with the Project's Integration and Test (I&T) records.
- c. A long-term verification schedule requirement is not applicable to these types of EPAs; however, all other requirements would apply if the temporary EPA were converted to a permanent EPA.

2.9.2 Provisional EPAs are areas created for a one-time use only and where it is not practical to set up a temporary EPA.

- a. Provisional EPAs shall be the responsibility of the ESD POC.

2.9.3 The lack of certification and oversight associated with provisional EPAs makes them incompatible with applications that require handling items that require tighter controls and lower ESD voltage levels than the default HBM 1B (see Table 2-1).

2.9.4 Intermittent-Use of EPAs is defined as the use of a permanent EPA for periods lasting less than one month at a time, with longer periods of idle time.

- a. When not in use, the ESD Program Monitor shall mark intermittent-use EPAs as temporarily Out-of-Service.
- b. Following the idle period and prior to use, the ESD Program Monitor shall re-commission the EPA using standard verification methods (see Appendix C).
- c. These EPAs are not required to be recertified by the ESD POC as long as the idle period does not exceed 6 months.
- d. During idle periods, the ESD Program Monitor shall ensure that intermittent-use HBM Class 0 EPAs are not used for any other purpose and they are kept clean.

## **2.10 ESD CONTROL PROGRAM**

2.10.1 The NASA LaRC ESD POC shall use the following criteria when conducting internal audits:

- a. Verification that EPAs conform to the limits described in Table 4-1 prior to use.

April 13, 2011

LPR 8739.21

- b. Use of protective personnel clothing and proper personnel grounding at all necessary points where ESDS items will be handled.
- c. All personnel handling ESDS items have received the necessary training to the appropriate working level (Operator, ESD Program Monitor or Level B Instructor) and have current certification.
- d. Performance of audits and inspections to ensure the integrity of the EPAs and equipment in accordance with the requirements listed in Table 4-1. See section 2.11.
- e. Inspection of documentation for ESD markings, precautions and handling procedures, as applicable.
- f. Proper identification of ESDS items. .
- g. Handling of ESDS items only at approved EPAs.
- h. Description of field operations and precautionary procedures, when applicable, to prevent ESD damage.
- i. Maintenance of auditable records and documentation for all measurements required in Table 4-1.
- j. When several projects share an EPA, the original records are kept at the EPA and copies are distributed to each project as needed.
- k. Use within EPAs only of materials recognized by the ESD Association as ESD-protective materials (i.e., the material complies with ESD Association-recommended practices).

## **2.11 AUDITS AND INSPECTIONS**

2.11.1 General: The ESD Program Monitor shall be responsible for the following activities related to records:

- a. Maintain records regarding the EPA at the site.
- b. Use LF 23 for creating the area test log and recording data related to deficiencies, corrective actions and related verification and validation.

2.11.2 Audits: EPA certifications are achieved through audits that are performed by the ESD POC or on their behalf by an Audit Team or Audit Coordinator.

- a. Certification is based on yearly EPA audits.
- b. The ESD Program Monitor shall perform a self-audit of an EPA and provide the data to the ESD POC to meet this requirement for each year subsequent to the initial certification, which was done by the POC.

2.11.3 Inspections/Verifications: Program Monitors shall perform inspections of their EPA.

- a. The inspections consist of a general review of the area and records, as well as the verification described in Appendix C.

April 13, 2011

LPR 8739.21

- b. These inspections may be carried out any time the ESD Program Monitor deems them necessary to ensure continuous compliance of the EPA to the ESD assigned safety level.
- c. As a minimum, inspections shall be done concurrently with the verification tests (see Table 4-1).

2.11.4 New Projects: If a new Project takes over the EPA and the old records are not available, the ESD Program Monitor shall perform a re-verification of the EPA in accordance with Appendix C and for attaching new dated stickers to the applicable workstations.

April 13, 2011

LPR 8739.21

### 3 TRAINING AND CERTIFICATION PROGRAM

#### 3.1 PURPOSE

3.1.1 To teach and make personnel familiar with the NASA LaRC ESD CPP and to minimize both catastrophic and latent failures associated with an ESD event.

3.1.2 Successful completion of this NASA LaRC training program shall be achieved by those persons listed in section 3.2.1 who are involved in any of the functions listed in 3.3.3 prior to any flight, space flight, or mission critical work being performed.

#### 3.2 SCOPE

3.2.1 Training certification to this program shall apply to all NASA LaRC personnel civil service and contractor, and to all support organizations on or off of the LaRC who are performing work on any flight, space flight, or mission critical work related to electrical and electronic parts, assemblies and equipment; excluding electrically initiated explosive devices.

#### 3.3 REQUIREMENTS

3.3.1 The NASA LaRC ESD POC shall be responsible for the development of a classroom training module for each of the groups listed in section 3.3.3, below. It is recommended that each module be reviewed by an SMAO approved authority.

3.3.2 Training and certification shall be applicable to all personnel who perform or supervise any of the following ESD-related functions:

- a. Instruction.
- b. Design.
- c. Operator: handling, installation, maintenance and repair.
- d. Inspection and test.
- e. Procurement (only if handling or specifying ESDS materials), storage, shipping and receiving.
- f. Janitorial (only if responsible for cleaning in EPAs).

3.3.3 Prerequisites for personnel certification varies according to function.

3.3.4.1 All personnel who perform or supervise any of the previously listed functions shall be initially trained according to the instructor-lead Electrostatic Discharge (Basic) training module similar to GSFC WM-001, while the method for re-training shall be at the LaRC ESD POCs discretion – such as the use of the NASA Shared Services Center employee Training Plan's Intranet services.

3.3.4.2 The LaRC SMAO shall implement ESD training and provide a Level B instructor for classroom instruction.

3.3.4 ESD training instructors shall be certified based on their competency as instructors and their knowledge of the ESD CPP they are teaching.

April 13, 2011

LPR 8739.21

- a. A “Train the trainer” system can be used by the LaRC ESD POC to train larger numbers of “Level B” trainers, who in turn train Operators and Program Monitors.
- b. The ESD POC is a “Master” or “Level A” instructor.

3.3.5 It is not mandatory that design group personnel are trained in ESD unless they are also involved in either of the other groups previously listed in section 3.3.3.

- a. It is recommended that a thorough understanding of the cause and effects related to ESD is held by design group personnel, such that prevention practices will be incorporated into the design; today components are more densely populated and supply voltages are typically 5V or less, therefore increased awareness is beneficial to ESD control.
- b. The optional ESD certification for design group personnel shall be the same as that of Inspector.

3.3.6 Operators that handle ESDS devices shall pass the basic training module before being certified by their Program Monitor or their Trainer’s Supervisor, who can vouch for their competent ability to work on final hardware.

- a. Operators shall demonstrate a thorough understanding of ESD prevention, while performing hands-on work to ESDS devices within an EPA.

3.3.7 Personnel performing inspections and/or conducting tests shall be certified according to the basic training module designed for Operators, but without the hands-on prerequisite.

3.3.8 Personnel who handle ESDS items that remain packaged include those groups of procurement, storage, shipping, and receiving.

- a. These groups of personnel shall be trained and certified according to a basic subset of materials defined by the NASA LaRC ESD POC prior to any handling of ESDS packaged items.
- b. Here the ESDS item(s) are marked by one of the symbols shown in Figures 5-1 or 5-2, and are protected by the packaging they are in.

3.3.9 Janitorial personnel who are responsible for cleaning in certified EPAs shall be trained and certified according to a basic subset of materials defined by the NASA LaRC ESD POC prior to working in any such area marked as an EPA.

3.3.10 The ESD Program Monitor shall ensure that EPAs provide protection to sensitive items not only through the use of approved and verified equipment, furniture, fixtures, tools and materials, but also by limiting access only to trained and certified personnel.

- a. A list of certified personnel shall be clearly posted at the entrance to an EPA.
- b. Certification audits of EPAs shall include confirmation of the certification status of the personnel operating therein.
- c. Training shall be performed on a biennial basis.
- d. The certifying authority is responsible for ensuring that certified individuals will correctly implement this NASA LaRC ESD CPP. The evidence of ESD Safety certification, which is requested during an EPA audit, shall be provided by the ESD POC.

April 13, 2011

LPR 8739.21

3.3.11 The training organization shall provide evidence of completion of training to the trained individual (and may call this evidence “certification of training”); however, a completion of training card or completion of training certificate for an “Operator” is not a substitute for final certification.

### **3.4 TRAINING PROGRAM**

3.4.1 The initial classroom instruction will be 4 hours in duration for:

- a. Instruction.
- b. Design.
- c. Operator: handling, installation, maintenance and repair.
- d. Inspection and test.

3.4.2 The initial classroom instruction will be 2 hours in duration for:

- a. Procurement (only if handling or specifying ESDS materials), storage, shipping and receiving.
- b. Janitorial (only if responsible for cleaning in EPAs).

3.4.3 The SMAO shall obtain and control a database of trained individuals.

3.4.4 The training shall include the following, as a minimum:

- a. ESD Control Program policies, procedures and practices.
- b. Principles of static electricity and methods of ESD control.
- c. Identification of ESDS items.
- d. Protective materials and equipment.
- e. Protected areas and workstations.
- f. Handling of ESDS items.
- g. Packaging, marking and shipping of ESDS items.
- h. Performance of ESD audits.
- i. Administration and record keeping.
- j. Class preparation, presentation and test administration.
- k. Demonstration of ability to teach a class.

3.4.5 The NASA LaRC training program shall instruct students how to fully implement the NASA LaRC ESD CPP.

- a. Outside ESD training does not replace formal NASA training and such training is not recognized under this LPR.

3.4.6 Civil servant personnel or personnel performing work in a NASA LaRC facility should contact the NASA LaRC ESD POC for information regarding the ESD Control implementation plan and availability of the required training.

April 13, 2011

LPR 8739.21

**3.5 CERTIFICATION OF TRAINING LEVELS**

3.5.1 A three-level training program shall be used to address training needs:

- a. There will be one Level A or Master Instructor and that person shall be the NASA LaRC ESD POC, who will train Level B instructors (and may assist Level B instructors' with their training duties);

(1) Instructor Level A: Level A instructors have the authority to train Level B instructors, Designers, Operators, Inspectors, Testers, Procurement/Storage/Shipping/Receiving, and Janitorial.

- b. There shall be one main and one backup Level B Instructor, who will train Designers, Operators, Inspectors, Testers, Procurement/Storage/Shipping/Receiving, and Janitorial;

(1) Instructor Level B: Level B instructors have the authority to train Designers, Operators, Inspectors, Testers, Procurement/Storage/Shipping/Receiving, and Janitorial.

- c. There shall be at least one Program Monitor per branch in each directorate where EPA's have been established, who will verify and then certify Operators who have proven their competency to perform work.

(1) ESD Program Monitor: This training is for those who are directly responsible for compliance of EPAs to the ESD CPP.

(2) ESD Program Monitor training is with particular emphasis and detail provided on:

- (a.) Grounding and charge retention verification methods.
- (b.) Sources of electrical charge.
- (c.) EPA design.
- (d.) Compliant equipment, furniture, fixtures, tools and materials.
- (e.) Monitoring responsibilities and associated record-keeping.
- (f.) EPA certification process.

- d. The project's Mission Assurance Engineer (MAE) shall receive training for the Program Monitor.

**3.6 TRAINING RECORD MAINTENANCE**

3.6.1 NPR 1441,1 records retention requirements apply to training records.

3.6.2 Training records shall be retained for at least two years.

3.6.3 Federal Acquisition Regulations and/or other Project-level requirements may specify longer retention periods.

3.6.4 Training records shall include the following information:

- a. The applicable standard (ANSI/ESD S20.20) and the NASA LaRC ESD CPP LPR-8739.21.

April 13, 2011

LPR 8739.21

- b. Name of the trainee.
- c. Name of the organization which employs the trainee.
- d. Level of training completed.
- e. Date of completion of training.
- f. Name of the instructor and organization providing the training.
- g. Traceability number of the completion record or training certificate.
- h. Test score.

3.6.5 Successful completion of training shall be provided to students for submission to the personnel certifying authority.

- a. LF 120 shall be used as the Certification of Training.

### **3.7 MAINTENANCE OF TRAINING AND CERTIFICATION**

3.7.1 Level B instructors, ESD Program Monitors, Designers, Operators, Inspectors, Testers, Procurement/Storage/Shipping/Receiving, and Janitorial personnel shall undergo periodic retraining and recertification under the following conditions:

- a. New ESD control techniques have been approved that require different skills.
- b. Two years have elapsed since last certification, as per section 3.3.11.c.
- c. Job performance indicates inadequate understanding of ESD controls.
- d. Evidence of successful completion of training (to the applicable standards, see 3.6.4.a) is not available to the certifying authority.



April 13, 2011

LPR 8739.21

## 4 ESD CONTROL REQUIREMENTS FOR FACILITIES

### 4.1 GENERAL

4.1.1 This section pertains to EPAs, including facilities, equipment, tools and materials.

- a. The instructions and recommendations in this section include specific facility inspection methods used by ESD Program Monitors and the ESD POC in periodic verifications and certification audits.

4.1.2 The default EPA certification level shall be HBM Class 1A. HBM Class 0 applies when handling parts sensitive to lower than 250 volts.

4.1.3 Additional protective measures shall be used when protecting items to which the protection level is HBM Class 0 and sensitivities are at or below 100 volts. Where an ESD protection level applies that is more restrictive than HBM Class 1A (i.e., protects more highly sensitive items), signage shall be used to clearly mark and communicate to personnel the boundaries and class level of the EPA.

4.1.4 The measurements of Table 4-1 shall be performed as follows:

- a. Operators at the EPA perform tests numbers 5, 7, 8 (continuous), 11, and 13 as they apply to their area. The Operator shall use LF 22 Test Log to record test results.
- b. The area ESD Program Monitor is responsible for verification of tests numbers 1, 2, 3, 4, 6, 8(annual), 9, 10, 11, and 12. The Monitor shall use LF 23 ESD Protected Area Test Log.
- c. The ESD Program Monitor for the area shall ensure that the logs are up to date.

### 4.2 COMPLIANCE

4.2.1 The ESD Program Monitor shall identify non-conformances and:

- a. Implement corrective actions.
- b. Ensure that “unusable” areas and equipment are not used with ESDS items.

4.2.2 A work bench or work area cannot be certified or treated as active until all non-conformances relative to Table 4-1 are corrected.

- a. This may involve repair or replacement of equipment and marking the equipment and/or space “unusable” in the interim.

4.2.3 ESD Program Monitors shall use a corrective action system to identify and track all non-conformances to ensure that all findings are addressed before the work area is used again for handling or processing ESDS items.

### 4.3 TRACEABILITY

4.3.1 ESD Program Monitor verification records, especially those related to Table 4-1 shall be kept in the proximity of the associated EPA.

4.3.2 These records shall be passed between program monitors if benches or spaces transfer between departments or projects.

April 13, 2011

LPR 8739.21

4.3.3 The record retention period shall be a five (5) year minimum, as defined in Table 1-1 Record Retention.

#### **4.4 IDENTIFICATION AND ACCESS - ESD AREAS**

4.4.1 The ESD Program Monitor shall use prominently placed signs and a partition, rope guards, or similar barriers for clear demarcation of the presence and boundaries of EPAs where ESDS items are to be processed..

4.4.2 The boundary defining method is intended to prevent unauthorized and untrained personnel from entering the EPA.

4.4.3 Personnel who are not ESD-certified that must enter the EPA shall be accompanied by an ESD-certified escort (e.g., visitors or maintenance personnel).

April 13, 2011

LPR 8739.21

**Table 4-1: ESD Control Program Verification Schedule and Measurements**

Test #	ITEM	Para. Ref.	Test Parameters	Verification Intervals				
				Continuous	Daily	Weekly	4	
							Monthly	Annual
1	<sup>2</sup> Work Surface Resistance	4.7.6	$< 10^9 \Omega$ Between two points 10" apart on the Work Surface and 2" from the edge in the commonly used area.				X	
2	Work Surface Grounding	4.7.7	$10^6$ to $10^9 \Omega$ from the center of the work surface to the equipment ground or $< 1$ ohm if a GFCI is used.				X	
3	<sup>1,2</sup> Protective Floor Resistance	4.8.3	$< 10^9 \Omega$ . After cleaning the floor shall be checked and the data recorded. See restrictions on paragraph 4.8.2 (This is a Class 0 requirement)				X	
4	<sup>1,2</sup> Protective Floor Grounding	4.8.2	$10^6$ to $10^9 \Omega$ from the floor surface to the equipment ground or $< 1$ ohm if a GFCI is used. (This is a Class 0 requirement)				X	
5	<sup>3</sup> Wrist Strap Check	4.9.2a 4.10.4	Use approved Wrist Strap checker and log daily. The use of CMS is preferred.		X			
6	Wrist Strap Ground Point Resistance	4.9.2.a.d	$< 1$ ohm impedance from Groundable Point (Gp) to the Equipment Ground. ( $< 1.2 \times 10^6$ ohms if measured through a CMS).				X	
7	<sup>3</sup> Foot Grounding Device Integrity	4.9.3b 4.10.3	$< 3.5 \times 10^7 \Omega$ or use approved (calibrated) footwear checker & log each time personnel enters the EPA area.		X			
8	<sup>2</sup> ESD CMS	4.10.4	Verify functionality before handling ESDS items. Check alarm limits per Mfr. Instructions yearly.	X				X
9	<sup>2</sup> Stool / Chair Grounding.	4.11.6.2b	$< 10^9$ ohms to the chair's groundable point. [For Class 0 Work only, verify monthly].				[X]	X
10	<sup>2</sup> Carts	0	$< 1$ ohm if tied directly to equipment ground. $< 10^9$ when grounded thru conductive flooring, referenced to CPG.					X
11	Relative Humidity (RH)	4.11.8.1	30 to 70% RH at room temperature continuous for work area. For Class 0 Work Area certification RH should be $> 40\%$ .	X				
12	<sup>2</sup> Ionizers	4.11.9.1a	See Table 4-2 for test parameters.				X	
13	Soldering Iron Tip to Ground Resistance	4.12.5.c	Soldering Stations with self-contained checkers shall use them per schedule. Otherwise check to $< 20$ . Ohms and $< 2.0$ mVAC.			X		

<sup>1</sup> Additionally, the Protective Floors resistance are checked and documented at least 2 hours after the floor has been cleaned but before the room is used. The area does not need to be checked after vacuuming.

<sup>2</sup> These items require proof of verification. (i.e. sticker or log entry)

<sup>3</sup> Automatic data loggers may be used for wrist strap and foot grounding daily checks.

<sup>4</sup> For workstations with sensitivities of HBM Class 1A ONLY, this interval may be done quarterly as a minimum.

## 4.5 TEMPORARY USE OF ESD BENCHES FOR NON-ESDS WORK

4.5.1 The ESD Program Monitor shall ensure that non-ESDS work performed at EPAs does not cause ESD CPP non-conformances or lead to damage to ESDS items. The following requirements apply:

April 13, 2011

LPR 8739.21

- a. Permission from the cognizant ESD Program Monitor is obtained before work is started.
- b. The ESD Program Monitor clearly marks the affected area as a “Non-ESD Protected Area” with a LF 385 during the period it is used for non-ESDS work.
- c. The ESD Program Monitor verifies the EPA before ESDS items are again handled in that area.

4.5.2 ESD workstations designated as Class 0 or higher sensitivity shall not be used for Non-ESDS work.

- a. If any of these areas are used for non-allowed material handling, recertification by the ESD POC shall be necessary.

#### 4.6 PROHIBITED MATERIALS AND ACTIVITIES

4.6.1 The following housekeeping practices are critical for continuous EPA compliance and shall be adhered to:

- a. Smoking, eating and drinking in EPAs is not allowed.
- b. Materials unessential to the work being done in the EPA are not allowed.
- c. Other than materials specifically made and verified to be safe in an EPA such as but not limited to clipboards, books, notebooks and loose sheets of paper used to read or record data or follow instructions (this manual included), are kept at least 1 meter (3.3 ft.) from ESDS items or placed in ESD-safe bags or totes.
- d. Floors or mats are kept free of dust, dirt and other contaminants.

4.6.2 A 1-meter minimum separation shall be maintained between the location where ESDS items are handled and ESD Protective mats, or “tacky mats,” are used at the entrance to Clean rooms, cathode ray tube (CRT) displays, and other equipment, including equipment that generates a static charge.

4.6.3 The risk of damaging an item by an ESD event is heightened when the item is left exposed and/or unattended at a workstation or elsewhere.

- a. ESDS items shall be placed on an ESD protective surface and wrapped or covered with static shielding material when they are left unattended for short periods of time, such as a lunch break.

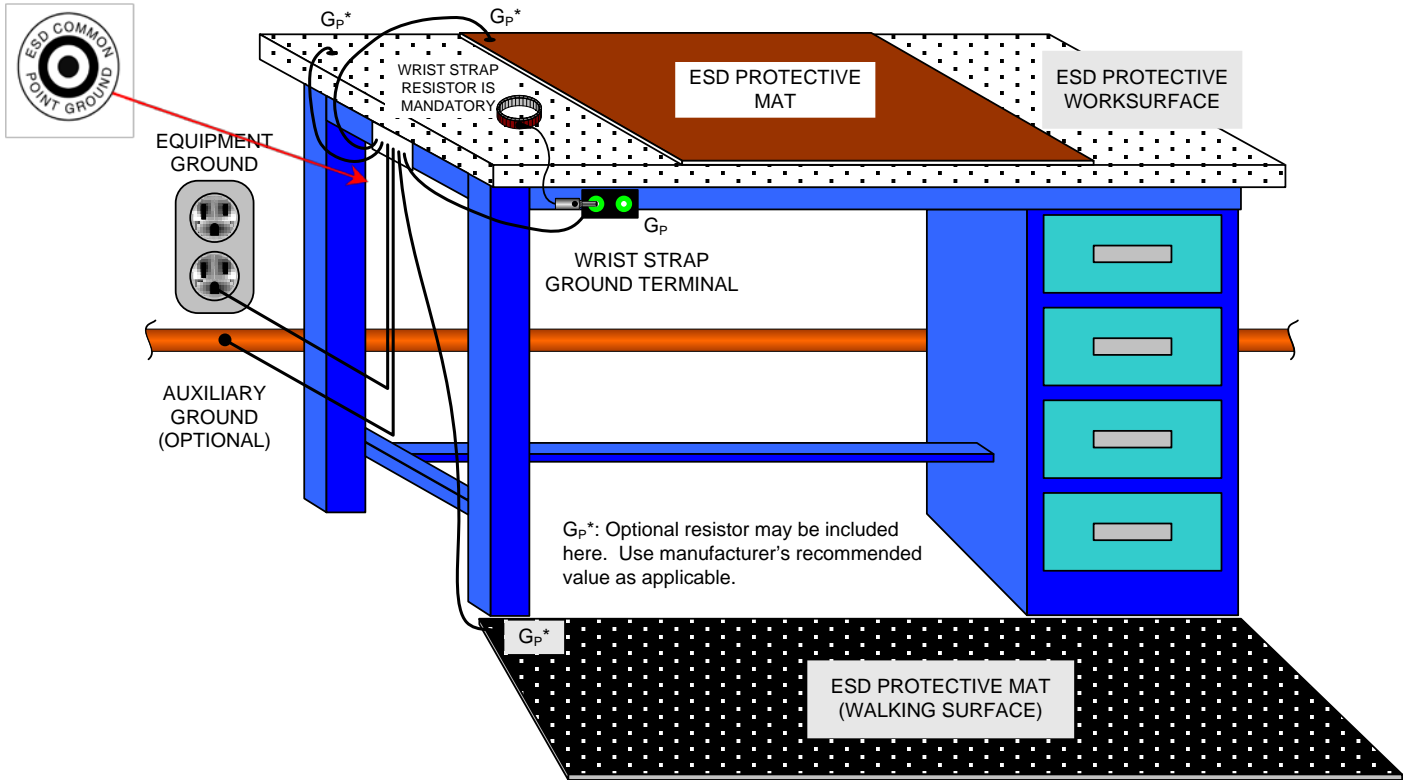
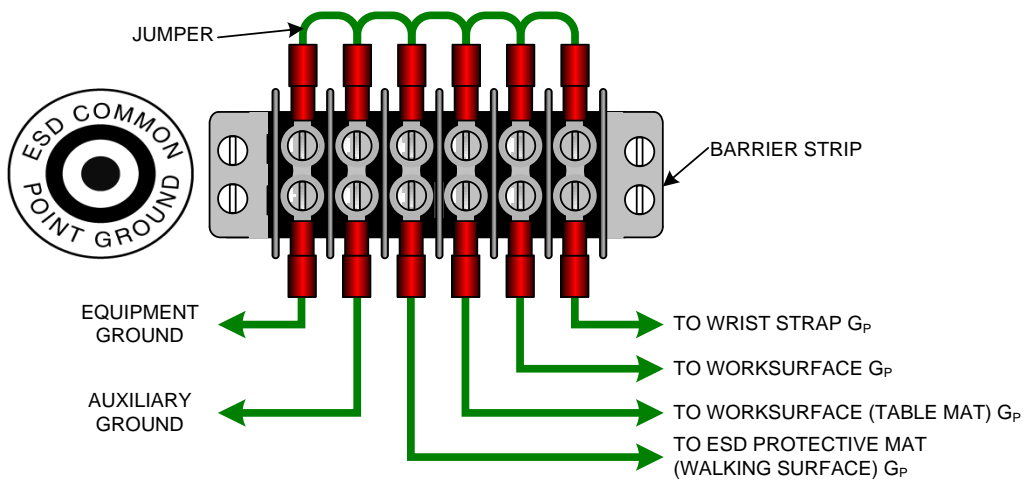

Figure 4-1: Typical ESD Grounded Workstations



EXAMPLE – COMMON POINT GROUND

(G<sub>p</sub>) = GROUNDBLE POINT

Figure 4-2: Workstation Common Point Ground

April 13, 2011

LPR 8739.21

**4.7 ESD-PROTECTIVE WORK SURFACES**

4.7.1 The default conductivity level for all work surfaces in an EPA shall be static dissipative ( $>10^5$  to  $<10^9 \Omega$  for surface resistance). Some work in EPAs requires conductive surfaces ( $<10^5 \Omega$ ) (e.g., optical benches).

4.7.2 ESD-safe surfaces shall be electrically connected to the Common Point Ground.

- a. The common point ground may be a terminal strip, bus bar, or any other convenient configuration and shall be, within itself, electrically continuous to no greater than 1 ohm measured from point to point with an ohmmeter.

4.7.3 Conductive work surfaces (such as stainless steel, copper) shall be connected directly to AC equipment or auxiliary ground. See ESD TR20.20-2008 section 5.1.3.

4.7.4 GFCI shall be used with conductive work surfaces.

**4.7.5 Extreme care is required when using conductive work surfaces.**

- a. To eliminate the safety hazard associated with a high current event that results from touching a high voltage circuit with one hand and a hard ground with the other hand, work surfaces shall be either soft grounded by installing a resistor in series with the ground ( $> 800 \text{ k}\Omega$ ), or protected by a GFCI must be used (GFCI, disconnects the circuit when an unsafe current event is detected, usually  $\approx 5 \text{ ma}$ ). The use of the  $1 \text{ M}\Omega$  ( $1 \text{ M}\Omega \pm 20\%$ ) optional resistors in Figure 4-1 is acceptable in lieu of the GFCI.
- b. Conductive work surfaces also generate a CDM hazard for very sensitive devices.

4.7.6 The protective work surface shall be selected such that:

- a. It does not release particle contaminants.
- b. It will resist attack by common solvents or cleaners (see Section 4.15.1).
- c. It is sufficiently large to accommodate the resting of common hand tools on the protective surface rather than on adjacent non-protected surfaces.

4.7.7 Soft grounding of dissipative work surfaces shall measure  $< 10^9$  ohms.

- a. When highly conductive work surfaces (e.g., stainless steel or copper) are used, and they need to be connected directly to the equipment or auxiliary ground without the optional resistor (see Figure 4-1), GFCIs shall be used in the ESD-protected workstation.
- b. Type "A" GFCIs are preferred.
- c. GFCIs shall be tested at least once a month using their self-test feature (see Appendix C, paragraph C.5.2.2.2). The GFCI manufacturer's Web site usually has a preferred/recommended method to check their particular model.

April 13, 2011

LPR 8739.21

## 4.8 ESD-PROTECTIVE FLOOR SURFACES

4.8.1 Conductive or dissipative floors and/or grounded conductive/dissipative floor mats shall be used in EPAs where personnel are not wearing wrist straps.

- a. To provide the intended ESD protection under these conditions, the use of leg straps, heel straps or conductive shoes shall be used (see 4.9.3).
- b. Conductive/dissipative flooring combined with ESD chairs are strongly recommended in HBM Class 0 EPAs to provide equipotential ground.

4.8.2 ESD protective flooring is not effective if it is not grounded.

- a. ESD protective flooring may be connected directly to equipment or an auxiliary ground without the optional resistor (see Figure 4-1).
- b. For testing purposes, the dissipative floor-to-system ground resistance target shall be  $< 10^9$  ohms.
- c. ESD TR20.20-2008 recommends  $10^6$  to  $10^9$  ohms for floor resistance for safety reasons.
- d. On highly conductive floors either the resistor (see Fig 4-1) or GFCI shall be used.
- e. Measure the floor resistance between the equipment ground and a point on the floor at least 12 inches away from the floor-to-ground connection.

4.8.3 After each cleaning, the ESD Program Monitor shall verify floor resistance per section 4.8.2 above and the results recorded in LF 23 EPA Test Log. Vacuuming or dry sweeping the floor does not require a subsequent check.

- a. Conductive waxes shall be used in compliance with manufacturer recommendations.
- b. The ESD Program Monitor shall verify the floor resistance after application and that the results have been recorded in LF 23 EPA Test Log.
- c. The conductive wax used in an EPA shall be approved by the ESD POC.

*NOTE: Some conductive waxes may be a source of contaminating volatiles. Make sure the type used has been approved for use around flight hardware.*

- d. A conductive wax on non-conductive floors is not considered an effective method of ESD control.
- e. At this time, no carpeting, including products advertised as "conductive" or "static-eliminating," is considered suitable for use in an EPA.

## 4.9 PERSONAL GROUNDING DEVICES

4.9.1 All personnel working with or handling ESDS items shall be issued and required to use Personal Grounding Devices to prevent the accumulation of dangerous electrostatic charge levels.

April 13, 2011

LPR 8739.21

4.9.2 All personnel coming within 1 meter (3.3 feet) of any ESDS item shall be issued and required to use a personal grounding device.

- a. **Wrist Strap:** The wrist strap is the preferred means for ESD protection. It is the “first line of defense.” See 4.10.2 for recommendations on checking wrist straps. The wrist strap system consists of four major components:
  - (1) **Lead:** Only the lead supplied with the wrist strap should be used, as it may contain the safety resistor.
  - (2) **Cuff:** The design of the wrist strap cuff shall ensure conductive contact with the wearer’s skin. Metallic cuffs are preferred over plastic or fabric cuffs. Bead type chains are not effective and are normally prohibited.
  - (3) **Safety Resistor:** All wrist strap systems shall contain an integral current-limiting safety resistor (1 megohm  $\pm$  20%).
  - (4) **Ground Termination:** The wrist strap ground termination shall ensure a positive and durable connection between the lead and the Common Point Ground (CPG).
- b. The wrist strap shall have a cuff connector, which breaks away with a force between 1 and 5 pounds; as specified in ESD S1.1
- c. The resistance between CPG and the equipment ground, shall be <1.0 ohm.
- d. For wrist straps ground, protected through a CMS, the resistance to ground shall be <3.5x10<sup>7</sup> ohms to keep voltage on the body below the HBM of 100V

4.9.3 **Foot Grounding:** Foot grounding devices such as leg, toe or heel straps, or conductive shoes worn in conjunction with a conductive floor and/or conductive floor mats, are acceptable alternatives to a wrist strap in those situations where the Operator needs to be mobile and the use of a wrist strap is impractical or unsafe.

- a. When used, foot grounding devices shall be worn on both feet and are not to be worn outside the EPA.
- b. The total resistance to ground including the person, footwear and floor shall be < 3.5x10<sup>7</sup> ohms to keep voltage on the body below the HBM of 100V.
- c. When employing foot grounding devices, the ESD Program Monitor shall set up a footwear checker and LF 22 Check Log to monitor the continued performance of the personal grounding device system.

*NOTE: Foot grounding devices that are not kept clean will have reduced effectiveness from contaminants inhibiting their conductive interface with the floor.*

#### **4.10 INTEGRITY TESTING OF PERSONAL GROUNDING DEVICES**

4.10.1 The integrity of the connection between the Operator, the personal grounding device, and the ground connection is critical to proper ESD protection.

- a. The ESD Program Monitor shall schedule periodic verification of personal grounding device performance to identify non-compliant units.



April 13, 2011

LPR 8739.21

b. Typically, damaged or worn units are not repairable and must be replaced.

4.10.2 Wrist straps shall be either continuously monitored or checked each time the wearer enters the EPA using an approved wrist strap tester.

a. Operators shall use LF 22 Check Log to record the first daily test.

b. Logging wrist strap checks is not required for EPAs that use CMSs.

c. If a CMS is used at a workstation, all wrist strap connection points shall be enabled through the CMS.

d. Exceptions should be made for instances where the voltage-sensing from the CMS may damage very sensitive components.

4.10.3 Foot grounding devices shall be checked and logged each time the Operator enters the EPA.

a. If used, foot grounding devices shall be worn on both feet.

b. Foot grounding devices shall be checked one foot at a time.

4.10.4 The ESD Program Monitor shall check all Workstation Real Time Continuous Monitoring Devices to ensure functionality just before handling ESDS items. (The monitor's alarm should sound and the appropriate red light should light when the lead is temporarily removed from the cuff. Appendix C.5.2.6, Table 4-1 recommends a yearly verification of the trip limits.)

4.10.5 If one of the checks in 4.10.2 through 4.10.4 fails, corrective action shall be taken before work is performed and a subsequent re-check shall be conducted before work resumes. Appropriate corrective actions include:

a. Replace cord.

b. Replace complete system.

c. Use a conductive lotion designed for use with ESD wrist straps (if acceptable in the area of use).

d. Wrist band cleaning.

4.10.6 If it is found that an ESDS item was handled in an EPA with faulty ESD protection (e.g., wrist straps, grounding, and other ESD precautions), that item shall carry a risk lien that must be retired by the affected Project.

a. The failure of the ESD protection shall be recorded by the ESD Program Monitor in the associated project traveler.

b. The ESD Program Monitor shall inform the project's MAE of the ESD protection failure.

#### **4.11 EQUIPMENT AND FACILITIES**

4.11.1 Facilities Grounding: The preferred practice is to use the third wire AC line ground (equipment grounding conductor) for grounding all items at the EPA.

April 13, 2011

LPR 8739.21

4.11.2 When a separate grounding line is present or used in addition to the equipment ground, it should be electrically bonded to the equipment ground at each ESD protected work station to minimize the difference in potential as per ANSI/ESD S6.1.

4.11.3 The resistance of the conductor from the Common Point Ground to the equipment ground (AC ground) shall be less than 1 ohm.

4.11.4 The impedance from the area Common Point Ground to the neutral bond at the main service box shall be less than 2 ohms. See Figure 4-3.

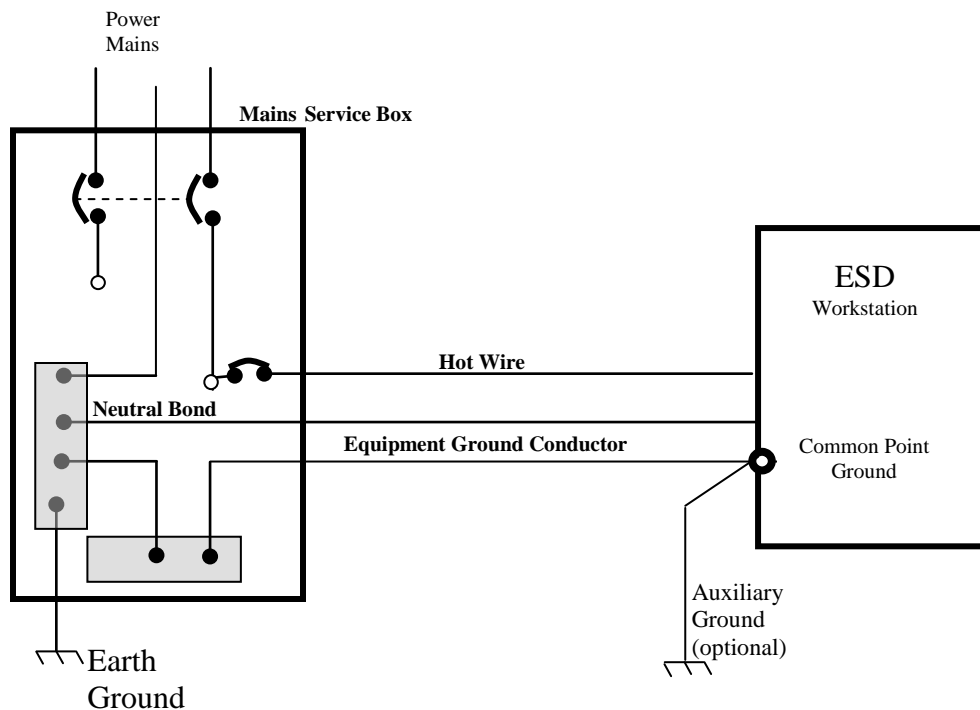

Figure 4-3: Main Service Box

4.11.5 Daisy chaining is not permitted.

4.11.6 Stools and Chairs and Carts.

4.11.6.1 The ESD Program Monitor is responsible for the certification and proper use of stools, chairs and carts in EPAs.

- a. Marking certified chairs, stools, and carts with identifying stickers shall facilitate their proper use and certification maintenance.
- b. Local ESD Safety procedures shall address EPA-specific uses of chairs, stools and carts relative to the employed grounding scheme.

4.11.6.2 Certification: The required verification levels and verification intervals for chairs and stools are shown in Table 4-1.

April 13, 2011

LPR 8739.21

- a. The resistance shown in Table 4-1 applies to measurements between any part of the chair and a groundable point.
- b. The resistance for any part of the chair to a groundable point shall be  $< 10^9$  ohms.

4.11.6.3 Grounding: For handling Class 0 sensitive items, there shall be a positive electrical contact between the Common Point Ground and the chair or stool.

- a. This contact may be achieved through an ESD protective floor or ESD protective floor mat.

#### 4.11.7 Mobile Equipment Carts

4.11.7.1 Where carts, wagons, trams, or other mobile equipment are used, they shall be grounded while in use in the EPA.

- a. When conductive floors are being utilized, there shall be a positive electrical contact between the floor and conductive structure of the mobile equipment.
- b. The required resistance used for verification from the equipment to the Common Point Ground is shown in Table 4-1.
- c. If the floor is non-conductive, the vehicle shall be grounded before ESDS items are loaded or removed from the vehicle.
- d. The use of protective packaging (ESD approved wrap material and totes,) shall be used when moving ESDS items for transport away from the EPA, even if a certified-safe cart is employed.

4.11.7.2 Other Mobile Equipment: When other tabletop equipment, such as microscopes or lead bending equipment, is used within an EPA, it shall be ESD grounded.

*NOTE: Such equipment may have a large capacitance and present a hazard to components susceptible to CDM type pulses. To avoid damage, the equipment and the component shall be at the same potential before they contact each other. This can be done by using dissipative materials to make first contact to both the component and the equipment.*

#### 4.11.8 Humidity

4.11.8.1 The relative humidity (RH) target range for EPAs at 20°C is 30% to 70% when monitored near the ESDS item (40% to 70% for Class 0).

- a. At levels below 30%, ESD risk increases, additional precautions shall be used such as turning on a humidifier to achieve the required humidity or using an air ionizer (See paragraph 4.11.9.1).
- b. If additional precautionary methods are not available (e.g., the use of an ionizer), work shall be halted and the RH recorded for traceability until the required humidity level is obtained (See paragraph 4.3 on records retention).

4.11.8.2 The ESD Program Monitor shall check the RH level in each EPA at the start of the workday and ensure that the result has been logged in the lab's LF 126 Laboratory Daily Humidity Log.

- a. Continuous compliance is verified with periodic observations and recording of the results. If the RH level is close to 30% or is seen to be dropping rapidly, extra vigilance is mandatory.

35

April 13, 2011

LPR 8739.21

b. Data loggers with an integral alarm system are suitable substitutes for the daily check.

4.11.8.3 Maximum RH depends on the equipment and device under test (DUT) to be protected as condensation due to temperature variations can cause corrosion, short circuits or moisture contamination.

4.11.8.4 Sealed ESD protective bags that have been stored in “dry boxes” with desiccant gel bags to prevent high humidity problems are easily charged.

a. Care shall be taken when removing ESDS items from ESD bags to prevent ESD events from triboelectric charging.

*NOTE: Surface resistivity changes exponentially with humidity changes.*

4.11.8.5 In EPAs with limited environmental control capabilities, projects may choose to use a Psychrometric Chart to monitor the Relative Humidity for real-time changes.

#### 4.11.9 Air Ionizers

4.11.9.1 Air ionization is a technique used to neutralize charges on insulators and ungrounded conductors.

a. Air Ionizers shall be used when handling Class 0 sensitive parts or when the RH falls below 30% in the work area, unless either of the conditions in section 4.11.9.d or 4.11.9.f exist. See Table 4-2.

4.11.9.2 Air ionizers are designed to work where unrestricted airflow exists between the ionizer and the ESDS item.

a. Air ionizer design also requires sufficient distance between the ionizer and the ESDS items to ensure proper ion balance in that airflow.

b. Operators shall consult the ionizer manufacturer’s documentation for detailed ionizer operating instructions.

4.11.9.3 The ionizer shall be carefully selected in order to realize its benefits in the EPA.

a. Ionizers shall undergo routine maintenance and testing in accordance with manufacturer’s recommendations to ensure acceptable continued performance.

4.11.9.4 The presence of ionized air creates an increased risk for corona discharge in the presence of “powered-up” high-voltage or radio frequency (RF) sensitive equipment, therefore, the use of ionizers is not recommended in those environments.

a. To avoid fire hazards from corona discharge, flammable materials shall be kept away from air ionizers.

4.11.9.5 Electrostatic survey meters in conjunction with a charging plate may be used to verify the effectiveness of ionizers in extremely sensitive work areas (e.g., Class 0, Class M1) before work is started.

a. It is important that the meter used has sufficient resolution and time response to detect values beyond the minimum performance limits required.

April 13, 2011

LPR 8739.21

- b. To avoid meter saturation or generating false data, the meter should be slowly moved into the area being measured while watching for readings close to the limits of the meter.

4.11.9.6 Though the use of ionizers is recommended for Class 0 EPAs, it is important that the ESD Program Monitor ensure that the ionizer is not the source of unacceptable charge deposition into the ESDS items.

- a. In these cases, the ESD Program Monitor shall ensure in advance that the ionizer peak balance potential is less than one half the susceptibility of the most sensitive part ( $\leq 50\%$  of item sensitivity level).

**CAUTION:** *An improperly adjusted air ionizer can actually charge ESDS devices and lead to possible damage to the device. Only calibrated air ionization systems shall be used.*

**Table 4-2: ESD Sensitivity for Selection and Performance of Air Ionizers**

Class	ESD Sensitivity	Air Ionization	Discharge time	Float Potential
1A +	$\geq 250$ volts	Optional	$\pm 1000$ to $< \pm 100$ V in $< 45$ sec.	$< \pm 100$ V
0 <sup>1</sup>	$> 100$ V to $< 250$ V	Required	$\pm 1000$ to $< \pm 50$ V in $< 20$ sec.	$< \pm 50$ V
0 <sup>2</sup>	$\leq 100$ V	Required	$\pm 1000$ to $< \pm 20$ V in $< 20$ sec.	See below 2
M1 <sup>3</sup>	$< 100$ volts	Required	$\pm 1000$ to $< \pm 20$ V in $< 20$ sec.	$< \pm 20$ V

<sup>1</sup> Class 0 covers all HBM  $< 250$  V but it is not sensitive enough to protect some newer parts.

<sup>2</sup> Class 0 with sensitivities at or below 100 V the ionizer peak balance potential shall be less than one half the susceptibility of the most sensitive part in the assembly.

<sup>3</sup> This level is intended for use with automatic equipment therefore it uses MM vs. HBM

## 4.12 HAND TOOLS, EQUIPMENT, AND FIXTURES

4.12.1 The ESD Program Monitor shall approve all tools used in the EPA.

4.12.2 Tools designed for ESD areas, such as static dissipative cushioned tools or un-insulated metal hand tools such as pliers, cutters, tweezers and wire strippers, not required in EPAs.

4.12.3 Hand tools should be kept on the grounded work surface when not in use.

4.12.4 Only antistatic solder extractors made of metal, or having a metalized plastic barrel and tip, shall be used in an EPA.

4.12.5 The following applies to electrical tools used in EPAs:

- They shall employ a three-wire grounded power cord.
- They shall have static dissipative handle grips.
- The tool's contact point (e.g., soldering iron tip) which touches the work piece shall have a resistance of less than 20 ohms ( $< 1 \Omega$  when new) and the potential difference does not exceed

April 13, 2011

LPR 8739.21

2 millivolts RMS using methods indicated in the supplier's process documentation. See Appendix C, section C.5.2.10 Test 10.

- d. Motor driven tools shall not be used near ESDS items due to inductive charging in the ESDS devices.

*Caution: GFCI systems can indicate a faulty soldering station but do not prevent damage to hardware from damaged soldering tips. Soldering stations are easily moved to the workbench; however, their records are not usually kept by lab monitors and the tips cannot be easily identified as verified ESD-safe.*

4.12.6 Digital Multimeters (DMMs) may introduce voltage spikes when changing scales and/or have high voltages when measuring resistance.

- a. The ESD Program Monitor shall ensure that the measuring equipment is compatible with the hardware being measured.

4.12.7 Fixtures used while working at an EPA shall be ESD safe and ground bonded to the Common Ground Point.

4.12.8 Measuring equipment, breakout boxes, harnesses, and similar equipment shall be properly discharged (grounded) before making connection to flight hardware.

- a. Consult with the hardware design engineer to ensure that test procedures clearly document hardware limitations and procedural considerations relative to the equipment normally used in the laboratory.

*NOTE: During testing of the Astro-E satellite, several J-FETs were damaged due to discharging of the DMM leads while touching a charged breakout box.*

#### **4.13 PROTECTIVE PACKAGING**

4.13.1 Electrostatic protective packaging shall prevent charge generation (e.g., triboelectric contact and separation) and protect from external electrostatic fields.

- a. Static dissipative materials used in packaging are considered to provide both properties.
- b. Static dissipative materials in intimate contact with devices shall have a surface resistance of  $\geq 10^4$  &  $< 10^{11}$  ohms.

4.13.2 Protective bags and packaging are considered ESD protective based on the following application methods:

- a. Materials used in protective bags and pouches shall possess like characteristics found in the Triboelectric series to satisfy the resistance requirements to avoid triboelectric charge buildup.
- b. Acceptable bags and pouches used for electrostatic shielding shall be constructed from a single folded piece of material.
- c. Two-piece construction is not considered ESD-safe.
- d. If bags or pouches are not transparent, allowing identification of contents without removal, the Operator shall label the bag by listing its contents on the outside of the bag or pouch.

April 13, 2011

LPR 8739.21

- e. Materials in contact with the protected hardware shall have a dissipative surface.
- f. Neither static dissipative impregnated nor topically treated plastics provide electrostatic shielding.
  - (1) The Operator shall enclose both types in an outer container which will provide shielding to the contents during shipping.
  - (2) For acceptable electric field shielding, the package shall be electrically conductive with a surface resistance of  $< 10^4$  ohms.

4.13.3 Compliant shipping packaging for all integrated circuits used by NASA shall be non-metallic conductive or static dissipative magazines, chutes and dip tubes.

- a. Integrated circuits that are shipped in non-compliant packaging shall not be used in flight hardware.

4.13.4 ESD-safe tote boxes shall be made of conductive or static dissipative material.

- a. Compliant tote boxes shall be fitted with covers of the same conductivity as the bottom sections that fit tightly enough to ensure conductivity across this interface.

#### **4.14 TEMPERATURE CHAMBERS AND COOLING AGENTS**

4.14.1 ESD Program Monitors shall take appropriate precautions such as air ionization, to neutralize the static charge on insulated and isolated objects when gas flow is utilized in the area of ESDS items.

- a. Particles in the gas flow can be a significant generator of electrostatic charges.

4.14.2 To ensure the safety of ESDS items in cold chambers, conductive baffles and shelves within the chamber shall be grounded.

- a. ESDS items contained within those chambers shall have a path to ground by mounting them or placing them on conductive material (preferably a dissipative surface) that is in contact with the grounded shelves.

4.14.3 ESD Program Monitors shall take appropriate ESD precautions when pressurized cryogenic cooling agents are used for localized cooling, such as in troubleshooting. "Mist Freeze" has proven to be a very good ESD generator.

4.14.4 The stability of ESD-protective materials that are used in temperature chambers shall be rated for the test temperature and humidity ranges present in those chambers to ensure the test and measurements are properly achieved, to prevent damage to the equipment, and to prevent contamination of the chamber.

4.14.5 Resistance checks shall be a minimum requirement for normal test chamber environments.

- a. For extremely sensitive parts, the use of electrostatic survey meters shall be used (see section 4.16.2).
- b. Survey meters can provide information on stray fields harmful to the hardware being tested.
- c. The ESD Program Monitor shall consult the meter manufacturer's documentation for additional cautions.

April 13, 2011

LPR 8739.21

#### **4.15 CLEANING AND CLEANING AGENTS**

4.15.1 Cleaning personnel who have been ESD trained shall ensure that the cleaning agents and methods used on ESD-protective items (e.g., work surfaces and floor coverings) have been selected and applied so that they do not reduce the effectiveness of these items, cause leaching, or leave insulating residues.

4.15.2 In addition to other required properties (e.g., solvency), the ESD POC shall approve of cleaning agents used directly on ESDS items that have been selected for low electrostatic charging propensity and approved for use in flight hardware.

4.15.3 Only natural bristle or static dissipative brush materials shall be used on ESDS items.

#### **4.16 ELECTROSTATIC SURVEY METERS, VOLTMETERS, AND MONITORS**

4.16.1 Electrostatic survey meters are used to detect the presence of electrostatic charges.

- a. Only those types of electrostatic survey meters that read the electrostatic charge on a surface area without requiring contact shall be used in NASA EPAs.
- b. These instruments shall be capable of measuring the voltage on a sample not more than 8 inches in diameter with a minimum resolution of 100 volts and a range of at least 1 kilovolt (kV).
- c. For areas handling highly sensitive parts, other methods may be needed.
- d. Always follow the manufacturer's recommendations.

4.16.2 Use of electrostatic monitors designed to actuate an alarm when an electrostatic field reaches a preset level shall be used in an EPA handling ultra sensitive hardware.

- a. It should be noted that these monitors are very sensitive and require a lot of trial and error to properly position them to avoid false alarms.

4.16.3 Wrist strap testers and recording logs shall be made available in all areas where ESDS items are handled, unless the ESD protective area exclusively uses a CMS.

#### **4.17 CLOTHING REQUIREMENTS**

4.17.1 Static dissipative outer garments (smocks) shall be worn at all times when in EPAs.

- a. A compliant smock shall cover all personal garments above the wrist except at the neck area and make intimate contact with the skin.
- b. Smocks shall be fully zipped/buttoned at all times they are worn.

4.17.2 The ESD Program Monitor shall properly check all garments after laundering.

- a. This requirement may be met by using an approved cleaning facility for ESD garments that provides this service.

4.17.3 When handling ESD Class 0 sensitive parts, the ESD smock shall be connected to the common point ground or wrist strap lead. Otherwise, it becomes an isolated ungrounded conductor.

- a. Some garments have the provision for attachment to the wrist strap coil cord snap.



April 13, 2011

LPR 8739.21

b. Some configurations also allow for continuous monitoring.

4.17.4 When cuff-to-cuff resistance of the garment is  $< 3.5 \times 10^7 \Omega$ , the garment can be grounded using a single wire wrist strap cord.

a. This arrangement, when used with the corresponding continuous monitor device, meets the requirements of section 4.9 and can be used in lieu of the wrist strap or foot grounding systems.

b. This setup does not work with the dual wire CMS.

4.17.5 For less sensitive areas (Class 1A and above), smocks may be used over cotton shirts or short-sleeved shirts without the extra ground connection.

a. This configuration permits slow static dissipation of the charge acquired by the garment (wrist straps shall be worn).

4.17.6 Finger cots and gloves, when worn in an EPA, shall be made of static dissipative materials.

#### **4.18 ORBIT REPLACEABLE UNITS (ORU) REQUIREMENTS**

4.18.1 An electronic assembly manufactured with a conductive outer enclosure is expected to be ESD sensitive only through exposed connector pins.

a. If conductive or static dissipative caps cover the connectors, the box forms a Faraday cage around the internal ESDS components.

b. A charge on the box should not cause damage to the internal components as long as the Faraday cage is intact and the charge is removed prior to mating any connectors.

c. All ORUs installed in their normal flight configuration, with all connectors mated and/or covered, whether in a launch vehicle or in a test configuration simulating flight conditions, are not considered ESDS unless analysis or testing has shown otherwise.

4.18.2 ESD precautions shall be implemented prior to the connector or connector caps being removed.

a. Exposed connector pins shall be touched or tested only after the Operator and the box are at the same ground potential (equipotentially bonded ground).

4.18.3 Interconnecting Cables: Tests conducted on cables have shown that a charge of several hundred volts can be generated on the conductor of a cable as the cable is flexed, unwrapped, and handled in a similar manner as would occur during cable installation in a vehicle.

a. This charge, which is generated by the triboelectric effects of the wire and its insulation, can potentially damage sensitive devices that would ultimately be connected to the cable.

b. Prior to the initial mating of newly installed cables, the connector pins and cable shield shall be grounded to discharge any electrostatic potential.

c. An existing cable that is connected to another ORU does not require shorting prior to mating.

d. When installing test equipment to flight hardware, the cables shall be installed to the non-flight equipment prior to the flight equipment.

April 13, 2011

LPR 8739.21

4.18.4 Operator Grounding During ORU Installation: As noted in the previous paragraph, an ORU with protective connector caps is not considered ESDS, but it is highly recommended that personnel be grounded throughout the installation or removal process.

- a. The use of a wrist strap in a spacecraft shall be regulated by the need to protect metal surfaces from scratches caused by alligator clips on soft metals and the need to preclude conductive debris generated by the teeth of the clips.
- b. In addition, the working space may be too constrained to wear a wrist strap. In these cases, the Operator shall use some other means to equipotentially bond (ground) themselves with the ORU and connector prior to mating and de-mating.

4.18.5 Procedures for ESD-safe handling of ORUs shall include the following practices:

- a. Upon arrival at the equipment rack with the ORU, the mobile cart shall be tied to ground.

*NOTE: If the ORU cannot be grounded through connection to the grounded cart, it is acceptable to momentarily ground the ORU by touching it with one hand and touching a grounded conductive surface with the other hand.*

- b. Conductive or dissipative covers shall be installed securely in place.
- c. Prior to moving the ORU from the cart, all personnel shall momentarily ground themselves by touching a grounded object.
- d. The ORU may be moved to the equipment rack without the use of a grounded wrist strap, however, a wrist strap or other grounding method shall be used by the technician/Operator prior to removing any connector covers.
- e. The procedure for removing an ORU from the equipment rack is the reverse of items a-d above. A grounded wrist strap shall be worn prior to removing a connector from the rack and reinstalling the connector cover.
- f. When removing a connector from a non-ESDS ORU that is directly wired to a known ESDS ORU, the technician shall comply with the requirements of section 4.18 of this manual.
- g. When a patch-panel/breakout box has been installed into the wiring harness of an ESDS ORU, all operations performed using the breakout box require the Operator to be grounded and a sign shall be placed at the worksite warning of the ESD damage concern.

4.18.6 Determination of an ORU's ESD Sensitivity: For all new flight hardware designs, it is the responsibility of the hardware design activity to determine if an assembly is ESDS.

- a. The hardware shall be properly marked and documented as to the HBM sensitivity Class (e.g. 0, 1A, and 1B) or non-ESDS and the proper procedures for handling and packing shall be provided.
- b. All ORUs with an unknown ESD sensitivity shall be handled as HBM Class 1A.

*NOTE: The requirements above imply ESD susceptibilities of above 1 kV and below (HBM 1C).*

April 13, 2011

LPR 8739.21

4.18.7 Hardware handled by the crew during flight should not be ESDS.

- a. It is highly recommended that even for a flight item known to be ESD immune, these items are transported in ESDS packaging.
- b. Static generating materials are a hazard if they come in close proximity to ESDS hardware.

April 13, 2011

LPR 8739.21

## 5 ESDS ITEM HANDLING

### 5.1 GENERAL

5.1.1 ESDS items shall be handled only in EPAs.

- a. When outside of EPAs, ESDS items shall be completely enclosed inside ESD-protective packaging in a ESD protective container (tote or box).

5.1.2 Paperwork accompanying an ESDS item (e.g., QA records, routings, and instructions) shall be contained in static dissipative bags or envelopes.

- a. This paperwork shall never come in physical contact with an ESDS item.
- b. Materials specifically made and verified to be safe in an EPA are exempt from this requirement.

5.1.3 Shunts, such as bars, clips, or conductive coverings, shall be used to protect an ESDS item when it is not being tested or worked on.

- a. An ESD event may occur if extreme care is not exercised to ensure that both items are at the same potential when attaching any conductive material to an ESDS device.
- b. Process-essential insulators (e.g., Kapton<sup>®</sup> tape) shall be neutralized with an ionizer before they are moved within 12 inches of ESDS items.

5.1.4 All containers, tools, test equipment, and fixtures used in EPAs shall be grounded before and during use.

- a. Before connecting or disconnecting test cables, a common soft ground between an ESDS item and any test equipment shall be established.

5.1.5 While in the vicinity of ESDS items, personnel handling ESDS items shall avoid physical activities that produce static charges (e.g., wiping feet, or adding or removing items of clothing).

### 5.2 SPECIAL REQUIREMENTS FOR HIGHLY SENSITIVE ITEMS

5.2.1 Table 5-1 summarizes the requirements made throughout this document that is particular to HBM Class 0 and MM Class M1 only.

- a. For higher sensitivity levels, for devices sensitive to CDM events, or for other special cases, the Project engineers shall partner with the ESD POC to determine suitable ESD CPP requirements.

5.2.2 When assembling parts sensitive to low voltage and low energy pulses, the measures prescribed for HBM and MM models do not provide sufficient component protection.

- a. This section provides guidance for handling components sensitive to breakdown voltages as low as 2 volts and energies as low as 0.3  $\mu$ J.
- b. Electromagnetic interference (EMI) signals can inductively charge components with these low level sensitivities and put them at risk from an ESD event that is so rapid it evades HBM and MM safety methods.

April 13, 2011

LPR 8739.21

- c. Parts in this category include detectors, some high-frequency low-voltage differential signal (LVDS) transceivers, low noise amplifiers (LNAs), Noise diodes, and integrated circuit (IC) RF switches.

### 5.2.3 Equipment

5.2.3.1 All ports in the flight hardware shall use shorting plugs/ESD caps when not in use, including when inside their ESD bags.

- a. RF ports shall use a metal dust cap to form a faraday cage.

5.2.3.2 Operators should use ESD finger cots instead of ESD gloves.

**Table 5-1: Summary of Requirements Applicable to HBM Class 0 and MM Class M1**

Topic	Recommendation
Chairs & stools	Ground and periodically verify as ESD protective. See Table 4-1 for intervals
Conductive or dissipative floors or floor mats	Use them in the area in front of the protected area or in the designated EPA floor space
RH	Kept over 40%, monitor and record just before work is started. Additional precautions must be used to operate below 40% RH.
Ionizers	Keep them in place and working properly. See Table 4-2. It is recommended that an ESD survey meter be used to check the area before work is begun.
Smocks	Must be grounded to the Common Point Ground or through the wrist strap. However, the CMS, if used, must not interfere with grounding of the smock or vice versa.
Mating and De-mating cables and harnesses	Must be discharged to ground through an approved method prior to mating and de-mating to ESD sensitive assemblies
Soldering irons	Check for proper ESD operation before start of operation.
Signage	Display them, describing the Class sensitivity level for the area

5.2.3.3 The DUT shall be placed on metal that in turn is placed on a certified ESD workbench.

5.2.3.4 This plate shall be permanently grounded to the power supply in the test setup using a separate ground braid and connected in the same fashion as the chassis connection called out in the test procedure setup.

*Caution: This step may compromise components with low voltage CDM sensitivity. For CDM protection below 100V, one should avoid metal-to-metal contact.*

5.2.3.5 ESD garments shall have conductive elastic cuffs or have means by which they can be grounded.

5.2.3.6 Avoid highly triboelectric materials under the ESD garment (e.g., silk, wool). Cotton or cotton blends are recommended.

5.2.3.7 Continue to use wrist straps per the current requirements.

April 13, 2011

LPR 8739.21

5.2.3.8 If a CMS is used, the sensing voltage of the system shall be lower than the most sensitive component to be handled.

- a. If CMS cannot be used, the Operator/garment combination shall be checked and recorded at least once a day.
- b. The Operator shall check himself every time he/she enters the area.

5.2.3.9 A voltmeter check of all powered equipment grounding (including soldering irons, power supplies, spectrum analyzers, and similar equipment) shall be performed before removing the shorting plugs and making contact with the DUT.

5.2.3.10 Cleaning procedures around sensitive parts should be performed using ethyl or isopropyl alcohol and a small horsehair brush (not cotton swabs).

- a. Hot air guns shall not be used.

#### 5.2.4 Handling and Operational Procedures

5.2.4.1 An ESD checklist shall be created as part of the production traveler, which includes a RH check (40-60%RH), possible EMI sources, static survey, and ionizer “sweet spot” as a minimum.

- a. This checklist shall be filled out before the start of each operation and when the physical configuration of the test area is changed.

5.2.4.2 Pagers, cell phones, or RF transmission devices shall not be powered ON in the room/area.

- a. Setting devices to “vibrate” does not eliminate the inductive charging risk from the EMI source originating from the wireless device.

5.2.4.3 The test setup shall be completed before the flight hardware is taken out of the ESD bag.

5.2.4.4 The ionizer shall be run during the operation

- a. Sensitive device(s) shall be within the “sweet spot” of the ionizer. It should be noted that some nearby electrostatic generators may change the “sweet spot” of the ionizer.

5.2.4.5 Test equipment with CRTs shall be turned on before the DUT is taken out of the ESD bag and kept as far as practical away from the DUT.

5.2.4.6 Once the setup is completed, the DUT shall be removed from the ESD bag, the grounds shall be equalized by touching with finger cots both the DUT and metal plate and then the DUT is to be placed on the metal plate.

5.2.4.7 Before power is applied to any RF device in the DUT, the ionizer shall be turned off.

5.2.4.8 Every tool shall be discharged by placing it on the ESD mat (or any dissipative surface).

- a. Test leads shall be discharged by touching the ESD mat with the lead for at least 1 second.
- b. This instruction applies to screwdrivers, tweezers, and special tools.

5.2.4.9 The proper ionizer discharge time and float potential shall be selected per Table 4-2.

April 13, 2011

LPR 8739.21

### 5.3 RECEIVING, INTERNAL HANDLING, AND SHIPPING

5.3.1 Incoming inspection shall include examining all ESDS items for proper ESDS precautionary marking and ESD-protective packaging.

- a. Inadequate precautionary markings shall be corrected and handling history investigated prior to further processing.

5.3.2 When an item is received that has not been protected during shipment or internal transfer, it shall be:

- a. Rejected as defective.
- b. Processed as non-conforming material.
- c. Labeled as failed ESDS material and the incident reported.

5.3.3 When a kit is assembled that includes an ESDS item, the entire kit and the accompanying documentation used to identify the kit shall be packaged and marked as ESDS.

5.3.4 ESDS items packaged for shipping shall be packaged and marked as required by the contract and in accordance with special instructions defined in these ESD implementation plan.

### 5.4 EQUIPMENT LEVEL TEST, MAINTENANCE, AND INSTALLATION

5.4.1 The following practices apply both within a facility and in the field when the equipment being serviced contains ESDS items:

- a. Personnel shall be properly grounded (e.g., using a wrist strap) before each maintenance action. Maintenance actions include adjustments, restoring covers, and tightening fasteners.
- b. Protective packaging of a replacement ESDS item shall be grounded to the equipment to dissipate any static charge before the package is opened.
- c. As an ESDS item is installed, contact with parts, electrical terminals, and circuitry shall be kept to a minimum.
- d. Failed ESDS items shall be placed in protective packaging after removal from the equipment to facilitate root cause analysis.
- e. Probing ESDS items with test leads shall be conducted only within a certified EPA.

5.4.2 ESD-protective covering or protective caps on external terminals, interconnecting cables, and connector assemblies shall not be removed until it is necessary to permit the installation.

5.4.3 The cable connector pins and cable shield (connector outer shell) shall be grounded prior to engaging a de-energized connector and cable with a mating receptacle that is connected to an ESDS item.

- a. Soft grounding shall be used to avoid rapid discharge.

### 5.5 IDENTIFICATION AND MARKING

5.5.1 The ESD Program Monitor shall properly identify all ESDS items, equipment, and assemblies in order to warn personnel before any potentially ESD-damaging procedure can be performed.

April 13, 2011

LPR 8739.21

- a. For this purpose, packing lists, inspection reports, travelers, and other paperwork accompanying the hardware shall contain ESDS labels and cautionary notes.

5.5.2 Alternative identification shall be applied when the prescribed marking is not available.

- a. Approved identification methods from ANSI/ESD S8.1-2007 shall be used.

5.5.3 The standard ESD Protective Item Symbol shall be used to identify items that are specifically designed to provide ESD protection for ESDS assemblies and devices.

- a. This Protective Item Symbol is illustrated in Figures 5-1 and 5-2.

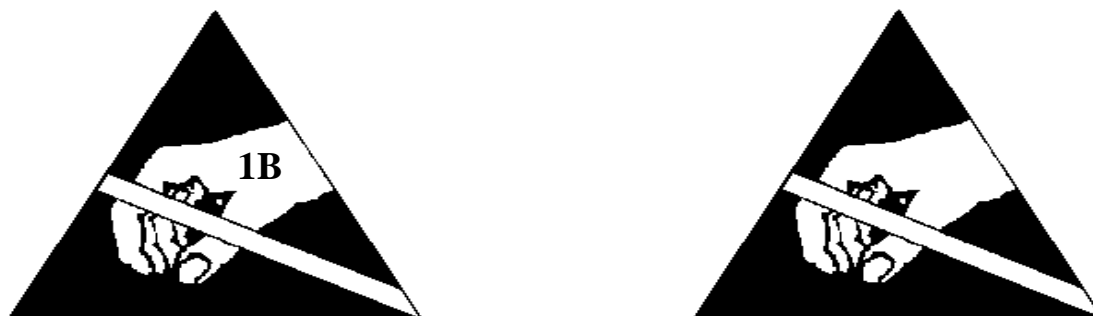

Figure 5-1: Sensitive Electronic Device Caution Symbol (with & without sensitivity class level)

*Note: If the Class sensitivity level is not specified within the symbol, or is other than Classes 0, M1, or C1, it will default to Class 1A. Refer to paragraph 2.3.1*



Figure 5-2: ESD Protective Item Symbol

5.5.4 The standard ESD common point ground symbol shall be used to indicate the location of an acceptable Common Point Ground (Figure 5.3).



Figure 5-3: ESD Common Point Ground Symbol



April 13, 2011

LPR 8739.21

## 6 ASSURANCE PROVISIONS

### 6.1 SURVEILLANCE

6.1.1 Project MAEs shall ensure that processes used for their project are properly controlled and meet requirements.

- a. MAEs or their designated representatives shall audit ESD controlled areas prior to beginning work on their flight hardware and ensure compliance to this document's requirements.

6.1.2 The area's ESD Program Monitor shall periodically verify EPAs (see Table 4-1).

6.1.3 The ESD POC (see section 2.6) is responsible for the initial certification of all EPAs.

- a. This task may be delegated to an audit team who represents the POC.

6.1.4 The ESD POC shall perform random audits where deemed necessary.

- a. This task may also be performed by any assigned auditor.

### 6.2 EPA "PASS" CERTIFICATION REQUIREMENTS

6.2.1 If the EPA meets the requirements of this NASA LaRC ESD CPP, then the ESD Program Monitor shall certify it as approved for use.

- a. The certifier shall initial, date, and record "Approved" on the LF 23 ESD Protected Area Test Log.

6.2.2 The certifier shall also affix a LF 382 Certification/Verification Sticker to the work area in a conspicuous location, but not in an area where ESDS items will be processed (e.g., workstation riser, front edge of work surface).

- a. For ESD workstations inside clean rooms or other restricted areas, sticker placement shall comply with the clean room's management requirements and positioned for clear visual access.

6.2.3 The EPA remains certified for use until a discrepancy is found during its use (e.g., broken ground wire, workstation was moved, or rewired) or the verification has not been performed in over 6 months.

- a. See abandoned EPAs in section 2.8.3.

### 6.3 EPA AREA "FAIL" REQUIREMENTS

6.3.1 If an EPA fails to meet the requirements of this ESD CPP, then the ESD Program Monitor shall mark the area with a LF 385, ESD Protected Area "Out of Service" Sign, in an obvious location.

- a. The person certifying the EPA shall initial, date, and post the LF 385 and provide a brief description of the problem on LF 23.
- b. The area shall remain out of service until the discrepant item(s) have been corrected and the ESD Protected Area Test Log has been updated to show the area acceptable for use.

April 13, 2011

LPR 8739.21

- c. When ESDS hardware has been handled in the area since the last passing verification, the hardware shall be handled as non-conforming material.

6.3.2 The NASA LaRC ESD POC and the department responsible for the area shall address discrepancies in a team environment in order to restore the area for use in as little time as practical.

- a. Disposition of ESDS items affected by the discrepancy is the responsibility of the organization that owns the items and the organization responsible for the area.

April 13, 2011

LPR 8739.21

## APPENDIX A DEFINITIONS

The following definitions apply to terms used in this manual:

- A.1 **Assembly** - A functional subdivision of a system consisting of subassemblies that performs functions necessary for the operation of the system as a whole. Examples: regulator assembly, power amplifier assembly, gyro assembly, and similar assemblies.
- A.2 **CAP Tracs** – The Langley Management System Corrective, Preventive, and Improvement Action Tracking System.
- A.3 **Certificate of Completion of Training** - The actual certificate issued or the wallet-sized card given to the trainee after successful completion of training.
- A.4 **Certification** - The act of verifying and documenting that personnel, facilities, equipment, processes, or materials comply with the requirements of this document.
- A.5 **Certification of Competence** - The act of verifying and documenting that personnel are competent to perform work in an EPA as required by this document.
- A.6 **Certification of Training** - The act of verifying and documenting that personnel has successfully completed training. The Certification of Completion of Training documents this certification.
- A.7 **Charged Device Model** - A specified circuit characterizing an electrostatic discharge, which results when a device isolated from ground is first charged and then subsequently grounded.
- A.8 **Cheater Plug** - An AC plug adapter used to connect a three-pronged plug to a two-pronged AC socket. It can be used to separate the ground wire from the socket for testing purposes.
- A.9 **Component** - A functional subdivision of a subassembly, generally a self-contained combination of parts performing a function necessary for the subassembly's operation. Examples: power supply, transmitter, gyro package, and similar parts.
- A.10 **Contractor** - The individual(s) or concern(s) that enter into a prime contract with the Government.
- A.11 **Conductive Material** - A material that has a surface resistivity of  $<10^5$  ohms per square or a volume resistivity  $<10^4$  ohms-cm.
- A.12 **Equipotential Bonding** - A connection between two points with a maximum resistance between them of  $< 10^9$  ohms [with no current flow].
- A.13 **Electrostatic Discharge (ESD)** - A transfer of electrostatic charge between bodies at different electrostatic potentials caused by direct contact or induced by an electrostatic field.
- A.14 **ESD ADV... ESDA Advisory Document** - Advisory Documents are not standards, but provide general information for the industry or additional information to aid in better understanding of ESD Association standards.
- A.15 **ESD DS... ESDA Draft Standard** - Draft standards, test methods and standard practices are subject to revision before being issued as full standards.

April 13, 2011

LPR 8739.21

- A.16 **ESD S...** **ESDA Standard** - Standards have completed the industry comment and review process, and have been approved by the ESD Association Standards Committee as final standards documents.
- A.17 **ESD SP...** **ESDA Standard Practice** - Standard practices have completed the industry comment and review process, and have been approved by the ESD Association Standards Committee as final standards documents.
- A.18 **ESD STM...** **ESDA Standard Test Methods** - Standard test methods have completed the industry comment and review process, and have been approved by the ESD Association Standards Committee as final standards documents.
- A.19 **ESD TR...** **ESDA Technical Report** - A technical report is a collection of technical data or test results published as an informational reference on a specific material, product, system or process. The opinions expressed in a technical report are the opinions of the author(s) and may or may not be endorsed by the ESD Association.
- A.20 **ESD Program Monitor** - An individual who is trained and certified who are responsible for the day-to-day maintenance of the certification status of an EPA.
- A.21 **EPA** - An area that is constructed and equipped with the necessary ESD-protective materials and equipment to limit ESD voltage below the sensitivity level of ESDS items handled therein. This may include benches, rooms or buildings.
- A.22 **ESD-Protective Material** - Material capable of one or more of the following functions: limiting the generation of static electricity; safely dissipating electrostatic charges over its surface or volume; or providing shielding from ESD spark discharge or electrostatic fields.
- A.23 **ESD-Protective Packaging** - Packaging with ESD-protective materials to prevent damage to ESDS items during storage or transport.
- A.24 **ESD Protected Workstation** - See EPA.
- A.25 **ESD Sensitive (ESDS) Items** - Electrical and electronic parts, assemblies and equipment which are sensitive to ESD voltages or electrostatic fields.
- A.26 **Electrostatic Field** - A voltage gradient between an electrostatically charged surface and another surface of a different electrostatic potential.
- A.27 **Ground** - A mass such as earth, a ship, or a vehicle hull, capable of supplying or accepting a large electrical charge.
- A.28 **Groundable Point** - Any point with low impedance to ground where grounding may be attached. Usually it is the common point ground.
- A.29 **Hard Ground** - A connection to earth ground either directly or through low impedance.
- A.30 **Human Body Model** - An electrostatic discharge circuit that meets the set model values by conforming to waveform criteria specified in ESD-STM 5.1, characterizing the discharge from the fingertip of a typical human being.
- A.31 **Insulative Material** - A material having a surface resistivity  $\geq 10^{12}$  ohms/square or a volume resistivity  $\geq 10^{11}$  ohms-cm.

April 13, 2011

LPR 8739.21

- A.32 **Kit** - A prepared package of parts with instructions for assembly and/or wiring a component or chassis.
- A.33 **Level B Instructor** - An individual who is certified to train Operators and ESD Program Monitors. Certified Level B Instructors are qualified to perform the duties of an ESD Program Monitor.
- A.34 **Machine Model** - An electrostatic discharge simulation test based on a discharge network consisting of a charged 200 Pico farad capacitor at (nominally) zero ohms of series resistance. Actual series resistance and inductance are specified in terms of the current waveform through a shorting wire. The simulation test approximates the electrostatic discharge from a machine. (See ESD STM 5.2)
- A.35 **Operator** - An individual who is trained and certified to perform tasks in an EPA.
- A.36 **Organization** - A NASA center, support contractor, supplier, department, group or team.
- A.37 **Part** - An element of a component, assembly, or subassembly which is not normally subject to further subdivision or disassembly without destruction of its designed use, e.g., a module, IC, resistor, and similar elements.
- A.38 **Soft Ground** - A connection to ground through impedance sufficiently high to limit current flow to safe levels for personnel (normally 5 milliamperes). Impedance needed for a soft ground is dependent upon the voltage levels which could be contacted by personnel near the ground. By this definition a hard ground protected by a functional GFCI is considered a soft ground.
- A.39 **Static Dissipative** - A property of a material having surface resistivity  $\geq 10^5$  but  $< 10^{12}$  ohms per square or a volume resistivity  $\geq 10^4$  but  $< 10^{11}$  ohms-cm.
- A.40 **Subcontractor** - An individual or concern that enters into a purchase agreement under a Government prime contract.
- A.41 **Surface Resistivity** - The surface resistivity is an inverse measure of the conductivity of a material. Surface resistivity of a material is numerically equal to the surface resistance between two electrodes forming opposite sides of a square. The size of the square is immaterial. Surface resistivity applies to both surfaces and materials with constant volume conductivity and has the value of ohms per square.
- A.42 **System** - A system is a functional subdivision of a spacecraft generally composed of two or more components designed to perform an operation. An instrument is considered a system.
- A.43 **Triboelectric** - Pertaining to electricity generated by friction.
- A.44 **Verification** - The act of performing the tests and/or inspections required in Table 4-1 and reviewing EPAs for compliance to the requirements of this Manual.

April 13, 2011

LPR 8739.21

**APPENDIX B****ACRONYMS**

<b>AC</b>	Alternating Current
<b>ATL</b>	Area Test Log
<b>CDM</b>	Charged Device Model [for electrostatic discharge].
<b>CMS</b>	Continuous Monitoring System
<b>CPG</b>	Common Point Ground
<b>EPA</b>	ESD Protected Area
<b>ESD</b>	Electrostatic Discharge
<b>ESDA</b>	Electrostatic Discharge Association
<b>ESD ADV</b>	Advisory Document
<b>ESDS</b>	Electrostatic Discharge Sensitive
<b>ESD DS</b>	Draft standards
<b>ESD S</b>	Standards
<b>ESD SP</b>	Standard Practices
<b>ESD STM</b>	Standard Test Methods
<b>ESD TR</b>	Technical Report
<b>GFCI</b>	Ground Fault Circuit Interrupter
<b>HBM</b>	Human Body Model [for electrostatic discharge]
<b>HR</b>	Humidity Ratio
<b>I&amp;T</b>	Integration and Test
<b>LPR</b>	Langley Procedural Requirement
<b>MAE</b>	Mission Assurance Engineer
<b>MM</b>	Machine Model [for electrostatic discharge]
<b>NASA</b>	National Aeronautics and Space Administration
<b>NMTTC</b>	NASA Manufacturing Technology Transfer Center
<b>QA</b>	Quality Assurance
<b>RH</b>	Relative Humidity
<b>RMS</b>	Root Mean Square
<b>SAM</b>	Systems Assurance Manager
<b>WM</b>	Workmanship Manual

April 13, 2011

LPR 8739.21

## **APPENDIX C EPA VERIFICATION TEST PROCEDURE**

### **C.1 Purpose**

This appendix provides an example of a procedure that a ESD Control Program Monitor can use to support verification checks in accordance with the ESD CPP.

### **C.2 Scope**

This document applies to personnel performing EPA tests or other ESD-related support for organizations who request such support.

### **C.3 Requirements**

#### **C.3.1 Personnel Requirements**

The organization shall ensure that:

- a. Their ESD Program Monitor has the appropriate resources and knowledge to implement this procedure (e.g., correct level of training, certification to act as a program monitor for the organization, proper equipment, and calibrated equipment).
  - (1) The monitor shall ensure that the verifications they perform are within specified time frames, records are current, and reports are issued as specified herein.
- b. Personnel providing ESD support have the appropriate level of training to perform the assigned task and are certified to work with ESDS items.
- c. Personnel assigned to this task verify calibration status of test and measuring equipment, make all necessary measurements and observations, and complete all appropriate forms and records as identified in this procedure (e.g., EPA ATL sheets, internal records).

#### **C.3.2 Equipment Calibration**

All test and measuring equipment used to perform the EPA Verification Test shall be in a current state of calibration.

### **C.4 Equipment List**

The following equipment, or equivalent, shall be used:

- a. 3M Model 701 Test Kit for Static Control Surfaces
- b. 3M Model 718 Static Sensor
- c. Monroe Electronics Model 287 Ionizer Performance Analyzer
- d. Fluke 77 DMM

### **C.5 Procedure**

#### **C.5.1 Verifications and Results**

C.5.1.1 The applicable elements of EPAs shall be verified by personnel currently certified in accordance with paragraph C.3.1 of this appendix.

April 13, 2011

LPR 8739.21

C.5.1.2 See Section 6 of this manual for personnel responsibilities. The frequency of verifications, conditions of tests, and limits shall be in accordance with Table 4-1 of this ESD CPP.

C.5.1.2.1 Area verifications shall be documented on the LF 23 ESD Protected ATL.

C.5.1.2.1.1 The EPA ATL shall be used for data entry.

C.5.1.2.2 Measurements shall be compared with previous data for the relevant area in order to identify trends toward a noncompliant condition.

C.5.1.2.2.1 If a trend is noted, the organization responsible for the EPA shall be notified so correction can be implemented before failure occurs.

## **C.5.2 Test Procedures**

### **C.5.2.1 Test 1: Work Surface Resistance**

C.5.2.1.1 This test shall be performed by measuring the resistance between two 5 pound, 2.5 inches diameter electrodes.

C.5.2.1.2 The electrodes shall be positioned 10 inches (25 cm) apart and at least 2 inches (5 cm) from the edge of the work surface.

C.5.2.1.3 Set the megohmmeter voltage to 100 V, then measure the resistance after 15 seconds, and record the value in the ATL.

C.5.2.1.4 The area shall be clean and dry prior to performing this test.

C.5.2.1.5 For older surfaces, the measurement shall be made on the most worn area.

### **C.5.2.2 Test 2: Work Surface Grounding**

C.5.2.2.1 Measure the resistance between the equipment ground (the nearest permanent electrical outlet ground) and the center of the work surface.

C.5.2.2.1.1 Use a 5-pound, 2.5-inches diameter electrode at the work surface.

C.5.2.2.1.2 Set the megohmmeter voltage to 100 V, then measure the resistance after 15 seconds, and record the value in the ATL.

C.5.2.2.2 When checking highly conductive surfaces, a GFCI outlet shall be used to protect personnel.

C.5.2.2.2.1 Check the GFCI using the self-test feature in the outlet.

C.5.2.2.2.2 Plug a lamp in the receptacle and press the TEST button in the GFCI.

C.5.2.2.2.3 The light must go out.

C.5.2.2.2.4 Unplug the lamp, press RESET, and record the result in the ATL.

*Note: Because this is a special test for ground check, when performed, the ATL example must be modified to accommodate it.*



April 13, 2011

LPR 8739.21

**C.5.2.3 Test 3: Floor Resistance**

C.5.2.3.1 Measure the resistance between two points on the “High Transit” area of the floor at least 12 inches apart.

C.5.2.3.2 Use a 5-pound, 2.5-inches diameter electrode at the work surface.

C.5.2.3.3 Set the megohmmeter voltage to 100 V, then measure the resistance after 15 seconds, and record the value in the ATL.

C.5.2.3.4 This is a minimum test for recertification only and can be used for either floor mats or conductive floors.

C.5.2.3.5 For initial certification of a newly installed conductive floor, follow the test procedure in ESD STM7.1-2001.

**C.5.2.4 Test 4: Floor Grounding**

C.5.2.4.1 Measure the resistance between the facility ground (the outlet ground) and a point on the floor at least 12 inches away from the floor-to-ground connection.

C.5.2.4.2 Use a 5-pound, 2.5-inches diameter electrode at the work surface.

C.5.2.4.3 Set the megohmmeter voltage to 100 V, then measure the resistance after 15 seconds, and record the value in the ATL.

C.5.2.4.4 This is a minimum test for verification only and can be used for either floor mats or ESD protective floors.

C.5.2.4.5 For initial certification of a newly installed ESD protective floor, follow the test procedure in ESD STM7.1-2001).

**C.5.2.5 Test 5: Wrist Strap Grounding**

C.5.2.5.1 Resistance shall be measured using an ohmmeter.

C.5.2.5.2 The measurement shall be made from the wrist strap groundable point to a facility ground in the nearest permanent electrical outlet.

C.5.2.5.3 Record resistance value in ATL.

**C.5.2.6 Test 6: Continuous Monitoring Systems**

C.5.2.6.1 Check that the CMS alarm activates when the ground is removed by using a “Cheater Plug,” and again by physically removing the cord from the wrist strap while wearing it.

C.5.2.6.2 This test shall be performed when the CMS is being tested for functionality or when there is doubt about the reliability of the CMS.

C.5.2.6.3 For a complete calibration of the CMS, use the manufacturer’s recommended fixture and test procedure.

April 13, 2011

LPR 8739.21

**C.5.2.7 Test 7: Stool and Chair Grounding**

C.5.2.7.1 Qualification tests for any seating used in an EPA shall be in accordance with ESD STM12.1-1997.

C.5.2.8.2 For verification tests, position a 5-pound, 2.5-inch diameter electrode at the center of the seating surface and measure the resistance to the chair's groundable point

C.5.2.8.2.1 A caster or grounding chain shall rest on a conductive surface;

C.5.2.8.2.2 Use of a metal plate may be necessary on non-conductive floors).

C.5.2.8.3 The test shall be repeated for the back and arms of the chair, if present.

C.5.2.8.4 Set the megohmmeter voltage to 100 V, measure after 15 seconds.

C.5.2.8.5 Record the largest resistance measured.

**C.5.2.8 Test 8: Humidity**

C.5.2.8.1 RH shall be constantly monitored using a calibrated hygrometer.

C.5.2.8.2 The hygrometer shall be in the same room and as close as possible to the work area.

C.5.2.8.3 Continuously recording chart recorders or automatic logging are recommended.

C.5.2.8.4 For places where there is no continuous record, a log shall be maintained by the organization responsible for the EPA.

C.5.2.8.5 The log shall document the humidity levels.

C.5.2.8.5.1 If the humidity levels are not within the acceptable limits the responsible organization's POC shall halt work and take steps to bring the humidity levels into acceptable limits.

C.5.2.8.6 Daily entries shall be made each time the EPA is in use.

C.5.2.8.7 The verifier shall record the current RH in the ATL and review the humidity charts/log for large variations in humidity, which indicate that more frequent checks may be necessary.

**C.5.2.9 Test 9: Ionizers**

C.5.2.9.1 For most applications, ionizer performance is considered acceptable as long as the ionizer is in a current status of calibration.

C.5.2.9.1.1 Ionizer average decay rate and ion balance shall be measured in accordance with ESD Association Standard Practice ESD SP3.3-2000.

C.5.2.9.2 The limits for decay and balance measurements are determined by the ESD classification of the EPA being verified. See Table 4-2.

C.5.2.9.3 Because some ionizers tend to collect dust and lose their effectiveness, periodic cleaning and verification of all air ionizers is recommended.

C.5.2.9.4 The verification tests can be done using a Monroe Electronics Ionizer Performance Analyzer Model 287 or equivalent instrument(s) capable of making the measurements contained in ESD SP3.3-2000.

April 13, 2011

LPR 8739.21

C.5.2.9.4.1 Follow the instrument manufacturer's operating instructions.

C.5.2.9.4.2 Record decay time and balance on the ATL.

### **C.5.2.10 Test 10: Soldering Iron Tip to Ground**

C.5.2.10.1 Soldering iron tips may be checked using a DMM and a FR-4 copper-clad PC Board of size 2 by 0.5 inches.

C.5.2.10.2 Attach one lead of the DMM to the AC outlet common ground and the other lead to the PC Board.

C.5.2.10.2.1 Set the meter to measure AC voltage.

C.5.2.10.3 After the iron is at operating temperature, melt a small pool of solder with the tip of the iron on the far end of the PC Board and monitor the AC voltage on DMM.

C.5.2.10.3.1 It should measure <2.0 mV AC.

*Caution: If this test fails, STOP the following tests and replace the soldering iron.*

C.5.2.10.4 Set the DMM to read ohms, then melt the solder pool using the soldering iron and check the resistance value on the DMM.

C.5.2.10.4.1 The resistance should be <1 ohm when certifying a new soldering station and <20 ohms during periodic verification.

C.5.2.10.5 For soldering irons with integral protection, use the manufacturer's recommended procedures to check proper circuit operation.

### **C.5.2.11 Test 11: Equipment & Facility Grounding**

C.5.2.11.1 Measure the resistance between the main service box neutral bond and the EPA CPG.

C.5.2.11.2 This test may require the assistance of the maintenance department to access the neutral bond at the main service box.

C.5.2.11.3 A quick check can be done using a commercial socket tester.

*Note: This test is only required during initial certification of an EPA or if the electrical system in the area has been serviced or modified.*

C.5.2.11.4 When an auxiliary ground (e.g., quiet ground) is used, resistance between the equipment ground and the auxiliary ground shall not exceed 25 ohms.

### **C.5.3 Reporting**

C.5.3.1 The verification activity, if not performed by the ESD Program Monitor, will provide a summary report to the ESD Program Monitor responsible for the area.

C.5.3.1.1 These reports shall be retained as described in paragraph 4.3.

April 13, 2011

LPR 8739.21

#### **C.5.4 Out of Calibration Test Equipment**

C.5.4.1 Only test and measuring equipment in a current state of calibration shall be used.

C.5.4.2 If a piece of test or measuring equipment is returned from the calibration contractor indicating it was received in an “out of tolerance” condition, records shall be reviewed to determine which EPAs were verified using that piece of equipment since its last known “good” status.

C.5.4.2.1 A Nonconformance Report shall be prepared documenting the impact of the out-of-tolerance condition on all products or services processed in the areas in question since the last acceptable assessment of calibration.

C.5.4.2.2 The ESD Program Monitor shall notify all affected organization(s) and supply them with as much information as possible for them to use in their impact analyses (e.g., dates of prior verifications, how far out of tolerance the equipment was found to be).