

METRIC/INCH-POUND

KSC-W-167B

July 25, 1994

Supersedes

KSC-W-167A

March 18, 1974

WIRING PROGRAMMING SYSTEM PATCHBOARDS, SPECIFICATION FOR

ENGINEERING DEVELOPMENT DIRECTORATE

National Aeronautics and
Space Administration

John F. Kennedy Space Center



METRIC/INCH-POUND

KSC-W-167B
July 25, 1994
Supersedes
KSC-W-167A
March 18, 1974

WIRING PROGRAMMING SYSTEM PATCHBOARDS, SPECIFICATION FOR

ENGINEERING DEVELOPMENT DIRECTORATE

National Aeronautics and
Space Administration
John F. Kennedy Space Center

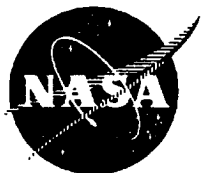

KSC-W-167B

July 25, 1994

Supersedes

KSC-W-167A

March 18, 1974

WIRING PROGRAMMING SYSTEM PATCHBOARDS, SPECIFICATION FOR

Approved By:

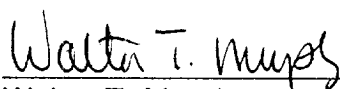

Walter T. Murphy
Director of Engineering Development

JOHN F. KENNEDY SPACE CENTER, NASA

TABLE OF CONTENTS

| <u>Section</u> | <u>Title</u> | <u>Page</u> |
|----------------|--------------------------------------|-------------|
| 1. | SCOPE | 1 |
| 2. | APPLICABLE DOCUMENTS | 1 |
| 2.1 | Governmental | 1 |
| 2.1.1 | Specifications | 1 |
| 2.1.2 | Drawings | 2 |
| 3. | REQUIREMENTS | 2 |
| 3.1 | Material | 2 |
| 3.1.1 | Patchboards | 2 |
| 3.1.2 | Patchcord Pins | 2 |
| 3.1.3 | Wire | 2 |
| 3.1.4 | End Caps | 2 |
| 3.1.5 | Heat-Reactive Tubing | 3 |
| 3.2 | Tools | 3 |
| 3.2.1 | Crimping Tools | 3 |
| 3.2.2 | Extraction Tools | 6 |
| 3.2.3 | Stripping Tools | 6 |
| 3.2.4 | Heat-Application Method | 6 |
| 3.3 | Wiring Procedure | 6 |
| 3.3.1 | Patchcord-Pin Installation | 6 |
| 3.3.2 | Multipatch Jumper Installation | 6 |
| 3.3.3 | End-Cap Capacity | 6 |
| 4. | QUALITY ASSURANCE PROVISIONS | 6 |
| 4.1 | Inspection and Test | 6 |
| 4.2 | Discrepancies | 7 |
| 4.2.1 | Material | 7 |
| 4.2.1.1 | Wire | 7 |
| 4.2.1.2 | End Caps | 7 |
| 4.2.2 | Workmanship | 7 |
| 4.2.2.1 | End-Cap Crimp | 7 |
| 4.2.2.2 | Patchcord-Pin Crimp | 7 |
| 4.2.2.3 | Patchcord-Pin Inspection | 7 |
| 4.2.2.4 | Patchcord-Pin Retention | 7 |

KSC-W-167B
July 25, 1994

TABLE OF CONTENTS (cont)

| <u>Section</u> | <u>Title</u> | <u>Page</u> |
|----------------|--------------------------------|-------------|
| 5. | PREPARATION FOR DELIVERY | 7 |
| 6. | NOTES | 8 |

LIST OF FIGURES

| <u>Figure</u> | | <u>Page</u> |
|---------------|--|-------------|
| 1. | Patchcord Pins | 4 |
| 2. | Multipatch Wiring Arrangements: Jumpers and End Caps . | 5 |

KSC-W-167B
July 25, 1994

WIRING PROGRAMMING SYSTEM PATCHBOARDS,
SPECIFICATION FOR

1. SCOPE

This specification establishes the procedures and lists the equipment required for wiring the programming system patchboards.

2. APPLICABLE DOCUMENTS

The following documents form a part of this document to the extent specified herein. When this document is used for procurement, including solicitations, or is added to an existing contract, the specific revision levels, amendments, and approval dates of said documents shall be specified in an attachment to the Solicitation/Statement of Work/Contract. In the event of conflict between the documents referenced herein and the contents of this specification, the contents of this specification shall be considered a superseding requirement.

2.1 Governmental.

2.1.1 Specifications.

John F. Kennedy Space Center (KSC), NASA

| | |
|-----------|--|
| KSC-E-165 | Electrical Ground Support Equipment, Fabrication, Specification for |
|-----------|--|

Military

| | |
|---------------|--|
| MIL-C-22520/1 | Crimping Tools, Terminal, Hand, Wire Termination for Wire Barrel Sizes 12 Through 20 |
|---------------|--|

| | |
|---------------|--|
| MIL-C-22520/5 | Crimping Tools, Terminal, Hand, Wire Termination, Large for Coaxial, Shielded Contacts and Ferrules, Terminal Lugs, Splices, and End Caps |
|---------------|--|

| | |
|-------------|--|
| MIL-I-23053 | Insulation Sleeving, Electrical, Heat Shrink- able, General Specification for |
|-------------|--|

KSC-W-167B
July 25, 1994

| | |
|-------------|--|
| MIL-W-16878 | Wire, Electrical, Silicone, Rubber Insulated, 200 Deg. C, 600 Volts |
| MS3191-1 | Tool, Hand, Crimp, Class 1 for Contacts of Electric Connectors |
| MS25274 | Cap, Electrical (Wire End, Crimp Style, Type II, Class 1) for 105 Deg. C Total Conductor Temperature |

2.1.2 Drawings.

John F. Kennedy Space Center (KSC), NASA

| | |
|----------|---|
| 79K22638 | Solderless Electrical Connections (Supersedes 75M05668) |
|----------|---|

(Copies of specifications, standards, drawings, and publications required by suppliers in connection with specific procurement functions should be obtained from the procuring activity or as directed by the Contracting Officer.)

3. REQUIREMENTS

3.1 Material.

3.1.1 Patchboards. - Patchboards programming systems manufactured by Anderson Electric Company, AMP Inc., or an approved equal determined by the Contracting Officer's technical representative shall be used.

3.1.2 Patchcord Pins. - Patchcord pins manufactured by Anderson Electric Company, AMP Inc., or an approved equal determined by the Contracting Officer's technical representative shall be used. (See table 1 and figure 1.)

3.1.3 Wire. - No. 20 American wire gage (AWG) wire shall be used for the patchcords. Wire shall conform to MIL-W-16878, types B or J, 19 strand, color white.

3.1.4 End Caps. - For multipatch wiring, end caps conforming to MS25274 and manufactured by Thomas & Betts, AMP Inc., or an approved equal determined by the Contracting Officer's technical representative shall be used to make the pigtail splice. (See figure 2.)

3.1.5 Heat-Reactive Tubing. - Tubing conforming to MIL-I-23053 shall be used throughout the program.

3.2 Tools.

3.2.1 Crimping Tools. - For crimping of patchcord pins and end caps, only the crimping tool specified by the manufacturer or the Contracting Officer's technical representative shall be used. (See table 1.) Crimping tools shall be inspected prior to the beginning of initial work and at periodic intervals not to exceed 40 hours of work service or 30 days of time, whichever occurs first. The tools shall be inspected for wear and clearances between dies and limits. The clearances and dimensions shall conform to the respective standards or to the dimensions approved by the Contracting Officer's technical representative.

Table 1. Patchcord Pins and End Caps

| Item | Part Number | Crimping Tool | Extraction Tool | Approved Source | |
|--|----------------------------|--|-----------------|-----------------|--------------------|
| | | | | Item | Tool |
| Anderson Patchcord Pin | Anderson C-4777-G | Military Tool MIL-C-22520/1-01; MS3191-1 | Anderson C-4853 | Anderson | Anderson; Buchanan |
| AMP Patchcord Pin (With Insulation) | AMP 397050-2 | AMP Basic Tool 47386; AMP Pin Stop SA 20-004 | AMP 305183 | AMP Inc. | AMP Inc. |
| AMP Patchcord Pin (Without Insulation) | AMP 397434-1 | Military Tool MIL-C-22520/1-01; Buchanan Positioner 4461-1 | AMP 305183 | AMP Inc. | AMP Inc.; Buchanan |
| Thomas & Betts End Caps | Thomas & Betts RB-15 RC-15 | Military Tool MIL-C-22520/5 | None Required | Thomas & Betts | Thomas & Betts |
| AMP End Caps | AMP 328308 328309 | Military Tool MIL-C-22520/5 | None Required | AMP Inc. | AMP Inc. |

KSC-W-167B
July 25, 1994

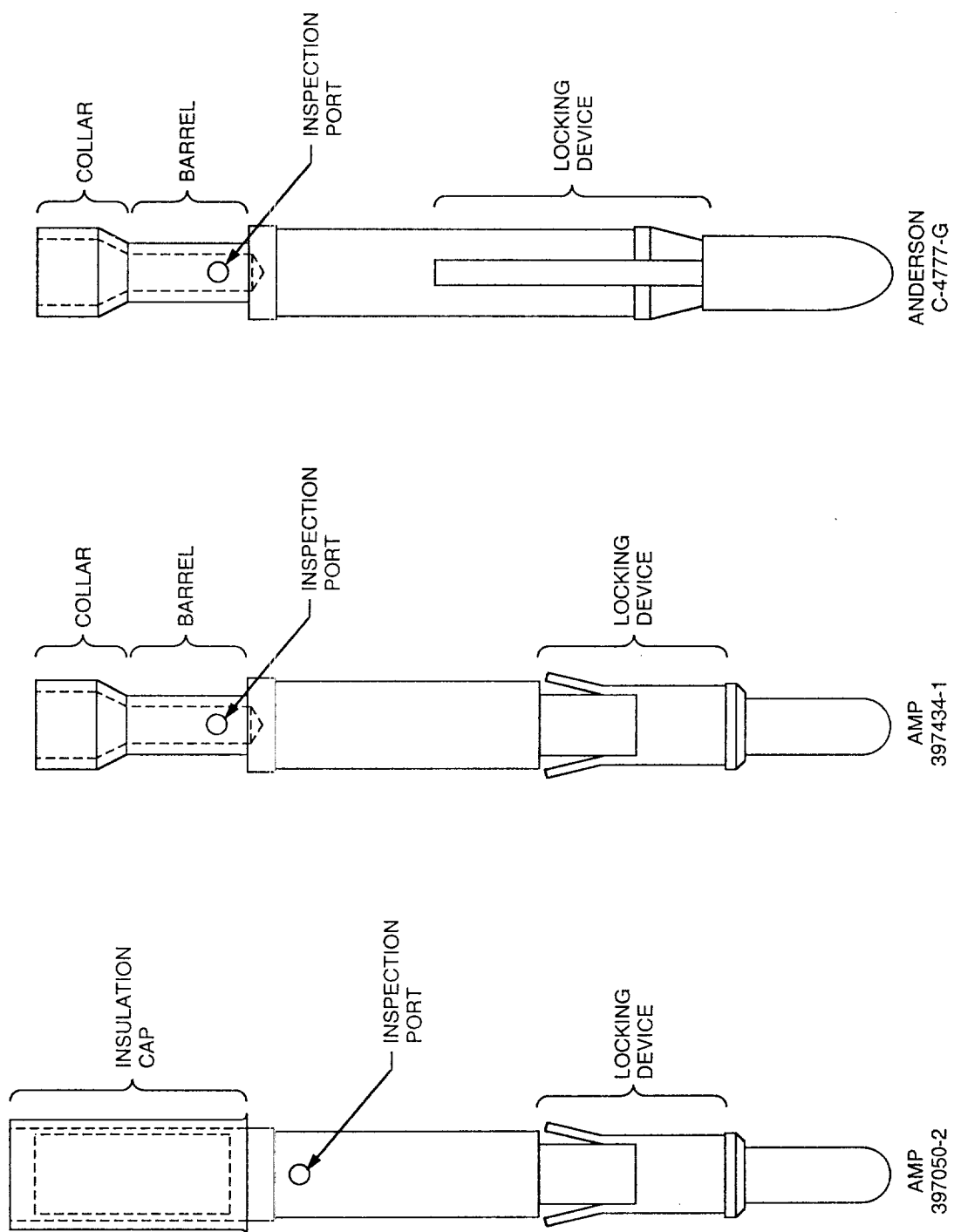
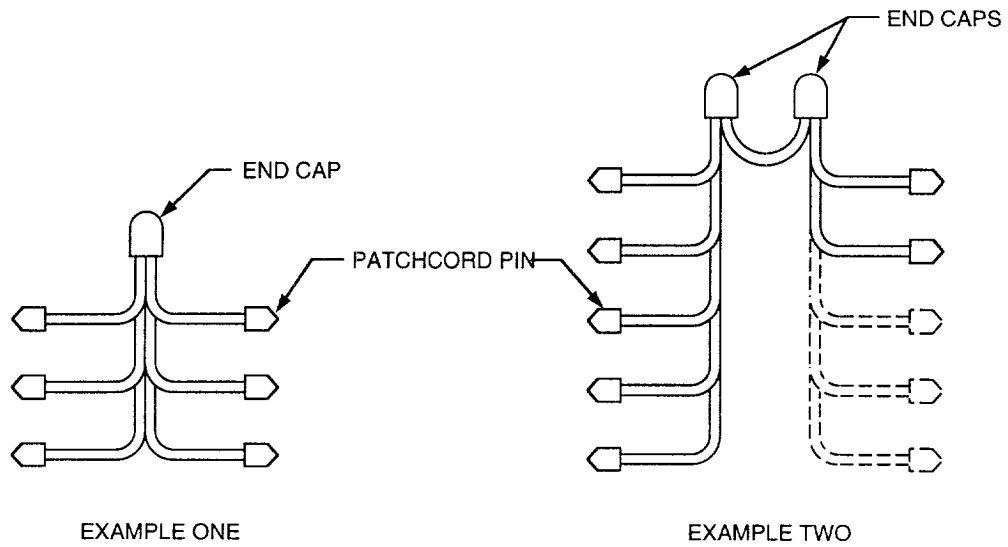
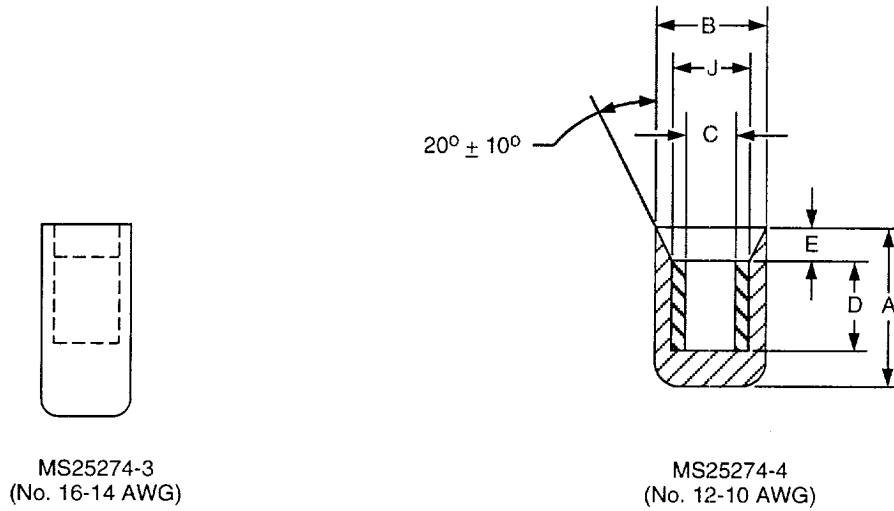

Figure 1. Patchcord Pins

DK/KSC-W-167B/FIG 1-1



JUMPERS



END CAPS

| WIRE CAPACITY (No. 20 AWG) | WIRE SIZE (AWG) | A | B | C | | D | E | J | COLOR CODE |
|-------------------------------|--------------------|-------|-------|-------|-------|-------|-------|-------|------------|
| | | MAX | MAX | MAX | MIN | MAX | MIN | MAX | |
| 2-3 | 16-14 | 0.480 | 0.245 | 0.090 | 0.080 | 0.305 | 0.082 | 0.170 | BLUE |
| 4-6 | 12-10 | | 0.315 | 0.140 | 0.129 | 0.345 | | 0.229 | YELLOW |

DKKSC-W-167B/FIG 1-2

Figure 2. Multipatch Wiring Arrangements: Jumpers and End Caps

KSC-W-167B
July 25, 1994

3.2.2 Extraction Tools. - Only approved extraction tools shall be used for the extraction of patchcord pins. (See table 1.)

3.2.3 Stripping Tools. - Thermal strippers shall be used in stripping insulation from individual conductors. Under conditions where the type of insulation or the wire size will not permit use of a thermal stripper, a mechanical type shall be used. Ideal Stripmaster stripper 16-26 or an approved equal determined by the Contracting Officer's technical representative is acceptable.

3.2.4 Heat-Application Method. - A thermal gun is recommended as the source for applying heat to the heat-reactive tubing to ensure a proper fit. However, an oven or radiation heat will be acceptable. A thermal gun with a temperature range of 400 to 540 degrees Celsius (°C) [750 to 1000 degrees Fahrenheit (°F)] (i.e., Master Appliances Corporation NSN 4940-00-986-5899 or approved equal determined by the Contracting Officer's technical representative) is acceptable.

3.3 Wiring Procedure.

3.3.1 Patchcord-Pin Installation. - To install the patchcord pins on the wire, (1) remove the insulation from the end of the wire with a thermal stripper to the length required, according to the depth of the pin barrel; (2) slip a 1/2-inch piece of heat-reactive tubing (except when using AMP 397050-2) over each end of the wire; (3) insert the stripped wire into the barrel of the patchcord pin until the wire can be seen through the inspection port, ensuring the wire insulation extends down inside the collar of the patchcord pin and then crimp with the specified crimping tool (see table 1); and (4) slip the heat-reactive tubing over the patchcord pin cap and barrel and then heat the tubing.

3.3.2 Multipatch Jumper Installation. - When multipatch jumpers and end caps are ready for installation, (1) lay white pre-cut jumpers neatly atop the installed patchcord jumpers, (2) cut to the desired length, (3) strip the insulation from the wire ends, (4) install the end cap, and (5) crimp, using the specified crimping tool. (See table 1.)

3.3.3 End-Cap Capacity. - Not more than six wires shall be installed in any one end cap. Should it be desirable to join more than six wires, two or more caps shall be used in an arrangement as that shown in figure 2, example 2.

4. QUALITY ASSURANCE PROVISIONS

4.1 Inspection and Test. - The supplier shall be responsible for the performance of all inspection and test requirements specified herein. Except as otherwise specified, the supplier may utilize his own or any other inspection and test

facilities and services acceptable to NASA. Inspection and test records shall be kept complete and, upon request, shall be made available to the Contracting Officer. The Contracting Officer reserves the right to perform any or all of the inspections and tests set forth in the specification to ensure the end item conforms to the prescribed requirements.

4.2 Discrepancies. - The following discrepancies shall be sufficient reason for rejection of the patchboard.

4.2.1 Material. - Only materials specified herein or as approved by the Contracting Officer shall be acceptable.

4.2.1.1 Wire. - Improper gage, insufficient or excessive length, twisted or kinked wire, or broken insulation shall be reason for rejection.

4.2.1.2 End Caps. - Nonapproved end caps or end caps with broken insulation, cracked ferrules, or of the wrong color shall be cause for rejection.

4.2.2 Workmanship.

4.2.2.1 End-Cap Crimp. - Improper crimp of end caps from improper crimping tools or crimping die sets, improper location of crimp, or a crimp that cannot withstand the tensile strength test specified in MS25274 shall be sufficient reasons for rejecting the patchboard and returning it for rework.

4.2.2.2 Patchcord-Pin Crimp. - Improper crimp as called out in 79K22638 of patchcord pins from improper crimping tools or locator or improper locations of crimp shall cause the patchcord jumper to be rejected.

4.2.2.3 Patchcord-Pin Inspection. - The stripped end of the jumper wire shall be visible through the patchcord-pin inspection port or the patchcord shall be rejected. Likewise, nicks, rings, gouges, or scrapes on jumper wire caused by stripping shall cause the patchcord to be rejected. Inspection shall be performed after crimping but prior to placing and shrinking the heat-reactive tubing.

4.2.2.4 Patchcord-Pin Retention. - Inability of the installed patchcord pins to withstand the specified force [approximately 22 newtons (5 pounds)] applied to the tip of the pin shall be reason for rejection, and the patchboard shall be returned for rework.

5. PREPARATION FOR DELIVERY

There are no applicable requirements.

KSC-W-167B
July 25, 1994

6. NOTES

NOTICE: The Government drawings, specifications, and/or data are prepared for the official use by, or on the behalf of, the United States Government. The Government neither warrants these Government drawings, specifications, or other data, nor assumes any responsibility or obligation, for their use for purposes other than the Government project for which they were prepared and/or provided by the Government, or an activity directly related thereto. The fact that the Government may have formulated, furnished, or in any way supplied the said drawings, specifications, or other data is not to be regarded, by implication or otherwise, as licensing in any manner the holder or any other person or corporation, nor conveying the right or permission, to manufacture, use, or sell any patented invention that may relate thereto.

Custodian:

NASA - John F. Kennedy Space Center
Kennedy Space Center, FL 32899

Preparing Activity:

John F. Kennedy Space Center
Electronic Engineering
Engineering Development Directorate

STANDARDIZATION DOCUMENT IMPROVEMENT PROPOSAL

INSTRUCTIONS

1. The preparing activity must complete blocks 1, 2, 3, and 8. In block 1, both the document number and revision letter should be given.
2. The submitter of this form must complete blocks 4, 5, 6, and 7.
3. The preparing activity must provide a reply within 30 days from receipt of the form.

NOTE: This form may not be used to request copies of documents, nor to request waivers or clarification of requirements on current contracts. Comments submitted on this form do not constitute or imply authorization to waive any portion of the referenced document or to amend contractual requirements.

I RECOMMEND A CHANGE:

1. DOCUMENT NUMBER

KSC-W-167B

2. DOCUMENT DATE

July 25, 1994

3. DOCUMENT TITLE

Wiring Programming System Patchboards, Specification for

4. NATURE OF CHANGE *(Identify paragraph number and include proposed rewrite, if possible. Attach extra sheets as needed.)*

5. REASON FOR RECOMMENDATION

6. SUBMITTERa. NAME *(Last, First, Middle Initial)*

b. ORGANIZATION

c. ADDRESS *(Include Zip Code)*d. TELEPHONE *(Include Area Code)*

7. DATE SUBMITTED

8. PREPARING ACTIVITY

a. NAME

Director of Engineering Development

d. TELEPHONE *(Include Area Code)*

407-867-2565

c. ADDRESS *(Include Zip Code)*National Aeronautics and Space Administration, Mail Code: DE,
Kennedy Space Center, Florida 32899