

45

KSC-SPEC-E-0002
March 15, 1967
Supersedes KSC-E-153
January 21, 1964



**JOHN F. KENNEDY
SPACE CENTER**

SPECIFICATION

for

**MODULAR ENCLOSURES (Cabinets , Consoles) and ACCESSORIES ,
RADIO FREQUENCY INTERFERENCE SHIELDED**

ELECTRICAL/ELECTRONIC SYSTEMS DIVISION

KSC-SPEC-E-0002
Amendment 1
April 1, 1967

JOHN F. KENNEDY SPACE CENTER, NASA
MODULAR ENCLOSURES (Cabinets, Consoles) and
ACCESSORIES, RADIO FREQUENCY INTERFERENCE SHIELDED

This amendment forms a part of Kennedy Space Center Specification KSC-SPEC-E-0002, March 15, 1967, and is approved for use by KSC and associated contractors.

Each page: Change so much of each page heading as reads...Supersedes KSC-E-153 January 21, 1964, to read...Supersedes KSC-E-153F (Rev. "A") 25 May 1964.

Custodian:

NASA-Kennedy Space Center

Preparing Activity:

Kennedy Space Center

KSC-SPEC-E-0002
March 15, 1967
Supersedes KSC-E-153
January 21, 1964

JOHN F. KENNEDY SPACE CENTER, NASA

SPECIFICATION

for

MODULAR ENCLOSURES (Cabinets, Consoles) and ACCESSORIES,
RADIO FREQUENCY INTERFERENCE SHIELDED

Authentication:



J. R. White
Electrical/Electronics
Systems Division

KSC-SPEC-E-0002
 March 15, 1967
 Supersedes KSC-E-153
 January 21, 1964

CONTENTS

Paragraph		Page
1.	SCOPE	1
2.	APPLICABLE DOCUMENTS.	1
3.	REQUIREMENTS.	3
3.1	Enclosure Configuration and Dimensioning	3
3.2	Accessory Configuration and Dimensioning.	3
3.3	Materials	4
3.4	Standard Hardware	4
3.5	Nonstandard Hardware	4
3.6	Mounting Holes	4
3.7	Sharp Projections.	4
3.8	Welding	25
3.9	Frame Structure Rigidity	25
3.10	Interior Distributed Load	25
3.11	Fastening Devices Installation	25
3.12	Door Options	25
3.13	Lifting Eyes	27
3.14	Finish.	27
3.15	Component Identification	27
3.16	Component Interchangeability.	27
3.17	Shielding	27
4.	QUALITY ASSURANCE PROVISIONS.	28
4.1	General	28
4.2	Sampling	28
4.3	Acceptance Requirements.	28
4.4	Inspection and Test Requirements	28
5.	PREPARATION FOR DELIVERY	36
6.	NOTES	36

KSC-SPEC-E-0002
 March 15, 1967
 Supersedes KSC-E-153
 January 21, 1964

LIST OF ILLUSTRATIONS

Figure No.	Title	Page
1	Vertical Cabinet.	5
2	Slope Front Console	7
3	Low-Silhouette Console	9
4	Test Director Special Console	11
5	Base.	12
6	Intermediate Bar.	14
7	Joiner Frames and Lifting Eyes.	15
8	Corner Angle Joiner Units.	17
9	Hinged Door.	19
10	Panel Mounted Utility Drawer (RFI Tight)	22
11	Retractable Writing Surface (RFI Tight).	23
12	Panel Mounted Writing Surface	24
13	Exterior Load Test Set-Up	26
14	Design Details 1/4 Wave Vertical Antenna	34
15	Signal Source Location	37
16	RFI Test Set-Up (Enclosure Front).	38
17	Minimum Attenuation Limits	39
18	RFI Test Set-Up (Enclosure Rear)	40

LIST OF TABLES

Table No.	Title	Page
1	Test Equipment Combinations	33

KSC-SPEC-E-0002
March 15, 1967
Supersedes KSC-E-153
January 21, 1964

JOHN F. KENNEDY SPACE CENTER
NATIONAL AERONAUTICS AND SPACE ADMINISTRATION
SPECIFICATION

for

MODULAR ENCLOSURES (Cabinets, Consoles) and ACCESSORIES,
RADIO FREQUENCY INTERFERENCE SHIELDED

This specification has been approved by the Electrical/Electronics Systems Division of the John F. Kennedy Space Center (KSC) for use by KSC and associated contractors.

1. SCOPE

1.1 Scope. - This specification establishes the requirements for radio frequency interference (RFI) shielded modular enclosures (cabinets, consoles) and accessories as listed herein. Where the provisions of other specifications or standards and this specification conflict, the provisions of this specification shall govern.

2. APPLICABLE DOCUMENTS

2.1 The following documents form a part of this specification to the extent specified herein. Unless otherwise indicated, the issue in effect on the date of invitation for bids shall apply.

SPECIFICATIONS

Federal

QQ-P-416

Plating, Cadmium, Electrodeposited

Military

MIL-W-6858

Welding, Resistance: Aluminum, Magnesium, Non-Hardening Steels or Alloys, Nickel Alloys, Heat Resisting Alloys, and Titanium Alloys; Spot and Seam

KSC-SPEC-E-0002
March 15, 1967
Supersedes KSC-E-153
January 21, 1964

STANDARDS

Federal

FED-STD-595 Colors

Military

MIL-STD-130 Identification Marking of U.S. Military
Property

MIL-STD-171 Finishing of Metal and Wood Surfaces

MS33586 Metals, Definition of Dissimilar

George C. Marshall Space Flight Center (MSFC)

MSFC-STD-156 Riveting, Fabrication, and Inspection,
Standard for

OTHER PUBLICATIONS

National Aeronautics and Space Administration (NASA)

NPC 200-3 Inspection System Provisions, Suppliers
of Space Materials, Parts, Components,
and Services

(Copies of specifications, standards, or NASA publications required by suppliers in connection with specific procurement functions should be obtained from the procuring activity or as directed by the contracting officer.)

Electronic Industries Association (EIA)

EIA Standard SE 102 Racks, Panels and Associated Equipment

(Application for copies should be addressed to the Electronic Industries Association, Engineering Department, 11 W 42nd Street, New York, 36, N.Y.)

KSC-SPEC-E-0002
March 15, 1967
Supersedes KSC-E-153
January 21, 1964

Official Classification Committee

Uniform Classification Rules

(Application for copies should be addressed to the Official Classification Committee, 1 Park Avenue at 33rd Street, New York 16, N.Y.)

National Classification Board

National Motor Freight Classification Rules

(Application for copies should be addressed to the National Classification Board, 1616 P Street N.W., Washington 6, D.C.)

3. REQUIREMENTS

3.1 Enclosure Configuration and Dimensioning. - This specification concerns the following specific types of enclosures. Each produced enclosure shall conform to the configuration and critical dimensioning without the use of shims, shown in the referenced figure.

- (a) Vertical cabinet (figure 1)
- (b) Slope front console (figure 2)
- (c) Low silhouette console (figure 3)
- (d) Test director special console (figure 4)

3.2 Accessory Configuration and Dimensioning. - This specification concerns the following specific types of accessories that are for use with the referenced enclosures. Each produced accessory shall conform to the configuration and critical dimensioning without the use of shims, shown in the referenced figure.

- (a) Base (figure 5)
- (b) Intermediate bar (figure 6) Note: Bar is used to provide shielding continuity of installed accessories and chassis arrangements as required.
- (c) Joiner frame, open or baffled (figure 7) Note: Frame is used to provide multiple-bay enclosure arrangements.

KSC-SPEC-E-0002
March 15, 1967
Supersedes KSC-E-153
January 21, 1964

- (d) Corner angle joiner unit (figure 8) Note: Unit is used to provide angled multiple-bay enclosure arrangements.
- (e) Hinged door (figure 9)
- (f) Panel-mounted utility drawer (RFI tight) (figure 10)
- (g) Retractable writing surface (RFI tight) (figure 11)
- (h) Panel-mounted writing surface (figure 12)
- (i) Lifting eyes (figure 7)

3.3 Materials. - The selection of required materials shall be at the discretion of the manufacturer excepting writing surface covering, which shall be as specified in paragraph 3.14.3. Materials selected shall be such that the enclosure will meet the structural, environmental, and attenuation requirement specified herein.

3.3.1 Dissimilar Metals. - Dissimilar metals, as defined in MS33586, should not be used in combination. If used in combination, dissimilar metals shall be suitably treated in accordance with MIL-STD-171 for prevention of electrolytic corrosion without degradation of shielding effectiveness.

3.4 Standard Hardware. - Supplier shall select plated fastening devices and other common hardware items conforming to applicable Military Standards for the types and sizes required where feasible. Supplier shall ensure that items selected have been cadmium plated in accordance with Class 2, Type II, requirements of QQ-P-416; such plating must meet the requirements of QQ-P-416 (paragraph 3.4.2) or be rejected.

3.5 Nonstandard Hardware. - Plated nonmilitary standard items selected shall meet plating requirements of 3.4. Supplier may recommend for approval selected hardware items, providing they possess proven equal strength and proven better resistance to both electrolytic and environmental corrosion.

3.6 Mounting Holes. - Mounting holes shall be 9/32 inch in diameter, free from burrs, and spaced in conformance with the universal spacing requirements of EIA Standard SE 102.

3.7 Sharp Projections. - Sharp corners or edges that are potentially hazardous to personnel or damaging to equipment shall be ground smooth.

KSC-SPEC-E-0002
 March 15, 1967
 Supersedes KSC-E-153
 January 21, 1964

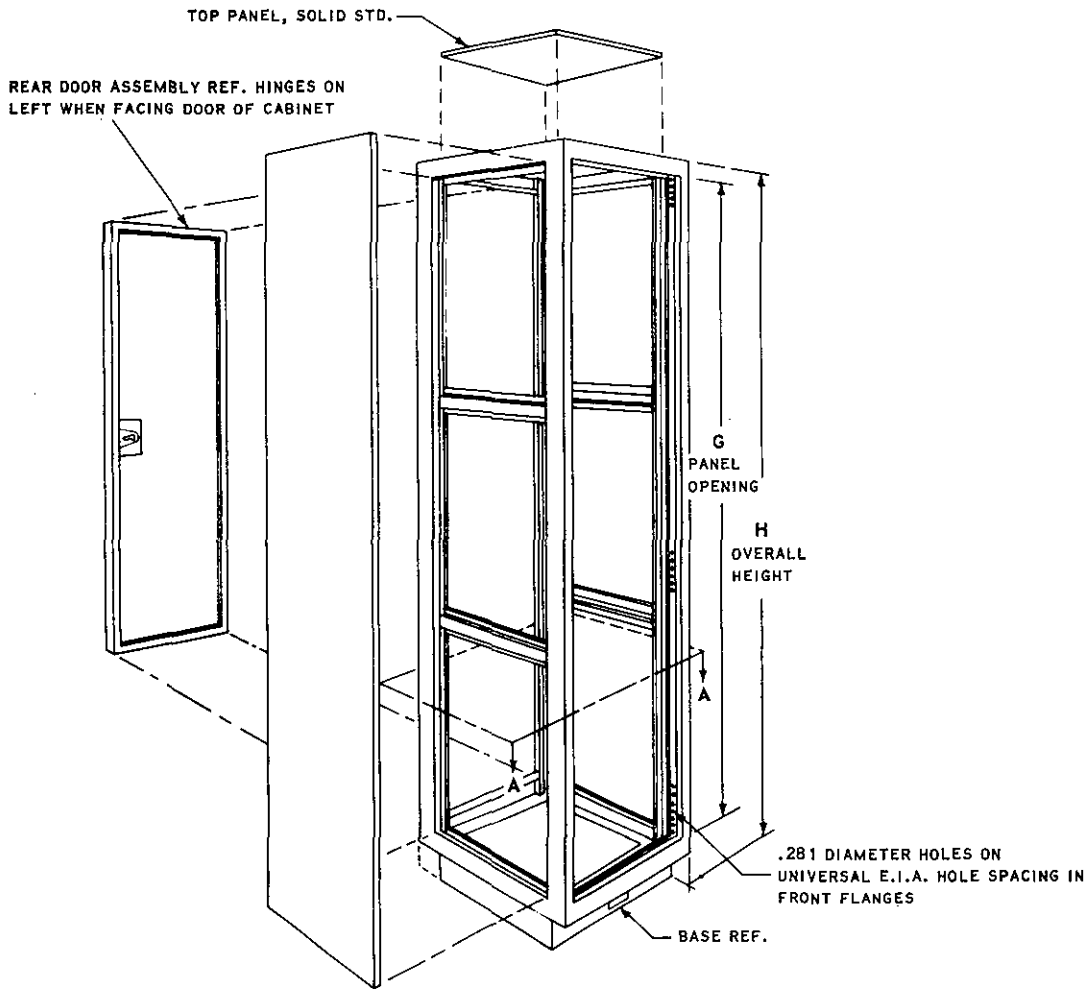

SECTION A-A

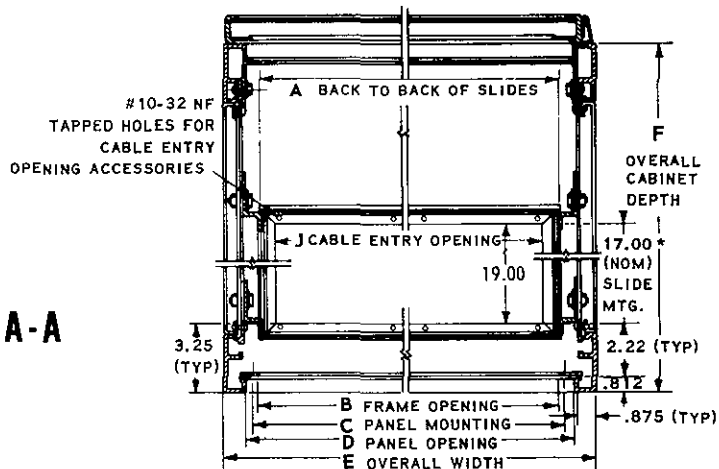

*UNIVERSALLY ADJUSTABLE

Figure 1. Vertical Cabinet (Sheet 1 of 2)

KSC-SPEC-E-0002
 March 15, 1967
 Supersedes KSC-E-153
 January 21, 1964

PANEL WIDTH	DIMENSIONS								
	A	B	C	D	E±.046	F±.046	G	H±.046	J
19.00	17.69	17.81	18.31	19.06	21.06	25.50	78.88	86.25	16.25
						30.56	78.88	86.25	
						25.50	77.13	84.50	
						30.56	77.13	84.50	
						25.50	70.13	77.50	
						30.56	70.13	77.50	
						25.50	52.63	60.00	
19.00	17.69	17.81	18.31	19.06	21.06	30.56	52.63	60.00	16.25
24.00	22.69	22.81	23.31	24.06	26.06	25.50	78.88	86.25	21.25
						30.56	78.88	86.25	
						25.50	77.13	84.50	
						30.56	77.13	84.50	
						25.50	70.13	77.50	
						30.56	70.13	77.50	
						25.50	52.63	60.00	
24.00	22.69	22.81	23.31	24.06		30.56	52.63	60.00	
19.00	17.69	17.81	18.31	19.06		25.50	78.88	86.25	
						30.56	78.88	86.25	
						25.50	77.13	84.50	
						30.56	77.13	84.50	
						25.50	70.13	77.50	
						30.56	70.13	77.50	
						25.50	52.63	60.00	
19.00	17.69	17.81	18.31	19.06	26.06	30.56	52.63	60.00	21.25

Figure 1. Vertical Cabinet (Sheet 2 of 2)

KSC-SPEC-E-0002
 March 15, 1967
 Supersedes KSC-E-153
 January 21, 1964

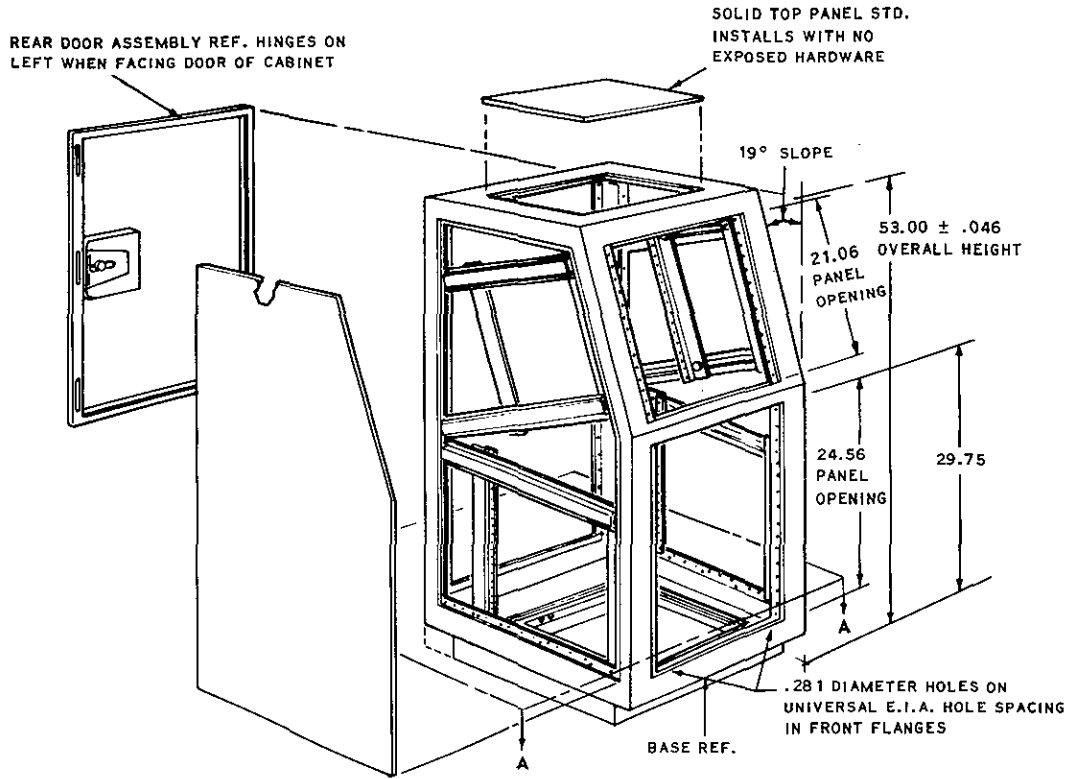

SECTION A-A

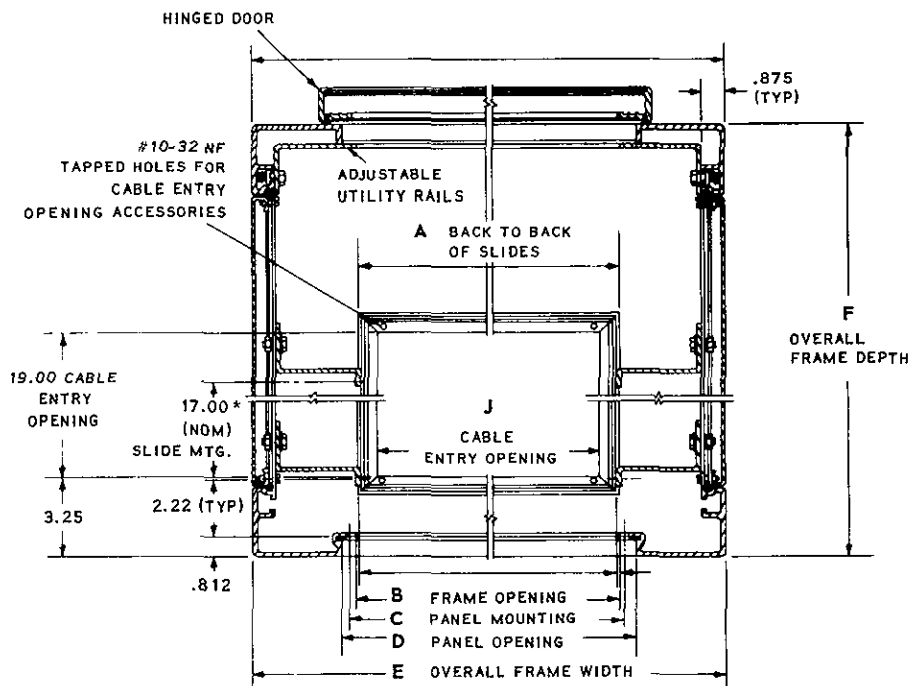

*UNIVERSALLY ADJUSTABLE

Figure 2. Slope Front Console (Sheet 1 of 2)

KSC-SPEC-E-0002
March 15, 1967
Supersedes KSC-E-153
January 21, 1964

PANEL WIDTH	DIMENSIONS						
	A	B	C	D	E±.046	F±.046	J
19.00	17.687	17.812	18.312	19.062	26.06	25.500	16.25
19.00	17.687	17.812	18.312	19.062	26.06	30.562	16.25
24.00	22.687	22.812	23.312	24.062	26.06	25.500	21.25
24.00	22.687	22.812	23.312	24.062	26.06	30.562	21.25
19.00	17.687	17.812	18.312	19.062	21.06	25.500	16.25
19.00	17.687	17.812	18.312	19.062	21.06	30.562	16.25

Figure 2. Slope Front Console (Sheet 2 of 2)

KSC-SPEC-E-0002
 March 15, 1967
 Supersedes KSC-E-153
 January 21, 1964

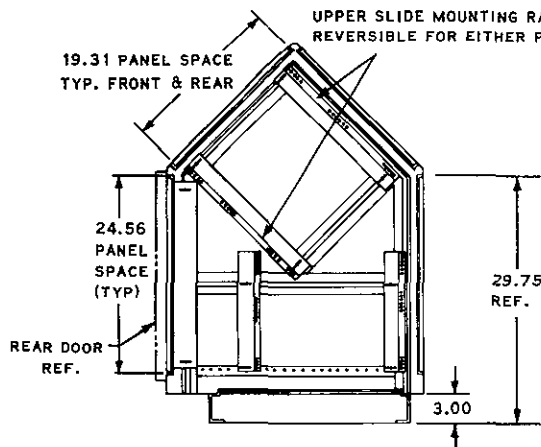
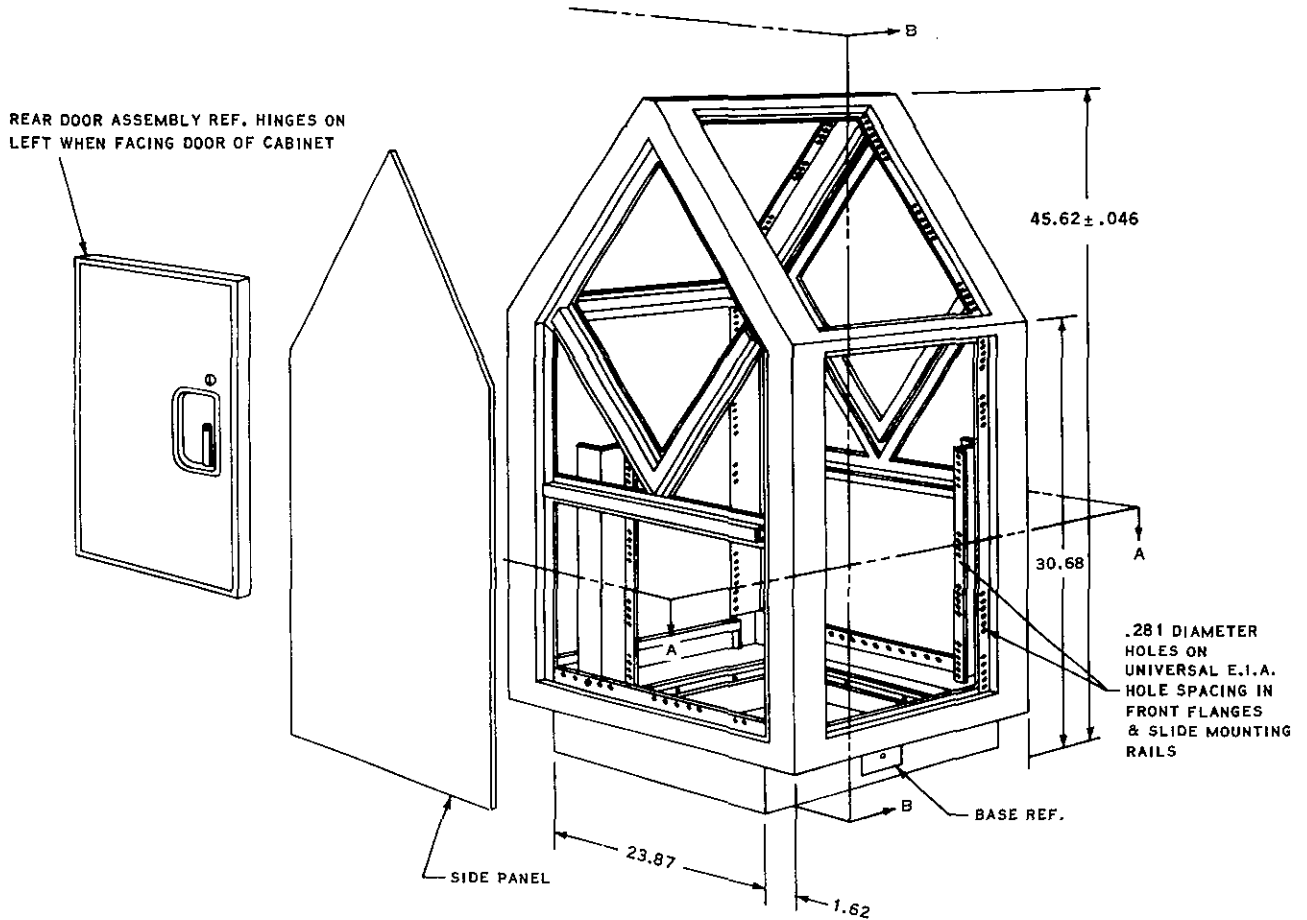

SECTION B-B

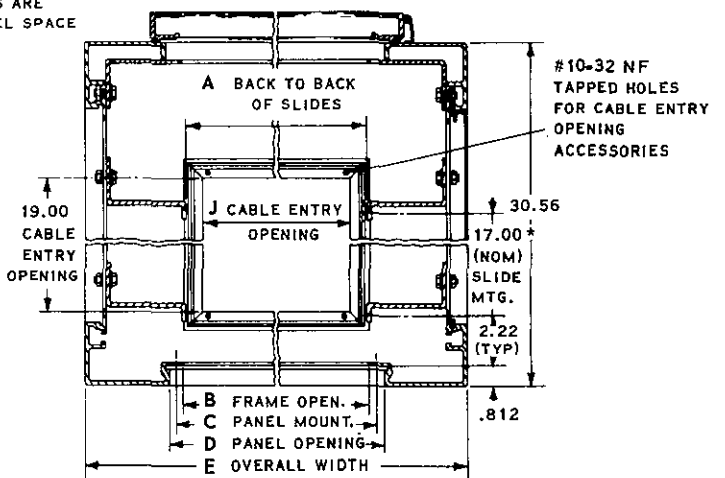

SECTION A-A

*UNIVERSALLY ADJUSTABLE

Figure 3. Low Silhouette Console (Sheet 1 of 2)

KSC-SPEC-E-0002
March 15, 1967
Supersedes KSC-E-153
January 21, 1964

PANEL WIDTH	DIMENSIONS					
	A	B	C	D	E±.046	J
19.00	17.687	17.812	18.312	19.062	26.06	16.25
24.00	22.687	22.812	23.312	24.062	26.06	21.25
19.00	17.687	17.812	18.312	19.062	21.06	16.25

Figure 3. Low Silhouette Console (Sheet 2 of 2)

KSC-SPEC-E-0002
 March 15, 1967
 Supersedes KSC-E-153
 January 21, 1964

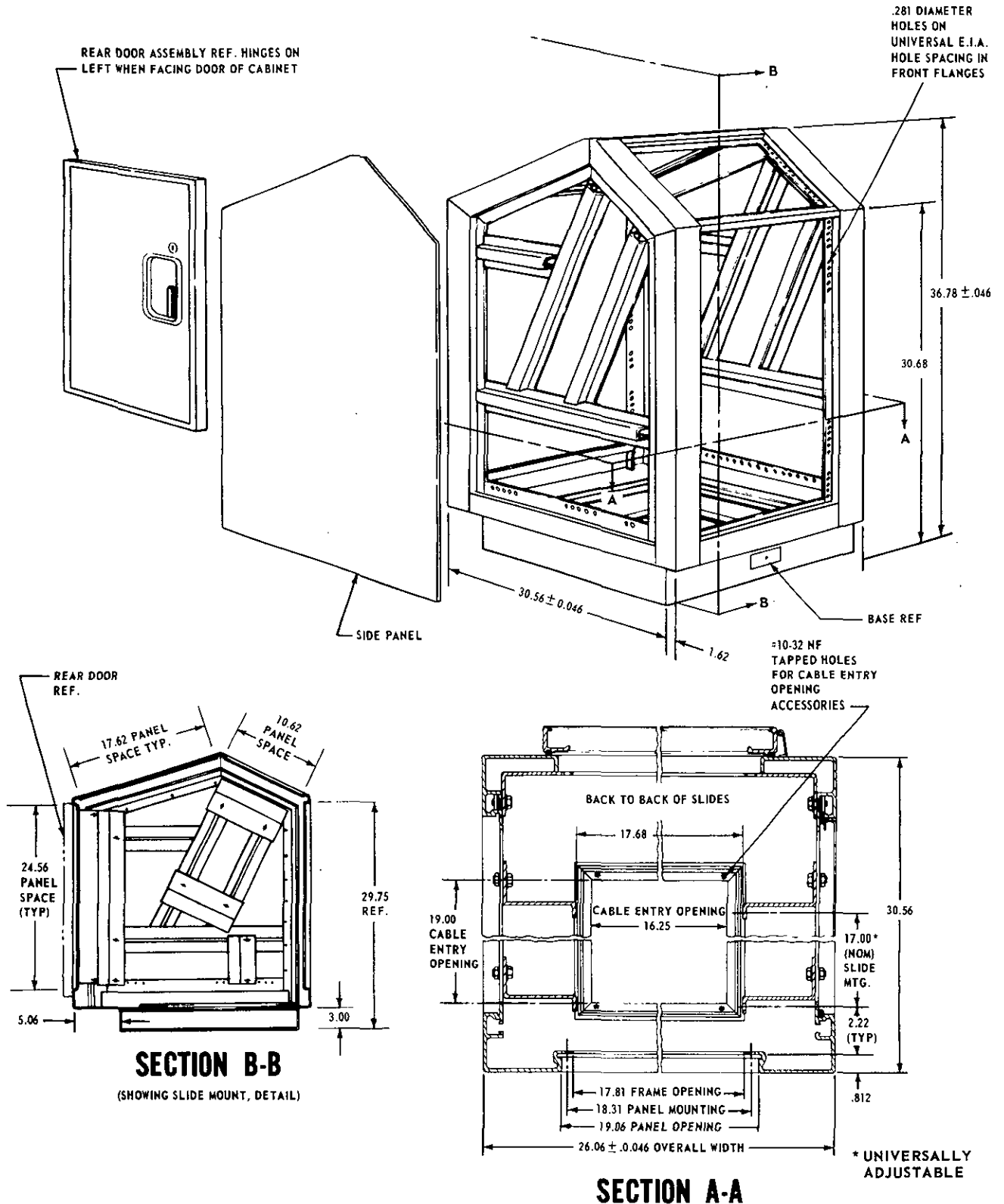

Figure 4. Test Director Special Console

KSC-SPEC-E-0002
 March 15, 1967
 Supersedes KSC-E-153
 January 21, 1967

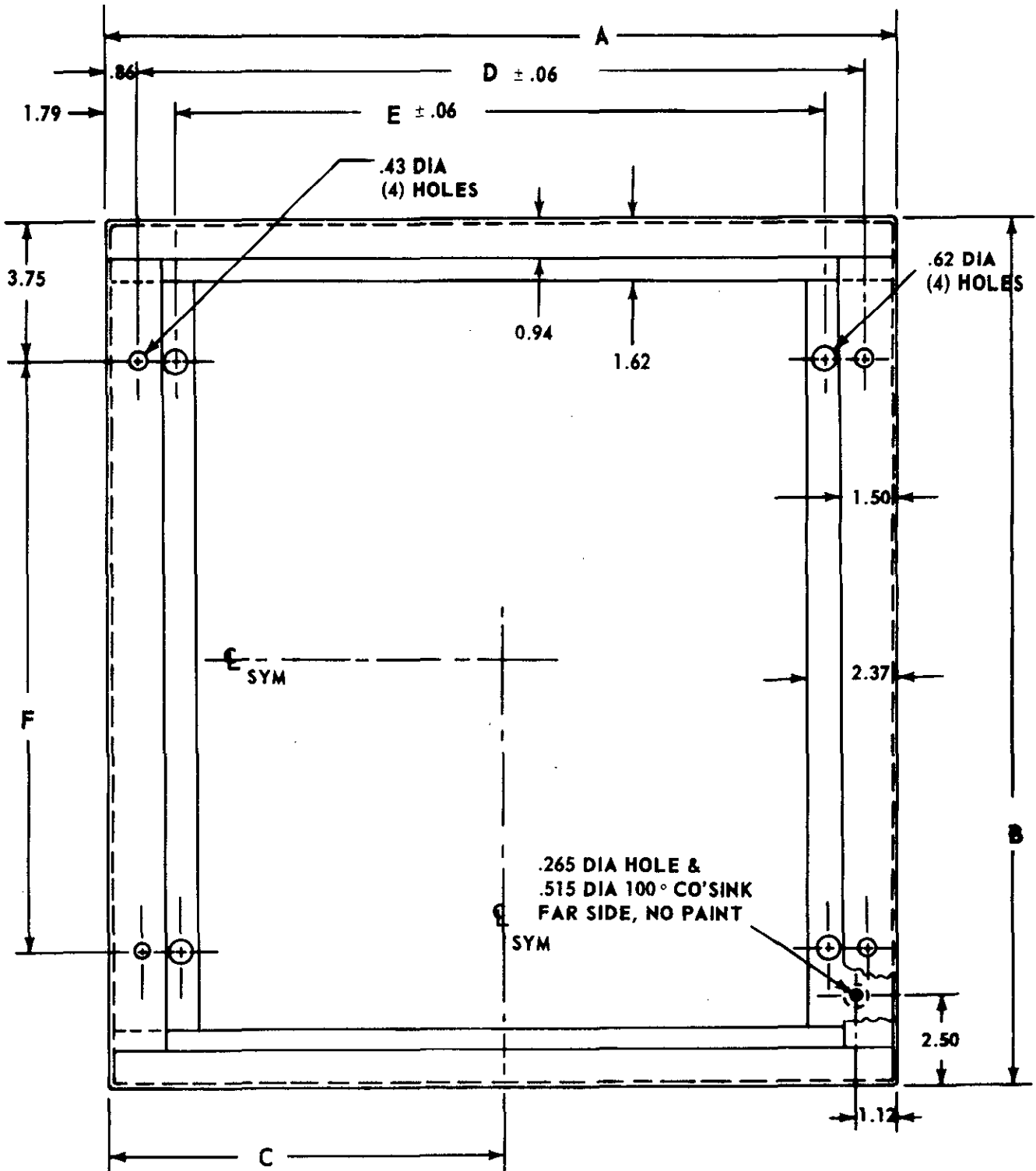

Figure 5. Base (Sheet 1 of 2)

KSC-SPEC-E-0002
 March 15, 1967
 Supersedes KSC-E-153
 January 21, 1964

A	B	C	D	E	F
21.03	23.87	10.53	19.31	17.44	16.37
26.03	23.87	13.03	24.31	22.44	16.37
21.03	37.06	10.53	19.31	17.44	29.56

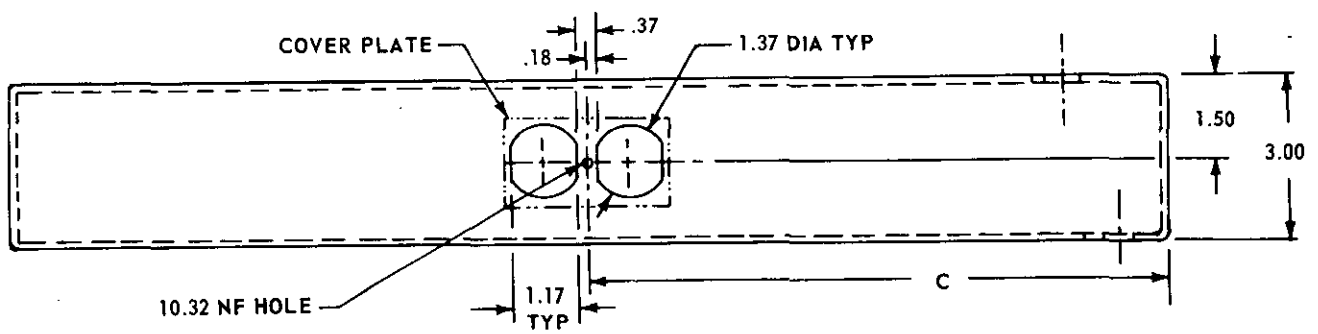
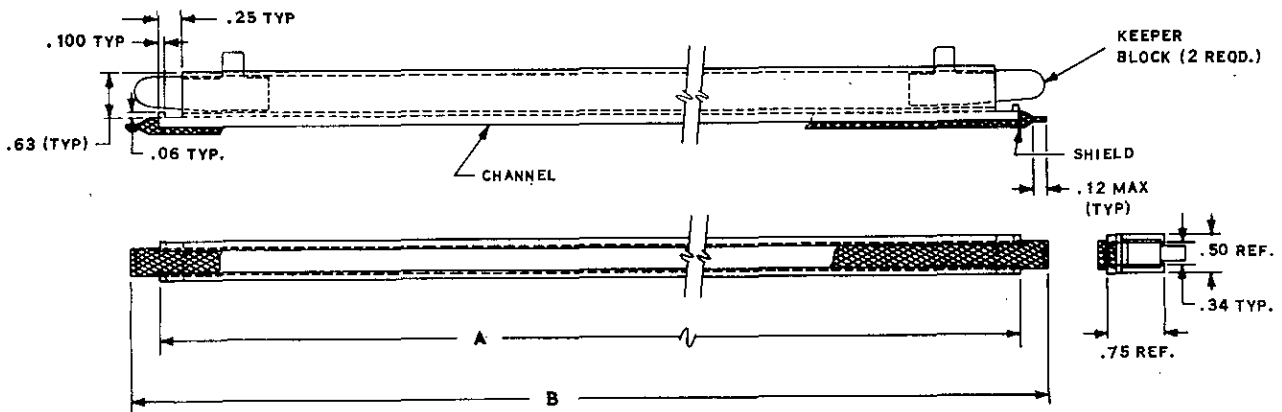
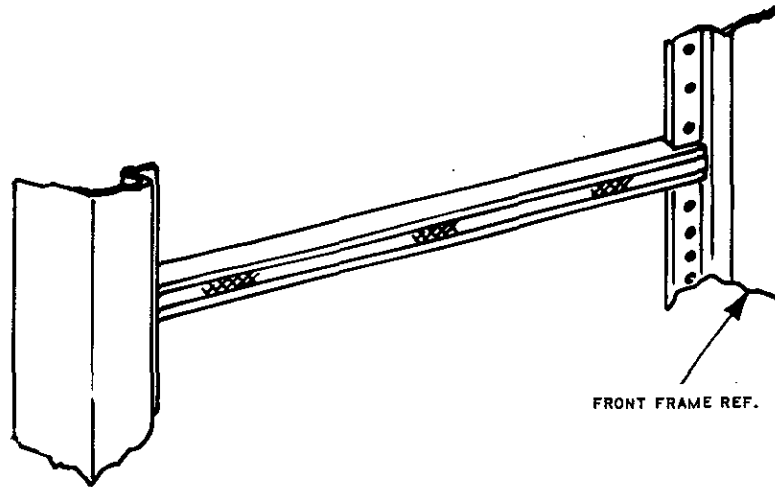

Figure 5. Base (Sheet 2 of 2)

KSC-SPEC-E-0002
 March 15, 1967
 Supersedes KSC-E-153
 January 21, 1964



PANEL SIZE	DIM A	DIM B
19.00	18.28	19.00
24.00	23.28	24.00

Figure 6. Intermediate Bar

KSC-SPEC-E-0002
 March 15, 1967
 Supersedes KSC-E-153
 January 21, 1964

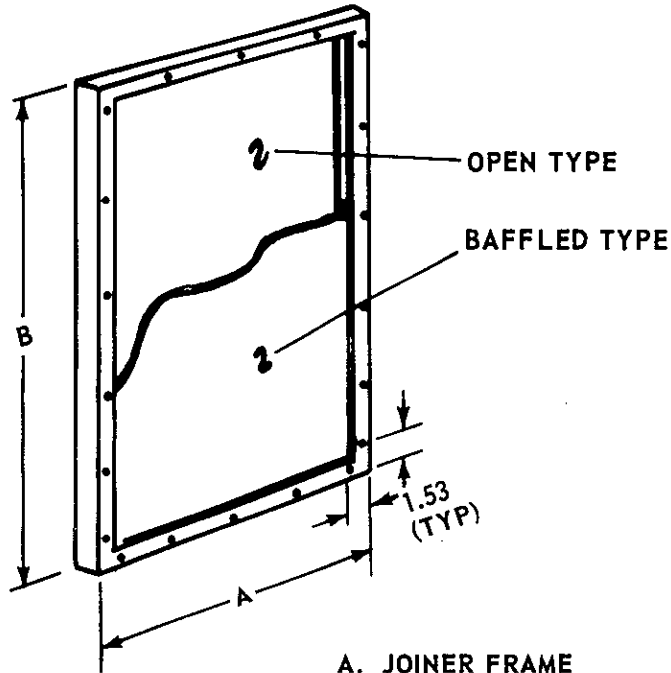

A. JOINER FRAME
 (VERTICAL CABINET)

A	
DIM A	DIM B
24.94	78.75
24.94	52.50
B	
DIM A	DIM B
19.88	12.80
24.94	17.87

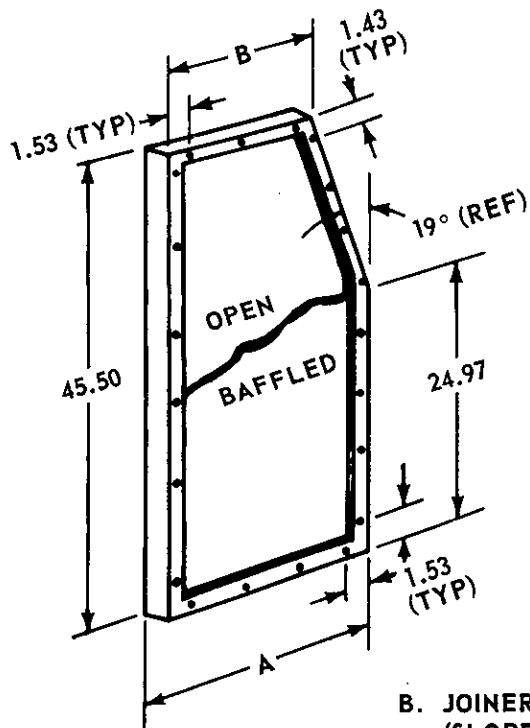

B. JOINER FRAME
 (SLOPE FRONT CONSOLE)

Figure 7. Joiner Frames and Lifting Eyes (Sheet 1 of 2)

KSC-SPEC-E-0002
March 15, 1967
Supersedes KSC-E-153
January 21, 1964

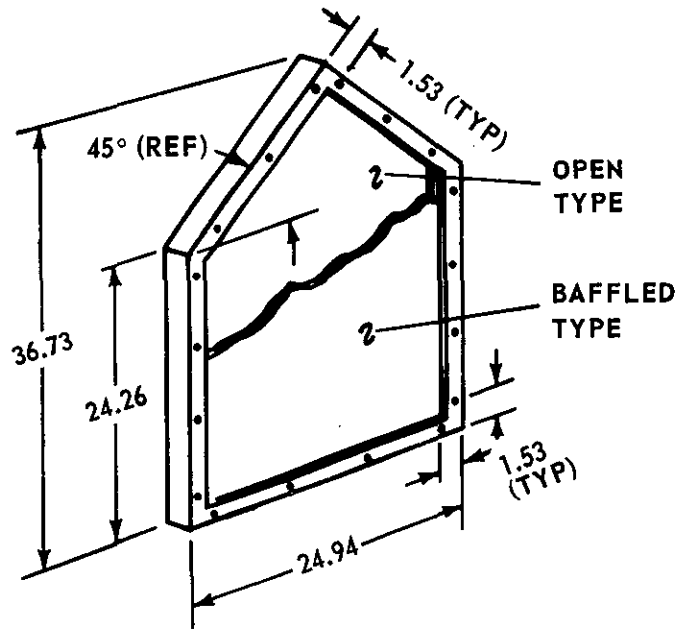

C. JOINER FRAME
(LOW SILHOUETTE
CONSOLE)

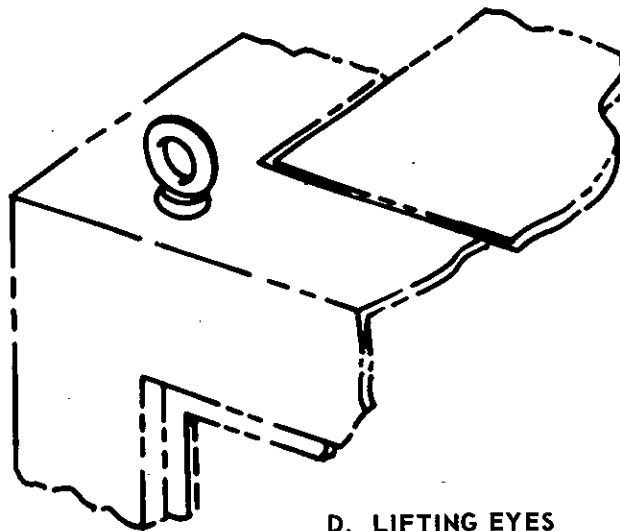

D. LIFTING EYES
(TYP 4 CORNERS)

Figure 7. Joiner Frames and Lifting Eyes (Sheet 2 of 2)

KSC-SPEC-E-0002
March 15, 1967
Supersedes KSC-E-153
January 21, 1964

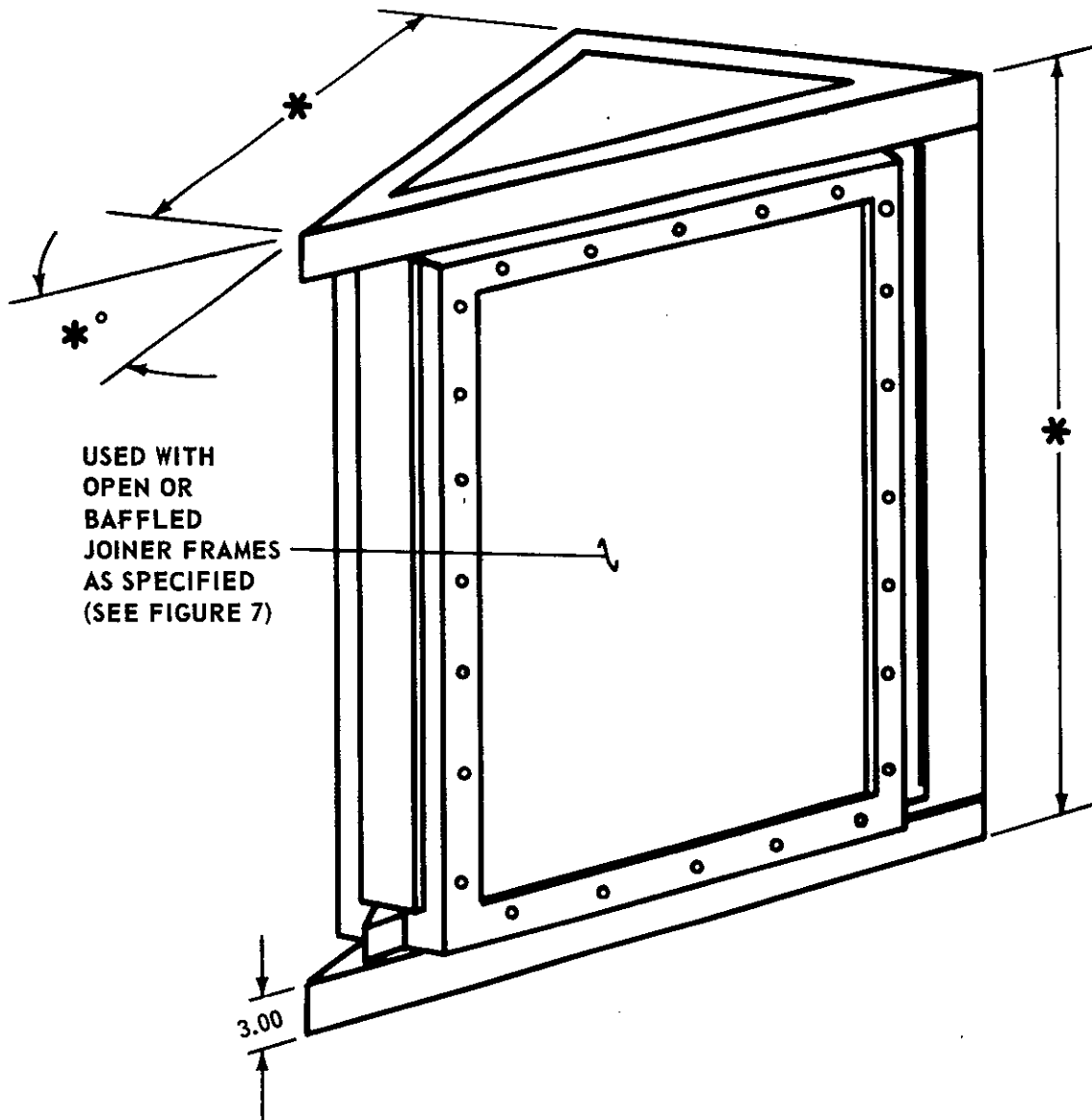

Figure 8. Corner Angle Joiner Units (Sheet 1 of 2)

KSC-SPEC-E-0002
March 15, 1967
Supersedes KSC-E-153
January 21, 1964

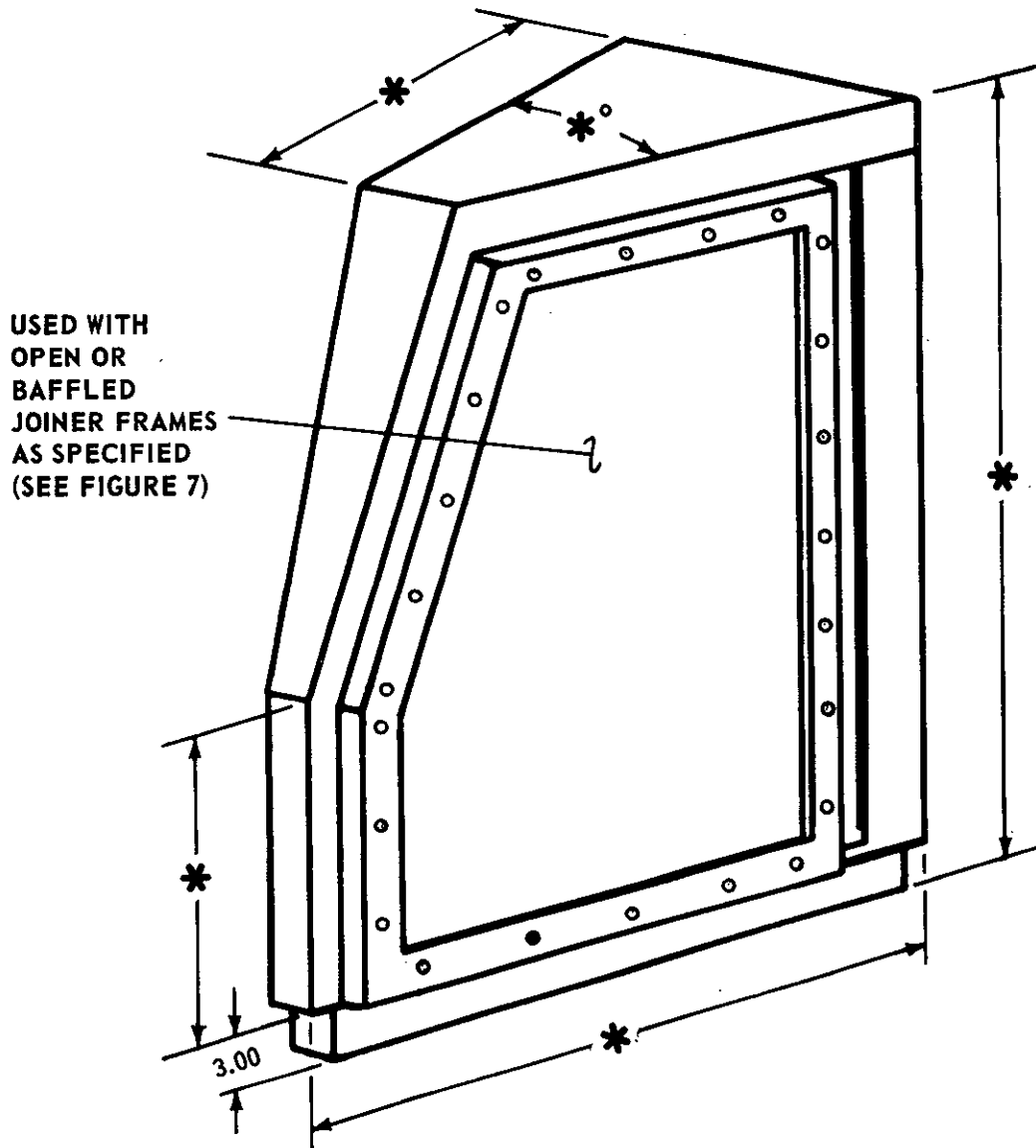
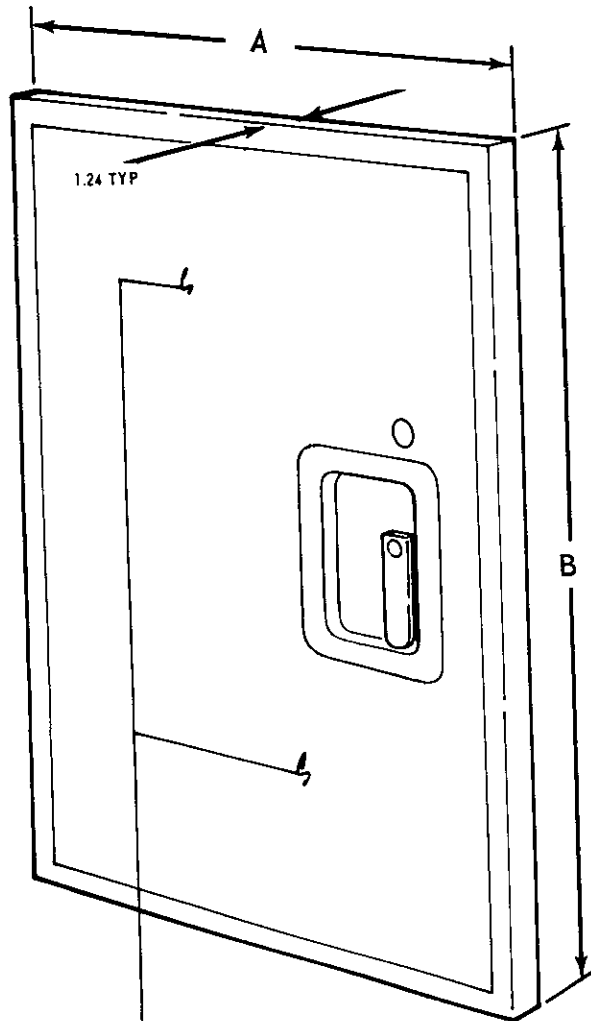

Figure 8. Corner Angle Joiner Units (Sheet 2 of 2)

KSC-SPEC-E-0002
 March 15, 1967
 Supersedes KSC-E-153
 January 21, 1964



* VENTING OF DOOR, TOP AND BOTTOM, MAY BE REQUIRED. VENTED AREA TO BE RFI TIGHT AND OF SUFFICIENT AREA FOR REQUIRED VENTING.

PANEL OPENING (WIDTH)	DIM A
19.06	20.50
24.06	25.50
PANEL OPENING (HEIGHT)	DIM B
78.88	80.37
77.13	78.37
70.13	71.63
52.63	54.13
45.62	47.13
24.56	26.06

Figure 9. Hinged Door (Solid or Vented) (Sheet 1 of 3)

KSC-SPEC-E-0002
March 15, 1967
Supersedes KSC-E-153
January 21, 1964

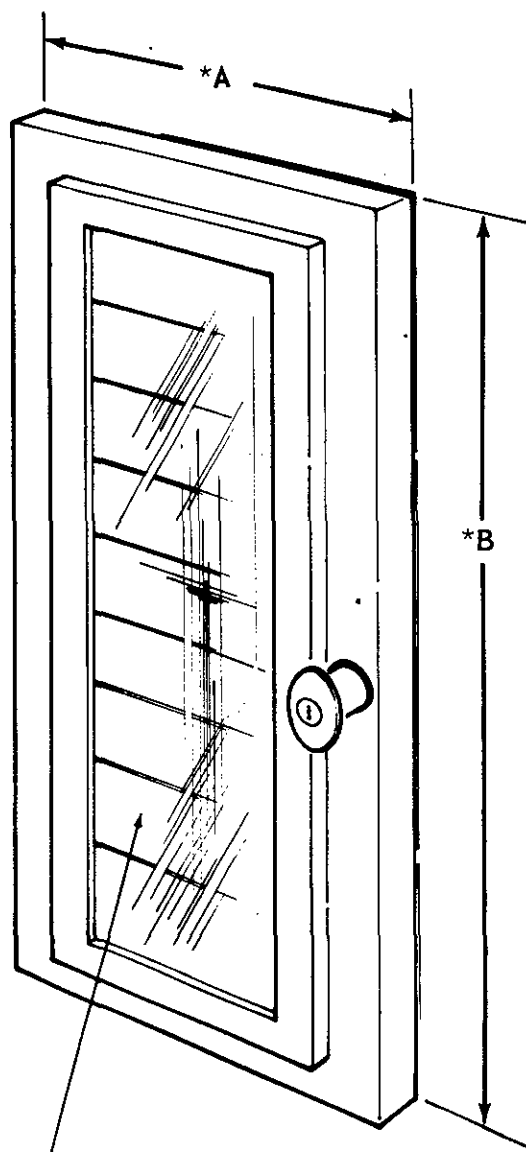

PLEXIGLAS PANEL (PLAIN OR RFI SHIELDED),
3/16 IN. MINIMUM THICKNESS, REQUIRED AS
SPECIFIED BY THE PROCURING ACTIVITY

* AS TABULATED
ON SHEET 1

Figure 9. Hinged Door (Transparent) (Sheet 2 of 3)

KSC-SPEC-E-0002
March 15, 1967
Supersedes KSC-E-153
January 21, 1964

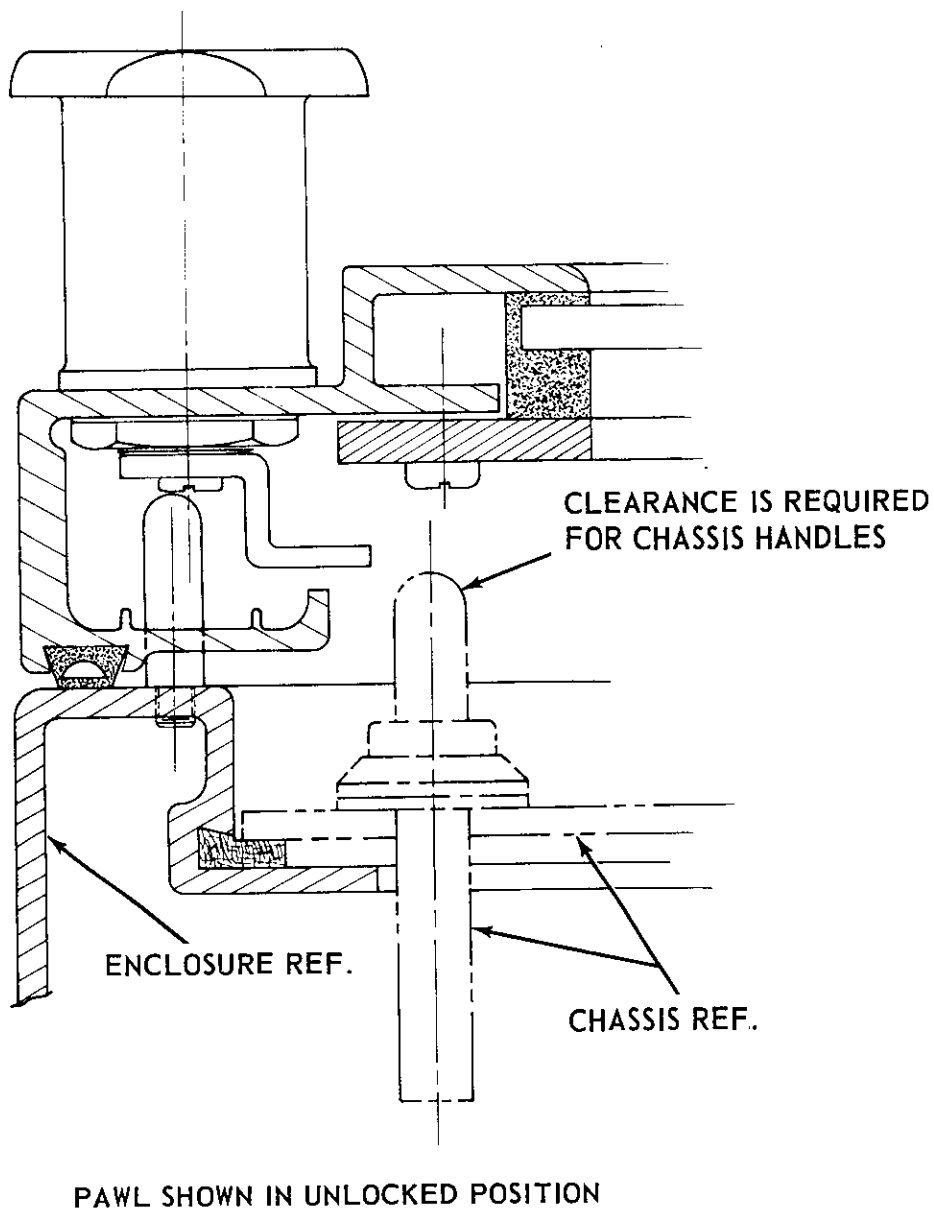
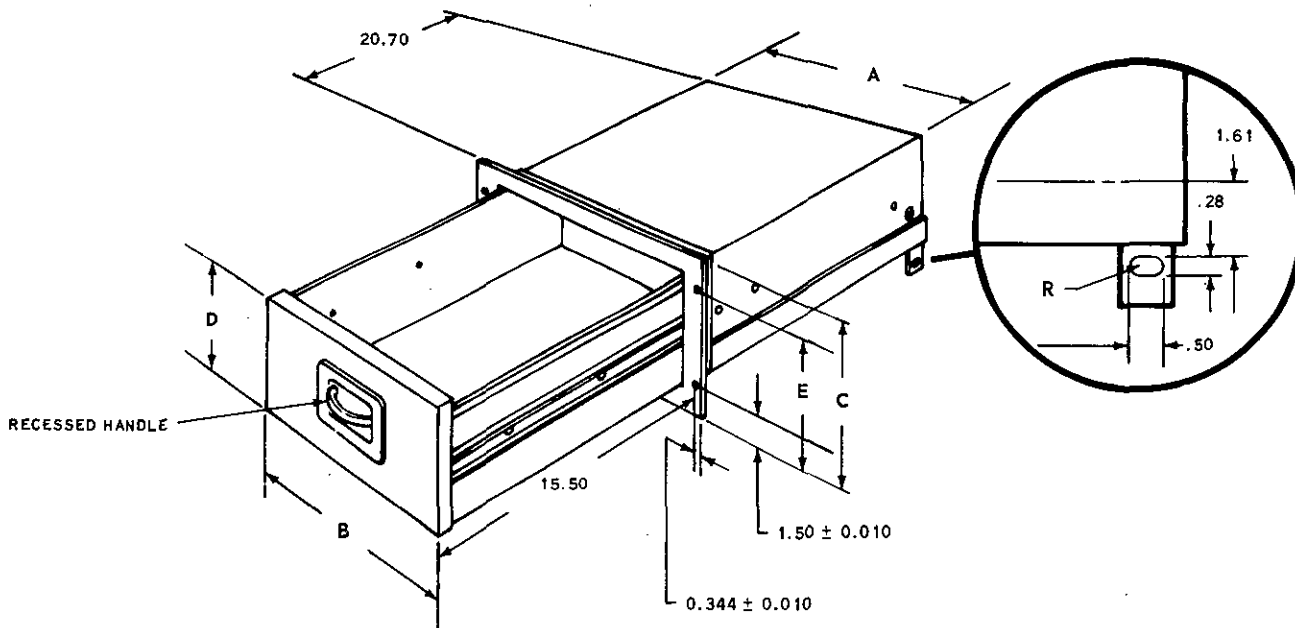

Figure 9. Hinged Door (Transparent; Detail) (Sheet 3 of 3)

KSC-SPEC-E-0002
 March 15, 1967
 Supersedes KSC-E-153
 January 21, 1964



MOUNTS TO STANDARD UNIVERSAL E.I.A. PANEL MOUNTING HOLES

PANEL SIZE	A	B	C	D (approx)	E
19.00	17.62	17.31	7.00	6.50	5.50
24.00	22.62	22.31	7.00	6.50	5.50
19.00	17.62	17.31	10.50	9.50	9.00
24.00	22.62	22.31	10.50	9.50	9.00

Figure 10. Panel Mounted Utility Drawer (RFI Tight)

KSC-SPEC-E-0002
 March 15, 1967
 Supersedes KSC-E-153
 January 21, 1964

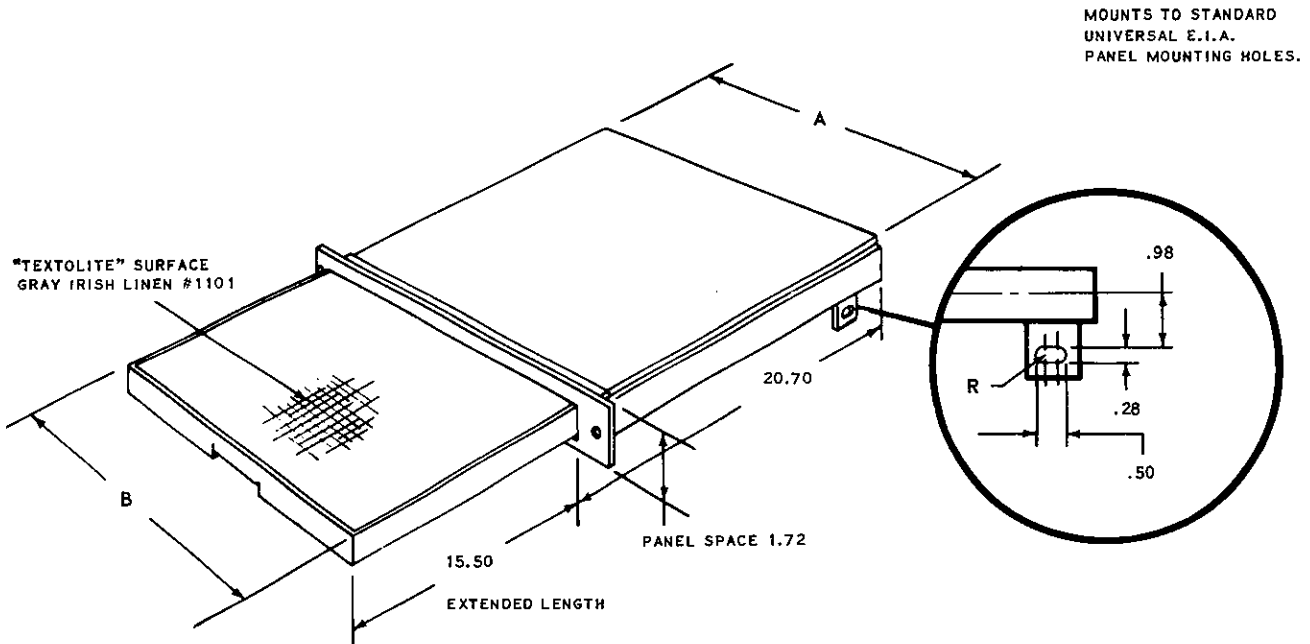

PANEL SIZE	A	B
19.00	17.62	17.31
24.00	22.62	22.31

Figure 11. Retractable Writing Surface (RFI Tight)

KSC-SPEC-E-0002
March 15, 1967
Supersedes KSC-E-153
January 21, 1964

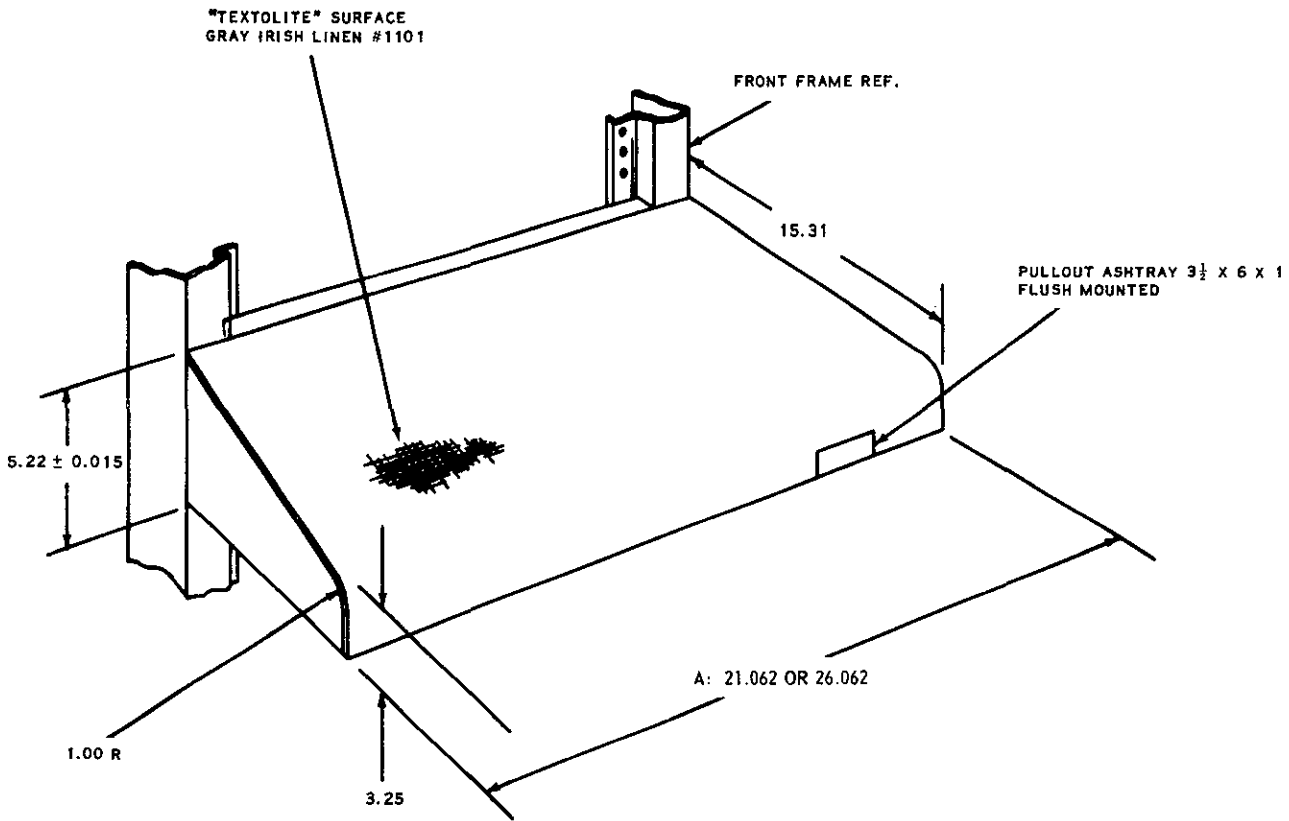

NOTE: WRITING SHELF SHOWN IS STANDARD SINGLE-BAY TYPE. MULTIPLE-BAY UNITS OR OTHER SPECIAL CONFIGURATIONS SHALL BE AS SPECIFIED IN THE CONTRACT.

Figure 12. Panel-Mounted Writing Surface

KSC-SPEC-E-0002
March 15, 1967
Supersedes KSC-E-153
January 21, 1964

3.8 Welding. - Welds shall meet all Class A requirements of MIL-W-6858.

3.9 Frame Structure Rigidity. - Each vertical cabinet frame structure shall be subjected to the following concentrated load test procedure:

- (a) Support the frame structure (panels not installed) of the specimen as shown in figure 13.
- (b) Apply a concentrated 275-pound load at a point that will impose maximum stress on the frame structure.
- (c) Remove load and set frame structure upright. Make distortion measurements; distortion at any point shall not exceed 0.0312 inch. Examine the structure; there shall be no metal fractures.

3.10 Interior Distributed Load. - Each enclosure frame structure shall be subjected to the following interior distributed load test procedure:

- (a) With enclosure sitting upright on a flat horizontal surface (all panels removed) distribute a 1000-pound load evenly inside the enclosure.
- (b) Remove the load. Make distortion measurements; distortion at any point shall not exceed 0.0312 inch. Examine the structure; there shall be no metal fractures.

3.11 Fastening Devices Installation. - Fastening devices shall be installed in accordance with the applicable provisions of MSFC-STD-156.

3.12 Door Options. - Enclosures of all listed types may be procured both with or without front and/or rear doors. Requirements for door venting or transparent doors shall be as specified by the contract.

3.12.1 Utility Rails. - Figures 1 through 4 show enclosure with provision for rear door installation. This requires front-to-back adjustable "utility" rails at rear of enclosure. On the two-door option, these rails will be required at front and rear of enclosure; on the no-door option, utility rails are not required.

3.12.2 Door Handle. - Door handles for solid and vented doors shall be configured and recessed as shown on sheet 1 of figure 9; for the transparent door, as shown on sheets 2 and 3.

KSC-SPEC-E-0002
March 15, 1967
Supersedes KSC-E-153
January 21, 1964

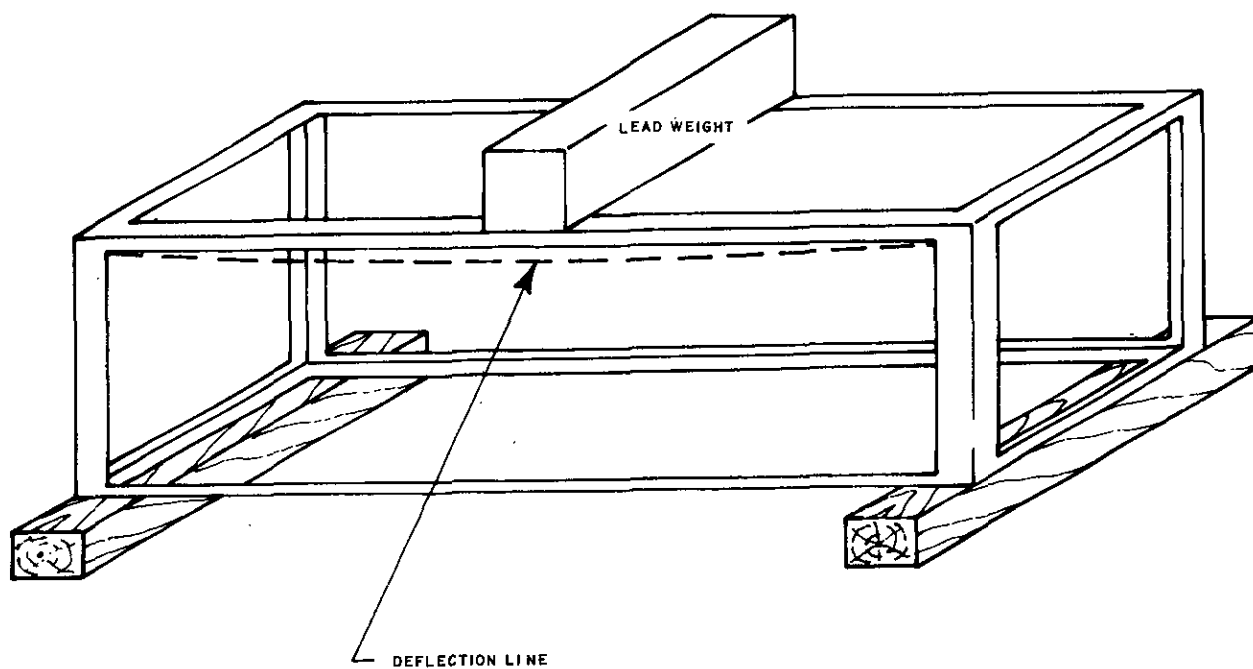

Figure 13. Exterior Load Test Setup

KSC-SPEC-E-0002
March 15, 1967
Supersedes KSC-E-153
January 21, 1964

3.12.3 Door Hinges. - Hinges shall be liftoff pin type permitting door to be lifted up and off without removal of pins or other attaching hardware.

3.13 Lifting Eyes. - Provision shall be made for installation of removable lifting eyes on the vertical cabinet type of enclosure only (figure 7).

3.14 Finish. - Exterior surfaces of enclosures and accessories, except writing surfaces, shall be painted as follows:

3.14.1 Cleaning and Pretreatment. - Cleaning and pretreatment for painting shall be in accordance with the applicable process for the particular metal(s) as specified in MIL-STD-171.

3.14.2 Painting. - Finish number 21.3 of MIL-STD-171 shall be used. Paint color shall be number 26251, FED-STD-595. Painting procedures shall conform to paragraphs 5.2.1 (baking is optional), 5.2.2, and 5.2.3 of MIL-STD-171.

3.14.3 Writing Surfaces. - Writing surfaces shall be Textolite Surface, Gray Irish Linen, number 1101.

3.15 Component Identification. - Components shall be identified in accordance with MIL-STD-130.

3.16 Component Interchangeability. - All components bearing the same part number shall be interchangeable, without rework or force fit, within any type of enclosure for which designed. Enclosures shall mate, without rework or force fit, with like enclosures for setup in multiple-bay units. Accessories shall mount, without rework or force fit, to any enclosure for which designed.

3.17 Shielding. - All necessary mechanical discontinuities in the enclosure, retractable writing surface, and utility drawer shall be electrically continuous across the interface of the discontinuity so as to provide a low impedance current path.

3.17.1 Ventilating Openings. - Ventilation openings shall permit conformance to the RFI limits specified in Figure 17.

3.17.2 Bonding. - Electrical bonding shall be provided where access doors, panels, plates, mounted accessories, or other separable joints form a part of the shielding. (Hinges in themselves are not considered satisfactory conductive paths.)

KSC-SPEC-E-0002

March 15, 1967

Supersedes KSC-E-153

January 21, 1964

3.17.3 Mating Surfaces. - Mating surfaces of the enclosure and all components, including accessories as applicable, shall be free of insulating finishes to provide a continuous electrical bond, to enable bonding contact to the basic structure during installation, and to provide continuous bonding between enclosures set up in multiple-bay units.

4. QUALITY ASSURANCE PROVISIONS

4.1 General. - NASA Quality Publication NPC 200-3, in its entirety, forms a part of this specification except as it may be amended by contract provisions. The supplier may use his own or any other inspection facilities; either must be approved by the John F. Kennedy Space Center (KSC).

4.2 Sampling. - Samples not meeting the requirements of this specification shall be treated as "Nonconforming Articles" in accordance with paragraph 3-8 of NPC 200-3. Provisions for sampling shall be as follows:

4.2.1 Preproduction. - The contract shall specify if preproduction sampling is required and, if so, the numbers and types of items to be sampled. Such samples shall be representative of the identical materials and production manufacturing processes to be used. Preproduction samples shall be subjected to the inspections and tests prescribed herein.

4.2.2 Quality Assurance. - The Government reserves the right to select a sample(s) at random from any production lot and subject it to all inspections and tests of paragraph 4. Failure of such sample(s) shall require rejection of the sampled lot.

4.3 Acceptance Requirements. - Completed enclosures shall meet the inspection and test requirements of paragraphs 4.4.1, 4.4.2, 4.4.3, and 4.4.9. Additionally, an enclosure that has satisfied acceptance requirements shall be set aside and used for RFI acceptance test, paragraph 4.4.9, of each utility drawer and/or retractable writing shelf produced on order.

4.4 Inspection and Test Requirements. - The supplier's test plan established for contract end items shall include provisions for performing the following inspection and test procedures:

4.4.1 Shielding. - Examine installed shielding material and ensure that it is evenly and securely bonded to the mating surface and that it makes complete and intimate contact with the contacting surface.

KSC-SPEC-E-0002
March 15, 1967
Supersedes KSC-E-153
January 21, 1964

4.4.2 Fit and Interchangeability. - Check that assembly of panels at each location on the enclosure is accomplished easily and without force being required and that mating holes align properly. Check that door(s) assembles to the enclosure such that it moves freely, latches properly without need for undue effort, and bonds evenly and firmly around the periphery. Check door lock for proper action. Make sufficient random selection of enclosures, panels, and accessories for assembly to ensure interchangeability.

4.4.3 Finish. - Visually inspect paint coating for hiding power, gloss, smoothness, and proper color.

4.4.4 Vibration Testing. - Test specimen shall be a production item that has undergone final inspection.

4.4.4.1 Required Equipment. - The following equipment, or equivalent, is required.

- (a) Accelerometer: Endevco Model 2215.
- (b) Amplifier: Endevco Model 2607.
- (c) Test Fixture: As required to secure test specimen to vibration table.
- (d) Vibration Table: Capable of applying sinusoidal vibration to the specimen and test fixture in a logarithmic frequency sweep of 10 to 2000 to 10 cps for time periods specified at following amplitudes.

Vertical

10 to 200 cps at 0.001 inch double amplitude (DA)

200 to 2000 cps at 2.1 g peak

10 to 125 cps at 0.0535 inch DA

10 to 125 cps at 15 g peak

KSC-SPEC-E-0002
March 15, 1967
Supersedes KSC-E-153
January 21, 1964

Transverse Axes

10 to 200 cps at 0.007 inch DA

200 to 2000 cps at 1.4 g peak

4.4.4.2 Vibration Input Control. - Vibration input to the test specimen shall be controlled from an accelerometer securely mounted to the test fixture. Accelerometer shall be located so that it will most nearly reproduce the mean of the vibration induced.

4.4.4.3 Standard Conditions. - The vibration test shall be conducted under the following conditions.

- (a) Temperature: $+77^{\circ} \pm 18^{\circ}\text{F}$
- (b) Relative humidity: 90 percent maximum
- (c) Atmospheric pressure: Local ambient

4.4.4.4 Enclosure Loading. - The assembled enclosure with attached mounting base shall have slides P/N 150798-L-R installed and an available chassis for simulated load mounting. Five hundred pounds of unsymmetrically placed loads shall be installed inside the enclosure. Light loads shall be fixed; heavy loads shall be chassis mounted, one load of which shall be 100 pounds minimum.

4.4.4.5 Operating Procedure. - The following operating procedures shall be observed.

4.4.4.5.1 Resonant Points. - All significant resonant points shall be recorded. At each such point, the specimen shall be subjected to a 1-minute dwell. If more than one significant resonant point occurs along any one axis, divide the test period among those points considered most likely to cause failure. If no significant resonant frequencies are noted, the specimen shall be subjected to a 1-minute dwell at the first resonant frequency below 150 cps; amplitude shall be 0.001 inch DA in the vertical axis; 0.007 inch DA in any transverse axis.

4.4.4.5.2 Test Sequencing. - Test specimen shall be subject to vibration along each of three mutually perpendicular axes: vertical, side to side transverse, and front to back transverse. The specimen shall be mounted to the test fixture, and this assembly shall be mounted to the vibration table as required for input along the specified axis. Sinusoidal vibration input of duration, amplitude, and logarithmic sweep shall be applied as specified

KSC-SPEC-E-0002
March 15, 1967
Supersedes KSC-E-153
January 21, 1964

and, when specified, shall be inspected in accordance with paragraph 4.4.4.5.3, during the following steps.

- (a) Vertical axis: 10 minutes; 10 to 200 to 10 cps; 0.001 DA.
- (b) Inspect.
- (c) Vertical axis: 10 minutes; 200 to 2000 to 200 cps; 2.1 g peak.
- (d) Inspect.
- (e) Side to side transverse axis: 10 minutes; 10 to 200 to 10 cps; 0.007 inch DA.
- (f) Inspect.
- (g) Side to side transverse axis: 10 minutes; 200 to 2000 to 200 cps; 1.4 g peak.
- (h) Inspect.
- (i) Front to back transverse axis: 10 minutes; 10 to 200 to 10 cps; 0.007 inch DA.
- (j) Inspect.
- (k) Front to back transverse axis: 10 minutes; 200 to 2000 to 200 cps; 1.4 g peak.
- (l) Inspect.

4.4.4.5.3 Post-Vibration Inspection. - The following requirements shall be met.

- (a) Check door operation and condition. Door shall operate easily, latch securely, and make intimate peripheral contact with the enclosure. Lock shall function properly.
- (b) Check mounting base. There shall be no fractured parts, loose attachment, evidence of deformation or other damage.

KSC-SPEC-E-0002
March 15, 1967
Supersedes KSC-E-153
January 21, 1964

- (c) Make overall check of enclosure. There shall be no metal fractures; fractured, missing, or loose parts; or other evidence of damage.

4.4.5 Temperature Extremes. - The enclosure shall be subjected to the following tests.

4.4.5.1 Low Temperature. - Install test specimen in environmental chamber. Reduce chamber temperature to 0° F and maintain 0° F for 36 hours. At end of this period, check enclosure. Door shall operate easily and latch securely. There shall be no looseness of attached parts or evidence of damage. Allow chamber temperature to return to ambient and repeat check.

4.4.5.2 High Temperature. - Increase chamber temperature to $+150^{\circ}$ F and maintain $+150^{\circ}$ F for 36 hours. Check enclosure as specified in 4.4.5.1. Allow chamber temperature to return to ambient. Repeat check.

4.4.6 Humidity Tests. - Subject the test specimen to the Humidity Tests, Procedure I, of MIL-E-4970. At the end of the specified 240-hour test period, examine the specimen for corrosion and damage to finish. There shall be no objectionable paint blistering or other damage to finish, rusting, or evidence of electrolytic corrosive action.

4.4.7 Fungus Resistance Tests. - The test specimen shall be subjected to the Fungus Resistance Tests, Procedure I, of MIL-E-4970. At the end of the specified 28-day period, examine the test specimen for evidence of fungus growth; there shall be none.

4.4.8 Salt Fog Tests. - The test specimen shall be subjected to the Salt Fog Tests of MIL-E-4970. At the end of the specified 48-hour period, examine the test specimen for corrosion and damage to finish. There shall be no objectionable paint blistering or other damage to finish, rusting, or evidence of electrolytic corrosive action.

4.4.9 Radio Frequency Interference Shielding Tests. - All production enclosures, utility drawers, and retractable writing surfaces shall be subjected to this test. Tests should be conducted in a shielded enclosed area to lessen ambient interference.

4.4.9.1 Signal Sources. - The following receiver equipments or approved equivalents shall be used.

KSC-SPEC-E-0002
 March 15, 1967
 Supersedes KSC-E-153
 January 21, 1964

- (a) Empire Devices Noise and Field Intensity Meter, NF-105
- (b) Empire Devices Tuning Unit, T-A/105
- (c) Empire Devices Tuning Unit, T-1/105
- (d) Empire Devices Tuning Unit, T-2/105
- (e) Empire Devices Tuning Unit, T-3/105

4.4.9.2 Equipment Combinations. - The required test equipment combinations, or equals, for specified frequency ranges are listed in table 1. Signal source units shall be powered by dry batteries.

Table 1. Test Equipment Combinations			
Frequency (mc)	Signal Source Oscillator	Signal Source Antenna	Receiver Antenna
0.5 to 65	General Radio 1211B	Empire Devices VA-105	Empire Devices VA-105
65 to 400	General Radio 1208B	1/4 wave vertical with counterpoise (figure 14)	Empire Devices DM-105-T2, vert. 1/2 wave dipole
400 to 900	General Radio 1209B	Empire Devices DM-105-T3, horizontal 1/2 wave dipole	Empire Devices DM-105-T3, horizontal 1/2 wave dipole
900 to 1000	General Radio 1218B	Empire Devices DM-105-T3, horizontal 1/2 wave dipole	Empire Devices DM-105-T3, horizontal 1/2 wave dipole

KSC-SPEC-E-0002
March 15, 1967
Supersedes KSC-E-153
January 21, 1964

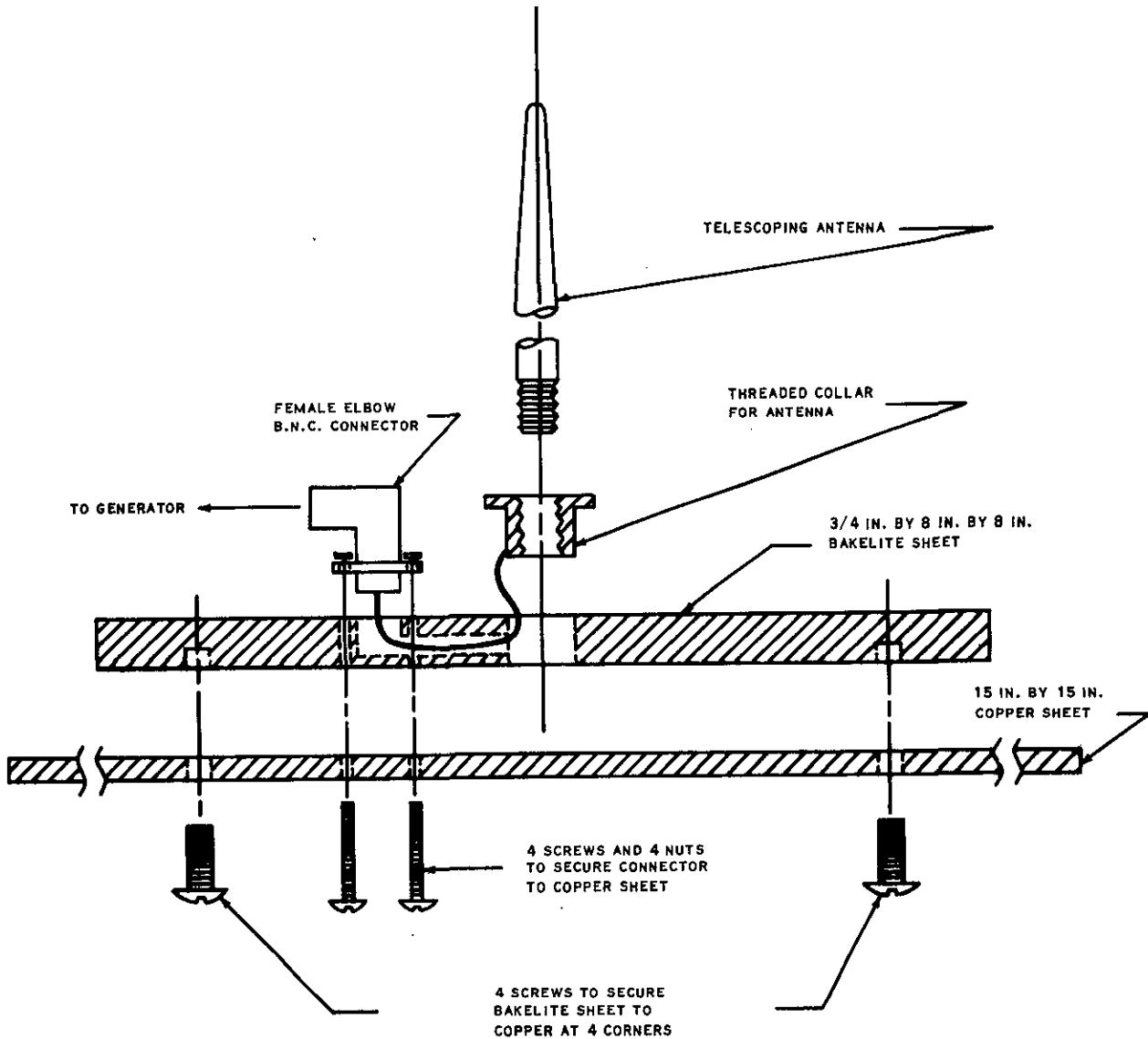

Figure 14. Design Details, 1/4 Wave Vertical Antenna

KSC-SPEC-E-0002
March 15, 1967
Supersedes KSC-E-153
January 21, 1964

4.4.9.3 Operating Procedure. - Attenuation of each enclosure shall be measured at a minimum of two frequencies per octave, or seven frequencies per decade, or every 50 mc, whichever is less, over the frequency range of 0.50 to 1000 mc.

4.4.9.3.1 Enclosure Front Attenuation Measurements. - The following steps shall be performed. (Positioning of units shall be exactly as diagrammed on the referenced figures.)

- (a) Select equipment combination from table 1.
- (b) Place signal source and power supply in enclosure with door open (figure 15). There shall be no power leads external to the enclosure.
- (c) Place signal source antenna in position A (figure 16) and receiver antenna in position C (figure 16).
- (d) Tune signal source to selected frequency. Peak receiver at this frequency and record receiver meter reading.
- (e) Move signal source antenna from position A to position B (figure 16) and close door.
- (f) Peak receiver and record meter reading.
- (g) Record difference between meter readings of steps (d) and (f). Attenuation shall not be less than minimums of figure 17.
- (h) Repeat preceding steps of this paragraph until measurements specified in 4.4.9.3 have been taken.

NOTE

When enclosure attenuation falls below minimums of figure 17, probe enclosure to locate leakage points. Record noted points in the test data record. (Curve of figure 17 is plotted on K+E Semi-Log paper, No. 46 0010, 4 cycles, 70 divisions.)

KSC-SPEC-E-0002
March 15, 1967
Supersedes KSC-E-153
January 21, 1964

4.4.9.3.2 Enclosure Rear Attenuation Measurements. - The following steps shall be performed. (Positioning of units shall be exactly as diagrammed on the referenced figures.)

- (a) Repeat steps (a) and (b) of 4.4.9.3.1.
- (b) Place signal source antenna in position A (figure 18) and receiver antenna in position C (figure 18).
- (c) Tune signal source to selected frequency. Peak receiver at this frequency and record receiver meter reading.
- (d) Move signal source antenna from position A to position B (figure 18) and close door.
- (e) Peak receiver and record meter reading.
- (f) Record difference between meter readings of steps (c) and (e). Attenuation shall not be less than minimums of figure 17.
- (g) Repeat preceding steps of this paragraph until measurements specified in 4.4.9.3 have been taken.

5. PREPARATION FOR DELIVERY

5.1 General. - Preservation, packaging, packing, and marking shall be in accordance with NPC 200-3. Supplier is liable for any damage to units resulting from this phase of his operations.

6. NOTES

6.1 Intended Use. - This specification is intended for use in the procurement of RFI shielded enclosures and related accessories that are compatible with existing installations.

Notice. - When Government drawings, specifications, or other data are used for any purpose other than in connection with a definitely related Government procurement operation, the United States Government thereby incurs no responsibility nor any obligation whatsoever; and the fact that the Government may have formulated, furnished, or in any

KSC-SPEC-E-0002
March 15, 1967
Supersedes KSC-E-153
January 21, 1964

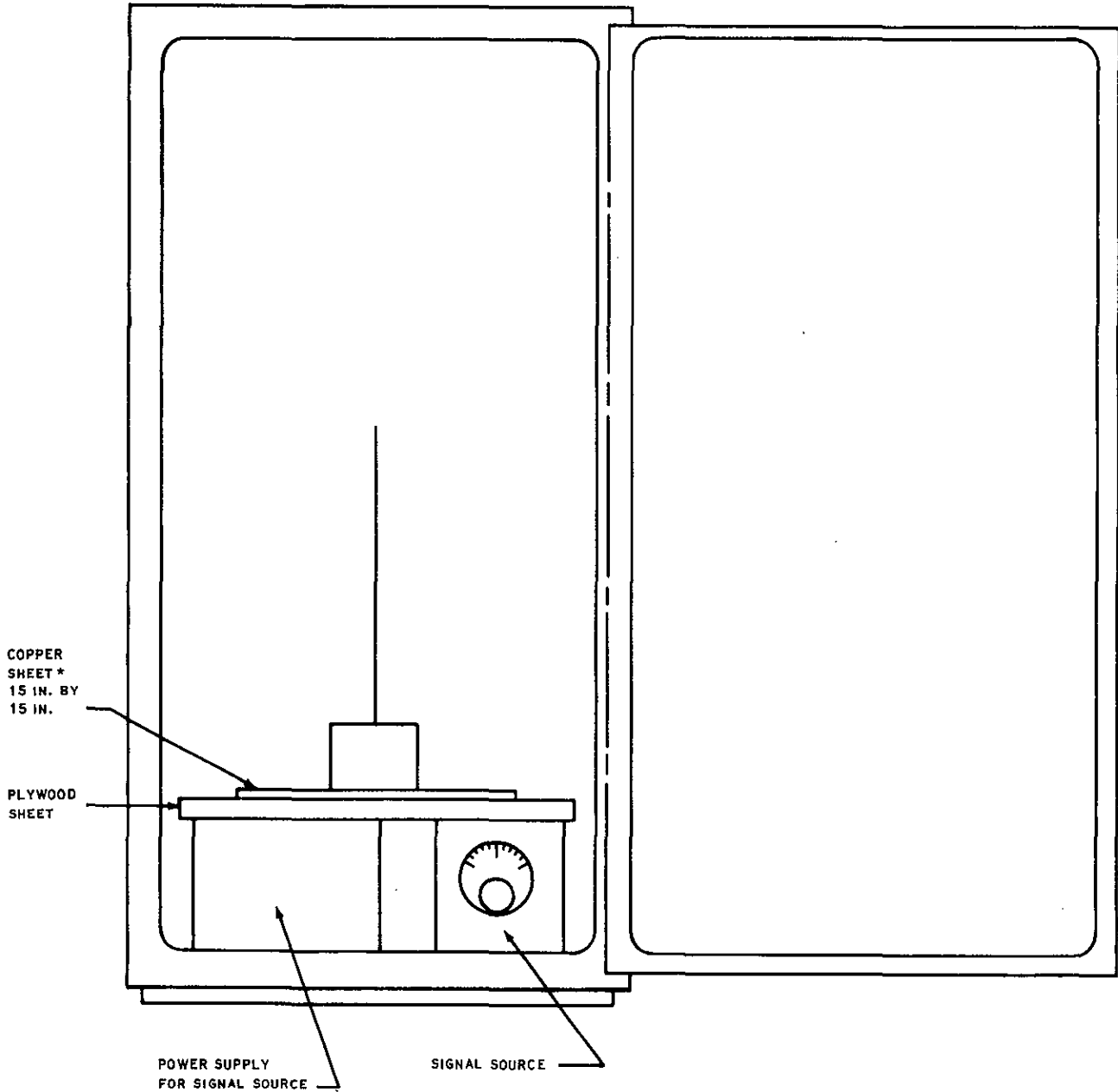

* THE COPPER SHEET SHALL NOT TOUCH THE ENCLOSURE

Figure 15. Signal Source Location

KSC-SPEC-E-0002
March 15, 1967
Supersedes KSC-E-153
January 21, 1964

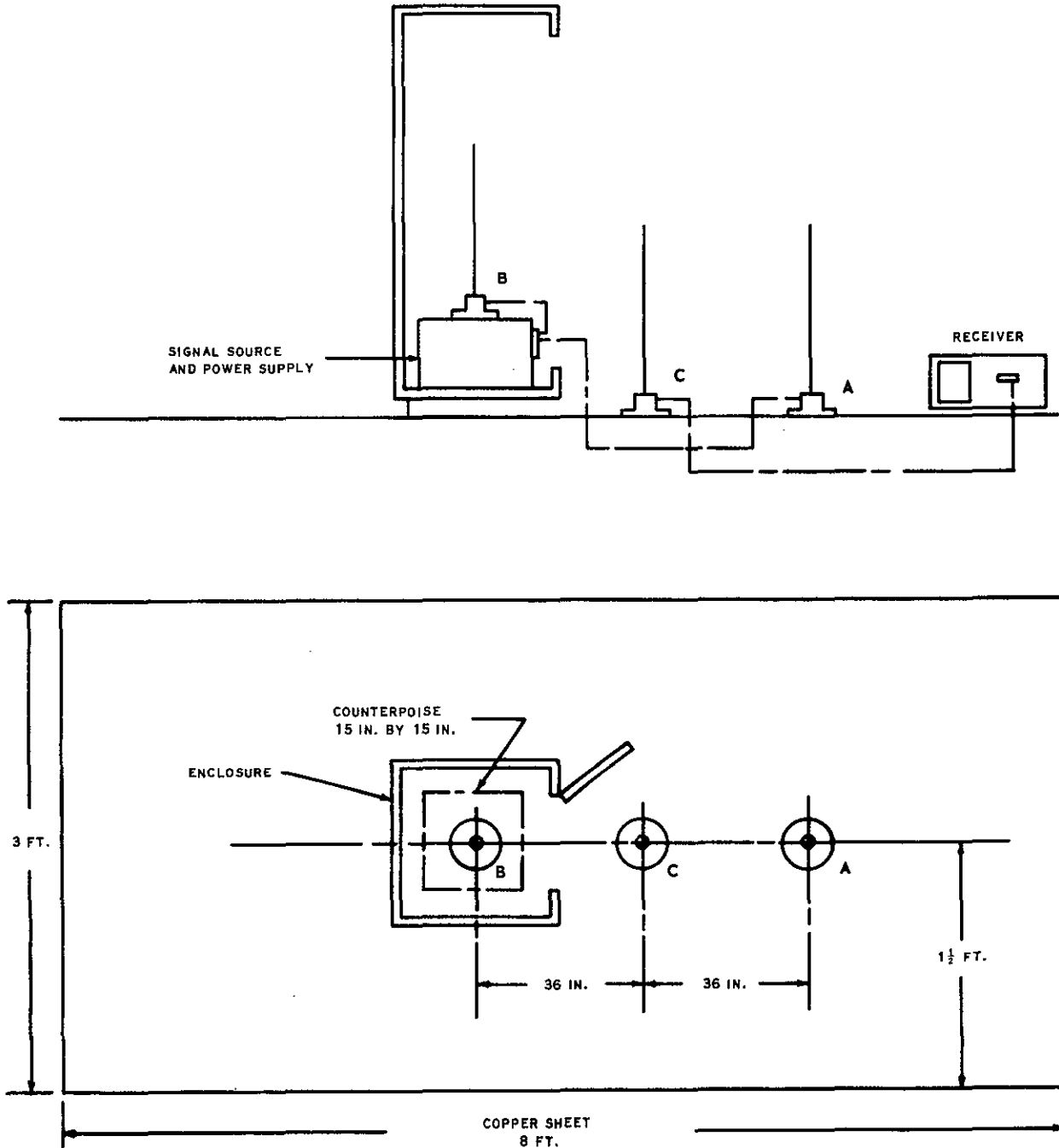

Figure 16. RFI Test Setup (Enclosure Front)

KSC-SPEC-E-0002
March 15, 1967
Supersedes KSC-E-153
January 21, 1964

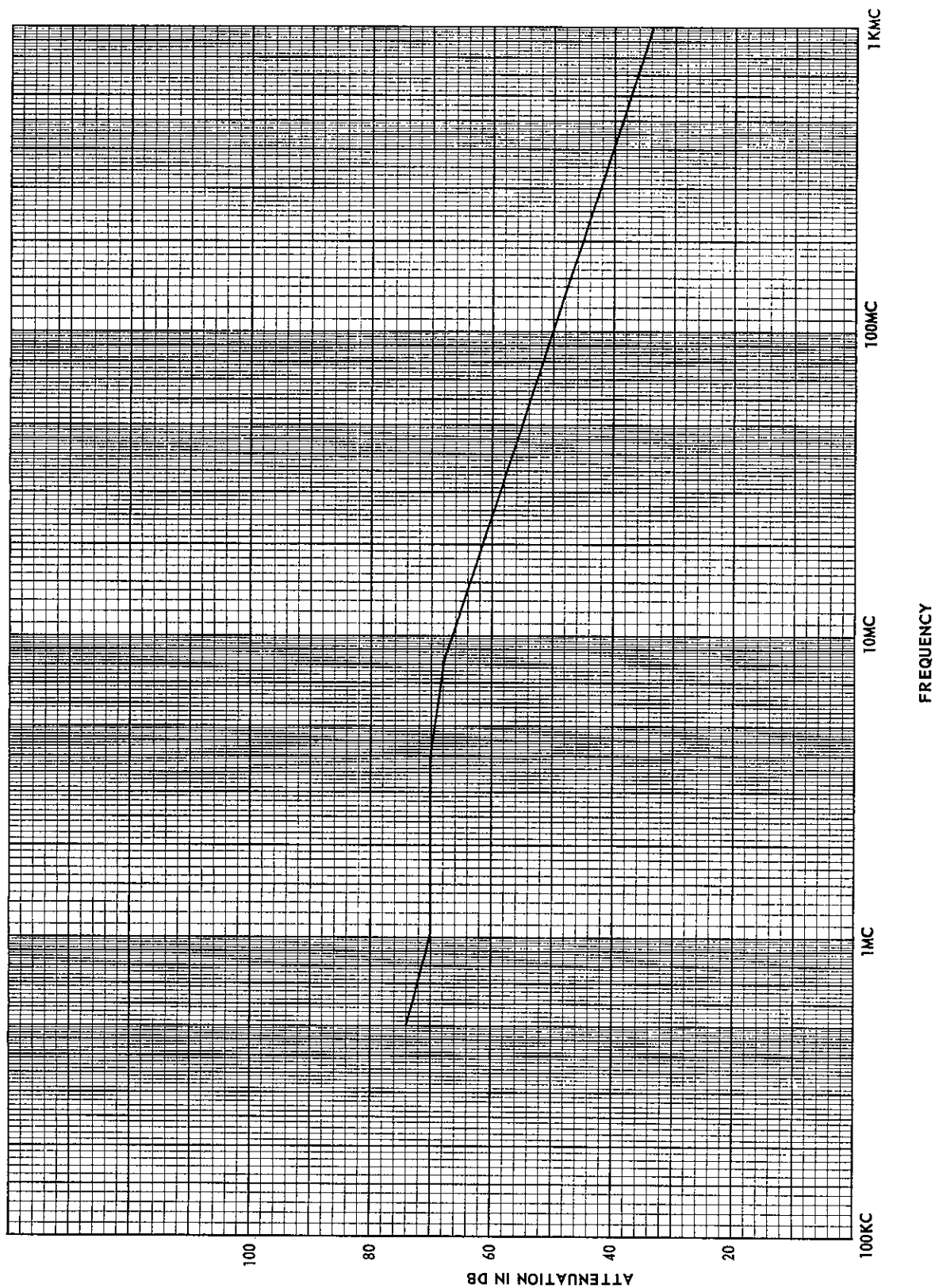

Figure 17. Minimum Attenuation Limits

KSC-SPEC-E-0002
March 15, 1967
Supersedes KSC-E-153
January 21, 1964

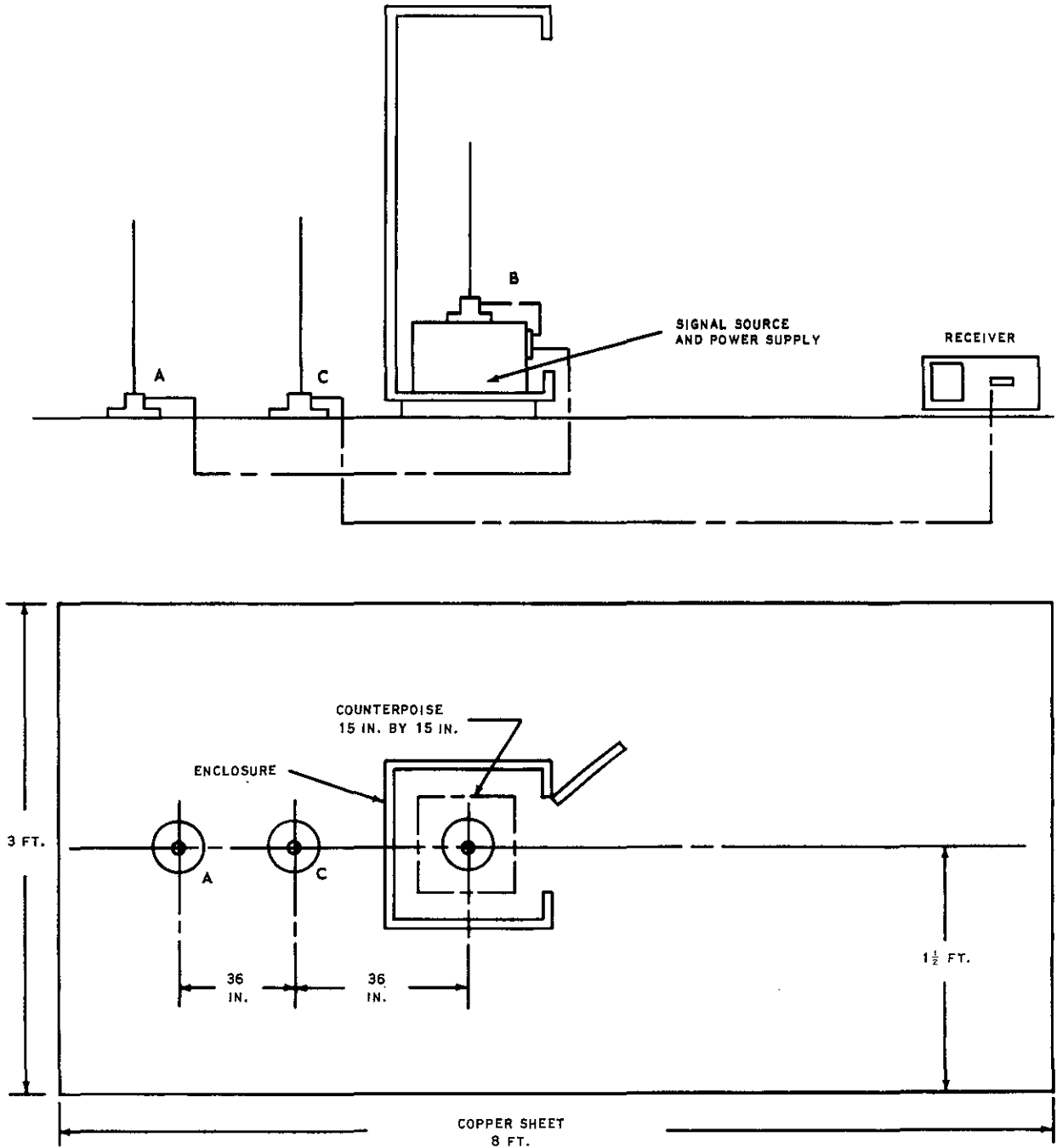

Figure 18. RFI Test Setup (Enclosure Rear)

KSC-SPEC-E-0002
March 15, 1967
Supersedes KSC-E-153
January 21, 1964

way supplied the said drawings, specifications, or other data is not to be regarded by implication or otherwise as in any manner licensing the holder or any other person or corporation or conveying any rights or permission to manufacture, use, or sell any patented invention that may in any way be related thereto.

Custodian:

NASA/John F. Kennedy Space Center

Preparing Activity:

John F. Kennedy Space Center
Electrical-Electronic Systems Division

KSC-SPEC-E-0002
March 15, 1967
Supersedes KSC-E-153
January 21, 1964

DISTRIBUTION

John F. Kennedy Space Center, NASA
Kennedy Space Center, Florida 32899

EA (3)
GD (5)
JB (3)
JC (3)
JG (3)
KC (3)
ME (20)
MJ (3)
PE (3)
QF (2)
RC-424 (36)
RH-141 (3)

George C. Marshall Space Flight Center, NASA
Huntsville, Alabama 35812

NASA Scientific and Technical Information Facility
Post Office Box 33
College Park, Maryland 20740 (2)

TOTAL: 90 Copies