

K-STSM-14.1.14-REVE-O&C
Revision E
November 1994

O&C Building

Payload Processing and

Support Capabilities

RELEASED

CONTRACT NAS10-11400
DRD CA-4

K-STSM-14.1.14
November 1994
Revision E

O&C BUILDING
PAYLOAD PROCESSING AND SUPPORT
CAPABILITIES

Prepared by:

/s/Jeffrey E. Millner
Jeffrey E. Millner
MDS&DS-KSC

Approved by:

/s/P. Thomas Breakfield, III
P. Thomas Breakfield III, CS
Director, Shuttle Flight Operations

/s/Bobby G. Bruckner
Bobby G. Bruckner, CG
Director, Payload Ground Operations

RELEASED

K-STSM-14.1.14
November 1994
Revision E

LIST OF EFFECTIVE PAGES

Revision E supersedes revision D, dated October 1992.

TOTAL NUMBER OF PAGES IN THIS PUBLICATION IS 167.

Page No.

i thru xviii
1-1 thru 1-4
2-1 thru 2-8
3-1 thru 3-44
4-1 thru 4-18
5-1 thru 5-64
6-1 thru 6-4
A-1 thru A-4
B-1 thru B-4

RELEASED

K-STSM-14.1.14

THIS PAGE INTENTIONALLY LEFT BLANK

RELEASED

TABLE OF CONTENTS

<u>Sec/Par</u>	<u>Title</u>	<u>Page</u>
I	INTRODUCTION	1-1
1.1	Purpose	1-1
1.2	Scope	1-1
1.3	Customer Charge	1-1
1.4	Facility Accommodations	1-1
1.5	Hazardous and Controlled Waste	1-1
1.6	Hazardous Substance Inventory	1-3
II	FACILITY DESCRIPTION	2-1
2.1	General	2-1
2.2	Functions	2-3
2.3	Access	2-4
2.3.1	Personnel Access	2-4
2.3.2	Equipment Access	2-4
2.3.3	Wheel Loading Profile	2-4
2.3.3.1	Uniformly Distributed Loads	2-4
2.3.3.2	Wheel Loads	2-4
2.3.3.3	Concentrated Loads	2-5
2.3.4	Emergency Egress	2-5
2.4	Restrictions	2-6
2.5	Operating Regulations	2-6
2.6	Electronic Security System	2-7
2.7	Paging and Area Warning (P&AW)	2-7
III	BAY AREA	3-1
3.1	General	3-1
3.1.1	High Bay	3-1
3.1.2	Low Bay	3-1
3.1.3	Payload Processing Activities	3-5
3.1.4	Environmental Control	3-5
3.1.5	Illumination	3-5
3.1.6	GSE and Services	3-5
3.1.7	Grounding	3-5
3.1.8	Fire Protection and Safety	3-5
3.1.9	Crane and Hoist System	3-8
3.1.10	Air-Bearing Pallet System	3-8
3.1.11	Vent Systems	3-8
3.1.11.1	Experiment Vent System	3-8
3.1.11.2	Vacuum Vent System	3-8
3.1.12	Vacuum Cleaning	3-9
3.1.13	Communications and Data Handling	3-9
3.1.13.1	Operational Intercommunication System (OIS)	3-9
3.1.13.2	Operational Television (OTV)	3-9
3.1.13.3	Telephones	3-9
3.1.13.4	Paging and Area Warning System	3-9
3.1.13.5	Timing	3-9
3.1.13.6	Workstand Bulkhead Interface Assembly	3-9

RELEASED

K-STSM-14.1.14

TABLE OF CONTENTS (Continued)

<u>Sec/Par</u>	<u>Title</u>	<u>Page</u>
3.2	Workstands	3-10
3.2.1	Experiment Integration Stands	3-10
3.2.1.1	South Stand	3-10
3.2.1.2	North Stand.....	3-10
3.2.1.3	Mechanical.....	3-12
3.2.1.4	Electrical	3-15
3.2.1.5	Communications and Data Handling	3-17
3.2.1.6	Electrical GSE (EGSE) Area.....	3-20
3.2.1.7	Mechanical GSE (MGSE) Area.....	3-21
3.2.2	Workstands 2 and 3.....	3-21
3.2.2.1	Mechanical.....	3-21
3.2.2.2	Electrical	3-29
3.2.2.3	Communications and Data Handling	3-30
3.2.3	CITE Stand	3-30
3.2.3.1	Mechanical.....	3-30
3.2.3.2	Electrical	3-33
3.2.3.3	Communications and Data Handling	3-34
3.2.4	Rack, Floor, and Pallet Stand.....	3-35
3.2.4.1	Electrical	3-35
3.2.4.2	Gases	3-35
3.2.5	End Cone Stands.....	3-35
3.3	Other Areas	3-35
3.3.1	Horizontal Sling Kit	3-35
3.3.2	Igloo Work Areas	3-35
3.3.3	Staging and Assembly Areas.....	3-35
3.4	Apollo Telescope Mount Room (ATM) Class 10,000 Clean Work Area	3-37
3.4.1	Description.....	3-37
3.4.2	Access	3-37
3.4.3	Lighting.....	3-37
3.4.4	Vacuum Equipment.....	3-37
3.4.5	Air-Conditioning	3-37
3.4.6	Electrical Power	3-37
3.4.7	Fire Detection	3-40
3.5	Portable Access and Handling GSE.....	3-40
3.5.1	Spacelab GSE	3-40
3.5.2	Access Equipment	3-40
3.6	Vertical Access Simulator (VAS)	3-40
IV	CONTROL AND MONITORING AREAS	4-1
4.1	General.....	4-1
4.2	Experiment Integration Control Rooms.....	4-1
4.2.1	PCU	4-1
4.2.2	HITS.....	4-1
4.3	Spacelab Control Rooms.....	4-4
4.4	CITE Control Room	4-4
4.5	Engineering Support Area (ESA).....	4-9
4.6	High Rate Multiplexer Test Station and CCTV Room (Room 1263).....	4-9
4.7	User Rooms.....	4-9

TABLE OF CONTENTS (Continued)

<u>Sec/Par</u>	<u>Title</u>	<u>Page</u>
4.7.1	User Room Support Provisions	4-12
4.7.1.1	Lighting	4-12
4.7.1.2	Fire Suppression.....	4-12
4.7.1.3	Environmental Control	4-12
4.7.1.4	Electrical Power Distribution.....	4-12
4.7.1.5	Grounding	4-12
4.7.1.6	OIS.....	4-12
4.7.1.7	Experiment TV Monitoring	4-12
4.7.1.8	Master Timing	4-12
4.7.2	Signal Distribution	4-13
4.7.2.1	HRDM-Delivered Experiment Data	4-13
4.7.2.2	Experiment TV and Analog Channel.....	4-16
4.7.2.3	Instrument GSE (IGSE) Lines.....	4-16
4.8	Payload Customer Management Center (CMC)	4-16
V	LABORATORIES AND SHOPS.....	5-1
5.1	General.....	5-1
5.2	Experiment Laboratories	5-1
5.2.1	General-Purpose Laboratories	5-1
5.3	Biomedical Support Areas	5-14
5.3.1	General Operations	5-14
5.3.2	Room 3211	5-14
5.3.3	Clinical Physical Examination Room	5-14
5.3.4	Special Laboratories.....	5-13
5.3.5	Baseline Data Collection Facility (BDCF).....	5-20
5.3.5.1	General Information	5-20
5.4	Material Science Laboratories.....	5-23
5.4.1	General Description.....	5-23
5.4.2	MMAL	5-23
5.4.2.1	Electrical Power Laboratory.....	5-26
5.4.2.2	Electronics Laboratories	5-28
5.4.2.3	Environmental Testing Laboratory.....	5-33
5.4.2.4	Fluid Mechanical Laboratories.....	5-34
5.4.2.5	Lubricants and Polymers Testing Laboratory	5-43
5.4.2.6	Materials Testing Laboratory	5-45
5.4.2.7	Metallurgical Laboratory	5-48
5.4.2.8	Metrology Laboratory	5-49
5.4.2.9	Metallographic Laboratory	5-52
5.4.2.10	Coatings Evaluation Laboratory.....	5-54
5.4.2.11	Liquid Oxygen Testing Laboratory.....	5-54
5.4.2.12	MMAL Installed Utilities	5-55
5.4.3	MCAL.....	5-56
5.4.3.1	MCAL Equipment.....	5-58
5.4.3.2	MCAL Utilities	5-62
5.5	Special Purpose Areas.....	5-62
5.5.1	Rooms 1255 and 1259	5-62
5.5.2	KSC Instrument Calibration Laboratory.....	5-62
5.5.3	Experiment Integration Electrical Shop.....	5-62
5.5.4	Astronaut Breathing Air System (Room 3287).....	5-62

RELEASED

K-STSM-14.1.14

TABLE OF CONTENTS (Continued)

<u>Sec/Par</u>	<u>Title</u>	<u>Page</u>
VI	STORAGE AND OTHER AREAS	6-1
6.1	General Description.....	6-1
6.2	Receiving and Inspection	6-1
6.3	Second Floor Areas.....	6-1
6.4	Third Floor Areas.....	6-1
6.5	Fourth Floor Areas	6-3
APPENDICES		
A	Glossary	A-1
B	References	B-1

RELEASED

LIST OF FIGURES

<u>Figure</u>	<u>Title</u>	<u>Page</u>
1-1	KSC/CCAS Payload Processing Facilities.....	1-2
2-1	Operations and Checkout (O&C) Building.....	2-1
2-2	KSC Industrial Area.....	2-2
2-3	O&C Building Key Plan.....	2-3
3-1	O&C Building Area Layout.....	3-2
3-2	Plan View of Low Bay Area.....	3-3
3-3	O&C Tunnel.....	3-4
3-4	Bay Area Payload Processing Activities.....	3-6
3-5	North and South Experiment Integration Stands.....	3-11
3-6	Typical Access for Pallet and Racks in the Module-with-Pallet Configuration.....	3-13
3-7	Trunnion Support for Experiment Integration.....	3-14
3-8	Receptacle Mounting Positions on Experiment Integration Stands.....	3-15
3-9	PPCU Equipment Locations.....	3-19
3-10	PPCU User Rooms Layout.....	3-20
3-11	Workstands 2 and 3, Plan View and Elevation.....	3-22
3-12	Workstands 2 and 3, Equipment Locations.....	3-23
3-13	Overhead Bridge Access Platform, Workstands 2 and 3.....	3-25
3-14	Forward End Cone/Tunnel Hatch Access Platform.....	3-26
3-15	Pallet Access Platform.....	3-27
3-16	Spacelab 2 in Workstand 3.....	3-28
3-17	CITE Stand, View from the North.....	3-31
3-18	CITE Stand, View from the South.....	3-32
3-19	Staging and Assembly Areas.....	3-36
3-20	Class-10,000 Clean Work Area.....	3-38
3-21	ESA Pallet Being Removed from the Class 10,000 Clean Work Area....	3-39
3-22	NASA Strongback Being Used to Handle a Pallet.....	3-42
3-23	Hydraulic-Powered Scissor-Lift Work Platform.....	3-43
3-24	Four-Step Access Ladder.....	3-44
3-25	Typical Access Stepladders With and Without Handrails.....	3-44
4-1	Experiment Integration Control Room 3259.....	4-2
4-2	Spacelab Experiment Integration System and Experiment Interface Block Diagram.....	4-5
4-3	Spacelab Control Room 1, Room 3247.....	4-6
4-4	CITE Control Room.....	4-7
4-5	CITE Functional Block Diagram.....	4-8

RELEASED

K-STSM-14.1.14

LIST OF FIGURES (Continued)

<u>Figure</u>	<u>Title</u>	<u>Page</u>
4-6	Engineering Support Area (ESA), Room 3237	4-10
4-7	User Rooms	4-11
4-8	Typical User Room Layout	4-11
4-9	SPCDS Overview	4-14
4-10	Payload Customer Management Center (CMC), Room 4269	4-18
5-1	Layout of Laboratories and Shops, First Floor, East O&C Building	5-2
5-2	Layout of Laboratories and Shops, First Floor, West O&C Building	5-3
5-3	Layout of Laboratories and Shops, Second Floor, East O&C Building ..	5-4
5-4	Layout of Laboratories and Shops, Second Floor, West O&C Building ..	5-5
5-5	Special Purpose Laboratory, Room 1277	5-9
5-6	1289 Complex	5-10
5-7	Large Experiment Laboratories, Rooms 1485 - 1489	5-11
5-8	Experiment Laboratories, Rooms 2245, 2249, and 2251	5-12
5-9	Location of Biomedical Support Areas, Third Floor, O&C Building	5-13
5-10	Human Life Sciences Support Areas	5-14
5-11	BDCF Layout	5-21
5-12	Room 1493, Electrical Shop	5-64
6-1	Receiving and Inspection	6-3

RELEASED

LIST OF TABLES

<u>Table</u>	<u>Title</u>	<u>Page</u>
3-1	Cleanliness Requirements.....	3-7
3-2	Bay Area Bridge Cranes	3-8
3-3	Fluids and Gases, Experiment Integration Stands	3-16
3-4	Experiment Integration Stand Servicers	3-17
3-5	Fluids and Gases, Workstands 2 and 3.....	3-29
3-6	Spacelab GSE	3-41
4-1	Control and Monitoring Area Summary.....	4-17
5-1	Experiment Laboratory Data	5-6
5-2	Examining Room Equipment.....	5-15
5-3	Stress Laboratory Equipment	5-15
5-4	Stress Laboratory Data Support Equipment	5-16
5-5	Hematology Lab Equipment.....	5-17
5-6	Biochemical Lab Equipment	5-18
5-7	Supplemental Lab Equipment.....	5-19
5-8	BDCF Data	5-21
5-9	MMAL Locations and Space, First Floor, O&C Building	5-23
5-10	MMAL Locations and Space, Second Floor, O&C Building	5-24
5-11	Electrical Power Laboratory Equipment.....	5-25
5-12	Microelectronics and Digital Electronics Area Equipment	5-27
5-13	RF-Microelectronics Laboratory Equipment	5-29
5-14	Environmental Testing Laboratory Equipment.....	5-32
5-15	Pneumatics Laboratory Equipment.....	5-33
5-16	Hydraulics Laboratory Equipment.....	5-39
5-17	Dissection Disassembly Laboratory Equipment.....	5-40
5-18	Lubricants and Polymers Testing Laboratory Equipment	5-42
5-19	Materials Testing Laboratory Equipment	5-44
5-20	Metallurgical Laboratory Equipment	5-47
5-21	Metrology Laboratory Equipment.....	5-48
5-22	Metallographic Processing and Preparation Laboratory Equipment	5-51
5-23	Coating Evaluation Laboratory Equipment	5-53
5-24	Liquid Oxygen Testing Laboratory Equipment.....	5-54
5-25	MMAL Installed Utilities	5-54
5-26	MCAL Locations and Space	5-56
5-27	MCAL Equipment.....	5-57
6-1	Storage and Other Areas.....	6-2

RELEASED

K-STSM-14.1.14

THIS PAGE INTENTIONALLY LEFT BLANK

RELEASED

ABBREVIATIONS AND ACRONYMS

The following abbreviations and acronyms are used in this handbook. A more comprehensive listing is contained in NASA Reference Publication 1059 Revised, *Space Transportation System and associated Payloads: Glossary, Acronyms, and Abbreviations*.

A	ampere
A/C	air-conditioning
ac, AC	alternating current
AFD	aft flight deck
ALT	alternate
am	amplitude modulation
AMON	ammonia
ATE	automatic test equipment
ATM	Apollo Telescope Mount Room
AUX	auxiliary
AVE	avenue
BDCF	Baseline Data Collection Facility
Bldg	building
Btu	British thermal unit
CALCM	calcium
calib	calibration
CARB	carbon dioxide
CCAS	Cape Canaveral Air Station
CCR	control center rack
CCTV	closed-circuit television
CDMS	Command and Data Management System
CDT	countdown time
CITE	cargo integration test equipment
CL	centerline, chloride
cm	centimeter
CMC	Customer Management Center
COL	column
COMM	communication
COMP, comp.	computer, compressed
COND	conditioner
CPU	central processing unit
CR	card reader, control rack
CRT	cathode ray tube
CWA	clean work area
CX	character transmit
D	dryer
D/A	digital to analog
DACH	direct access channel
dBA	decibel (s) absolute
dc	direct current
DDSS	Data Display Subsystem

RELEASED

K-STSM-14.1.14

ABBREVIATIONS AND ACRONYMS (Continued)

DE-MAO	Engineering Development Directorate's Materials Analysis Office
DEC	Digital Electronics Corporation
DECOM, DECOMM	decommutator
des	designator
DET	detector
DIST, DISTR	distributor
DMM	Digital multimeter
DN	down
DU	display unit
DVM	digital voltmeter
DX	digital transmit
E	equipment
E&O	Engineering and Operations (Building) (CCAS)
ECE	experiment checkout equipment
ECG	electrocardiogram
ECIO	experiment computer input/output
ECS	Environmental Control System
EGSE	electrical ground support equipment
ELEC	electrical
ELEV	elevator
EMPRESS	Expert Mission Planning and Replanning Scheduling System
EMS	Environmental Monitoring System
ENT	ear, nose, throat
ENVIRON	environmental
EOG	electro-oculography
EPD	emergency procedures document
EPDB	experiment power distribution box
EPDS	Experiment Payload Distribution System
EQMT	equipment
ESA	European Space Agency, Engineering Support Area
ESA 60	Explosive Safe Area 60 (CCAS)
EXP, EXPMT	experiment
fc	footcandle
FCE	flight crew equipment
FM	frequency modulation
FMDM	flexible multiplexer/demultiplexer
ft, FT	foot
g	gravity
gal	gallon
GAS	getaway special
GEN	generator
GHe	gaseous helium
GHz	gigahertz
GMT	Greenwich mean time
GN2	gaseous nitrogen
GO2	gaseous oxygen
GP	general publication

ABBREVIATIONS AND ACRONYMS (Continued)

GPC	general-purpose computer
GSE	ground support equipment
H	high
h	hour
H ₂ O	water
HB	handbook
Hct	hematocrit
HDQS	Headquarters
HEPA	high efficiency particle accumulator
Hg	mercury
Hgt	height
HIM	hardware interface module
HITS	High Rate Multiplexer Input/Output Test Station
HIU	hardware interface unit
hp	horsepower
HP	Hewlett-Packard
HPF	hazardous processing facility
HRDE	high rate data equipment
HRDM	high rate demultiplexer
HRM	high rate multiplexer
HRMTS	high rate multiplexer test station
Hz	hertz
I	instrumentation
I/F	interface
I/O	input/output
IBM	International Business Machines
IGSE	instrument ground support equipment
in	inch
INTEG	integrated
IPS	Instrument Pointing System
IRIG	Interrange Instrumentation Group
JSC	Lyndon B. Johnson Space Center
KB	keyboard
KBPS	kilobit(s) per second
kg	kilogram
kHz	kilohertz
KSC	John F. Kennedy Space Center
kVA	kilovolt ampere
kW	kilowatt
l	liter
lb	pound
LCC	Launch Control Center
lm	lumen
LOC	location
LOX	liquid oxygen
LP	line printer
LPS	Launch Processing System

K-STSM-14.1.14

ABBREVIATIONS AND ACRONYMS (Continued)

LSSF	Life Science Support Facility (CCAS)
LSSM	Launch Site Support Manager
m	meter
MAC	multi-access computer
MAG	magnetic
MAX,max	maximum
mbps	megabit(s) per second
MCAL	Microchemical Analysis Laboratory
MCDS	Multifunction CRT Display System
MCV	mean corpuscular volume
MDM	multiplexer/demultiplexer
MEM	memory
MET	mission elapsed time
mg	milligram(s)
MGSE	mechanical ground support equipment
MHz	megahertz
MI	mile(s)
MIN, min	minimum, minute
mm	millimeter
MMAL	Malfunction/Material Analysis Laboratory
MMC	Metabolic Measurement Cart
MMSE	multiuse mission support equipment
MMU	mass memory unit
MON	monitor
MSDS	Material Safety Data Sheet
MSE	mission (or mechanical) support equipment
MSS	mission specialist station
MT	magnetic tape
MTU	master timing unit
MVAK	module vertical access kit
N ₂	nitrogen
N/A	not applicable
NASA	National Aeronautics and Space Administration
NEMA	National Electrical Manufacturer's Association
NO ₂	nitrogen dioxide
No.	number
O&C	Operations and Checkout (Building)
O ₂	oxygen
Observ, obs	observation
OIS	Operational Intercommunication System
OMBUU	Orbiter Midbody Umbilical Unit
OMI	Operations and Maintenance Instruction
OOS	On-Orbit Station
OPF	Orbiter Processing Facility
OPS, ops	operations
OTV	Operational Television
P&AW	Paging and Area Warning
P/L	payload

ABBREVIATIONS AND ACRONYMS (Continued)

P/P	printer/plotter
PACAS	Personnel Access Control Accountability System
PC	personal computer
PCM	pulse code modulation
PCMMU	pulse code modulator master unit
PCU	Payload Checkout Unit
pH	measurement of acidity of alkalinity
PHSF	Payload Hazardous Servicing Facility
PI	Principal Investigator
PITS	Payload Integration Test Set
PNL	panel
POCC	Payload Operations Control Center
PPCU	Partial Payload Checkout Unit
PPF	payload processing facility
ppm	part(s) per million
pps	pulse(s) per second
PSS	Payload Specialist Station
PSSIT	pallet segment support integration trolley
PSSU	patch survey and switching unit
PSTF	Payload Spin Test Facility (CCAS)
PT	prothrombin time
PTT	partial thromboplastin time
PTVS	Payload Television Video System
PVC	polyvinyl chloride
PWR, pwr	power
RAU	remote acquisition unit
RBC	red blood cell (count)
REF, ref.	reference
Refig.	refrigerator
Req.	requirement
RF, rf	radio frequency
RFI	radio frequency interference
RH	relative humidity
RI	Rockwell International
RM	room
rms	root mean square
RR	restroom
RSS	Rotating Service Structure
RTG	radioisotope thermoelectric generator
RX	receive
s	second
SAA	satellite accumulation area
S/C, SC	spacecraft, strip chart
SAEF	Spacecraft Assembly and Encapsulation Facility
SCR	strip chart recorder
SDR	signal distribution rack
SIG	signal
SIM	simulate (tion)
SIP	standard interface panel
SL	Spacelab

K-STSM-14.1.14

ABBREVIATIONS AND ACRONYMS (Continued)

SMAB	Solid Motor Assembly Building (CCAS)
SPCDS	Spacelab Payload Command and Data System
SPORT	Smart Processing of Real-Time Telemetry
SSP	Space Shuttle Program
ST	street
STA	station
STD	standard
STSM	Space Transportation System manual
SWM	serial word monitor
SWS	serial word simulator
TAA	temporary area authorization
TAIR	test and inspection record
TCO ₂	total carbon dioxide
Temp	temperature
TLC	telecommand
TLM	telemetry
TS	test stand
TSP	twisted shielded pair
TSU	test signal switching unit
TX	transmit
TYP	typical
UHF	ultra-high frequency
V	volt
v/v	volume-to-volume methane equivalent
VAB	Vehicle Assembly Building
VAS	vertical access simulator
VFI	verification flight instrumentation
VHF	very high frequency
VIB	Vertical Integration Building (CCAS)
VIP	very important person
VPF	Vertical Processing Facility
VRSS	video routing switcher system
W	watt, wide, washer
WAD	work authorization document
WBC	white blood cell (count)
WP	work platform, word processor
WPS	word processing system
Xo	X-axis of orbiter
a	alpha
degrees C	degree Centigrade
degrees F	degree Fahrenheit
γ	gamma
μ	micron(s)
%	percent
+/-	plus or minus
∅	phase

FOREWORD

Launch site payload processing facilities are described in three levels of documentation. These levels and their purposes are:

- a. K-STSM-14.1, *Launch Site Accommodations Handbook for Payloads* - This document provides a brief summary of each facility and a general description of John F. Kennedy Space Center (KSC) launch and landing site operations.
- b. Facility Handbooks - Each handbook provides a narrative description of the facility and its systems. Also, general operating rules, regulations, and safety systems are discussed in these handbooks. Handbooks available are:

K-STSM-14.1.1	<i>Facilities Handbook for Building AE</i>
K-STSM-14.1.2	<i>Facilities Handbook for Building AO</i>
K-STSM-14.1.3	<i>Facilities Handbook for Building AM</i>
K-STSM-14.1.4	<i>Facilities Handbook for Hangar S</i>
K-STSM-14.1.6	<i>Facilities Handbook for Explosive Safe Area 60A</i>
K-STSM-14.1.7	<i>Facilities Handbook for Spacecraft Assembly and Encapsulation Facility Number 2</i>
K-STSM-14.1.8	<i>Facilities Handbook for Radioisotope Thermoelectric Generator Storage Building</i>
K-STSM-14.1.9	<i>Facilities Handbook for Life Sciences Support Facility Hangar L</i>
K-STSM-14.1.10	* <i>Payload Accommodations at the Rotating Service Structure</i>
K-STSM-14.1.12	<i>Facilities Handbook for Vertical Processing Facility</i>
K-STSM-14.1.13	* <i>Orbiter Processing Facility Payload Processing and Support Capabilities</i>
K-STSM-14.1.14	* <i>O&C Building Payload Processing and Support Capabilities</i>
K-STSM-14.1.15	<i>Facilities Handbook for Payload Hazardous Servicing Facility</i>

These facility handbooks are not under configuration control; however, they will be reissued as necessary in order to maintain usefulness to customers in their planning for launch site processing of their payloads.

* These handbooks are titled differently because the facilities also serve functions other than payload support. Only the payload accommodations are described in these documents.

RELEASED

K-STSM-14.1.14

- c. Standard Interface Documents (SID's) - These reference documents are intended to provide the payload-to-facility interface design details for these launch site payload processing facilities:

SID 79K12170	<i>Payload Ground Transportation Canister</i>
SID 79K16210	<i>Vertical Processing Facility</i>
SID 79K16211	<i>Horizontal Processing Facility (O&C Building)</i>
SID 79K17644	<i>Payload Strongback</i>
SID 79K18218	<i>Launch Pad 39A</i>
SID 79K28802	<i>Launch Pad 39B</i>
SID 79K18745	<i>Orbiter Processing Facility (OPF)</i>
SID 79K24867	<i>Hangar L - Life Sciences Support Facility</i>
SID 82K00463	<i>Payload Environmental Transportation System (PETS) Multiuse Container</i>

SID's are not available for all launch site payload processing facilities. In these cases, the facility handbooks must be used for design interface information and customers should ask for verification of any areas of concern. When SID's are available, they should be used as the official definition of the facility interfaces. There are some SID's for which there are no handbooks; e.g., the payload strongback and the Payload Environmental Transportation System (PETS) multiuse container. In these cases, the SID's must be used.

Customers may obtain copies of any of these documents through the assigned Launch Site Support Manager (LSSM).

RELEASED

K-STSM-14.1.14

SECTION I

INTRODUCTION

1.1 PURPOSE

The purpose of this handbook is to provide basic information concerning the horizontal payload processing in the Operations and Checkout (O&C) Building. This book contains facility and equipment descriptions, monitoring and control capabilities, and laboratory and shop availability. The building and location are shown in figure 1-1.

1.2 SCOPE

This handbook is intended to be used by the payload organizations as a guide for planning of payload activities in the O&C Building and describes this building's capabilities and standardized interfaces.

1.3 CUSTOMER CHARGE

The use of the O&C for payload integration is generally considered a standard service for National Aeronautics and Space Administration (NASA) payloads. Support or payload stand-alone testing, unique services, laboratory services, or use of user rooms could result in optional charges.

1.4 FACILITY ACCOMMODATIONS

The facility accommodations available to the customer as identified herein provide support to a variety of NASA and NASA customer payloads, and may accommodate payload elements being processed simultaneously. The John F. Kennedy Space Center (KSC) Launch Site Support Manager (LSSM) will determine launch site facility utilization assignments based on the Space Shuttle customer requirements and overall Space Shuttle schedules. The customer must remain cognizant during design development of the necessity to share these facilities with other payload elements. Individual payload customer requirements should be coordinated closely with the KSC LSSM to assure that support is available when needed.

Customers should be familiar with the *Operations and Checkout Building M7-355, Emergency Procedures Document (EPD)*, OMI No. S9910.

1.5 HAZARDOUS AND CONTROLLED WASTE

In advance of their arrival, customers will fill out KSC Form 26-551, "Process Waste Questionnaire," for any hazardous and controlled waste they expect to generate at KSC during processing. All waste generated at KSC will be managed in accordance with the requirements of KHB 8800.7, *Hazardous Waste Management*.

Once a customer has identified launch site waste generations, a satellite accumulation area (SAA) will be set up in facilities denoted as points of generation of these wastes.

These SAA's will be established in order to comply with the intent of the Resource and Recovery Act of 1976, which was established to institute a national program to control

K-STSM-14.1.14

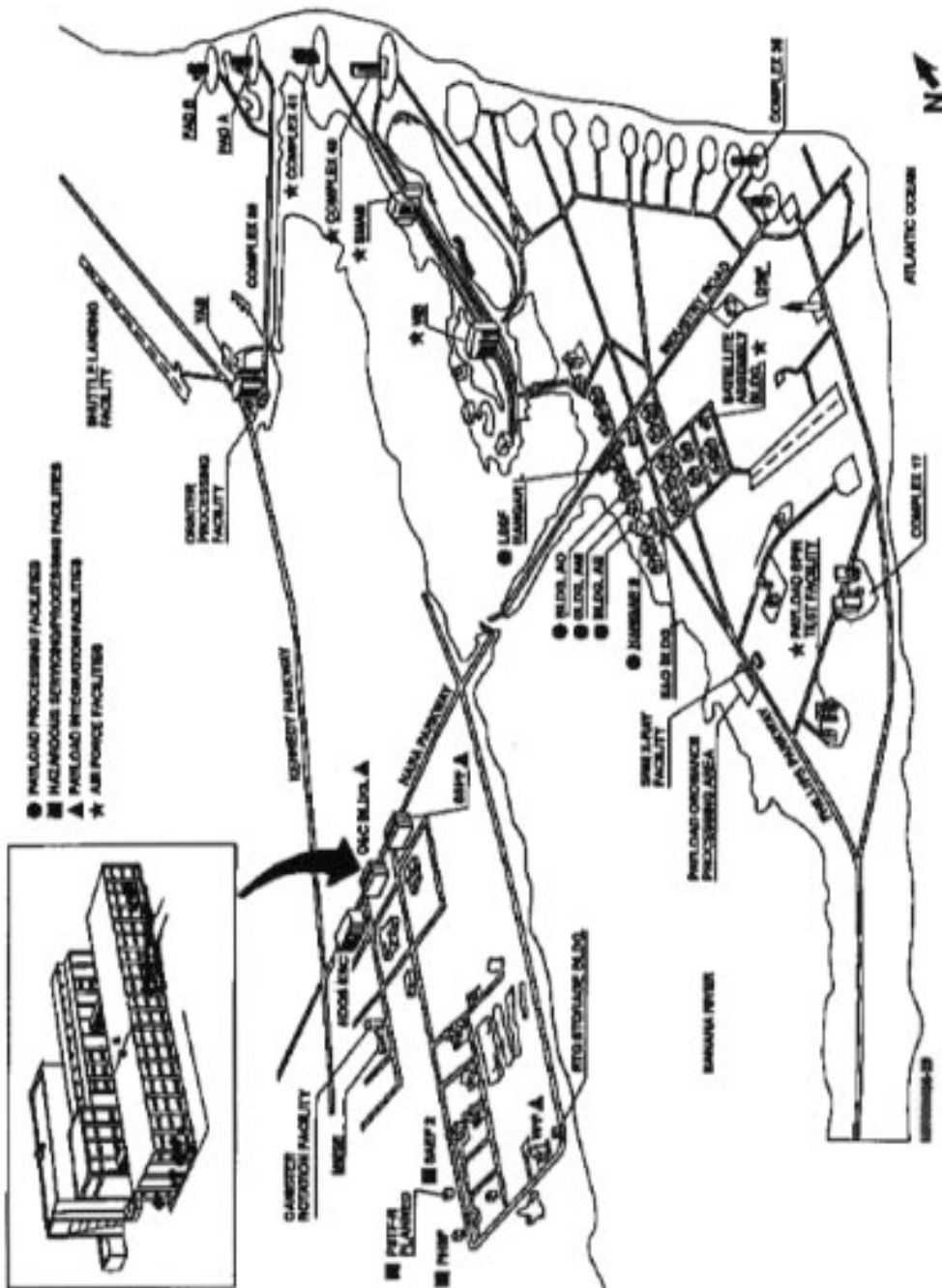

Figure 1-1. KSC/CCAS Payload Processing Facilities

RELEASED

K-STSM-14.1.14

the generation, storage, transportation, treatment, and disposal of hazardous and controlled waste.

Customers should coordinate any waste operations or problems with their assigned LSSM. Regulations for the use of, control of, and disposal of waste at the launch site are strictly enforced

1.6 HAZARDOUS SUBSTANCE INVENTORY

A Material Safety Data Sheet (MSDS) is required for each hazardous substance brought to KSC for payload processing. The MSDS is submitted to CG-LSO-2 who forwards a copy to each of the organizations listed below.

- CG-LSO-2/Payload LSSM
- MD-MED/M. Cardinale
- RT-SOE-3/(Safety Specialist for payload)
- BIO-1/G. Camomilli (Hangar L processed payloads only)
- MDS&DS-F676/J. Scarpino (for all payload processing facilities except Hangar L)

Inventory and accountability of all hazardous substances will be managed in accordance with the requirements of KHB 8800.6, *KSC Environmental Control Handbook*.

Additionally, the customer must submit specific information for each substance brought on-site to the LSSM. This data will be used to comply with the Superfund Amendments and Reauthorization Act, 1986 (SARA Title III).

RELEASED

K-STSM-14.1.14

THIS PAGE INTENTIONALLY LEFT BLANK

RELEASED

SECTION II

FACILITY DESCRIPTION

2.1 GENERAL

The O&C Building is a five-story structure containing 55,926 m² (602,000 ft²) of offices, laboratories, astronaut quarters, and payload bay areas. It is in the KSC Industrial Area immediately east of the KSC Headquarters Building. The O&C Building bay area was used for assembly and test of the Apollo spacecraft during the Apollo Program and has been modified for the Space Shuttle era. An exterior view of the O&C Building from the northeast is shown in figure 2-1. Figure 2-2 shows the Industrial Area location.



Figure 2-1. Operations and Checkout (O&C) Building

RELEASED

K-STSM-14.1.14

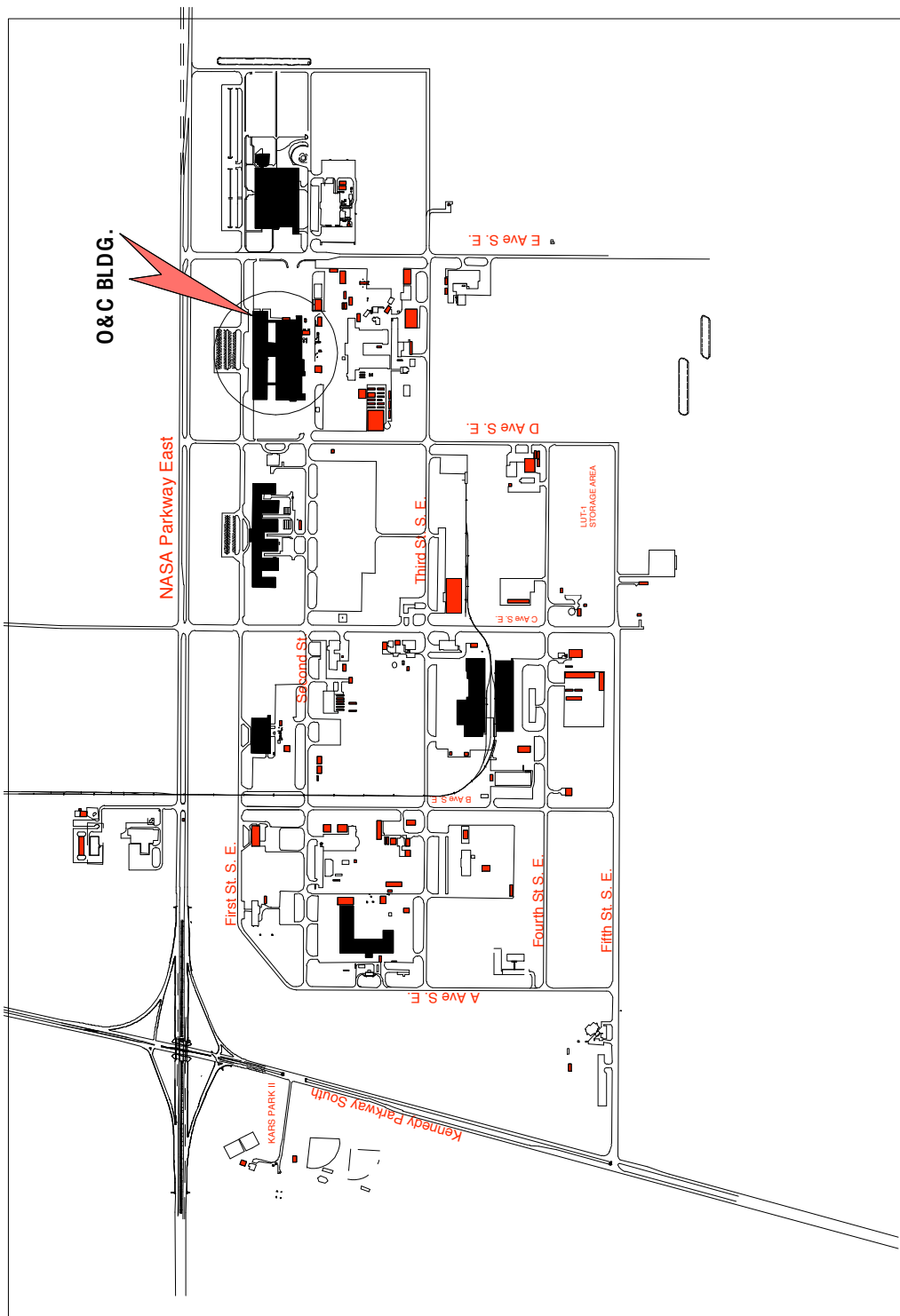

Figure 2-2. KSC Industrial Area

RELEASED

2.2 FUNCTIONS

Payloads that are integrated and processed horizontally are received, assembled, and checked out in the O&C Building. They are then transported either to the Orbiter Processing Facility (OPF) for mating with the orbiter or to the Vertical Processing Facility (VPF) to be combined with vertically processed payloads. The O&C Building has been modified to accommodate pallet-type payloads including special structures, Spacelab configurations, and certain other Space Shuttle payloads. These payloads are generally processed through experiment-to-pallet, pallet-to-total payload, and payload-to-simulated orbiter integration and postlanding deintegration.

The O&C Building is divided into four basic areas (figure 2-3):

- a. Administration
- b. Laboratory, control, and monitor
- c. Bay area
- d. Service and support

All areas except administration will be presented in this handbook.



Figure 2-3. O&C Building Key Plan

Actual hands-on mechanical and electrical experiment and payload integration are performed primarily in the bay area. Laboratories and shops provide the off-line payload support to the integration conducted in the bay area. Control and monitor functions are provided in support of the bay integration. The service area contains support systems for the bay area such as shipping and receiving. Bonded storage areas are included in the shaded portions of figure 2-3. These permanently set-aside storage areas, not mission specific, will be addressed in section VI.

RELEASED

K-STSM-14.1.14

2.3 ACCESS

2.3.1 PERSONNEL ACCESS. Access to the payload processing and support areas of the O&C Building is controlled, either monitored by access control monitors or by electronic devices. A KSC badge and area permit with numbers 40 and 73 are required for access. A magnetic Personnel Access Control Accountability System (PACAS) card is required, in addition to the KSC badge and area permit, to gain access on all shifts.

All personnel must check in with the O&C Highbay Operations Desk upon entering the highbay. Personnel with a "To Be Escorted" temporary area authorization (TAA) must be escorted by a properly badged person at all times while in the O&C highbay. The maximum number of persons that may be escorted by one person is three. The CITE CCMS Set required area #40 for access. The CITE CCMS is located in rooms 3227, 3233, 3237, and 3245.

Laboratories, shops, experiment support areas, and control and monitoring rooms are along an east-west corridor the length of the building on floors 1, 2, 3, and 4. Access to these areas and rooms is from the corridor. Third floor access is limited because the astronaut quarters are near the west end of the building. However, lab and control rooms are accessible from the middle and east end of the third floor corridor. Several stairwells connect these areas and the other floors.

Personnel access to the bay area is obtained on the north side from the first floor corridor (monitor posts A1 and C7), and from the south side at monitor post D14. The PACAS is activated and monitored at all times for access control at the A-1 entrance. Access to C-7 and D-14 is during operational hours only.

2.3.2 EQUIPMENT ACCESS. Large items of ground support equipment (GSE) and flight equipment enter the O&C Building through the east vertical lift door of the bay area or the shipping and receiving area (room 1469). The east bay area door can be opened for clear access 24.4 m (80 ft) high and 12.2 m (40 ft) wide. The door from room 1469 is 4.6 m (15 ft) high and 6.1 m (20 ft) wide. Small equipment items can be brought in through the personnel access doors (A-1, C-7, and D-14).

2.3.3 WHEEL LOADING PROFILE. Trucks and heavy equipment entering the O&C high bay through the east vertical door must not exceed stated wheel load markings painted on the floor. The maximum uniform, wheel, and concentrated loads, as well as formulas for determining wheel loads, are provided in the following subparagraphs.

2.3.3.1 Uniformly Distributed Loads. The maximum uniformly distributed load, on the assembly and test floor, should not exceed 250 pounds per square foot.

2.3.3.2 Wheel Loads. The wheel loads, on the assembly and test area floors, should be limited to the maximum indicated as follows:

- a. Floor slab between columns 1 and 7 - 15,000 pounds
- b. Floor and tunnel slab between columns 7 and 8 - 6,500 pounds
- c. Floor and tunnel slab between columns 9 and 11 - 9,600 pounds
- d. Floor and tunnel slab between columns 11 and 35 - 15,000 pounds

RELEASED

The formulas for determining wheel loads are as follows:

(NOTE: Situations that do not meet any of the following formula criteria must have a design study, to verify safe wheel loading limits.)

- a. Two axle truck -
 - P = rear dual wheel load = $(0.80 \times w) 0.50$
 - W = total weight of truck and load in pounds
- b. Three axle truck -
 - P = rear dual wheel load = $(0.80 \times w) 0.50$
 - P = rear wheel load, tandem axle = $(0.80 \times w) 0.50 \times 0.50$
 - W = total weight of truck and load in pounds
- c. Payload transporter -
 - P = wheel load = W/N
 - W = total weight of transporter and load in pounds
 - N = transporter number of wheels
- d. Forklift -
 - P = front wheel load = $(0.80 \times w) 0.50$
 - W = total weight of forklift and load in pounds

2.3.3.3 Concentrated Loads. Before any concentrated load is applied to the floor of the assembly and test areas, a timber or steel mat shall be placed under the load to distribute the weight. The size of the mat shall be such as to limit the uniformly distributed load to the maximum of 250 pounds per square foot.

2.3.4 EMERGENCY EGRESS. On the south side, first floor, there are seven emergency egress routes to the outside of the building:

- a. Between processing rooms A and B (east end - Door D-10)
- b. Between processing rooms B and C (middle - Door D-14)
- c. Processing room C (middle - Door D-15)
- d. Room 1485 (middle - Door D-17)
- e. Room 1489 (middle - Door D-18)
- f. Room 1493 (west End - Door D-19)
- g. Between rooms 1493 and 1497 (west end - Door D-20).

On the east end through Door D-2, located in the east high bay vertical-lift door.

On the west end through Door D-23 in the northwest corner of the bay area.

On the north side, first floor through Door A-1 on the east end and Door C-7 on the west end.

RELEASED

K-STSM-14.1.14

In the Altitude Chambers at the north side on the second level.

All emergency egress exits are marked by lighted exit signs.

2.4 RESTRICTIONS

The O&C Building bay, laboratory, and control areas have controlled environments, and no manufacturing operations are permitted in these areas. Simple manufacturing tasks can be performed in the shops and service and support areas. Hazardous operations are kept to a minimum.

2.5 OPERATING REGULATIONS

Access to the stands and controlled areas in the flight hardware processing areas is controlled. General work area rules for personnel working on the stands that contain flight hardware are:

- a. Entrance areas are provided with tacky mats and must be used prior to ingress.
- b. Smock exchange station is located at the highbay east end instrumentation library.
- c. Tobacco products, food, beverages, chewing gum, and flame-producing devices are prohibited.
- d. All personnel working in the controlled area are required to log in with the access monitor. Completion of the sign in/sign out log listing the particular work authorization document (WAD), tools, equipment, solvents, and chemicals to be utilized is also required.
- e. All tools must be tethered when working over flight hardware. Badges must be placed on the badge board in the proper slot indicating where personnel will be working (ie., workstand, pallet, module, upper level or ground level).
- f. Do not take items containing mercury or glass near flight hardware.
- g. Ten people are the maximum allowed in the Spacelab module at one time. Pallet loading shall be six persons maximum with all panels installed, three persons maximum with any two adjacent panels removed, and one person maximum with three or more panels removed.
- h. Three persons or 226.8 kg (500 lb) maximum are allowed on each double access platform (portable access platform).
- i. Use of flammable liquids and hazardous substances requires coordination with operations.

RELEASED

- j. Approved safety harnesses and lanyards shall be worn whenever personnel are required to work close to an unprotected edge of an elevated platform, stand, or other structure where there is a danger of falling.
- k. Personnel shall don clean room garments, coveralls or smock, cap, foot coverings, and gloves, tether "eyeglasses" and remove or tape rings and watches. All protective clothing should be removed before leaving the controlled area.
- l. All work using non-flame producing heating devices, i.e., soldering gun, heat gun, heat lamp, will require a welding and burning permit, KSC Form 2-13 if:
 - 1) Work will be performed within 10 feet of flight hardware,
 - 2) Work will be performed within 10 feet of hazardous areas (explosives or flammable vapors present),
 - 3) Work is performed in areas protected by a Halon extinguisher system or water deluge system,
 - 4) Work is performed in a controlled area.

Obtain the welding and burning permit from the facility Manager, per SP 8.056, prior to starting work.

Specific instructions are posted for each stand area.

2.6 ELECTRONIC SECURITY SYSTEM

The O&C high and low bay clean room areas are secured at all times by means of the PACAS, described in paragraph 2.3.1.

2.7 PAGING AND AREA WARNING (P&AW)

All areas of the O&C Building are part of the KSC administrative Paging and Area Warning (P&AW) System. Speakers are located throughout the building--in the office or administrative area; the laboratory, control, and monitor area; the bay area; and the service and support area. The P&AW System is used to inform personnel of emergency conditions such as adverse weather and fire alarms, as well as for public announcements. The bay area has an additional paging feature described in subsection 3.1.13.4.

RELEASED

K-STSM-14.1.14

THIS PAGE INTENTIONALLY LEFT BLANK

RELEASED

SECTION III

BAY AREA

3.1 GENERAL

The bay area in the O&C Building (figure 3-1) is 198.1 m (650 ft) long and a uniform 25.9 m (85 ft) wide, except in the high bay at the east end where it is 11.7 m (38 ft 5 in) wide. It is divided into a high bay area 53.3 m (175 ft) long and 31.7 m (104 ft) high, and a low bay 144.8 m (475 ft) long and 21.3 m (70 ft) high.

3.1.1 HIGH BAY. The high bay on the east end contains the storage and refurbishment area at the 7.9 m (26 ft) level for the horizontal sling kit and for the multiuse mission support equipment (MMSE) strongback, which is used for handling the horizontally integrated payload elements in the O&C Building and in the OPF. The high bay also serves as the parking area for the MMSE payload canister and transporter during payload preparation and canister loading for transport. The high bay door on the east end is a six-leaved vertical-lift metal door 24.4 m (80 ft) high and 12.2 m (40 ft) wide with pneumatically operated door seals. The module vertical access simulator is also located in the high bay.

3.1.2 LOW BAY. The low bay is the main area for horizontally processed payloads. The major facility elements in the low bay are:

- a. Two integrated assembly and checkout workstands
- b. Two experiment integration workstands
- c. Cargo integration test equipment (CITE) stand
- d. Rack, floor, and pallet stand (Mideast stand)
- e. End cone stand area
- f. Tunnel maintenance area
- g. Staging and assembly areas
- h. Class 100,000 clean work area

Figure 3-2 is a plan view of these low bay payload facilities. Figure 3-3 is a view of the O&C tunnel. These facilities will be discussed in detail in this section.

RELEASED

K-STSM-14.1.14

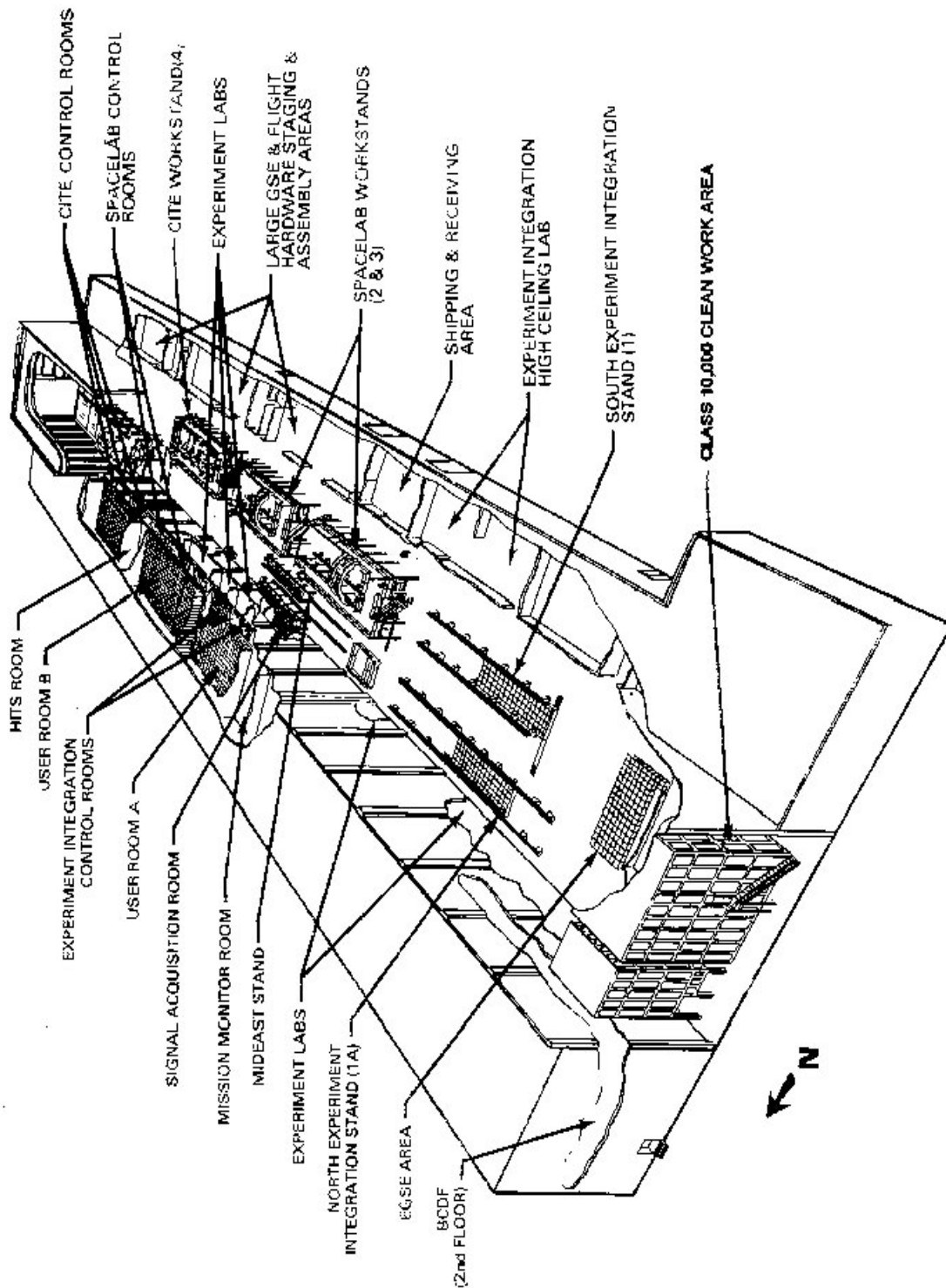
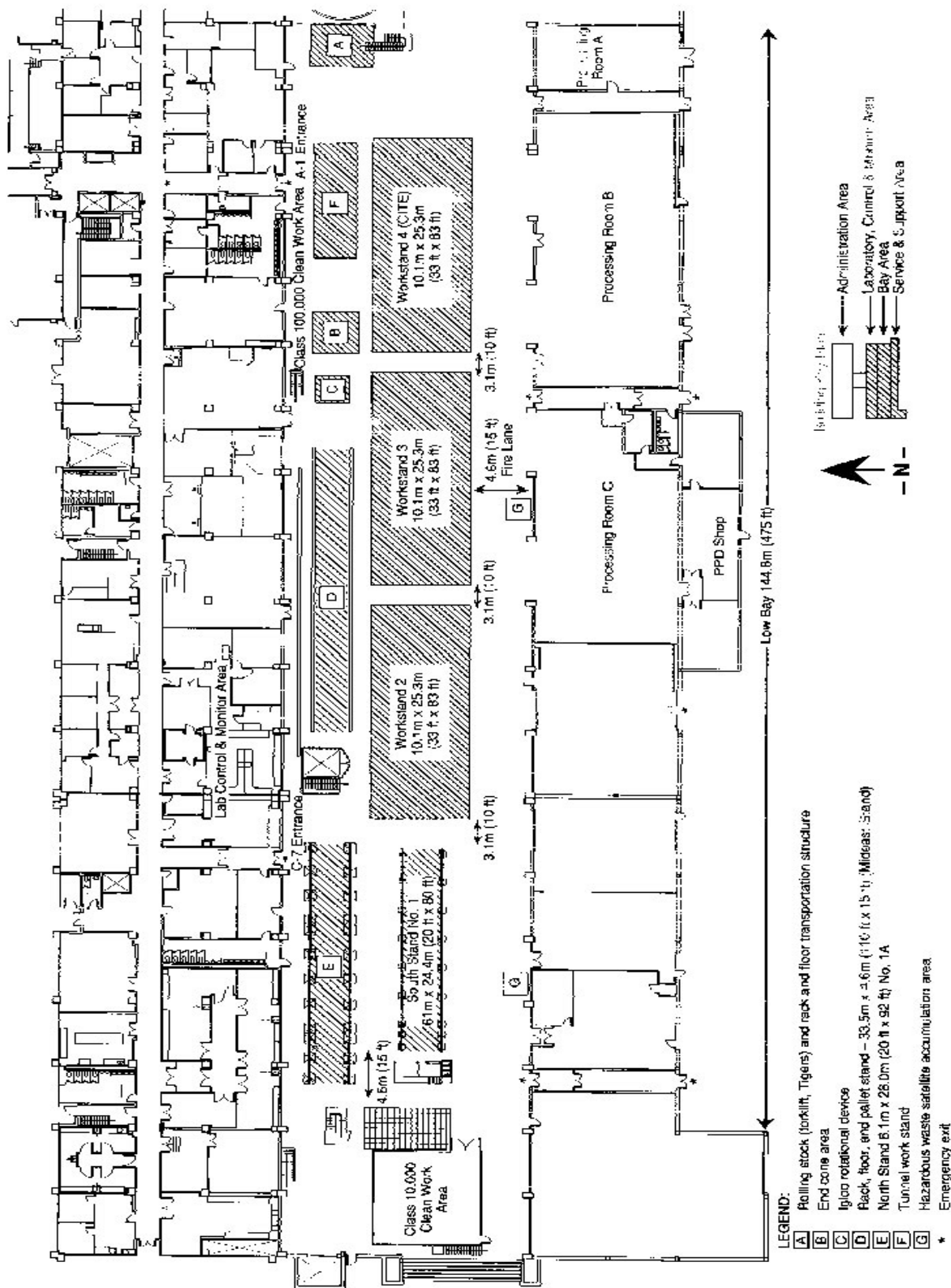

Figure 3-1. O&C Building Area Layout

RELEASED



RELEASED

Figure 3-2. Plan View of Low Bay Area

K-STSM-14.1.14

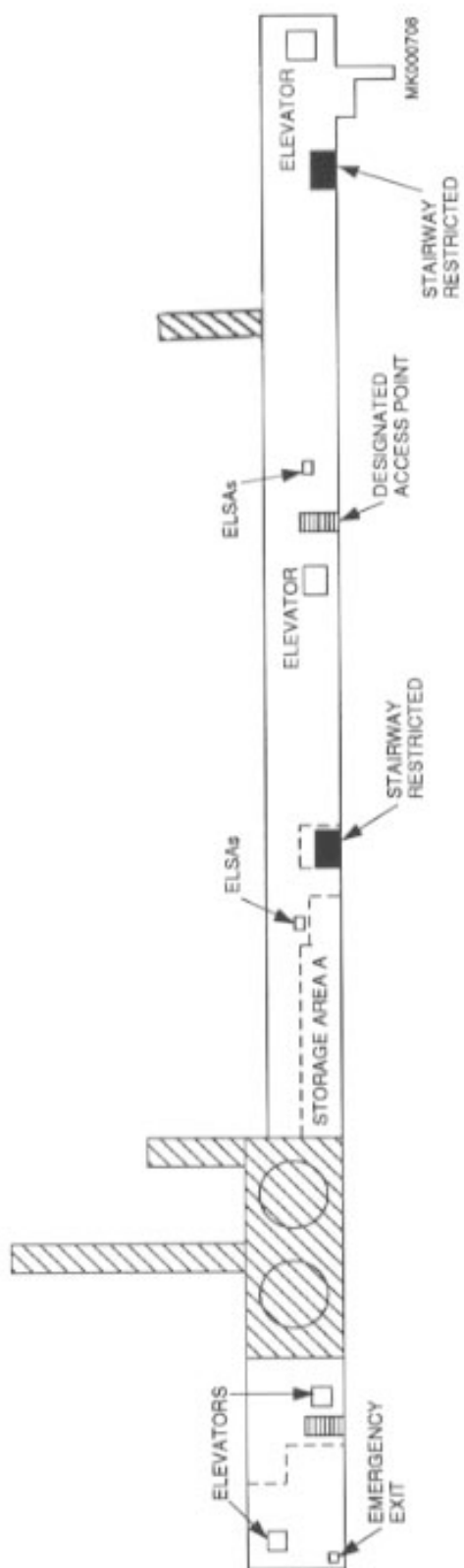

- 1) Access to shaded areas requires the buddy system and a portable oxygen monitor.
- 2) Enter tunnel at designated access points.
- 3) Evacuate immediately through nearest stairwell if alarms occur.

Figure 3-3. O&C Tunnel

RELEASED

3.1.3 PAYLOAD PROCESSING ACTIVITIES. The area processing activities include staging, experiment integration, payload integration and verification, and postlanding deintegration for horizontally processed payloads. The bay area is capable of supporting several payloads at the same time in different stages of integration and deintegration. Figure 3-4 depicts the processing flow and defines the integration levels of the area.

3.1.4 ENVIRONMENTAL CONTROL. The high and low bay area provides a visually-clean working area (CWA). Air quality is rated class 100,000 clean. The Apollo Telexcope Mount Room (ATM) is rated as a level 3 CWA although it can be maintained as a level 2 CWA if stringent controls are adhered to. The test stands and specific work areas are level 4 CWA's. Both the assembly and test area and off-line labs are level 4/5 CWA's. Table 3-1 presents more detailed environmental control data.

3.1.5 ILLUMINATION. The high and low bays are lighted by ceiling-mounted fixtures. Each fixture has a 1000-W incandescent lamp and a 1000-W metal halide lamp with an integral constant wattage mercury-vapor transformer. The metal halide and incandescent lamps are independently controlled. The metal halide lamps provide approximately 753.5 lm/m^2 (70 fc); a total of 1076.4 lm/m^2 (100 fc) is provided when both incandescent and metal halide lamps are lighted. In case of normal power and lighting failure, emergency incandescent fixtures are strategically located throughout the area. Lighting fixtures installed in and around the workstands will be discussed under the subsection for each stand.

3.1.6 GSE AND SERVICES. Mechanical and electrical GSE and services required to support the payload assembly and testing are located in and around the workstands. The GSE and services available include alternating current (ac) and direct current (dc) power, compressed air, fluids, a gas vent system, central vacuum cleaning, and handling and access equipment.

Electrical services on the north wall of the bay area are 60-Hz ac power of 120/208-V, 1- and 3- \emptyset , 30-, 60- and 100-A; and 480-V, 1- and 3- \emptyset , 30-, 60-, 100- and 200-A. The south wall contains 60-Hz ac power of 120/208-V, 3- \emptyset , 60- and 100-A and 480-V, 3- \emptyset , 60-A. The exterior east wall contains 60-Hz ac power of 120/208-V, 3- \emptyset , 100-A; and 480-V, 3- \emptyset , 100- and 200-A.

The equipment and services specific to each stand will be detailed in the subsection for each stand. Interface details are provided in 79K16211.

3.1.7 GROUNDING. All structures, equipment, and instrumentation in the area are grounded. Copper ground plates 1.3 cm (0.5 in) thick and 20.3 cm (8 in) square are at various points in the processing rooms and on or near the workstands. Each plate has four connector lugs. The equipment ground plates are mounted to structures in the area. The instrumentation ground plates are insulated from the building steel by insulating bushings or washers. Payload-unique GSE and instrumentation must be grounded when used in the area.

3.1.8 FIRE PROTECTION AND SAFETY. Manual pull stations are located at all marked exits. The area is equipped with photoelectric (smoke) detectors in the supply and air ducts. When activated, these detectors shutdown the air handling units and send a silent alarm to KSC's central monitoring station for a fire department response.

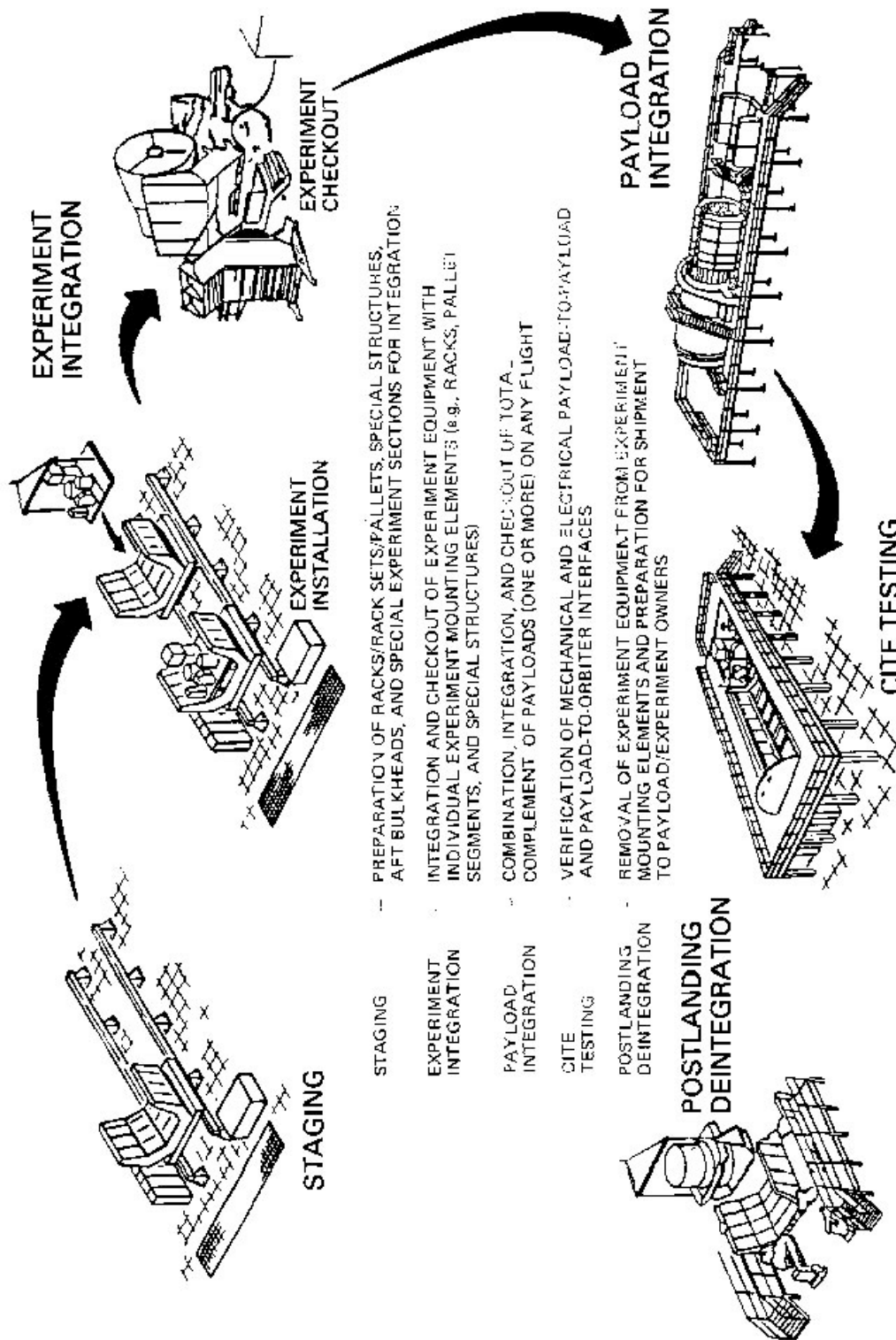

Figure 3-4. Bay Area Payload Processing Activities

RELEASED

Table 3-1. Cleanliness Requirements*

Clean Work Area Levels		Level #2	Level #3	Level #4	Level #5
Parameter	Airflow Type	Laminar	Non-Laminar	Non-Laminar	Non-Laminar
Maximum Airborne Particulate Counts Per m ³ (Per ft ³)	Req. 0.5 ≥ 0.5 μm	10,000	1415.9 [50,000]	2831.7 [100,000]	8495.1 [300,000]
	Req. 5.0 ≥ 5.0 μm	65	8.5 [300]	19.8 [700]	28.3 [1,000]
	Monitoring	Continuous	Continuous	Continuous	Monthly
Temperature (degrees C) [degrees F]	Requirement	21.7 ± 3.3 71 ± 6	21.7 ± 3.3 71 ± 6	21.7 ± 3.3 71 ± 6	21.7 ± 3.3 71 ± 6
	Monitoring	Continuous	Continuous	Continuous	Monthly
Relative Humidity (RH) (%)	Requirement	50 Max	50 Max	50 Max	50 Max
	Monitoring	Continuous	Continuous	Continuous	Monthly
Maximum Particle Fallout	Goal **	Level 200	Level 500	Level 750	Level 1000
	Monitoring	Continuous	Continuous	Continuous	Every 6 Mo.
Maximum NVR 0.1m ² /mg month	Requirement	1.0	1.0	1.0	2.0
	Monitoring	Continuous	Continuous	Continuous	Annually
Maximum Volatile Hydrocarbons (ppm) (v/v)	Requirement	15	15	15	N/A
	Monitoring	Every 2 weeks	Every 2 weeks	Every 2 weeks	N/A
Minimum Positive Pressure	Requirement	0.05 in H ₂ O	0.05 in H ₂ O	0.02 in H ₂ O	N/A
	Monitoring	Daily	Daily	Daily	N/A
Minimum Air Changes	Requirement	20/Hour	6/Hour	4/Hour	2/Hour

* During periods of operation

** Levels per KCI-HB-5340.1 continuous monitoring

NOTE: Environmental Monitoring System (EMS) continuous monitor sensors are located on each test stand at the work level. The sensors measure humidity, temperature, and airborne particles. The EMS is described in McDonnell Douglas document MDC Y0303, published January 1986.

Fire extinguishers are mounted approximately 0.6 m (2 ft.) above the floor on the north and south area walls. Extinguishers are available for wood, paper, flammable liquids, and electrical fires.

There are four eyewash and drench hose stations in the bay area. Normally they are located on the south wall at processing rooms A, B, C, and on the north wall at column 20 in the area of test stand 3. They are portable and may be moved as required to support a hazardous job in another area.

RELEASED

K-STSM-14.1.14

3.1.9 CRANE AND HOIST SYSTEM. Three overhead electrical bridge cranes service the bay area. The limit points of the crane hooks are 3.6m (12 ft) from the east and west walls and 2.1 m (6 ft 9 in) from the north and south walls. One crane services only the high bay area while the other two cranes service both the high and the low bays. Table 3-2 provides further details about these cranes. Detailed hook dimensions are shown in 79K16211.

Table 3-2. Bay Area Bridge Cranes

Crane Coverage (Number)	Capacity m ton (ton)	Hook Hgt m (ft-in)	Trolley Travel m (ft)	Bridge Travel m (ft)	Hook Speed Full Load m/min (ft/min)
High Bay (1)	24.9 (27.5)	24.1 (82-3.5)	19.5 (64)	45.1 (148)	0.6 (0 to 2)
Low Bay* (2)	24.9 (27.5)	14.6 (47-9.5)	19.5 (64)	190.5 (625)	0.6 (0 to 2)
JIB Crane	0.9 (1.0)	6.7 (22)	N/A	N/A	N/A

*Also serves high bay

The minimum distance between east and west low bay hooks is 6.7 m (22 ft). The minimum distance between low bay hooks and the high bay hook varies from 3.9 m (12 ft 9 in) to 4.2 m (13 ft 10-1/2 in).

3.1.10 AIR-BEARING PALLET SYSTEM. An air-bearing pallet system is available for internal transport within the bay area. The system consists of a cart that can be connected to facility air and 16 small pallets, each of which can support 1814.4 kg (4000 lb). The system can move the pallet segment support integration trolley (PSSIT), long and short rack and floor trolley, and the pallet transport cage with dedicated flight hardware on board into and out of the service or processing areas on the south side of the high and low bays, where ceiling heights are too low for use of the bridge crane for hoisting. One set is currently operational. In addition there are 4 large pallets, each can support 4536 kg (10,000 lb).

3.1.11 VENT SYSTEMS.

3.1.11.1 Experiment Vent System. A "clean" vent system for experiments is in place at each workstand (1, 1A, 2, 3, and CITE stands) in the bay area. There are two ports of 2 in (5.08 cm) PVC at each stand.

3.1.11.2 Vacuum Vent System. The vacuum vent system provides vacuum venting of vacuum pump exhausts, deservicing of Freon 114 cooling systems, and other GSE. There are two 5.08-cm (2-in) galvanized ports at each of the workstands 1, 1A, 2, 3, and CITE.

RELEASED

3.1.12 VACUUM CLEANING. Vacuum cleaning equipment consists of a 25-hp vacuum. Outlets are located at each workstand in the bay area (workstands 1S, 1N, 2, 3, and CITE), the class 10,000 clean work area, the north wall, and for shops and processing rooms (A, B, & C).

3.1.13 COMMUNICATIONS AND DATA HANDLING.

3.1.13.1 Operational Intercommunication System (OIS). The OIS is a multi-channel voice communication network that interconnects operational areas required for payload processing at KSC and the Cape Canaveral Air Station (CCAS). The digital OIS in the O&C Building ties the Area, the High Rate Multiplexer (HRM) Test Station and Closed-Circuit Television (CCTV) Room (1263), the Payload Checkout Unit (PCU) control rooms, the Spacelab and CITE control rooms, the Customer Management Center (CMC) (room 4269), and the user rooms. Each OIS unit can access two selectable channels. If the OIS is in the active-monitor mode, all four headsets can talk and listen on one channel while simultaneously monitoring a second channel. In the dual mode, two headsets can talk and listen on the same or a different selected channel with no monitor capability for either pair of headsets. The OIS units are mounted on the railings, pedestals, and columns of the stands in the area, as well as on the north and south area walls near work areas. The OIS also has the capability to link to LC 39 areas.

3.1.13.2 Operational Television (OTV). OTV can provide video surveillance and recording of payload processing in all operational areas (SAEF 2, PHSF, etc.) to the O&C Building. Although the camera mounts and cable are installed in the bay area, OTV is not available as a standard service. OTV must be requested by the Shuttle customer. Payload processing in the OPF, the Rotating Service Structure (RSS), and at the launch pad can be observed through the OTV system. OTV distributors in these areas route the video by way of the payload television video system (PTVS) video routing switcher system (VRSS) to monitors in the O&C Building control and monitor rooms.

3.1.13.3 Telephones. The bay area contains commercial telephones in several places available from floor level: at the three access control monitors' desks, at the control desk for each stand, and on the west side under each stand.

3.1.13.4 Paging and Area Warning System. The high and low bays are part of the KSC P&AW System. Speakers are mounted on the walls to inform personnel in the bay area. In addition, each workstand and operations desk has its own paging system for use during specific work in the stand. There are two portable speakers available on each of the experiment integration workstands. Workstands 2, 3, and 4 have eight speakers each. They are mounted on each stand's second level as well as below the second level for personnel on the floor. These speakers are mounted on the corners of each stand. All four workstands can be switched manually to allow one stand's system to page all stands.

3.1.13.5 Timing. Timing in Interrange Instrumentation Group (IRIG) A, B, and H formats for Greenwich mean time (GMT) and mission elapsed time (MET) is provided in the bay area. Countdown clock displays are located on or near each workstand.

3.1.13.6 Workstand Bulkhead Interface Assembly. Each workstand has provisions for interface with the wideband transmission lines for experiment checkout equipment (ECE) command and data transmission between user room ECE and workstand ECE or experiment and ECE lines. There are 52 lines available at the experiment integration

K-STSM-14.1.14

stands, 38 lines at each of stands 2 and 3 (Spacelab stands), and 38 lines at workstand 4 (CITE stand). The bulkheads are overhead of the ground level (under the access walkways) on workstands 2, 3, and 4. On the experiment integration stands, the bulkheads are mounted beneath the rails.

Specific data communications and data handling information are presented with each area. Because these systems are quite extensive and complex, only an overview of equipment and capabilities is covered. Appropriate customer manuals and texts are referenced for more detailed information.

3.2 WORKSTANDS

The major workstands 2, 3, and 4 (CITE), shown previously in figure 3-2, provide movable left- and right-hand longeron fittings and load monitoring capability, and they can accommodate the European Space Agency (ESA)-provided GSE. The stands serve as the primary structural interface between the trunnions and the simulated bridge rail. Workstands 1 north and 1 south, the experiment integration stands, serve as support for pallets, pallet segments, special structures or flight carriers, racks, and floors during experiment integration and in the early stages of assembly and testing.

3.2.1 EXPERIMENT INTEGRATION STANDS. The experiment integration stands 1 north and 1 south are used in the assembly, disassembly, and functional checkout of experiments on pallets or special structures and within racks. These stands are used with the integration trolleys that support the payload pallets. Several single pallets for one mission can be integrated in one stand. Operations in these stands also include payload component mating, demating, staging, and refurbishing. Access to the payload is from the bay area floor using portable GSE. Figure 3-5 shows the north and south stands.

3.2.1.1 South Stand. The south experiment integration stand (no. 1) is 24.3 m (79 ft) long and 4.1 m (13 ft 7-5/8 in) wide. The stand contains two steel floor-mounted rails 1.2 m (4 ft) high with approximately 54.2 m² (583.9 ft²) of flooring raised 36.8 cm (14-1/2 in) between them on the west end. This raised floor provides for routing of utilities to the payload during experiment integration and can support flight hardware.

3.2.1.2 North Stand. The north workstand (no. 1A) is 28.0 m (91 ft 10 in) long and, like the south stand, is 4.1 m (13 ft 7-5/8 in) wide. Approximately 49.2 m² (529.6 ft²) of raised floor provides for routing of utilities to the payload.

RELEASED

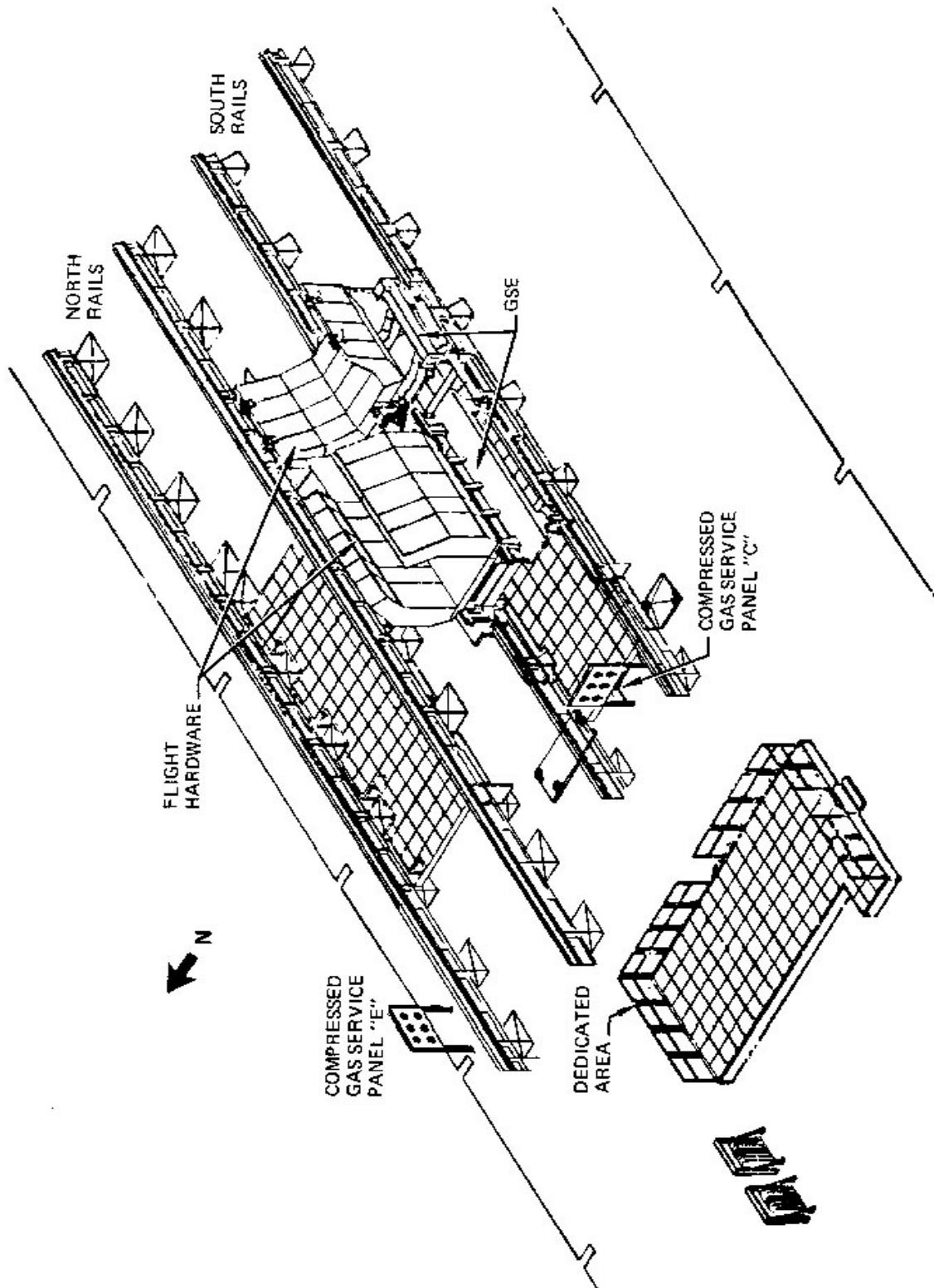

Figure 3-5. North and South Experiment Integration Stands

RELEASED

K-STSM-14.1.14

3.2.1.3 Mechanical. The mechanical equipment, systems, and services available at the experiment integration stands are access platforms, subsystem floor and rack simulator, trunnion support, fluids and gases, and a portable hoist that is shared among the bay area stands (see subsection 3.5.3).

- a. Access Platforms. Individual access platforms for these two workstands are available for use during experiment integration. Figure 3-6 illustrates this access for the pallet and racks in a Spacelab module and pallet configuration. All access equipment at the experiment integration stands is portable to accommodate a variety of payload configurations. Other access equipment for general use in the bay area is presented in subsection 3.5, Portable Access and Handling GSE.
- b. Aft Flight Deck (AFD) Simulator. The AFD simulator racks in the experiment integration area are used in the functional checkout of experiments on pallets and special structures and in racks. One AFD simulator rack is used for the south stand; the other for the north stand. The two AFD simulator racks are located in the dedicated electrical GSE (EGSE) area.
- c. Subsystem Floor and Rack Simulator. The subsystem floor and rack simulator is used in conjunction with all module configurations. It simulates the workbench rack, control center rack, and flooring - all of which stay in the flight core segment of Spacelab. The subsystem floor and rack simulator is shown in figure 3-6. The simulator is positioned on the workstand in the proper X_o , Y_o , and Z_o location in reference to the flight racks and floors.
- d. Trunnion Support. The trunnion support structure (figure 3-7) is used in the experiment integration stands to support one Spacelab or pallet-type structure. It contains fittings to accommodate trunnions as close as 69.9 cm (27.5 in). Deflection restraint devices can be installed in the trunnion support structure.
- e. Handling Fixtures. Special fixtures, or frames, are available for handling sets of racks--six double racks and four single racks. The fixtures are used to install racks on the floor.

RELEASED

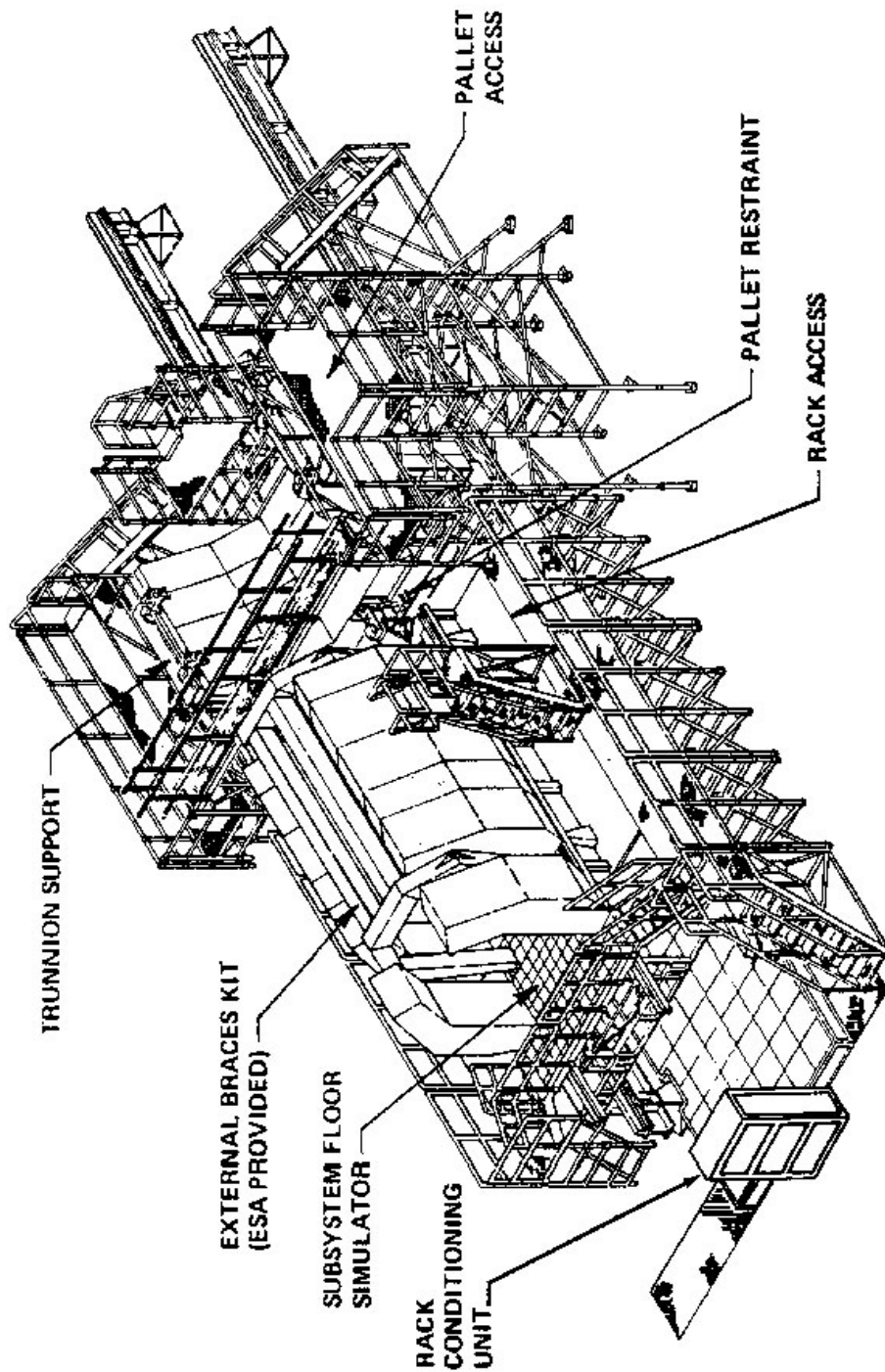

Figure 3-6. Typical Access for Pallet and Racks in the Module-With-Pallet Configuration

RELEASED

K-STSM-14.1.14

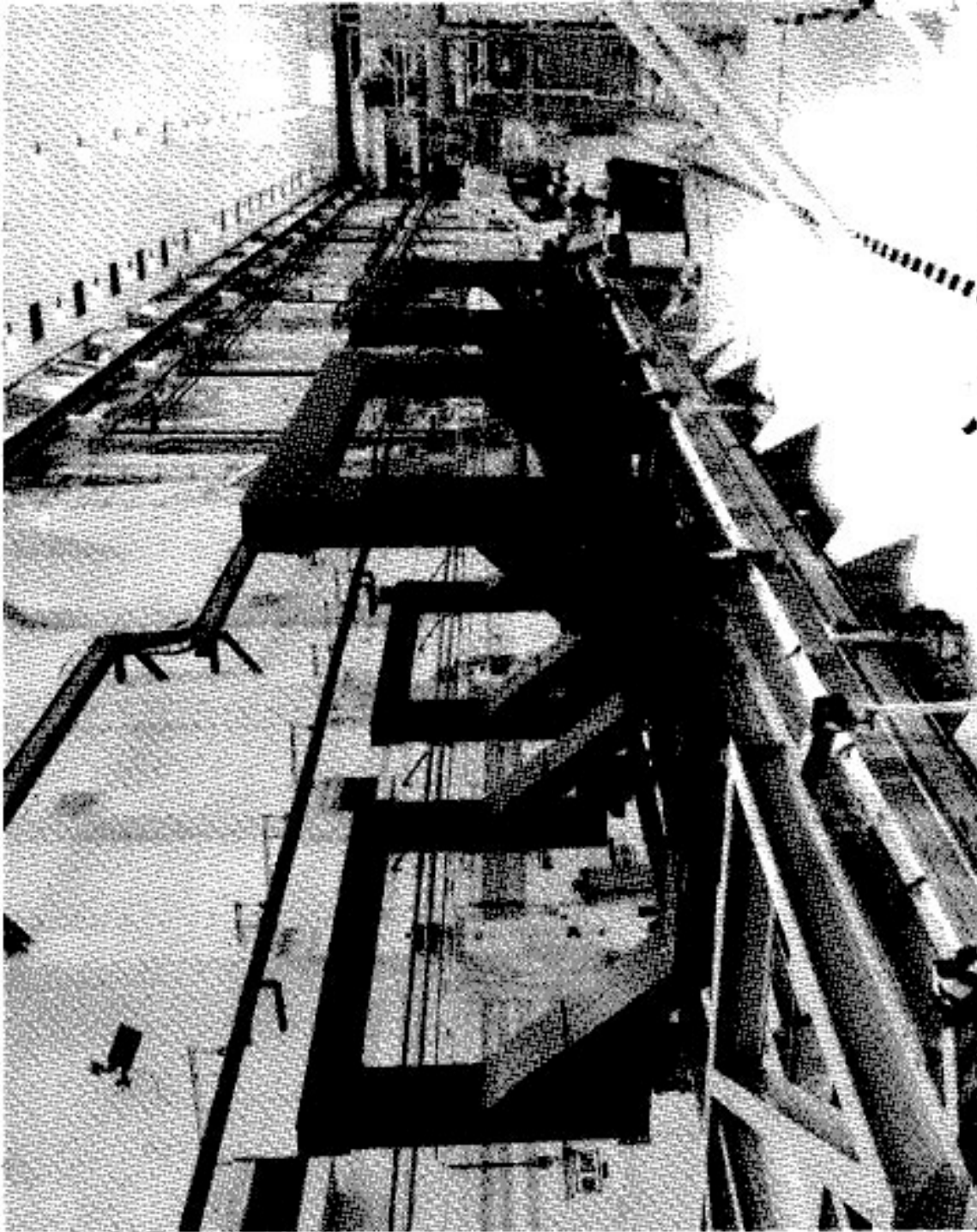

Figure 3-7. Trunnion Support For Experiment Integration

RELEASED

- f. Fluids and Gases. The north and south workstands have several fluids and gases available for the payload user. Table 3-3 contains the fluid and gas information. In addition to those fixed services, several portable servicers are provided. See table 3-4. All pipe terminations at these two stands are male 37 degree tubing connections with KC 150C cap assemblies. See 79K16211 for detailed interfaces. Portable N₂ and He K-bottles can also be used at these workstands.

3.2.1.4 Electrical. The experiment integration stands provide ac power for the payload use. DC power is provided by GSE.

- a. AC Power - AC electrical power provided for GSE is:

Volt (V)	Phase (\emptyset)	Ampere (A)	Hertz (HZ)
120	1	15	60
120	1	20	60
120	1	30	60
120/208	3	30	60
120/208	3	60	60

The ac power receptacles are both rail- and pedestal-mounted, as shown in figure 3-8. The receptacle types and locations on the stands are shown in the standard interface document, 79K16211. AC power of 115-V, 400-Hz is available for flight hardware.

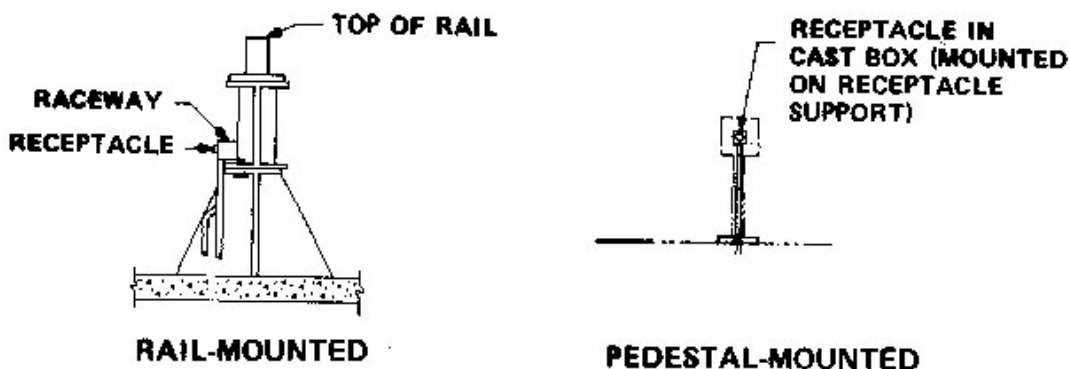

Figure 3-8. Receptacle Mounting Positions on Experiment Integration Stands

- b. DC Power - The 28-Vdc power supplies consist of the Kepco model PPP24-42M (10A), Kepco model PPP28-36M (25A), and the Sorenson model 40-125A (110A). The Kepco units are mounted in standard racks; the Sorenson unit can be freestanding or rack mounted. The Kepco units have rear-mounted output studs that accept a lugged cable. The Sorenson unit output terminal is a Penn Union ZE 34. DC power is available to both flight hardware and GSE, if needed.

K-STSM-14.1.14

Table 3-3. Fluids and Gases, Experiment Integration Stands

Fluid/Gas Supply/Vent & Drain	Operating Pressure bar (lb/in ²)	Temperature degrees C (degrees F)	Valve Size cm (in)	Valve Type	Locations
Potable Water	5.2 (75)	Ambient	1.3 (1/2) 2.5 (1)	Gate (FSWW-V-54)	North 7 South Stands
Chilled Water Supply	6.9 (100)	46 degrees (71.8 degrees)	2.5 (1)	Pressure Relief Circle Seal 500 Series & Ball (Jamesbury FB36TT)	North & South Stands
Return	6.9 (100)	46 degrees (71.8 degrees)	3.2 (1-1/4) 5 (2)	Flow Balancing (Bell & Gossett mod) Gate (FSWW-V-54)	
Compressed Air	8.6 (125)	Ambient	2.5 (1)	Gate (FSWW-V-54)	North & South Stands & Pnl E
GN ₂	27 (390) 83 (1200) 207 (3000)	Ambient	1.3 (1/2) 2.5 (1)	79K80059-2 79K80065-2	Pals A, C, E
GHe	50 (725) 250 (3625)	Ambient	0.6 (1/4)	79K80059-1	Pals A, C, E
Vent (various gases)	0.3 (0-5)	N/A	2.5 (1)	-----	North & South Stands
Drain	0.3 (0-5)	Ambient	2.5 (1)	-----	North & South Stands

RELEASED

Table 3-4. Experiment Integration Stand Servicers

Type	Pressure	Supply Temperature	Flow gal/min	I/F	Remarks
Water Servicer	11.4 bars (165 lb/in ²)	10 degrees C minimum (50 degrees F)	0.06 to 0.25 (1 to 5)	1.9-cm (3/4-in) flexible hose connection	Remove 5 kW from payload
Freon Servicer	13.8 bars (200 lb/in ² max)	10 degrees C (50 degrees F) minimum	0.06 to 0.3 (1 to 5)	1.9-cm (3/4-in) flexible hose connection , ball valve	Remove 7.5 kW from payload
Rack conditioning Unit (ECS)		8.9 degrees-26.7 degrees C (48 degrees-80 degrees F) 60% max RH at 25 degrees C (77 degrees F)	0 to 1007 kg/h 12 to 30 lb/min	10-cm (4-in), 15.2-cm (6-in), and 20.3-cm (8-in)flex duct	10-4 torr; net cooling 29,000 Btu/h 8.5 kW

- c. 50-Hz Power - The stands provide a GSE rack-mounted power unit with 50-Hz, 60-Hz, and 400-Hz; 1-Ø and 3-Ø ; and 12 kVA.
- d. Grounding - Equipment and instrument grounding plates are provided along both stands.
- e. Illumination - There is no special lighting provided for the experiment integration stands. Overhead fixtures in the area provide between 753.5 lm/m² and 1076.4 lm/m² (70 fc and 100 fc).

3.2.1.5 Communications and Data Handling. The capabilities at the experiment integration stands consist of the PCU's and the Partial Payload Checkout Unit (PPCU) (figure 3-9).

The PCUs are used to provide a simulation of the Spacelab Command and Data Management System (CDMS) to the experiments, and allow monitor and control of the EGSE, ECE, or flight hardware. The PCUs can be used independently in support of dual flow processing of Spacelabs in the north and south workstands. The PCU capabilities are presented in more detail in section IV.

The PPCU performs checkout of partial payloads and their carriers located within the Level 4 test stand area of the O&C Building at KSC. The PPCU system is a modular, distributed-processing system consisting mainly of commercially available hardware and software. Custom hardware is required to support the unique interfaces to the payload/carrier and custom software to support specialized processing requirements.

RELEASED

K-STSM-14.1.14

Figure 3-9 shows the various locations of the PPCU equipment in the O&C building.

The equipment is located in three main areas:

- a. The Payload/Carrier and some facility interfaces are contained within the Payload Interface Rack located at the level 4 test stand.
- b. The majority of the system is located in rooms 1289H/1291/1293 of the O&C. Commercial equipment is housed in office-environment type packaging while custom equipment is housed in several standard equipment racks.
- c. Workstations are located in the Cargo user rooms (A, B, and C) on the fourth floor of the O&C building. Figure 3-10 shows the PPCU user room layout.

Several interface panels and the system cabling are located between these areas in the O&C building. Various data cables also terminate in the High Rate Data Equipment (HRDE) room (room 1263) for routing to user selected locations.

More detailed information on the PPCU is available in KSCM-PEDE-0051-O&M, *PPCU System Operations and Maintenance manual*.

RELEASED

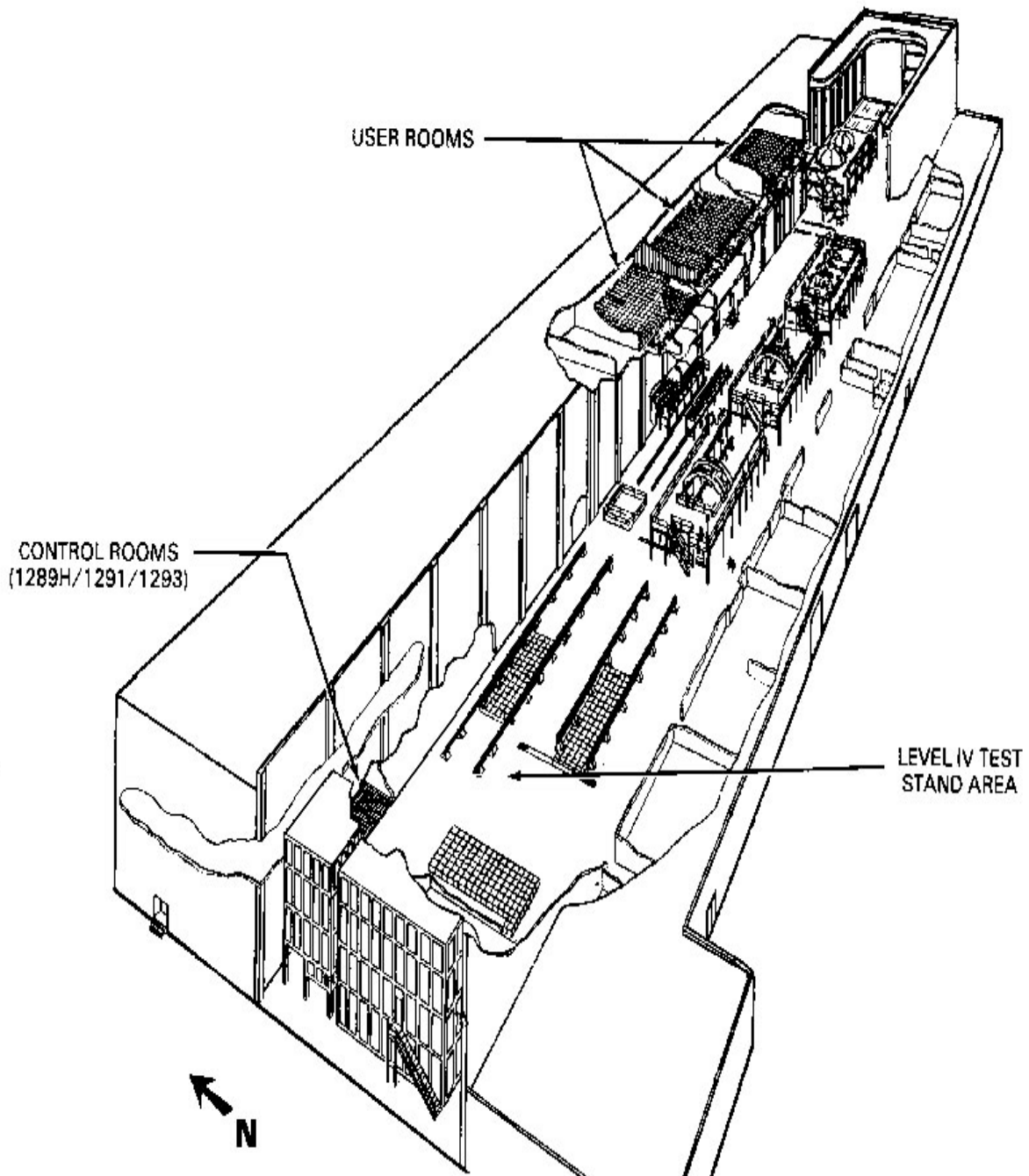

Figure 3-9. PPCU EQUIPMENT LOCATIONS

RELEASED

K-STSM-14.1.14

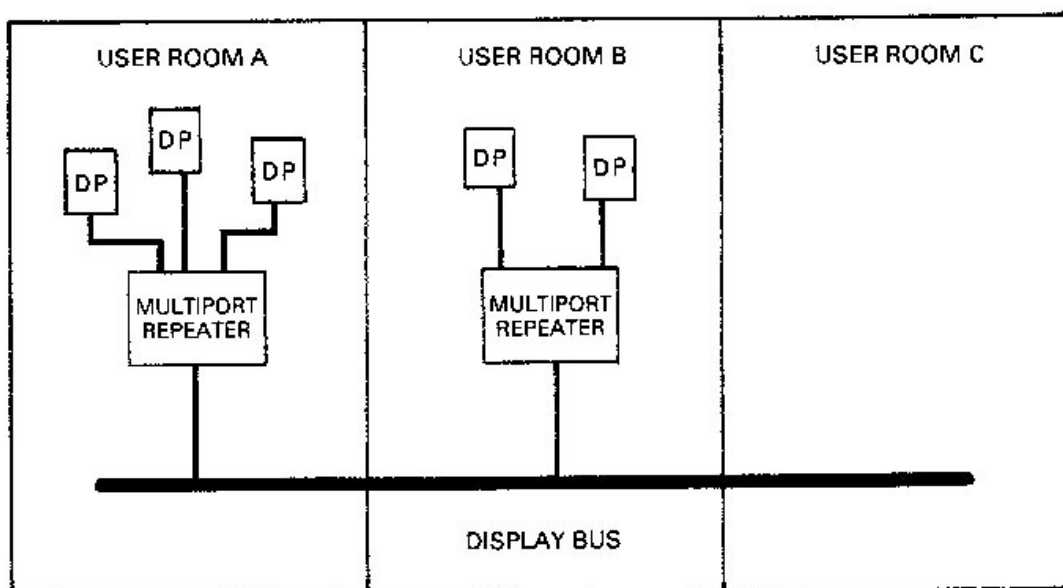

Figure 3-10. PPCU USER ROOMS LAYOUT

3.2.1.6 Electrical GSE (EGSE) Area. The EGSE area is located west of the experiment integration stands next to the ATM clean room. The EGSE area provides approximately 40.1 m² (431 ft²) of 47-cm (18-1/2-in) raised floor in support of dedicated experiment integration activities. The EGSE area contains ac and dc power (including 28-V, 100 and 500-A ac power supply and the 400-Hz power converter), distributors, timing, signal conditioning, control panels, TV, PCU, and associated GSE.

The EGSE area contains the following ac electrical power:

<u>V</u>	<u>∅</u>	<u>A</u>	<u>Hz</u>
120	1	15	60
120	1	20	60
120/208	3	30	60
120/208	3	60	60
277/480	3	30	60
480	3	60	60

RELEASED

AC duplex receptacles are mounted on pedestals 35.6 cm (14 in) above the raised floor on the west side. Four equipment and three instrumentation grounds are available in the area. Fire detection is provided by four underfloor ion detectors, five overhead detectors mounted beneath the clean work area access platform edge, and six detectors mounted on an overhead rail on the east side. The data handling capability of the EGSE is presented in section IV under the appropriate control and monitoring areas.

3.2.1.7 Mechanical GSE (MGSE) Area. The MGSE area is on the west side of the north stand, beside the class 50,000 clean work area. The water and Freon servicers are located there, also. The MGSE area provides ac power as follows:

<u>V</u>	<u>∅</u>	<u>A</u>	<u>Hz</u>
120	1	30	60
120/208	3	30	60
120/208	3	60	60

3.2.2 WORKSTANDS 2 AND 3. These two stands were designed to accommodate buildup of the Spacelab elements into a payload. Because they contain much of the same equipment and services, they are presented together. Figures 3-11 and 3-12 show workstands 2 and 3.

Each stand is 24.9 m (82 ft) long and 10.1 m (33 ft) wide. Access to the periphery of the payload is provided by the walkway around the stand on the north, west, and south. This walkway is elevated 3.3 m (10 ft 10 in) above the area floor and is 1.8 m (6 ft) wide on the north and south and 3.6 m (12 ft) wide on the west side. This walkway has a Zo 400 reference. Removable posts and chains separate the walkway from the fixed rails. The basic workstand deck for these stands is identical to the CITE stand (subsection 3.2.3).

3.2.2.1 Mechanical. These workstands provide hoisting equipment, access platforms, fluids, and gases.

- a. Jib Crane. There is one electric motor-operated jib crane on workstand #3 (Southwest corner). This 0.9-metric ton (1-ton) capacity jib is used for hoisting or lowering loads between the area floor and the deck of the stand. The jib has a boom rail length of 3.1 m (10 ft) at a height of 3.1 m (10 ft) above the workstand deck. This crane has a multiposition locking device for twelve position lock points 30 degrees apart. The hook lift distance for the jib is 6.7 m (22 ft) above the floor. The hook dimensions are shown in 79K16211. .

RELEASED

K-STSM-14.1.14

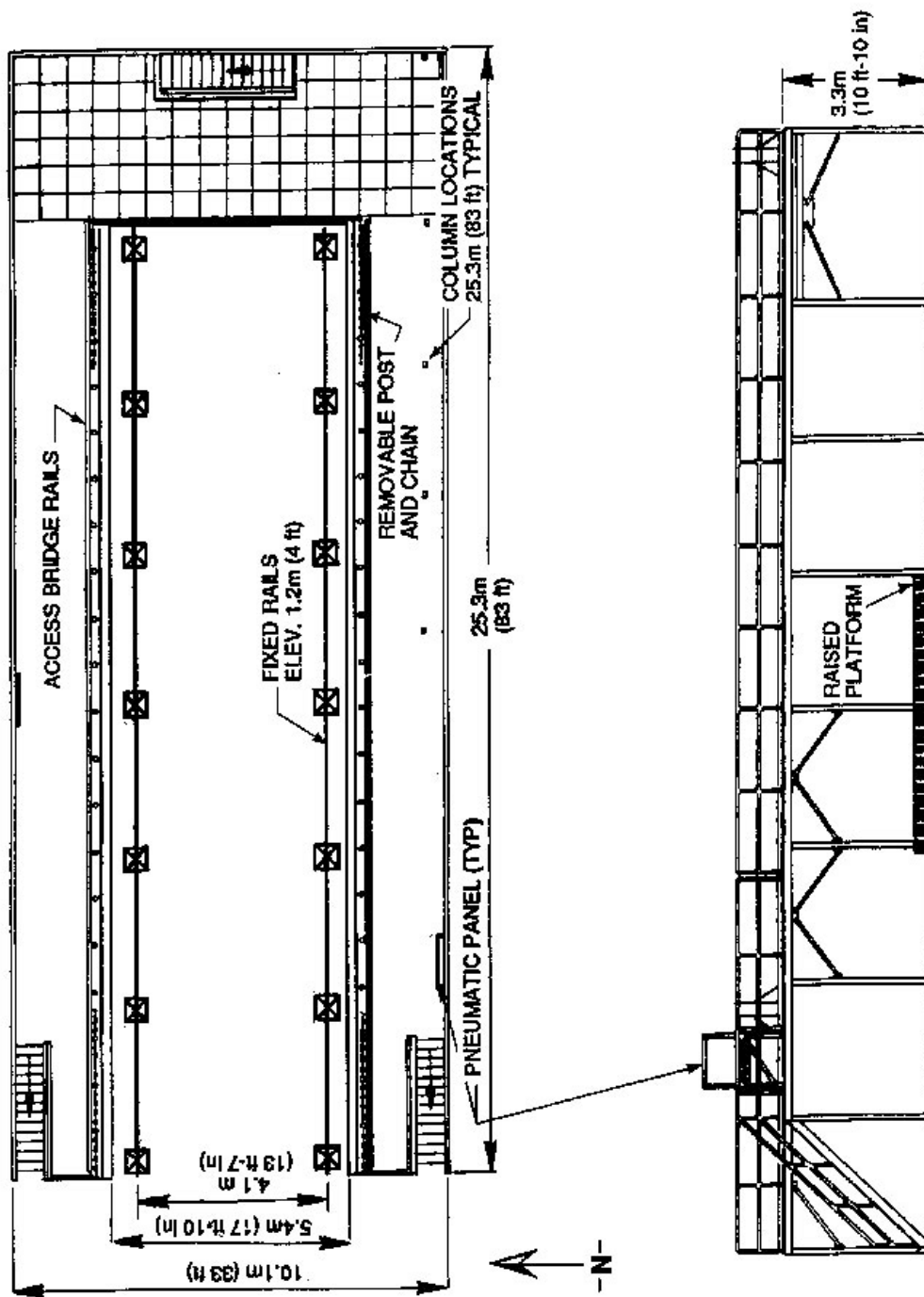

Figure 3-11. Workstands 2 and 3, Plan View and Elevation

RELEASED

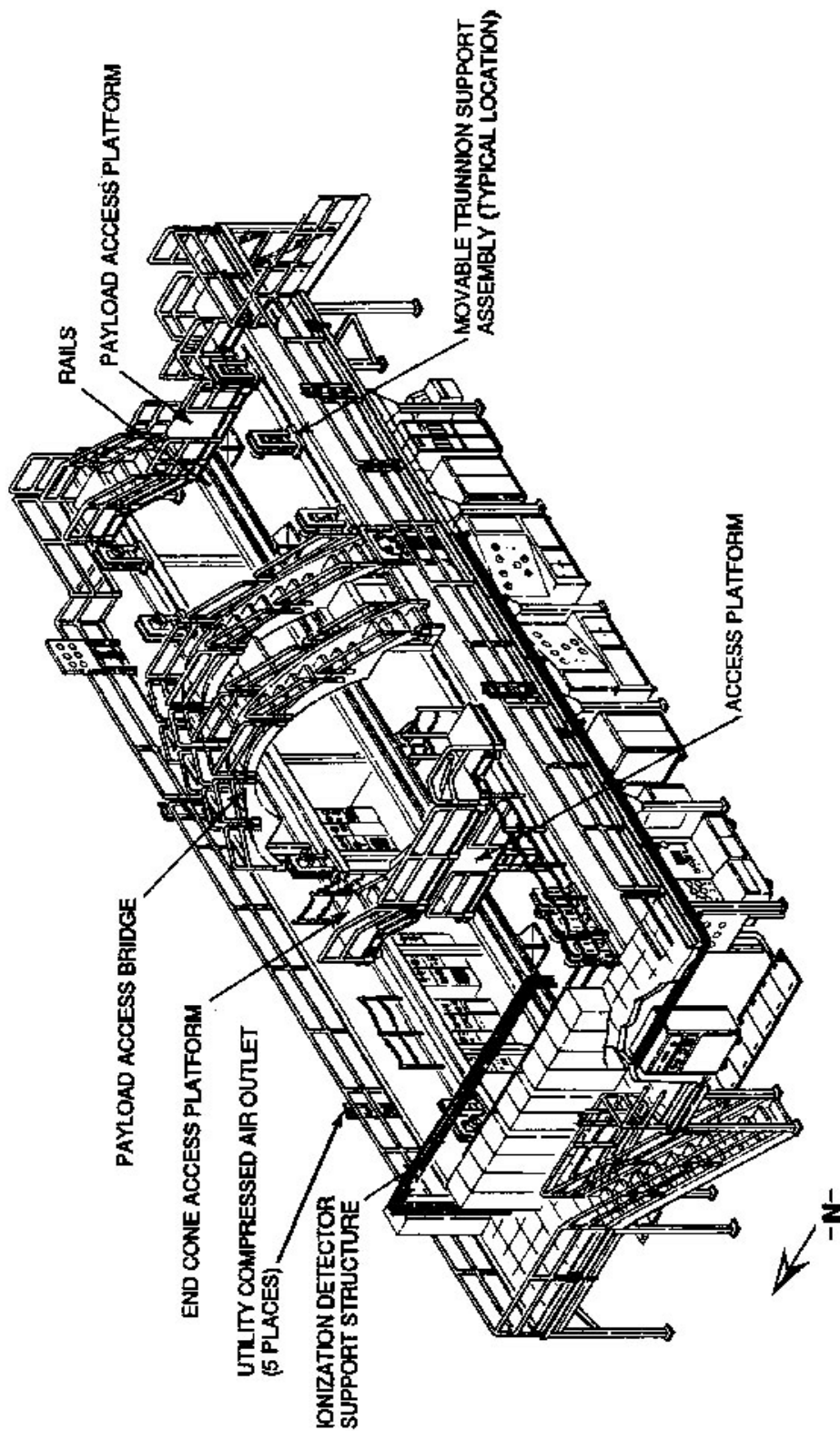

Figure 3-12. Workstands 2 and 3, Equipment Locations

RELEASED

K-STSM-14.1.14

- b. Access Platforms. One overhead bridge access platform is provided for use on stand 2 and 3. A second stand is modified for use only on the mideast rails. The platforms provide access around the upper half of the Spacelab module. See figure 3-13. The overhead bridge is rail mounted and can be located in any X_o position within the workstand.

Each stand is provided with a forward end cone and tunnel hatch access platform (figure 3-14) and a pallet access platform (figure 3-15). Both of these platforms are rail mounted and can be located in any X_o position within the workstand. These platforms also have lifting eyes that permit interchange between stands. Figure 3-16 shows the three platforms in use on stand 2 or 3.

- c. Fluids and Gases. These two stands provide fluids and gases (GHe, GN_2 , and compressed air) for use by the payload. Table 3-5 presents the workstand 2 and 3 fluids and gases. Document 79K16211 locates these services on the workstands. All fittings on these panels are KC124C4 or KC124C8.
- d. Payload Instrumentation GSE (IGSE) Area. There is a 6.1 m (20 ft) area on the floor level of the northeast corner of each workstand that has been dedicated to payload IGSE.
- e. Trunnion Support Assemblies. There are 12 payload trunnion support assemblies (six on each north and south side) provided on each of workstands 2 and 3. These assemblies are movable as required along the X_o axis and adjustable along the Y_o and Z_o axes. Details of a support assembly are shown in 79K16211.

RELEASED

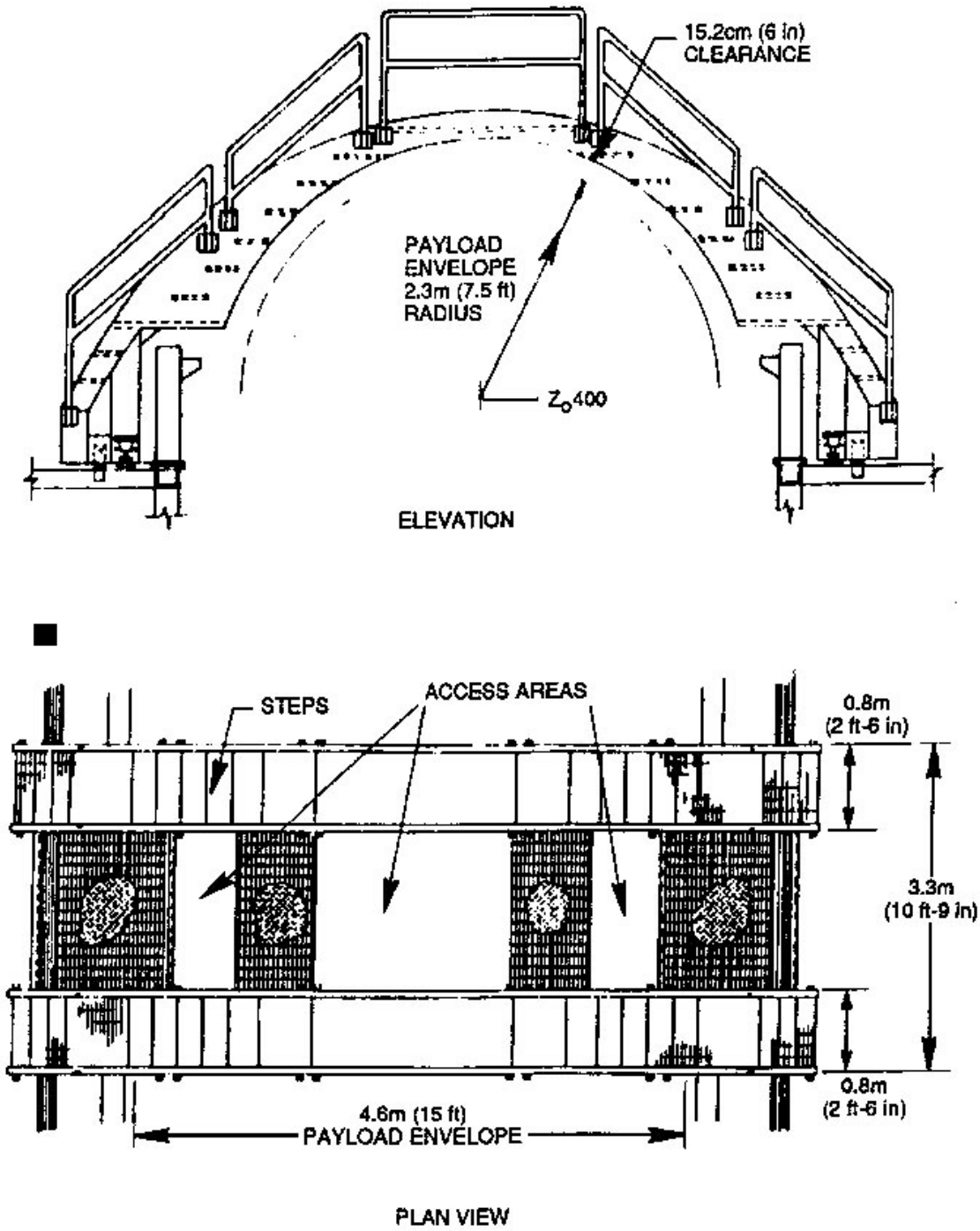

Figure 3-13. Overhead Bridge Access Platform Workstands 2 and 3

RELEASED

K-STSM-14.1.14

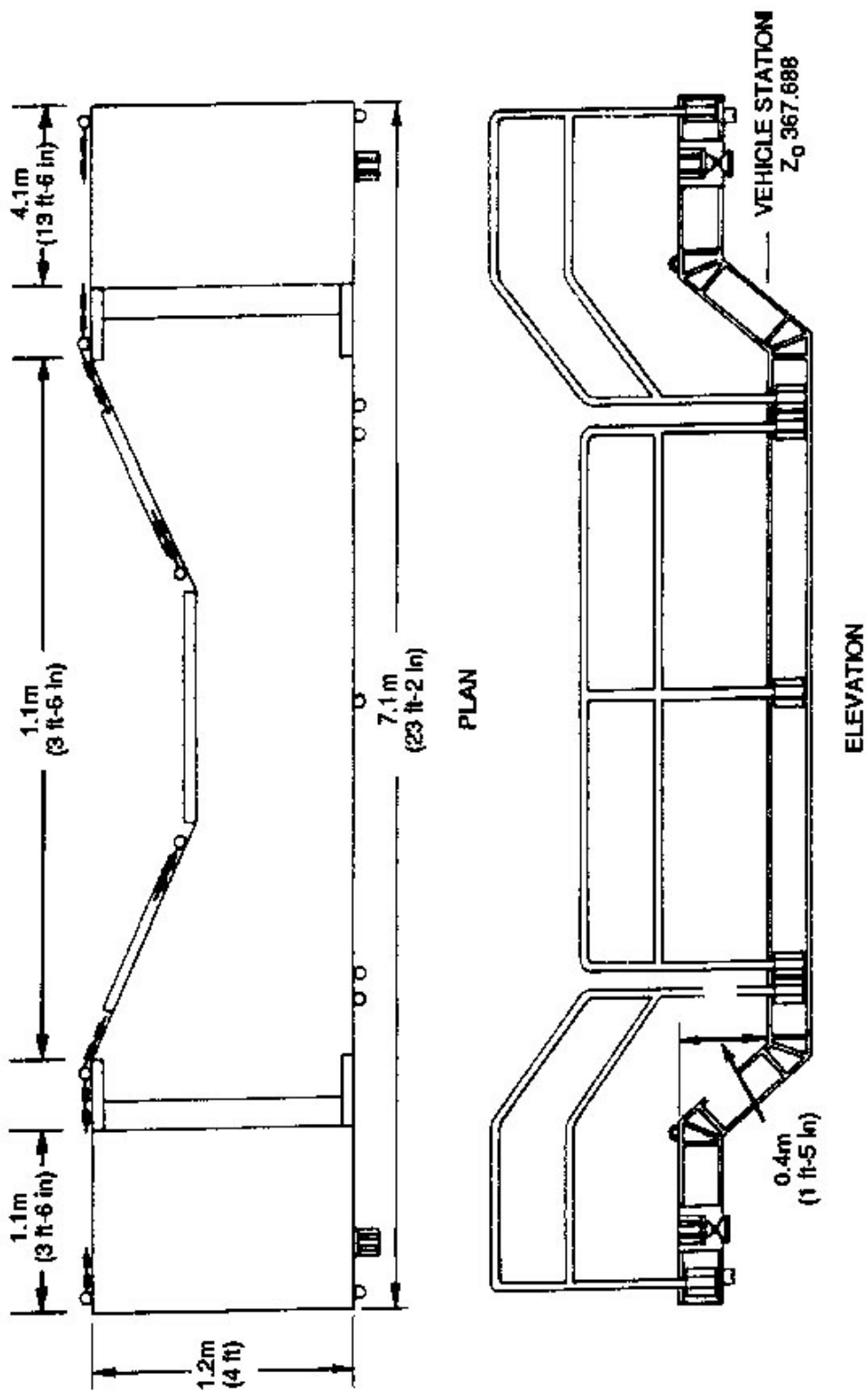

Figure 3-14. Forward End Cone/Tunnel Hatch Access Platform

RELEASED

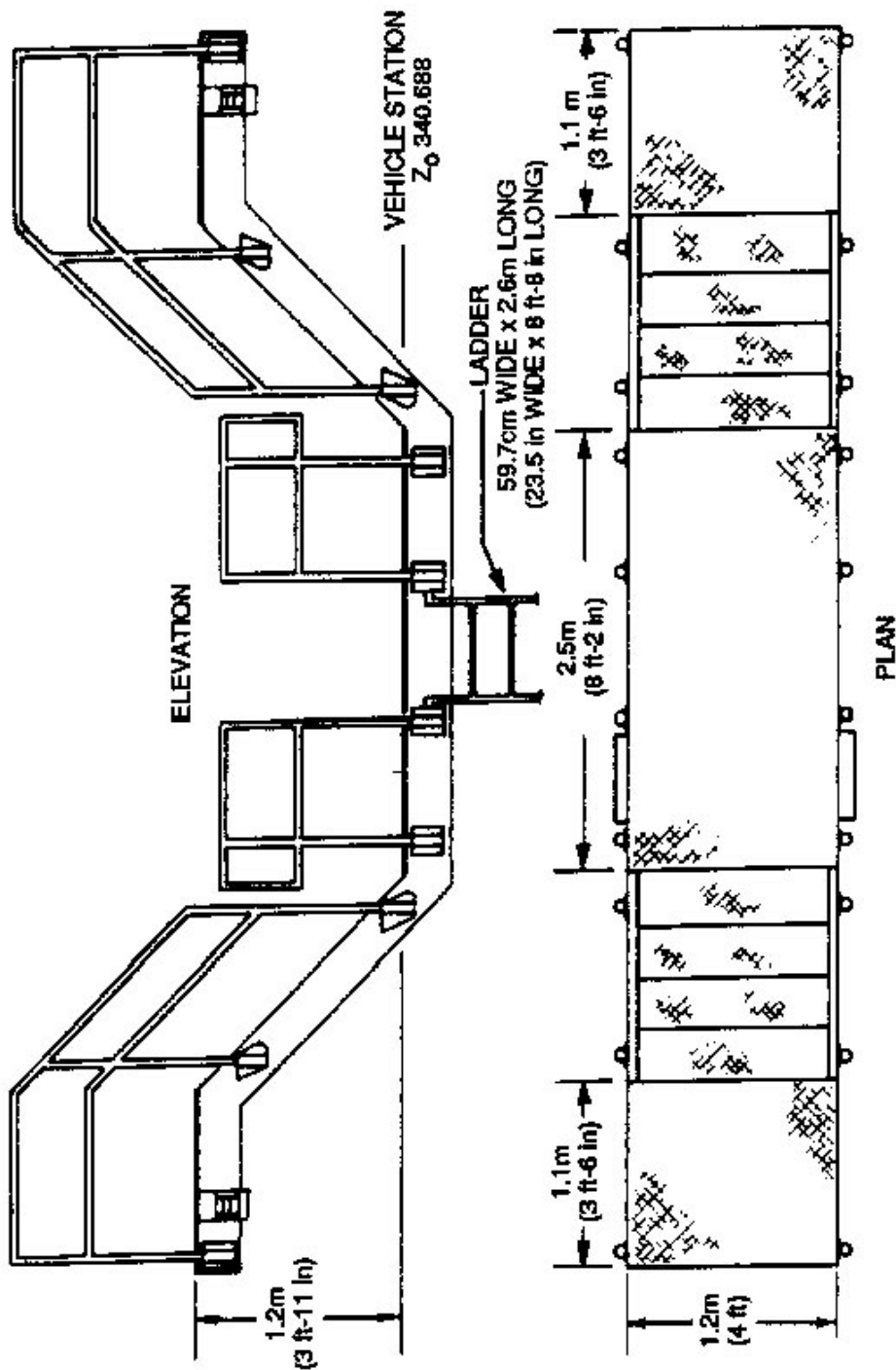
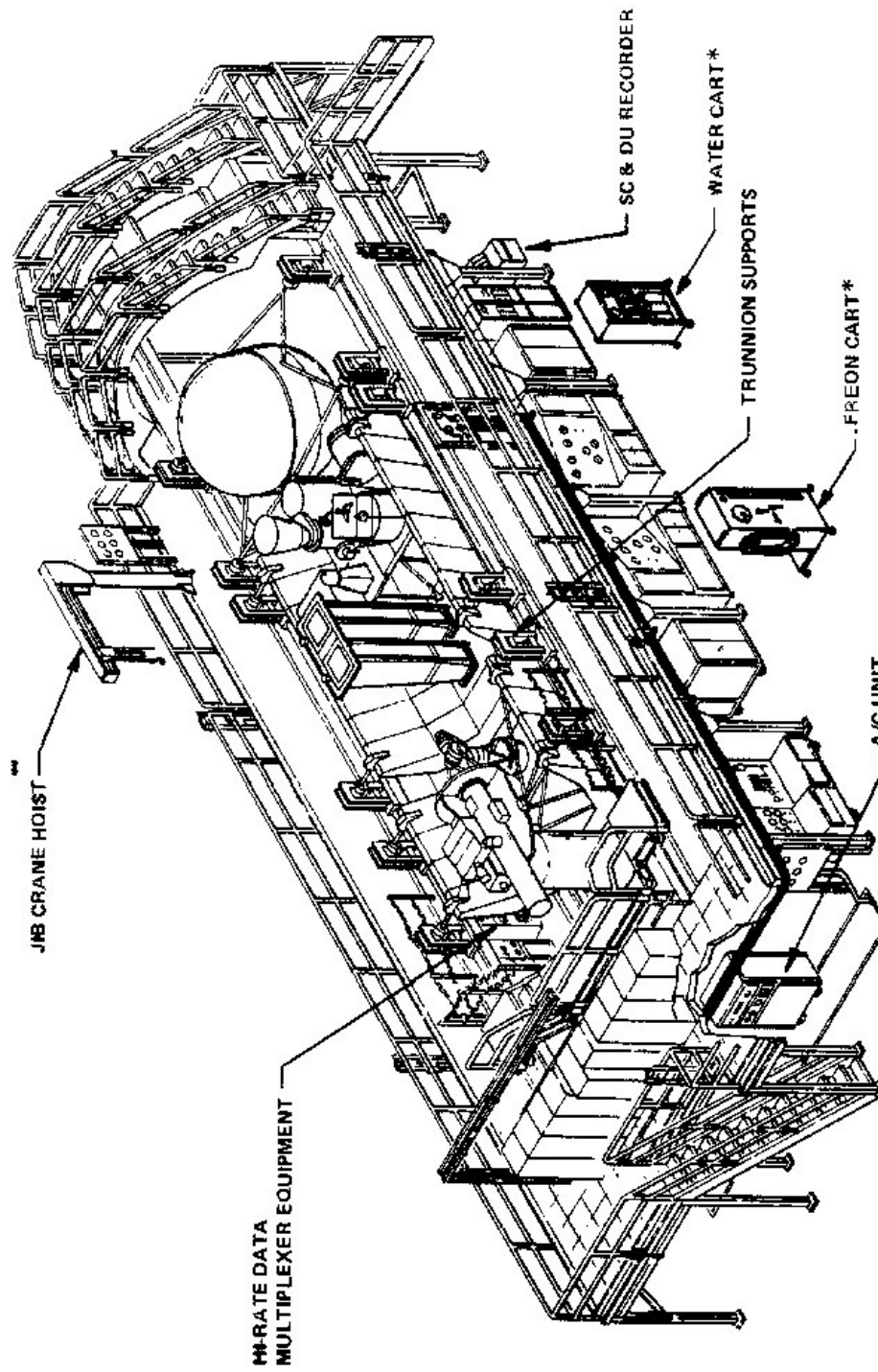

Figure 3-15. Pallet Access Platform

RELEASED

K-STSM-14.1.14



* PORTABLE UNITS
 **STAND 3 SOUTHWEST CORNER ONLY

Figure 3-16. Spacelab 2 in Workstand 3

RELEASED

Table 3-5. Fluids and Gases, Workstands 2 and 3*

Fluid/Gas	Pressure bar (lb/in ²)	Fitting Interface cm (in)	Location
GHe	250 (3625) 50 (725)	1.9 (3/4) KC124C4 1.3 (1/2) KC12f4C4	Panels A, C, and D
GN ₂	207 (3000) 83 (1200) 27 (390)	1.3 (1/2) KC 124 C4 1.9 (3/4) KC124C4 1.2 (1/2) KC124C8	Panels A, C, and D
Comp Air (Regulated)	9 (125)	5.1 (2) 2.5 (1) Hansen 1.3 (1/2) Series 4000	Five Stations each stand

* Detailed interfaces are shown in 79K16211

3.2.2.2 Electrical. Workstands 2 and 3 provide ac power for payload use. DC power is provided by GSE.

a. AC Power.

<u>V</u>	<u>∅</u>	<u>A</u>	<u>Hz</u>
120	1	15	60
120	1	20	60
120/208	3	30	60
120/208	3	60	60

In addition, workstand 2 contains a 120/208-V, 3-∅, 60-A, 60-Hz power converter outlet for use by the 50-Hz power unit described in 3.2.1.4c.

The ac power receptacles are both rail and pedestal mounted. Refer to figure 3-8.

- b. DC Power. DC power is provided by ESA's Spacelab Payload Command and Data System (SPCDS) for Spacelab payloads and the equipment provided for experiment integration (see 3.2.1.4b).
- c. Raised Platform. On the north side under each stand is 30.5 cm (12 in) raised platform 9.1 m (30 ft) long by 2.1 m (6 ft 8 in) wide dedicated for Spacelab system GSE.
- d. Grounding. Grounding for equipment and instrumentation is provided as stated in 3.1.7.

RELEASED

K-STSM-14.1.14

3.2.2.3 Communications and Data Handling. Workstands 2 and 3 contain portions of the automatic test equipment (ATE) used for Spacelab detailed verification and diagnostic testing, real-time telemetry processing, data display, test sequencing, control and command generation, timing, rapid fault-finding, and signal routing. It includes the required operational and diagnostic software necessary to fulfill operational and self-testing requirements. The ground power unit and the orbiter interface adapter provide power to Spacelab during the test phases before orbiter-Spacelab mating, and simulate the electrical functions of the orbiter-to-Spacelab interface, respectively. The remaining portions of the ATE are located in a control room remote from the workstands. These rooms are presented in section IV, Control and Monitoring Areas.

3.2.3 CITE STAND. Workstand 4, the CITE stand, simulates the orbiter electrical accommodations for all payload interfaces. The CITE is used to verify compatibility between payloads and the simulated orbiter electrical and electronic interfaces. Figures 3-17 and 3-18 show the CITE stand and its equipment. Closed-loop Payload Operations Control Center (POCC) interface tests, when required by the payload, are conducted with the payload in this stand.

CITE testing will include an interface verification test, a mission-sequence test (if appropriate), required payload element tests, and operations to validate planned on-line pre- and postflight operations including emergency, contingency, and scrub and turnaround procedures. A time-compressed mission sequence test will be included when it is judged to be an effective demonstration of multiple system compatibility, either payload-to-payload or payload-to-orbiter. During CITE testing, participation will include payload and carrier owners and flight crewmembers. A block of serial time is provided for payload-peculiar operations.

3.2.3.1 Mechanical. The mechanical equipment located on this stand includes an AFD structure, a forward orbiter bulkhead assembly, an aft bulkhead, orbiter simulated cable trays, fluid lines, and a midbody assembly. Openings are provided to duplicate orbiter access hatches. The workstand deck is established 3.3 m (10 ft 10 in) above the bay area floor at orbiter station elevation Zo 400. The deck provides basic access to the payload in the CITE stand. The work platform deck on the north and south is designed for uniform loading of 8.8 kg/cm^2 (125 lb/in^2). The AFD decking is designed to support uniform loading of 17.5 kg/cm^2 (250 lb/in^2).

- a. **AFD Simulator.** This simulator provides a working platform and support for a Payload Specialist Station (PSS), an On-Orbit Station (OOS), and a Mission Specialist Station (MSS). Space is available for mission-peculiar consoles and electrical interface panels. Cool air is provided to the AFD modules through 6.4-cm (2-1/2-in) ducting. Rockwell International (RI) receptacles (RI part no. DMMD 122-0012-0004) or equivalent payload-provided receptacles will be used for installing the payload panels. T-handles are used for the smaller panel sizes, and a single handle for each panel over 35.6 cm (14 in) long.

In the OOS, there is space for two payload-dedicated modules. In the PSS, six panels are payload dedicated. In the MSS, three panels are available for the payload. See 79K16211 for the AFD simulator interface details.

RELEASED

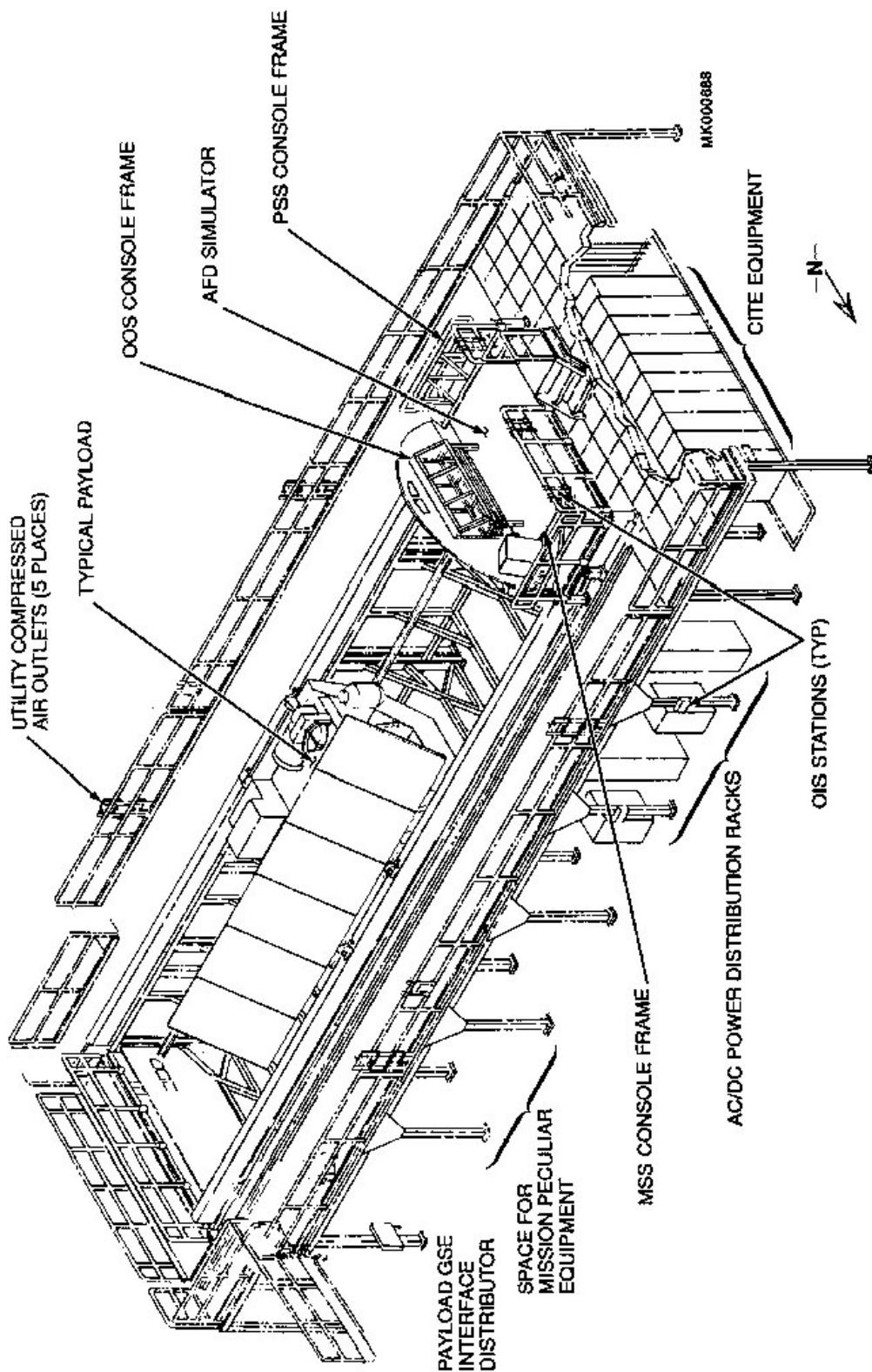

Figure 3-17. CITE Stand, View from the North

RELEASED

K-STSM-14.1.14

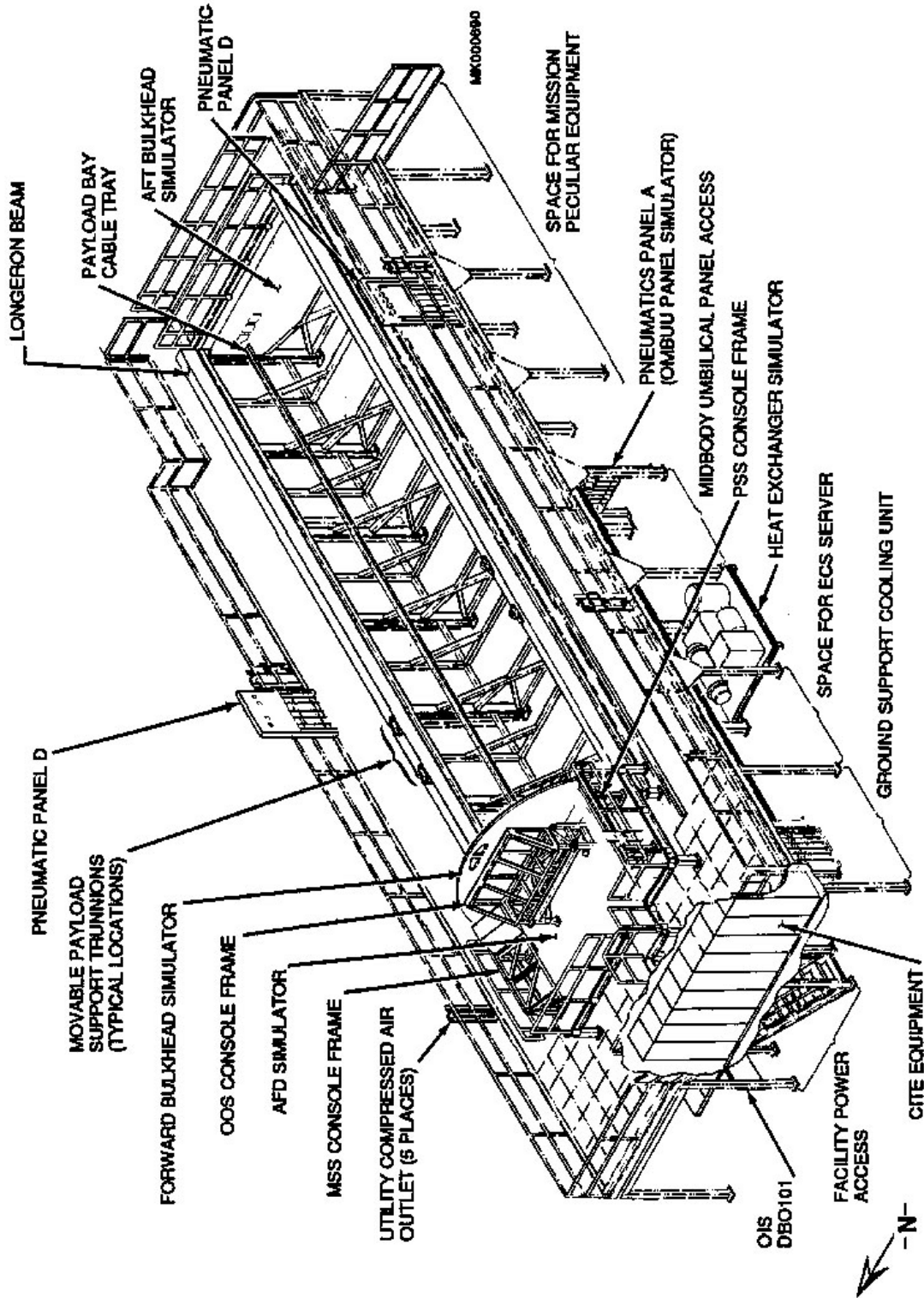

Figure 3-18. CITE Stand, View from the South

RELEASED

- b. Heat Exchanger. The CITE heat exchanger is located on the south side of the CITE stand next to the AFD simulator. It uses KSC facility chilled water to provide payload cooling. An interface panel is provided for two supply and return coolant passage lines from the heat exchanger to the payload interface panel and connections for water and Freon supply lines. Inlet temperature is 1.7 degrees C to 7.2 degrees C (35 degrees F to 45 degrees F), and the exchanger is able to reject a maximum of 29,000 Btu heat load. Flexhoses 1.9 cm (3/4 in) wide, from 66 cm to 243 cm (30 in to 96 in) long interconnect the heat exchanger simulator and the payload.
- c. Payload Support Fitting. The CITE stand provides payload support fittings on each side that can be adjusted along the stand rails to accommodate the payload trunnions. They provide the same interface as the trunnion support structures described in 3.2.1.3d. See 79K16211 for details.
- d. Fluids and Gases. The only fluid provided to the CITE stand is facility chilled water through the water servicer or with the heat exchanger. Gases are provided by pneumatics panels and compressed air stations. Panel A (located at the bay area floor level) contains GN2 at 27, 83, and 207 bars (391, 1200, and 3000 lb/in²) and GHe at 50 and 250 bars (725 and 3625 lb/in²). Compressed air at 9 bars (125 lb/in²) is available at the CITE stand in five places.

3.2.3.2 Electrical. The CITE stand provides ac and dc power for the payload use. 28-V dc power is provided by GSE.

- a. AC Power.

<u>V</u>	<u>∅</u>	<u>A</u>	<u>Hz</u>
120	1	20	60
120	1	30	60
120/208	3	30	60
120/208	3	60	60
480	3	200	60

The ac power receptacles are mounted both on the access deck and beneath the CITE stand accessible from the area floor.

Receptacles are mounted under the CITE stand walkway and on the sides of the stand either 1.2 m (4 ft) or 1.8 m (6 ft) above the ground floor. Types and locations of receptacles are identified in 79K16211.

RELEASED

K-STSM-14.1.14

- b. DC Power. There is a rack for dc power distribution. The Sorenson units and the Kepco unit described in 3.2.1.4b also provide dc power.
- c. AFD Electrical Distribution Panels. The electrical distribution panels are available for payload use at the MSS, OOS, and PSS. Details on the panels are shown in 79K16211.
- d. Grounding. Instrumentation and equipment grounding is provided at the CITE stand. 79K16211 contains details.
- e. Lighting. The CITE stand contains both 150-W incandescent lamps with 35.6 cm (14 in) diameter porcelain reflectors and 40-W fluorescent fixtures under the access deck level.

3.2.3.3 Communications and Data Handling. The payload-to-orbiter interfaces verified in CITE are:

- a. scientific data
- b. launch data bus
- c. pulse code modulator master unit (PCMMU) data bus
- d. payload data bus
- e. payload interrogator
- f. payload data interleaver
- g. multiplexer/demultiplexer
- h. caution and warning
- i. payload safing
- j. payload unique signals
- k. Xo 1307/GSE signals
- l. timing signals
- m. AFD ac and dc power
- n. Xo 1307 dc power
- o. Xo 645 dc power

The CITE functional equipment located on the floor under the CITE stand on the west end consists of wideband terminal distribution, video and data assembly, hardware interface modules (HIMs) and patch panel, interface terminal distributor, dc power

RELEASED

suppliers and distribution, ac power distribution, RF test set, GSE interface distribution, and the CITE test set. More information on this equipment is contained in KCS-HB-0003.0, *Cargo Integration User Handbook*, and in K-STSM-14.1, *Launch Site Accommodations Handbook for Payloads* (section IV).

Additional CITE equipment is located in the CITE control room, which is presented in section IV, Control and Monitoring Areas.

3.2.4 RACK, FLOOR, AND PALLET STAND. The Spacelab rack, floor, and pallet stand (also called the Mideast stand) is located along the north low bay wall. It is 4.2 m (13 ft 10 in) wide by 33.4 m (109 ft 7.5 in) long and contains floor-mounted rails. The stand can accommodate configurations of various combinations of single and double electrical rack buildups that house the payload experiments. It can also accommodate pallets on the integration trolley. This stand allows the use of the overhead bridge, end cone, and tunnel hatch access platforms, as well as the pallet access platform, from stands 2 and 3. Access to the payload in this stand is gained from the floor and the various platforms, as well as through the module access and pallet platform. Details on the module access and pallet platform are shown in 79K29244 and 79K29245, respectively.

3.2.4.1 Electrical. 110-V, 1- \emptyset ac power is available at the rack stand from six pedestal-mounted receptacles - three on each side of the rails. 120/208-V, 3- \emptyset power is found on the wall northeast of the stand.

3.2.4.2 Gases. Panel E, located at the northwest end of the stand, provides compressed air (9 bars), GN2 (27 bars), and GHe (50 bars).

3.2.5 END CONE STANDS. An area 3.1 m by 4.9 m (10 ft by 16 ft) is available north of the CITE stand for storage of the Spacelab module end cones. See figure 3-2.

3.3 OTHER AREAS

3.3.1 HORIZONTAL SLING KIT. The sling kit for Spacelab is stored on top of the altitude chambers on the north side of the high bay.

3.3.2 IGLOO WORK AREAS. North of the CITE stand is a 15.9 m² (160 ft²) space for work on the Spacelab igloo. Portable servicing equipment may be used in this area. In the high bay east of the CITE stand is a 6.1 m by 12.2 m (20 ft by 40 ft) area used for maintenance of the Spacelab transfer tunnel. Refer to figure 3-2 for locations.

3.3.3 STAGING AND ASSEMBLY AREAS. There are three processing areas on the south side of the bay area, east of Receiving and Inspection (room 1469), that are used for staging and mechanical assembly of payloads. The three areas contain approximately 929.0 m² (10,000 ft²). These areas are not served by the bay area bridge cranes, so flight hardware and GSE are moved by means of the air-bearing pallet system described in 3.1.10. See Figure 3-19.

RELEASED

K-STSM-14.1.14

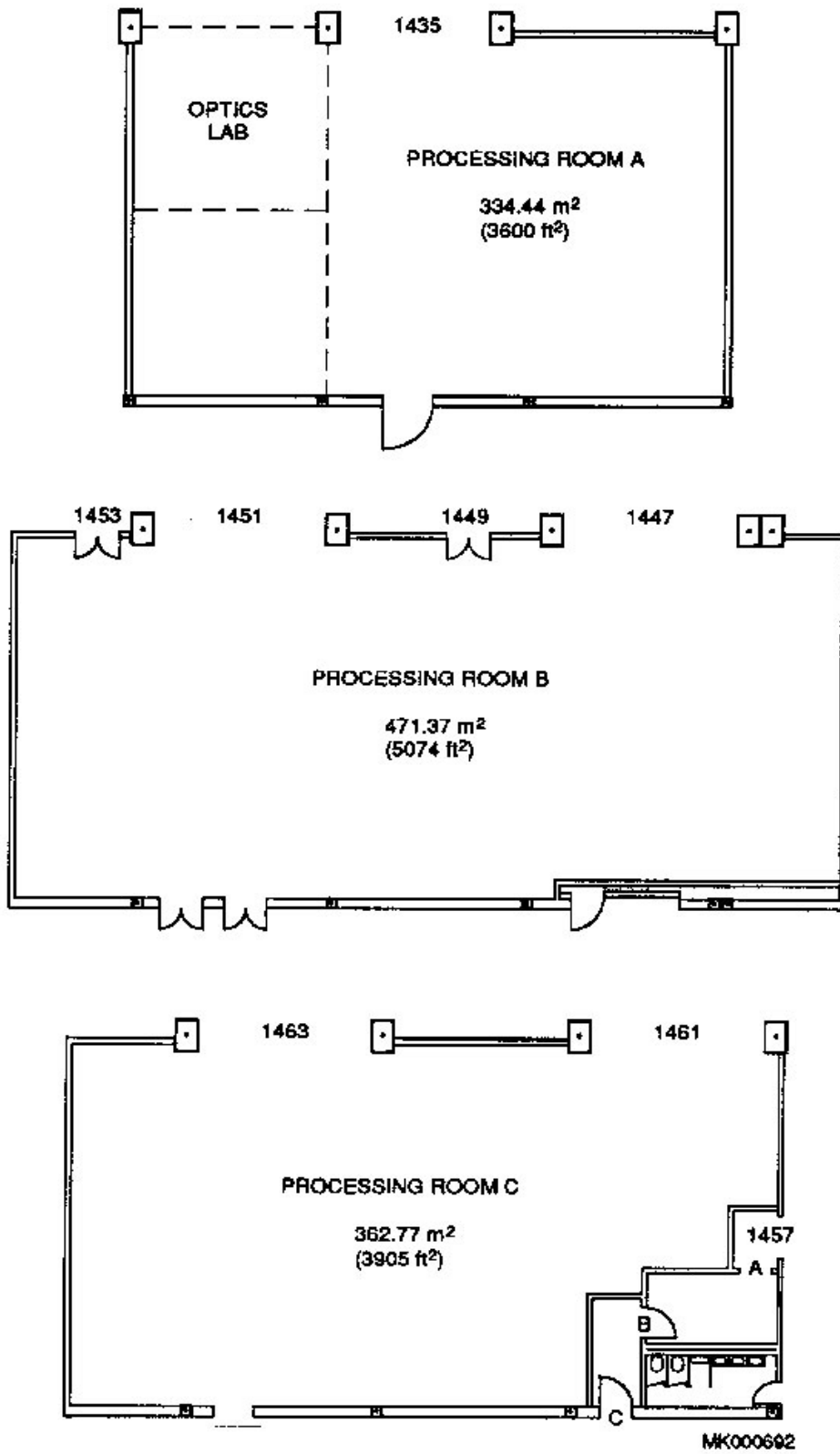

Figure 3-19. Sealing and Assembly Areas

3.4 APOLLO TELESCOPE MOUNT ROOM (ATM) CLASS 10,000 CLEAN WORK AREA

3.4.1 DESCRIPTION. The clean work area located at the west end of the area can be used for off-line experiment integration. The clean work area (figure 3-20) is a two-level structure 11.1 m by 11.2 m (36 ft 8 in by 36 ft 10 in) by 11.6 m (38 ft) high that can be maintained in accordance with class 10,000 clean work area conditions per K-STSM-14.2.1. The second level floor is made up of a grid of porous 0.6 m by 0.6 m (2 ft by 2 ft) aluminum panels at an elevation of 3.2 m (10 ft 6 in). By removing selected panels, a 4.7 m by 2.8 m (15 ft 6 in by 9 ft 3 in) opening provides access between the first level ante-room to the second level. On the first level there is a 6.3 m by 4.6 m (20 ft 8 in by 14 ft 11 in) ante-room. The ante-room serves as an airlock entry area for equipment being brought into the actuated clean work area.

A 3.7 m by 4 m (12 ft 5 in by 13 ft 2 in) seismic pad is on the first level located approximately beneath the opening. This clean work area has sound-absorbing wall panels.

3.4.2 ACCESS. The front panel of this work area on the second level, at an elevation of 3.2 m (10 ft 6 in), opens to provide a 6.1 m (20 ft) wide by 7.3 m (24 ft) high opening. See figures 3-20 and 3-21. This pneumatic door can be opened in a minimum of 1 min and in a maximum of 5 min. Movable panels in the front top wall and the roof open to provide access for the area low bay 24.9 metric ton (27.5-ton) bridge crane. A 4.5-metric ton (5-ton) bridge crane traverses the clean area to within 1.2 m (4 ft) of the walls. The hook height of this crane is 6.2 m (22 ft 9 in) above the removable floor panels and 10.4 m (34 ft) above the O&C Building floor. The ceiling height of the clean area is 11.6 m (38 ft). A personnel air shower 7.8 cm (3 ft 1.5 in) wide, located inside the access room, is provided for entrance into the clean work area.

3.4.3 LIGHTING. The clean work area on the second level has 12 single light fixtures providing 70 foot candles of illumination. The air lock has 3 two-light 40W ceiling mounted fluorescent fixtures with radio frequency interference (RFI) suppressing lenses and an RFI suppressing line filter, and the return air area has 20 two-light 40W fluorescent fixtures with RFI suppressing capabilities.

3.4.4 VACUUM EQUIPMENT. The clean work area vacuum system outlets are located on the first and second levels as well as in the change area of the class 50,000 clean work area.

3.4.5 AIR-CONDITIONING. The area temperature and relative humidity (RH) as shown in table 3-1 are available as a standard service in the clean work area. If requested, the clean area air-conditioning can be activated as an optional service. This air-conditioning consists of high efficiency particle accumulator (HEPA) filter diffusers, 25.4 cm (10 in) flexible ducts handling 188.8 1/s (400 ft³/min) and 377.6 1/s (800 ft³/min), a dehumidifier to handle 5192 1/s (11,000 ft³/min) at a dewpoint of 9.4 degrees C (49 degrees F), two 2-hp chilled water pumps, three vane-axial fans, and two centrifugal fans. Temperature can be maintained at a nominal 72 degrees F (22.2 degrees C) and RH at 50% if the air-conditioning system is activated.

3.4.6 ELECTRICAL POWER. The clean work area has 120-V, 15-A and 30-A duplex receptacles on the wall 45.7 cm (18 in) above the ground floor and the working platform.

RELEASED

K-STSM-14.1.14

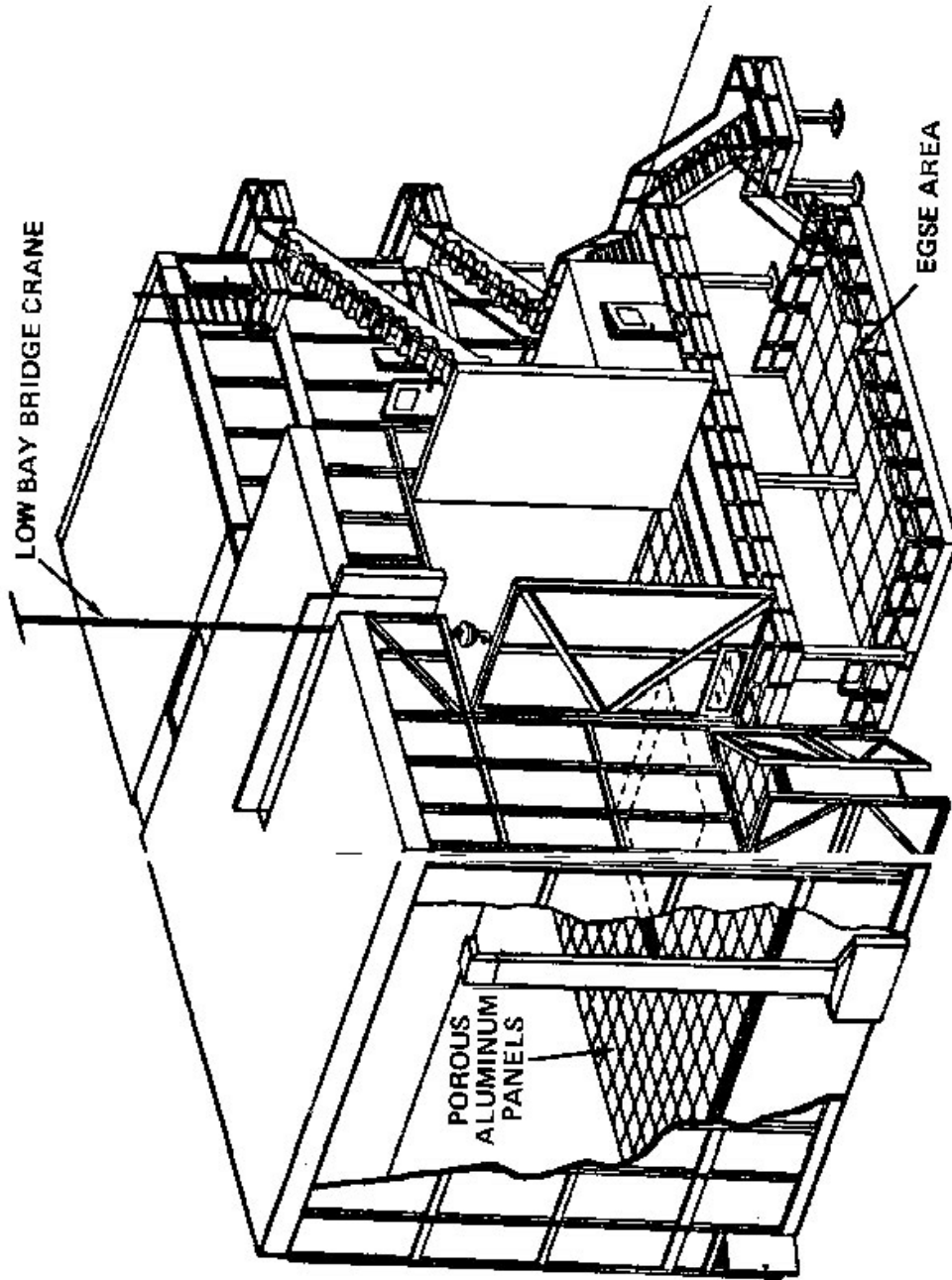

Figure 1-20. Class 10,000 Clean Work Area

RELEASED

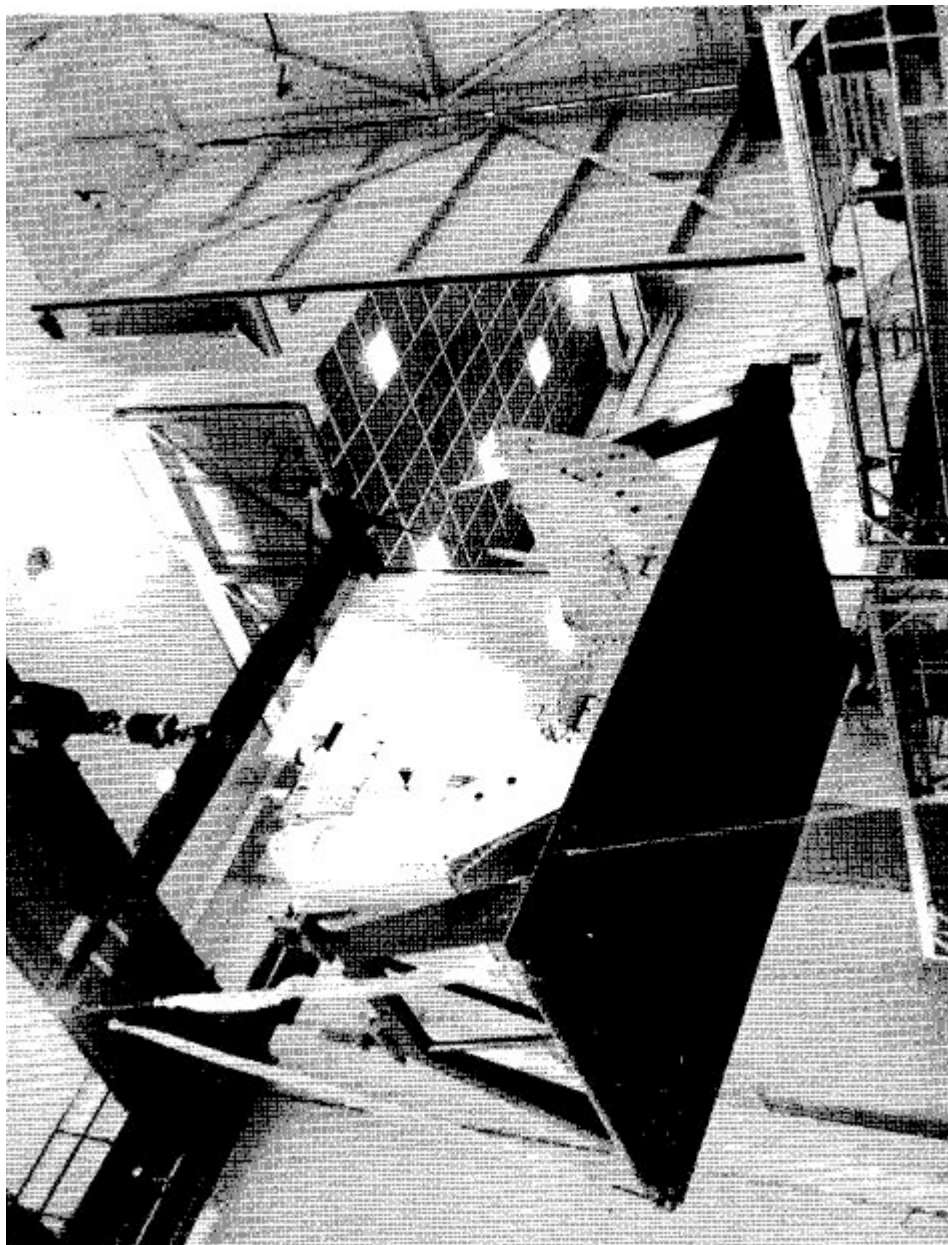

Figure 3-21. ESA Pallet Being Removed from the Class 10,000 Clean Work Area

RELEASED

K-STSM-14.1.14

3.4.7 FIRE DETECTION. Heat-actuated devices detect fire and activate the alarm system for the class 10,000 clean work area.

3.5 PORTABLE ACCESS AND HANDLING GSE

The GSE available in the bay area consists of both launch-site and ESA-supplied equipment for access to and handling of the payloads.

3.5.1 SPACELAB GSE. ESA constructed handling, access, and shipping equipment for the Spacelab racks, modules, end cones, igloo, and pallets. McDonnell Douglas-Huntington Beach furnished the tunnel dolley (yellow). The ESA GSE is painted a medium blue. Table 3-6 shows the ESA equipment. In addition, an overhead strongback is available for handling the Spacelab elements. See figure 3-22.

3.5.2 ACCESS EQUIPMENT. Portable access equipment consists of the following items:

- a. Hydraulic-powered scissor-lift work platform (figure 3-23)
- b. Four-step safety ladder (figure 3-24)
- c. Fourteen-step, 3-m (10-ft) safety ladder (figure 3-25)
- d. Access platforms for use at experiment integration and Mideast stands

3.6 VERTICAL ACCESS SIMULATOR (VAS)

In the east chamber (chamber L) located on the north side of the high bay is the vertical access simulator (VAS), used to train personnel in gaining access to the Spacelab module while it sits vertically in the orbiter at the launch pad. The VAS contains a mockup of the orbiter middeck, the Spacelab transfer tunnel, and the Spacelab module. The module vertical access kit (MVAK) is used in the VAS for training as well as in the flight vehicle as GSE for installing or removing flight hardware and specimens. The MVAK consists of pulleys; several harnesses; the joggle positioning ring, brace, and seat; and ladder and safety net - all of which allow a person to be lowered into the module from the middeck, to make the transfer through the 90-degree bend in the tunnel, and to gain access to the module. Entry to the VAS can be obtained from the high bay floor or through the top of altitude chamber "east".

RELEASED

Table 3-6. Spacelab GSE

SL ELEMENT	GSE
Pallet	Transport cage Attenuation frame Cover Pallet segment support integration trolley Mate and demate equipment Segment floor protection Desiccant canisters
Rack/Floor	Transport platform Shipping cover Support braces Installation and removal equipment
End Cone	Module/end cone mate equipment Cone-to-stand adapter Module and end cone transport platform Module and end cone shipping container Module and end cone handling rings
Module	Handling cage Horizontal access kit Vertical access kit Segment floor protection (see end cone for transport, shipping, and handling equipment)
Transfer Tunnel	Horizontal internal access Flex section retractor Protective end ring Extension hoist beam Handling sling set
Trunnions	Handling fixtures
Igloo	Handling and servicing dolly

RELEASED

K-STSM-14.1.14

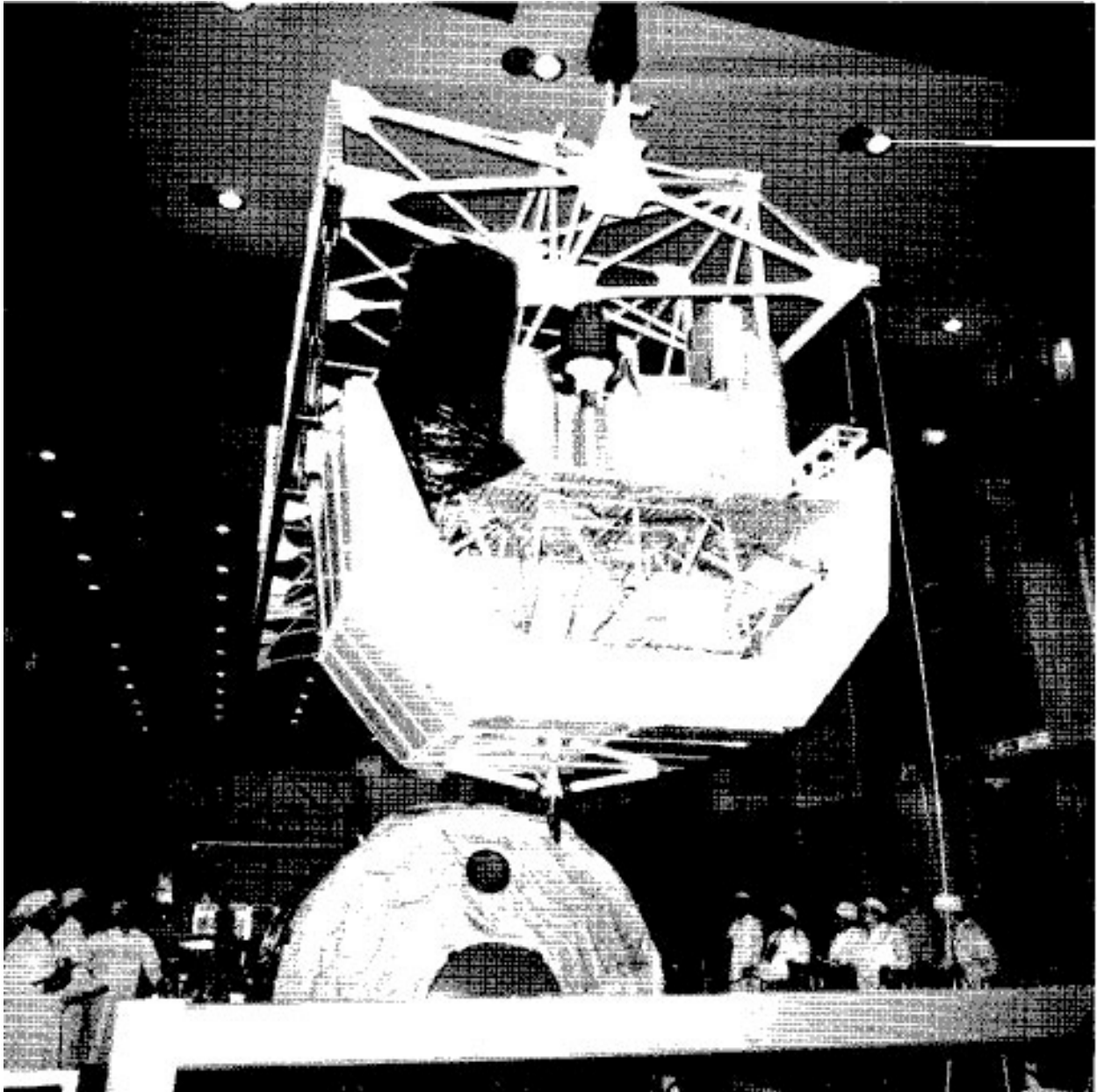

Figure 3-22. NASA Strongback Being Used to Handle a Pallet

RELEASED

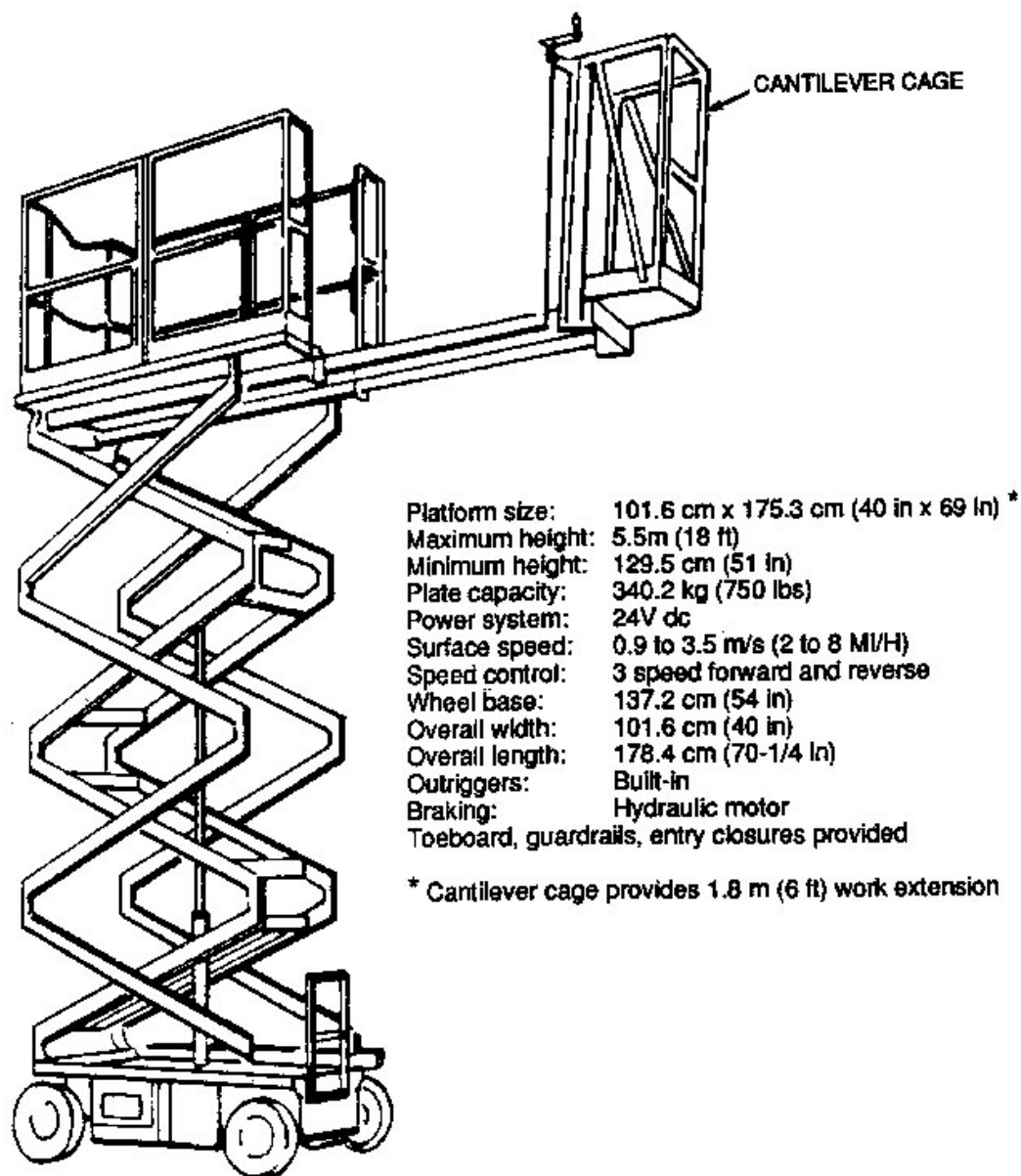

Figure 3-23. Hydraulic-Powered Scissor-Lift Work Platform

RELEASED

K-STSM-14.1.14

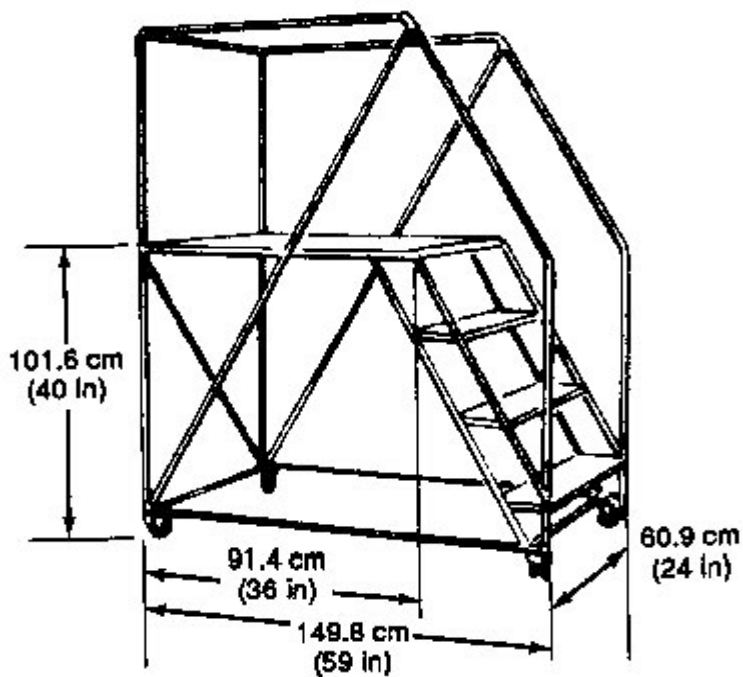

Figure 3-24. Four-Step Access Ladder

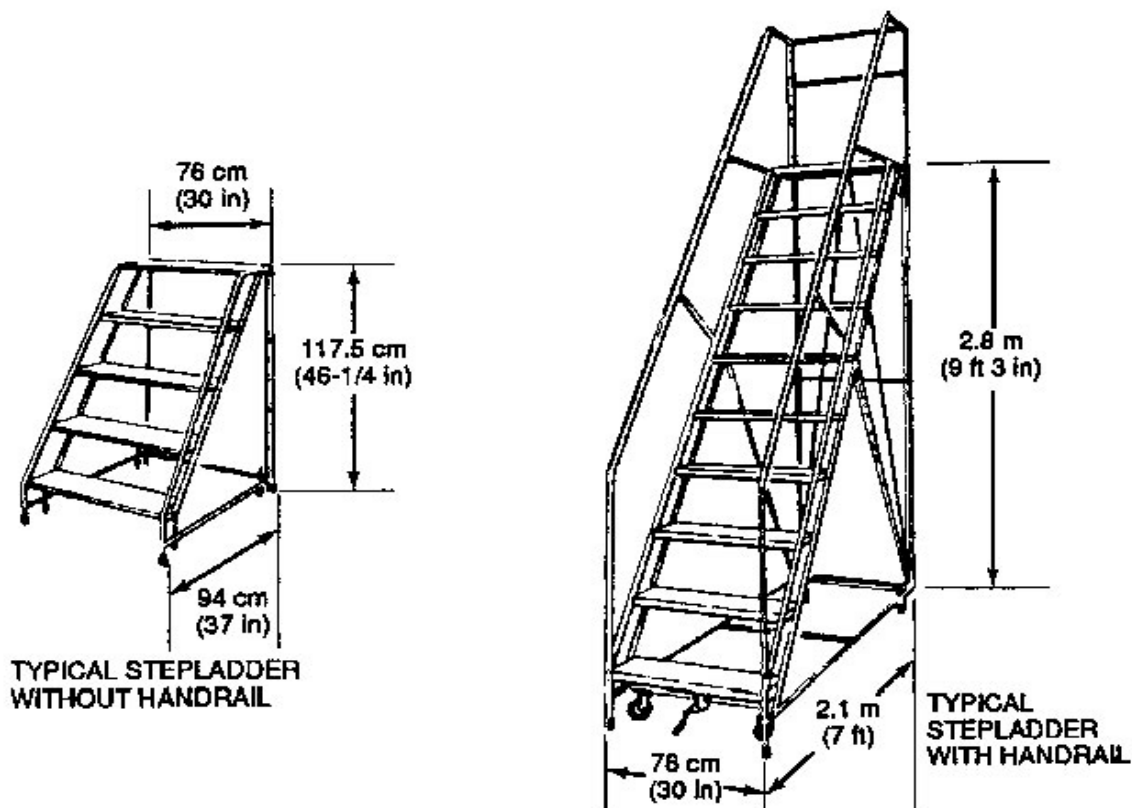

Figure 3-25. Typical Access Stepladders With and Without Handrails

SECTION IV

CONTROL AND MONITORING AREAS

4.1 GENERAL

Within the O&C Building are the control and monitoring areas for horizontal payload processing. This section presents the experiment integration control rooms, the Spacelab control rooms, the CITE control room, and the user rooms. All of the control rooms and the user rooms have 2.7 m (9 ft) ceilings and 60.9-cm (24-in) raised flooring. They are lighted with overhead fluorescent fixtures recessed in the ceiling that provide 1076 lm/m² (100 fc) or more. Because of the electronic equipment in these control and monitoring rooms, a water deluge fire suppression system is used. The system includes ionization detectors, piping for water dispersion, alarm bells, and revolving beam lights. The air handling units are automatically shut down when the system is activated. A summary matrix of the control and monitoring areas is found in table 4-1 at the end of this section.

4.2 EXPERIMENT INTEGRATION CONTROL ROOMS

The experiment integration control rooms are located in room 3259, which is 10.5 m (34 ft) wide by 12.2 m (40 ft 2 in) long, and room 3255. Equipment layout of room 3259 is shown in figure 4-1. A similar arrangement exists in room 3255. The rooms are used for control and monitoring of experiment integration testing and for processing and monitoring data transmitted via the Spacelab experiment computer input/output (ECIO) channel during all subsequent levels of integration.

The PCU control equipment and High Rate Multiplexer Input/Output Test System (HITSs) 1 and 2 are located in room 3259. A second PCU is located in room 3255 and HITS 3 and 4 are in user room B (4255). Room 3255 also contains a conference and library area.

4.2.1 PCU. The purpose of the PCU is to test Spacelab experiments using a simulation of the Spacelab Command and Data Management System (CDMS), Orbiter avionics interfaces, and to allow monitoring and control of electrical and mechanical GSE within the experiment integration area. The PCU also provides post-test data reduction, with the post-test reduction done on a non-interference basis with real-time support. The two PCUs provide the capability of processing the experiments for two Spacelabs concurrently. Either PCU can support either a module or an igloo mission in either the north or south experiment integration stand independently of the other PCU and test stand.

4.2.2 HITS/Peripheral Processor (PP). During payload and orbiter integration, the HITS receives Spacelab ECIO data, or experiment dedicated channel data, from the Spacelab high rate demultiplexer (HRDM) and, through the PP system, presents to the Principal Investigator (PI) the data needed to assure proper operation of this experiment. The PP system supports simulated POCC uplink commanding through an interference with the PCU.

RELEASED

K-STSM-14.1.14

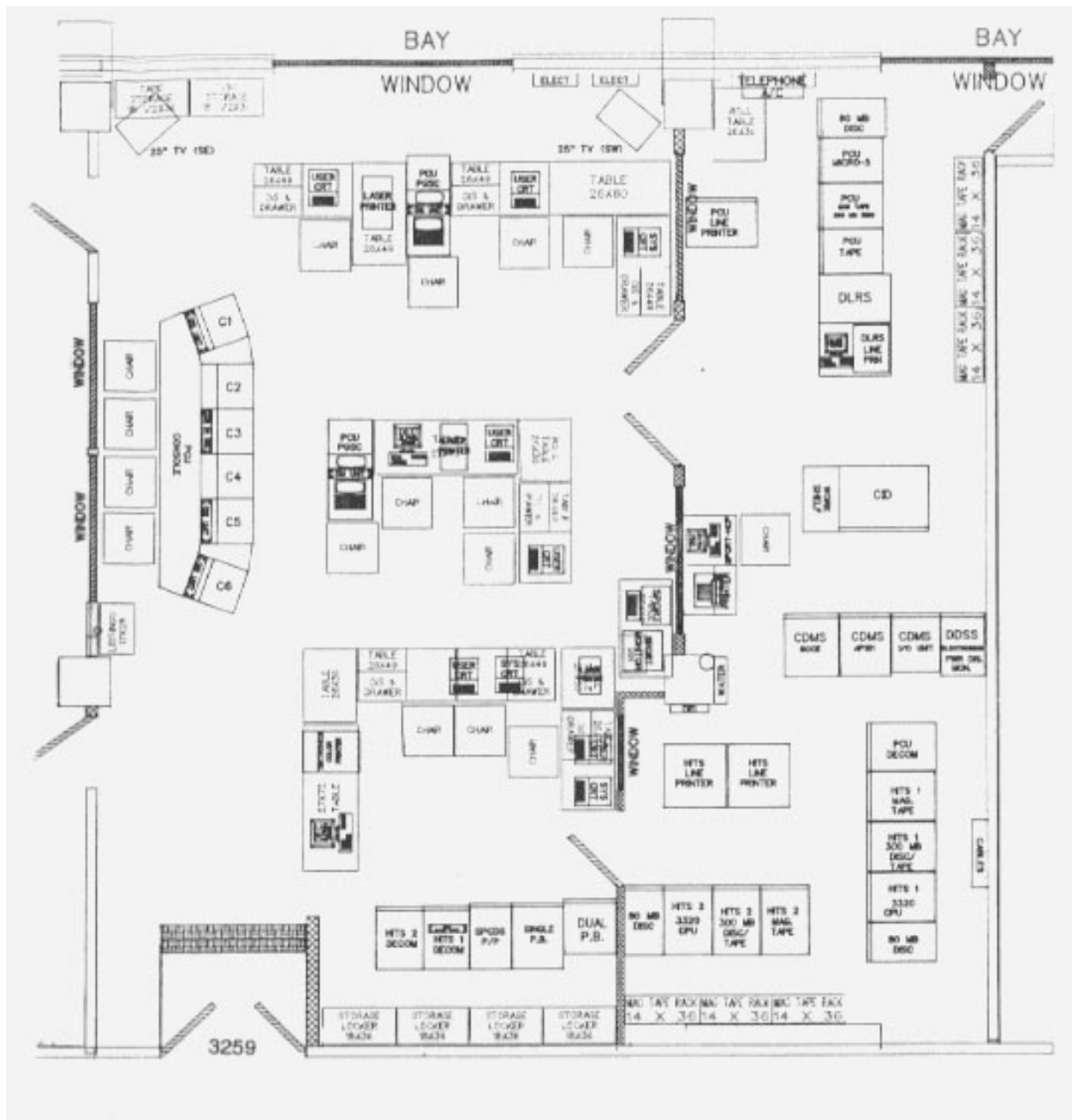

Figure 4-1. Experiment Integration Control Room 3259

The HITS is comprised of a processor and peripherals, CRT displays, and a decommutator input interface. The decommutator input interface retrieves Spacelab ECIO data, or experiment dedicated channel data, for access by HITS applications and the PP system. Only measurements supported by the POCC data base can be supported by HITS. The decommutator input interface also provides 10 analog measurement outputs and 32 discrete measurement outputs for transmission to the user rooms. An additional capability exists to transmit 5 serial digital signals from the HITS processors to the user rooms. Figure 4-2 is a block diagram showing the interconnection of the PCU and HITS and the user rooms.

4.3 SPACELAB CONTROL ROOMS

The Spacelab control rooms 1 and 2 are rooms 3247 and 3251, respectively. The equipment layout in room 1 is shown in figure 4-3. Room 2 contains a similar layout and the same equipment. Each room is 12.2 m (40 ft 2 in) long by 11.3 m (37 ft) wide. Each Spacelab control room houses the ATE, which is computer-controlled equipment used for electrical power-up testing of the Spacelab in the bay area. Payload integration test and checkout activities are controlled from these rooms. Overall test activities and integrated tests are controlled by the test engineers who operate and monitor Spacelab subsystems from the ATE consoles.

4.4 CITE CONTROL ROOM

The CITE control room is located in room 3233, an approximate 9.1 m (30 ft) wide by 12.2 m (40 ft) long area containing hardware like that developed for the KSC Launch Processing System (LPS). This LPS-type hardware is integrated with the CITE electrical and electronic set test stand hardware to provide display, monitoring, control, data conversion, and data processing for the payload interface verification. The test stand hardware (see section 3.2.3.3) serves as the simulated orbiter interfaces to the payload. Payload interface verification for both vertically and horizontally processed payloads is conducted from room 3233.

The CITE control room equipment consists of test consoles containing keyboards, color CRT displays, and mini-computers with extensive disc storage for flexible parallel testing and monitoring by the test engineers. A diagram of the equipment layout in the CITE control room is shown in figure 4-4. A CITE functional block diagram is shown in figure 4-5. Rooms 3227 and 3245 contain support equipment for room 3233 and room 3237, the Engineering Support Area.

The Record and Playback Assembly in room 3245 can provide, upon completion of testing, a magnetic tape recording of downlink data collected during the testing.

RELEASED

K-STSM-14.1.14

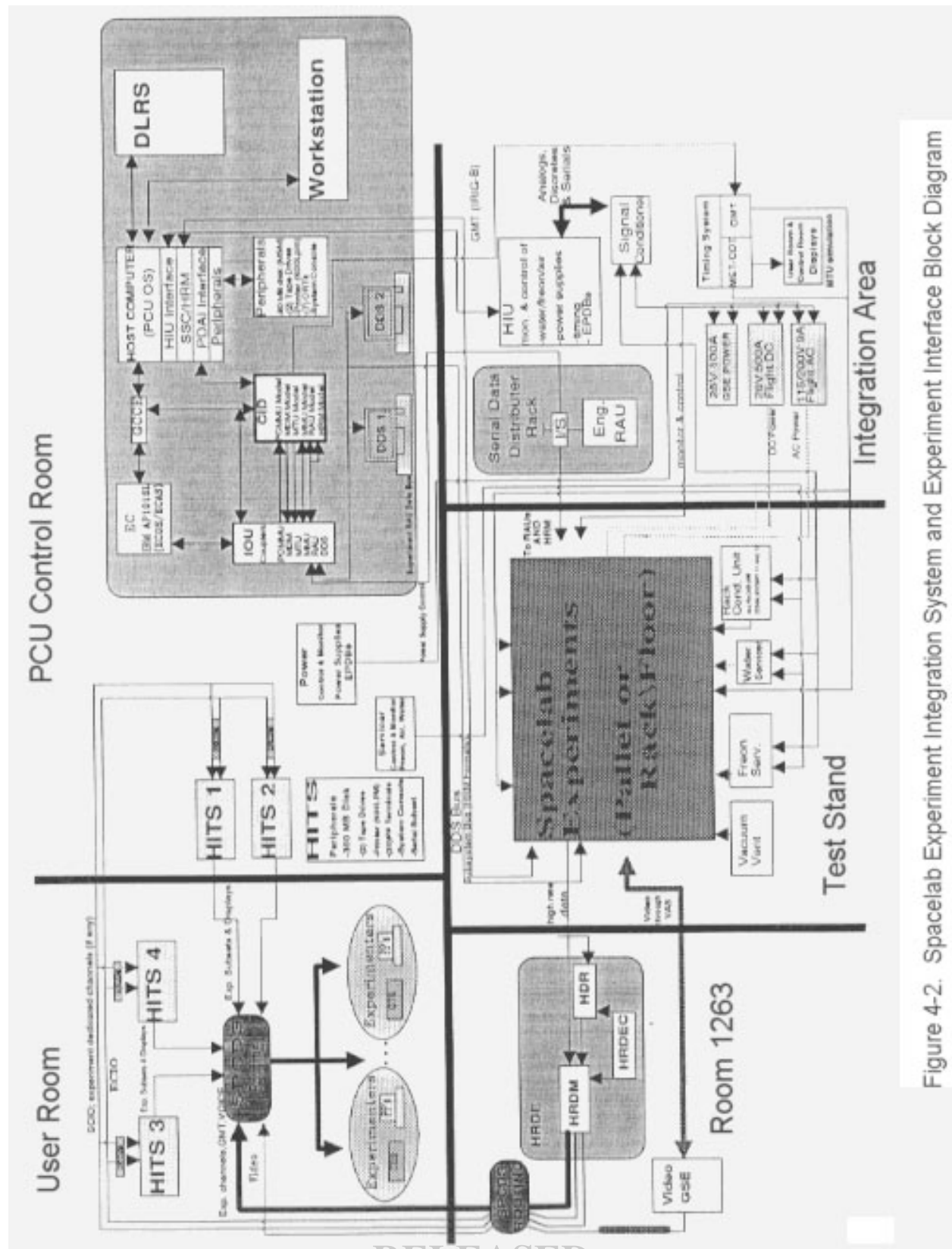

Figure 4-2. Spacelab Experiment Integration System and Experiment Interface Block Diagram

RELEASED

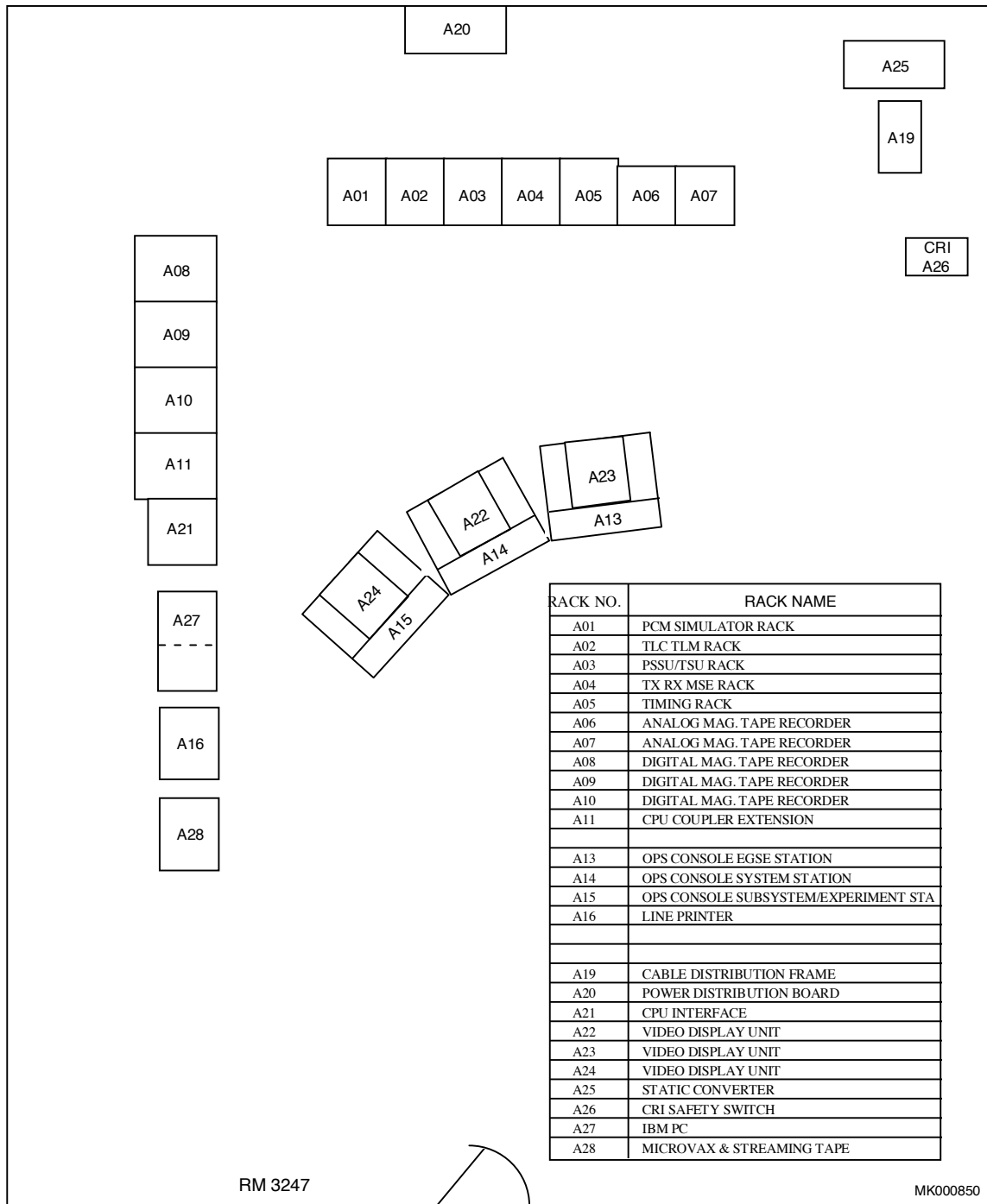

Figure 4-3. Spacelab Control Room 1, Room 3247

RELEASED

K-STSM-14.1.14

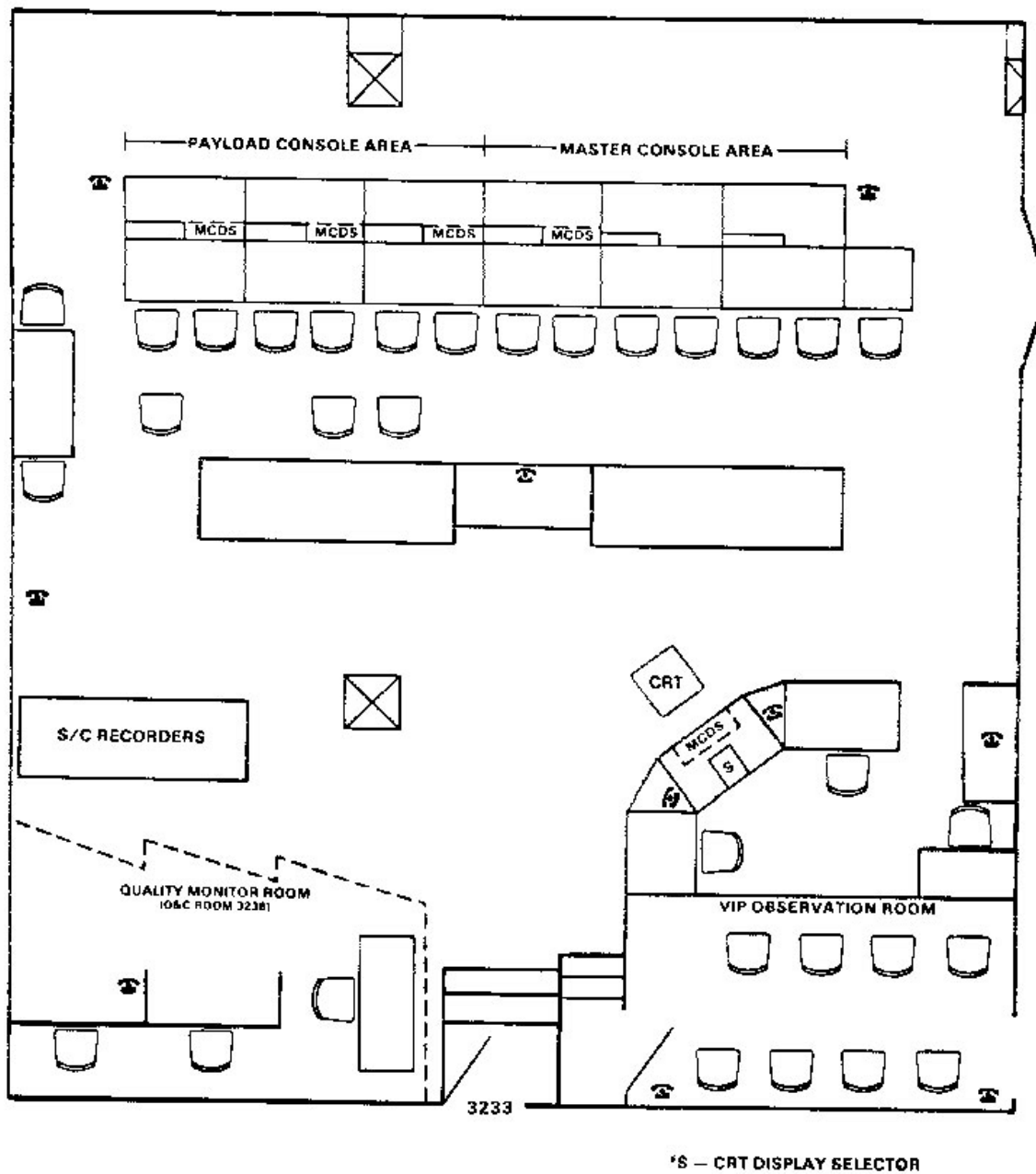

Figure 4-4. CITE Control Room

RELEASED

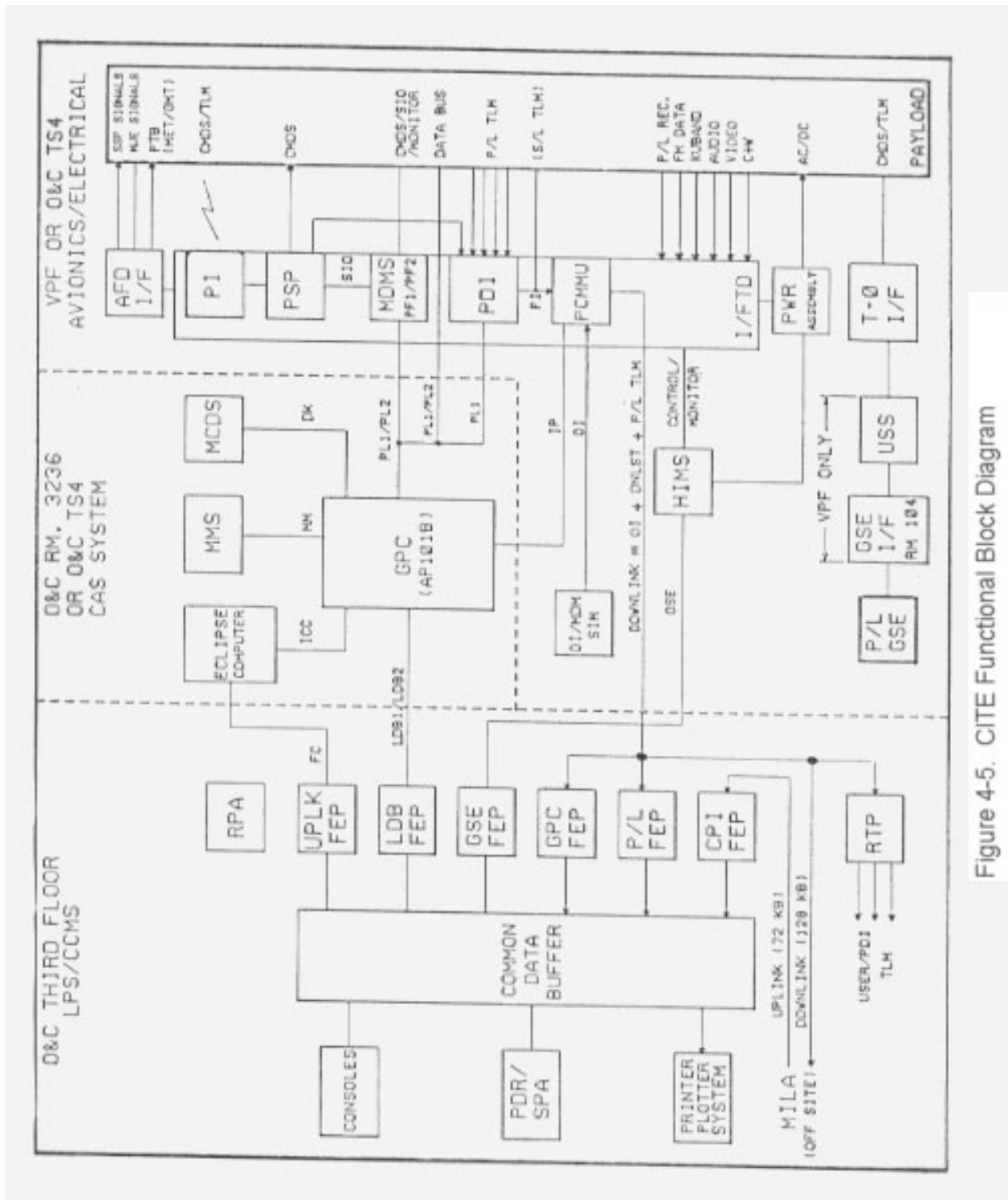

Figure 4-5. CITE Functional Block Diagram

RELEASED

K-STSM-14.1.14

4.5 ENGINEERING SUPPORT AREA (ESA)

The ESA is located in room 3237. Its purpose is to allow the customer to monitor the payload and upper stage parameters independently of control room monitors during integrated testing of the payload in the bay area or at the VPF. The customer can then participate in problem troubleshooting as necessary. The ESA also provides technical support to the systems engineers in the CITE control room during CITE testing.

The ESA contains television monitors of a multi-function CRT display system referred to as the AFD displays, CRT monitors of control room LPS displays and customer-requested ESA displays, OIS, telephones, and the LPS master console. Figure 4-6 depicts the layout of the ESA in room 3237.

4.6 HIGH RATE MULTIPLEXER TEST STATION AND CCTV ROOM (Room 1263)

The HRM Test Station and CCTV room is located on the first floor of the O&C Building. This room contains equipment that handles the following tasks:

- a. Distribution of Spacelab and experiment integration HRDM data and clock channels to the user rooms and to the HITS in rooms 3259 and 4255A
- b. Reception and distribution of the Spacelab HRM output signals after Spacelab is installed in the orbiter
- c. Distribution of CCTV to the payload video switch, the user rooms, and routing of ECE to the ECE between the user rooms and the test stands
- d. Spacelab onboard CCTV system checkout and troubleshooting
- e. Data are processed and transferred to various locations during CITE and OPF testing of Spacelab.

4.7 USER ROOMS

The user rooms are located on the fourth floor of the O&C Building in room 4239 (user room C), room 4255 (user room B), and room 4265 (user room A). The user rooms each have dimensions of approximately 12.2 m by 26.5 m (40 ft by 87 ft). The main doors for entry are 1.4 m (4 ft 6 in) wide by 2.4 m (7 ft 9 in) high. Each room may be divided into several areas with a 4.8 m by 5.2 m (16 ft by 17 ft) test operations room occupying a central area that serves as a focal point for all test operations. The remaining user areas may be separated by sound-absorbing movable partitions that may be arranged to accommodate the space allocations of the experimenters assigned to the mission. Allowable load on raised flooring is 1220.5 kg/m² (250 lb/ft²). Figure 4-7 shows the layout of the user rooms. Figure 4-8 shows the plan of a typical user room.

RELEASED

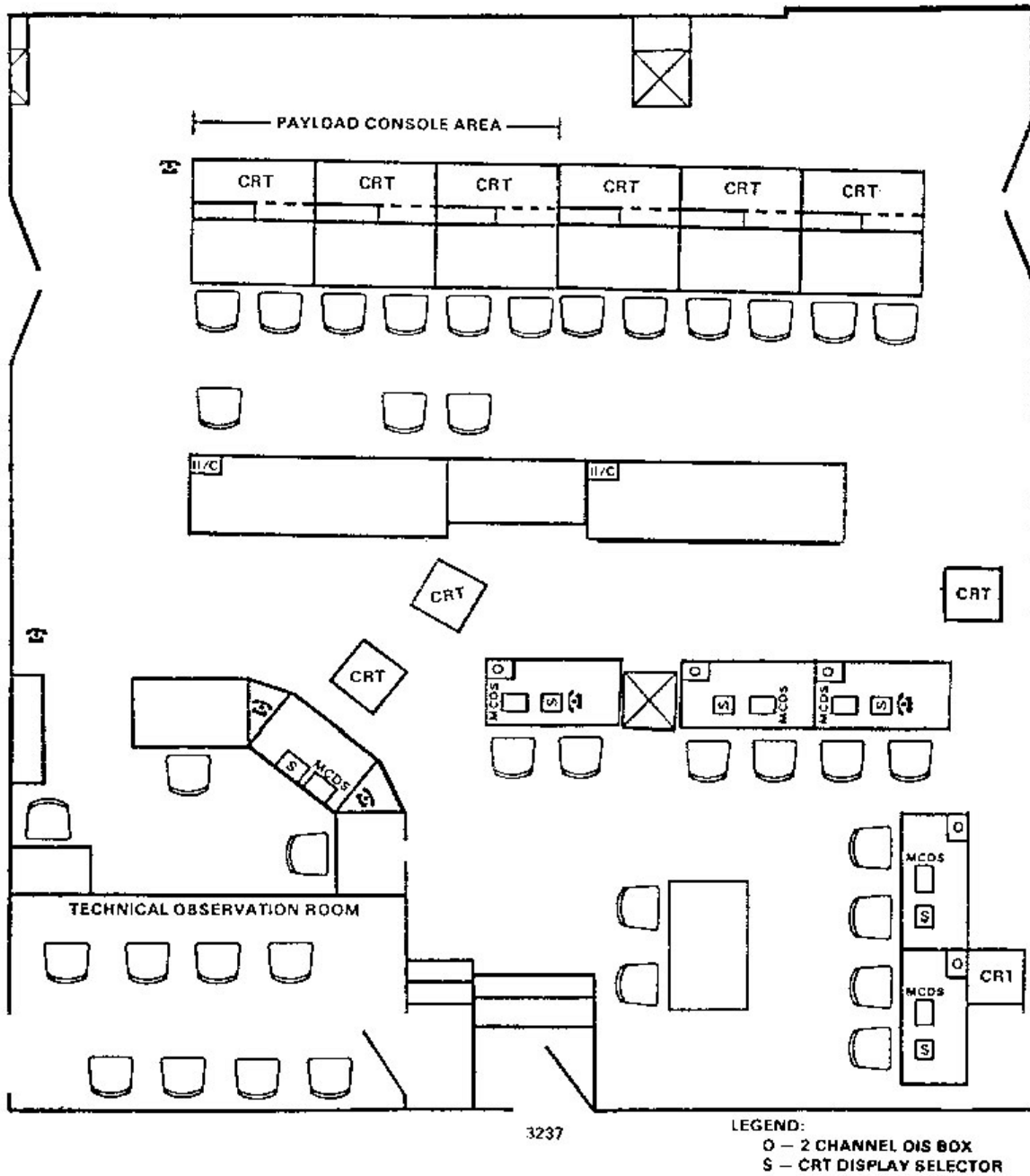

Figure 4-6. Engineering Support Area (ESA), Room 3237

RELEASED

K-STSM-14.1.14

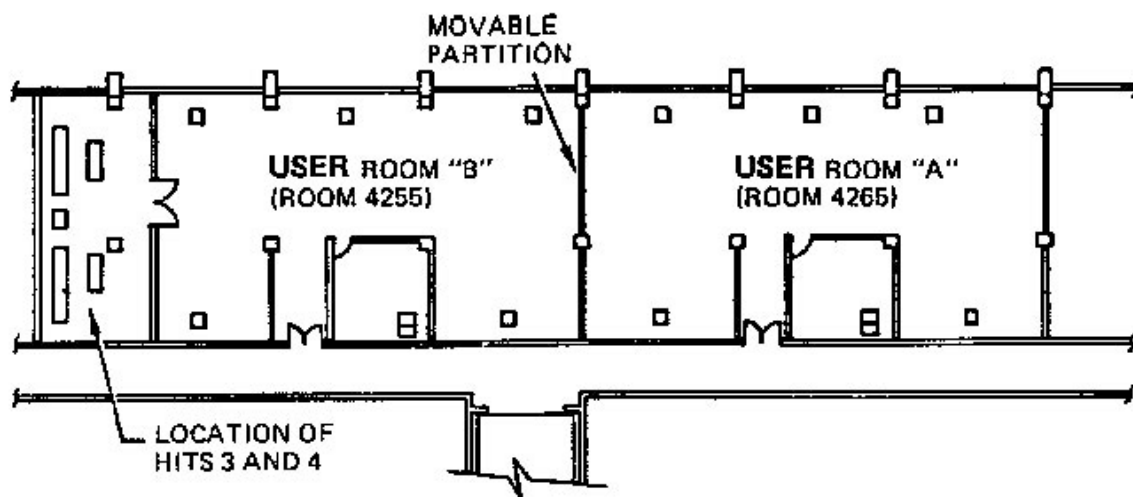

Figure 4-7. User Rooms

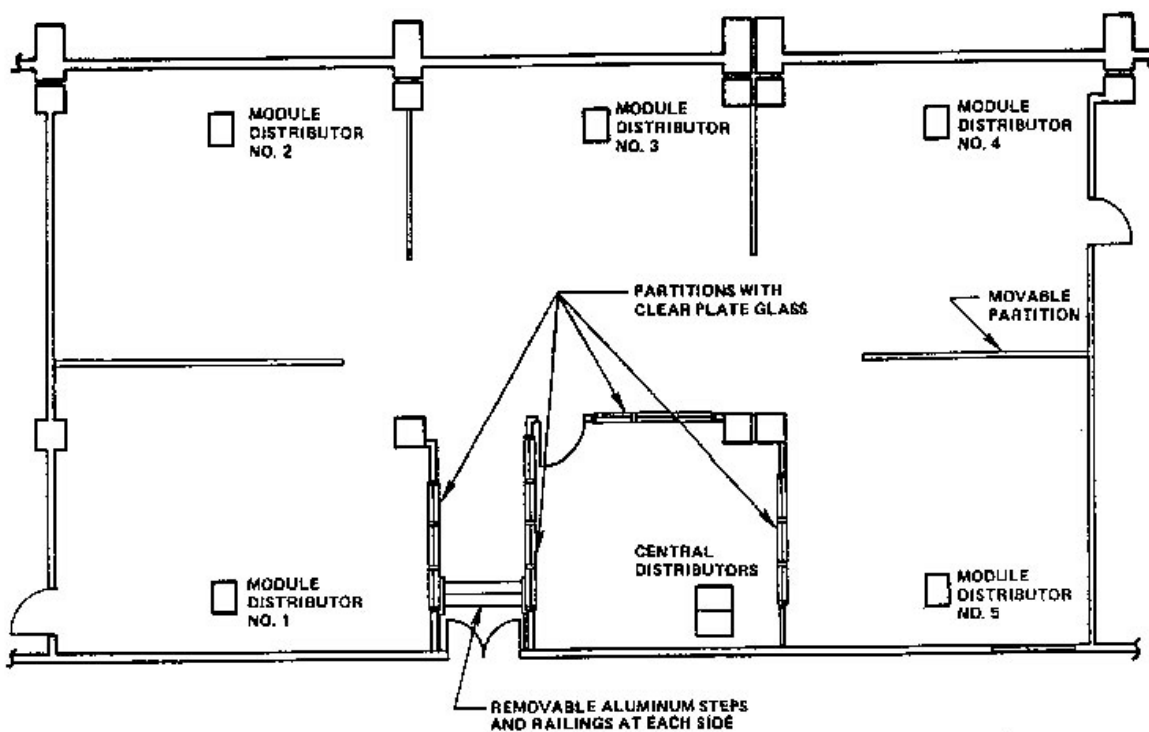

Figure 4-8. Typical User Room Layout

RELEASED

4.7.1 USER ROOM SUPPORT PROVISIONS. The support provisions in the user rooms are described in the subsequent paragraphs. This information is included to familiarize the experimenters and payload personnel with the facilities available during their occupancy in the assigned areas.

4.7.1.1 Lighting. As stated in paragraph 4.1, fluorescent modular fixtures mounted flush in the ceiling provide lighting in the user rooms. One out of every four of these panels contains emergency lights. Each user room is equipped with between 71 and 84 fixtures.

4.7.1.2 Fire Suppression. The user rooms are protected by a pre-action sprinkler system activated by cross-zoned photoelectric smoke detectors.

4.7.1.3 Environmental Control. The air-conditioning is set to maintain the temperature at 21.7 ± 3.3 degrees C (71 ± 6 degrees F). The air-conditioning normally operates between 0700 and 1700 hours. If operations in the user room require air-conditioning at times other than those hours, the NASA test conductor must be notified.

4.7.1.4 Electrical Power Distribution. Single-phase ac, 60-Hz, 120-V \pm 3% power is distributed in each room on wall-mounted 15-A duplex receptacles. Under the raised floor runs a raceway with 1- \emptyset , 30-A receptacles and some 30-A receptacles for 208-V, 3- \emptyset power. 480-V, 3- \emptyset , 60-A power is also available in each user room. 79K16211 shows the detailed receptacle types and locations.

4.7.1.5 Grounding. A dual grounding net runs under the raised floor for grounding equipment enclosures for shock protection (E Ground) and for signal returns (I Ground), the latter being insulated from the structure. Both nets consist of 10.2-cm (4-in) copper tubes with a connection tab welded approximately every 0.6 m (2 ft). Every tab has a 0.95-cm (3/8-in) clearance hole.

4.7.1.6 OIS. This OIS ties the integration area, the HRM Test Station (PPCU) and CCTV Room (1263), the PCU control rooms (3255 and 3259), and the user rooms. Each unit can access two selectable channels. The operation of the OIS in the O&C Building is presented in section 3.1.13.1. The OIS units are mounted in racks and in the module distributors in each user room.

4.7.1.7 Experiment TV Monitoring. OTV monitoring of experiment activities in the area is available in the user rooms.

4.7.1.8 Master Timing. Master timing signals originating from the different sources are distributed in the user room in two forms. Three ceiling-mounted digital displays provide continuous readout of selectable sources (PCU, PPCU, and ATE). Additionally, every module distributor provides electric timing signals under the following IRIG formats:

- a. IRIG A (1000 pps markers)
- b. IRIG B (100 pps markers)
- c. IRIG H (pps marker)

RELEASED

K-STSM-14.1.14

Every module distributor has five MS3450I-14S-7S connectors for the signals listed in a, b, and c and one spare for non-standard requirements. Jumpers will be provided by KSC, terminated with BNC Trompeter PL20-2 connectors.

4.7.2 SIGNAL DISTRIBUTION. The interface between the experiments and the user rooms is provided by the SPCDS, and the HITS facility as shown in figure 4-10. The collection point for the various data streams is room 1263, where the SPCDS distributor receives all signals and provides the line drivers and patching capability needed to transmit these data to any user room.

Data are received in the central user distributor, located in the control module of every user room. The function of this distributor is to patch different subsets of the incoming signals to any one of the five module distributors provided in each user room. The central distributor also receives the master timing signals for distribution as noted previously. For most signals, there are no driving electronics in the central user distributor.

Every module in the user rooms contains one module distributor that is the data output stage to the user. The module distributor generally receives only a subset of the signals present in the central distributor. In most cases, this subset is driven in the module distributor, with a fan-out factor of 2 or 4.

Users interface with the module distributor by user-provided jumper cables of the appropriate type for each data stream. These jumpers will be 4.5 to 6.2 m (15 to 20 ft), and will be terminated with the connectors indicated in the following paragraphs. The details of the available data stream are also described in the subsequent paragraphs.

4.7.2.1 HRDM-Delivered Experiment Data. The experiment data processed and included in the output of the HRDM consist of the following:

- a. Traffic of low-rate data controlled by the remote acquisition units (RAUs) and the ECIO channel
- b. Sixteen experiment-dedicated channels and the direct access channel (DACH) for the high-rate data
- c. Burst time--i.e., the GMT sample retrieved from the status word of HRM formats--and the HRM format sync pulse
- d. Three experiment voice channels

RELEASED

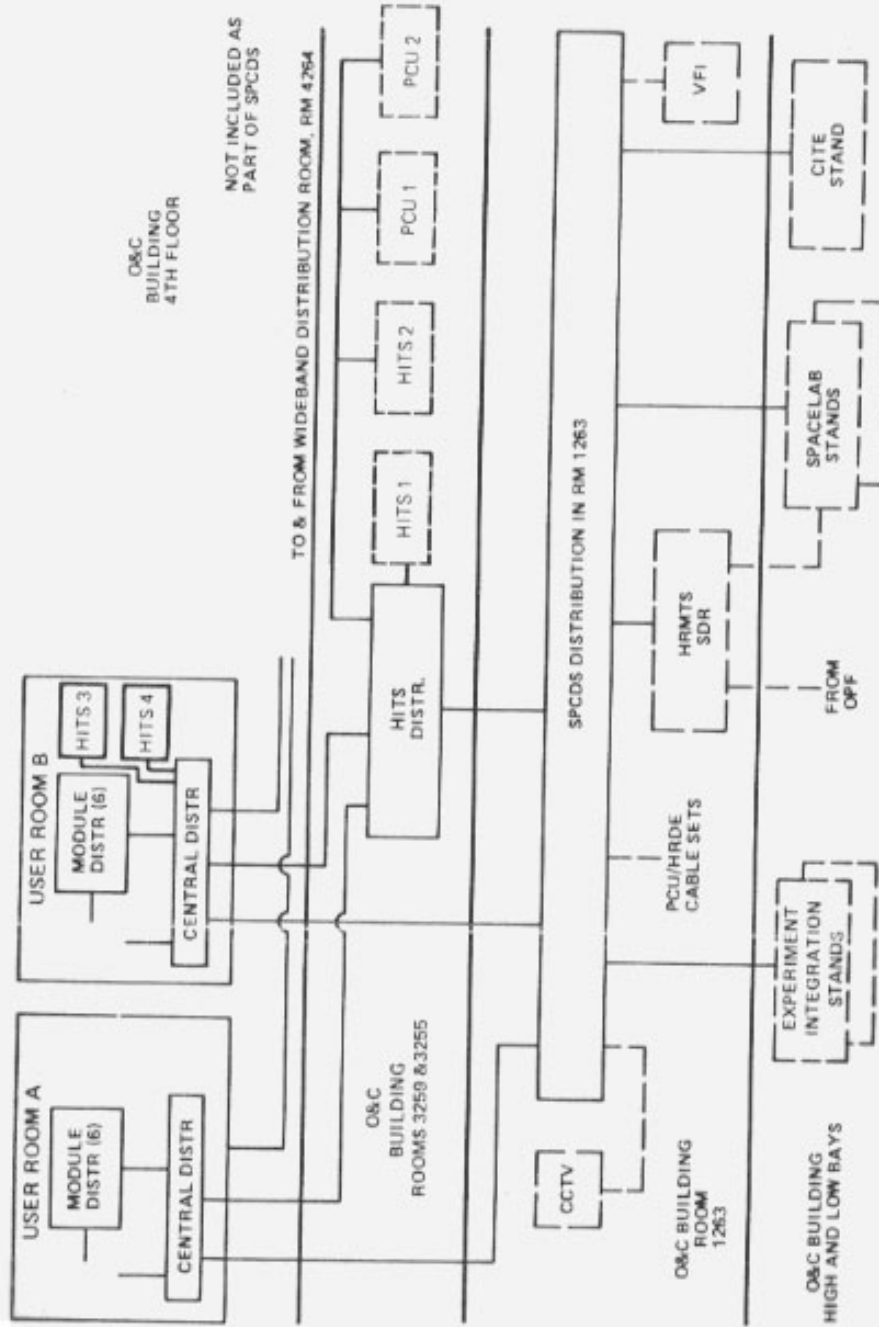

Figure 4-9. SPCDS Overview

RELEASED

K-STSM-14.1.14

All these are defined in section 4.4 of the *Spacelab Payload Accommodations Handbook*, SLP/2104. They are handled by the SPCDS as follows:

- a. **ECIO Channel.** The ECIO channel is a non-experiment-specific composite stream of pulse-code-modulated (PCM) signals that may have been, on output from the experiments, digital, analog, or discrete. This composite is transmitted to any user room over twisted shielded pair (TSP) lines, with line receivers and drivers in the SPCDS, central user, and module distributors.

The ECIO stream can be transmitted simultaneously to any three module distributors in a user room, and to four outlets at every one of these. The user must provide his own electronics to decommutate this stream. The output jumpers should be constructed of Trompeter TWC78-2 cable (78-ohm TSP) and terminated with a Trompeter PL75-9 or equivalent connector.

The ECIO stream is also processed in the HITS facility, which consists of two functionally identical branches: the HITS branch for experiment integration data and the HITS branch for the other levels of integration. Each of these branches is made up of a decommutation station and an 8/32 minicomputer. The decom station processes the ECIO channel and delivers experiment specific analog and discrete signals that can be patched to any user room. For the discrettes, the interface jumpers out of the module distributor are terminated with an MS3106E28-21S connector. The jumper connector for the analogs is an AMP 26-pin, series M with assembly A and type III(+) sockets.

The HITS computer also processes the ECIO stream and outputs digital data in serial blocked form, of which there are two channels from a central user distributor to every module distributor, with the constraint that only eight such channels are available in any one user room at a time. The corresponding interface jumpers are again terminated with a PL75-9 connector.

Finally, the HITS computer has eight parallel interfaces for driving as many remote CRT terminals, on which the decommutated ECIO stream can be automatically displayed. Four connectors exist for this purpose on every module distributor, and a limited pool of terminals is available for the user rooms.

- b. **Experiment Channels.** The 16 experiment channels received in the SPCDS distributor are transmitted to any one central user distributor. From there, any four of these channels can be patched to any one module distributor, where they pass through a receiver-driver that provides two outputs per channel. The interface jumpers are constructed of TWC78-2 cable and terminated with PL75-9 connectors.
- c. **Direct Access Channel.** The direct access channel received from the Spacelab is transmitted to any one central user distributor; from there it can be patched to any module distributor. The output amplifier at

this station yields two outputs, delivered through jumpers made of TWC78-2 cable and terminated with PL75-9 connectors.

- d. Burst Time and Format Sync. Burst time (the GMT sample retrieved from the status word of the HRM format frames) is transmitted in PCM form to any central user distributor, where it is amplified with a fan-out factor of 3, and again at the module distributors. It is, therefore, available at four outlets of any three module distributors through TWC78-2 cable jumpers terminated with PL75-9 connectors. The format sync pulse can be distributed to any module distributor.
- e. Voice. All three voice channels delivered by the HRDM are transmitted to any central user distributor and patched from there to any module distributor, where speaker output from any one selectable channel is available.

4.7.2.2 Experiment TV and Analog Channel. All three experiment TV channels are received in the SPCDS distributor and patched over to the desired central user distributor on 75-ohm coaxial line. From there, they can be patched in any combination to any module distributor. A total of three TV monitors is provided for each user room. These, or the user's own monitors, can be plugged in at the end of a KSC-provided jumper terminated with a Trompeter BNC UPL20-2 or equivalent connector.

The 4.5-MHz analog channel is similarly distributed and also accessible to the user at any one module distributor through a KSC-provided jumper terminated with a UPL20-2 connector.

4.7.2.3 Instrument GSE (IGSE) Lines. The user-provided IGSE, also called ECE on the integration floor and in the user room, can be interconnected by means of 54 dedicated lines. The ad hoc connector brackets (ref. des. 4841 and 4843) are provided at the east end of the south and north experiment integration stands, respectively, and another two (ref. des. 4842 and 4844) at the west end of these stands. A set of six 124-ohm TSP and six 78-ohm TSP lines is connected from each bracket to the SPCDS distributor. Additionally, three 75-ohm coaxial cables are connected from each west-end bracket to the SPCDS distributor. From there, these lines are patched, without driven electronics, to any central user distributor, and continued there with 15.2-m (50-ft) jumpers of the corresponding type of cable, terminated with a PL75-9 connector for the TSP lines, and with a UPL20-2 connector for the coaxials. These lines are not routed to the module distributors, but will be laid under the raised floor as requested for each mission. Connectors on the module distributor and digital analog central distributor racks are MS3114P14-19S.

4.8 PAYLOAD CUSTOMER MANAGEMENT CENTER (CMC)

The Payload CMC is located in room 4269. It provides space for meetings and CCTV viewing of bay area operations during payload processing and CITE testing. Use of this room is controlled by CS-PTS. Figure 4-10 shows the layout of the CMC.

RELEASED

K-STSM-14.1.14

Table 4-1. Control and Monitoring Area Summary

Parameter Location	Area m ² (ft ²)	Ceiling Height m (ft-in)	Entryway(s) m (ft-in)	ECS (0700 h to 1700 h)	Electrical Power	Communications	Data Handling	Remarks
Exemp Integ Control Room (3259)	126.3 (1360)	2.7 (9) 60.9-cm (24 in.) Raised Floor	2.4 H x 1.4 W (7-11 X 4-7)	18.3° to 26.7° C (65 to 80° F) STD, O&C Bldg.	120V, 60 Hz, 1Ø, 15 & 30A 120/208V, 60 Hz, 3Ø, 30A	OIS CCTV Timing (IRIG A, B, H)	HITS ECEP PCU	Halon Fire Suppression System
Specialab Control Rooms (3247 and 3251)	137.5 (1480) Each	2.7 (9) 60.9-cm (24 in.) Raised Floor in Both	Room 3247: 2.1 H x 0.9 W Clear (6-11 x 2-10) Room 3251: 2.4 H x 0.9 W Clear (7-11 x 2-10)	18.3° to 26.7° C (65 to 80° F) STD, O&C Bldg.	120V, 60 Hz, 1Ø, 30A 120/208V, 60 Hz, 3Ø, 30A	OIS CCTV Timing (IRIG A, B, H)	ATE	Halon Fire Suppression System
CITE Control Room (3233)	111.5 (1200)	2.7 (9) 60.9-cm (24 in.) Raised Floor	2.4 H x 0.9 W Clear (7-11 x 2-10)	18.3° to 26.7° C (65 to 80° F) STD, O&C Bldg.	120V, 60 Hz, 1Ø, 30A 120/208V, 60 Hz, 3Ø, 30A	OIS CCTV Timing (IRIG A, B, H)	LPS	Halon Fire Suppression System
User Rooms (4249 and 4255) (4266)	323.3 (3480) Each	2.7 (9) 60.9-cm (24 in.) Raised Floor in All	2.4 H x 1.4 W (7-11 x 4-8) All Rooms	18.3° to 26.7° C (65 to 80° F) STD, O&C Bldg.	120V, 60 Hz, 1Ø, 15A 208 V, 60 Hz, 3Ø, 30A	OIS Exprmt TV Analog Channel Timing (IRIG A, B, H)	HITS, ECEP, HRDM Data	Halon Fire Suppression System, Primary Payload Monitoring Areas
ESA Room (3237)	() 1100	2.7 (9) 60.9-cm (24 in.) Raised Floor in All	2.4 H x 1.4 W (7-11 x 4-8) All Rooms	18.3° to 26.7° C (65 to 80° F) STD, O&C Bldg.	120V, 60 Hz, 1Ø, 15A 208 V, 60 Hz, 3Ø, 30A	OIS Exprmt TV Analog Channel Timing (IRIG A, B, H)	Monitor Only: LPS, HITS, ECEP, HRDM Data	Halon Fire Suppression System, Primary Payload Monitoring Area

MK000683

RELEASED

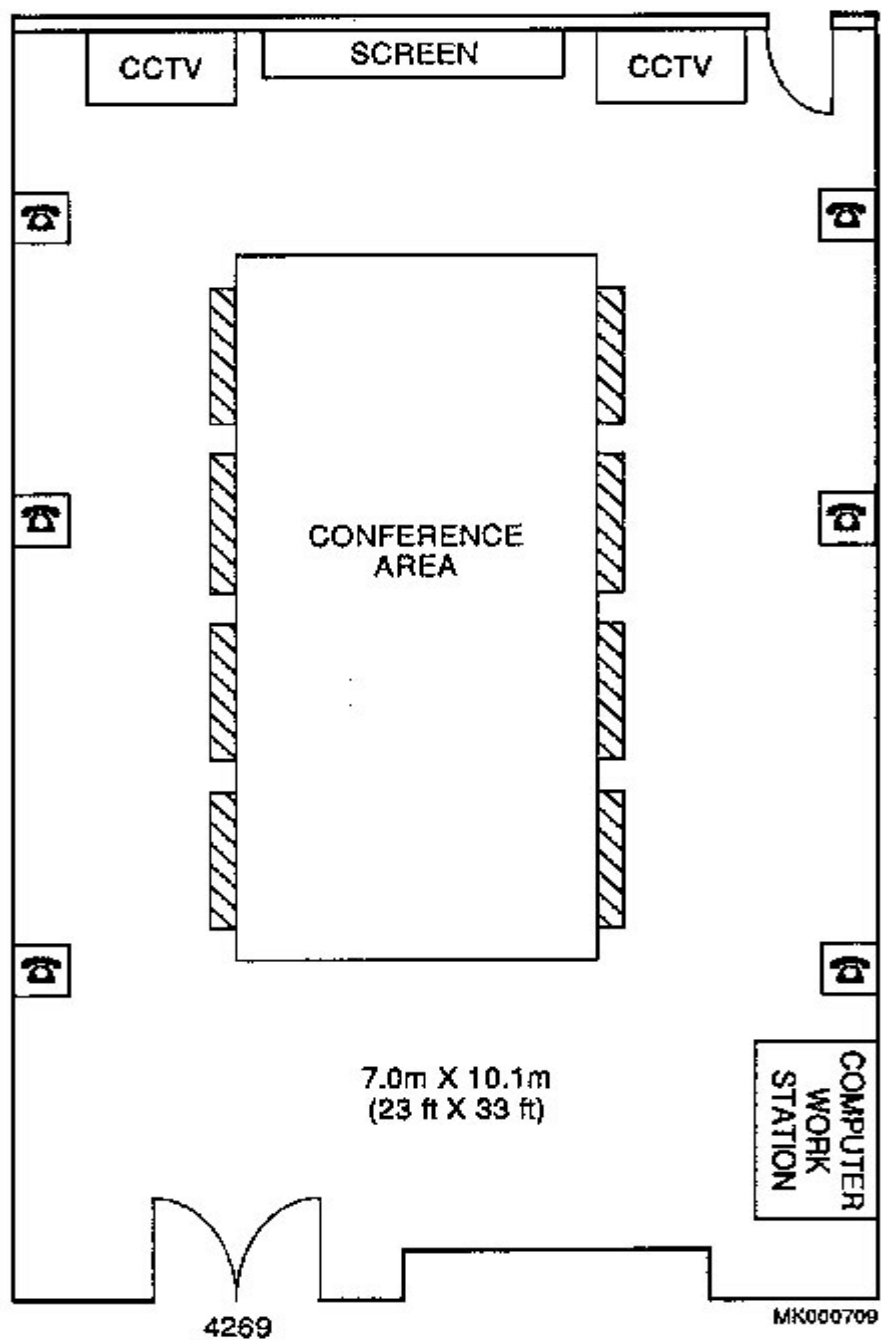

Legend:

 Indicates OIS consoles (16 hook-ups total)

RELEASED
Figure 4-11. Payload Customer Management Center (CMC), Room 4269

K-STSM-14.1.14

THIS PAGE INTENTIONALLY LEFT BLANK

RELEASED

SECTION V

LABORATORIES AND SHOPS

5.1 GENERAL

The O&C Building contains laboratory and shop areas to support the Space Shuttle and payload ground processing activities, as well as the routine operations and maintenance of the KSC facilities. Use of these laboratories and shops and their services must be requested and scheduled as an optional service. Some of the areas are dedicated for payload support; other areas can support payload activities on an as-available basis only. Technical point of contact for this area is the experiment project engineer. See each subsection for clarification.

This section presents the laboratories and shops grouped by junction and location, as appropriate. Figures 5-1 through 5-4 show the laboratory and shop areas of the O&C Building.

5.2 EXPERIMENT LABORATORIES

5.2.1 GENERAL-PURPOSE LABORATORIES. The experiment laboratories are a group of rooms on the first and second floors of the O&C Building that are assigned for particular experiment off-line operations. They are used for both preflight and postlanding operations.

The air handling equipment in these laboratories, as for most of the O&C Building, is set to maintain the temperature at 21.7 ± 3.3 degrees C (71 ± 6 degrees F). Environmental control is maintained between 0700 hours and 1700 hours. Special arrangements may be made if environmental control is required during other hours.

The cleanliness level of these laboratory areas is maintained at least at a Level 5 clean work area. See K-STSM-14.2.1.

Each off-line laboratory has single phase, 60-Hz, 120-V ac $\pm 3\%$ power receptacles. There are wall-mounted NEMA duplex receptacles and NEMA L5-30R receptacles. Some 208-V ac, 1- \emptyset and 3- \emptyset power is available for NEMA L21-30R receptacles. See 79K16211 for detailed receptacle locations and identification.

All areas are equipped with telephones.

Table 5-1 lists the room numbers, square footage, ceiling heights, and facility equipment and services provided. The locations of the experiment labs are shown in figures 5-1 through 5-4. Figures 5-5 through 5-9 show the layouts of several of the experiment labs.

RELEASED

K-STSM-14.1.14

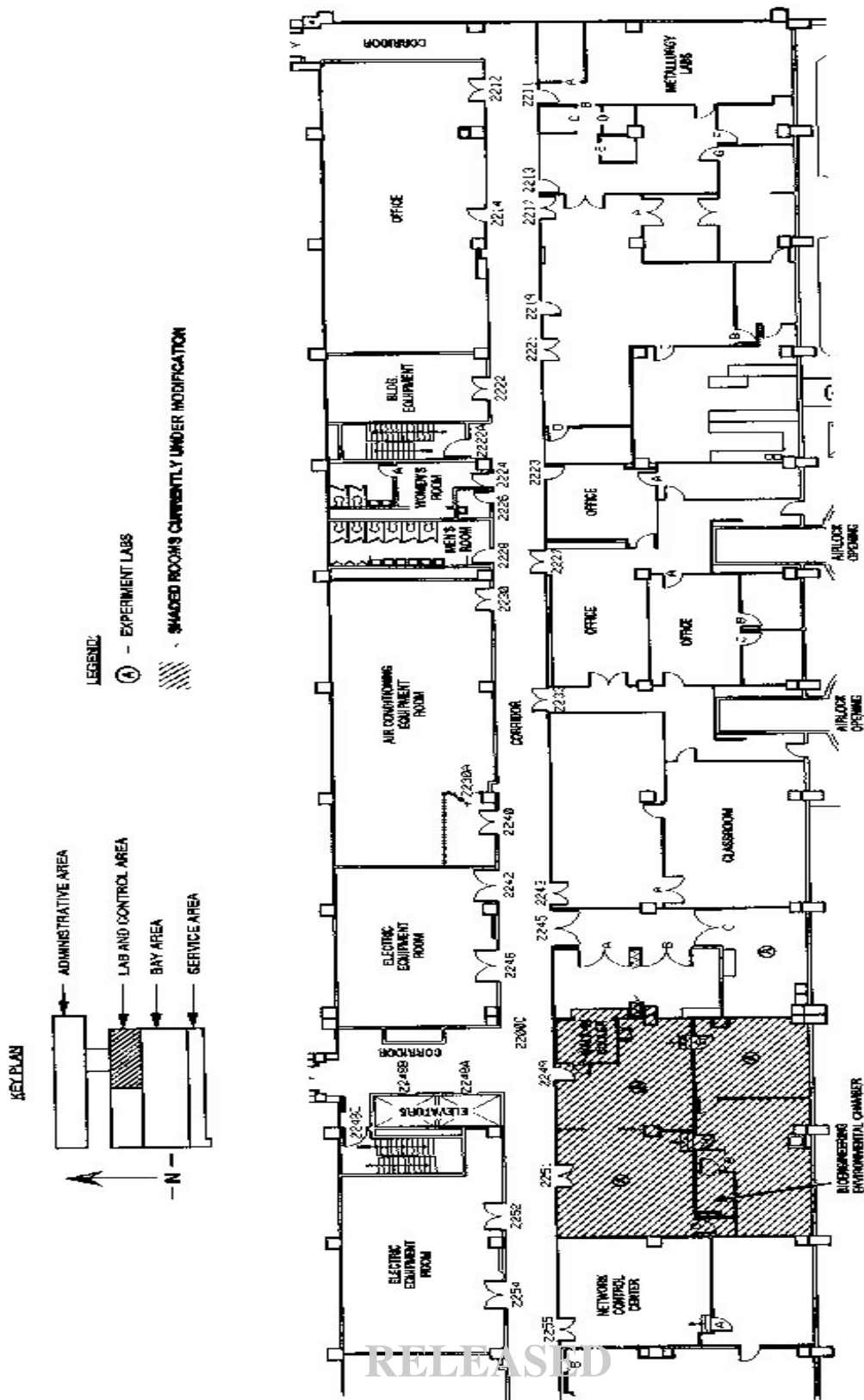

Figure 5-3. Layout of Laboratories and Shops, Second Floor, East O&C Building

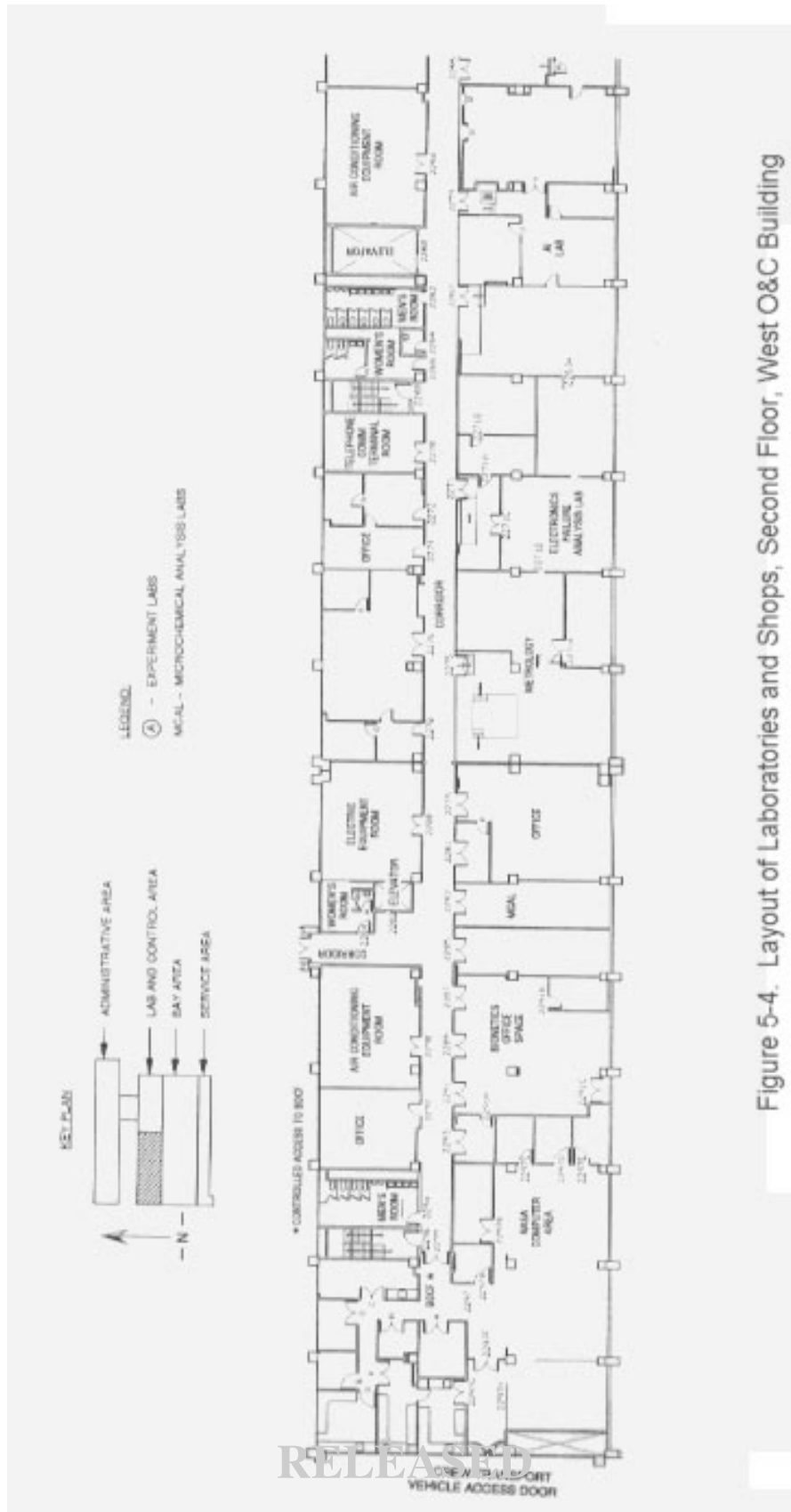

Figure 5-4. Layout of Laboratories and Shops, Second Floor, West O&C Building

K-STSM-14.1.14

Table 5-1. Experiment Laboratory Data

Room Number	Area m ² (ft ²)	Ceiling Height m (ft)	Equipment and Services
1277 (Figure 5-5)	74.3 (800)	3.4 (11)	<ul style="list-style-type: none"> - Special purpose P/L ops - Class 10K clean work area - 120/208-V ac; 60-Hz; 1-Ø & 3-Ø; 15-A, 20-A & 30-A receptacles - 1.8-m (5-ft 9-in) x 2.1-m (6-ft 11-in) double door to 10K clean work area
1289 C-G (Figure 5-6)	208.1 (2240)	2.7 (9)	<ul style="list-style-type: none"> - Double door airlock - Temp & humidity control - 34.8-m² (375-ft²) locked room - 2.3 x 7.6-m (7.5 x 25-ft) chamber for camera calib or film loading (rf shielded) - sink (room F only) - 480-V ac; 60-Hz; 3-Ø; 60-A (1287). 120/208-V ac; 60-Hz; 1-Ø & 3-Ø; 15-A, 20-A & 30-A receptacles - Access to all rooms through 1289 - 60.9-cm (24-in) raised floor - Class 100K clean area
1292 (Figure 5-6)	87.1 (937)	3.4 (11)	<ul style="list-style-type: none"> - 120/208-V ac; 60-Hz; 1-Ø & 3-Ø; 15-A, 20-A & 30-A receptacles - 1.8-m (5ft 11-in) W x 2.1-m (6-ft 11-in) high door clearance - Class 100K clean area
1295	128.6 (960)	3.7 (12)	<ul style="list-style-type: none"> - personnel shower and eye wash station - two exhaust hoods on west wall - Class 50K clean area
1469	259 (2784)	Hook Hgt: 3.7 (12)	<ul style="list-style-type: none"> - Receiving and inspection - 4.6-m x 4.6-m (15-ft x 15-ft) sliding door to area (1) - 4.6-m x 4.6-m (15-ft x 15-ft) sliding door to outside (1) - 3.6-m ton (4-ton) monorail crane

RELEASED

Table 5-1. Experiment Laboratory Data (Continued)

Room Number	Area m ² (ft ²)	Ceiling Height m (ft)	Equipment and Services
1485 (Figure 5-7) (on-line rack integration as primary function)	162.2 (1746)	4.6 (15) Hook Hgt: 3.5 (11.5)	<ul style="list-style-type: none"> - Rack staging area - Comp air at 8.6 bars (125 lb/in²) gage IRIG A timing - 4.6 x 4.6-m (15 x 15-ft) sliding door for access to area (1) - 4.6 x 4.6-m (15 x 15-ft) sliding door to outside is sealed - 120/208-V ac, 60-Hz, 1-Ø & 3-Ø , 15-A & 30-A; 480-V ac, 60-Hz, 3-Ø , 60-A & 100-A receptacles - 1.8-m ton (2-ton) bridge crane - Class 100K clean area
1489	135.2 (1455)	12 (4.0)	<ul style="list-style-type: none"> - Rack staging area - 3 vents to outside with same fittings as room 1485 IRIG A timing - Comp air at 8.6 bars (125 lb/in²) 120/208-V ac; 60-Hz; 1-Ø & 3-Ø ; 15-A, 30-A & 60-A receptacles - 1.8-m (6-ft) W x 3.1-m (10-ft) H door to area; 3.1-m x 3.1-m (10-ft x 10-ft) door to outside (south) - Sink - GN₂ service panel - Class 100K clean area
2245 (figure 5-8)	284.4 (933)	3.4 (11)	<ul style="list-style-type: none"> - 3 individually air-conditioned areas - Class 100K clean area - Laminar flow bench - Dark room capabilities (room 2245C) - Double sink with hot & cold water (2245B) - Wall and base cabinets - 120-V ac; 60-Hz; 1-Ø & 3-Ø ; 15- A & 30-A duplex receptacles

RELEASED

K-STSM-14.1.14

Table 5-1. Experiment Laboratory Data (Continued)

Room Number	Area m ² (ft ²)	Ceiling Height m (ft)	Equipment and Services
2249 2251 (figure 5-8)	214.3 (703) 610.8 (2004)	3.4 (11) & 2.7 (9)	<ul style="list-style-type: none"> - 3.1 x 3.1-m (10 x 10-ft) walk-in refrigerator - 1.8 x 3.4-m (6 11-ft) temp & humidity controlled environmental chamber - 1.4-m (4-ft 8-in) W x 2.1-m (6-ft 11-in) H doorway 2 sinks 60.9-cm (24-in) raised floor in rear 120/208-V ac; 60-Hz; 1-Ø & 3-Ø; 15-A, 20-1 & 30-A power - Class 100K clean area

RELEASED

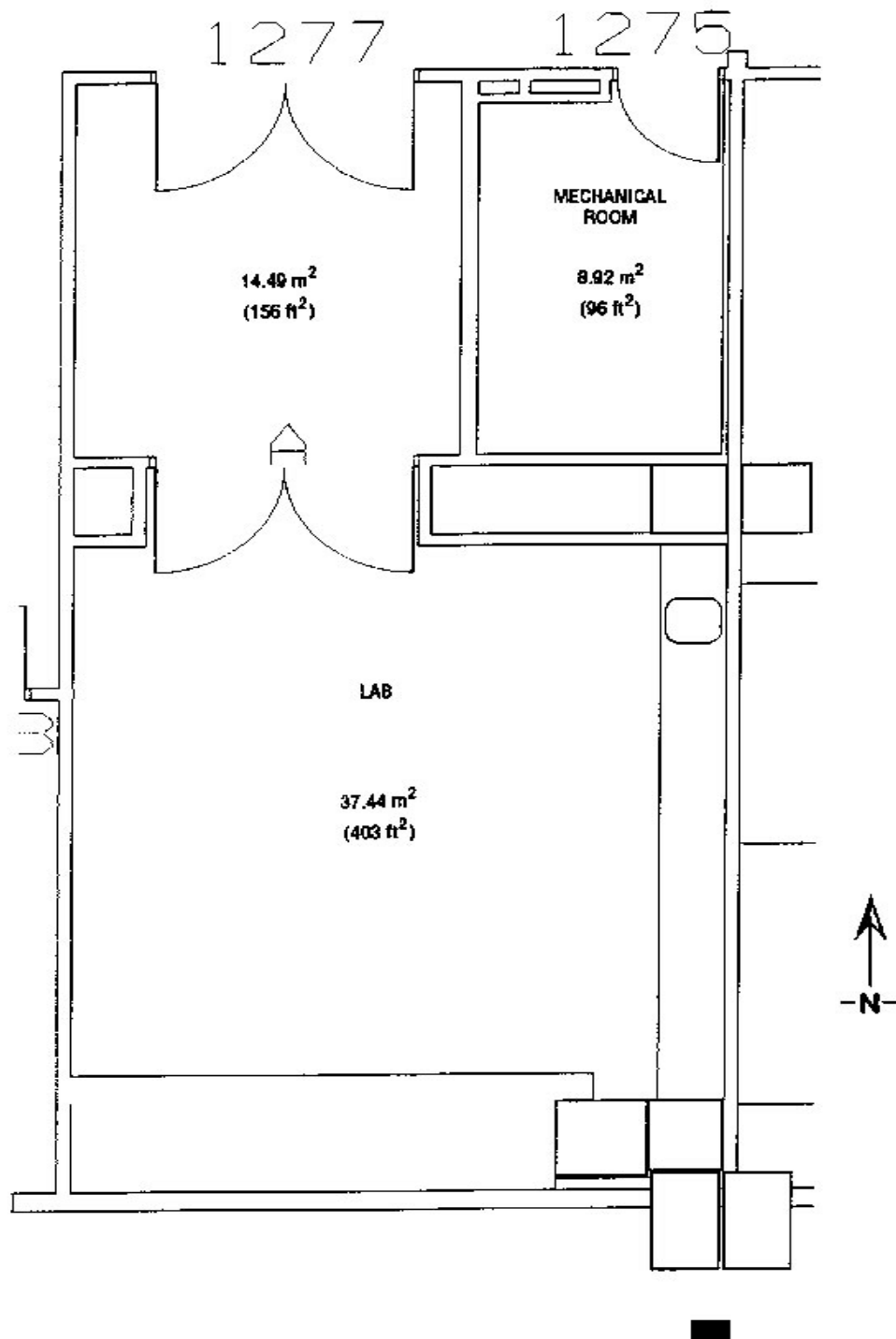

Figure 5-5. Special Purpose Laboratory, Room 1277

K-STSM-14.1.14

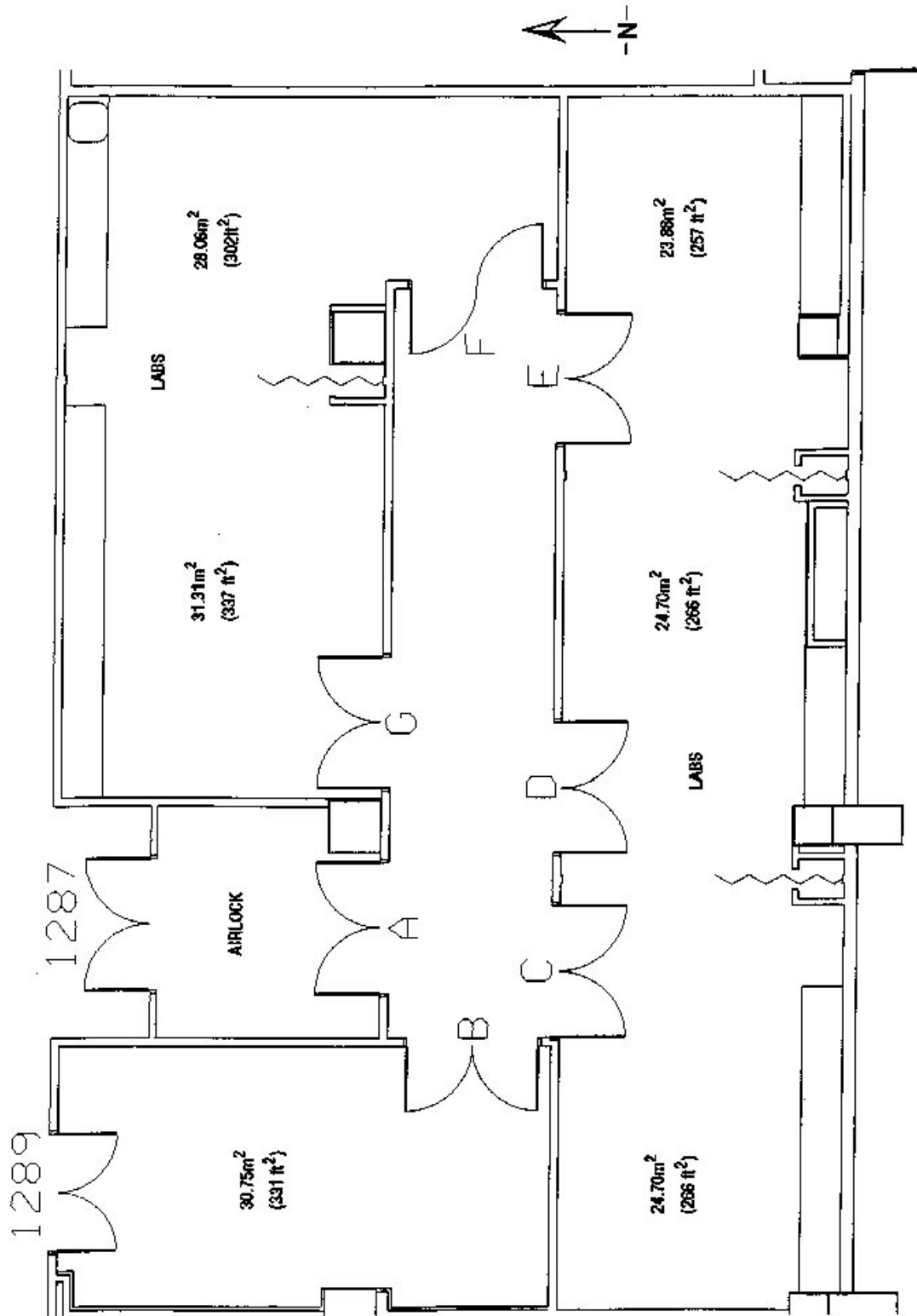

Figure 5-6. 1289 Complex

RELEASED

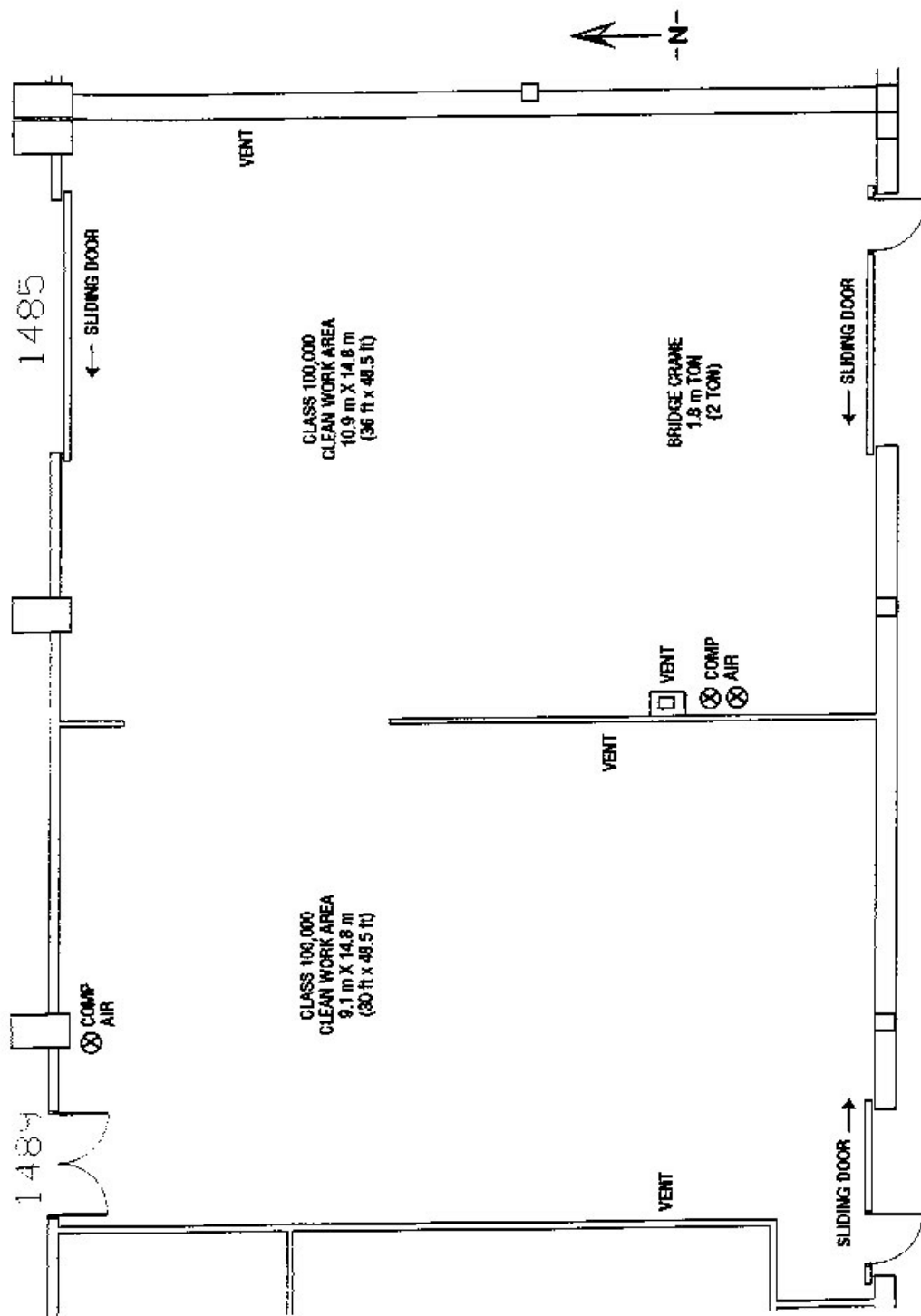

Figure 5-7. Large Experiment Laboratories, Rooms 1485-1489

RELEASED

K-STSM-14.1.14

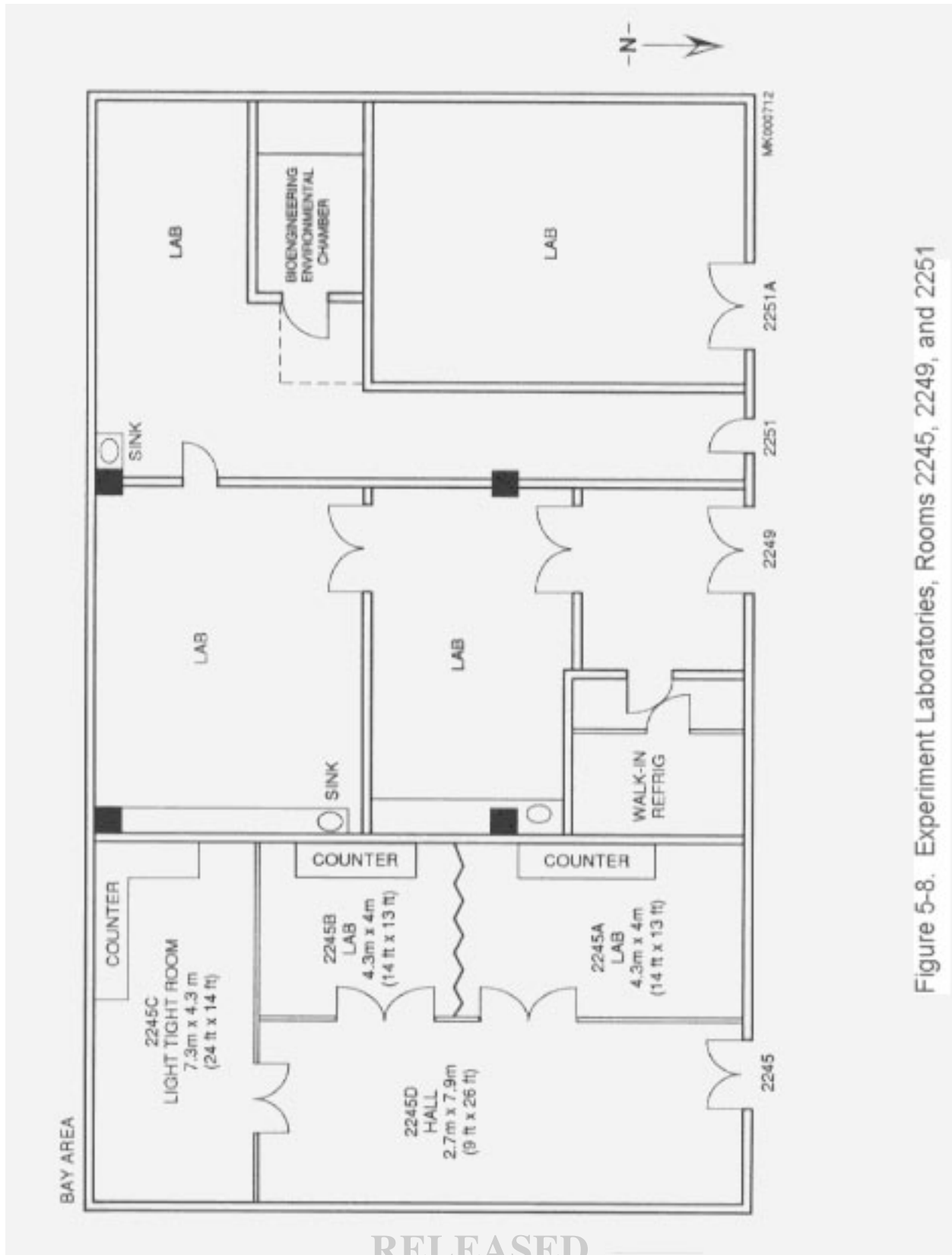

Figure 5-8. Experiment Laboratories, Rooms 2245, 2249, and 2251

RELEASED

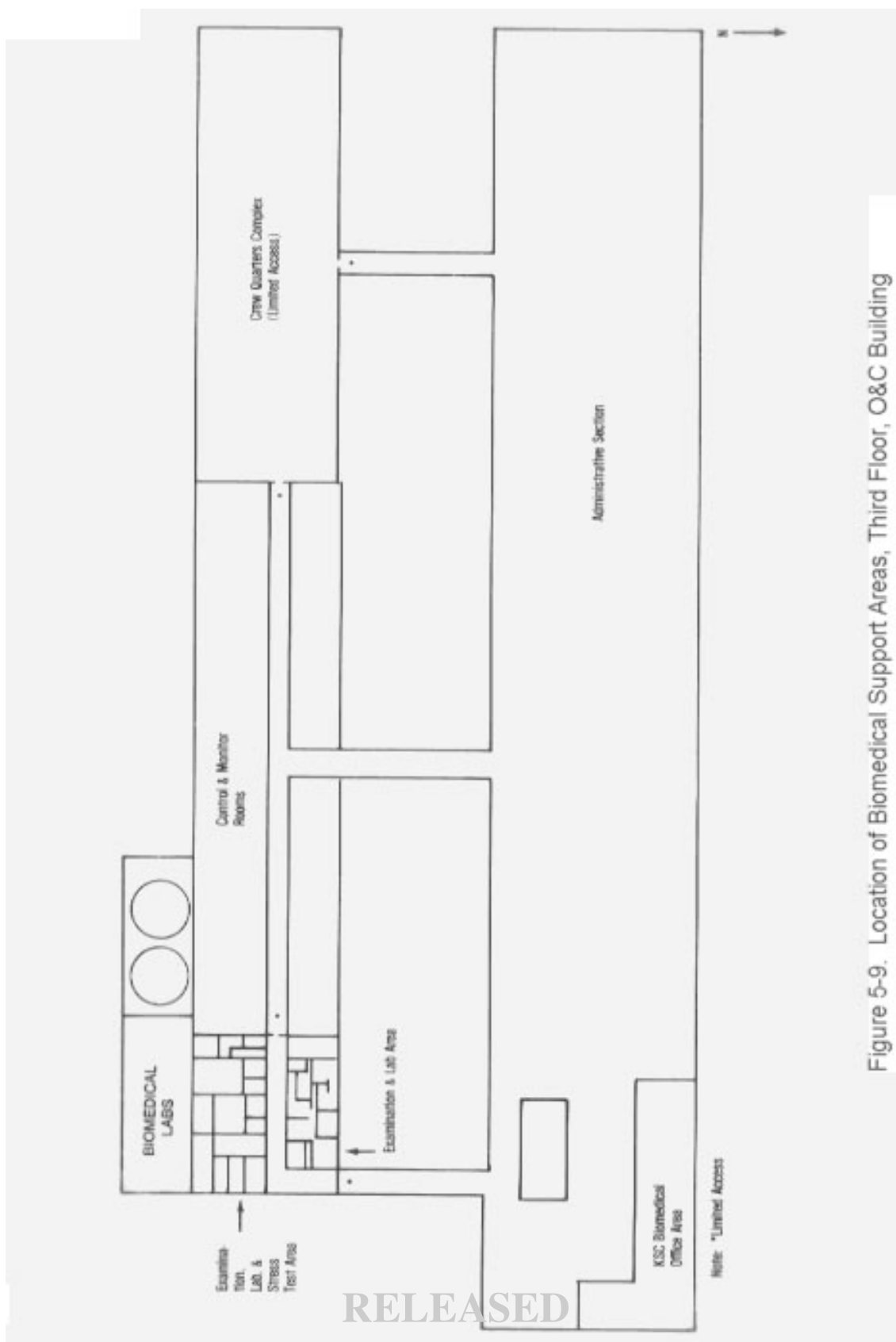

Figure 5-9. Location of Biomedical Support Areas, Third Floor, O&C Building

K-STSM-14.1.14

5.3 BIOMEDICAL SUPPORT AREAS

5.3.1 GENERAL OPERATIONS. On the third floor of the O&C Building on the southeast end are the biomedical examination and laboratory areas. See figure 5-10.

Rooms 3211 through 3220 (figure 5-10) contain medical facilities and laboratories that may be used by the investigators on a pre-arranged and shared basis. The specific rooms and their purposes are:

- a. Room 3211, physical exam room (office)
- b. Room 3212, clinical physical examination
- c. Rooms 3213 and 3214, clinical labs
- d. Room 3219, biomedical lab
- e. Room 3220, bio-instrumentation, electronics, and mechanical fabrication

Availability of selected areas within the Medical Suite is subject to the approval of the Director, Biomedical Operations and Research Office.

5.3.2 ROOM 3211. This room is designated for physical exams, or technical office space.

5.3.3 CLINICAL PHYSICAL EXAMINATION ROOM. A private, standard medical examination can be conducted in room 3212. Standard physicians examining instruments are available plus those items listed in table 5-2.

5.3.4 SPECIAL LABORATORIES. Room 3219 contains the cardiovascular-pulmonary stress test equipment, listed in table 5-3. Rooms 3215A and 3215B contain the data support equipment, which is detailed in table 5-4.

Telephones and OIS units (Room 3215 only) are available in each room. 120/208-V ac, 60-Hz power is available in each room through 1-Ø, 15-A, 20-A, and 30-A receptacles.

RELEASED

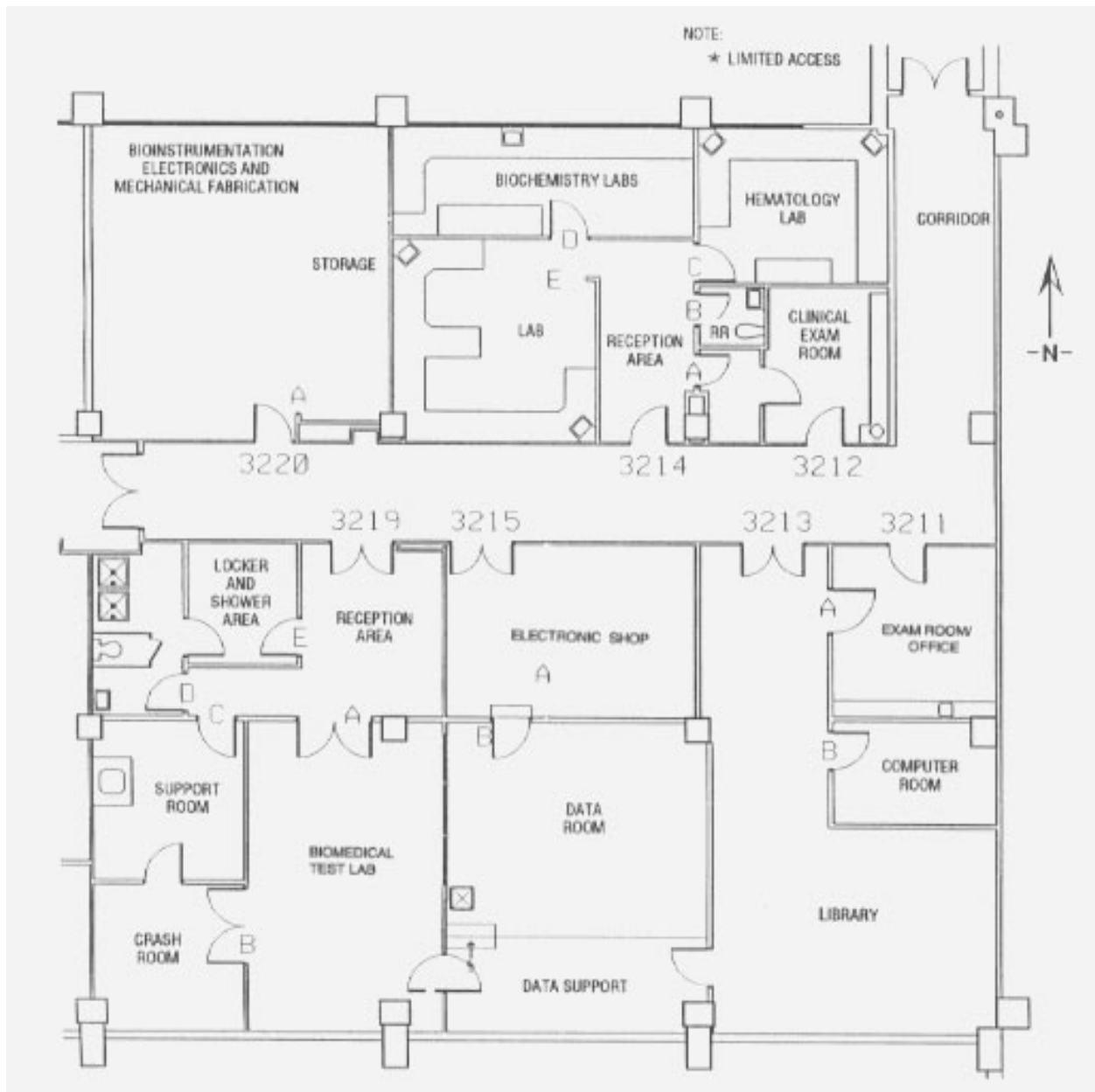

RELEASED

Figure 5-10. Human Life Sciences Support Areas

K-STSM-14.1.14

Table 5-2. Examining Room Equipment

Equipment	Manufacturer Model Number	Capability
Examining table	Ritter	Full body examining table with head up or down, raise & lower right and left rotation, & gynecological stirrups
ECG	Cambridge model 3038/2	Electrocardiography
Scales	Chatillon counter- balance	Weighing
Light box	Halsey	Viewing x-rays
Armed chair		Blood drawing

Table 5-3. Stress Laboratory Equipment

Equipment	Manufacturer, Model Number
Treadmill	Quinton 18-60
ECG monitor	Quinton Q-4000
Metabolic measurement cart	Beckman
Spirometer	Eagle I - Collins
Data acquisition unit 1	Fluke 1752
Data acquisition unit 2	Digitec data logger 2000

RELEASED

Table 5-4. Stress Laboratory Data Support Equipment

Equipment Type	Description
Strip chart recorders	<ul style="list-style-type: none"> o Brush, Mark 200, 8-channel o Brush, Mark 200, 8-channel (Biomed Special) o Gould, 2-channel portable
Analog tape recorders	<ul style="list-style-type: none"> o Ampex 1-in 14-track - 2230 o Honeywell 14-channel - 1 inch
Data acquisition system components	<ul style="list-style-type: none"> o IBM PC-AT with printer, Bernoulli, modem o Fluke 1752A
Digital processing oscilloscopes	<ul style="list-style-type: none"> o Norland 3001 mainframe o Data acquisition modules (2), 4 channels total
Data terminals	<ul style="list-style-type: none"> o Standard PON network
Gas analyzer systems	<ul style="list-style-type: none"> o Beckman Metabolic Measurement Cart (MMC) with M6800 driven interface module providing RS232 signal to IBM PC-AT computer system. MMC can be operated remotely via 1200-baud modem. o Beckman Horizon Gas Analysis Cart
General purpose equipment	<ul style="list-style-type: none"> o Tektronix oscilloscopes & camera o Lifepak 5 defibrillator (3) o Ohmeda oximeter o Function generators o DVMs, DMMs o Counters

Just off the stress lab to the west is a crash room equipped with the following items:

- a. Examining table
- b. Laerdal suction units (2)
- c. Life Pak 5 cardiac defibrillation device
- d. Gurney
- e. Breathing oxygen, Robertshaw resuscitator-aspirator
- f. Hope II portable adult resuscitators (2), Ohio Medical Products
- g. Crash cart with emergency medical supplies
- h. IVAC digital thermometer and charger

RELEASED

K-STSM-14.1.14

Room 3214 contains the hematology, biochemistry, and supplemental laboratories. Table 5-5 lists the hematology equipment; table 5-6, the biochemistry lab equipment; and table 5-7, the supplemental lab equipment (in room 3214).

The Biomedical Support Area contains a locker room and showers in 3219A and a support area with washer, dryer, and refrigerator for perishable drugs.

Table 5-5. Hematology Lab Equipment

Equipment	Manufacturer, Model Number	Capability
Coulter counter	STK-5	PLT, MCH, MCHC, RDW, RBC, WBC, MCV, HCT, Hgb Differential
Blood mixer	Coulter	Mixing of anticoagulated specimens
Hematek stainer	Ames	Staining slides
Microscope	Zeiss	10x & 40x phase lenses 40x & 100x oil immersion
Analytical balance	Mettler AE-200	Exact weighing of reagents
Refrigerated centrifuge	Beckman TR6	Centrifugation of refrigerated specimens for special chemistries
Refrigerated centrifuge	Mistral 3000	Centrifugation of refrigerated specimens for special chemistries

RELEASED

Table 5-6. Biochemical Lab Equipment

Equipment	Manufacturer, Model Number	Capability
Spectrophotometer	Perkin-Elmer Turner	Transmittance & absorbance of solutions
Complete electro-phoresis - Variable power supply with power cells - Incubator oven - 720 fluorometer-densitometer - Data terminal	Corning	Separation of proteins, lipoproteins, CK & LDH isoenzymes, haptoglobins, hemoglobins, glycosylated hemoglobins Analysis of electrophoretic patterns- Calculation & printout
Digital analyzer pH meter	Orion	pH of solutions
Hot plate stirrer	Corning	Mixing of reagents
Vortex mixer	Scientific Products	Mixing of reagents
Multi-timer	Coutler	Simultaneous timing of many tests
Water bath	Precision	Maintenance of specific temperature for reagents
Gamma counter	Packard, Crystal Plus	Counting radioactive material
HPLC System	Waters	Analyses of body fluids for amino acids, catecholamines, proteins
Vacuum Pump	Precision Model DD195	Removal of reagents
Automatic Clinical Analyzer	Dimension AR	45 Chemical Analyses

RELEASED

K-STSM-14.1.14

Table 5-7. Supplemental Lab Equipment

Equipment	Manufacturer Model Number	Capability
Large 3-door refrigerator	Revco	Refrigeration of specimens
Safety Storage Cabinet	Justrite	Housing of flammables
Corrosive Storage Cabinet	A&A Products	Housing of acids
Automatic ice maker	Scotsman	Production of ice cubes
Refrigerator 0.34 m ³ (15 ft ³)	Precision	Secured storage - flammable
Refrigerator 0.43 m ³ (12 ft ³)	GE	Secured storage
Deep freeze (ultra cold)	Revco	Temperatures as low as -56.7 degrees C (-70 degrees F) for freezing samples

5.3.5 BASELINE DATA COLLECTION FACILITY (BDCF).

5.3.5.1 General Information. Rooms 2293 through 2299, second floor, west side are designated as the BDCF. This 427.5-m² (4600-ft²) area is used to conduct ground-based tests equivalent to the in-flight protocols for non-invasive human life sciences flight experiments. The BDCF is located beneath the Crew Quarters for ease of access and proximity. Data are collected before, during, and after flight, if required. Figure 5-11 shows the basic layout of the BDCF and table 5-8, the data on each room in the facility.

The environment within the BDCF is maintained between 17 degrees and 27 degrees C (61 degrees and 80 degrees F). Relative humidity is maintained between 35% and 70%. The area is kept visibly clean. The flooring is vinyl asbestos tile; the wall surface is a washable off-white smooth finish. General lighting provides 8.1 to 9.1 lm/m² (75 to 85 fc) with a controllable dimmer switch. Battery powered lights are available for emergency lighting. The noise level within the BDCF can be maintained to less than 65 dBA.

Telephones and OIS units (Room 2297-F only) are available in each room. 120/208-V ac, 60-Hz power is available in each room through 1-Ø and 3-Ø, 15-A, 20-A, and 30-A receptacles. On the southwest corner of the BDCF are folding walls for flexible use of the area.

RELEASED

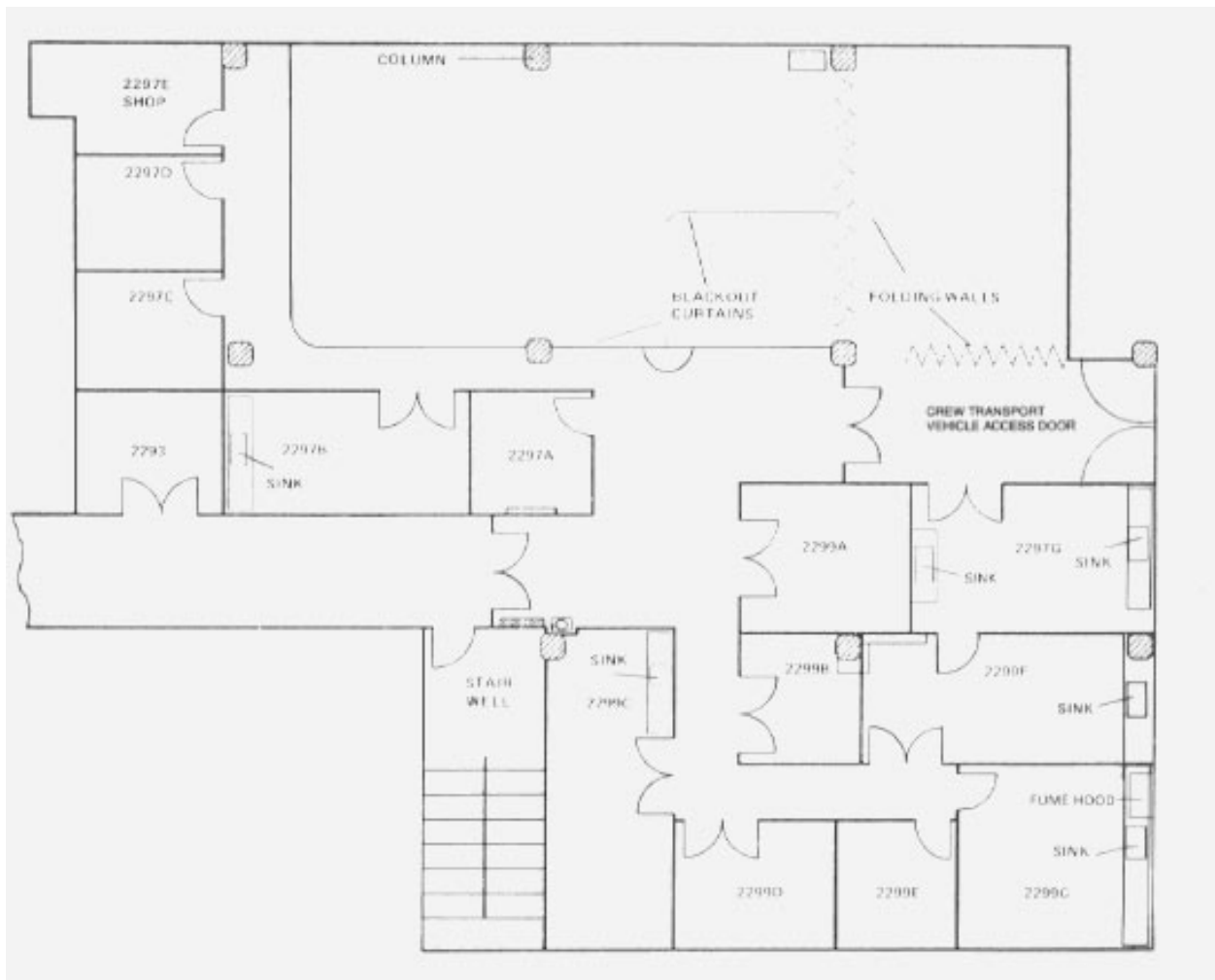

RELEASED
Figure 5-11. BDCI Layout

K-STSM-14.1.14

Table 5-8. BDCF Data

Room Number	Size m (ft-in)	Ceiling Hgt. m (ft-in)	Door Opening m (ft-in)	Special Equipment and Services
2293	3.1 x 3.7 (10 x 12)	3.4 (11)	1.7 x 2.4 x 7-11.5) (5-7	– Office area - Nurses
2297	21.0 x 9.1 (69 x 30)	3.4 (11)	1.7 x 2.4 x 7-11.5) (5-7	– Data lines to user rooms on 4th floor
2297A	3.1 x 3.1 (10x10)	3.4 (11)	1.1 x 2.4 x 7-11.5) (3-9	
2297B	3.1 x 6.1 (10 x 20)	3.4 (11)	1.7 x 2.4 x 7-11.5) (5-7	– Lab sink and cabinets
2297C	2.9 x 3.7 (9.5 x 12)	3.4 (11)	0.9 x 2.4 x 7-11.5) (3-3	
2297D	2.9 x 3.7 (9.5 x 12)	3.4 (11)	1.1 x 2.4 x 7-11.5) (3-9	
2297E	2.7 x 3.7 (9x12)	3.4 (11)	1.1 x 2.4 x 7-11.5) (3-9	
2297G	3.7 x 3.7 (12x12)	2.9 (9.5)	1.7 x 2.4 x 7-11.5) (5-7	– Lab sink and cabinets
2299A	3.7 x 4.3 (12 x 14)	2.9 (9.5)	1.7 x 2.4 x 7-11.5) (5-7	
2299B	2.9 x 3.1 (9.5 x 10)	2.9 (9.5)	1.7 x 2.4 x 7-11.5) (5-7	
2299C	3.1 x 7.9 (10 x 26)	3.7 (12)	1.7 x 2.4 x 7-11.5) (5-7	– Lab sink and cabinets
2299D	3.1 x 4.0 (10 x 13)	2.9 (9.5)	1.7 x 2.4 x 7-11.5) (5-7	
2299E	3.1 x 3.1 (10 x 10)	2.9 (9.5)	1.1 x 2.4 x 7-11.5) (3-9	
2299F	3.1 x 7.3 (10 x 24)	2.9 (9.5)	1.7 x 2.4 x 7-11.5) (5-7	– Lab sink and cabinets
2299G	4.6 x 4.9 (15 x 16)	2.9 (9.5)	1.1 x 2.4 x 7-11.5) (3-9	– Lab sink and cabinets

RELEASED

5.4 MATERIAL SCIENCE LABORATORIES

5.4.1 GENERAL DESCRIPTION. The material Science Laboratories are located on the first and second floors of the O&C Building. These labs are used for non-routine material testing, microchemical analysis, and malfunction investigations in support of Shuttle launches and KSC operations. These labs are staffed by civil service personnel who are professionals in the disciplines of chemical analyses, physical and mechanical properties, evaluations, and malfunction investigations. These services are available to support payload activities.

Requests for material testing and microchemical analysis support are submitted on KSC Form 22-81, Task Request. Failure analysis support is requested on KSC Form 11-107, KSC Failure Analysis Report.

The laboratories can be divided into three types: Malfunction Analysis, Material Testing, and Microchemical Analysis Laboratories (MCAL). For purposes of this document, the Malfunction and Material Analysis Laboratories (MMAL) are presented together. The functions of these laboratories are as follows:

- a. Microchemical Analysis Laboratory (DM-MSL-1) - Determines the chemical composition of any substance. Answers the questions, "What is it and where did it come from?" Also performs chemical studies to solve process problems
- b. Materials Testing Laboratory (DM-MSL-2) - Responsible for environmental (humidity, altitude, temperature, high vacuum, vibration, shock), physical (tensile, shear, compression, chemical compatibility, flammability, electrostatic, thermal analysis, LOX impact), and research and consulting on coatings
- c. Malfunction Analysis Laboratory (DM-MSL-3) - Designated KSC failure analysis laboratory. Has capability for metallurgical, pneumatic, hydraulic, mechanical, electrical, electronic, and metrological investigations

More detailed information on these labs is contained in GP-1032, *Material Analysis Office Capability Manual*.

5.4.2 MMAL. Table 5-9 lists the locations and space for the first floor MMAL's. Table 5-10 lists the second floor MMAL's.

RELEASED

K-STSM-14.1.14

Table 5-9. MMAL Locations and Space, First Floor, O&C Building

Room Number	Use Description	Space	
		m ²	ft ²
1213	Plastics and polymers processing	86.3	(929)
1213A	Shock equipment and vibration controls	65.6	(706)
1213B	Vibration tables	29.3	(315)
1218	MSL-2 office	47	(505)
1219	Material test staging and equipment storage	34.1	(367)
1219A	Electronic Test Equipment	55.7	(600)
1219B	Environmental test chambers	65.1	(700)
1219C	Material test sample preparation	30.5	(328)
1227	Clean room filter bank (with laminar flow controls)	80.8	(870)
1229	Dissection disassembly	41.3	(445)
1233	Fluids/Mechanical laboratory	111.1	(1196)
1233A	Large component disassembly area	16.4	(176)
1233B	Pneumatic test	41.3	(445)
1233C	X-ray fluoroscope	16	(172)
1233D	Class 100 clean room (same as 1227)	70.1	(755)
1234	MSL office	57.9	(621)
1235	Hydraulic test console	17.6	(189)
1235A	Hydraulic pump unit	11.05	(119)

RELEASED

**Table 5-10. MMAL Locations and Space, Second Floor,
O&C Building**

Room Number	Use Description	Space	
		m ²	ft ²
2211-13	Photomicrography and metallographic viewing	58.3	(627)
2211-13A	Electrochemical processing	8.8	(95)
2211-13B	Photomicrography and photography	12.8	(138)
2211-13C	Darkroom	3.0	(32)
2217 -19-21	MSL-3 office	98.2	(1057)
2217B	Specimen dissection and preparation	13.5	(145)
2221	Polymers and lubricant entry hall	98.2	(1057)
2271	Electronics laboratory entry hall	24.9	(268)
2271A	Microelectronics and digital electronics failure analysis	18.4	(198)
2271B	Microelectronics and radio frequency analysis	27.7	(298)
2275	Metrology and power electronics failure analysis (electrical power lab)	153.2	(1649)
2275A	Electrical properties test	26.7	(287)

RELEASED

K-STSM-14.1.14

5.4.2.1 Electrical Power Laboratory. Rooms 2275 and 2275A contain the equipment listed in table 5-11.

Table 5-11. Electrical Power Laboratory Equipment

Item	Manufacturer	Model No.
Variable filters	Allison Labs, Inc.	2ABR
Digital recorder	Hewlett-Packard	H25562A
Digital recorder	Hewlett-Packard	M71562A
DC power supply	Sorensen	DCR 40-35
Distortion analyzer	Hewlett-Packard	331A
DC digital voltmeter	Hewlett-Packard	40SCR
Digital recorder	Hewlett-Packard	561B
Pulse generator	Rutherford Electronics Co.	B15R
DC power supply	NJE Corporation	CR-36-8
DC voltmeter	Lambda Electronics Corporation	C-881M-0178
AC-DC converter	Hewlett-Packard	457A
Low-frequency function generator	Hewlett-Packard	202A
Digital voltmeter	Non-Linear Systems, Inc.	484
Phase angle voltmeter	North Atlantic Industries, Inc.	VM301-51047
Dielectric breakdown tester	Industrial Instruments	PA-5
Triboelectric tester	--	--
Power supply	Trygon Electronics	M36-25 OV5289
Potentiometer	Leeds and Northrup Co.	7554 type K-4
Oscilloscope	Hewlett-Packard	140A

RELEASED

**Table 5-11. Electrical Power Laboratory Equipment
(Continued)**

Item	Manufacturer	Model No.
Chamber assembly -vacuum drying	McDonnell	52EA20167-1
Decade resistor	General Radio	1432-X
DC null detector	Leeds and Northrup Co.	983r
D100E noise analyzer	Quan-Tech Laboratories	327
Transistor noise analyzer	Quan-Tech Laboratories	310
Transistor noise analyzer	Quan-Tech Laboratories	2173C
Integrated circuit noise analyzer	Quan-Tech Laboratories	2283
AC-DC volt-ammeter	Sensitive Research	UVA
Digital multimeter	Calico Instruments Corporation	8000
Regulated power supply	Lambda Electronics Corporation	LH-124FM
Ultrasonic cleaner	Buehler	75-1950
Mobile test unit	Rubicon Instruments	2773
Preset counter	Berkley	5425
Generator load bank	Sun Electronics	GLB3A
Digital recorder	Hewlett-Packard	560A

RELEASED

K-STSM-14.1.14

5.4.2.2 Electronics Laboratories.

- a. Microelectronics and Digital Electronics Area. Table 5-12 lists the Microelectronics and Digital Electronics Area equipment.

Table 5-12. Microelectronics and Digital Electronics Area Equipment

Item	Manufacturer	Model No.
Minicomputer (96K memory)	DEC	PDP-11/35
Microcomputer	IBM	AT
Disk drives (2)	DEC	RK05
Cassette drive	DEC	TA11-AA
Floppy disk drive	DEC	RX11-BA
Terminal printer	Diablo	1620-3
CRT terminal	DEC	VT55
Graphics terminal	Tektronix	4012
Ward copier	Tektronix	4610
Digital processing oscilloscope	Tektronix	7704
Transient digitizer	Tektronix	7912
Digital voltmeter	Hewlett-Packard	3440A
Counter	Hewlett-Packard	5245L
Scanner	Hewlett-Packard	3495-A
Digital multifunction meter	Hewlett-Packard	3450
Test oscillator	Hewlett-Packard	651B

RELEASED

Table 5-12. Microelectronics and Digital Electronics Area Equipment (Continued)

Item	Manufacturer	Model No.
Power supply	Hewlett-Packard	6824A
Precision amplifier	Hewlett-Packard	463A
DC millimeter	Hewlett-Packard	428A
Digital recorder	Hewlett-Packard	5050B
Pulse generator	Hewlett-Packard	8015A
Pulse generator	Hewlett-Packard	8082A
Curve tracer	Tektronix	577-177/178
Transistor bias supply	Hewlett-Packard	8717B
Logic analyzer	Hewlett-Packard	5000A
DC differential voltmeter	Hewlett-Packard	740B
Digital voltage source	--	6129C
Constant-amplitude signal generator	Tektronix	191
Mark time generator	Tektronix	184
Integrating digital voltmeter	Dymec	2401B
Impedance bridge	General Radio	1608A
Megohm bridge	General Radio	1644A
Logic analyzer	Tektronix	7001/DF1
Microelectronic test station	Wentworth	--

RELEASED

K-STSM-14.1.14

Table 5-12. Microelectronics and Digital Electronics Area Equipment (Continued)

Item	Manufacturer	Model No.
Optical recorder	CEC	5-133
Vacuum oven	Cole Palmer	--
Dual-beam general-purpose oscilloscope	Tektronix	555
Random noise generator	General Radio	1390B
Test oscillator (10 Hz to 10 MHz)	Hewlett-Packard	625A
Distortion analyzer	Hewlett-Packard	334A

- b. RF-Microelectronics Laboratory. Table 5-13 lists the RF-Microelectronics laboratory equipment.

Table 5-13. RF-Microelectronics Laboratory Equipment

Item	Manufacturer	Model No.
Digital voltmeter	Hewlett-Packard	3440
Memory oscilloscope	Tektronix	549
Transistor curve tracer	Tektronix	575
Television waveform monitor	Tektronix	525
RF sweep oscillator with plug-ins (400 kHz to 12.4 GHz)	Hewlett-Packard	8690
Random noise generator	General Radio	1390B

RELEASED

Table 5-13. RF-Microelectronics Laboratory Equipment (Continued)

Item	Manufacturer	Model No.
Test oscillator (10 Hz to 10 MHz)	Hewlett-Packard	652A
Preset counter	Computer Measurements	776C
DC Standard	Hewlett-Packard	740B
High-frequency signal generator (50 kHz to 65 MHz)	Hewlett-Packard	606
VHF signal generator (10 to 480 MHz)	Hewlett-Packard	608
UHF signal generator (450 to 1230 MHz)	Hewlett-Packard	612
UHF signal generator (800 to 4200 MHz)	Hewlett-Packard	614A
Pulse generator	Hewlett-Packard	214A
Low-frequency function generator with plug-ins	Hewlett-Packard	3300
Super-high frequency signal generator (3.8 to 11 GHz)	Hewlett-Packard	618B
FM-am signal generator (195 to 270 MHz)	Hewlett-Packard	202J
FM-am signal generator (54 to 216 MHz)	Hewlett-Packard	202E
Telechrome test signal generator	Telemat Co.	3508
Wave analyzer	Hewlett-Packard	302

RELEASED

K-STSM-14.1.14

Table 5-13. RF-Microelectronics Laboratory Equipment (Continued)

Item	Manufacturer	Model No.
Megohm bridge	General Radio	1644A
Ratioarm capacitance bridge	General Radio	1608
Ratioarm impedance bridge	General Radio	1608
Distortion analyzer	Hewlett-Packard	334A
Phase meter	Action Laboratories	320-AB
Microwave power meter	Hewlett-Packard	431B
Peak power calibrator	Hewlett-Packard	434A
Network analyzer	Hewlett-Packard	8407A
Microwave network analyzer	Hewlett-Packard	8401A
Phase-gain indicator	Hewlett-Packard	81413A
Reflection-transmission test unit	Hewlett-Packard	8743A
S-parameter test set	Hewlett-Packard	8745A
Sweet oscillator	Hewlett-Packard	6920
Delay line	Hewlett-Packard	1100A
Microwave frequency converter	Hewlett-Packard	2590
Recorder chart, 8-channel	Sanborn	7700
Counter	Hewlett-Packard	5211B
Frequency comparator	Montronics	100
Power supply, dc	Hewlett-Packard	6824A 2
AC-dc converter	Hewlett-Packard	457A 1
Vector voltmeter	Hewlett-Packard	8405 1

RELEASED

Table 5-13. RF-Microelectronics Laboratory Equipment (Continued)

Item	Manufacturer	Model No.
Microwave frequency converter	Hewlett-Packard	2590 1
Digital voltmeter, integrating	Hewlett-Packard	2401 1
AC-ohms converter	Hewlett-Packard	2410B 1
Frequency meter	Hewlett-Packard	500BR
Frequency oscillator	General Radio	1115-B
Digital comparator	Dymec	2532A
Data amplifier	Dymec	2411A 1
Radio metallic micro-scope	Barnes Engineering	1
Programmable DC load bank	Kikisui	P2 1000W
Video editing system	Panasonic	AGA650
Microscope video system	Circon	MV9630
Logic analyzer	Hewlett-Packard	16500A
AC-DC hipot tester	Hipotronics	HC3-AT-AD

5.4.2.3 Environmental Testing Laboratory. Table 5-14 list the Environmental Testing Laboratory equipment.

Table 5-14. Environmental Testing Laboratory Equipment

Item	Manufacturer	Model No.
High-frequency vibration system	Unholtz Dickie	TA145A-1301AR
High temperature ovens	Blue M	POM-256E
Temperature-altitude chamber	Thermotron	FA-96-CH-15-15-5
Temperature-humidity chamber	Thermotron	WP-867-705-THCM2

RELEASED

K-STSM-14.1.14

Table 5-14. Environmental Testing Laboratory Equipment (Continued)

Item	Manufacturer	Model No.
High-vacuum system	Slack Inc.	--
Portable vacuum system	--	--
Salt spray chamber	Atlas	SF 2000
Dewpoint hydrometer	EG&G	992-C1
Optical pyrometer	Leeds & Northup Co.	8641

5.4.2.4 Fluid Mechanical Laboratories.

- a. Pneumatics Laboratory. Table 5-15 lists the Pneumatics Laboratory equipment.

Table 5-15. Pneumatics Laboratory Equipment

Item	Manufacturer	Model No.
Pneumatics panel, 206.7 bars (0 to 3000 lb/in ² gage)	NASA, KSC	--
Pneumatics panel, 17.2 bars (0 to 250 lb/in ² gage)	NASA, KSC	--
Pneumatics panel, 6.9 bars (0 to 100lb/in ² gage)	NASA, KSC	--
Test chamber	NASA, KSC	--
Pressure intensifier, 689 bars (0 to 10,000 lb/in ² gage)	Futurecraft Corp.	90739
Camera with assorted lenses	Polaroid Corporation	MP-4

RELEASED

Table 5-15. Pneumatics Laboratory Equipment (Continued)

Item	Manufacturer	Model No.
Camera with assorted lenses	Polaroid Corporation	MP-3
Lamp	American Optical Co.	651
Illuminator	American Optical Co.	11-80
Stereozoom 7	Bausch & Lomb, Inc.	312701-424-A
Camera	Polaroid Corporation	545
10X microscope	Spencer	--
2X microscope	Bausch & Lomb, Inc.	--
Illuminator	Cole Parmer	9741-50
Computer	American Research Corp.	Geminix
Printer	Fujitsu	DX2100
Display monochrome	Samsung	SM125539A7
10X microscope	American Optical Co.	--
Optical comparator	Jones and Lamson	TC-10
Digital voltmeter	Hewlett-Packard	3455A
Digital voltage source	Hewlett-Packard	6129C
Scanner	Hewlett-Packard	3495A

RELEASED

K-STSM-14.1.14

Table 5-15. Pneumatics Laboratory Equipment (Continued)

Item	Manufacturer	Model No.
Pressure gage, direct reading, 34.5 bars (0 to 500 lb/in ² gage)	Ruska Instruments Corporation	6010-705-00
Pressure gage, direct reading, 172.3 bars (0 to 2500 lb/in ² gage)	Ruska Instruments Corporation	6010-702-00
Pressure gage, direct reading 3.4 bars (0 to 50 lb/in ² gage)	Ruska Instruments Corporation	6010-701-00
Interface (3)	Ruska Instruments Corporation	6005-701-00
Ohmmeter	Simpson Electric Co.	260
Electronic counter	Simpson Electric Co.	5243L
Digital printer	Anadex	DP-600
Universal counter	Hewlett-Packard	5325B
Electronic counter	Hewlett-Packard	522B
Regulated power supply	Trygon Electronics	MSIt
Regulated power supply	Camboa Electronics Corp	LP-414-FM
Regulated power supply	Lambda	LK343A FM
Digital multimeter (2)	Hewlett-Packard	3438A
Regulated power supply	Camboa Electronics Corp	LP-343A-FM
Power supply	Moxon, Inc.	3540

RELEASED

Table 5-15. Pneumatics Laboratory Equipment (Continued)

Item	Manufacturer	Model No.
Regulator power supply	Raytheon Corp. (Sorensen)	QRC40-4A
Storage oscilloscope	Tektronix	RM564
Oscilloscope camera	Tektronix	C-12
Scope-mobile	Tektronix	Type 201-2, model B
Volt-ohm microammeter	Simpson Electric Co.	269 series 3
Oxygen analyzer	Teledyne Instruments	332B
Ohmmeter	Weston	666
Preset controller	Hewlett-Packard	5331A
1/4-hp vacuum pump	Schuco Scientific	--
X-ray fluoroscope	Picker X-Ray Corp.	CQF17/1023
Edge enhancer	International Imaging Systems	03143-01
Hardness tester	Riehle Testing Machines	CM-4
Electronic counter	Hewlett-Packard	5233L
Oscilloscope	Hewlett-Packard	1980B
Computer	Radio Shack	TRS 80 Model 4
Dot matrix printer	Epson	FX-80
Digital voltmeter	Hewlett-Packard	3439A

RELEASED

K-STSM-14.1.14

Table 5-15. Pneumatics Laboratory Equipment (Continued)

Item	Manufacturer	Model No.
Digital voltmeter	Hewlett-Packard	3440A
Wide-range oscillator	Hewlett-Packard	200CDR
Oscilloscope	Hewlett-Packard	1201B
AC power supply	NASA, KSC	--
Gage, 1.1 bars (0 to 15 lb/in ²) 38.1-cm (15-in) dial	Heise	--
Gage, 1.1 bars (0 to 15 lb/in ²) 33-cm (13-in) dial	Heise	--
Gage, 1.7 bars (0 to 25 lb/in ²) 33-cm (13-in) dial	Heise	--
Gage, 2.1 bars (0 to 30 lb/in ²) 25.4-cm (10-in) dial	Heise	--
Gage, 6.9 bars (0 to 100 lb/in ²) 25.4-cm (10-in) dial	Heise	--
Gage, 6.9 bars (0 to 100 lb/in ²) 33-cm (13-in) dial	Heise	--
Gage, 27.6 bars (0 to 400 lb/in ²) 25.4-cm (10-in) dial	Heise	--
Gage, 41.3 bars (0 to 600 lb/in ²) 25.4-cm (10-in) dial	Heise	--
Gage, 68.9 bars (0 to 1000 lb/in ²) 25.4-cm (10-in)	Heise	--

RELEASED

Table 5-15. Pneumatics Laboratory Equipment (Continued)

Item	Manufacturer	Model No.
Gage, 172.3 bars (0 to 2500 lb/in ²) 33-cm (13-in) dial	Heise	--
Gage, 344.5 bars (0 to 5000 lb/in ²) 25.4-cm (10-in) dial	Heise	--
Gage, 344.5 bars (0 to 5000 lb/in ²) 33-cm (13-in) dial	Heise	--
Gage, 413.4 bars (0 to 6000 lb/in ²) 25.4-cm (10-in) dial	Heise	--
Gage, 689 bars (0 to 10,000 lb/in ²) 25.4-cm (10-in) dial	Heise	--
Gage, 1033.5 bars (0 to 15,000 lb/in ²) 25.4-cm (10-in) dial	Heise	--
Gage, 2.1 bars (0 to 30 lb/in ²) 25.4-cm (10-in) dial	Wallace & Tiernan	FA145-LL01650
Gage, 2.2 bars (0 to 31.5 lb/in ²) 25.4-cm (10-in) dial	Wallace & Tiernan	FA129-LL05692
Gage, 1.6 bars (0 to 24 lb/in ²) 25.4-cm (10-in) dial	Wallace & Tiernan	FA129
Gage, 3.4 bars (0 to 50 lb/in ²) 25.4-cm (10-in) dial	Wallace & Tiernan	FA129
Gage, 55.1 bars (0 to 800 lb/in ²) 25.4-cm (10-in) dial	Wallace & Tiernan	FA129
Gage, 1.1 bars (0 to 15 lb/in ²) 10.2-cm (4-in) dial	Marsh Instrument Co.	210-C

RELEASED

K-STSM-14.1.14

Table 5-15. Pneumatics Laboratory Equipment (Continued)

Item	Manufacturer	Model No.
Gage, 206.7 bars (0 to 3000 lb/in ²) 10.2-cm (4-in) dial	Marsh Instrument Co.	210
Gage, 344.5 bars (0 to 5000 lb/in ²) 10.2-cm (4-in) dial	Marsh Instrument Co.	210-35
Gage, 689 bars (0 to 10,000 lb/in ²) 10.2-cm (4-in) dial	Marsh Instrument Co.	210-35
Gage, 25.4-cm (0 to 15 lb/in ²) (1.1 10-in dial)	Futurecraft Corp.	90398
McLead gage	F. J. Stokes Corp.	176AC

- b. Hydraulics Laboratory. Table 5-16 lists the Hydraulics Laboratory equipment.

Table 5-16. Hydraulics Laboratory Equipment

Item	Manufacturer	Model No.
Hydraulic console	Sprague Engineering	--
Digital voltmeter	Hewlett-Packard	3440A
Digital voltmeter	Hewlett-Packard	405BR
Electronic counter	Hewlett-Packard	522B
AC power supply	NASA, KSC	--
DC power supply	Kepeco	PR 15-30

RELEASED

Table 5-16. Hydraulics Laboratory Equipment (Continued)

Item	Manufacturer	Model No.
Power resistor	Clarostat Mfg. Co.,	240-C
Vacuum pump	W. M. Welch Mfg. Co.	--
Digital voltmeter	Fluke	8300A
Electronic counter	Hewlett-Packard	5245L
Displacement leak meter	Aerometrics	1125730-9
Digital thermometer	Fluke	2100A
Swivel boom crane	Ruger	HP18CJ
Cast cutter	Stryker Corp.	840
Power control unit	Computer Accessories	P22

- c. Dissection Disassembly Laboratory. Table 5-17 list the Dissection Disassembly Laboratory equipment.

Table 5-17. Dissection Disassembly Laboratory Equipment

Item	Manufacturer	Model No
25.4 cm (10 in) lathe	Clausing	502104
30.5 cm (12 in) lathe	Monarch	EE
Vertical milling machine	Cincinnati	6J4V

RELEASED

K-STSM-14.1.14

Table 5-17. Dissection Disassembly Laboratory Equipment (Continued)

Item	Manufacturer	Model No
Radial arm drill press	Walker Turner	
45.4-metric ton (50-ton) hydraulic press	Macarco	50H
Grinder	Rockwell	8S
Bandsaw	Whitney	A24V
Dividing head	Harding	C597
Cutoff saw	Wells	V-229
Magnetic holding table	Ralmike	12
Rotary table	Palmgren	
Lapping plate	--	
Faceplate, 30.5 cm (12 in)	Monarch	
Faceplate, 15.2 cm (6 in)	Monarch	
Carbide tool grinder	Rockwell	8C
Dental pedestal grinder	--	
Internal vacuum system	--	
Shop air	N/A	N/A

RELEASED

5.4.2.5 Lubricants and Polymers Testing Laboratory. Table 5-18 lists the lubricants and Polymers Testing Laboratory equipment.

Table 5-18. Lubricants and Polymers Testing Laboratory Equipment

Item	Manufacturer	Model No.
Flash point tester (open and closed cups)	Various	Various
Viscosimeters		Brookfield, Saybolt, Cannon
4-ball wear tester	Precision Scientific	73603
Friction and wear tester	Dow-Corning	LFW-1
Grease working machine and penetrometer	Precision Scientific	--
Low temperature torque tester	Koehler Instruments Co., Inc.	K188
Functional-life ball bearing grease tester	Precision Scientific	73442
Water washout tester	Precision Scientific	73602
Grease dropping point tester	Precision Scientific	73455
Evaporation test cells	Precision Scientific	74905, 74929
Oxidation resistance test cells	Precision Scientific	73414
Melting point apparatus	Nagge	
Cloud and pour-point tester (for oils)	Precision Scientific	74521
pH meter	Beckman	Expandomatic

RELEASED

K-STSM-14.1.14

Table 5-18. Lubricants and Polymers Testing Laboratory Equipment (Continued)

Item	Manufacturer	Model No.
4-ball wear tester	Precision Scientific	--
Refrigerator (explosion-proof)	Lab-Line	Frigid Cab 13
Izod impact tester	Tinius-Olsen	--
Polymer heat distortion and vicat softening	Tinius-Olsen	--
High-pressure 4-ball tester	--	--
Grease working machine	--	--
Grease consistency tester	--	--
Gas permeability test cell	--	--
Polymer creep tester	Custom Scientific	--
Constant temperature baths	Various	Various
Plasticorder	Brabender	PLV 300
Melt index tester	Tinius-Olsen	--
Oven	Blue M	256E
Oven	Blue M	143A
Polymer torsion stiffness tester	Tinius-Olsen	--
Vapor degreaser	--	--
Ball mill	U.S. Stoneware	--
Temperature brittleness tester	Scott Tester	--

RELEASED

Table 5-18. Lubricants and Polymers Testing Laboratory Equipment (Continued)

Item	Manufacturer	Model No.
Balance	Mettler	H311
Oxygen index flammability tester	Custom Scientific	--
Heat sealer	Vertrod Corp.	--
Digital voltmeter	Hewlett Packard	4050R
Power supply	Trygon	M36-15A
Quartz dilatometer	--	--

5.4.2.6 Materials Testing Laboratory. Table 5-19 lists the Materials Testing Laboratory equipment.

Table 5-19. Materials Testing Laboratory Equipment

Item	Manufacturer	Model No.
Universal test machine	Instron	TTC
Universal testing machine	Tinius Olsen	--
Impact tester	Tinius Olsen	--
Hardness testers	Riehle-Wilson	--
Hardness tester	Shore Scleroscope	C-2
Low-power binocular microscope	Olympus	--

RELEASED

K-STSM-14.1.14

Table 5-19. Materials Testing Laboratory Equipment (Continued)

Item	Manufacturer	Model No.
Microscope	--	AO Microstar
Electrostatic charge test instrument	--	--
Electronic voltmeter	Hewlett-Packard	410C
Vacuum-tube voltmeters	Hewlett-Packard	400H and 410B
Insulation resistance bridge	--	--
Oscilloscope with plug-ins	--	--
Digital recorder	Hewlett-Packard	C13-562A
Function generators	--	--
Low-frequency oscillator	Hewlett-Packard	202CR
Electronic counter	Hewlett-Packard	5512A
Electronic counter	A TEC	6B86
2-channel strip-chart recorder	Hewlett-Packard	7100B
2-channel strip-chart recorder	Sanborn	297
Electronic milliohmeter	Hewlett-Packard	4328A
Muffle furnace	Lindberg	51442
Digital voltmeters	--	--
Regulated dc power supplies	--	--

RELEASED

Table 5-19. Materials Testing Laboratory Equipment (Continued)

Item	Manufacturer	Model No.
Portable wheatstone bridges	--	--
Hygrometer humidity indicator	--	--
General-purpose multimeters	--	--
Millivolt potentiometer	--	--
Electrometer	Keithley	610C
Integrating digital volt-meter	Hewlett-Packard	2401A
Clip-on dc milliammeter	Hewlett-Packard	428B
Oscillograph (visicorder)	Honeywell	1508
Low-impedance millivolt standard	Electronics Development Corp.	VS11R
Distortion analyzers	Hewlett-Packard	331A
Thermocouples and temperature controllers	--	--
Sample preparation	--	--
Milling machine	Bridgeport	JC12BRT
Lathe	Monarch	E
Bandsaw	Delta	28-364
Sander	Rockwell	
Drill press	Powermatic	1200

RELEASED

K-STSM-14.1.14

5.4.2.7 Metallurgical Laboratory. Table 5-20 lists the Metallurgical Laboratory equipment.

Table 5-20. Metallurgical Laboratory Equipment

Item	Manufacturer	Model No.
Bandsaw	Whitney	A24V
Microscope	American Optical Co.	D-5001
Stereomicroscope	Bausch & Lomb, Inc.	D2019
Microscope	American Optical Co.	624-009
Metallograph	Leitz Panphot	--
Metallograph	Vickers	55
Metallograph	Reichert Vacuothermat	--
Polisher	Buehler	64-1912AB
Polisher	Buehler	46-1511AB
Polisher	Buehler	47-1853AB
Polisher	Buehler	12-260-5V1
Etcher polisher	OSI	53C
Hardness tester	Wilson	5TT
Furnace control console	Lindberg	59344
Furnace muffle	Lindberg	51442
Furnace control console	Lindberg	59344
Crucible furnace	Lindberg	56622
Vacuum oven	Fisher	13-262-12V3

RELEASED

Table 5-20. Metallurgical Laboratory Equipment (Continued)

Item	Manufacturer	Model No.
Abrasive cutoff wheel	Buehler	45800
Etcher, electrolytic	Buehler	70-1740
Microscope	American Optical Co.	58M-D3
Macro camera	Lietz Aristophot	--
Microhardness tester	Tukon	--
Machine finish	Delta	31-520
Refrigerator	RFG	FD14TGL
Hardness tester	Ames	2
Clean air bench	Agnewhiggen	462
Stereomicroscope	Wild	M5

5.4.2.8 Metrology Laboratory. Table 5-21 lists the Metrology Laboratory equipment.

Table 5-21. Metrology Laboratory Equipment

Item	Manufacturer	Model No.
Validator	Brown & Sharp	--
Optical comparator	Jones and Lamson	EPIC 30
Surface analyzer	Brush	1121AALS
Borescope	National	A

RELEASED

K-STSM-14.1.14

Table 5-21. Metrology Laboratory Equipment (Continued)

Item	Manufacturer	Model No.
Vernier caliper	STA	123-36
Vernier gage	Lufkin	C-800A
Gage block	BRS	598-81-14
Optical ring	Steel City Testing Machines, Inc.	--
Gage blocks	STA	ARC81A1
Micrometer (3)	Mitutoyo	103217
Micrometer	STU	T12LNR
Micrometer depth gage (8)	Mitutoyo	--
Micrometer	STU	436-9
Sine plate	BRS	599925-10
Micrometer, light wave	Vankeuren	60-112
Micrometer	BRS	5996056
Micrometer	Lufkin	1944V
Micrometer (2)	STA	700
Micrometer (4)	BRS	30-1
Micrometer	STA	124-C
Micrometer	STU	T9
Micrometer	STA	436-11

RELEASED

Table 5-21. Metrology Laboratory Equipment (Continued)

Item	Manufacturer	Model No.
Micrometer set	MLF	41C307-10
Inside micrometer	STU	--
Vernier height gage	BRS	586
Micrometer	STA	4363
Vernier caliper 121.9 cm (48 in)	STA	122
Micrometer	STA	436-2
Micrometer	STA	436-5
Micrometer	Tubularm	--
Micrometer 22.9 to 25.4 cm (9 to 10 in)	Scherr-Tumico	--
Micrometer 20.3 to 22.9 cm (8 to 9 in)	Scherr-Tumico	--
Micrometer 15.2 to 22.9 cm (6 to 9 in)	Scherr-Tumico	--
Intri-micrometer	BRS	281
Balance, analytical	OHAVS	--
MKetal Lathe	Rivett	957-1203-6R
Shoe cleaner	Liberty	400A1
Micro toolkit	Jensen	MTK3

RELEASED

K-STSM-14.1.14

Table 5-21. Metrology Laboratory Equipment (Continued)

Item	Manufacturer	Model No.
Microscope	Olympus	XTR100
Borescope	--	G1
Inside micrometer	--	128
Hitacator	B&S	5851
Toolmaker's microscope	Unitron	TM-25

5.4.2.9 Metallographic Laboratory. Table 5-22 lists the Metallographic Processing and Preparation Laboratory equipment.

Table 5-22. Metallographic Processing and Preparation Laboratory Equipment.

Item	Manufacturer	Model No.
Metallographs/Microscopes:	Reichert Leitz Unitron LECO AO (Boom Stereo) Buehler Wild Bausch & Lomb (Boom Stereo) Unitron (Rollscope)	MeF2 624-009 Versamet 2 M300 85.31269Z - (Portable) M5 KTVB-73 15204
Hardness Testers:	Page-Wilson (tukon) Page-Wilson (Brinwell) Page-Wilson (Rockwell) Buehler (Micromet II) PROCEQ (Equotip) American Machines & Metals (Riehle)	M0728 J 500 1600-8000 ---- M-51

RELEASED

Table 5-22. Metallographic Processing and Preparation Laboratory Equipment. (Continued)

Item	Manufacturer	Model No.
Abrasive cutter	Buehler	10-1040-260
Low speed saw (2)	Buehler	11-1180-160
Auto polisher (2)	Buehler	69-1000-160
Polish-Etch machine	Buehler	70-3105
Electrolytic polisher (portable)	Buehler	70-1790
Mounting press (2)	Buehler	20-1320-115
Belt Surfacer	Buehler	16-1274
Slide printer and processing machine	Polaroid	3580/81-12
Muffle furnace	Lindberg	51442
Crucible furnace	Lindberg	56622
Furnance	National Appliance	13262/2V3
Environment chamber	Cincinnati Sub-Zero	UC522-2
Image analysis system	Cambridge	Q10
Charpy impact tester	Tinius-Olsen	E23
Sonic cleaner (2)	Sonicor	SC200TH
X-Ray illuminator	S&S X-Ray Products	187A
35mm camera	Nikon	F3

RELEASED

K-STSM-14.1.14

5.4.2.10 Coatings Evaluation Laboratory. Table 5-23 lists the Coatings Evaluation Laboratory equipment.

Table 5-23. Coatings Evaluation Laboratory Equipment

Item	Manufacturer	Model No.
Paint spray booth	--	--
Abrasive blast cabinet	Kelco	CH-30A
Fluidized bed coating equipment	--	--
Paint shakers	--	--
Mixers, air-driven	--	--
Pressure pots	--	--
Spray guns	--	--
Abrasion resistance tester	--	--
Thickness gages, 0 to 30 mils	Mikrotest	--
Thickness gages, 100 to 400 mils	Mikrotest	--
Permascope, 0 to 10 mils	--	--
Balance beam	Bell Telephone Laboratories	--

5.4.2.11 Liquid Oxygen Testing Laboratory. Table 5-24 lists the Liquid Oxygen Testing Laboratory equipment.

RELEASED

Table 5-24. Liquid Oxygen Testing Laboratory Equipment

Item	Manufacturer	Model No.
LOX impact tester	--	--
Punch press	NAFF	B
Dies	--	-
Cryogenic dewars	Supairco	--
Drying oven	FORMA-VAC	3237
Vapor degreaser	Bransen	TVD-60
Oxygen aging chamber	-	--

5.4.2.12 MMAL Installed Utilities. The utilities available in the MMALS are listed in table 5-25.

Table 5-25. MMAL Installed Utilities

Laboratory	Utilities
Electrical Power Laboratory Room 2275	<ul style="list-style-type: none"> o Standard 120-V ac and 208-V ac power o 480-V ac, 3-ϕ power o Hot and cold water (sink) o 206.7-bars (3,000-lb/in gage) GN2 with outside vent o 413.4-bars (6,000-lb/in gage) GHe with outside vent o Filtered shop air, 8.6 bars (125 lb/in) o Raised floor
Electronics Lab Room 2271, 2271A, 2271B	<ul style="list-style-type: none"> o Raised floor o Air-conditioning system for rack cooling o Standard 120-Vac and 208-Vac power o Hot and cold water (sink) o 110-V ac critical instrumentation power
Environmental Testing Laboratory Rooms 1213A&B & 1219	<ul style="list-style-type: none"> o Standard 120-Vac and 208-Vac power o Shop air o Water

RELEASED

K-STSM-14.1.14

Table 5-25. MMAL Installed Utilities (Continued)

Laboratory	Utilities
Fluid Mechanical Lab	<ul style="list-style-type: none"> o 3206.7-bars, (3000-lb/in² gage) GN2 with outside vent o 413.4-bars (6,000-lb/in² gage) GHe with outside vent o AC power supply, 400 Hz, 120/208 variable voltage o 480-V ac, 3-Ø, 3- and 4-wire power o Shop air o Water and drains o Standard 120-Vac and 208-Vac power o Vacuum system
Lubricants & Polymers Testing Lab Room 2221	<ul style="list-style-type: none"> o Standard 120-Vac and 208-Vac power o Shop air
Materials Testing Lab, Room 1219	<ul style="list-style-type: none"> o Standard 120-Vac and 208-Vac power o Vacuum system o Shop air
Metallurgical Lab Rooms 2217, 2217A	<ul style="list-style-type: none"> o Numerous hot and cold water outlets with drains and special traps o Chemical fume hood and vent system o Water chiller and recirculator system o Special lighting system for infrared photography o Standard 120-Vac and 208-Vac power o Shop air
Metrology Lab Room 2275	<ul style="list-style-type: none"> o Standard 120-Vac and 208-Vac power o Vent hood o Raised floor
Plastics and Polymers Processing Lab Room 1213	<ul style="list-style-type: none"> o Standard 120-Vac and 208-Vac power o Chemical fume hood and vent system o Hot and cold water (sink)

5.4.3 MCAL. The MCAL locations and space are listed in table 5-26.

RELEASED

Table 5-26. MCAL Locations and Space

Room Number	Use Description	Space	
		m ²	(ft ²)
1268	Infrared spectrometer	60.4	(650)
1269	Gas chromatograph-mass spectrometer	60.2	(648)
1269A	Emission spectrograph	33.4	(360)
1269B	Electron microprobe	22.3	(240)
1269C	Scanning electron microscope	16.9	(182)
1269D	Darkroom	12.1	(130)
1269E	Wet chemistry	58.1	(625)
1269F	Gas chromatograph-mass spectrometer data	16.7	(180)
1270	X-ray analysis	23.7	(255)
1270A	Thermal analysis	17.4	(187)
1270B	Electron spectrometer	17.5	(188)
1274	Office	18.6	(200)
1274A	Laboratory computation	6.6	(71)
1274B	X-ray data	13.5	(145)
1274C	Instrument repair	11.2	(120)
1274D	MCAL office	7.9	(85)
1296	Chromatographic analysis	49.8	(536)
1296A	Chromatographic analysis	13.4	(144)
1296B	Reagent storage	13.4	(144)
2283	Quantitative gas analysis	46.5	(500)

RELEASED

K-STSM-14.1.14

5.4.3.1 MCAL Equipment. The equipment available in the MCALs is presented in table 5-27.

Table 5-27. MCAL Equipment

Item	Manufacturer	Model No.
Analyzer, sulfur and high-low carbon	Leco	
Analyzer, carbon, hydrogen and nitrogen	Hewlett-Packard	185R
Analyzer, gas infrared	Lira	300 ND IR
Asher, low temperature	International Plasma Corp.	2040C
Analyzer, electron microprobe	JOEL	733
Analyzer, controlled potential	Fisher	--
Analyzer, carbon	Leco	515000
Analyzer, chromatograph infrared	Cira	101
Analyzer, thermal	Mettler	--
Balance, analytical	Mettler	H16
Balance, micro	Mettler	M5
Balance	Mettler	K7/T
Balance, analytical	Mettler	B6
Balance, analytical	Mettler	H15
Balance	Mettler	800G
Calculator	DEC	PDP-11/40

RELEASED

Table 5-27. MCAL Equipment (Continued)

Item	Manufacturer	Model No.
Calculator	Olivetti	P101US
Calorimeter, oxygen bomb	Parr Instrument Co.	1221
Calorimeter, differential scanning	Perkin-Elmer	DSC-1B
Chromatograph, liquid	Hewlett-Packard	108413
Chromatograph, gas	Hewlett-Packard	5756B
Chromatograph, ion	Dionex	2120
Clean station	Ramney	FC4302
Clean station	Ramney	FC6302
Comparator	Gaertner	
Computer	PDP	11/40
Densitometer, recording	Jarrell-Ash	
Detector, N ₂ H ₄	MDA Scientific, Inc.	7080
Detector, N ₂ O	MDA Scientific, Inc.	7030
Drybox	Temperature Engineering	4124
Leak detector	CED	24-120A
Meter, radiation survey	Victoreen Instrument Co.	Thyac III 490
Meter, pH	Beckman	GS
Meter, pH	Beckman	96
Microscope	Bausch & Lomb, Inc.	BVB 73

RELEASED

K-STSM-14.1.14

Table 5-27. MCAL Equipment (Continued)

Item	Manufacturer	Model No.
Microscope, optical binocular	Bausch & Lomb, Inc.	BV 105
Microscope, electron transmission	Hitachi	HU11A
Microscope	Bausch & Lomb, Inc.	SKVB 73
Microscope	Bausch & Lomb, Inc.	L2300TCTR
Microscope, electron scanning	Cambridge	96113-2A
Microscope	Bausch & Lomb, Inc.	BV 1070X
Oscilloscope	Tektronix	555
Ovens, ashing	--	--
Plate reader	Projectina	21-088
Polarograph	Sargent	XV
Press, hydraulic	Loomis	341-20
Microtome	LKB	8800A
Microtome knifemaker	LKB	7801A
Oscillator	Hewlett-Packard	200 CD
Refractometer, ABBE	Bausch & Lomb, Inc.	36
Refrigerator	Raetone	AR40-S
Spectrophotometer	Perkin-Elmer	127-1271
Spectrophotometer	Perkin-Elmer	303
Spectrophotometer	Aminco	4-8202

RELEASED

Table 5-27. MCAL Equipment (Continued)

Item	Manufacturer	Model No.
Spectrophotometer	Perkin-Elmer	621
Spectrophotofluorometer	Aminco	4-8202
Spectrometer	Bausch & Lomb, Inc.	X866
Spectrometer	Varian	VIEE-15
Spectrograph	Jarrell-Ash	19-300
Spectrometer, fourier transform	DIGILAB	FTS-20
Spectrometer, fourier transform	NICOLET	7199
Spectrometer, mass	CEC	104
Spectrometer, mass	DuPont	21-492
Spectrophotometer	Bausch & Lomb, Inc.	DK2A
Spectrophotometer, infrared	Perkin-Elmer	283
Spectrophotometer	Block	FTS 20
Typewriter	IBM	715
Ultrasonic cleaner	Ultrasonic Industries, Inc.	G-250A1
Vacuum evaporator	Seevac	Conductavac II
Vacuum evaporator	Kinney	KSE2
Vacuum pump station	Veeco	VS-9

RELEASED

K-STSM-14.1.14

Table 5-27. MCAL Equipment (Continued)

Item	Manufacturer	Model No.
Voltmeter	Hewlett-Packard	3440A
X-ray spectrograph	Philips	XRG 500
X-ray generator	Philips	12010100
X-ray generator	Philips	88978

5.4.3.2 MCAL Utilities. The MCALs have standard 120-V ac and 208-V ac power, a chemical fume hood and vent system, and hot and cold water taps with drains and special traps.

5.5 SPECIAL PURPOSE AREAS

5.5.1 ROOM 1255 AND 1259. Rooms 1255-1555 and 1259-1559 containing 134.7-m² (450 ft²) are used for the electrical support shop, the Test and Inspection Record (TAIR) Center, and Instrument Pointing System (IPS) laboratory. Entry is obtained through the bay area and aisle.

5.5.2 KSC INSTRUMENT CALIBRATION LABORATORY. Rooms 2289 and 2291 contain the KSC Instrument Calibration Lab and the Staging and Loan Pool for instruments. Payload instruments may be calibrated there, and instruments for payload support may be borrowed from the pool. Payload owners should request this support through the LSSM.

5.5.3 EXPERIMENT INTEGRATION ELECTRICAL SHOP. Room 1493 on the southwest end of the bay area is the electrical-electronics shop for experiment integration support. Cable fabrication in support of experiment integration activities is performed in 1493. The shop contains 120-V, 60-Hz, 1-Ø ac power receptacles, compressed air, and facility water. Figure 5-13 shows the general layout of room 1493. Requests for this support should be made through the LSSM.

5.5.4 ASTRONAUT BREATHING AIR SYSTEM (Room 3287). The astronaut breathing air system is supplied by 24 k-bottles located in the O&C cul-de-sac. A stainless steel tube is routed from the k-bottles up the north wall of the laboratory, control and monitor area providing 100 psi breathing air to room 3287. The 100 psi is fed to a master panel which supplies 8 interface panels. Each interface has a 3 psi and 100 psi outlet panel and is used to perform cooling and leak checks on the astronaut's partial pressure flight suits.

RELEASED

K-STSM-14.1.14

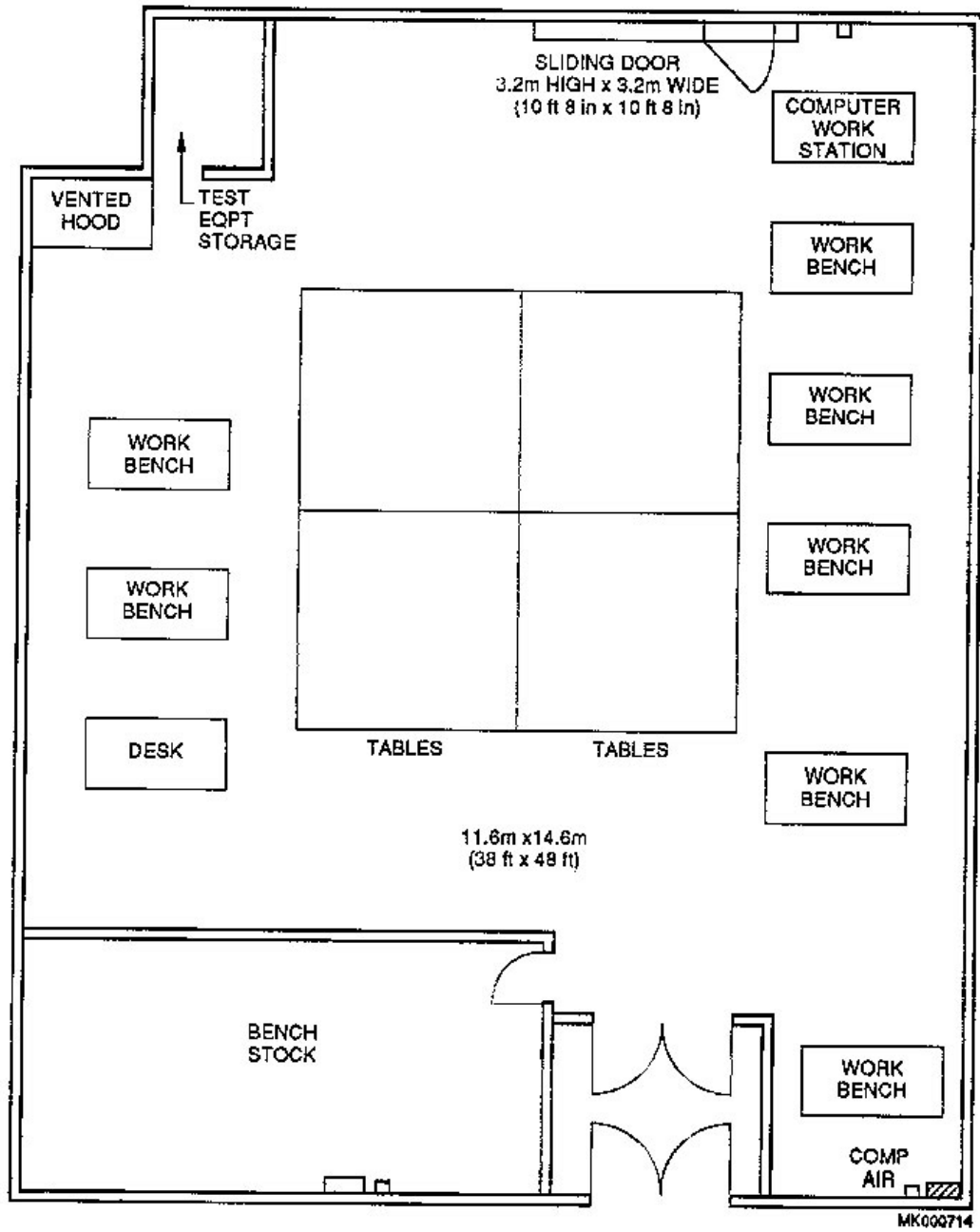

Figure 5-12. Room 1493, Electrical Shop

RELEASED

K-STSM-14.1.14

THIS PAGE INTENTIONALLY LEFT BLANK

RELEASED

SECTION VI

STORAGE AND OTHER AREAS

6.1 GENERAL DESCRIPTION

The remaining payload-related areas in the O&C Building are summarized in table 6-1. Floor space is provided for some of the rooms that may be used for off-line payload or GSE work. All areas described receive the standard O&C Building environmental control as shown in table 3-1.

6.2 RECEIVING AND INSPECTION

Room 1469 is used for receiving and inspection of the payload flight equipment and GSE at KSC. The room is equipped with two 4.6-m (15-ft) high by 6.1-m (20-ft) wide sliding doors, one leading to the outside of the building on the south side and one into the bay area on the north. One personnel door 0.8 m (2 ft 8-1/2 in) wide by 2.1 m (6 ft 11 in) high is located to the left of the north sliding door. A 3.6-metric ton (4-ton) electric monorail hoist is provided in room 1469 which provides service through the center of the entire length of the room and to the outside door. Ceiling height is 4.5 m (15 ft); hook height is 3.6 m (12 ft). Figure 6-1 shows room 1469 and the path of the monorail hoist. The hoist hook details are provided in 79K16211. Room 1469 has the following ac power explosion-proof receptacles located on the south, west, and north walls:

- a. 120/208 V, 60-Hz, 20-A and 30-A, 1- \emptyset and 3- \emptyset
- b. 250-V to 600-V, 100-A, 3- \emptyset
- c. 480-V, 60-Hz, 30-A and 60-A, 1- \emptyset

There is compressed air at 9 bars (125 lb/in²) located on each of the three walls with electrical power.

6.3 SECOND FLOOR AREAS

Rooms 2287 through 2291 are used for the instrument loan pool and instrument calibration lab. Instruments from the pool can be loaned for payload support. Requests should be made through the Experiment Project Engineer.

6.4 THIRD FLOOR AREAS

Room 3263 contains the Lyndon B. Johnson Space Center (JSC) Flight Data File, room 3289 contains the astronaut suit room, rooms 3291 and 3293 contain the astronaut pre/post physical examination room, and room 3299 contains the Flight Crew Equipment (FCE) labs. These are controlled access areas.

RELEASED

K-STSM-14.1.14

Table 6-1. Storage and Other Areas

Room Number	Use Description	Floor Space m ² ft ²
First Floor		
1253	Bay area locker room	96.7 (1041)
1445 1449 1451 1457	Staging and assembly areas (see Section III)	
1469	Receiving and inspection	209.0 (2250)
1493	Experiment Integration Electrical Shop	
Second Floor		
2287 -2291	Instrument loan pool	N/A
Third Floor		
3263	JSC flight data file	N/A
3289	Astronaut suit room	N/A
3291 & 3293	Astronaut pre/post physical examination room	N/A
3299	Flight crew equipment labs	N/A
Fourth Floor		
4227 - 4231	Tape certification rooms	278.7 (3000)
4247	OTV control room	N/A
4266 - 4268	Voice System Control Room (Heated repair and dispensary)	N/A
4269	Payload Customer Management Center (CMC)	
Lobby area	Locked storage	40.8 (134)

RELEASED

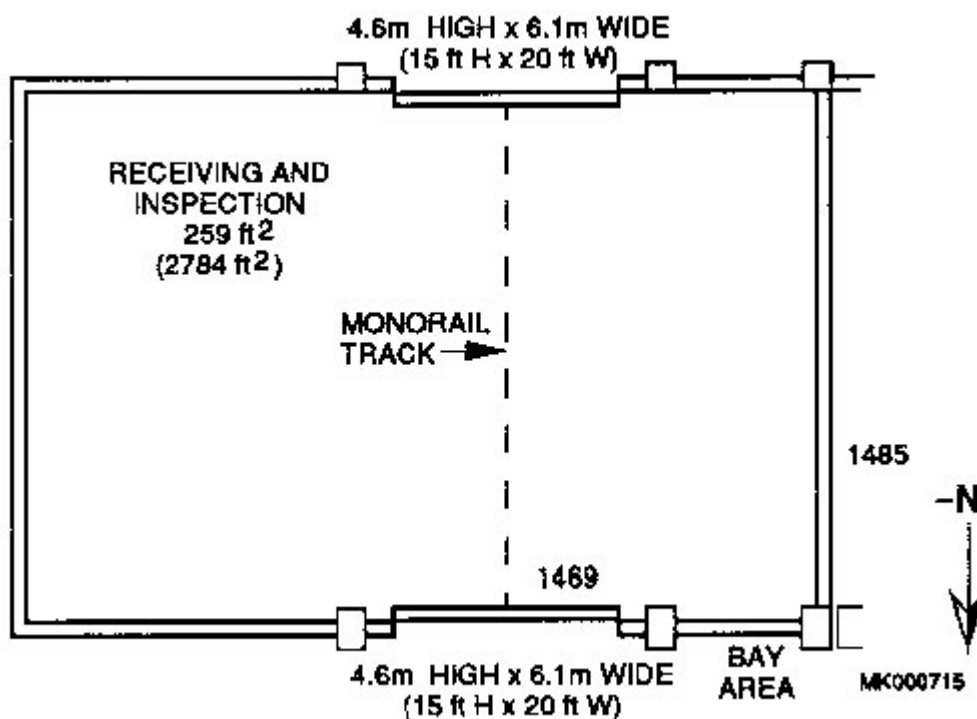

Figure 6-1. Receiving and Inspection

6.5 FOURTH FLOOR AREAS

The fourth floor contains the user rooms, as described in section IV, rooms for tape certification (rooms 4227 and 4231), headset dispensary and repair. In addition, there is an area of locked storage in the lobby of the fourth floor. Rooms 4266 and 4268 contain headset dispensary and repair. Headsets should be requested through the Experiment Project Engineer.

RELEASED

K-STSM-14.1.14

THIS PAGE INTENTIONALLY LEFT BLANK

RELEASED

**APPENDIX A
GLOSSARY**

RELEASED

K-STSM-14.1.14

THIS PAGE INTENTIONALLY LEFT BLANK

RELEASED

GLOSSARY

These definitions are taken from K-SLM-14, *Horizontal Payloads Accommodations Handbook for STS Payloads* and *NASA Reference Publication 1059 Revised*.

- a. Automatic Test Equipment (ATE) = Computer-controlled test equipment supplied by the European Space Agency (ESA) and used for Spacelab-payload integration in the O&C Building. ATE procedures are prepared in GOAL (Ground Operations Aerospace Language). The Launch Processing System (LPS) uses GOAL.
- b. Experiment = The system of hardware, software, and procedures for performance of a scientific or applications undertaking to:
 - (1) Discover unknown phenomena
 - (2) Establish the basis of known laws
 - (3) Evaluate applications processes and equipment
- c. Experiment Project Engineer = Technical point of contact with the payload operations organization.
- d. Flight Crew Equipment (FCE) = Sometimes called Flight Crew Systems (FCS) equipment, includes all equipment stowed, worn, or carried into the orbiter or Spacelab module and used by the flight crew during flight or ground operations, plus all packing material and storage provisions for these items. KSC develops the stowage list for the Spacelab. JSC has overall responsibility for overall control of STS element storage.
- e. Ground Support Equipment (GSE) = Non-flight equipment, implements, and devices required for handling, servicing, inspecting, testing, maintenance, alignment, adjustment, checking, repairing, and overhauling of an operational end item, a subsystem, or component - usually flight hardware.
- f. Launch Site Support Manager = Individual at the launch site center who is the single point of contact with users or customers in arranging payload processing at the launch site.
- g. Off-Line = Activities conducted by the payload independent of any Space Shuttle element (orbiter, ET, SRBs, as well as Spacelab). Normally, such activities are conducted in a facility separate from Space Shuttle processing; e.g., Hangar L for Life Sciences off-line activities or off-line laboratories.
- h. On-Line = Activities conducted with a payload and one or more Space Shuttle elements. On-line activities are controlled by KSC work control and scheduling system.
- i. Payload = Total complement of specific instruments, space equipment, support hardware, and consumables carried in the orbiter (but not included as part of the basic orbiter payload support) to accomplish a discrete activity in space.

RELEASED

K-STSM-14.1.14

- j. Spacelab = General-purpose lab for manned and automated activities in near-Earth orbit.
 - (1) Module - Pressurized manned lab portion
 - (2) Core segment - Section of the pressurized Spacelab module that houses subsystem equipment and experiments
 - (3) Rack - Removable and reusable Spacelab assemblies that provide mounting and power, data, and thermal connections for payload equipment housed in the module
 - (4) Pallet - External unpressurized platform for mounting equipment requiring direct exposure to space
 - (5) Pallet train - More than one pallet rigidly connected to form a single unit
 - (6) Igloo - Pressurized container for Spacelab pallet subsystems when no module is used
- k. Support equipment = Those items that are not an integral part of an end item (or flight hardware) but are required in the operation of the end item.

RELEASED

**APPENDIX B
REFERENCES**

RELEASED

K-STSM-14.1.14

THIS PAGE INTENTIONALLY LEFT BLANK

RELEASED

B-2

REFERENCES

GP-1032	Materials Analysis Branch Capability Manual, Rev. 2 (11/83)
ICD-2-5A001	Spacelab Program ICD, KSC Facility to Spacelab GSE (Mechanical)
ICD-2-5A002	Spacelab Program ICD, KSC Facility to Spacelab GSE (Electrical)
K-CITEM-10.1.7	Cargo Integration Test Equipment (CITE) Requirements Document (1/27/78)
K-SLM-14	Horizontal Payloads Accommodations Manual (2/15/79)
K-STSM-14.1	Launch Site Accommodations Handbook for STS Payloads, Rev. B (1/83)
K-STSM-14.1.9.1	LSFE Facility Users' Guide
K-STSM-14.2.1	KSC Cargo Facility Contamination Control Plan (12/83)
KCI-HB-5340.1	Cargo Facility Contamination Control Implementation Plan (12/83)
KCS-HB-0003.0	Cargo Integration User Handbook (8/80)
KCS-PL-0004.0	Experiment Integration Plan Spacelab Mission One (8/81)
KSC-DD-111	Facility Access and Hoisting Provisions for Payloads at Kennedy Space Center (7/80)
KSC-LPS-OP-033-13	CITE User's Guide
KSC-PL-0004.0	SL-1 Experiment Integration Plan (8/80)
KSC-PL-0006.0	SL-2 Experiment Integration Plan
MDC Y0303	Description of Environmental Monitoring System in the Operations Checkout Building (1/86)
MJ072 0012-1	PITS End-Item Specification
TM4-254 Vol. XI	Unified S-Band Site KSC Halon 1301, Fire Alarm Detection and Suppression Systems, Operations and Maintenance
SD 78-SH-0257	Payload Integration Test Set User's Manual
SLP/2104	Spacelab Payload Accommodations Handbook
79K01998	ATM Clean Room

RELEASED

K-STSM-14.1.14

79K04242	O&C Television Data Display System
79K07913	O&C Building Spacelab Modifications
79K16211	Horizontal Processing Facility Standard Interface Document (12/84)
79K17089	O&C Building Spacelab Modifications, Level IV Integration
- - -	KSC Life Sciences Flight Experiments Operations Plan

RELEASED

478A K-STSM-14.01.14

FACILITIES HANDBOOK FOR O&C BUILDING PAYLOAD PROCESSING
AND
SUPPORT CAPABILITIES (ELECTRONIC LIST) 12/01/94

CG-LSO	W. FLETCHER
CG-LSO	K. MEASE
CM-INT-3	J. STRAITON
CM-PMO	C. EZMAN
CS	M. CARDONE
CS-EXD	J. LACKOVICH
CS-OTE	R. BOURNE
CS-OTE-2	M. RODRIGUEZ
CS-PED	S. BARTELL
CS-PTS	D. WEBB
CS-PTS-21	H. RICE
CV-LOD-2	C. MCEACHERN
MDSS-KSC-F200	J. SCHOFIELD
MDSS-KSC-F208	M. HUTCHINS
MDSS-KSC-F470	M. ATKINSON
MDSS-KSC-F620	D. CROOKER
MDSS-KSC-F626	P. SECCURO
MDSS-KSC-F672	J. PASTER

TOTAL 18

For distribution changes contact your Validation Representative:

KSC/CM--P. Davis:[**CM-LMD-2,7-7755**]

KSC/DE/DF/DL--B. Judd:[**DF-ESD,7-4112**]

KSC/RQ--D. Coleman:[**RQ-ADM,7-3577**]

KSC/IM--H. Brown:[**IM-SAT-5,7-4540**]

KSC/TM--K. Biega:[**TM-ADM,7-3898**]

ALL OTHERS [**PAYLOAD**]-P. Davis, **CG-LMD-2, (407)867-7755**

ALL OTHERS [**SHUTTLE**]-K. Biega, **TM-ADM, (407)867-3898**

SYSTEM PROBLEMS/PERFORMANCE--KSC Documents Library, **LIBRARY-D, 7-9601/3613**

ELECTRONIC DISTRIBUTION

RELEASED

478B K-STSM-14.01.14 FACILITIES HANDBOOK FOR O&C BUILDING PAYLOAD PROCESSING AND
SUPPORT CAPABILITIES (NON-ELECTRONIC LIST) 12/01/94

5 SPW/SESE	W. BREYER	
AC-PRO	N. TALLUTO	
BOC-323	S. MCGOVERN	
CG	R. HEUSER	
CG-GSD-1		3
CG-LSO-1	D. BRUSE	
CG-LSO-2	LIBRARY	25
CM-INT-1	P. BOGLE	
CS-EXD-3	C. MCPHILLIPS	
CS-IOD-2		
CS-PED-2	M. MATIS	
CS-PTS-13	M. SMITH	
CV-LOD	D. BRAGDON	
CV-LOD	F. CURINGTON	
CV-PSO	A. MACKEY	
DE-FLS	R. EVANS	
DE-PMO-3	H. HILTON	
DE-PMO-3	W. STAMPLEY	
DE-PMO-5	H. PEETE	
DF-ESD-2	B. NELSON	
DF-ESD-2A	W. GLUSING	
ORMS WAREHOUSE		30
M-PSO	G. WISTRAND	
PL-AO		2
IBRARY-D	KSC LIB DOCS	2
SO-038	LIBRARY	
MDAC-HSV	W. TURNER	
MDSS-CX-17	D. MACLEAN	
MDSS-KSC-F154	D. TAGUE	
MDSS-KSC-F364	LIBRARY	
MDSS-KSC-F366	LIBRARY	10
MDSS-KSC-F658	TDC LIBRARY	
MDSS-KSC-F814	R. KURRUS	2
MMC-AF	E. O'CONNOR	
RO-PAY	C. ZIMMERMAN	
RT-SAF-2	R. WOODS	
RT-SOE-1	J. DOLLBERG	
RT-SOE-2	J. TINSLEY	
M-LLP	R. THARPE	
V-PEO-1	LIBRARY	
ERC-60-3	A. LILLY	
SPACEHAB		
ATTN: W. SPRADLIN		
620 MAGELLAN RD.		
CAPE CANAVERAL, FL 32920		

TOTAL 110

HARD COPY DISTRIBUTION

or distribution changes contact your Validation Representative:

KSC/CM--P. Davis:[CM-LMD-2,7-7755]

KSC/DE/DF/DL--B. Judd:[DF-ESD,7-4112]

KSC/RQ--D. Coleman:[RQ-ADM,7-3577]

KSC/IM--H. Brown:[IM-SAT-5,7-4540]

KSC/TM--K. Biega:[TM-ADM,7-3898]

ALL OTHERS [PAYLOAD]--P. Davis, CG-LMD-2, (407)867-7755

ALL OTHERS [SHUTTLE]--K. Biega, TM-ADM, (407)867-3898

SYSTEM PROBLEMS/PERFORMANCE--KSC Documents Library LIBRARY-D, 7-36(1) 3613

RELEASED