

NASW-3921

Tethers in Space Handbook

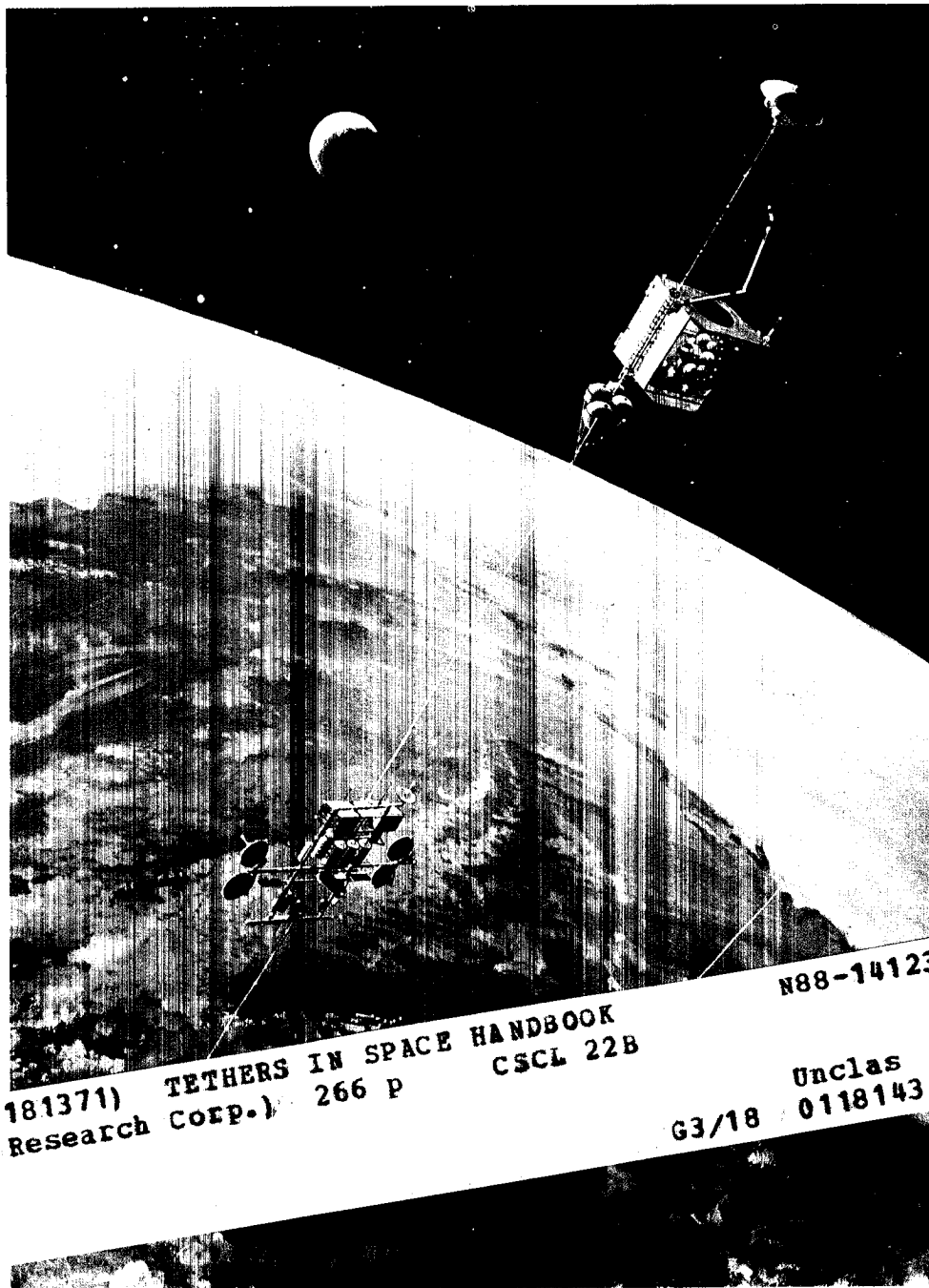

(NASA-CR-181371) TETHERS IN SPACE HANDBOOK
 (General Research COEP.) 266 P CSCL 22B

N88-14123

G3/18 Unclass 0118143

AP
 19
 USGA

National Aeronautics and Space Administration
 Office of Space Flight
 Advanced Programs
 NASA Headquarters
 Code MT
 Washington, D.C. 20546

This document is the product of support from many organizations and individuals. General Research Corporation, under contract to NASA Headquarters, compiled and prepared the final document.

Sponsored by: National Aeronautics and Space Administration
NASA Headquarters
Code MT
Washington, DC 20546

Contract Monitor: Edward Brazill

Task Monitor: Paul Penzo

Contract Number and Title: NASW—3921
Planning and Analysis of Advanced Programs

Contractor: General Research Corporation
Space Systems Operations (McLean)
7655 Old Springhouse Road
McLean, VA 22102

Project Manager: T. G. Reese

Handbook Coauthors: W. A. Baracat, C. L. Butner

Cover picture courtesy of Robert McCall. Copyright © 1986 by Bantam Books, Inc. Reprinted by permission of Bantam Books, Inc. All rights reserved.

**Tether
Programs**

Tethers in Space Handbook

**Tether
Fundamentals**

August 1986

Applications

Appendix

Prepared For:

**National Aeronautics and Space Administration
Office of Space Flight
Advanced Programs**

**References and
Selected
Bibliography**

NASA
National Aeronautics and
Space Administration

Contacts

FOREWORD

The Tethers in Space Handbook is designed to serve as a reference manual for policy makers, program managers, and engineers alike. It documents all known tether applications for space uses, ranging from near-term approved missions such as the Tethered Satellite System to far-term planetary exploration missions. A brief summary of each application is presented, as well as a listing of principal investigators and references for further reading. The Tethers in Space Handbook also provides descriptions of all currently planned or approved tether missions, on-going tether studies, and a short tutorial on the mechanics of tether behavior. Applications and ideas presented in this handbook have been gleaned from a variety of sources, including workshops, contractor studies, and NASA documentation. The international community, especially the Italian researchers, have contributed substantially to the body of the applications.

It is the hope of NASA and General Research Corporation that this handbook will serve not only to document presently planned tether applications, but also as a creative base from which new and improved applications may be derived. As man obtains a greater presence in space, many of the tether applications that appear in this handbook will become reality, enhancing the exploration and utilization of the near-Earth environment and beyond.

PRECEDING PAGE BLANK NOT FILMED

PRECEDING PAGE BLANK NOT FILMED

INTRODUCTION

It is the intent of this handbook to provide the reader with an overall summary of proposed potential applications of tethers in space, a reasonably detailed description of each one, and a description of the physical principles fundamental to them. To accomplish this most effectively, the handbook has been divided into sections, which address each of these aspects of tethers. Reference numbers appear throughout each section of the handbook to indicate source material for further reading. Complete listings for this source material can be found in the "References and Selected Bibliography" section of the handbook.

Section 1 of the handbook provides a list and description of ongoing tether programs. This includes the joint U.S.-Italy demonstration project (the Tethered Satellite System - TSS), and individual U.S. and Italian studies and demonstration programs. This section will provide the reader with an overview of the current activity level and areas of emphasis in this emerging field.

Section 2 addresses the fundamental physical principles behind proposed tether applications. This discussion is divided among the four basic concepts of gravity gradient, rotation, momentum exchange, and electrodynamics. This was thought to be the most logical way to categorize the appropriate physical fundamentals, providing basic conceptual units which can be combined as required to analyze the physical mechanisms involved with each application. All of the tether applications envisioned up to this point utilize one or more of these concepts.

Section 3 provides a detailed summary of each tether application proposed up to this printing. In some cases, these applications are nothing more than general ideas, and in others, they are well-defined systems, based on detailed study and computational analysis. These applications have been divided into eight general categories. In cases where an application can be logically placed in more than one, it has been placed in the one considered most appropriate. In cases where an application, or its basic system concept, can be manifested in more than

PRECEDING PAGE BLANK NOT FILMED

PAGE IV INTENTIONALLY BLANK

v

PRECEDING PAGE BLANK NOT FILMED

ORIGINAL PAGE IS
OF POOR QUALITY

one configuration, each involving a significantly different design feature or size, these variations may be placed in different categories, as appropriate. To avoid redundancy, every possible variation of a particular system concept is not described separately. Instead, Section 3 begins with a table, cross-referencing each application and the categories with which it has a logical existing or potential connection. This table is intended to help the reader identify potential areas of use, which extend past the single category in which each application description appears. It should also give the reader an appreciation of the potential scope and usefulness of each application and its basic system concept. Descriptions of proposed applications follow this cross-reference. For these descriptions, a standardized format is used to allow quick and easy comparisons of different applications. This format is designed to convey the pertinent details of each application. Readers with different interests and needs can find the information and level of detail they desire at a glance. Section 3.1 offers a detailed description of the format used in each application description.

Section 4, the Appendix, presents information extracted from existing literature, which supplements and enhances the information presented in Sections 2 and 3 ("Fundamentals" and "Applications"). This supplementary information was selected to increase the depth and scope of these earlier sections, and to provide the reader with a further indication of the type and level of work which has been done.

Section 5, "References and Selected Bibliography," contains a list of references which were used in the preparation of this document. This section also contains an extensive bibliography containing documents concerning tether applications in space. This selected bibliography is divided into 10 subsections by categories of major emphasis.

Finally, Section 6 ("Contacts") lists the addresses and phone numbers of principal investigators listed in the application descriptions. This list also includes other investigators presently conducting research with tether applications in space.

It is clear that, in the quickly evolving field of tether applications in space, the information available for the applications presently listed in this handbook will increase. New applications and concepts will also be generated. It is anticipated that future revisions of this handbook will appear to accommodate these changes. Any editorial comments, technical corrections, or new applications would be welcome by the authors of this handbook. It is the intent of NASA and the General Research Corporation to provide the most current information available in this exciting field of tether applications in space.

TETHERS IN SPACE HANDBOOK
TABLE OF CONTENTS

	Page
Foreword	iii
Introduction	v
1 TETHER PROGRAMS	1-1
1.1 Tethered Satellite System	1-3
1.2 Proposed Tether Experiments	1-9
1.2.1 Small Expendable Deployer System	1-9
1.2.2 Plasma Motor Generator	1-10
1.2.3 Kinetic Isolation Tether Experiment	1-11
1.3 United States Tether Studies	1-13
1.4 Italian Tether Studies	1-19
1.4.1 Science and Applications Tethered Platform Advanced Studies	1-19
1.4.1.1 Tethered Space Elevator Study	1-20
1.4.1.2 Tethered Pointing Platform Study	1-21
1.4.1.3 Complex Tether Technology Study	1-22
1.4.2 University of Padova Tether Studies	1-23
1.4.2.1 Dynamics of TSS	1-24
1.4.2.2 Future Applications of Tethers in Space	1-24
2 TETHER FUNDAMENTALS	2-1
2.1 Gravity Gradient	2-3
2.1.1 General	2-3
2.1.2 Controlled Gravity	2-10
2.1.3 Constellations	2-14
2.2 Rotation of Tether Systems	2-22
2.2.1 General	2-22
2.2.2 Controlled Gravity	2-22
2.3 Momentum Exchange	2-24
2.3.1 General - Conservation of Angular Momentum	2-24
2.3.2 Tether Payload Deployment	2-25
2.3.3 Orbit Variations	2-27
2.4 Electrodynamics	2-29
2.4.1 General	2-29
2.4.2 Electric Power Generators	2-29
2.4.3 Thrusters	2-37
2.4.4 ULF/ELF/VLF Antennas	2-42
2.4.5 Constellations	2-45

TETHERS IN SPACE HANDBOOK
TABLE OF CONTENTS (CONT.)

		Page
3	APPLICATIONS	3-1
	3.1 General	3-3
	3.2 Critical Issues	3-4
	3.3 Tether Applications Index and Cross Reference	3-7
	3.4 Tether Applications	3-17
4	APPENDIX	4-1
5	REFERENCES AND SELECTED BIBLIOGRAPHY	5-1
	5.1 References	5-3
	5.2 Selected Bibliography	5-9
	5.2.1 General	5-11
	5.2.2 Tethered Satellite System	5-14
	5.2.3 Science Applications	5-19
	5.2.4 Electrodynamics	5-21
	5.2.5 Transportation	5-24
	5.2.6 Controlled Gravity	5-27
	5.2.7 Constellations	5-28
	5.2.8 Technology and Test	5-29
	5.2.8.1 General	5-29
	5.2.8.2 Dynamics and Control	5-30
	5.2.8.3 Materials Technology	5-33
	5.2.9 Space Station	5-35
	5.2.10 Planetary	5-36
6	CONTACTS	6-1

SECTION 1
TETHER PROGRAMS

1.1 TETHERED SATELLITE SYSTEM

The Tethered Satellite System (TSS) is a joint undertaking between the United States and Italy. Presently, only the first mission, TSS-1, is approved with planning authorized for TSS-2 and TSS-3. The system consists of a U.S.-built deployer and an Italian-built satellite, both of which are reusable. The prime contractors for the TSS deployer and satellite are Martin Marietta Denver Aerospace and Aeritalia, respectively. The satellite is deployed from a 12-meter extendable boom mounted on the deployer (Figure 1.1). The integrated TSS is installed in the Space Shuttle Orbiter (Figure 1.2). Characteristics for the TSS are presented in Table 1.1.

The first mission, TSS-1, is scheduled for a 1988-89 launch. The 500 kg satellite will be deployed upward, away from the Earth on a 20 km tether during its approximately 36-38 hour mission (Figure 1.3). The 10 hour deployment includes two intermediate stops as can be seen in the timeline. The TSS is maintained at the deployed altitude for 18 hours, and is then retrieved over a 7-hour period. The tether will be conducting and will demonstrate the electromagnetic capabilities of tethers, producing up to 5 K volts as it cuts through the Earth's magnetic field. Five separate layers make up the composition of the Tether (Figure 1.4). The satellite will be electrically positive, collecting electrons from the ionosphere, and passing them to the Shuttle, which will emit the electrons with the help of an electron emitter. Science experiments on board TSS-1 will include electrical and magnetic field measurements, charged particle energy and spectra determinations, and DC magnetometry. At the Shuttle end of the tether are located vehicle charging and potential measuring and controlling instruments. Tether dynamics and plasma coupling mechanisms are also planned, as well as a series of ground-based observations of electromagnetic emissions from the tether. A list of these experiments along with their principle investigators appears as Figure 1.5.

TSS-2, the second tethered satellite system mission planned, will follow TSS-1 by 18-24 months. TSS-2 will be significantly different from TSS-1 in that the satellite will be deployed downward toward the Earth in

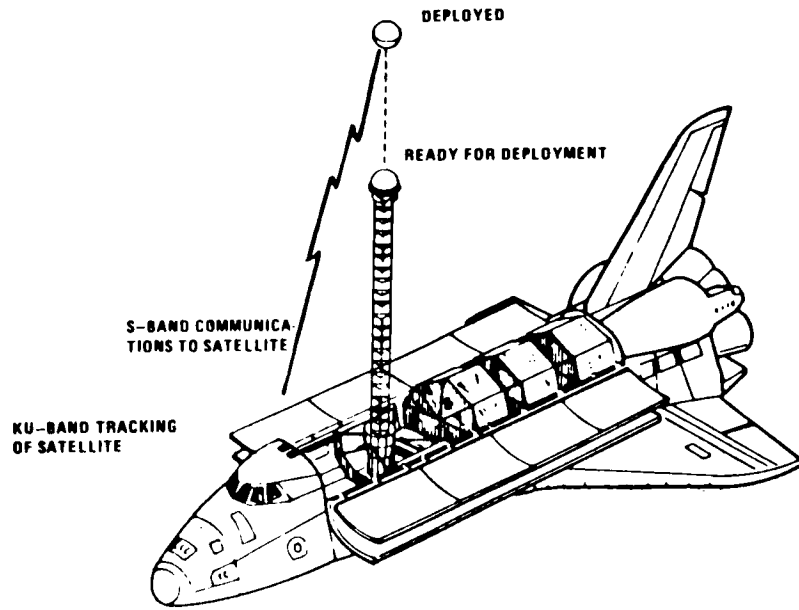

Figure 1.1. TSS-1 Satellite and Tether Attached to 12 Meter Extendable Boom

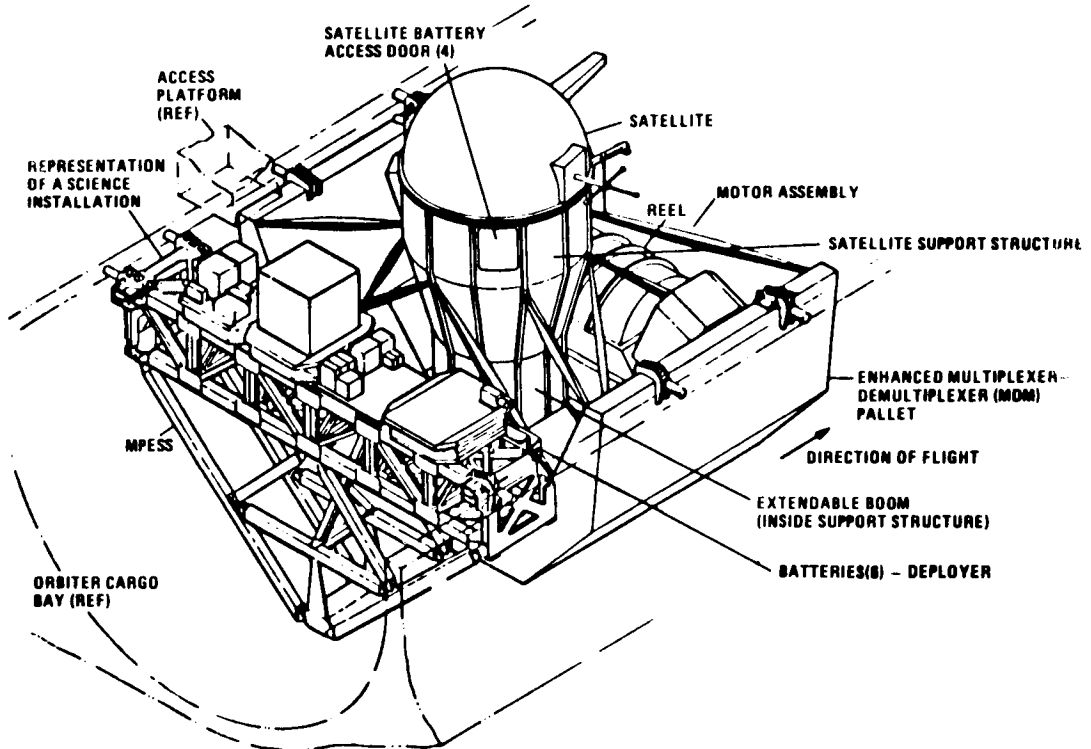

Figure 1.2. TSS-1 Configuration on Orbiter

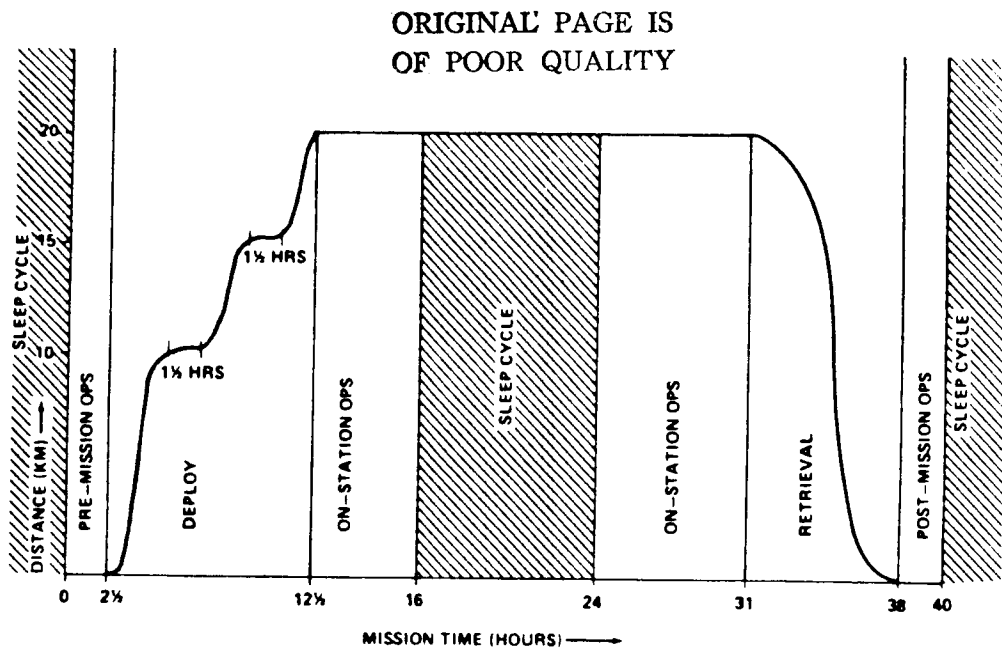

Figure 1.3. TSS-1 Mission Timeline

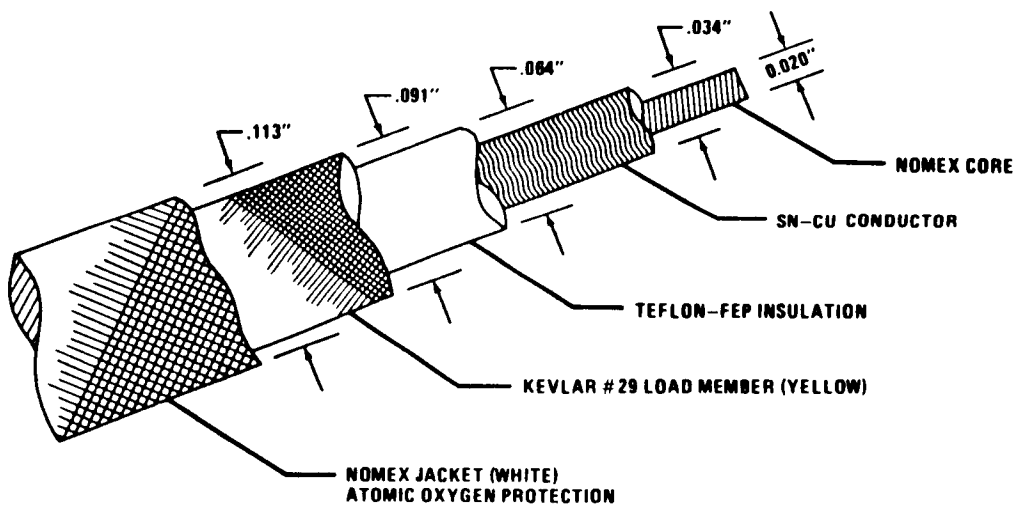

Figure 1.4. TSS-1 Conducting Tether Configuration

- 0 TSS PROJECT MANAGER - James Sisson

- 0 SATELLITE INSTRUMENTATION
 - o Electrodynamic Tether Effects - Marino Dobrowolny (CNR)
 - 3 Axis Dipoles - A.C. Electric Fields & Electrostatic Waves
 - 2 Axis Search Coils - A.C. Magnetic Fields
 - (2) Langmuir Probes - e^- Density, e^- Energy, Potential Distribution

 - o Plasma Electrodynamics - Nobie Stone (MSFC)
 - Differential Ion Flux Probe - Ion Energy Temperature and Density vs. Incidence Angle
 - (8) Soft Particle Energy Spectrometer - Charged Particle Energy Distribution and Space Potential

 - o Magnetic Fields - Franco Mariani (University of Rome)
 - Triaxial Fluxgate Magnetometer - Vector Magnetic Fields

- 0 ORBITER INSTRUMENTATION
 - o Vehicle Charging and Potential - Peter Banks (Stanford)
 - (2) Spot Charge and Current Probes - Local Current and Potential
 - Spherical Langmuir Probe - Vehicle Potential, Ion Density and Temperature
 - Fast Pulse Electron Gun

- 0 ELECTRODYNAMIC THEORY
 - o Plasma Couplings Studies - Adam Drobot (SAI)

- 0 TETHER DYNAMICS
 - o Dynamic Noise Studies - Gordon Gullahorn (SAO)
 - o Dynamic Noise Studies - Silvio Bergamaschi (University of Padova)

- 0 GROUND BASED OBSERVATIONS
 - o EM Emissions - Robert Estes (SAO)
 - ELF Receivers - Detect Tether Generated Emissions at ELF
 - Magnetometers - Detect Tether Generated Emissions at ULF

Figure 1.5. Tethered Satellite System Principal Investigation Science and Principal Investigators

ORIGINAL PAGE IS
OF POOR QUALITY.

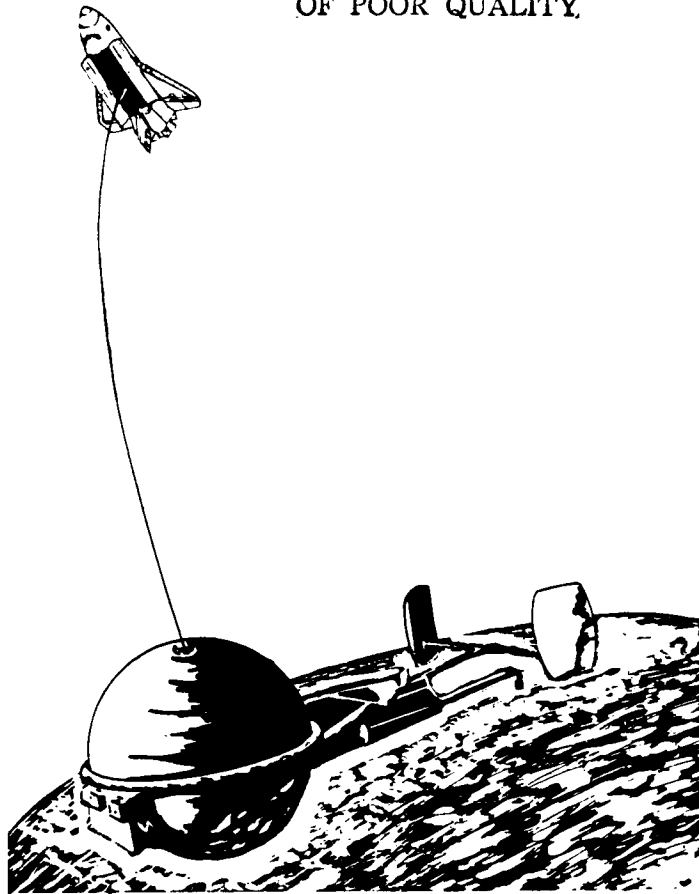

Figure 1.6. TSS-2 Mission Scenario
(Aerothermodynamic Mission)

order to complete a series of aerothermodynamic measurements in the region of 130 km altitude above the Earth (Figure 1.6). The satellite, which will be "towed" on a 100 km non-conducting tether, will be modified with aerodynamic surfaces for proper maneuvering control in the denser atmosphere. TSS-2 will provide a unique capability for upper atmosphere measurements as these types of measurements can only be accomplished presently with sounding rockets, and then only over short intervals of time and space.

TSS-3 will be similar to TSS-1, having an electrodynamic tether and being deployed upward. There will also be an 18 to 24 month re-processing period between the second and third missions.

TABLE 1.1 TETHERED SATELLITE SYSTEM CHARACTERISTICS

<u>Parameter</u>	<u>Satellite</u>	<u>Deployer</u>
Maximum Total Mass (kg)	500	4200 (TSS-1)
Scientific Payload Mass (kg)	60 to 80	500
Payload Volume	Negotiable (1.5 m Diam.)	Negotiable (Space- lab MDM Pallet)
Temperature (°C)	-10 to +50	Negotiable
Thermal Control (Watts)	50 (Passive)	5 Coldplates @1500
Power @ 28 + 4 VDC:		
Average (Watts)	50	2,300
Peak (Watts)	100	29,300
Energy (Whs)	900 to 2000	93,200
Data:		
Telemetry (kbps)	16	32
Commands (kbps)	2	2
Operational Attitudes (km)	130 and above	Up to 100 km Tether
Orbital Inclination	28.5°	28.5°
Mission Duration (hr)	Approximately 36-38 Hours	
Position Determ. (Rel to Orbiter):		
Range	+1%	
Angular	+2°	
Attitude Control:		
Pitch, Roll	+2°	
Yaw	+3°	
Attitude Measurement	+0.1 to +0.3°	

References 2, 3, 4 and 9 (pp. 37-80) are the primary references for this section.

1.2 PROPOSED TETHER EXPERIMENTS

ORIGINAL PAGE IS
OF POOR QUALITY1.2.1 Small Expendable Deployer System

The Small Expendable Deployer System (SEDS) experiment will demonstrate the ability of a disposable tether to boost a payload from the Shuttle into an orbit at a total fuel savings. The initial demonstration experiment, scheduled for a 1989 launch, will consist of a disposable Spectra polyethylene tether in a Get Away Special (GAS) canister aboard an MPSS pallet. The tether diameter will be 0.8 mm, and will support a simple bulk mass of 100-150 kg. The total SEDS mass (less the end mass) is about 100 kg. In operational use, a SEDS system would have a mass of under 200 kg and would increase the effective STS payload capacity by anywhere from 1400 to 3600 kg depending on the details of the mission. The system will be capable of changing the bulk mass orbit perigee and apogee by 20 and 280 km, respectively, using a 20 km tether. A schematic of SEDS is shown in Figure 1.7. The tether, which will be wound onto a spool, will be severed after the deployment is complete. Initial deployment will occur with springs or the Shuttle RMS and then continued by firing of the Shuttle RCS thrusters. At a separation of approximately 200 meters, Coriolis forces will continue the separation. SEDS is currently in the demonstration mission definition phase.

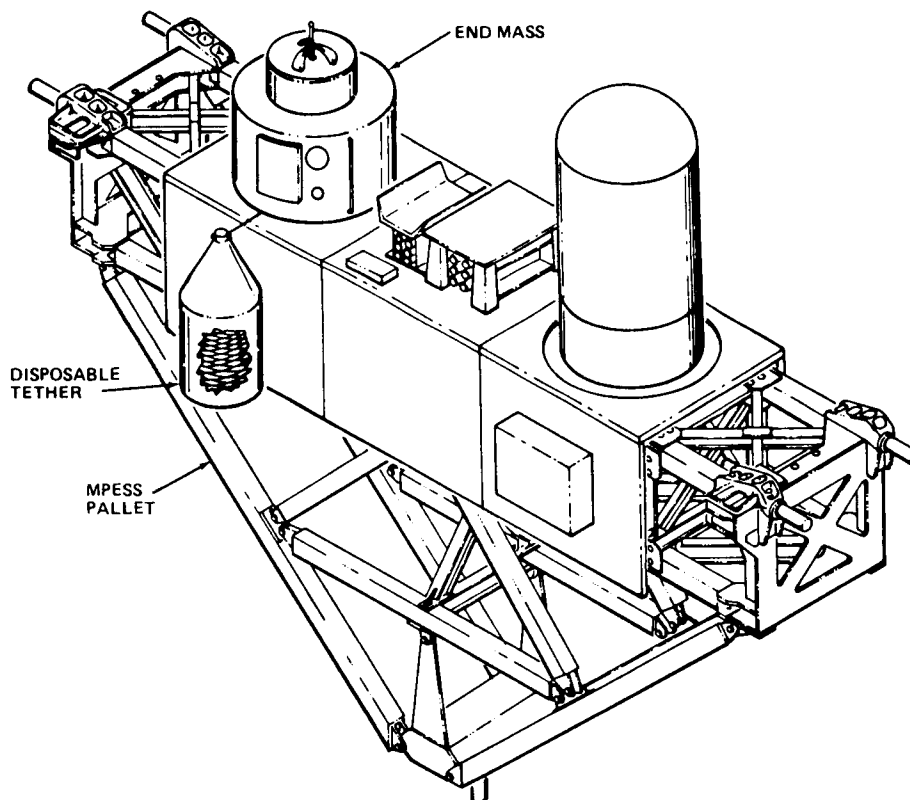

Figure 1.7. SEDS System Integrated to an MPSS Pallet
1-9

1.2.2 Plasma Motor Generator

The Plasma Motor Generator/Proof of Flight (PMG/POF) Experiment is a low cost "Payload of Opportunity" for flight on the Shuttle Orbiter using the Hitchhiker-G carrier. The objective of this experiment is to provide engineering verification of key physical processes involved in the operation of proposed PMG systems as soon as possible. A summary chart of the PMG/POF characteristics appears as Figure 1.8.

Early verification of the predicted performance of hollow cathodes (the provision of adequate conduction of large currents between the ionosphere and each end of an electrodynamic tether wire) is needed to guide Tether Application studies of 20 kw to 200 kw PMG systems. The primary unknown in the operation of a PMG system is the ability of the hollow cathode "brushes" to connect the tether "armature" to the ionospheric current path. The numerous variables involved in theoretical computations of the relevant plasma physics processes result in considerable uncertainty. Only direct measurements in orbit of the induced VXB voltage, current coupling, and ionospheric circuit impedance can provide adequate verification of the calculated effects.

Initial verification of these critical issues can be obtained prior to the availability of the Tethered Satellite System (TSS) by flying the 100 kg/200 meter/10 watt PMG/POF "non-tether" experiment. In this experiment, a 25 kg Far End Package (FEP), containing a hollow cathode system, is deployed at the end of an insulated #32 AWG umbilical wire. This wire connects the FEP hollow cathode system to another hollow cathode system at the Orbiter. The 200-meter wire length is long enough to provide an adequate induced voltage and separation from spacecraft wake effects, while still being short enough to avoid complex tether deployment, stabilization, and retrieval systems. The deployed wire and FEP are jettisoned at the completion of the experiment.

The results obtained from initial flights (now scheduled for HHG-2 and HHG-3) will also provide a basis for planning larger scale investigations using the TSS and expanded PMG/POF type experiments. These growth experiments could be flown at 6-month intervals, using the HHG carrier to

provide a low cost sequence of data points. Due to indefinite slippage of the 1986 launch of HHG-2, alternative launch possibilities on sounding rockets or unmanned orbital missions are being investigated. Upon resumption of Shuttle launches, additional PMG/POF experiments are proposed to extend the measurements to higher currents and voltages. If the SEDS deployer becomes available, 50 amps at 500 volts, using 2 km of #12 wire plus the 10 km SEDS "leader", is the final goal for the fifth flight. Any of the flights may be completed away from the Shuttle by releasing the tethered Near End and Far End Packages into orbit, if required by safety considerations.

1.2.3 Kinetic Isolation Tether Experiment

The Kinetic Isolation Tether Experiment (KITE) is a proposed Space Shuttle flight experiment intended to demonstrate the feasibility of providing attitude control to a space platform by varying the attachment point of a tether. Offsetting this point would cause the tether tension force to be offset from the platform center of mass, thus producing an external torque. The KITE experiment envisions a small (approximately 1000 kg) subsatellite via tether in a gravity gradient stabilized orientation. The tether length will vary from 1 to 5 km. A microprocessor and momentum wheel will be employed to control the tether attachment point. This project is in the demonstration mission definition phase with laboratory modelling presently being conducted at Stanford University.

PMG/POF CHARACTERISTICS60 kg Total Mass

Far End Package (FEP): 25 kg, 15" dia x 10" high

- o 0.5 M² Passive Collection Area
- o 1 A Hollow Cathode Plasma Neutralizer (Battery)
- o Power Supply & Controller for Hollow Cathode
- o Spool with 200 M #32 AWG Copper Wire
- o Argon Gas Supply & Controller

200 Meter Wire: 0.4 kg, Teflon Insulation, 2 lb. "Test"
with 4 lb. Breakaway

Near End Package (NEP): 30 kg, 16" dia x 28" high

- o Retains FEP Until Release for Deployment
- o 1 A Hollow Cathode Plasma Neutralizer
- o Power Supply & Controller for Hollow Cathode
- o Variable Load & Precision Ammeter
- o Power Supply to Drive Motor Mode Current
- o Programmable Micro-Processor Controller
- o Wire Cutter for Jettison
- o Xenon/Argon Gas Supply & Controller
- o Ground Test Plug
- o Interface & Control Plug: (HHG Standard)
- o Deployment Ejection System (Fixture Mounted on NEP)

Deployable by Spring Ejection (Could Use RMS or EVA/MMU if Easier)
Centrifugally Stabilized @ 1 Degree/Sec =
1.5 N Tension

via STS Orbiter: Station-Keeping 200 M (-Z)
(OMS) Delta-V 3.5 M/sec
Roll 1 deg/sec to keep FEP @ +Z + 30 deg

Deployment Simulated Successfully at NASA-JSC & Tested in Zero-G Airplane

Tension During Swinging (Max)	3.0 N
Tension During Swinging (Avg)	1.5 N
Tension During Ejection	<0.1 N

Jettison at End of Experiment Into Non-Recontacting Orbit

From 250 km Orbit, Rapid Decay of Jettisoned Package
Decays 1 km Below Orbiter by First Crossing
Reenters in 25 hr.

NEP With All Data Recorded Returned to Landing by STS Orbiter

Figure 1.8. Plasma Motor Generator/POF Characteristics

1.3 UNITED STATES TETHER STUDIES

Following is a summary of tether studies being conducted by various organizations in the United States under contract to NASA. The list is grouped by NASA field center location.

Title: Remote Tethered Docking
NASA Center: MSFC
Contract Number: NAS8-36602
Contract Monitor: Chris Rupp
Contractor: The Charles Stark Draper Laboratory, E. Bergmann
Abstract: Develop algorithm for Orbiter docking to passive and active end effector tethered from the Space Station.

Title: Tether Released Recovery System
NASA Center: MSFC
Contract Number: NAS8-35096
Contract Monitor: Chris Rupp
Contractor: General Electric Company, Dwight Florence
Abstract: To study modification of an available reentry vehicle to be deployed by tether.

Title: Tether Simulations
NASA Center: MSFC
Contract Number: NAS8-36673
Contract Monitor: Chris Rupp
Contractor: Control Dynamics Company, John Glaese
Abstract: To develop simulation programs for dynamic behavior of tethers in various specific tether missions.

Title: Getaway Tether Experiment
NASA Center: MSFC
Contract Number: NAG8-586
Contract Monitor: Chris Rupp
Contractor: The University of Alabama in Huntsville, M. Greene
Abstract: To deploy twin satellites that separate after deployment by a conducting tether.

Title: Constellation Dynamics
NASA Center: MSFC
Contract Number: NAS8-3666
Contract Monitor: Georg von Tiesenhausen
Contractor: Center for Astrophysics Harvard-Smithsonian, E. Lorenzini
Abstract: To define the dynamic behavior of three, four, and n-body tethered constellations.

Title: Metallized Kevlar
NASA Center: MSFC
Contract Number: NAS8-35268
Contract Monitor: Georg von Tiesenhausen
Contractor: Materials Concepts, Inc., R. F. Orban
Abstract: To construct a production line for conducting tethers consisting of metallized Kevlar filaments.

Title: Tether Deployment Monitoring Systems
NASA Center: MSFC
Contract Number: NAS8-36268
Contract Monitor: Georg von Tiesenhausen
Contractor: ANCO Engineers, Inc., P. Ibanez, A. Levi
Abstract: To verify concept of attaching small instrument modules to a tether during deployment to verify tether shape.

Title: Kinetic Isolation Tether Experiment
NASA Center: MSFC/ARC
Contract Number: NCC2-389
Contract Monitor: James K. Harrison/Larry Lemke
Contractor: Stanford University, J. David Powell
Abstract: To develop an instrumented tethered platform with variable orientation and to measure force limits.

Title: Tethered Space Station Platform and Shuttle Payload Launch
NASA Center: MSFC
Contract Number: NAS8-36617
Contract Monitor: James K. Harrison
Contractor: Ball Aerospace Systems Div., Dan McMann
Abstract: Engineering and cost/benefit analysis of tethered Space Station platforms and of tethered Orbiter payload deployments.

Title: Tethered Orbiter and OTV Deployment from Space Station
NASA Center: MSFC
Contract Number: NAS8-36616
Contract Monitor: James K. Harrison
Contractor: Martin Marietta Aerospace, B. Woodis
Abstract: Engineering and cost/benefit analysis of tethered deployment of Orbiter and OTV from Space Station.

Title: Tethered Energy Storage System
NASA Center: MSFC
Contract Number: NAS8-36616
Contract Monitor: James K. Harrison
Contractor: Martin Marietta Denver Aerospace, Bill Woodis
Abstract: To investigate tethered energy storage concepts.

Title: ULF/ELF Tether Antenna
NASA Center: MSFC
Contract Number: NAG8-551
Contract Monitor: Chris Rupp
Contractor: Smithsonian Astrophysical Observatory, R. Estes
Abstract: To analyze and develop an ultra-low and extremely low frequency electrodynamic tether antenna system.

Title: Small Expendable Deployer System
NASA Center: MSFC
Contract Number: NAS8-35256
Contract Monitor: James K. Harrison
Contractor: Energy Science Laboratories, J. Carroll
Abstract: To develop and test a tether deployment system without retrieval capability for small and intermediate size payloads.

Title: Tether Crawler System
NASA Center: MSFC
Contract Number:
Contract Monitor: Georg von Tiesenhausen
Contractor: In-House Study, Professor F. R. Swenson
Abstract: To develop a tether crawler system used to position experiment modules at various tether locations.

Title: 200 kW Plasma Motor Generator
NASA Center: JSC
Contract Number:
Contract Monitor: Jim McCoy
Contractor: Ball Brothers, Cal Rybak
Abstract: Engineering design study of the plasma motor generator concept for both power and thrust generation, including reversible power operation for power storage.

Title: 8 kW Orbit Reboost System
NASA Center: JSC
Contract Number:
Contract Monitor: Jim McCoy
Contractor:
Abstract: Preliminary design study of a light version of the PMG for orbit maintenance of low altitude solar array powered or other high drag spacecraft. Primary emphasis will be integration and operation with existing or planned s/c concepts, Space Station, free-flying platforms.

Title: Tethered Propellant Resupply Depot Study
NASA Center: JSC
Contract Number: NAS9-17422, NAS9-17059
Contract Monitor: Ken Kroll
Contractor: Martin Marietta Denver Aerospace, Dale Fester
Abstract: This study examines the use of a tether to simplify fluid transfer for OTV propellant resupply.

Title: Shuttle Tethered Aerothermodynamic Facility
NASA Center: LaRC
Contract Number:
Contract Monitor: Paul Siemers
Contractor: In-House Study and Analytic Mechanics, Henry Wolf
Abstract: A tethered system concept which provides steady-state aerothermodynamic data of the upper atmosphere between 90-130 km altitude.

Title: Tether Applications In the Space Station Era
NASA Center: JPL
Contract Number: NAS7-100
Contract Monitor: Paul Penzo
Contractor: In-House Study
Abstract: Assess system and technology needs to support tether applications, Earth orbital and planetary, in the Space Station era.

Title: Beam Plasma Interaction Data Base
NASA Center: LeRC
Contract Number: NAG3-620
Contract Monitor: Joe Kolecki
Contractor: University of Alabama in Huntsville, Chris Olsen
Abstract: Interaction of electron and ion beams with the ambient plasma at GEO and LEO.

Title: Electrodynamic Tether Device Characterizations
NASA Center: LeRC
Contract Number: NGR-06-002-112
Contract Monitor: Joe Kolecki
Contractor: Colorado State University, Dr. P. J. Wilbur
Abstract: Investigation of VI characteristics of plasma contactors as electron collectors in ground-based vacuum facilities.

Title: Electrodynamic Tether Device Characterization
NASA Center: LeRC
Contract Number:
Contract Monitor: Joe Kolecki
Contractor: LeRC In-House, Dr. M. Patterson
Abstract: Investigation of VI characteristics of plasma contactors as electron collectors in ground-based vacuum facilities.

Title: Tether Power System Study
 NASA Center: LeRC
 Contract Number: NAS3-24649
 Contract Monitor: Joe Kolecki
 Contractor: MIT, Dr. M. Martinez-Sanchez
 Abstract: A conceptual design of a high power electrodynamic tether system.

Title: Tether Plasma Interactions and Power Plant Feasibility
 NASA Center: LeRC
 Contract Number: NAS3-23881
 Contract Monitor: Joe Kolecki
 Contractor: S-Cubed, Dr. I. Katz
 Abstract: Improve and validate the existing physics model of electron collection by a plasma contactor. Predict operational parameters for high power tether systems with plasma contactors. Both objectives use the NASCAP-LEO computer code.

Title: Plasma Turbulence Generated by Tether Current Flow
 NASA Center: LeRC
 Contract Number: NAG3-681
 Contract Monitor: Joe Kolecki
 Contractor: MIT, Dr. D. Hastings
 Abstract: A theoretical study of turbulence effects in a contactor plasma cloud.

1.4 ITALIAN TETHER STUDIES

1.4.1 Science and Applications Tethered Platform Advanced Studies

The first phase of the Italian study on tether applications in space has examined a number of intriguing concepts. In order for these concepts to be viable, however, a number of dynamical and technological

problems must first be investigated. Advanced demonstrations would provide the confidence needed to initiate a full-scale effort devoted to the implementation of some of these concepts on the Space Station.

Three independent demonstrations were studied:

1. The Space Elevator
2. The Pointing Platform
3. Complex Multifunction Tethers

1.4.1.1 Tethered Space Elevator Study

As a result of a study of applications of tethers to the Space Station carried on by Aeritalia, under contract to Italy's National Space Plan, an intriguing concept was selected as a candidate for a demonstration flight by the Space Shuttle. This is the tethered Space Elevator, which is an element able to move between both ends of a tether, and can be used for microgravity studies as well as transportation.

The most promising feature offered by the Space Elevator when used as a microgravity facility is the unique capability to control the gravity acceleration level as a function of time. This possibility has provoked great interest in the microgravity science community. Moreover, the utilization of the Space Elevator as a transportation facility, able to move along the tether and providing easy access between the two tethered bodies, could be the fundamental tool used in the evolution of tethered systems.

The proposed demonstration would be a proof-of-concept, rather than a full test of the Elevator, in a scaled-down configuration. An STS flight test would be significant as a means of validating the mathematical models which describe the dynamics and control and the key component designs. The system proposed for a Shuttle flight test of the Elevator concept is made up of three major elements: The TSS-deployer, the TSS-satellite and the scaled Elevator.

The scaled Elevator would be mounted on the tether, by means of the Shuttle RMS, once the satellite is far away from the deployer, and recovered before satellite retrieval. The primary engineering objective of this mission is to demonstrate the ability to control the Elevator motion and the overall system dynamics.

Engineering data would be measured during the mission to assess the attainable performance with reference to Elevator concept applications. At least four engineering experiment goals should be realized:

1. Measurement of the residual acceleration behavior as a function of time for several Elevator positions along the tether.
2. Measurement of the residual acceleration profile vs. time as a response to a commanded profile by Elevator motion control.
3. Measurement of the system dynamics response to the Elevator motion from the Shuttle to the satellite for a commanded velocity control profile.
4. Measurement of technical performance parameters of the Elevator drive mechanism.

1.4.1.2 Tethered Pointing Platform Study

Within a study of tether applications to the Space Station, initiated by Italy's National Space Plan and carried out by Aeritalia, particular emphasis is placed on the concept of a Tethered Platform, stabilized by control of the attachment point, to be used for Space and Earth observation.

Displacement control of the attachment point between the tether and an end body represents a new method of attitude control. This concept could be used by the Space Station to allow the attitude stabilization of a medium-size pointing platform, and even the Space Station itself.

The demonstration of this concept seems necessary and essential, due to the complex dynamics involved, in order to prove the feasibility of high precision pointing performance.

The system proposed for this demonstration by a Shuttle flight test consists of two major elements: The TSS-deployer and the scaled pointing platform. The scaled pointing platform could be a modified version of the TSS-satellite including all the hardware needed for this demonstration.

The primary engineering objective of this mission is to demonstrate the ability to perform high precision control of the pointing platform attitude. During the mission several engineering parameters would be measured to assess the attainable performance with reference to pointing platform concept applications. At least five experiment goals can be accomplished:

1. Measurement of attitude dynamics in the absence of attitude control.
2. Measurement of attitude dynamics in response to high precision control.
3. Measurement of attitude stabilization in response to induced dynamical disturbances.
4. Measurement of tether tension and tether angle as a function of time with respect to the scaled platform.
5. Measurement of displacement mechanism and control system performance.

1.4.1.3 Complex Tether Technology Study

The study of tether applications to the Space Station has been carried out by Aeritalia under contract to Italy's National Space Plan. A major conclusion of this study is that the development of permanent tethered facilities in space is dependent on the development of complex tethers which will be able to perform several functions (i.e., power transmission, data communication) and be resistant to long exposures to the space environment.

Analogous Earth cable technology suitable for performing several functions is well developed, but it does not seem directly applicable to

Space activities. In addition, the impact protection technology, developed for conventional space structures, must be adopted for the peculiar characteristics of such long cables. The demonstration of complex tether technology is therefore a prerequisite before we can effectively implement advanced tether applications in space.

The major requirement of this demonstration is simulation of the space environment. Specifically, such effects as pressure, temperature, radiation, and meteoroid/debris flux must be modelled. These effects can be well simulated in existing laboratories, hence the objective of this demonstration can be pursued by ground-based activities. The following steps outline the proposed demonstration procedure:

- a. Requirements identification, current technology assessment and analytical studies approach.
- b. Materials testing, functional elements testing and technologies development.
- c. Multifunction tether technology and configuration analyses.
- d. Sample fabrication and development tests.
- e. Verification of the tether's ability to satisfy its major functional requirements when subjected to the simulated space environment conditions.
- f. Cost and performance trade-off studies.
- g. Tether configuration definition.

1.4.2 University of Padova Tether Studies

The main area of study at the Institute of Applied Mechanics, University of Padova, Italy, is in the field of dynamics. Presently, the activity covers two basic areas of research:

1. Dynamics of TSS.
2. Future applications of tethers in space, including the motion, stability and control of tethered platforms.

1.4.2.1 Dynamics of TSS

Research in the area of TSS dynamics addresses the evaluation of dynamical noise to which the subsatellite is subjected due to tether elasticity. As a result of experiments to be performed on board TSS-1, the effects of perturbations transmitted to the satellite will be determined. This data will be used so that the tether can be simulated as an elastic continuum.

To this point in time, reliable estimates of tether material damping effects are lacking; thus, present activity includes the addition of energy dissipation terms in the dynamical models. The purpose of this effort is to evaluate system response to transient perturbations caused by the Shuttle, satellite, and environmental forces.

Experimental work is also likely to be performed in cooperation with other Italian universities. Tether mechanical properties, for example, are largely unknown. Experiments which help in the determination of these mechanical properties will be needed.

1.4.2.2 Future Applications of Tethers in Space

Studies on future applications of tethers in space have been undertaken both independently and in connection with Aeritalia's SATP (Science and Applications Tethered Platform). Presently, the main features of the orbital motion of the tethered space elevator and of the SATP itself during maneuvers are sufficiently known, so that future work will include the evaluation of long term or secular orbital perturbations, as well as attitude dynamics and control. The main source of orbit disturbances seem to arise from the upper harmonics of the Earth's gravitational field, the effects of which are now being investigated.

Attitude stability and control of the SATP with respect to torques coming from the tether will also be studied. Insight into stability of the SATP, however, cannot be gained without the evaluation of disturbances acting on the Space Station and from a better understanding of the damping role of the tether. Research into SATP stability and control will be advanced as we learn more about these disturbances.

SECTION 2

TETHER FUNDAMENTALS

**Tether
Fundamentals**

2.1 GRAVITY GRADIENT

2.1.1 General

Gravity-gradient forces are fundamental to the general tether applications of controlled gravity, and the stabilization of tethered platforms and constellations. The basic physical principles behind gravity-gradient forces will be described in this section. This description will be in three parts. The first will discuss the principles behind the general concept of gravity-gradient forces. The second will continue the discussion, addressing the specific role of these forces in controlled-gravity applications. The third will address their role in the stabilization of tethered platforms and constellations.

For the purposes of this discussion, it will be sufficient to describe the motion of the simple "dumbbell" configuration, composed of two masses connected by a tether. Figure 2.1 shows the forces acting on this system in orbit. When it is oriented such that there is a vertical separation between the two masses, the upper mass experiences a larger centrifugal than gravitational force, and the lower mass experiences a larger gravitational than centrifugal force. (The reason for this is described further on in the discussion.) The result of this is a force couple applied to the system, forcing it into a vertical orientation. This orientation is stable with equal masses, and with either of two unequal masses above or below the center of gravity. Displacing the system from the local vertical produces restoring forces at each mass, which act to return the system to a vertical orientation. The restoring forces acting on the system are shown in Figure 2.2.

Since the gravitational acceleration changes nonlinearly with distance from the center of the Earth, the center of gravity of the tethered system will not coincide exactly with its center of mass. The separation becomes more pronounced as the tether length increases. However, the separation is not dramatic for systems using less than very large tether lengths. Therefore, for the purpose of this discussion, it will be assumed that the center of mass coincides with the center of gravity. Furthermore, to facilitate an "uncluttered" discussion, the two masses will be assumed to be equal, and the tether mass will be ignored.

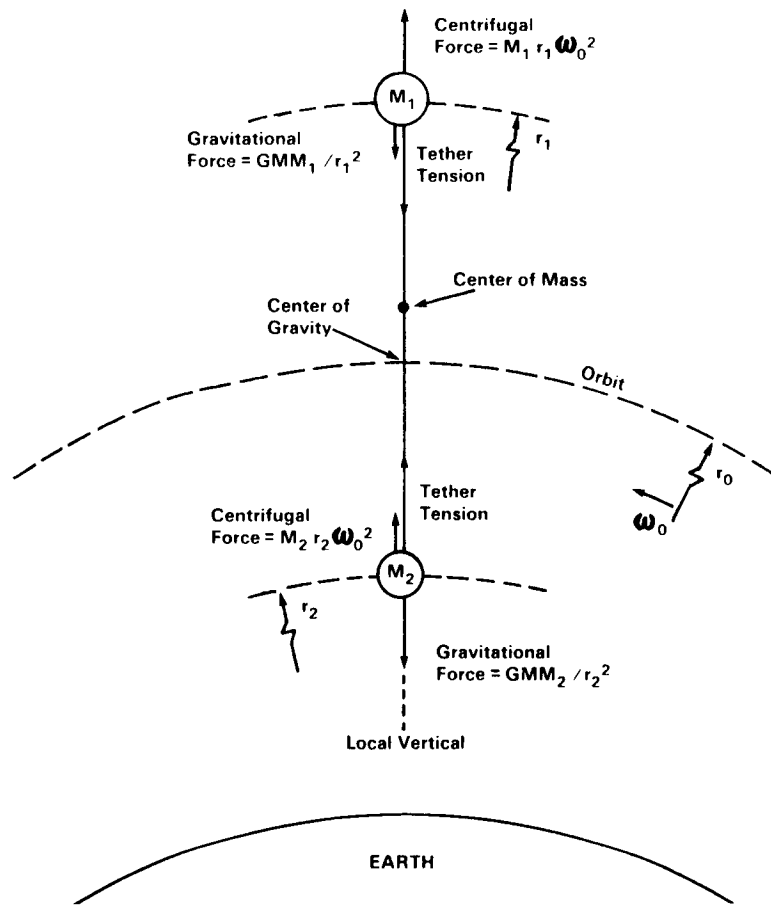

Figure 2.1. Forces on Tethered Satellites [Derived from Ref. 5, pp. 3-5]

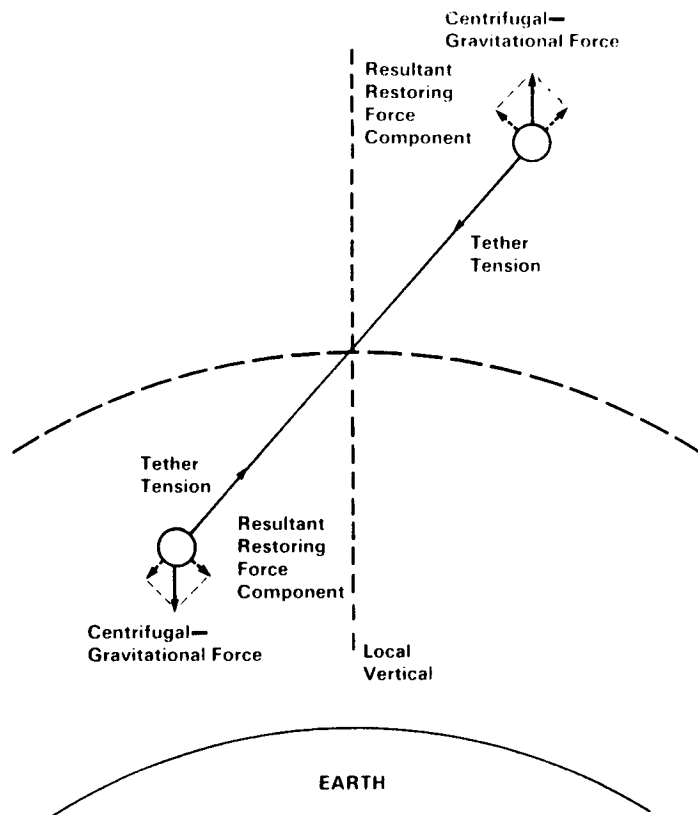

Figure 2.2. Restoring Forces on Tethered Satellites [Derived from Ref. 5, pp. 3-5]

The gravitational and centrifugal forces (accelerations) are equal and balanced at only one place - the system's center of gravity. The center of gravity (mass), located at the midpoint of the tether when the end masses are equal, is in free fall as it orbits the Earth, but the two end masses are not. They are constrained by the tether to orbit with the same angular velocity as the center of gravity. For the center of gravity in a Keplerian circular orbit:

$$\frac{GM_0}{r_0^2} = M_0 r_0 \omega_0^2 \quad \text{and}$$

$$\omega_0^2 = \frac{GM}{r_0^3} \quad ; \text{ where}$$

G = universal gravitational constant ($6.673 \times 10^{-11} \text{ Nm}^2/\text{kg}^2$),

M = mass of the Earth ($5.979 \times 10^{24} \text{ kg}$),

M_0 = total tether system mass (kg),

r_0 = radius of the system's center of gravity from the center of the Earth (m), and

ω_0 = orbital angular velocity of the center of gravity (s^{-1}).

Since $\omega_0 = \frac{V_0}{r_0}$ and

$$\omega_0 = \frac{2\pi}{T_0} \quad , \text{ where}$$

V_0 = orbital speed of the center of gravity, (m/s), and

T_0 = orbital period of the center of gravity (s),

$$V_0^2 = \frac{GM}{r_0} \quad \text{and}$$

$$T_0^2 = \frac{4\pi^2 r_0^3}{GM} \quad .$$

Note that the orbital speed, period, and angular velocity depend on the orbital radius, and are independent of the tether system mass.

If the two end masses were in Keplerian circular orbits at their respective altitudes and were not connected by a tether, their orbital speeds would be different than in the tethered configuration. For the upper mass:

$$\omega_1^2 = \frac{GM}{(r_o + L)^3} \quad \text{and}$$

$$v_1^2 = \frac{GM}{(r_o + L)} \quad ; \text{ where}$$

L = tether length from the center of gravity to the mass (m).

For the lower mass:

$$\omega_2^2 = \frac{GM}{(r_o - L)^3} \quad \text{and}$$

$$v_2^2 = \frac{GM}{(r_o - L)} .$$

It can be seen that without the tether, the upper mass would move at a slower speed, and the lower mass would move at a faster speed. The tether, therefore, speeds up the upper mass and slows down the lower mass. This is why the upper mass experiences a larger centrifugal than gravitational acceleration, and why the lower mass experiences a larger gravitational than centrifugal acceleration. The resulting upward acceleration of the upper mass and downward acceleration of the lower mass give rise to the balancing tether tension. They also produce the restoring forces when the system is deflected from a vertical orientation. The masses experience this tension as artificial gravity.

The artificial-gravity force and tether tension are equal to the gravity-gradient force. The gravity-gradient force on a mass, m , attached to the tether at a distance, L , from the system's center of gravity is equal to the difference between the centrifugal and gravitational forces on it. An approximate value for this force is given by

$$F_{GG} \approx 3L m \omega_o^2 .$$

For mass m above the center of gravity, the derivation is as follows:

$$F_{GG} = m \omega_o^2 (r_o + L) - \frac{GMm}{(r_o + L)^2}$$

$$\omega_o^2 = \frac{GM}{r_o^3}$$

$$F_{GG} = \left[\frac{GMm}{r_o^3} (r_o + L) \right] - \left[\frac{GMm}{(r_o + L)^2} \right]$$

$$= GMm \left[\frac{(r_o + L)}{r_o^3} - \frac{1}{(r_o + L)^2} \right]$$

$$= GMm \left[\frac{(r_o + L)^3 - r_o^3}{r_o^3 (r_o + L)^2} \right] .$$

Expanding the $(r_o + L)^3$ term and simplifying,

$$F_{GG} = GMm \left[\frac{3r_o^2 L + 3r_o L^2 + L^3}{r_o^3 (r_o + L)^2} \right]$$

$$= 3LGMm \left[\frac{r_o(r_o + L) + L^3/3}{r_o^3 (r_o + L)^2} \right] .$$

Since L is small compared to r_o for all but very long tethers, the equation can be simplified as follows:

$$F_{GG} \approx 3LGMm \left[\frac{r_o^2}{r_o^5} \right]$$

$$F_{GG} \approx 3Lm \left[\frac{GM}{r_o^3} \right] .$$

Since $\omega_o^2 = \frac{GM}{r_o^3}$,

$$F_{GG} \approx 3Lm \omega_o^2 .$$

For mass m below the center of gravity, the gravity-gradient force is simply

$$F_{GG} \approx -3Lm \omega_o^2 ,$$

indicating that the gravity-gradient force acts upward above the center of gravity, and downward below it. The force acts along the tether, and away from the center of gravity. Furthermore, the gravity-gradient acceleration and force increase as the distance from the center of gravity increases, and as the orbital radius of the center of gravity decreases. (A more rigorous derivation of this equation is presented in Appendix A of reference 25). Figure 2.3 presents a diagrammatic representation of the origin of gravity-gradient forces. Figures A.1 and A.2 of the Appendix show the tether tension (artificial-gravity force) and artificial-gravity acceleration as a function of tether length from the center of gravity for various system masses in LEO. Figure A.3 of the Appendix shows the tether mass and g-level as a function of tether length for a tether made of Kevlar 29 (both constant-cross-section and tapered tethers are given).

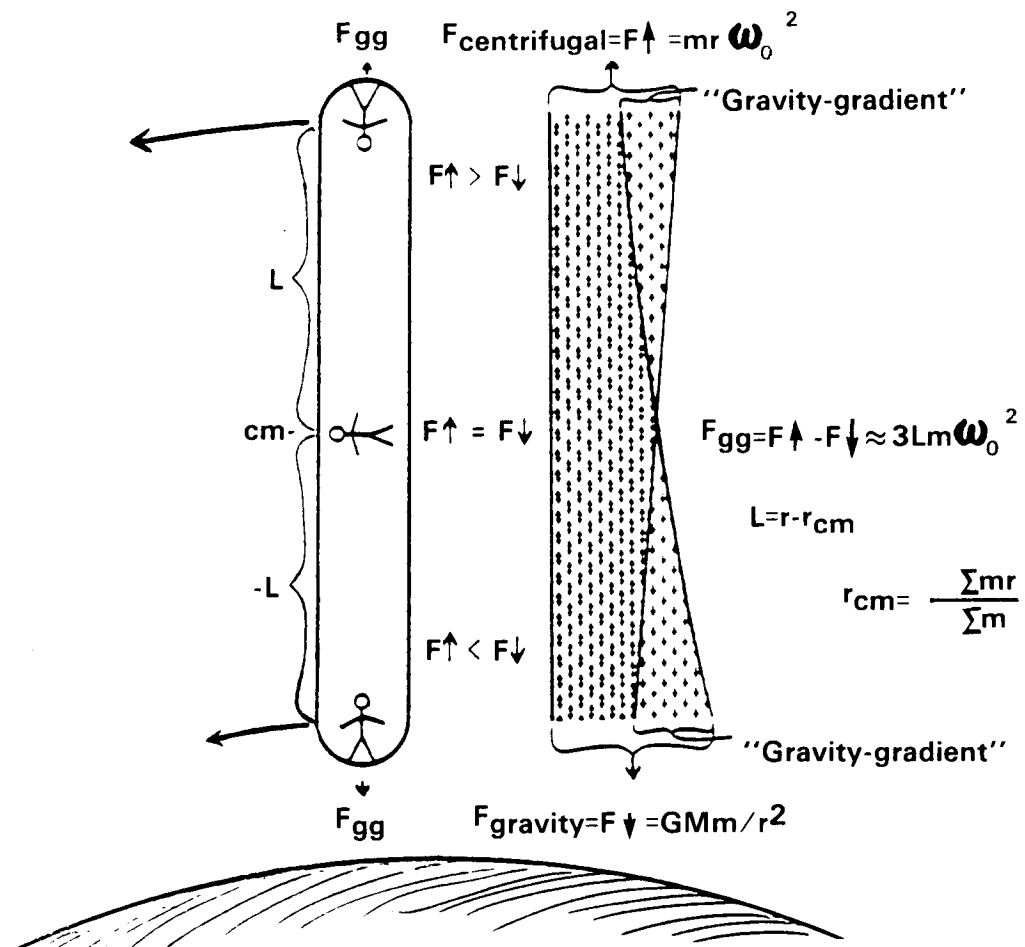

Figure 2.3. Origin of Gravity-Gradient Forces

[Derived from Ref. 1, p. 13]

Since the gravity-gradient force and acceleration in orbit vary with GM/r_o^3 (where M is the planetary mass), they are independent of the planet's size, and linearly dependent on its density. The acceleration is largest around the inner planets and the Moon ($0.3-0.4 \times 10^{-3}$ g/km for low orbits), and about 60-80% less around the outer planets. The gravity-gradient acceleration decreases rapidly as the orbital radius increases (to 1.6×10^{-6} g/km in GEO).

Although the vertical orientation of the tether system is a stable one, there are forces which cause it to librate (oscillate) about the vertical. These weak but persistent forces include the effects of the Earth's oblateness, differential atmospheric drag due to the different air densities encountered in the northward and southward passes of non-equatorial orbits and due to solar heating, and electrodynamic forces (for conducting tethers). Station-keeping and other rocket maneuvers would also contribute to driving (or damping) libration. The natural frequency for in-plane (in the orbital plane) librations is $\sqrt{3} \omega_o = 1.732 \omega_o$, and $2 \omega_o$ for out-of-plane librations. (A detailed derivation is contained in Appendix A of reference 25.)

Since both the displacement and restoring forces increase linearly with tether length, libration frequencies are independent of tether length. Therefore, the tether system will librate as a solid dumbbell (except for very long tethers, where the gravity gradient itself varies). Libration periods do increase at large amplitudes. Since the tether constrains the motion of the masses, the sensed acceleration is always along the tether. Furthermore, the tether can go slack if the in-plane libration angle exceeds 65° , or the out-of-plane libration angle exceeds 60° . The slackness can be overcome by reeling or unreeling the tether at an appropriate rate. Additional information on tether libration is presented in Figure A.4 of the Appendix.

Libration can be damped out by varying the tether length. It would be deployed when the tension was too high, and retracted when the tension was too low. Since the in-plane and out-of-plane librations have different periods, they could be damped simultaneously. Shorter-period,

higher-order tether vibrations could also be damped in this way. Additional information on tether control strategies is presented in Figure A.5 of the Appendix.

Since the portion of the tether at the center of gravity must support the tether as well as the masses, the mass of long tethers must be taken into account. To minimize the tether's mass, while maintaining its required strength, its cross-sectional area could be sized for a constant stress at all points along its length. The optimum design for very high tether tensions would be an exponentially tapered tether, with a maximum area at the center of gravity and minima at the end masses. (A detailed discussion of tapered tether design is provided in reference 7.)

In addition to the general areas of controlled gravity and tethered-platform and constellation stabilization, gravity-gradient effects play a fundamental role in applications related to momentum exchange and tethered-satellite deployment. These aspects are discussed in Section 2.3, entitled "Momentum Exchange."

References 1 (pp. 12-17) and 5 (pp. 1-18 through 1-20, 3-4 through 3-15) are the primary references for this section.

2.1.2 Controlled Gravity

As a first step in discussing the role of gravity-gradient effects in controlled-gravity applications, a few definitions will be established. The definitions used in this book will be those recommended by the controlled gravity panel at the tether applications conference in Venice, Italy in October 1985 (reference 10, pp. 56, 60). The term "controlled gravity" means the intentional establishment and control of the magnitude, vector properties, time dependence, and associated "noise" (uncertainty) of the acceleration field within a designated volume of space. In addition, the following definitions are also provided:

g = the acceleration on the equator at mean sea level on the Earth's surface (9.81 m/s^2);
 microgravity = $10^{-4} g$ and smaller;
 low gravity = $10^{-1} g$ to $10^{-4} g$;
 Earth gravity = $1 g$;
 hypergravity = greater than $1 g$;
 reduced gravity = microgravity and low gravity; and
 enhanced gravity = hypergravity.

There are two basic tether configurations which can be used to provide controlled-acceleration fields; gravity-gradient-stabilized configurations (rotating once per orbit in an inertial frame), and rotating configurations (rotating more rapidly than once per orbit). This section will cover gravity-gradient-stabilized configurations. Rotating configurations are discussed later in Section 2.2.

In an orbiting, vertically-oriented, gravity-gradient-stabilized tether system, composed of two end masses connected by a tether, all portions of each end mass experience the same acceleration, caused by the tether tension pulling on the end mass. This force is perceived as artificial gravity. As described before, its magnitude is proportional to the tether length from the system's center of gravity, and may be held constant or varied by deploying and retracting the tether. (For LEO, the gravity gradient is about $4 \times 10^{-4} \text{ g/km}$.) Its direction is along the tether and away from the center of gravity.

This same principle can be used in more complex configurations (constellations) of three or more bodies. For example, consider a three-body system stabilized along the gravity gradient. In this system, a third body is attached to a crawler mechanism ("elevator") on the tether between the two primary end masses. The crawler mechanism allows the third body to be moved easily to any point along the tether between the end masses. The acceleration field (artificial gravity) in the third body can be controlled easily by moving it up or down the tether. Its distance from the system's center of gravity determines the magnitude of the artificial gravity within it. This artificial gravity acts in the

direction along the tether and away from the center of gravity. The two end masses experience the artificial gravity determined by their distances from the center of gravity, as in the two-body system. The artificial gravity that they experience can also be held constant or varied by increasing or decreasing the tether length.

When positioned at the center of gravity, the third body could experience an acceleration field as low as about 10^{-8} g at the center of gravity, and 10^{-7} g and 10^{-6} g at distances from the center of gravity of 20 cm and 2 m, respectively. (Figure A.6 in the Appendix gives a breakdown of gravity level versus distance from the center of gravity for such a system at the Space Station altitude.) Using appropriate control laws, the third body's position could be automatically adjusted to produce a desired g-level time profile, or to minimize transient disturbing effects.

Gravity-gradient effects can also be used to control the location of the system's center of gravity. This would be a very useful capability for the Space Station if microgravity experiments were to be performed onboard. Two tethered masses would be deployed vertically from the Space Station - one above and one below. By controlling the tether lengths, the position of the center of gravity could be maintained at a particular point in the system, or moved to other points as desired. This means that the artificial gravity at all points in the system would be correspondingly controlled to a fine degree of resolution. For example, the center of gravity could be adjusted to coincide with the orbital altitude of a microgravity experiment, to provide it with the minimum possible acceleration field.

All of these system configurations allow the generation and fine control of a wide range of g-levels. Using appropriate control laws, tether lengths and the relative positions of system components can be varied to produce desired gravity fields and their time profiles, to minimize transient disturbances to the gravity field, and to carefully control the location of the system's center of gravity. In addition to all of this, tethers also provide two-axis stabilization of the system.

Gravity-gradient systems have several advantages over rotating systems. They can provide artificial gravity for large-volume structures more easily. Also, the gravity gradient and Coriolis accelerations within these volumes are much less than those produced in rotating systems. One result of this is a lower occurrence of motion sickness. However, one disadvantage of gravity-gradient systems is that they would require very long tethers to achieve g-levels approaching 1 g or more. By using a relatively small rotation rate with a tethered system, g-levels of 1 g or more can be achieved (with some increase in the Coriolis acceleration and gravity gradient). Figure A.7 of the Appendix provides additional information concerning the acceptable values of artificial-gravity parameters.

Tether technology suggests a number of exciting application possibilities. For example, since a tether can be used to attain a gravity field simply by deploying a counterweight along the gravity gradient, the establishment of a desirable low-level gravity onboard the Space Station appears practical. The tether mass would be a significant part of the station mass to produce 0.1 g (using a tapered 450 km tether), but would be relatively small for 0.05 g or less. The use of 0.01 - 0.1 g onboard the Space Station might permit simpler and more reliable crew-support systems (such as eating aids, showers, toilets, etc.), operational advantages (no floating objects, easier tool usage, and panels and controls which are operated as in ground training), and perhaps some long-term biological advantages. However, careful consideration will have to be given to the disadvantages of tether system mass and complexity, and the assurance of survival after meteoroid or debris impact. Such a system would also impact a microgravity laboratory, requiring it to be moved from the Space Station to the c.g. location.

A variable/low gravity laboratory module could be attached by a crawler mechanism to a tether deployed along the gravity gradient from the Space Station. A microgravity laboratory could also be built as part of the Space Station at its center of gravity. These labs could be used to examine the effects of microgravity and low gravity on both physical and biological processes. Some biological processes of interest would be

plant and animal growth, and human performance and medical processes (such as those related to the cardiovascular, skeletal, and vestibular systems). The gravity-threshold values for various biological phenomena could also be studied. Such physical processes as crystal growth, fluid science, and chemical reactions could be studied. Many experiments in materials science and manufacturing could be performed in these gravity ranges. (Figures A.8, A.9, and A.10 of the Appendix show comparisons of the microgravity environments produced by a number of different methods.) Liquid propellant storage and refueling facilities could be tethered to the Space Station. The artificial gravity produced by the tether would assist in propellant handling and transfer. (Figure A.11 of the Appendix shows the tether lengths necessary to allow propellant settling for the proper transfer of various propellants.)

These are but a few of the possible applications of the artificial-gravity environments produced by gravity-gradient effects. Detailed descriptions of applications utilizing these gravity-gradient effects are contained in the "Applications" section of this handbook. Note that, due to the wide variety of possible system configurations, all of these applications will not be contained in one category. There will be applications which overlap two or more categories, and which could be logically listed under any one of them. In these cases, a judgment will be made as to which category is the most appropriate for the particular application, and it will be listed in that category. The applications related to the artificial gravity produced by gravity-gradient effects will appear in the "Controlled Gravity" and "Space Station" categories of the "Applications" section, as appropriate.

References 5 (pp. 1-24 through 1-27) and 10 (pp. 55-60) are the primary references for this section.

2.1.3 Constellations

Gravity-gradient forces also play a critical role in the stabilization of tethered constellations. A tethered constellation is defined to be any generic distribution of more than two masses in space connected by

tethers in a stable configuration. They can be configured in either one, two, or three dimensions. All of the non-negligible forces or gradients available in low orbit come into play to stabilize these various configurations. The vertical gravity gradient has the strongest influence, but differential air drag, electrodynamic forces, the J_{22} gravity component (an harmonic of the Earth's gravitational potential), and centrifugal forces also contribute. Different configurations utilize different combinations.

Tethered constellations are divided into the two basic categories shown in Figure 2.4. These are "static" and "dynamic" constellations. Static constellations are defined as constellations which do not rotate relative to the orbiting reference frame (they do rotate at the orbital rate when referred to an inertial frame). Dynamic constellations, on the other hand, are defined as constellations which do rotate with respect to the orbiting reference frame. These two basic categories are subdivided

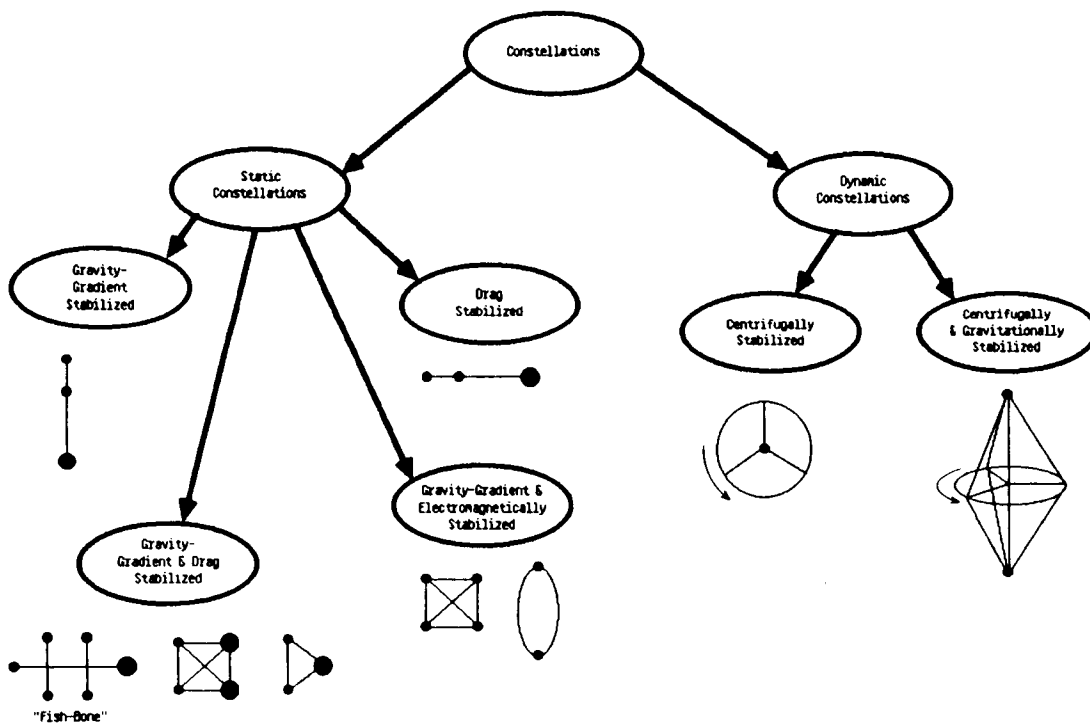

Figure 2.4. Types of Tethered Constellations [derived from Ref. 9, p. 296]

further. Static constellations include gravity-gradient-stabilized (one-dimensional, vertical), drag-stabilized (one-dimensional, horizontal), drag- and gravity-gradient-stabilized (two-dimensional), and electromagnetically and gravity-gradient-stabilized (two-dimensional) constellations. Dynamic constellations include centrifugally stabilized (two-dimensional), and centrifugally and gravitationally stabilized (three-dimensional) constellations. This section will address only the static constellations. Dynamic constellations are considered less desirable than static constellations, and are not being pursued at this time.

From the standpoint of stability and complexity, a gravity-gradient-stabilized, one-dimensional, vertical constellation is the most desirable configuration. A diagram, showing three bodies tethered in this configuration, is shown in Figure 2.5. Examples of this type of constellation were discussed in Section 2.1.2. These examples included the three-body configurations used for variable/low gravity and microgravity labs, and for the position control of the system center of gravity. Earlier discussion of vertical configurations (Sections 2.1.1 and 2.1.2) included descriptions of their dynamics (including libration). The dominant influence on these constellations is the vertical gravity gradient.

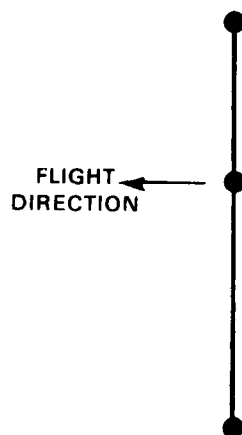

Figure 2.5. Example Configuration of a 1-D, Gravity-Gradient-Stabilized, Vertical Constellation

Stability in one-dimensional, horizontal constellations is provided by tensioning the tethers. (Such a constellation is depicted in Figure 2.6.) By designing such a constellation so that the ballistic coefficient of each of its elements is lower than that of the element leading it and higher than that of the element trailing it, a tension is maintained in the tethers connecting them along the velocity vector. The resulting differential drag on its elements prevents the constellation from compressing, and the tension in its tethers prevents it from drifting apart. In principle, there is no limit to the number of platforms which can be connected in this manner. However, it should be noted that drag takes orbital energy out of the constellation, shortening its orbital lifetime unless compensated by some form of propulsion.



Figure 2.6. Example Configuration of a 1-D, Drag-Stabilized, Horizontal Constellation

The fundamental parameter for one-dimensional, horizontal constellations is the differential ballistic coefficient of the two end bodies. In the case of a massive front body and a voluminous rear body (balloon), it is equal to the ballistic coefficient of the latter. Additional information on the dynamics and stability of such a constellation is provided in Figure A.12 of the Appendix. Figure A.13 of the Appendix contains calculated values of the maximum tether lengths for static stability along the local horizon, and orbital decay rates versus altitude for an example constellation with a ballistic coefficient of $10 \text{ m}^2/\text{kg}$ for the rear balloon (twice that of the Echo balloon). Results are strongly dependent on atmospheric density conditions. As these calculations show, tether lengths and orbital lifetimes are competing requirements, and are never sufficiently satisfied in the altitude range of interest. The vertical gravity gradient dominates the differential air

drag at the Space Station altitude and higher in such a way that the maximum horizontal tether length must be short, while at lower altitudes (150-200 km), where differential air drag becomes relatively strong, the orbital lifetime is very limited.

The "fish-bone" configuration was the first proposed two-dimensional constellation, and it utilizes both gravity-gradient and air-drag forces in order to attain its stability. A simple "fish-bone" constellation is depicted in Figure 2.7. For analytical purposes, this constellation can be reduced to an equivalent one-dimensional, horizontal constellation by lumping the overall ballistic coefficient of the rear leg (balloons plus tethers) and the front leg at the ends of the horizontal tether. Additional information on the stability analysis of the original "fish-bone" configuration shown in Figure 2.7 is presented in Figure A.14 of the Appendix. Figure A.15 of the Appendix contains calculated values of its stability limits versus altitude. Analysis has revealed that this configuration is even less stable than a comparable one-dimensional, horizontal constellation. The necessity of a massive deployer at the center of the downstream vertical tether subsystem greatly reduces the area-to-mass ratio of that subsystem. Without any modification, the "fish-bone" constellation has a stability (maximum allowable horizontal tether length) which is less than that of the single-axis, horizontal constellation.

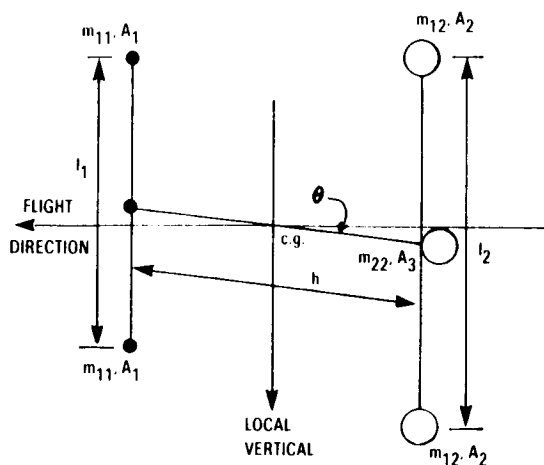

Figure 2.7. Example Configuration of a 2-D, "Fish-Bone" Constellation [Ref. 9, p. 301]

Two additional designs for a two-dimensional constellation, utilizing gravity-gradient and air-drag forces for stability, have been proposed. These drag-stabilized constellation (DSC) designs are depicted in Figure 2.8. With this type of configuration, the gravity gradient is exploited for overall attitude stability (the constellation's minimum axis of inertia must be along the local vertical), and differential air-drag forces are used to stretch the constellation horizontally for shape stability. The drag force is fully exploited to assure the minimum tension in the horizontal tethers, and not to counteract the gravity-gradient force as it does in the "fish-bone" configuration. Design parameters for DSC systems are presented in Figures A.16 and A.17 of the Appendix.

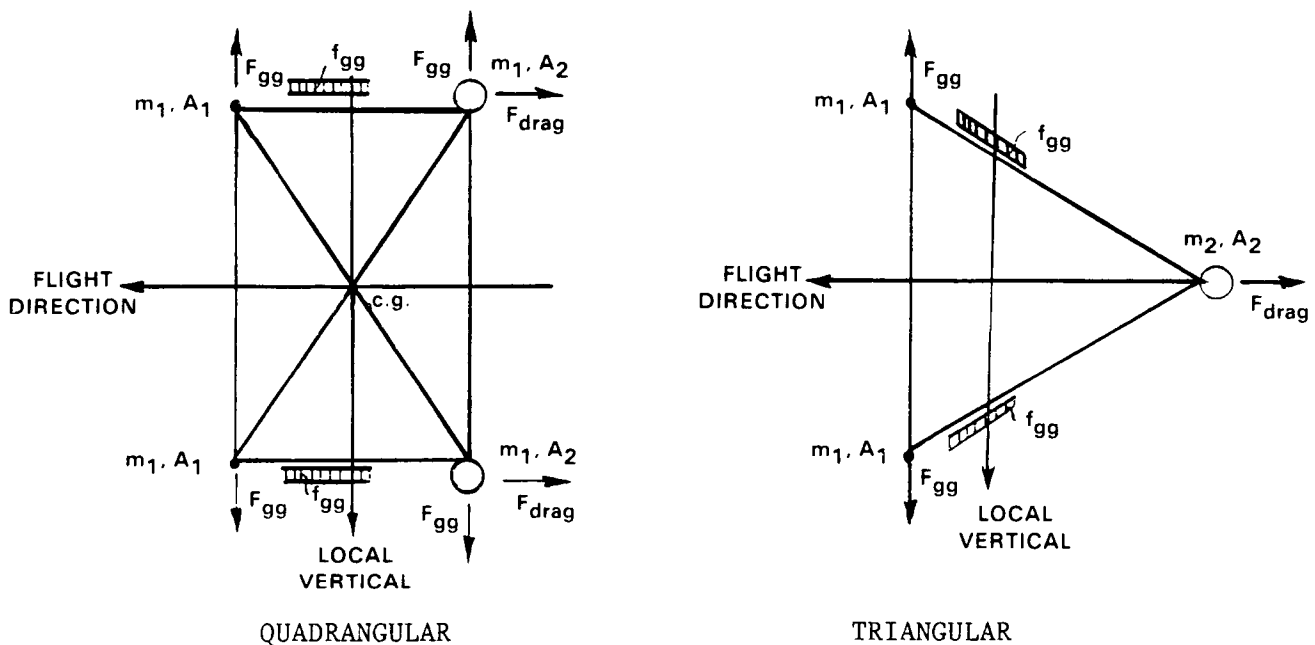

Figure 2.8. Two Designs of 2-D DSC Constellations Horizontally Stabilized by Air Drag [Ref. 10, p. 173]

Two designs for a two-dimensional constellation, utilizing gravity-gradient and electromagnetic forces for stability, have been proposed. These electromagnetically stabilized constellation (ESC) designs are shown in Figure 2.9. In these configurations, the gravity gradient is again used for overall attitude stability (the minimum axis of inertia is vertical) and electromagnetic forces are used to stretch the constella-

tion horizontally for shape stability. (These electromagnetic forces are discussed in detail in Section 2.4.) In the quadrangular configuration, current flows in the outer-loop tethers, interacting with the Earth's magnetic field, to generate electromagnetic forces on the sides of the outer loop. The current direction is chosen such that these forces push the tethers outward, tensioning them (like air inside a balloon). Although the shape is different in the pseudo-elliptical constellation (PEC) design, the same principle of electromagnetic tensioning of the outer-loop tethers is applied. The two lumped masses provide extra attitude stability without affecting the shape. In both configurations, the electromagnetic forces stretch the constellation in such a way that the resultant force is zero, so that the orbital decay rate is not increased. Design parameters for ESC systems are presented in Figures A.16, A.18, and A.19 of the Appendix.

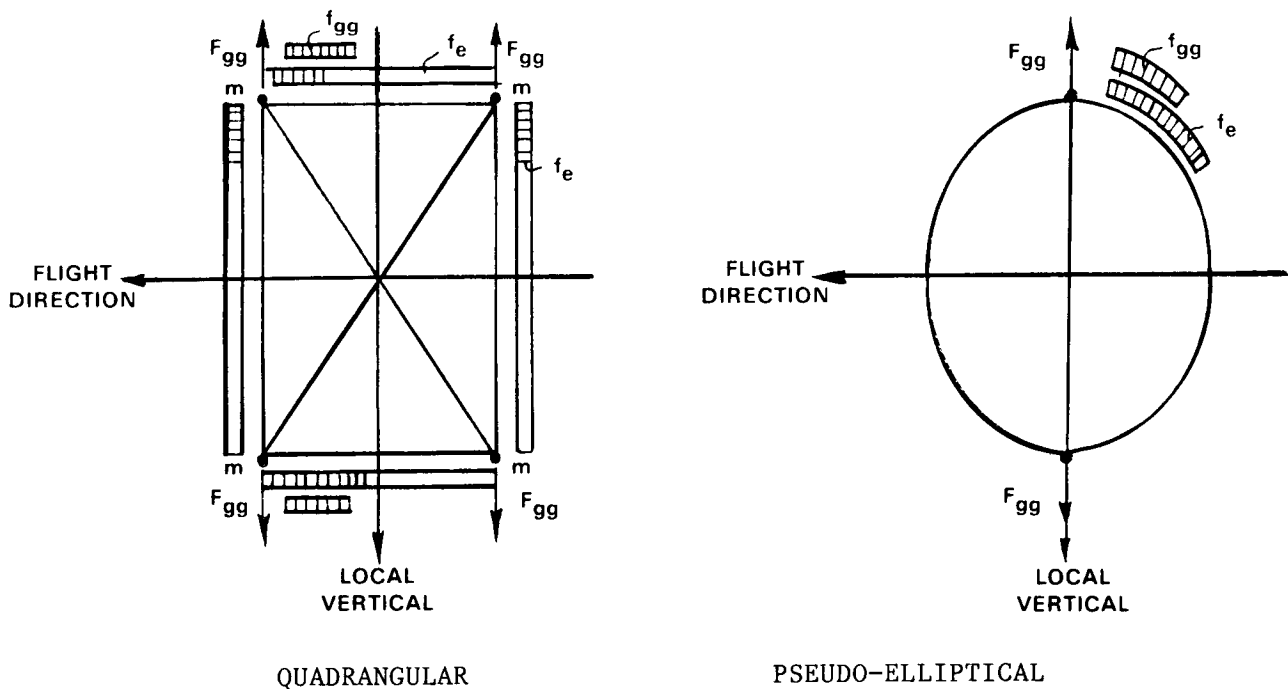

Figure 2.9. Two Designs of ESC 2-D Constellations Where Shape Stability is Provided by Electromagnetic Forces [Ref. 10, p. 174]

Preliminary conclusions on the design of two-dimensional constellations have been reached. The "fish-bone" constellations are less stable than the one-dimensional, horizontal constellations. "Fish-bone"

constellations are stable with very short horizontal tethers (less than 100 m at 500 km altitude). The alternative quadrangular DSC and ESC constellations (and PEC's for special applications) are much better. Suitable design parameters can provide good stability with a reasonably low power requirement for ESC's and feasible balloons for DSC's.

Typical dimensions for these constellations are 10 km (horizontal) by 20 km (vertical) with balloon diameters of about 100 m for DSC's, and a power consumption of about 7 kW for ESC's and PEC's. The ESC constellations have greater tension in the horizontal tethers than the DSC constellations, and an orbital decay which is smaller by an order of magnitude. ESC's are suitable for low inclination orbits. Since they tend to orient their longitudinal plane perpendicular to the Earth's magnetic field (B vector), an oscillation about the vertical axis at the orbital frequency is unavoidable. DSC's, on the other hand, are suitable for any orbital inclination. In the DSC's, the yaw oscillation occurs at high inclinations only, due to the Earth's rotating atmosphere.

There are several proposed applications for one-dimensional, vertical constellations. A three-body configuration could be used for microgravity/variable-gravity laboratories attached to the Space Station (discussed in Section 2.1.2) or the Shuttle. A three-body system could be used on the Space Station to control the location of the center of gravity (also mentioned in Section 2.1.2). A system of 3 or more bodies, attached to the Shuttle or Space Station, could be used as a multi-probe lab for the measurement of the gradients of geophysical quantities. A 3-body system could also be used as an ELF/ULF antenna by allowing a current to flow alternately in the upper and lower tether to inject an electromagnetic wave with a square waveform into the ionosphere. A space elevator (or crawler) for the Space Station is yet another application.

There are several proposed applications for two-dimensional constellations. An electromagnetically stabilized constellation could be used to provide an external stable frame for giant orbiting reflectors. Multi-mass constellations in general could provide separation of different activities, while keeping them physically connected (for power distribution, etc.).

These are some of the most popular applications proposed up to this point. Applications of these constellations will appear in a number of the categories of the "Applications" section, as appropriate.

References 5 (pp. 1-27), 9 (pp. 286-308), and 10 (pp. 150-203) are the primary references for this section.

2.2 ROTATION OF TETHER SYSTEMS

2.2.1 General

Tethers will almost always be involved in some form of rotational configuration. Any planet-orbiting tether system, by nature, will rotate about the planet at the orbit angular velocity. The combination of the centrifugal forces due to rotation and gravity gradient acting on the tether end masses causes it to be stabilized in a vertical position about the planet center of mass. In many interplanetary applications, rotation will be desired so as to cause an artificial-gravity environment or to create a centrifugally stabilized configuration.

2.2.2 Controlled Gravity

A tether-mass system may desire controlled gravity for a number of applications. These may range from an artificial-gravity environment for manned interplanetary missions to a controlled-gravity platform for industrial space applications. The calculation of the acceleration at a point for purely circular motion is presented here. With reference to Figure 2.9, we assume a point P (which would represent the mass) at a constant radius r (the tether) from the center of our rotation system.

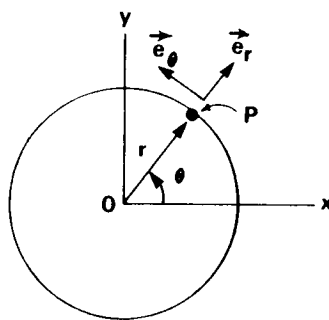

Figure 2.10. Circular Motion of a Point.
[Ref. 12, p. 40-41]

The acceleration can then be found by the expression:

$$\vec{a} = (-r\omega^2)\vec{e}_r + (r\dot{\omega})\vec{e}_\theta ;$$

where, \vec{a} = acceleration at the point P (m/s²),
 \vec{e}_r = unit vector in radial direction,
 \vec{e}_θ = unit vector in tangential (velocity) direction,
 r = radius (length of tether)(m),
 ω = angular velocity (rad/s),
 $\dot{\omega}$ = angular acceleration (rad/s²).

Notice that if the angular velocity is constant, the acceleration simplifies to

$$\vec{a} = (-r\omega^2)\vec{e}_r ;$$

where the negative sign indicates that the acceleration acts toward the center of rotation. A simple calculation follows.

Suppose we wished to calculate the gravity level at a manned module rotating about another "stationary" module with angular velocity of 2.0 rpm, attached by a tether of length 100 meters. The calculation is then:

$$\begin{aligned} a &= r\omega^2 \\ &= (100 \text{ m}) \left[\left(\frac{2 \text{ rev}}{\text{min}} \right) \left(\frac{1 \text{ min}}{60 \text{ sec}} \right) \left(\frac{2\pi \text{ rad}}{\text{rev}} \right) \right]^2 \\ &= 4.38 \text{ m/s}^2 . \end{aligned}$$

To calculate the gravity level (as compared to Earth's):

$$\begin{aligned} a &= \frac{4.38 \text{ m/s}^2}{9.8 \text{ m/s}^2} \\ &= 0.45 \text{ g} . \end{aligned}$$

Reference 12 (p. 40-41) is the primary reference for this section.

2.3 MOMENTUM EXCHANGE

2.3.1 General-Conservation of Angular Momentum

Tethers can have useful space applications by redistributing the orbital angular momentum of a system. A tether can neither create nor destroy system angular momentum, only transfer it from one body to another. Angular momentum is defined (for a rotating system, Figure 2.11) as,

$$\vec{h} = m\vec{r} \times \vec{v} = mr^2\vec{\omega};$$

where

\vec{h} = angular momentum of system ($\text{kgm}^2\text{s}^{-1}$),

m = mass of system (kg),

\vec{r} = radius vector from center of rotating coordinate system (usually the Earth) to system center of mass (m),

\vec{v} = velocity of system center of mass normal to r (ms^{-1}), and

$\vec{\omega}$ = system angular velocity (s^{-1}).

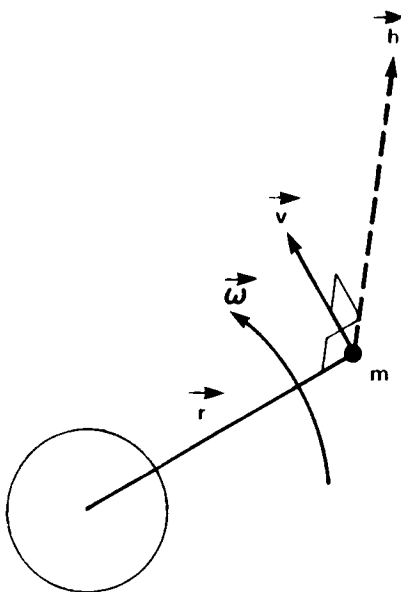

Figure 2.11. Angular Momentum in a Rotating System

In general, momentum exchange can be used for various tether applications using different momentum exchange techniques. These

techniques will be described first, followed by examples of their application. A useful chart is presented in the Appendix (Figure A.20) concerning momentum transfer.

2.3.2 Tether Payload Deployment

Consider a system composed of two bodies connected by a variable-length tether as in Figure 2.12.

If we wish to initiate a tethered deployment, such as deploying a payload (M_2) from the Shuttle (M_1), we must first provide an initial impulse to the payload to start separation. After a certain length of tether has been deployed, the masses are in sufficiently different orbits so that gravity-gradient and centrifugal forces continue the separation. (For an in-depth discussion of these forces, see Section 2.1.) If the two masses were not constrained by a tether, mass M_1 would obtain a lower orbital velocity and M_2 would obtain a higher orbital velocity in their new orbits. This is because as M_1 moves further away from the Earth's gravitational field, its potential energy is raised and its kinetic energy is lowered. For M_2 the exact opposite is true. Since the masses

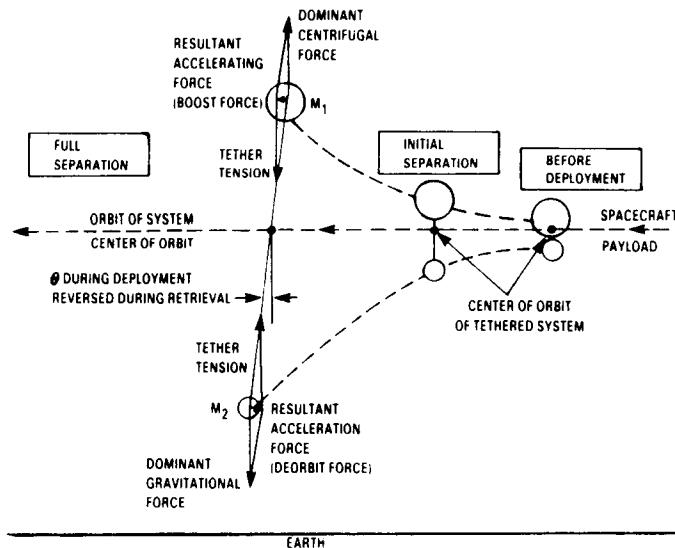

Figure 2.12. Tethered Deployment [derived from Ref. 13, p. 4)

are constrained by a tether, they also must move at the same orbital velocity. Mass M_2 , therefore, will "drag" mass M_1 along until libration occurs. Libration will continue due to the centrifugal, gravitational, and tether tension restoring forces.

In this case, mass M_1 gained angular momentum equal to an identical amount lost by M_2 . This amount of angular momentum transferred is equal to:

$$\Delta h = M_1 V \Delta R_1 = M_2 V \Delta R_2 \quad .$$

The momentum is transferred from M_1 to M_2 through the horizontal component of the tether tension. This tension is caused by the Coriolis term of the acceleration expression of the librating masses.

If the tether is now cut, the upper mass, M_1 , is boosted into an elliptical orbit having higher energy than it would have had due to its greater velocity. The point in the orbit where the tether is severed will correspond to the perigee of M_1 . The situation is exactly reversed for M_2 , which will be at its apogee at this point.

The preceding discussion explains the basic mechanics of momentum transfer in tethers. There are many variations of tethered deployment, all of which are beyond the scope of this text. Some of the more basic ones will be described here.

Static and dynamic tethered deployment are basically the same, except that static deployment occurs with the tether remaining under small angular displacements from the vertical, and dynamic deployments utilize large angular displacements. To implement a large angular displacement, tether tension is purposely kept low until a desired length is reached. When brakes are applied, a large angle prograde swing occurs. When the upper mass (payload) leads the lower mass, the tether is severed. In this way, an added boost due to the additional velocity of the prograde swing is accomplished.

Another method of tethered deployment is libration pumping. The tether is initially deployed, then alternately extended and retrieved in resonance with tether tension variations during libration. (In-plane libration causes these tension variations due to Coriolis effects.) Spin pumping is yet another method, whereby libration pumping is carried further to the point that the tether system is caused to spin. In both cases, the added energy increases the departure velocity of the payload, just as in the dynamic tethered deployment case. (See Appendix, Figures A.20, A.21.)

References 1 (pp. 13-21) and 13 (pp. 1-17) are the primary references for this section.

2.3.3. Orbit Variations

If the payload deployment described previously is carefully done, the orbits of both masses can be changed to one or both of their benefits. The Shuttle, for example, can boost a payload into a higher orbit and at the same time deboost itself back to Earth. Conversely, the Shuttle could perform a tethered deployment of its external tanks, whereby the tanks are deboosted back to Earth and the Shuttle is boosted to a higher orbit. Applications such as these are termed "momentum scavenging" since you are using excess momentum that would not have been utilized for a beneficial purpose. The trick with this approach is that you must have a use for this excess momentum. One major application which is described in the applications section of the handbook is the Space Station-Shuttle deboost operation. This is an excellent example where both masses benefit. Re-supply missions of the Space Station by the Shuttle are finalized by a tethered deployment of the Shuttle. In this way, the Space Station is boosted to a higher orbit and the Shuttle is de-boosted back to Earth. In order to utilize the additional momentum of the Space Station, tethered deployments of an OTV are alternated with those of the Shuttle. Fuel savings can be obtained by both Shuttle and OTV in this example. Figure A.22 of the Appendix contains some useful equations often used in calculations such as this.

Tethers can also be used to change orbit eccentricity. This is done by libration pumping of a tethered mass, phased as in Figure 2.13. At (1) the mass is fully extended, and libration commences. At (2), with the mass in a prograde swing, the retrieval motor pulls the spacecraft towards the mass, adding energy to the orbit (through the use of excess electrical energy transferred to the motor). At (3), which is the new apogee of the orbit, the tether length is at a minimum. At (4), with the mass in a retrograde swing, the tether is re-deployed, and the retrieval brakes are used to dissipate orbital energy in the form of excess heat. At (5), the new perigee, the mass is again fully deployed. This procedure is repeated until the desired eccentricity is reached. (See also Figure A.20, Appendix.)

Reference 13 (pp. 16-17) is the primary reference for this section.

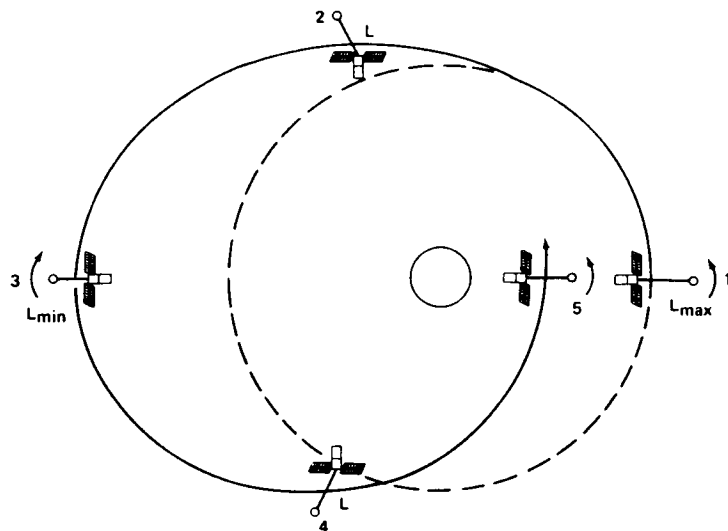

Figure 2.13. Orbit Eccentricity Change
[Ref. 13, p. 16-17]

2.4 ELECTRODYNAMICS

2.4.1 General

As a first step in discussing how tether systems can be used to generate various electromagnetic quantities, two important terms will be defined. Throughout this book, tether systems will be identified as "electrodynamic" if they rely on moving parts within the system to generate a desired electromagnetic quantity or effect.

The term "electromagnetic" will be used to identify tether systems which do not rely on moving parts within the system to generate electromagnetic quantities or effects. These systems typically rely on the electromagnetic interactions of an insulated, conducting tether with a planetary or interplanetary magnetic field and plasma. Of course these interactions result from the relative motion of the tether system through a magnetic field, but the primary motion is not a mechanical one, internal to the tether system.

The term "electrodynamic" will also be used to identify the overall category of all tether systems which generate any electromagnetic quantities or effects.

Electromagnetic systems can be designed to produce several useful effects by interacting with magnetic fields. They can be designed to produce either electrical power or thrust (either a propulsive thrust or a drag). They can also be designed to alternately produce electrical power and thrust. In addition, they can be designed to produce ULF/ELF/VLF electromagnetic signals in the upper atmosphere, and shape-stability for orbiting satellite constellations. Electrodynamic systems can be designed to produce electrical power.

2.4.2 Electric Power Generators

The discussion of electric power generation by tether systems will begin with electromagnetic systems in Earth orbit. Consider a vertical,

gravity-gradient-stabilized, insulated, conducting tether, which is terminated at both ends by plasma contactors. A typical configuration is shown in Figure 2.14.

As the tether system orbits the Earth, it cuts across the geomagnetic field from west to east at very high speeds (about 8 km/s if deployed from the Shuttle as shown in Figure 2.14). Due to this motion, the geomagnetic field induces an electromotive force (emf) across the length of the tether. This emf is given by the equation:

$$V = \int_{\text{along length of tether}} (\vec{v} \times \vec{B}) \cdot d\vec{l} \quad ;$$

where V = induced emf across the tether length (volts),
 \vec{v} = tether velocity relative to the geomagnetic field (m/s),
 \vec{B} = magnetic field strength (webers/m²), and
 $d\vec{l}$ = differential element of tether length - a vector pointing in the direction of positive current flow (m).

For the special case where the tether is straight and perpendicular to the magnetic field lines everywhere along its length, the equation for the emf simplifies to:

$$V = (\vec{v} \times \vec{B}) \cdot \vec{L} \quad ;$$

where \vec{L} = tether length - a vector pointing in the direction of positive current flow (m).

Using the definition of the vector cross product, the equation for the induced emf across the tether in this special case can also be written as:

$$V = L v B \sin \theta \quad ;$$

where θ = angle between \vec{v} and \vec{B} .

(From these equations, it can be seen that equatorial and low-inclination orbits will produce the largest emf's, since the maximum emf is produced when the tether velocity and the magnetic field are perpendicular to each other.)

In this Earth orbit, the emf acts to create a potential difference across the tether by making the upper end of the tether positive with respect to the lower end. The emf acts to collect electrons at the upper end and drive them down the tether to the lower end, where they are emitted when a current is allowed to flow in the tether.

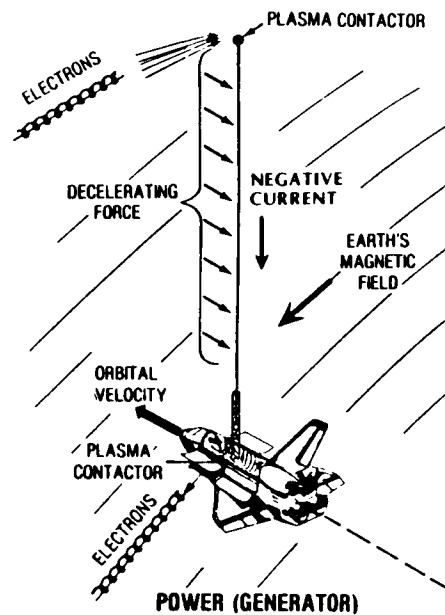

Figure 2.14. Power Generation With an Electromagnetic Tether System [derived from Figure 1 of Ref. 15]

In order to produce a current from this potential difference, the tether ends must make electrical contact with the Earth's plasma environment. Plasma contactors at the tether ends provide this contact, establishing a current loop (a so-called "phantom loop") through the tether, external plasma, and ionosphere. Although processes in the plasma and ionosphere are not clearly understood at this time, it is believed that the current path is like that shown in Figure 2.15. The collection of electrons from the plasma at the top end of the tether, and their emission from the bottom end, creates a net-positive charge cloud (or

region) at the top end, and a net-negative charge cloud at the bottom. The excess free charges are constrained to move along the geomagnetic field lines intercepted by the tether ends, until they reach the vicinity of the E region of the lower ionosphere, where there are sufficient collisions with neutral particles to allow the electrons to migrate across the field lines and complete the circuit.

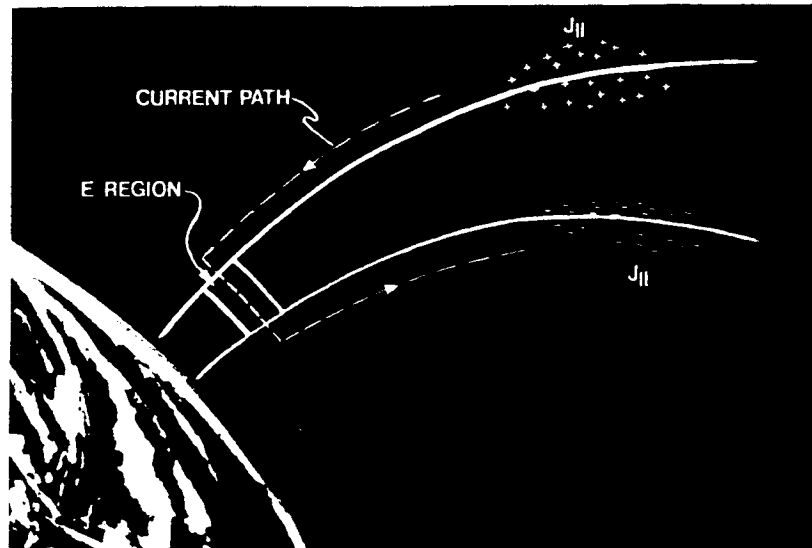

Figure 2.15. The Current Path External To An Orbiting Electromagnetic Tether System
[Ref. 5, pp. 3-59]

To optimize the ionosphere's ability to sustain a tether current, the tether current density at each end must not exceed the external ionospheric current density. Plasma contactors must effectively spread the tether current over a large enough area to reduce the current densities to the necessary levels. Three basic tether system configurations, using three types of plasma contactors, have been considered up to this point. They are: (1) a passive large-area conductor at both tether ends; (2) a passive large-area conductor at the upper end and an electron gun at the lower end; and, (3) a plasma-generating hollow cathode at both ends.

In the first configuration, as the upper plasma contactor (probably a conducting balloon) collects electrons, it utilizes its large surface area to produce a sufficiently low current density at its contact boundary with the ionosphere. The lower plasma contactor in this configuration (perhaps a conductive surface of the attached spacecraft) utilizes its large surface area in a similar way as it collects ions. However, since the electrons at the upper end have higher thermal currents, the surface area required to collect ions at the lower end for a given current is much larger. Moreover, this configuration is limited to very small currents.

To overcome this situation, it has been proposed to replace the passive large-area conductor at the lower end with an electron gun. This provides the equivalent of collecting a positive current by ejecting a negative electron current. Ejecting these electrons at a high energy distributes them over an effectively large contact region. Unfortunately, electron guns are active plasma contactors, requiring on-board electrical power to drive them.

The third configuration, known as the Plasma Motor-Generator (PMG), is quite different from the first two. Based upon research results and performance modeling up to this point, it is projected to be the most promising of the three systems. In the PMG, instead of relying on a passive and physically large conducting surface to collect currents, a hollow cathode at each tether end generates an expanding cloud of highly conductive plasma. The plasma density is very high at the tip of the tether, and falls off to ionospheric densities at a large distance from the tip. This plasma cloud provides a sufficient thermal electron density to carry the full tether current in either direction at any distance from the tether end, until it is merged into the ambient ionospheric plasma currents. This ease of current reversibility allows the PMG to function alternately as either a generator or a thruster, with greater ease than either of the other two configurations (as will be discussed in more detail in the next section). Hollow cathodes are also active plasma contactors, requiring on-board electrical power and a gas supply to operate. However, they require much less power than an

electron gun, and the gas supply should not impose a severe weight penalty. Two diagrams of a hollow cathode plasma source are shown in Figure A.23 of the Appendix. Additional diagrams and information relating to the construction and operation of the PMG hollow cathode plasma contactor are given in Figures A.24, A.25 and A.26 of the Appendix. Typical characteristics of a hollow cathode and an electron gun are compared in Figures A.27 and A.28 of the Appendix.

Although current research and modeling results indicate that hollow cathodes are far superior to electron guns and passive contactors for producing high current contact with the ionosphere, this has not been verified yet by flight tests. In addition, there may be particular applications for which passive contactors or electron guns are desirable.

Since hollow cathodes are projected to allow much larger tether currents than the other types of plasma contactors, PMG systems should obtain desired electrical power levels at lower voltages than the other tether systems, and thereby avoid requirements for technology advances to handle very high voltages. PMG systems are expected, therefore, to use shorter and more massive tethers, greatly reducing the mass required for a stabilizing end mass, and simplifying tether deployment and dynamics. Using hollow cathode plasma contactors should also be safer for spacecraft systems, since they establish a known vehicle ground reference potential with respect to the local plasma.

The current passing through the tether can be controlled by any one of several methods, depending upon the type of plasma contactors used. For systems using passive conductors at both ends, it is controlled with a variable resistance, inserted between the tether and one of the plasma contactors. For systems using an electron gun as a plasma contactor, the tether current is controlled by controlling the current emitted by the electron gun. Unfortunately, these methods are very inefficient. They not only waste all of the I^2R power lost in the resistors, plasma sheaths (around the plasma contactors), and electron gun impedance, but they also dump most of it as heat back into the spacecraft, where it is a significant thermal control and heat rejection problem.

PMG systems, on the other hand, use DC impedance matching to control the tether current and power. This is accomplished by adjusting a continuously variable effective load impedance in order to match the varying tether voltage and power with the spacecraft load power requirements. A variety of circuits can be used to do this. At the present, the most attractive circuit is a variation of a DC/DC converter, developed at NASA/Lewis Research Center as the power converter module for the "Electric Airplane" project. The conductivity of the hollow cathode assembly is not readily controllable, and it acts only as an upper limit on tether current. Tether current is variable over its full + range with little, if any, interaction with the hollow cathode assembly controller.

The basic equation of the current loop (circuit) is:

$$V_{\text{IND}} = IR + \Delta V_{\text{LOW}} + \Delta V_{\text{UP}} + \Delta V_{\text{ION}} + \Delta V_{\text{LOAD}} \quad ;$$

where V_{IND} = emf induced across the tether (volts),

I = tether current (amps),

R = resistance of the tether (ohms),

ΔV_{LOW} = voltage drop across the space charge region around the lower plasma contactor (volts),

ΔV_{UP} = voltage drop across the space charge region around the upper plasma contactor (volts),

ΔV_{ION} = voltage drop across the ionosphere (volts), and

ΔV_{LOAD} = voltage drop across a load (volts).

This equation simply states that the emf induced across the tether by its motion through the magnetic field is equal to the sum of all of the voltage drops in the circuit. The IR term in the equation is the voltage drop across the tether due to its resistance (according to Ohm's Law).

To provide an expression for the working voltage available to drive a load, this equation can be rewritten as:

$$\Delta V_{\text{LOAD}} = V_{\text{IND}} - IR - \Delta V_{\text{LOW}} - \Delta V_{\text{UP}} - \Delta V_{\text{ION}} \quad .$$

The voltage drop across the space charge region (sheath, electron gun, or plasma cloud) at each tether end is caused by the impedance of that region. The voltage drop across the ionosphere is likewise due to its impedance. The problem with these equations is that the impedances of the charge regions around the tether ends are complex, nonlinear, and unknown functions of the tether current. The impedance of the ionosphere has also not been clearly determined. Although some laboratory studies have been performed, and estimates made, detailed flight tests will have to be performed before these quantities can be clearly determined.

It has been calculated that the ionospheric impedance should be on the order of 1-20 ohms (reference 267). The highest impedances of the tether system are encountered at the space charge sheath regions around the upper and lower plasma contactors. Reducing these impedances will greatly increase the efficiency of the tether system in providing large currents. Data exist which indicate that plasmas released from hollow cathode plasma contactors should greatly reduce the sheath impedance between the contactors and the ambient plasma surrounding them. Data from one study of hollow cathodes predict Z_{LOW} (electron emitting end) to be on the order of 20 ohms, and Z_{UP} (electron collecting end) to be on the order of 10-1000 ohms (reference 9, pp. 499-546). Studies of PMG systems with hollow cathode plasma contactors, on the other hand, have indicated that there is a nearly constant voltage drop of 5-20 volts at the tether ends, independent of tether current (reference - Dr. James McCoy, NASA/Johnson Space Center). Therefore, for the PMG model, the voltage across the tether is simply reduced by 20 volts to account for the voltage drop at both tether ends. Although processes in these plasmas and in the ionosphere are not well understood and require much continued study and evaluation through testing, preliminary indications are that feasible tether and plasma-contactor systems should be able to provide large induced currents.

As indicated earlier, the electric currents induced in such tether systems can be used to power loads on board the spacecraft equipped with them. They can also be used as primary power for the spacecraft. It has been calculated that electromagnetic tether systems should be capable of

producing electrical powers in the multikilowatt to possibly the megawatt range (reference 9, pp. 161-184). Calculations for some sample systems are presented in Figures A.29 through A.32 of the Appendix.

There is a price to be paid for this electrical power, however. It is generated at the expense of spacecraft/tether orbital energy. This effect is described in detail in the next section (2.4.3).

In principle, electromagnetic tether systems can generate electrical power not only in Earth orbit, but also when they move through the magnetic fields of other planets and interplanetary space. The magnetic field in interplanetary space is provided by the solar wind, which is a magnetized plasma spiralling outward from the sun.

Applications related to this technology are presented in the "Electrodynamics" and "Planetary" categories of the "Applications" section.

References 5 (pp. 1-22 through 1-24, 3-49 through 3-65), 9 (pp. 153-184, 547-594), 25, 45, and data from Dr. James McCoy (NASA/Johnson Space Center) are the primary references for this section.

2.4.3 Thrusters

As mentioned in the previous two sections, electromagnetic tether systems can be used to generate thrust or drag. Consider the gravity-gradient-stabilized system in Earth orbit described in the first part of Section 2.4.2. Its motion through the geomagnetic field induces an emf across the tether. When the current generated by this emf is allowed to flow through the tether, a force is exerted on the current (on the tether) by the geomagnetic field (see Figure 2.16). This force is given by:

$$\vec{F} = \int_{\text{along length of tether}} (I \vec{dl}) \times \vec{B} = I \int_{\text{along length of tether}} \vec{dl} \times \vec{B} ;$$

where \vec{F} = force exerted on the tether by the magnetic field (newtons),
 I = tether current (amps),
 $d\vec{l}$ = differential element of tether length - a vector pointing in the direction of positive current flow (m), and
 \vec{B} = magnetic field strength (webers/m²).

For the special case of a straight tether, this equation simplifies to:

$$\vec{F} = I\vec{L} \times \vec{B} \quad ;$$

where \vec{L} = tether length - a vector pointing in the direction of positive current flow (m).

Using the definition of the vector cross product, this equation for the electromagnetic force on a straight tether can also be written as:

$$F = ILB \sin \theta \quad ;$$

where θ = angle between \vec{L} and \vec{B} .

Its maximum value occurs when the tether is perpendicular to the magnetic field.

Depending on the relative orientation of the magnetic field and the tether velocity, this force can have a component parallel to the velocity and one perpendicular to the velocity. Considering the parallel (in-plane) component, whenever the current induced in the tether by the magnetic field is allowed to flow, this component of the force always acts to bring the relative velocity between the tether system and the magnetic field rest frame to zero. In the case of a tether system in low Earth orbit, where the orbital velocity of the tether is greater than the rotational velocity of the geomagnetic field and they are rotating in the same direction, this force is a drag on the tether. This means that when electric power is generated by this system for on-board use, it is

generated at the expense of orbital energy. If the system is to maintain its altitude, this loss must be compensated by rockets or other propulsive means.

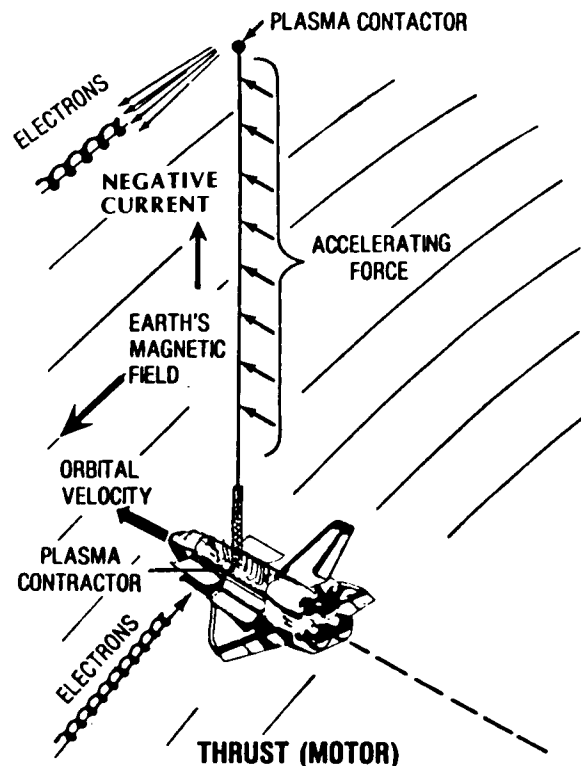

Figure 2.16. Thrust Generation With An Electromagnetic Tether System [derived from Figure 1 of Ref. 15]

When current from an on-board power supply is fed into the tether against the induced emf, the direction of this force is reversed. This force follows the same equation as before, but now the sign of the cross product is reversed, and the force becomes propulsive. In this way, the tether system can be used as a thruster. Therefore, the same tether system can be used reversibly, as either an electric generator, or as a thruster (motor). As always, however, there is a price to be paid. The propulsive force is generated at the expense of on-board electrical power.

It is necessary to distinguish between tether systems orbiting at subsynchronous altitudes, and those orbiting at altitudes greater than the synchronous altitude, where the sense of the relative velocity between the satellite and the magnetic field rest frame is reversed (often thought of in terms of a concept known as the "co-rotating field"). An analogous situation exists in orbits around Jupiter for altitudes greater than 2.2 Jovian radii from its center (the Jovian synchronous altitude: i.e., the altitude at which the rotational angular velocity of an orbiting satellite equals the rotational velocity of Jupiter and its magnetic field). Another analogous situation exists in interplanetary space if a spacecraft moves outward from the sun at less than the solar wind velocity (the solar wind moves outward at a speed of 400 km/s). In such cases, dissipation of the induced electrical current would produce a thrust (not a drag) on the tether. Again, the force acts to bring the relative velocity between the tether and the magnetic field rest frame to zero. In such cases, feeding current into the tether against the induced emf would produce a drag. When moving in a direction opposite to the direction of motion of the magnetic field, the effects would be reversed.

Systems have been proposed to operate reversibly as power and thrust generators (reference 9, pp. 161-184). Such systems could provide a number of capabilities. Calculations of the performance of a number of example systems are presented in Figures A.29 - A.32 of the Appendix.

In addition to the in-plane component, the electromagnetic force on the tether current generally also has an out-of-plane component (perpendicular to the tether velocity). For an orbiting tether system, the out-of-plane force component acts to change the orbital inclination, while doing no in-plane mechanical work on the tether, and inducing no emf to oppose the flow of current in the tether. This makes electromagnetic tethers potentially ideal for making orbital plane changes. Unlike rockets, they conserve energy during orbital plane changes. If the current is constant over a complete orbit, the net effect of this force is zero (since reversals in the force direction during the orbit cancel each other out). On the other hand, if a net orbital inclination change

is desired, it can be produced by simply reversing the tether current at points in the orbit where the out-of-plane force reverses its direction, or by allowing a tether current to flow for only part of an orbit. Attention must be paid to this out-of-plane force when operating a tether alternately as a generator and thruster, and when operating a tether system which alternately generates and stores electrical energy. Strategies for using electromagnetic tethers to change orbits are shown in Figure A.33 of the Appendix.

Electromagnetic forces also cause the tether to bow, and produce torques on the tether system. These torques cause the system to tilt away from the vertical until the torques are balanced by gravity-gradient restoring torques. These torques produce in-plane and out-of-plane librations. The natural frequencies of in-plane and out-of-plane librations are $\sqrt{3}$ times the orbital frequency and twice the orbital frequency, respectively. Selective time phasing of the $\vec{I} \times \vec{B}$ loading, or modulation of the tether current, will damp these librations. The out-of-plane librations are more difficult to damp because their frequency is twice the orbital frequency. Unless care is taken, day/night power generation/storage cycles (50/50 power cycles) can actively stimulate these librations. Careful timing of tether activities will be required to control all tether librations. The proposed PMG systems will use passive $\vec{I} \times \vec{B}$ phasing to control tether dynamics; and a long, light ballast tether will be attached to the end of the PMG tether for missions requiring more control. Additional information on electromagnetic libration control issues is shown in Figure A.34 of the Appendix.

Applications related to the tether systems described in this section are presented in the "Electrodynamics" and "Planetary" categories of the "Applications" section, as appropriate.

References 1 (pp. 30-33), 5 (pp. 1-22 through 1-24, 3-49 through 3-65), 9 (pp. 161-184), 25, and 45 are the primary references for this section.

2.4.4 ULF/ELF/VLF Antennas

As discussed in Section 2.4.2, the movement of an Earth-orbiting electromagnetic tether system through the geomagnetic field gives rise to an induced current in the tether. One side effect of this current is that, as the electrons are emitted from the tether back into the plasma, ULF, ELF, and VLF electromagnetic waves are produced in the ionosphere.

In the current loop external to the tether, electrons spiral along the geomagnetic field lines and close at a lower layer of the ionosphere (see Figure 2.17). This current loop (or so-called "phantom loop") acts as a large ULF, ELF, and VLF antenna. (The phantom loop is shown in Figure 2.18.) The electromagnetic waves generated by this loop should propagate to the Earth's surface, as shown in Figure 2.19. The tether current generating these waves can be that induced by the geomagnetic field, or one provided by a transmitter on board the spacecraft.

Messages can be transmitted by modulating the waves generated by the current loop. If the induced current is used to generate these waves, it is modulated by varying a series impedance, or by turning an electron gun or hollow cathode on the lower tether end on and off at the desired frequency. If a transmitter is used, current is injected into the tether at the desired frequency.

The ULF, ELF, VLF waves produced in the ionosphere will be injected into the magnetosphere more efficiently than those from existing ground-based, man-made sources. It is believed that the ionospheric boundary may act as a waveguide, extending the area of effective signal reception far beyond the "hot spot" (area of highest intensity reception, with an estimated diameter of about 5000 km) shown in Figure 2.19. If this turns out to be the case, these waves may provide essentially instant worldwide communications, spreading over the Earth by ducting. Calculations have been performed, predicting that power levels of the order of 1 W by night and 0.1 W by day can be injected into the Earth-ionosphere transmission

line by a 20-100 km tether with a current of the order of 10 A. Such tether systems would produce wave frequencies throughout the ULF (3-30 Hz) and ELF bands (30-300 Hz), and even into the VLF band (about 3000 Hz).

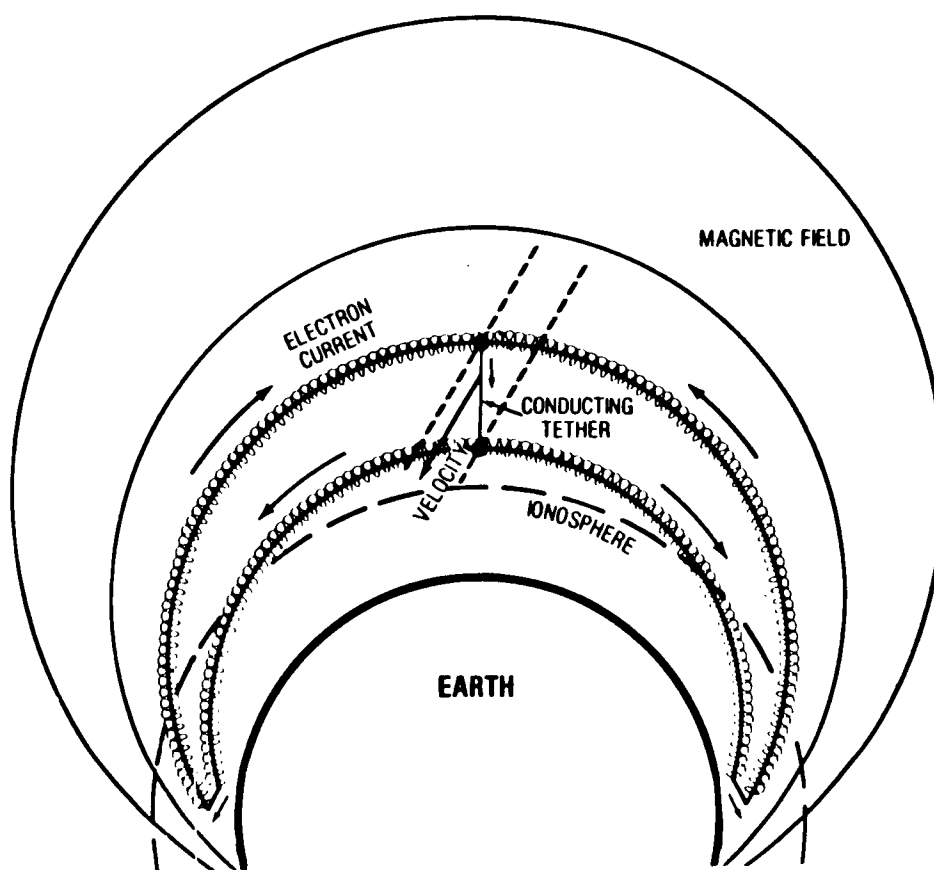

Figure 2.17. Electron Paths in the Electromagnetic Tether Generator [reference 15]

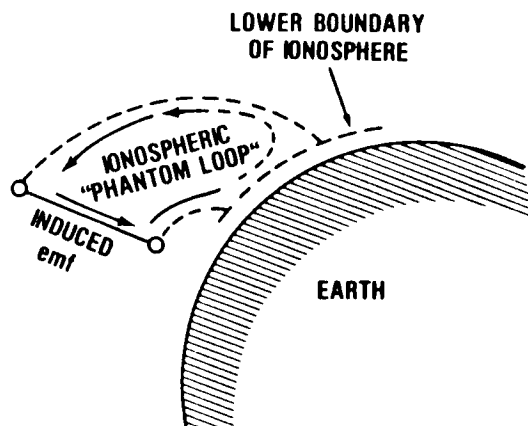

Figure 2.18. The "Phantom Loop" of the ULF/ELF Tether Antenna [reference 158]

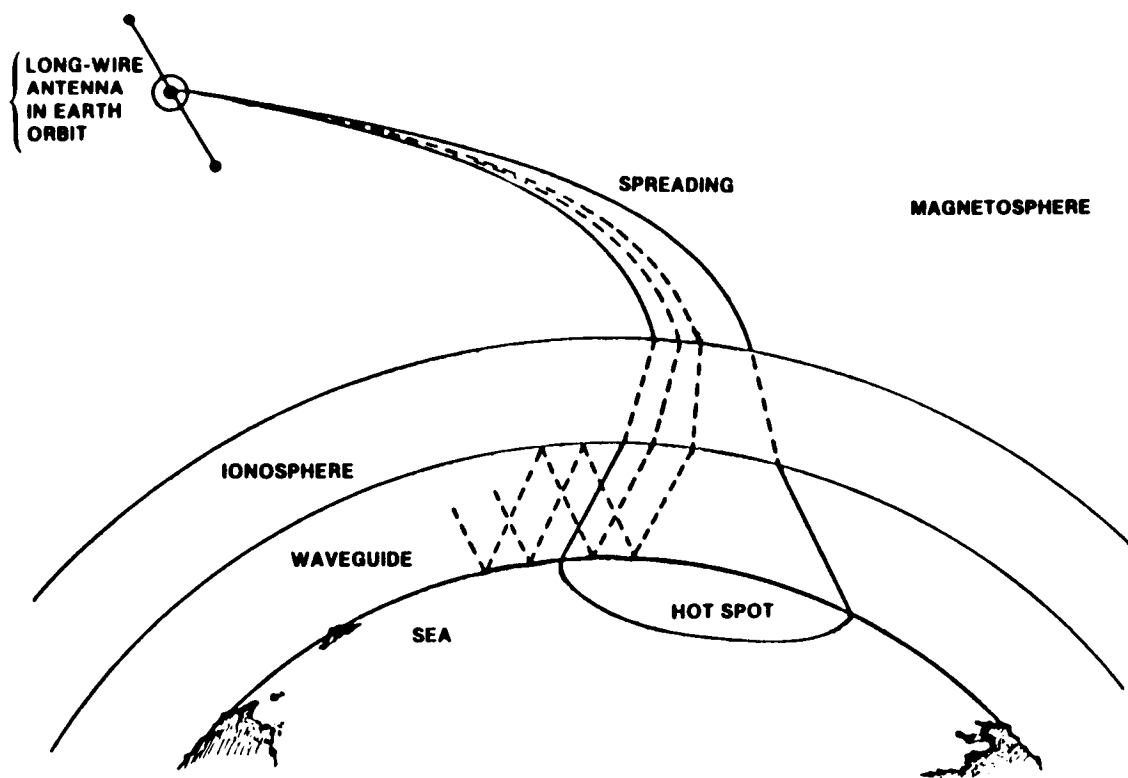

Figure 2.19. Propagation of ULF/ELF/VLF Waves To The Earth's Surface From An Orbiting Tether Antenna [reference 15]

It should be noted that if the induced tether current is used to power the antenna, orbital energy will be correspondingly decreased. A means of restoring this orbital energy (such as rocket thrust) will be required for long missions.

Applications related to this technology are presented in the "Electrodynamics" category of the "Applications" section. References 15 and 16 are the primary references for this section.

2.4.5 Constellations

As mentioned in Section 2.1.3, electromagnetic forces, exerted by the geomagnetic field on the current in orbiting tethers, can be used in conjunction with gravity-gradient forces to stabilize two-dimensional constellations (see Figure 2.9). The force exerted on a current in a tether is exactly the force described in Section 2.4.3. The tether currents used in these constellations can be those induced by the geomagnetic field, or those provided by on-board power supplies.

The basic idea is that gravity-gradient forces will provide vertical and overall attitude stability for the constellation, and electromagnetic forces will provide horizontal and shape stability. This is accomplished in the quadrangular configuration by establishing the current direction in each of the two vertical tethers such that the electromagnetic forces exerted on them are co-planar with the constellation, and push them horizontally apart. This provides stabilizing tension in the horizontal and diagonal tethers.

In the pseudo-elliptical configuration, the tether currents in the two side arcs are directed such that the electromagnetic forces on them are co-planar with the constellation, and push the side arcs horizontally away from each other. Each side arc may be composed of a number of satellites connected in series by tethers. The current directions for

the tethers in the same side arc will be the same, providing a consistent outward force. Large masses are placed at the top and bottom juncture points, where the two sides join together. This provides additional stability for the constellation.

Applications related to the electromagnetic stabilization of constellations are presented in the "Constellations" category of the "Applications" section. References 5 (p. 1-27), 10 (pp. 286-308), and 11 (pp. 150-203), are the primary references for this section.

SECTION 3
APPLICATIONS

Applications

3.1 GENERAL

This section provides a detailed summary of each tether application proposed up to this printing. In some cases, these applications are nothing more than general ideas, and in others, they are well-defined systems, based on detailed study and computational analysis. These applications have been divided into eight general categories. In cases where an application can be logically placed in more than one, it has been placed in the one considered most appropriate. In cases where an application, or its basic system concept, can be manifested in more than one configuration, each involving a significantly different design feature or size, these variations may be placed in different categories, as appropriate. To avoid redundancy, every possible variation of a particular system concept is not described separately. Instead, Section 3.3 contains a cross reference which lists each application and the categories with which it has a logical existing or potential connection. This table is intended to help the reader identify potential areas of use, which extend past the single category in which each application description appears. It should also give the reader an appreciation of the potential scope and usefulness of each application and its basic system concept. Descriptions of proposed applications follow this cross reference. For these descriptions, a standardized format is used to allow quick and easy comparisons of different applications. This format is designed to effectively serve as wide a readership as possible, and to conveniently convey the pertinent details of each application. Readers with different interests and needs can find the information and level of detail they desire at a glance.

The title of the application is presented at the top of the page, followed by its identification number and the date of its latest update. The identification number contains a two-letter abbreviation of its category, and a number indicating its position in the category. The numbering system is designed to allow the addition of new applications wherever appropriate, without disruption to the existing organization. The "Application" subsection provides a brief statement of the application, and the "Description" subsection provides a brief description of the system design and operation. A picture is located in the upper right

of the page to supplement the description, by providing a diagrammatic representation of the system and its operation. The "Characteristics" subsection exhibits the major system design and operation parameters in bullet form. The last characteristic is always a bullet entitled "Potential for Technology Demonstration." This entry is an attempt to classify both the conceptual maturity of an application, and the amount of technological development required to demonstrate the particular application. Three descriptors have been used to indicate the demonstration time-frame:

- o Near-Term: 5 years or less,
- o Mid-Term: 5-10 years, and
- o Far-Term: 10 years or greater.

The date of this printing may be assumed to be the beginning of the Near-Term period. Together, these subsections present a brief and complete summary of the system's application, design, and operation.

The "Critical Issues" subsection, which follows, lists the developmental and operational questions and issues of critical importance to the application. The "Status" subsection indicates the status of studies, designs, development, and demonstrations related to the application. The "Discussion" subsection presents more detailed information about all aspects of the application. This subsection is designed to satisfy the needs of the reader requiring more than summary information about the application. Following this, the "Contacts" subsection lists names of investigators who are involved with work related to the application, and who may be contacted for further information. (See Section 6, "Contacts", for addresses and telephone numbers.) Finally, the "References" subsection lists the reference and page numbers of the reference used in the preparation of the application description. The reference numbers refer to a complete listing, entitled "References", which can be found in Section 5, "References and Selected Bibliography."

3.2 CRITICAL ISSUES

Many of the applications that follow are subject to similar critical issues which are more or less "generic" to tethers. These are issues

such as damage from micrometeoroids or other space debris, dynamic noise induced on platforms, high power control electronics technology, rendezvous guidance and control, tether material technology development, and system integration. Many of the figures presented in the Appendix, in particular figures A.35 through A.38, deal with these issues.

3.3 TETHER APPLICATIONS INDEX AND CROSS REFERENCE

PRECEDING PAGE BLANK NOT FILMED

PAGE 3-6 INTENTIONALLY BLANK

TETHER APPLICATIONS INDEX AND CROSS REFERENCE

SCIENCE APPLICATIONS

Applic. Number	Application Title	Page	Science Applications	Electrodynamics	Transportation	Controlled Gravity	Constellations	Technology & Test	Space Station	Planetary
SA.01.00	Science Applications Tethered Platform	3-19	●	●		●	●	●	●	
SA.02.00	Shuttle Science Applications Platform	3-21	●	●		●	●	●		
SA.03.00	Spacecraft Array for Michelson Spatial Interferometry	3-23	●				●			
SA.04.00	Gravity Wave Detection Using Tethers	3-25	●							
SA.05.00	Tethered Satellite for Cosmic Dust Collection	3-27	●							●

TETHER APPLICATIONS INDEX AND CROSS REFERENCE

ELECTRODYNAMICS APPLICATIONS

Applic. Number	Application Title	Page	Science & Applications	Electrodynamics	Transportation	Controlled Gravity	Constellations	Technology & Test	Space Station	Planetary
EL.01.00	Electromagnetic Generator	3-29		●	●				●	●
EL.02.00	Electromagnetic Thruster	3-33		●	●				●	●
EL.03.00	Electromagnetic Motor/Generator for Power Storage	3-35		●					●	●
EL.04.00	Electromagnetic Thruster to Offset Drag	3-37		●	●				●	●
EL.05.00	ULF/ELF/VLF Communications Antenna	3-39	●	●				●	●	

TETHER APPLICATIONS INDEX AND CROSS REFERENCE

TRANSPORTATION APPLICATIONS

Applic. Number	Application Title	Page	Science Applications	Electrodynamics	Transportation	Controlled Gravity	Constellations	Technology & Test	Space Station	Planetary
TR.01.00	Satellite Boost from Orbiter	3-41			●					
TR.02.00	Upper Stage Boost from Orbiter	3-43			●					
TR.03.00	Shuttle External Tank Deorbit	3-45			●					
TR.04.00	Shuttle Docking by Tether	3-47			●				●	
TR.05.00	Generalized Momentum Scavenging From Spent Stages	3-49			●		●		●	
TR.06.00	Tethered Sail (Hypersonic Rudder)	3-51			●					
TR.07.00	Internal Forces for Orbital Modification (Orbital Pumping)	3-53			●					●
TR.08.00	Tether Reboosting of Decaying Satellites	3-55			●				●	
TR.09.00	Tether Rendezvous System	3-57			●		●		●	●
TR.10.00	Space Elevator to Geosynchronous Earth Orbit	3-59			●					
TR.11.00	Small Expendable Deployer System	3-61			●					
TR.12.00	Multipass Aerobraking of Planetary Probe	3-63			●					●
TR.13.00	Tether Released Recovery System	3-65	●		●				●	

TETHER APPLICATIONS INDEX AND CROSS REFERENCE

CONTROLLED GRAVITY APPLICATIONS

Applic. Number	Application Title	Page	Science & Applications	Electrodynamics	Transportation	Controlled Gravity	Constellations	Technology & Test	Space Station	Planetary
CG.01.00	Rotating Controlled-Gravity Laboratory (Tethered Platform)	3-67	●			●	●	●		●
CG.02.00	Rotating Controlled-Gravity Laboratory (Tether-Enhanced Station)	3-69	●			●	●	●		●

TETHER APPLICATIONS INDEX AND CROSS REFERENCE

CONSTELLATIONS APPLICATIONS

Applic. Number	Application Title	Page	Science Applications	Electrodynamics	Transportation	Controlled Gravity	Constellations	Technology & Test	Space Station	Planetary
CO.01.00	Vertical Tethered Constellation at GEO	3-71	●		●	●	●			●
CO.02.00	Combination of Free Flyers and Tethered Constellations	3-73	●		●	●	●			●
CO.03.00	Tether Structures with Trusses	3-75			●		●	●	●	
CO.04.00	External Tank Based Structures	3-77	●		●	●	●		●	
CO.05.00	Compressive Tethers	3-79	●		●	●	●	●	●	
CO.06.00	Multiprobe for Atmospheric Studies	3-81	●				●	●	●	
CO.07.00	Space Station Tethered Platform with Controlled Gravity Lab	3-83	●			●	●	●	●	
CO.08.00	Space Station Center of Mass Mgmt. with a Tethered Platform	3-85	●			●	●	●	●	
CO.09.00	1-D Drag Stabilized Constellation	3-87	●				●	●	●	
CO.10.00	2-D "Fish Bone" Constellation	3-89	●				●	●	●	
CO.11.00	2-D Drag Stabilized Constellation (Rectangular)	3-91	●				●	●	●	
CO.12.00	2-D Drag Stabilized Constellation (Triangular)	3-93	●				●	●	●	
CO.13.00	2-D Electro-dynamically Stabilized Constellation	3-95	●	●			●	●	●	
CO.14.00	2-D Pseudo-Elliptical Electro-magnetically Stabilized Const.	3-97	●	●			●		●	
CO.15.00	Torquing of a Spinning Station for Spin-Axis Precession Rate Control	3-99	●		●	●	●		●	

TETHER APPLICATIONS INDEX AND CROSS REFERENCE

TECHNOLOGY AND TEST APPLICATIONS

Applic. Number	Application Title	Page	Science & Applications	Electrodynamics	Transportation	Controlled Gravity	Constellations	Technology & Test	Space Station	Planetary
TT.01.00	Shuttle Tethered Aerothermodynamic Research Facility	3-101	●					●		
TT.02.00	Shuttle Continuous Open Wind Tunnel	3-103	●					●		

TETHER APPLICATIONS INDEX AND CROSS REFERENCE

SPACE STATION APPLICATIONS

Applic. Number	Application Title	Page	Science & Applications	Electrodynamics	Transportation	Controlled Gravity	Constellations	Technology & Test	Space Station	Planetary
SS.01.00	Tethered Orbital Refueling Facility	3-105				●			●	
SS.02.00	Tethered OTV Hangar/Depot	3-109				●			●	
SS.03.00	Microgravity Laboratory	3-111	●			●	●	●	●	
SS.04.00	Variable/Low Gravity Laboratory	3-113	●			●	●	●	●	
SS.05.00	Tethered Space Elevator	3-115	●		●	●		●	●	
SS.06.00	Shuttle Deorbit From Space Station	3-117			●				●	
SS.07.00	Tethered OTV Launch	3-119			●				●	

TETHER APPLICATIONS INDEX AND CROSS REFERENCE

ORIGINAL PAGE IS
OF POOR QUALITY

PLANETARY APPLICATIONS

Applic. Number	Application Title	Page	Science & Applications	Electrodynamics	Transportation	Controlled Gravity	Constellations	Technology & Test	Space Station	Planetary
PA.01.00	Heliocentric Alfvén Engine for Interplanetary Transportation	3-121		●	●					●
PA.02.00	Electromagnetic Deceleration for Planetary Capture	3-123		●	●					●
PA.03.00	Jupiter Inner Magnetosphere Maneuvering Vehicle	3-125		●	●					●
PA.04.00	Tethered Lunar Satellite for Remote Sensing	3-127	●							●
PA.05.00	Lunar Equator Surface Sling	3-129			●					●
PA.06.00	Earth-Moon Tether Transport System	3-131			●					●
PA.07.00	Mars Aeronomy Observer	3-133	●							●
PA.08.00	Asteroid Gravity Assist for Mars Missions	3-135			●					●
PA.09.00	Artificial Gravity for Earth-Mars Transfer Vehicle	3-137				●				●
PA.10.00	Mars Surface/Escape Tether Transportation System	3-139			●					●
PA.11.00	Comet/Asteroid Sample Return	3-141	●							●
PA.12.00	Main Belt Asteroid Tour and Sample Return	3-143	●		●					●
PA.13.00	Tethered Subsatellite Study of Saturn's Rings	3-145	●							●
PA.14.00	Anchored Lunar Satellite for Transportation	3-147			●					●
PA.15.00	Anchored Lunar Satellite for Communication	3-151								●

3.4. TETHER APPLICATIONS

**SCIENCE AND APPLICATIONS TETHERED PLATFORM
SA.01.00/AUGUST 1986**

APPLICATION: Provides a remote platform to the Space Station for Space and Earth observation purposes.

DESCRIPTION: A platform, attached to the Space Station by a multi-function tether (power link, data link), provides a new means to allow high precision pointing performance by the combination of disturbance attenuation via tether and active control of a movable attachment point.

CHARACTERISTICS:

- o LENGTH: 10 km
- o MASS: 10,000 kg
- o POWER REQUIRED: Up to 20 kW by tether power line link
- o LINK DATA RATE: Up to 20 Mb/s by tether optical fibers link
- o POINTING ACCURACY: Up to 10 Arcseconds
- o POTENTIAL FOR TECHNOLOGY DEMONSTRATION: Mid-Term

CRITICAL ISSUES:

- o Space Station impacts
- o Dynamic noise induced on tether
- o Movable attachment point control
- o Power link technology
- o Optical fibers link technology
- o Tether impact protection technology

STATUS:

- o PSN/AERITALIA SATP Definition Study in initial design assessment phase, mid-term report issued in March 1986. Final Report for the current study phase is expected in October 1986
- o Ball Aerospace, Selected Tether Applications Study Phase III

DISCUSSION: A tethered pointing platform would take advantage of the facilities of the station for maintenance and repair while being isolated from contamination and mechanical disturbances. As an initial step, a medium size pointing platform seems the most suitable facility for a class of observational applications. In fact, if ambitious astrophysical projects justify the design of a dedicated complex free-flyer, medium observational applications of relatively short duration could take advantage of a standard pointing facility able to arrange at different times several observational instruments.

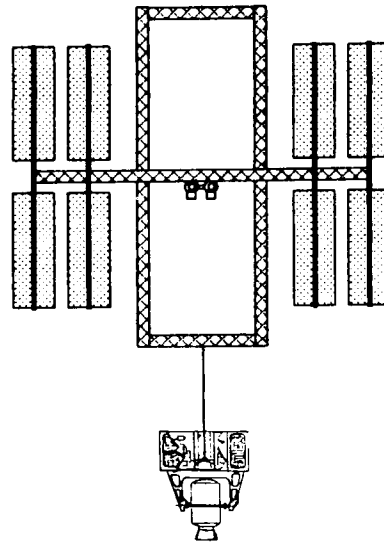

This pointing facility could allow reduction of costs, avoiding the cost of separate service functions for each application.

CONTACTS:

- o Franco Bevilacqua
- o James K. Harrison

REFERENCES: 10; 17; 18; 19; 21; 24

**SHUTTLE SCIENCE APPLICATIONS PLATFORM
SA.02.00/AUGUST 1986**

APPLICATION: Provides a remote platform to the Space Shuttle for various science and applications purposes.

DESCRIPTION: A platform, attached to the Space Shuttle by a tether, provides a unique means by which remote applications may be performed.

CHARACTERISTICS:

- o PHYSICAL CHARACTERISTICS: Not yet determined
- o POTENTIAL FOR TECHNOLOGY DEMONSTRATION: Near-Term

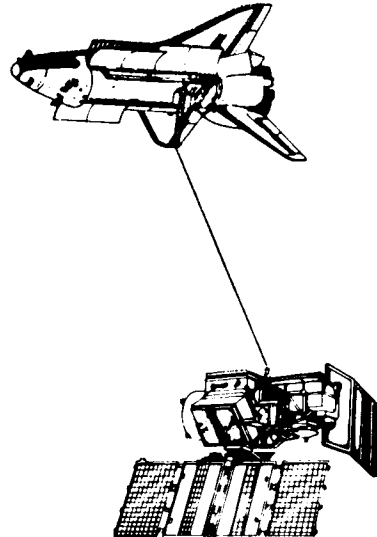

CRITICAL ISSUES:

- o Dynamic noise induced on tether
- o Micrometeoroid damage

STATUS:

- o Various investigators (listed below) have examined preliminary concepts

DISCUSSION: Possible uses for a remote platform include stereoscopic sensing, magnetometry, atmospheric science experiments, and chemical release experiments. Figure A.40 of the Appendix contains a more complete list of science applications that a tethered platform could perform.

CONTACTS:

- o Sergio Vetrella
- o Antonio Moccia
- o Franco Mariani

REFERENCES: 9

ORIGINAL PAGE IS
OF POOR QUALITY

SPACECRAFT ARRAY FOR MICHELSON SPATIAL INTERFEROMETRY
SA.03.00/AUGUST 1986

APPLICATION: Interferometric combination of the beams from 2 spiraling telescopes permits synthesis of a much larger "phantom" telescope having a resolving power equivalent to that of a single instrument with optics as large as the spiral.

DESCRIPTION: Two tether-connected spacecraft collect light from the same astronomical source and relay it to a third spacecraft housing an interferometer. The two light gathering spacecraft move in a spiral having a diameter of hundreds or thousands of meters.

CHARACTERISTICS:

- o LENGTH: 0.1 - 10 km
- o MASS: (~3 spacecraft,
3 tethers)
- o POTENTIAL FOR
TECHNOLOGY
DEMONSTRATION: Mid-Term

CRITICAL ISSUES:

- o Ultra-high-precision relative positioning of the spacecraft is required

STATUS:

- o Under study for 5 years by SAO
- o Europe has nearly identical, but independent study ongoing

DISCUSSION: Earlier studies did not utilize tethers, but rather thrusters to control velocity. Since the basic motion is a spiral, addition of tethers could greatly reduce fuel usage. All major technological problems associated with this system seem to be within reach of existing or soon-to-be developed systems. Ground-based optical interferometry, in general, has gained growing interest among the astronomical community with strong prospects for support of a space effort.

CONTACTS:

- o R. Stachnik
- o Daniel Gezari

REFERENCES: 16; 43

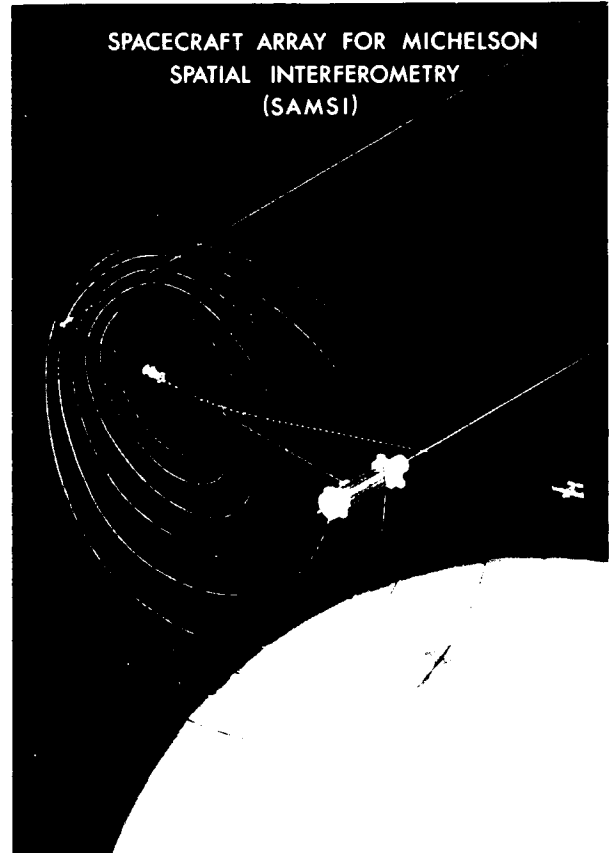

PRECEDING PAGE BLANK NOT FILMED

GRAVITY WAVE DETECTION USING TETHERS
SA.04.00/AUGUST 1986

APPLICATION: To detect gravity waves from sources such as binary stars, pulsars, and supernovae.

DESCRIPTION: The system would consist of two masses on each end of a long tether with a spring at its center. As this tether system orbits the Earth, gravitational waves would cause the masses to oscillate. This motion would be transmitted to the spring, which would be monitored by a sensing device. Analysis of the spring displacement and frequency could then lead to the detection of gravity waves.

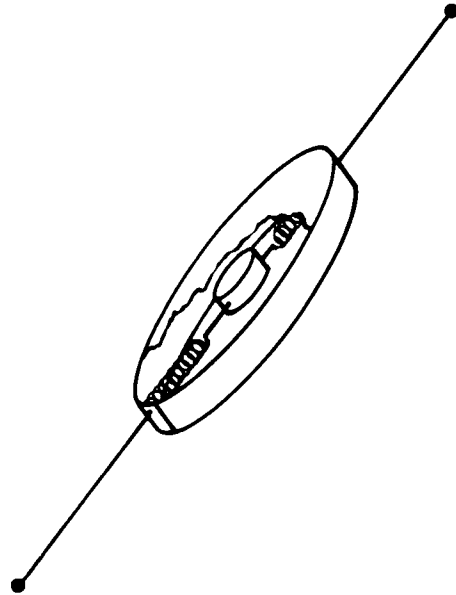

CHARACTERISTICS:

- o MASS: 20 kg (each end mass)
- o TETHER LENGTH: 25 km
- o TETHER DIAMETER: 0.6 mm
- o SPRING CONSTANT: $K_s = 2.3 \times 10^3$ dyne/cm
- o ORBIT ALTITUDE: ≥ 1000 km
- o POTENTIAL FOR TECHNOLOGY DEMONSTRATION: Near-Term

CRITICAL ISSUES:

- o Existence of gravity waves
- o Gravity wave noise level from other bodies
- o Excitation of oscillations from other sources

STATUS:

- o Preliminary calculations have been performed at SAO, Caltech, Moscow State University

DISCUSSION: This gravitational wave detector would operate in the 10 MHz - 100 MHz frequency band that is inaccessible to Earth-based detectors because of seismic noise. If gravitational waves do exist in this region, a simple system such as a tether-spring detector would prove of great value.

CONTACTS:

- o K. Thorne
- o Marino Dobrowolny

REFERENCES: 41; 42

PRECEDING PAGE BLANK NOT FILMED

TETHERED SATELLITE FOR COSMIC DUST COLLECTION
SA.05.00/AUGUST 1986

APPLICATION: To collect micro-meteoritic material from the upper-atmosphere.

DESCRIPTION: A satellite tethered to the Space Shuttle is lowered into the upper atmosphere. The surface of the satellite contains numerous small collecting elements which would document the impact of cosmic dust or actually retain the particles for analysis back on Earth.

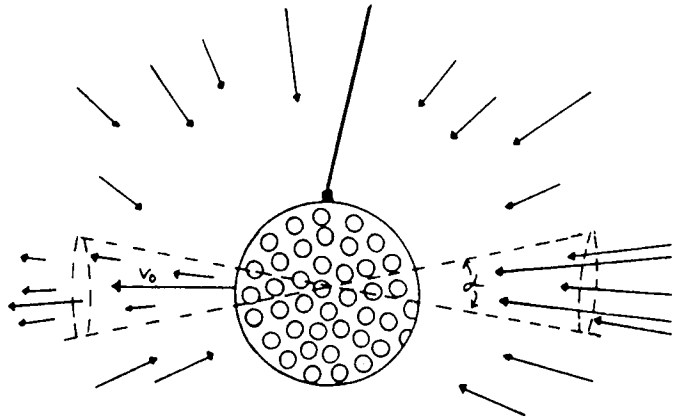

CHARACTERISTICS:

- | | |
|--|---|
| o TETHER LENGTH: 100 km | o POTENTIAL FOR TECHNOLOGY DEMONSTRATION: Near-Term |
| o OPERATING ALTITUDE: 120 km | |
| o TETHER DIAMETER: 1 meter | |
| o POWER REQUIREMENTS: Minimal, enough to operate solenoid activated irises over collectors | |

CRITICAL ISSUES:

- o Efficient analysis of large collector surface areas to detect micron-sized particles and impact craters

STATUS:

- o Preliminary concept design investigated at Indiana University Northwest

DISCUSSION: This concept proposes to collect intact cosmic dust particles smaller than 2 microns which impact the collector surface at velocities less than 3 km/sec, and the study of impact craters and impact debris which result from impacts of all sized particles at velocities greater than 3 km/sec. It is estimated that at 120 km altitude, between 1×10^3 and 1×10^4 particles will survive collection intact per square meter per day, and between 2×10^4 and 2×10^5 impact craters will be recorded per square meter per day. The figure in the illustration above represents the "survivable" impact cones for particles striking a tethered satellite. For a maximum impact velocity of 3 km/sec, α is approximately 22 degrees.

CONTACTS:

- o George J. Corso

REFERENCES: 44

PAGE 3-26 INTENTIONALLY BLANK

ELECTROMAGNETIC GENERATOR EL.01.00/AUGUST 1986

APPLICATION: Generation of DC electrical power to supply primary power to on-board loads.

DESCRIPTION: An insulated conducting tether connected to a spacecraft and possibly terminated with a subsatellite. Plasma contactors are used at both tether ends. Motion through the geomagnetic field induces a voltage across the orbiting tether. DC electrical power is generated at the expense of spacecraft/tether orbital energy.

CHARACTERISTICS:

- | | |
|---|---|
| <ul style="list-style-type: none"> o POWER PRODUCED: 1 kW - 1 MW o LENGTH: 10-20 km o MASS: 900-19,000 kg o EFFICIENCY: ~90% o MATERIALS: Aluminum/
Teflon | <ul style="list-style-type: none"> o POTENTIAL FOR TECHNOLOGY DEMONSTRATION: Near-Term |
|---|---|

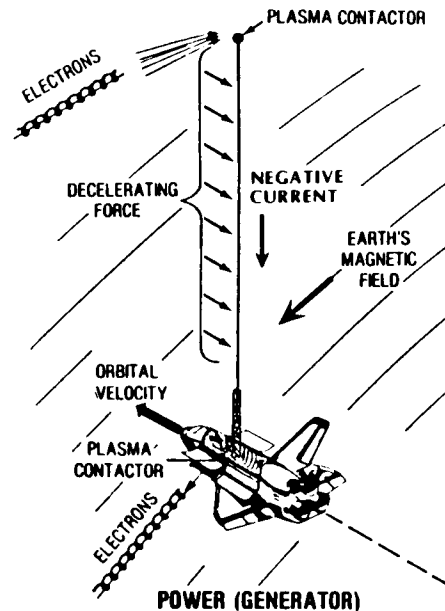

CRITICAL ISSUES:

- o Determination of the current-voltage characteristics of plasma contactor devices operating at tether currents (up to 50 A) in the ionosphere, and related instabilities
- o Characterization of the magnetospheric current closure path and its losses
- o Characterization of the effects of large electromagnetic tether systems on the LEO environment and other space vehicles
- o Assurance of long-term insulator life
- o Understanding of current collection effects at insulator defects and their impacts on system performance
- o Characterization of massive tether dynamics
- o Development of space compatible insulation methods and power processing electronics for multikilovolt operation
- o Susceptibility to micrometeoroid/debris damage

STATUS:

- o TSS-1, demonstrating electromagnetic applications, is scheduled for a 1988-89 launch
- o A demonstration of basic electromagnetic tether operation, using a small PMG system (a 200 m wire with plasma contactors), is expected to fly aboard the Shuttle as a GAS canister for James McCoy at the earliest practical date
- o A wide variety of work is actively underway in the areas of electromagnetic demonstrations, hollow cathodes, tether materials, and hardware technologies

PRECEDING PAGE BLANK NOT FILMED



DISCUSSION: An orbiting insulated conducting tether, terminated at the ends by plasma contactors, can be used reversibly as an electrical power or thrust generator. Motion through the geomagnetic field induces a voltage in the tether, proportional to its length and derived from the $\vec{v} \times \vec{B}$ electric field and its force on charges in the tether. This results in a useful DC electrical current.

Three basic plasma contactor configurations have been considered: (1) a passive large-area conductor at both tether ends; (2) a passive large-area conductor at the upper end and an electron gun at the lower end; and (3) a plasma-generating hollow cathode at both ends. Plasma Motor/Generator (PMG) systems use the hollow cathode configuration. Although not yet confirmed by flight testing, for primary power applications, PMG systems appear superior, allowing the use of shorter and more massive tethers (requiring no appreciable satellite at the end), operating at much lower voltages and higher currents. Hollow cathodes should be safer for spacecraft systems, since they establish a known vehicle ground reference potential with respect to the local plasma. They also allow simple reversibility of the tether current for switching between power and thrust generation. However, if flight tests show that the PMG design is not feasible, one or both of the other two system configurations would be alternatives. Moreover, there may be specific missions which would be served best by the characteristics of one of these two alternative configurations.

Calculations have been made of the performance of four PMG reference systems. A 2 kW system (designed with minimum mass and size for disposable tether applications) uses 10 km of #12 wire, has a mass of 200 kg, and has an efficiency of 80% (efficiency is traded for low mass and greater flexibility). A 20 kW PMG (normally operating at 2 kV and 10 A, and capable of a peak power of 125 kW) uses 10 km of #2 wire, has a mass of 1,200 kg, and has an overall efficiency of about 90%. A 200 kW PMG (normally operating at 4 kV and 50 A, and capable of a peak power of 500 kW) uses 20 km of #00 wire, has a mass of 4,200 kg, and has an overall efficiency of about 87%. A Megawatt Reference System (normally operating at 500 kW, 4 kV and 125 A; and capable of a peak power of over 2 MW) uses wire 2 cm in diameter, has a mass of 19,000 kg, and has an overall efficiency exceeding 90%. More detailed data on the 20 kW, 200 kW, and Megawatt Reference Systems are given in Figures A.29, A.30, and A.31 of the Appendix, respectively. Three other PMG systems are also described in Figure A.32 of the Appendix. All of these reference systems use aluminum wire and Teflon insulation. Aluminum is used because its conductivity per mass is about twice that of copper, and Teflon because it provides good resistance to atomic oxygen erosion. Both are mature technologies with extensive experience and standards from use on aircraft.

Electromagnetic tethers show great promise for power generation. They may find use on the Shuttle, Space Station, and planetary missions. Recommendations were made at the Venice Tether Workshop (October 1985) to use electromagnetic tethers in the 1-20 kW range to provide contingency power for the Space Station, and in higher power ranges (up

to about 1 MW) for short-term high power applications on the Space Station and other large space systems. Design tradeoffs were also recommended, including:

- o Use of multiple parallel tethers instead of long single tethers
- o Use of counterbalancing tethers deployed in opposite directions to provide center-of-mass-location control
- o Use of shorter tethers operating at low voltage and high current versus longer tethers operating at high voltage and low current
- o Definition of electrical/electronic interface between the tether and the user bus.

CONTACTS:

- o James McCoy
- o Marino Dobrowolny
- o Joseph Kolecki
- o Georg Von Tiesenhausen
- o Paul Siemers

REFERENCES: 5 (pp. 1-17 through 1-30, 3-49 through 3-65, 4-11 through 4-22); 6 (pp. 5-11 through 5-29); 9 (pp. 153-184, 369-377, 383-394, 547-594); 45; 40 (pp. 141-180)

**ELECTROMAGNETIC THRUSTER
EL.02.00/AUGUST 1986**

APPLICATION: Generation of electromagnetic propulsive thrust to boost the orbit of a spacecraft.

DESCRIPTION: An insulated conducting tether connected to a spacecraft and possibly terminated with a subsatellite. Plasma contactors are used at both tether ends. Current from an on-board power supply is fed into the tether against the emf induced in it by the geomagnetic field, producing a propulsive force on the spacecraft/tether system. The propulsive force is generated at the expense of primary on-board electric power.

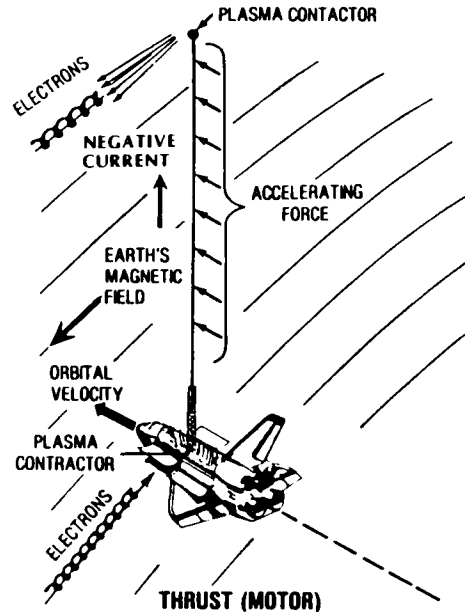

CHARACTERISTICS:

- | | |
|--------------------------------------|------------------------------|
| o THRUST PRODUCED: Up to 200 N | o MATERIALS: Aluminum/Teflon |
| o POWER REQUIRED: Up to 1.6 MW | o POTENTIAL FOR TECHNOLOGY |
| o LENGTH: 10-20 km | o DEMONSTRATION: Near-Term |
| o MASS: 100-20,000 kg & power supply | |
| o EFFICIENCY: ~90% | |

CRITICAL ISSUES:

- o The same as listed in Application EL.01.00

STATUS:

- o The same as listed in Application EL.01.00

DISCUSSION: An insulated conducting tether, terminated at the ends by plasma contactors, can be used reversibly as an electromagnetic thruster or electrical power generator. A propulsive force of $IL \times B$ is generated on the spacecraft/tether system when current from an on-board power supply is fed into the tether against the emf induced in it by the geomagnetic field.

The Plasma Motor/Generator (PMG) systems discussed in Application EL.01.00 (the "Electromagnetic Generator") also appear to be the most suitable design currently available for electromagnetic thrusters. Although projections of their performance have not yet been confirmed by flight testing, their projected high current capacity and ease of current reversibility make them good candidates for electromagnetic thruster systems. However, if flight tests show that the PMG design is not feasible, one or both of the other two system configurations dis-

cussed in Application EL.01.00 would be alternatives. Moreover, there may be specific missions which would be served best by the characteristics of one of these two alternative configurations.

Calculations have been made of the thruster performance available from the four PMG reference systems described in Application EL.01.00. The 2 kW, 20 kW, 200 kW, and Megawatt (when operated at 1 MW) PMG systems have nominal thrust ratings of 0.25 N, 2.5 N, 25 N, and 125 N, respectively. When operated at their rated peak powers, the 20 kW, 200 kW, and 1 MW PMG's operate at 125 kW, 500 kW, and greater than 2 MW, respectively; producing thrusts of greater than 40 N, 100 N, and 400 N, respectively. More detailed data on the 20 kW, 200 kW, and Megawatt Reference Systems are given in Figures A.29, A.30, and A.31 of the Appendix, respectively.

A major application of electromagnetic propulsion would be for orbital maneuvering. A 2,000 kg PMG system, using a 20 km tether of #2 AWG aluminum wire, has been calculated to produce 10 N of thrust from an 80 kW power supply. Continuous application of this thrust could produce altitude changes of 7, 30, and 150 km/day for the Space Station (200,000 kg), a space platform (50,000 kg), and a free-flyer (10,000 kg), respectively. An orbital plane change of 30 degrees in 6 months may be possible with this system. A PMG the size of the Megawatt Reference System could produce 200 N of thrust from a 1.6 MW power supply. These and other systems are described in Figure A.32 of the Appendix.

Recommendations were made at the Venice Tether Workshop (October 1985) to use 1-20 kW tethers to provide drag compensation and orbital maneuvering capability for the Space Station, other solar array powered satellites, and the power extension package (PEP), and to use higher-power tethers (up to about 1 MW) for orbital maneuvering of the Space Station and other large space systems. Design tradeoffs were also recommended, including:

- o Use of multiple parallel tethers instead of long single tethers
- o Use of counterbalancing tethers deployed in opposite directions to provide center-of-mass-location control
- o Use of shorter tethers operating at low voltage and high current versus longer tethers operating at high voltage and low current
- o Definition of electrical/electronic interface between the tether and the user bus.

CONTACTS:

- o James McCoy
- o Marino Dobrowolny
- o Joseph Kolecki
- o Georg Von Tiesenhausen
- o Paul Siemers

REFERENCES: 5 (pp. 1-17 through 1-30, 3-49 through 3-65, 4-11 through 4-22); 6 (pp. 5-11 through 5-29); 9 (pp. 161-184, 369-377, 383-394, 547-594); 13 (pp. 44-50); 40 (pp. 141-180); 45; Application EL.01.00

**ELECTROMAGNETIC MOTOR/GENERATOR FOR POWER STORAGE
EL.03.00/AUGUST 1986**

APPLICATION: Reduction in battery use for energy storage by generating thrust during the daytime and DC electricity at night with a reversible conducting tether system.

DESCRIPTION: An insulated conducting tether connected to a spacecraft equipped with a solar array. Plasma contactors are used at both tether ends. During illumination, current from the solar array is fed into the tether against the emf induced in it by the geomagnetic field, producing a propulsive force on the spacecraft/tether system. During periods of darkness, DC electrical current (induced in the tether by the geomagnetic field) is tapped for on-board use. This system stores some of the electrical energy, generated by the solar array during illumination, as orbital mechanical energy, and converts it back from orbital to electrical energy when the array is in darkness.

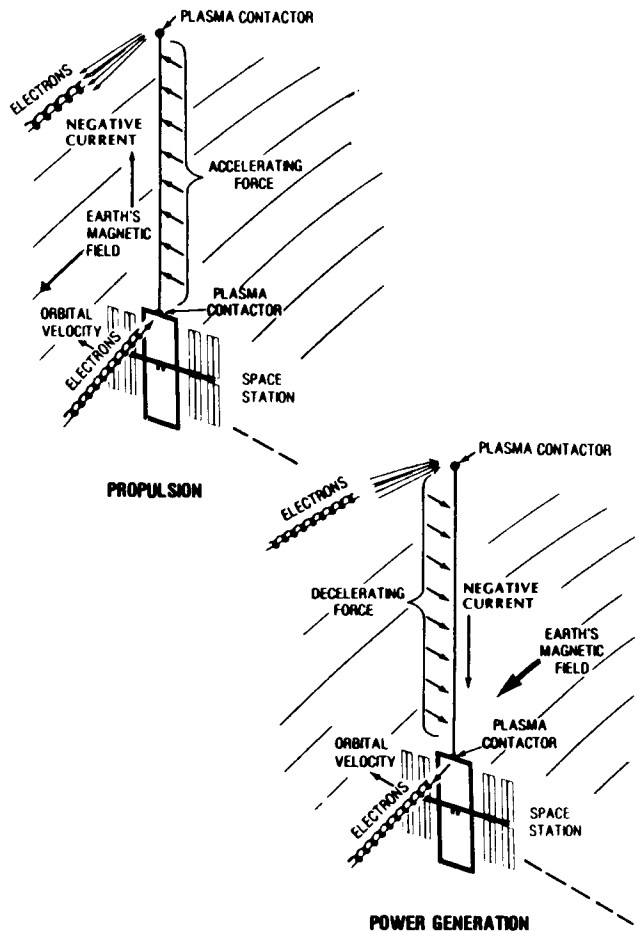

CHARACTERISTICS:

- | | | | |
|-----------------------------|--|---|----------|
| o THRUST PRODUCED: | 7.5 N | o REDUCTION IN SOLAR ARRAY SIZE: | 10% |
| o POWER REQUIRED: | 60 kW | o REDUCTION IN HEAT REJECTION: | 60% |
| o POWER GENERATED: | 100 kW | o POTENTIAL FOR TECHNOLOGY DEMONSTRATION: | Mid-Term |
| o LENGTH: | 10 km | | |
| o MASS: | 2,000 kg | | |
| o EFFICIENCY: | ~80% (Full Cycle) | | |
| o SYSTEM WEIGHT COMPARISON: | 40% of Conventional Array with Batteries | | |

CRITICAL ISSUES:

- o The same as listed in Application EL.01.00

STATUS:

- o The same as listed in Application EL.01.00

DISCUSSION: A propulsive force of $\vec{I} \times \vec{B}$ is generated on the spacecraft/tether system when current from the on-board solar array power system is fed into the tether against the emf induced in it by the geomagnetic field. This thrust boosts the orbital altitude during array

illumination. During periods of darkness, the orbital altitude is reduced as the geomagnetic field induces a voltage in the tether (proportional to its length and derived from the $\vec{v} \times \vec{B}$ electric field and its force on charges in the tether), providing useful DC electrical power.

Such a reversible energy storage system has a higher theoretical efficiency than a system employing the charging and discharging of batteries. A system comprised of a 100 kW solar array and a 2,000 kg reversible Plasma Motor/Generator (PMG) tether system could produce thrust from 60 kW during the day, and 100 kW of electrical power during the night. This system would have 40% of the weight of a conventional array with batteries. It would also provide a reduction of 10% in array size, and 60% in power-processing heat rejection. This system is described in Figure A.32 of the Appendix.

At the Venice Tether Workshop (October 1985), high-power tethers (up to about 1 MW) were recommended for a Space Station power storage system. This concept could also be applied to any other spacecraft using a solar array power system.

CONTACTS:

o James McCoy

REFERENCES: 9 (pp. 161-184, 369-377); Applications EL.01.00 and EL.02.00

**ELECTROMAGNETIC THRUSTER TO OFFSET DRAG
EL.04.00/AUGUST 1986**

APPLICATION: Generation of sufficient electromagnetic thrust to offset the orbital drag of a spacecraft.

DESCRIPTION: An insulated conducting tether connected to a spacecraft and powered by an on-board solar array. Plasma contactors are used at both tether ends. During periods of illumination, current from the solar array is fed into the tether against the emf induced in it by the geomagnetic field, producing a propulsive force on the spacecraft/tether system. This force, sufficient to offset the orbital drag, is generated at the expense of on-board electrical power from the solar array power system.

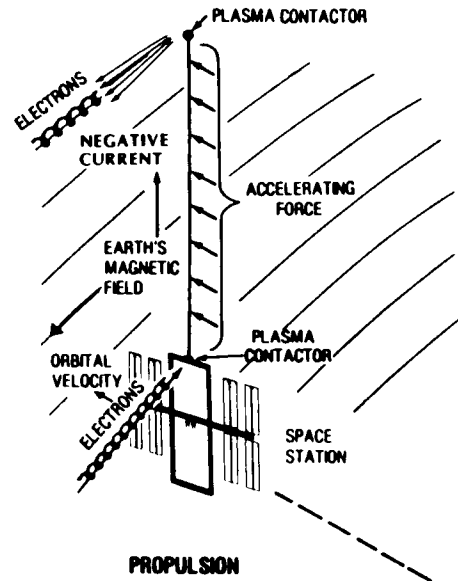

CHARACTERISTICS:

- | | |
|-----------------------------|-------------------------------------|
| o THRUST PRODUCED: 0.1-2 N | o FUEL SAVINGS: >1,000 kg/yr per kW |
| o POWER REQUIRED: 0.8-15 kW | o MATERIALS: Aluminum/Teflon |
| o LENGTH: 10 km | o POTENTIAL FOR TECHNOLOGY |
| o MASS: 100-200 kg | o DEMONSTRATION: Mid-Term |
| o EFFICIENCY: ~90% | |

CRITICAL ISSUES:

- o Successful operation of hollow cathodes or related active collectors as plasma contactors
- o Assurance of long-term insulator life
- o Susceptibility to micrometeoroid/debris damage

STATUS:

- o TSS-1, demonstrating electromagnetic applications, is scheduled for a 1988-89 launch

DISCUSSION: A propulsive force of $\vec{I} \times \vec{B}$ is generated on the spacecraft/tether system when current from the on-board solar array power system is fed into the tether against the emf induced in it by the geomagnetic field. A thrust sufficient to offset orbital drag can be generated by a small tether system. The advantage of such an arrangement is the savings in fuel no longer required to keep the spacecraft in orbit. The savings is especially significant for low earth orbits and large spacecraft with high drag. A kilowatt of power thusly used is roughly equivalent to a ton per year of fuel expended for orbit maintenance.

A 100 kg Plasma Motor/Generator (PMG) system, producing 0.1 N of thrust from 0.8 kW, is calculated to save >1,000 kg/year of fuel and keep a 100 kW solar array at the Space Station altitude. A 200 kg PMG system, using 10-15 kW of electrical power, is calculated to produce 1-2 N of thrust--enough to keep the Space Station and a 100 kW solar array in an orbit less than 300 km in altitude, using less than 60 kg/yr of argon for the hollow cathodes. These systems are described in Figure A.32 of the Appendix.

As recommended at the Venice Tether Workshop (October 1985), such a system could be applied to the Space Station, other solar array powered satellites, and the power extension package (PEP), which could then be left in LEO between successive Shuttle flights.

CONTACTS:

o James McCoy

REFERENCES: 5 (pp. 1-17 through 1-30, 3-49 through 3-65, 4-11 through 4-22); 6 (pp. 5-11 through 5-29); 9 (pp. 161-184, 369-377); 13 (pp. 44-50); Application EL.02.00

**ULF/ELF/VLF COMMUNICATIONS ANTENNA
EL.05.00/AUGUST 1986**

APPLICATION: Generation of ULF/ELF/VLF waves by an orbiting electromagnetic tether for worldwide communications.

DESCRIPTION: An insulated conducting tether connected to a spacecraft, and terminated at both ends with plasma contactors. Variations in tether current can be produced to generate ULF/ELF/VLF waves for communications. This tether antenna can be self-powered (using the current induced in it by the geomagnetic field for primary power) or externally powered (fed by an on-board transmitter).

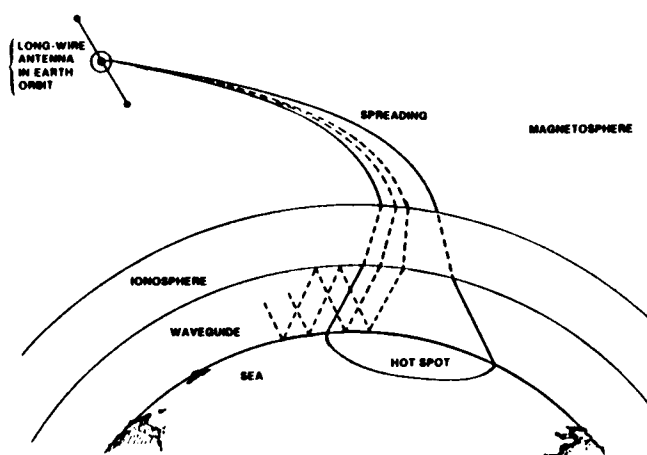

CHARACTERISTICS:

- o LENGTH: 20-100 km
- o TETHER CURRENT: 10 A
- o POTENTIAL FOR TECHNOLOGY DEMONSTRATION: Near-Term

CRITICAL ISSUES:

- o Characterization of the transmitter
- o Characterization of the propagation media (including the ionosphere at LEO altitudes, the lower atmosphere, and ocean water)
- o Analysis of the sources of background noise and the statistical structure of that noise at the receiver
- o Characterization of the instabilities and waves due to large current densities in the Alfvén wings
- o More advanced mathematical models are required for an adequate understanding of tether antenna systems; including the need to supersede the present cold-plasma based models with more accurate warm-plasma based models
- o Determination of optimum ground station locations, including the possibility of mobile receivers
- o Correlation of signals received at different ground station locations to subtract out noise

STATUS:

- o TSS-1, demonstrating electromagnetic applications, is scheduled for a 1988-89 launch

DISCUSSION: When a current flows through the tether, electromagnetic waves are emitted, whether the current is constant or time-modulated. The tether current can be that induced by tether motion through the geomagnetic field, or one generated by an on-board transmitter. Modulation of the induced current can be obtained by varying a series imped-

ance, or by turning an electron gun on the lower tether end on and off, at the desired frequency. Waves are emitted by a loop antenna composed of the tether, magnetic field lines, and the ionosphere.

ULF/ELF/VLF waves produced in the ionosphere will be injected into the magnetosphere more efficiently than those from present ground-based man-made sources. These waves may provide instant worldwide communications by spreading over most of the Earth by ducting. With a 20-100 km tether and a wire current of the order of 10 A, it appears possible to inject in the Earth-ionosphere transmission line power levels of the order of 1 W by night and 0.1 W by day.

CONTACTS:

- o Joseph Kolecki
- o Marino Dobrowolny
- o Georg von Tiesenhausen
- o Paul Penzo

REFERENCES: 5 (pp. 4-11 through 4-22); 6 (pp. 5-11 through 5-29); 9 (pp. 153-160, 369-377, 395-400, 421-439); 15; 16

SATELLITE BOOST FROM ORBITER
TR.01.00/AUGUST 1986

APPLICATION: Boost a satellite payload into a higher circular or elliptical orbit than the Orbiter orbit.

DESCRIPTION: A satellite is deployed along a tether "upwards" (away from the Earth) from the Shuttle Orbiter. Libration begins and momentum is transferred from the Shuttle orbit to the satellite. The satellite is released and placed into a higher orbit while at the same time giving the Shuttle a deboost to return back to Earth. Less fuel is required for both the satellite and the Orbiter. A TSS-derived deployer could be used.

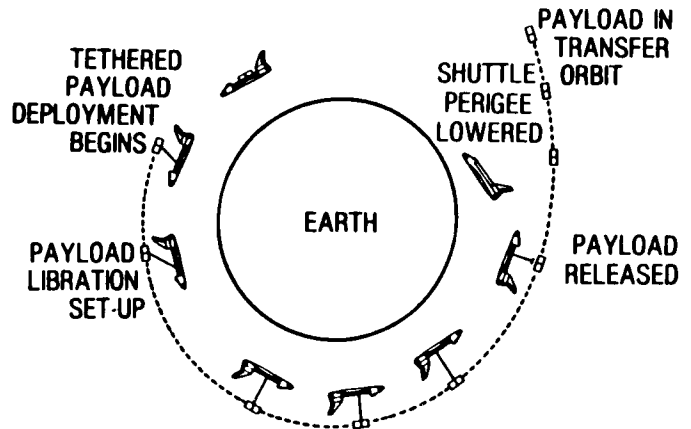

CHARACTERISTICS:

- o **LENGTH:** Dependent on desired orbit (see "Discussion" below)
- o **TETHER SYSTEM:** Either permanent or removable from Orbiter
- o **POTENTIAL FOR TECHNOLOGY DEMONSTRATION:** Near-Term

CRITICAL ISSUES:

- o Release mechanism for payload
- o Airborne support equipment for Orbiter
- o Micrometeorite damage

STATUS:

- o Energy Science Lab development contract to be completed March 1987
- o MIT, Martin Marietta-Denver have completed preliminary assessment
- o Ball Aerospace, selected Tether Applications Study, Phase III

DISCUSSION: This application has been studied in various forms by several contractors as noted above. One example studied is the tethered deployment of the AXAF (Advanced X-Ray Astrophysics Facility) into its operational orbit. For this example, the AXAF is assumed to have a mass of 9,070 kg and the Shuttle (after deployment) a mass of 93,000 kg. With the Shuttle and AXAF at an initial elliptical orbit of 537 x 219 km, the AXAF is deployed along a 61 km tether. As momentum is transferred from Shuttle to AXAF, the Shuttle orbit descends to a new 531 x 213 km and the AXAF orbit ascends to a new 593 x 274 km orbit. After tether separation, the AXAF is directly inserted into a 593 km circular orbit. Simultaneously, the Shuttle takes on an elliptical 531 x 185 km orbit, from which it will make a final OMS burn before its reentry.

CONTACTS:

- o James K. Harrison
- o Joe Carroll
- o Manual Martinez-Sanchez

REFERENCES: 16; 24; Applications TR.02.00, TR.11.00

UPPER STAGE BOOST FROM ORBITER
TR.02.00/AUGUST 1986

APPLICATION: Boost an upper stage payload into a higher orbit.

DESCRIPTION: An upper stage is deployed along a tether "upwards" (away from the Earth) from the Shuttle. Momentum is transferred from the Shuttle to the upper stage, enhancing the performance envelope of the upper stage motor. A TSS-derived deployer system could be used. The Orbiter could be deboosted along with the upper stage boost. Spinup capability for some upper stages may be required.

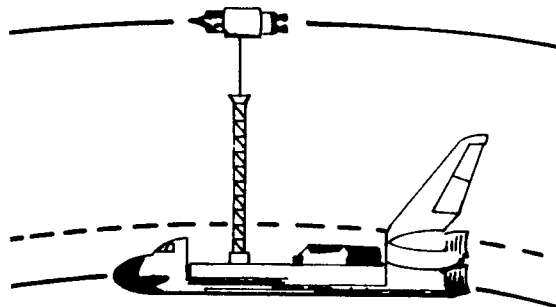

CHARACTERISTICS:

- o LENGTH: Dependent on desired final orbit
- o TETHER DEPLOYMENT SYSTEM: Permanent or removable from Orbiter, TSS-derived
- o POTENTIAL FOR TECHNOLOGY DEMONSTRATION: Near-Term

CRITICAL ISSUES:

- o Requirement for spinup capability may be difficult

STATUS:

- o MDAC assessment complete on this study
- o Martin Marietta, Selected Tether Applications Study, Phase III

DISCUSSION: This application could be tailored to the Orbital Transfer Vehicle (OTV). An expendable tether system or TSS-derived system could eliminate a major portion of the OTV propellant required and increase payload capability for a specific mission with a fixed OTV.

CONTACTS:

- o James K. Harrison
- o Georg von Tiesenhausen
- o Dan McMann

REFERENCES: 8; 16; Applications TR.01.00, TR.11.00

**SHUTTLE EXTERNAL TANK DEORBIT
TR.03.00/AUGUST 1986**

APPLICATION: Shuttle Orbiter boost using momentum scavenging of external tank.

DESCRIPTION: The external tank is brought along with the Shuttle into a stable orbit configuration. The tank is deployed downwards toward the Earth along a tether. The tether is then severed, boosting the Shuttle into its desired orbit while deboosting the external tank into a nonstable orbit for disposal.

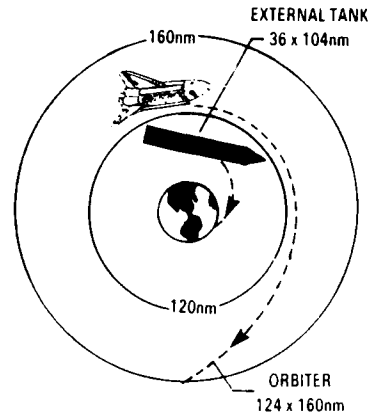

CHARACTERISTICS:

- o TETHER LENGTH: 20 nmi (37 km)
- o POTENTIAL FOR TECHNOLOGY DEMONSTRATION: Near-Term

CRITICAL ISSUES:

- o Shuttle Orbiter impacts
- o Integration costs
- o Permanent vs. removable system
- o Safety/disposal implications
- o Attachment point/mechanism of tether

STATUS:

- o Studied by MM/Michoud
- o Feasibility shown with preliminary design by JSC/EH (Contella)

DISCUSSION: A tethered deployment of the Shuttle external tank would serve several purposes. By transferring momentum from the tank to the Shuttle, less fuel would be required to obtain its desired orbit, and hence, payload capacity is increased. Another benefit of a tethered external tank deorbit is the removal of launch azimuth restrictions caused by the external tank flight pattern over water. A third benefit is the increase in time available for the scavenging of cryo propellants from the external tank.

CONTACTS:

- o James Walker

REFERENCES: 16; 46; 47; 48; 49

PRECEDING PAGE BLANK NOT FILMED

**SHUTTLE DOCKING BY TETHER
TR.04.00/AUGUST 1986**

APPLICATION: Enables Shuttle Orbiter to dock to other structures such as Space Station.

DESCRIPTION: A tether deployed by the Space Station is attached to a docking module. This module would capture and retrieve the Shuttle, allowing a remote rendezvous.

CHARACTERISTICS:

- o TETHER LENGTH: 40 - 100 KM
- o POTENTIAL FOR TECHNOLOGY DEMONSTRATION: Mid-Term

CRITICAL ISSUES:

- o Accurate guidance system needed (such as GPS) to effect rendezvous
- o Rendezvous and capture technique definition required
- o Post-rendezvous tether dynamics
- o Alignment of tether tension with Station center of mass

STATUS:

- o Martin Marietta, Selected Tether Applications Study, Phase III

DISCUSSION: A tether, attached to a docking module, would be deployed towards the Earth from the Space Station. The length of deployment is adjusted so that the velocity of the docking module matches the velocity at apogee of an elliptical orbit of the Shuttle. This would cause increased OMS propellant available to the Shuttle. This application would probably be combined with application TR.05, "Shuttle Deorbit from Space Station."

CONTACTS:

- o James K. Harrison
- o Georg von Tiesenhausen

REFERENCES: 10; 23

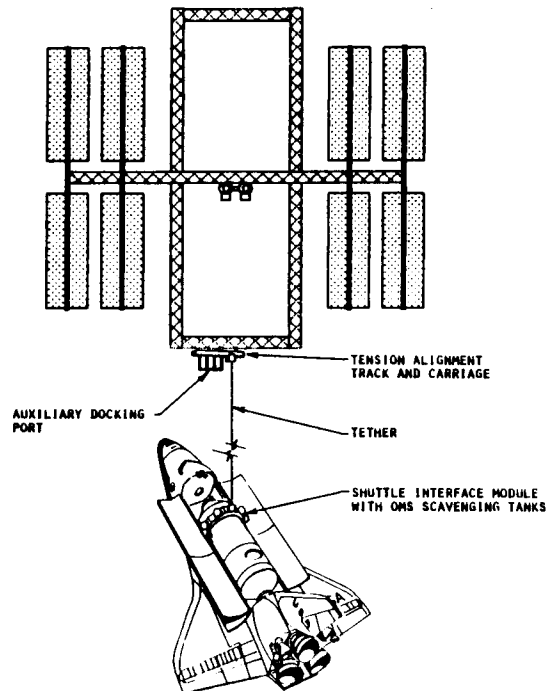

PRECEDING PAGE BLANK NOT FILMED

**GENERALIZED MOMENTUM SCAVENGING FROM SPENT STAGES
TR.05.00/AUGUST 1986**

APPLICATION: Scavenge angular momentum from a spent stage for the benefit of the payload.

DESCRIPTION: After the injection of an upper stage and its payload into an elliptical park orbit, the payload is tethered above the spent stage. At the proper time, the payload is released which causes a payload boost and spent stage deboost.

CHARACTERISTICS:

- o PHYSICAL CHARACTERISTICS: Unknown
- o POTENTIAL FOR TECHNOLOGY DEMONSTRATION: Mid-Term

CRITICAL ISSUES:

- o Mass of tether and reel equipment versus payload performance gain
- o Integration impact on systems

STATUS:

- o Preliminary evaluation completed by MIT and Michoud
- o No further analysis in process

DISCUSSION: This concept appears to be impractical due to mass relationships and integration costs. The most immediate application is for newly developed upper stage/payload combinations and those having a high ratio of spent upper stage to payload mass.

CONTACTS:

- o James Walker
- o Manual Martinez-Sanchez

REFERENCES: 1; 16; 26; 27; 28

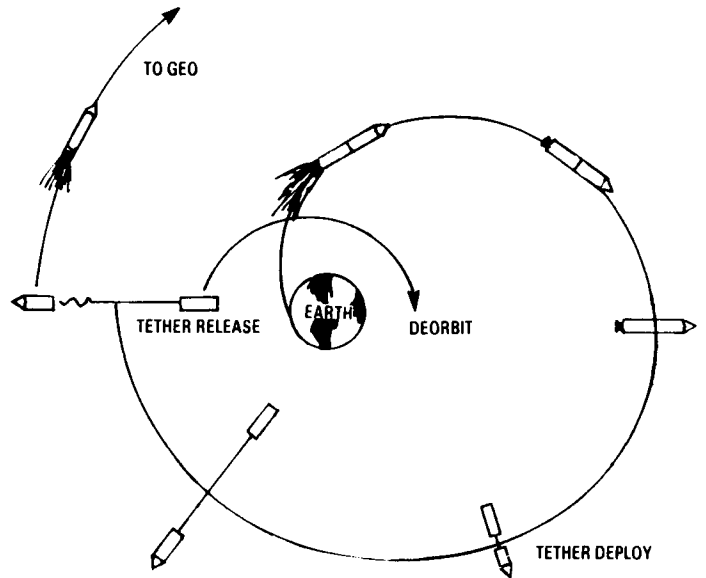

PRECEDING PAGE BLANK NOT FILMED

**TETHERED SAIL (HYPERSONIC RUDDER)
TR.06.00/AUGUST 1986**

APPLICATION: Used to change the orbital inclination of a body such as the Space Shuttle or a satellite.

DESCRIPTION: A hypersonic lifting body tethered below the Shuttle Orbiter is used to generate side forces in order to modify the inclination of the system's orbit. The body must be shifted from one side to the other during the orbit and reeled in and out in order to accomplish this.

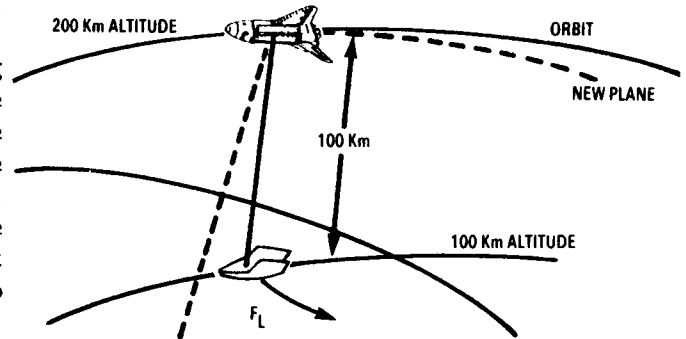

CHARACTERISTICS:

- o TETHER LENGTH: Approximately 100 km
- o POTENTIAL FOR TECHNOLOGY DEMONSTRATION: Far-Term

CRITICAL ISSUES:

- o Performance
- o RCS to counteract drag forces
- o Tether heating
- o Diagnostic Instrumentation

STATUS:

- o This concept is currently believed to be infeasible
- o Preliminary evaluation completed by Wright-Patterson AFB
- o Further consideration by Wright-Patterson AFB is in work

DISCUSSION: This concept can also be used to test tether materials, tether control techniques and aerodynamic control structures if used as a high altitude test bed.

CONTACTS:

- o James Walker
- o Jerome Pearson
- o Joe Carroll

REFERENCES: 16

PRECEDING PAGE BLANK NOT FILMED

**INTERNAL FORCES FOR ORBITAL MODIFICATION (ORBITAL PUMPING)
TR.07.00/AUGUST 1986**

APPLICATION: To change the orbital eccentricity of a Space Station or platform without the use of propulsion systems.

DESCRIPTION: The internal mechanical energy of a Space Station (in the form of excess electrical energy transferred to a motor) is used to vary the length of a tether attached to an end mass. The length is changed in phase with the natural libration of the tether, which is known as libration pumping. Proper timing of tether deployment and retrieval done in this fashion can be used to change the orbital eccentricity.

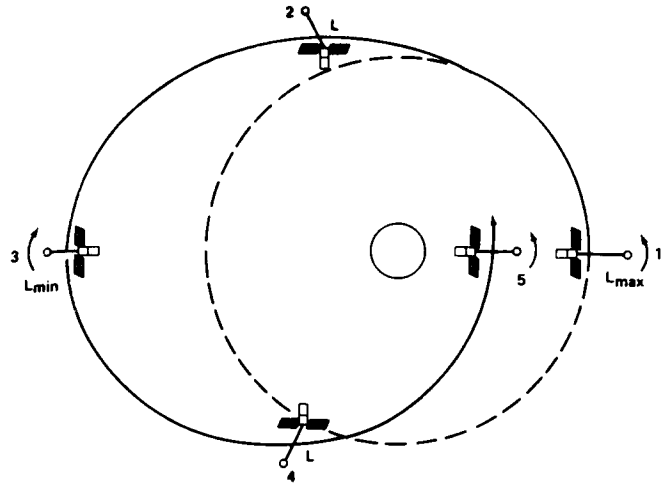

CHARACTERISTICS:

- o PHYSICAL CHARACTERISTICS: Not yet determined
- o POTENTIAL FOR TECHNOLOGY DEMONSTRATION: Mid-Term

CRITICAL ISSUES:

- o Internal vs. external energy trade-off
- o Power required and heat generated by the operation
- o Change in orbits is relatively slow

STATUS:

- o Preliminary feasibility shown by Martin Marietta Denver

DISCUSSION: Orbit eccentricity can be increased by libration pumping as is shown in the illustration. At (1) the mass is fully extended, and libration starts. At (2), with the mass in a prograde swing, the retrieval motor pulls the spacecraft toward the mass, adding energy to the orbit. At (3), which is the new apogee of the orbit, the tether length is at a minimum. At (4), with the mass in a retrograde swing, the tether is re-deployed and the retrieval brakes are used to dissipate orbital energy in the form of excess heat. At (5), the new perigee, the mass is again fully deployed. This procedure is repeated until the desired eccentricity is reached.

CONTACTS:

- o James Walker
- o Manuel Martinez-Sanchez

REFERENCES: 13 (pp. 16-17); 16

**TETHERED REBOOSTING OF DECAYING SATELLITES
TR.08.00/AUGUST 1986**

APPLICATION: To retrieve, repair and reboost a defective or decaying satellite.

DESCRIPTION: A permanent tether attached to the Space Shuttle is used to rendezvous with a decaying satellite. It can then either be repaired by Shuttle crewmen and/or reboosted into a higher orbit. This would eliminate the need to launch a replacement for the defective or decaying satellite.

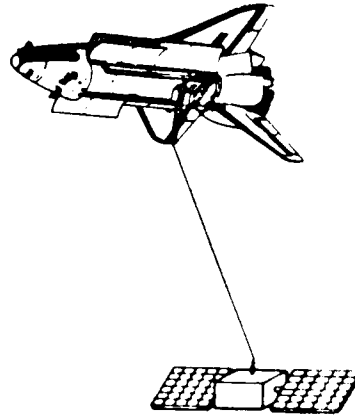

CHARACTERISTICS:

- o PHYSICAL CHARACTERISTICS: Not yet determined
- o POTENTIAL FOR TECHNOLOGY DEMONSTRATION: Near-Term

CRITICAL ISSUES:

- o Mechanisms and rendezvous techniques to capture satellite
- o Compatibility with existing satellite systems
- o Trade-off of the mission and reboost requirements

STATUS:

- o Preliminary analysis indicates feasible concept
- o No defined mission requirement
- o Potential flight experiment application for the Tethered Satellite System

DISCUSSION: Integration of this system may be costly. The concept appears to be feasible, but the practicality has not been established. No mission drivers have yet been determined.

CONTACTS:

- o James Walker
- o Joe Carroll

REFERENCES: 16

PRECEDING PAGE BLANK NOT FILMED

TETHER RENDEZVOUS SYSTEM
TR.09.00/AUGUST 1986

APPLICATION: Used to supplement the operations of the Space Station and OMV.

DESCRIPTION: The Tether Rendezvous System would be used to capture and retrieve payloads, OTV's or the Space Shuttle to the Space Station. The system would consist of a "smart" hook which would be able to rendezvous and attach to a payload with or without human intervention.

CHARACTERISTICS:

- o PHYSICAL CHARACTERISTICS: Not yet determined
- o POTENTIAL FOR TECHNOLOGY DEMONSTRATION: Mid-Term

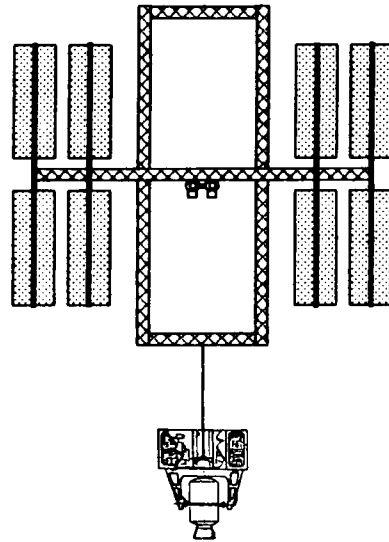

CRITICAL ISSUES:

- o Extent of system capabilities needs to be determined
- o Dynamics in the tether and on the Space Station after rendezvous
- o System design
- o Rendezvous and capture techniques
- o Hardware required

STATUS:

- o Concept under study by Aeritalia
- o Preliminary evaluations have been positive

DISCUSSION: The Tether Rendezvous System can supplement the operations of the Space Station or any space platform by accomplishing remote rendezvous, increasing flexibility, decreasing risk and saving a great amount of propellant for incoming vehicles (OTV, OMV, or the Shuttle Orbiter).

CONTACTS:

- o Chris Rupp
- o Joe Carroll
- o Dale Stuart

REFERENCES: 16; 29

PRECEDING PAGE BLANK NOT FILMED

**SPACE ELEVATOR TO GEOSYNCHRONOUS EARTH ORBIT
TR.10.00/AUGUST 1986**

APPLICATION: Transfer payloads and/or OTV's to and from GEO.

DESCRIPTION: An elevator system composed of a tether and movable platform would connect the surface of the Earth and a space platform beyond GEO.

CHARACTERISTICS:

- o POTENTIAL FOR TECHNOLOGY DEMONSTRATION: Far-Term

CRITICAL ISSUES:

- o Energy requirements for motor
- o Length of the tether exceeds critical length of available materials
- o Micrometeoroid protection
- o Technology of thin-tapered tether
- o Manufacturing and construction

STATUS:

- o Preliminary concept evaluation performed
- o Deferred for further analysis on basis of feasibilities
- o Impractical with current technology and materials

DISCUSSION: The long tapered tether proposed by Tsiolkovsky (1895) and Artsutanov (et al.) reaches from Earth beyond GEO (35800 Km) and utilizes the reduction in gravity gradient and tapering of the tether to position a platform above a surface location. The tether could then be utilized to hoist payloads up to the space platform. A similar system envisioned for the lunar surface is presented in greater detail in application PA.14.00.

CONTACTS:

- o James Walker
- o Joe Carroll

REFERENCES: 16; 30; 31; Application PA.14.00.

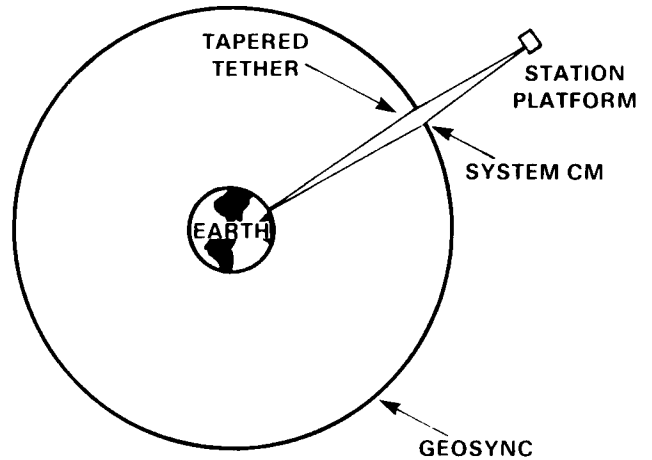

RECORDING PAGE BLANK NOT FILMED

**SMALL EXPENDABLE DEPLOYER SYSTEM
TR.11.00/AUGUST 1986**

APPLICATION: To deploy and boost a payload from the STS into an orbit higher than the STS can itself reach.

DESCRIPTION: This system uses a simple tether deployer about the size of a Get-Away-Special canister. The payload is deployed under low tether tension. This results in near-horizontal deployment, followed by a pendulum swing to the vertical. The orbiter and payload then release the tether simultaneously, and the tether reenters within a few days.

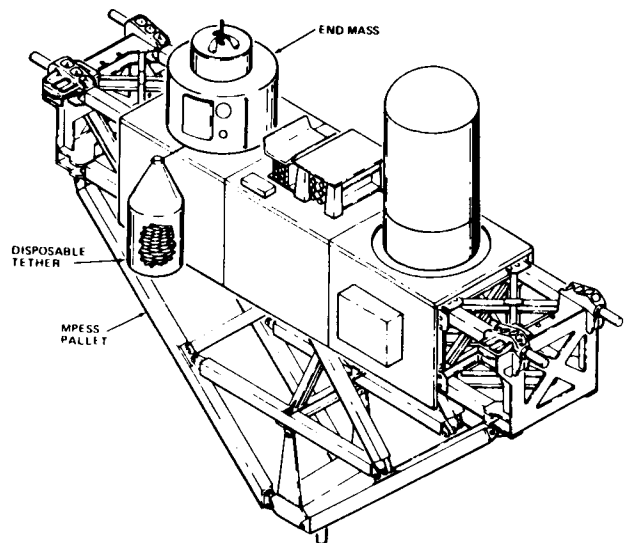

SEDS SYSTEM INTEGRATED TO AN MPESS PALLET

CHARACTERISTICS:

- | | | | |
|--|-----------------|---|-----------|
| o TETHER LENGTH: | 20 km | | |
| o SYSTEM MASS: | 200 kg | | |
| o EFFECTIVE STS
PAYLOAD CAPACITY
INCREASE: | 1400 to 3600 kg | o POTENTIAL FOR
TECHNOLOGY
DEMONSTRATION: | Near-Term |
| o TETHER DIAMETER: | >0.8 mm | | |

CRITICAL ISSUES:

- o Tether and payload oscillations during deployment and pendulum swing
- o Tether failure followed by recoil and fouling on orbiter or payload
- o Tether re-contact with orbiter after release
- o Tether deployer design and performance
- o Overall system reliability

STATUS:

- o SBIR Phase II Development Contract with Energy Science Laboratories to be completed in 1987
- o Under consideration for Technology Demonstration Flight experiment in 1989

DISCUSSION: The operation of this system uses orbiter RCS burns to initiate, adjust, and end the deployment. This simplifies the deployer design and eliminates the need for payload thrusters. Discarding the tether eliminates the time and hardware needed to retrieve it. The SEDS appears to be a very cost-effective enhancement to the STS. Problems such as tether and payload oscillations do appear to be controllable, and several options are being investigated to prevent tether fouling. Typical applications for SEDS include boosting major payloads such as LDEF, or AXAF, reboosting such payloads after servicing (e.g., Solar Max), and boosting minor payloads above the STS mission altitude on multi-user STS missions. A protoflight system of this type could fly shortly after the first TSS mission.

CONTACTS:

- o Joe Carroll
- o James Harrison

REFERENCES: 10 (pp. 5-7, 15-30)

**MULTIPASS AEROBRAKING OF PLANETARY PROBE
TR.12.00/AUGUST 1986**

APPLICATION: Effecting propellant savings through gradual orbit contraction by means of the drag of a lightweight tether.

DESCRIPTION: A small diameter tether is deployed to the local vertical from a probe in a highly elliptical orbit about a planet possessing an atmosphere. At each successive periapsis pass the lowermost region of the tether experiences rarefied flow, thus creating drag on the probe-tether system and gradually reducing the orbit's apoapsis. An instrument package at the tether tip could enhance mission science by taking data during the atmospheric passes.

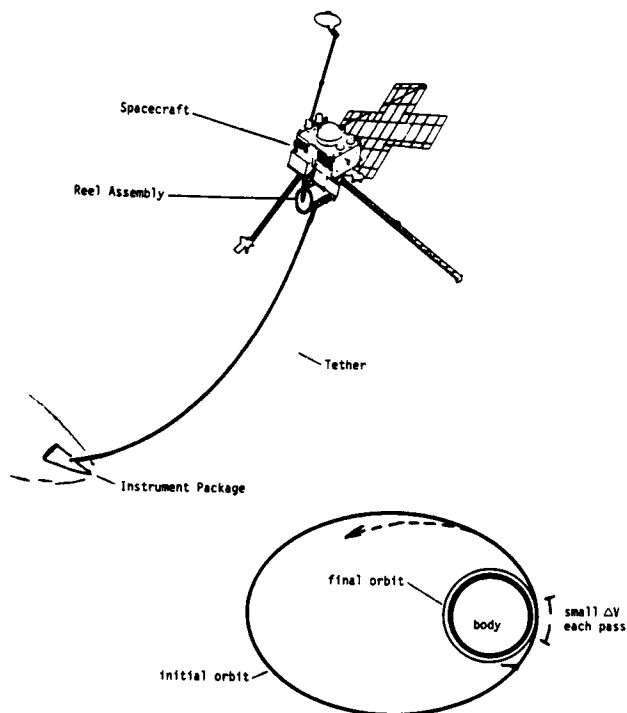

CHARACTERISTICS:

- o TETHER LENGTH: 100-300 km
- o TETHER DIAMETER: ~2mm
- o TETHER SYSTEM: Single reversible reel/brake
- o SPACECRAFT: Conventionally designed for the space environment
- o POTENTIAL FOR TECHNOLOGY DEMONSTRATION: Mid-Term

CRITICAL ISSUES:

- o Possible severence due to prolonged exposure to micrometeoroid hazard
- o Tether stability and control during aerobraking passes in highly elliptical orbits

STATUS:

- o Preliminary study of the shapes, tensions, and drag of a flexible, massive tether in static, circular aerobraking have been performed
- o Further study is required to determine open and closed-loop dynamical behavior of such a tether during aerobraking from highly elliptical orbits
- o TSS-2 will demonstrate the behavior of a tether subjected to aerodynamic forces

DISCUSSION: Conventional planetary probes carry substantial propellant to establish low orbits about a body of interest. An alternative method uses only enough propellant to achieve a highly elliptical "capture" orbit. The spacecraft, now modified to avoid contamination and protected by a large circular shield, then effects a gradual reduction in the height of apoapsis through successive, drag-producing

passes in rarefied flow at periapsis. This method requires the following: (1) A large, heat-resistant shield (or "aerobrake") in front of the spacecraft; (2) an unconventional spacecraft design protected from flow effects in the aerobrake's wake; (3) careful adjustment of the angle-of-attack during each atmospheric pass; and (4) orbit trim maneuvers at apoapsis to insure proper altitude at periapsis.

The tether approach would allow a conventional, unprotected spacecraft to use a bare tether to circularize an elliptical orbit in times comparable to those of a typical hard-shield aerobrake. The creation of the necessary drag could be shared between the lowest portion of tether equivalent in length to one or two atmospheric scale heights and a suspended body at the tether tip. In addition this end mass could give added control. Varying the tether length allows adjustment of the total drag on the spacecraft-tether system in order to account for unforeseen atmospheric variations and navigation uncertainties encountered during previous atmospheric passes.

CONTACTS:

- o Chris Purvis
- o Paul Penzo

REFERENCES: 39

**TETHER RELEASED RECOVERY SYSTEM
TR.13.00/AUGUST 1986**

APPLICATION: Provides a means of transferring a small payload from the Space Station to the Earth without the use of the Shuttle Orbiter.

DESCRIPTION: A payload (such as processed chemicals, engineering data, etc.) would be deployed along a tether from the Space Station. The tethered payload would be released onto a reentry trajectory such that it would enter the upper atmosphere within one-half orbit. Upon reentry, a guided parachute would open, slowing its reentry speed to permit a soft landing.

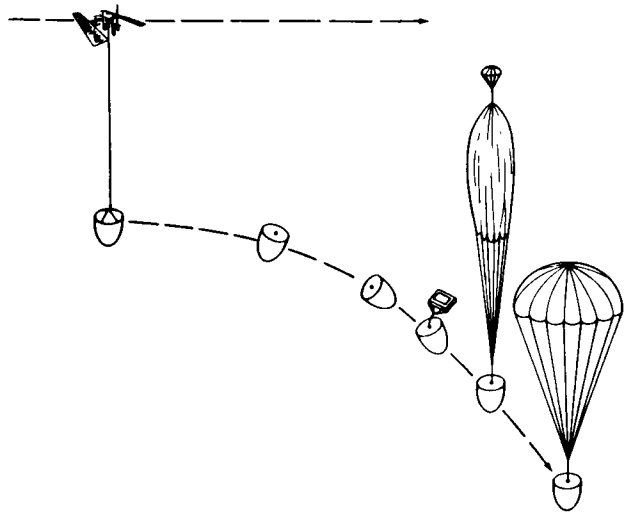

CHARACTERISTICS:

- o TETHER LENGTH: 20-40 km
- o PAYLOAD MASS: 100 kg
- o POTENTIAL FOR TECHNOLOGY DEMONSTRATION: Near-Term

CRITICAL ISSUES:

- o Tether system deployment timing for proper prograde swing
- o Dynamics of tether after payload release

STATUS:

- o Preliminary analysis completed by General Electric
- o Demonstration mission for Shuttle - to be proposed October 1986

DISCUSSION: The time required for the tethered deployment of the payload is approximately 3 hours. An additional 1 hour and 15 minutes is required for the reentry phase after the tether (or payload) is released. The benefits of using a tether for a payload recovery system are reduced sensitivity to payload mass, and elimination of the uncertainties of using rockets for reentry.

CONTACTS:

- o Chris Rupp
- o Dwight Florence

REFERENCES: 20

**ROTATING CONTROLLED-GRAVITY LABORATORY (TETHERED PLATFORM)
CG.01.00/AUGUST 1986**

APPLICATION: Provide a readily accessible variable/controlled-gravity laboratory, capable of generating artificial gravity levels of up to 1 g and over, in Earth orbit.

DESCRIPTION: A tethered platform composed of two end structures, connected by a deployable/retractable 10 km tether. One end structure includes the solar arrays, related subsystems, and tether reel mechanism. The other includes two manned modules and a propellant motor. Artificial gravity is created in the manned modules by extending the tether and firing the motor, rotating the entire system about its center of mass (the solar panels are de-spun). Tether length is used to control the gravity level.

TETHER PLATFORM CONCEPT

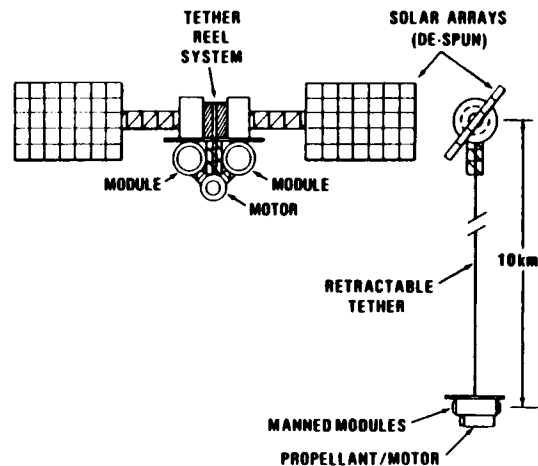

CHARACTERISTICS:

- | | | | |
|------------------|----------------|---|----------|
| o LENGTH: | Up to 10 km | o POTENTIAL FOR TECHNOLOGY DEMONSTRATION: | Far-Term |
| o g-LEVEL: | Up to 1.25 | | |
| o ROTATION RATE: | Up to 0.75 rpm | | |

CRITICAL ISSUES:

- o Susceptibility to micrometeoroid/debris damage

STATUS:

- o No detailed system design study for this application has been performed

DISCUSSION: Access to an orbiting variable/controlled-gravity laboratory, capable of providing artificial gravity levels of up to 1 g and over, would allow vital experimentation in this important gravity range, and provide an appropriate facility, should artificial gravity be determined to be a physiological requirement for extended manned orbital missions. Artificial gravity (in the form of centrifugal acceleration) would be created by rotating the laboratory. The magnitude of the resulting centrifugal acceleration is equal to the square of the angular velocity times the radius of rotation.

Three basic rotating lab configurations are possible - a torus or cylinder (centrifuge), a rigid station, and a tethered platform. The centrifuge is the least attractive because of its relatively small volume, large Coriolis force, and large dynamic disturbance levels. Of the remaining two, the tethered system has several advantages over the rigid

one. It would provide a larger radius of rotation, reducing the rotational rate required to produce a desired g-level. This, in turn, would reduce unwanted side effects, such as the Coriolis force. The variable tether length would also allow a large variety of artificial gravity environments. To spin the system, the tether would be extended to its full 10 km length, and the motor fired. (The minimum necessary Delta-V has been calculated to be 125 m/s.) The tether length would then be adjusted to provide the desired g-level. Assuming the end masses are equal and rotating about a common center, 0.08 g would result from a length of 10 km at a spin rate of 0.12 rpm, 0.16 g (lunar gravity) from a length of 8 km at 0.20 rpm, 0.38 g (Mars gravity) from a length of 6 km at 0.33 rpm, 1 g from a length of 4.30 km at 0.65 rpm, and 1.25 g from a length of 4 km at 0.75 rpm. The solar arrays would be de-spun and sun-oriented. However, a disadvantage is the high Delta-V required to start and stop this spin. Another is the fact that the rotation would probably have to be stopped to allow docking with a spacecraft.

This lab would allow experimentation at gravity levels ranging from low gravity, through Moon, Mars, and Earth gravities, to more than 1 g. The effects of gravity on plant and animal growth, and on human performance and medical processes (such as those related to the cardiovascular, skeletal, and vestibular systems) could be studied for prolonged periods of time. Gravity conditions on the Moon and Mars could be simulated, and the lab could be used to prepare for the possible use of artificial gravity on manned interplanetary missions. It could also provide Earth-like habitability at partial g. Such physical processes as crystal growth, fluid science, and chemical reactions could be studied at various gravity levels.

Additional information on the acceptable values of artificial-gravity parameters is provided in Figure A.7 of the Appendix.

CONTACTS:

o Paul Penzo

REFERENCES: 10 (pp. 125-135); Application PA.09.00

**ROTATING CONTROLLED-GRAVITY LABORATORY (TETHER-ENHANCED STATION)
CG.02.00/AUGUST 1986**

APPLICATION: Provide a readily accessible variable/controlled-gravity laboratory, capable of generating artificial gravity levels of up to about one-half g, in Earth orbit.

DESCRIPTION: A rigid station with two manned lab modules and a tethered, deployable propellant motor at each end of a rotating beam. A hub structure at the center of the beam contains two tether reel and control systems for the motors, and a de-spun solar power system and docking platform. An elevator transfers men and supplies along the beam, to and from the ends. Artificial gravity is created in the lab modules by extending the tethers symmetrically and firing the two motors, rotating the entire system about its center of mass. Tether length is used to control the gravity level.

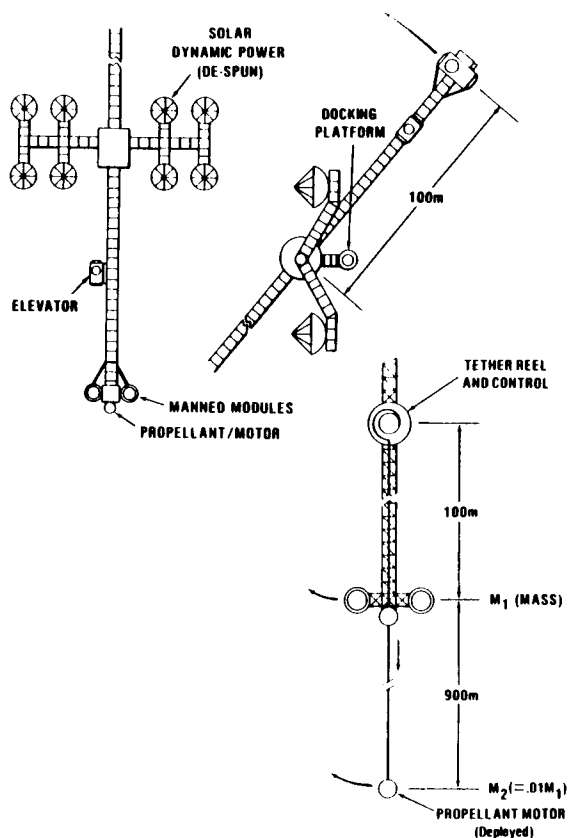

CHARACTERISTICS:

- | | | | |
|-------------------|--------------|------------------|-------------|
| o MODULE ROTATION | | o ROTATION RATE: | Up to 2 rpm |
| RADIUS: | 100 m | o POTENTIAL FOR | |
| o MOTOR ROTATION | | TECHNOLOGY | |
| RADIUS: | 100 - 1000 m | DEMONSTRATION: | Far-Term |
| o g-LEVEL: | Up to 0.45 | | |

CRITICAL ISSUES:

- o Susceptibility to micrometeoroid/debris damage

STATUS:

- o No detailed system design study for this application has been performed

DISCUSSION: Access to an orbiting variable/controlled-gravity laboratory, capable of providing artificial gravity levels of up to about one-half g, would allow vital experimentation in this important gravity range, and provide an appropriate facility, should artificial gravity be determined to be a physiological requirement for extended manned orbital missions. Artificial gravity (in the form of centrifugal acceleration) would be created by rotating the lab station. The magnitude of the resulting centrifugal acceleration is equal to the square of the angular velocity times the radius of rotation.

Three basic rotating lab configurations are possible - a torus or cylinder (centrifuge), a rigid station, and a tethered platform. The centrifuge is the least attractive because of its relatively small volume, large Coriolis force, and large dynamic disturbance levels. The tether-enhanced rigid station combines the best features of the tethered platform and rigid station. It has a shorter radius of rotation than the tethered platform, while using deployable/retractable tethers with the propellant motors to control the station rotation and lab gravity more efficiently than a rigid station alone. The docking platform, which could be de-spun for docking with a spacecraft and then spun to allow the transfer of men and supplies to the lab modules, would allow easy access to the lab modules, without stopping their rotation. A disadvantage of this system is that its spin rate (and associated Coriolis force) would be greater than that of the tethered platform system, for a given gravity level.

The lab modules would be located 100 m from the center of the station, and the propellant motors could be deployed outward from that distance, up to 1000 m from the center. To spin the system, the tethers would be fully and symmetrically deployed, and the motors fired. It has been calculated that a g-level of 0.11 g would result from a tether length (from the end of the rigid beam) of 900 m at a spin rate of 1.0 rpm, 0.16 g (lunar gravity) from a length of 700 m at 1.2 rpm, 0.30 g from a length of 400 m at 1.6 rpm, and 0.45 g from a length of 0 m at 2.0 rpm.

With this lab, the effects of gravity on plant and animal growth, and on human performance and medical processes (such as those related to the cardiovascular, skeletal, and vestibular systems) could be studied for prolonged periods of time. Gravity conditions on the Moon and Mars could be simulated, and the lab could be used to prepare for the possible use of artificial gravity on manned interplanetary missions. It could also provide Earth-like habitability at partial g. Such physical processes as crystal growth, fluid science, and chemical reactions could be studied at various gravity levels.

Additional information on the acceptable values of artificial-gravity parameters is provided in Figure A.7 of the Appendix.

CONTACTS:

- o Paul Penzo

REFERENCES: 10 (pp. 125-135)

VERTICAL TETHERED CONSTELLATION AT GEO
CO.01.00/AUGUST 1986

APPLICATION: Provides a centralized cluster of satellites in a vertical stack, helping to alleviate the arc saturation problem at GEO.

DESCRIPTION: Tether principles are used to provide stability for a constellation of satellites in geosynchronous orbit and provide centralized services for the satellites. The cluster of satellites would be launched by the Shuttle and boosted to GEO by an OTV. Once on station, gravity-gradient forces would be used to deploy the tether connected elements into a stable vertically oriented constellation.

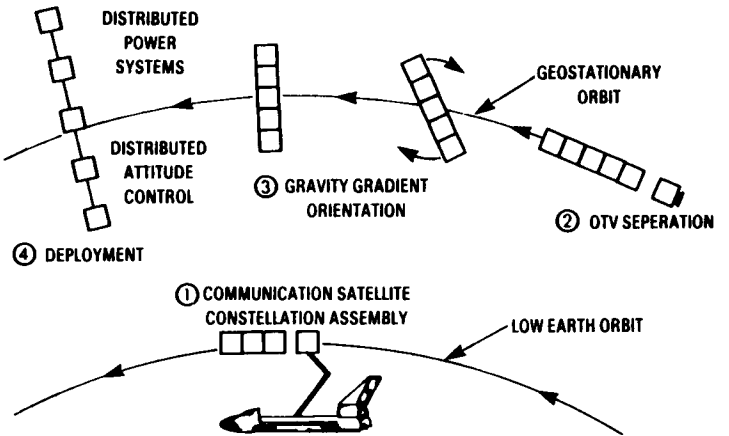

CHARACTERISTICS:

- o POTENTIAL FOR TECHNOLOGY

DEMONSTRATION: Mid-Term

CRITICAL ISSUES:

- o Feasibility of centralized services distributed via the tether
- o Stability to disturbances with reduced gravity-gradient forces at GEO
- o Possible interference of signals and complexity of design and development

STATUS:

- o Basic feasibility of concept investigated at MSFC
- o Preliminary assessment performed under Martin Marietta contract
- o Presently inactive

DISCUSSION: The capability to service and maintain such a constellation would present a level of difficulty considerably beyond that required for a more conventional platform approach.

CONTACTS:

- o Georg von Tiesenhausen

REFERENCES: 32

**COMBINATION OF FREE FLYERS AND TETHERED CONSTELLATIONS
CO.02.00/AUGUST 1986**

APPLICATION: Provides increased flexibility and growth capability for the Space Station for a variety of missions.

DESCRIPTION: Tether-deployed constellations from free flying platforms are integrated with the Space Station architectural concept. This approach would enable each platform to host a variety of otherwise incompatible mission applications.

CHARACTERISTICS:

- o POTENTIAL FOR TECHNOLOGY DEMONSTRATION: Mid-Term

CRITICAL ISSUES:

- o Supply of utilities support to tether-deployed sub-platforms
- o Automated deploy/retrieve operations for sub-platform
- o Servicer rendezvous induced dynamics

STATUS:

- o Preliminary analysis performed
- o Selected Tether Applications Study Phase III
- o Mission requirements not until Space Station growth stage

DISCUSSION: The tether-deployed sub-platforms could be sequentially serviced during a single servicing rendezvous by the Orbital Maneuvering Vehicle services. This concept is considered feasible, however, its implementation will require mature tether deployment technology.

CONTACTS

- o James K. Harrison
- o Jack van Pelt

REFERENCES: 24

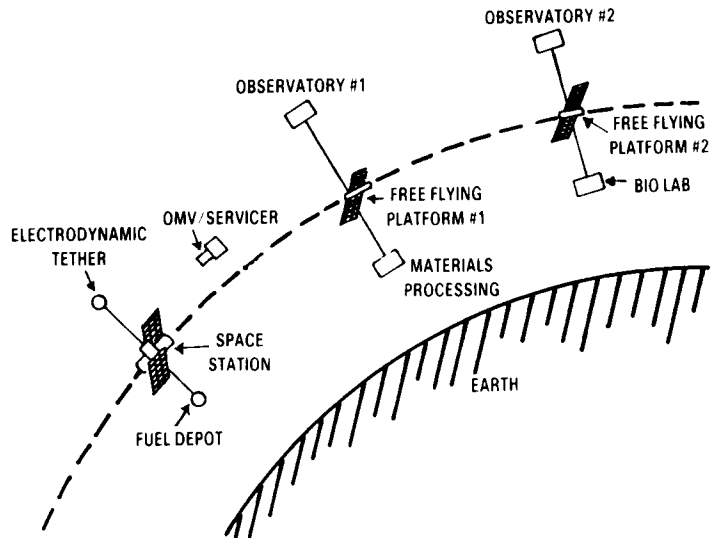

PRECEDING PAGE BLANK NOT FILMED

TETHER STRUCTURES WITH TRUSSES
CO.03.00/AUGUST 1986

APPLICATION: Provides some rigidity and/or separation between tethers for structural purposes.

DESCRIPTION: The application shown uses tethers as the primary attachment between two platforms and uses structural members to separate redundant tethers. A certain degree of torsional stiffness would also be provided. Variations in configurations could range from being predominantly tether to predominantly rigid members.

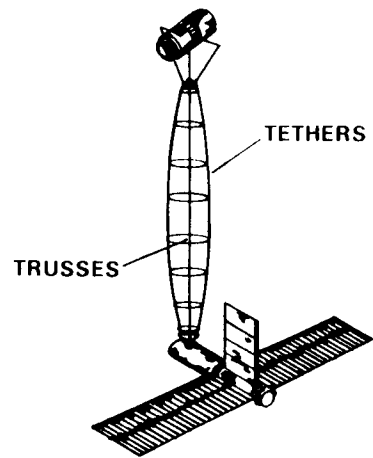

CHARACTERISTICS:

- o POTENTIAL FOR TECHNOLOGY DEMONSTRATION: Mid-Term

CRITICAL ISSUES:

- o Stability characteristics of multi-tether lumped mass system
- o Deployment/retrieval operations
- o Support of tether deployed stages

STATUS:

- o Preliminary analysis performed
- o Further analysis deferred

DISCUSSION: A potential application of such a configuration would be to provide a staged series of platforms at fixed intervals for observation or space physics measurement.

CONTACTS:

- o James Walker

REFERENCES: 16

PRECEDING PAGE BLANK NOT FILMED

**EXTERNAL TANK BASED STRUCTURES
CO.04.00/AUGUST 1986**

APPLICATION: Utilize Shuttle external tanks in a raft format to form a structure in space.

DESCRIPTION: Tethers are used to separate rafts composed of external tanks. These can either be used as a "Space Station" or as structural elements in an evolving Space Station.

CHARACTERISTICS:

- o TETHER LENGTH: 10 - 20 km
- o POTENTIAL FOR TECHNOLOGY DEMONSTRATION: Mid-Term

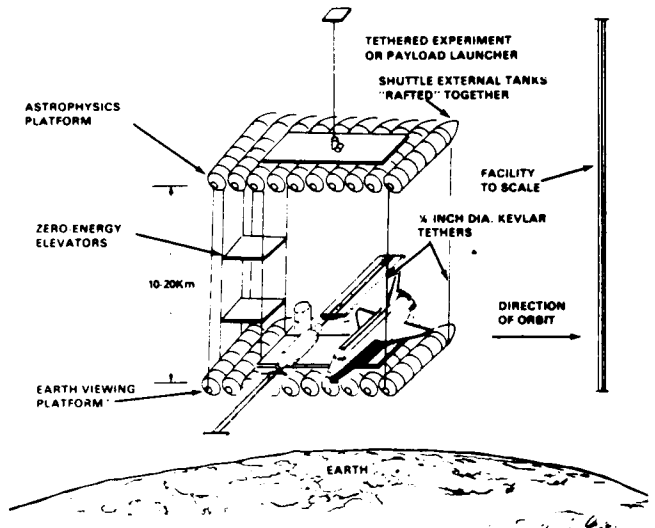

CRITICAL ISSUES:

- o Space operations required to adapt tanks to proposed applications
- o External tank induced contamination environment
- o Stability/controllability of proposed configuration
- o Assembly/buildup operations
- o Drag makeup requirements

STATUS:

- o Preliminary analysis performed
- o Further analyses effort deferred

DISCUSSION: Most likely use of this concept would be as a "space anchor" for tether deployment concepts.

CONTACTS:

- o James Walker
- o Joe Carroll

REFERENCES: 14

PRECEDING PAGE BLANK NOT FILMED

**COMPRESSIVE TETHERS
CO.05.00/AUGUST 1986**

APPLICATION: Provides a force to two objects in space, pushing them apart, such as would be required for initial separation or deployment.

DESCRIPTION: A clothesline-type loop of tether connects two space platforms. The loop is driven from the primary platform through a recoil type pulley on the secondary platform at some velocity V . As the loop is turned through 180° in the recoil pulley, there is a transfer of momentum from the tether to the platform. Conservation of momentum requires an equal but opposite effect to occur at the primary platform. The result is a repulsion force acting to separate the platforms which act like a compression force in the tether.

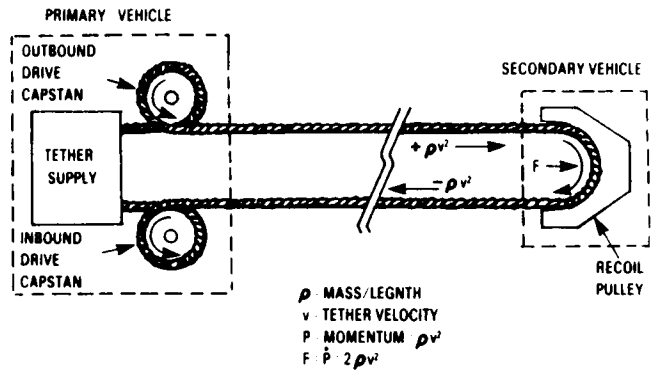

CHARACTERISTICS:

- o PHYSICAL CHARACTERISTICS: Undefined
- o POTENTIAL FOR TECHNOLOGY DEMONSTRATION: Mid-Term

CRITICAL ISSUES:

- o Complexity of drive system to operate over changing distances
- o Interference effects between the counter velocity tether elements
- o Dynamic stability of the system
- o Design concepts for recoil pulley

STATUS:

- o Preliminary analysis performed
- o Further analysis deferred

DISCUSSION: The complexity of this system, especially the moving parts may make this concept prohibitive. Dynamic stability is also a concern.

CONTACTS:

- o H. Mayer

REFERENCES: 16; 33

PRECEDING PAGE BLANK NOT FILMED

**MULTIPROBE FOR ATMOSPHERIC STUDIES
CO.06.00/AUGUST 1986**

APPLICATION: Measurement of spatial geophysical gradients.

DESCRIPTION: A one-dimensional constellation of probes is lowered by the Shuttle or Space Station into the atmosphere in order to provide simultaneous data collection at different locations.

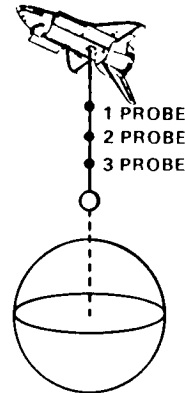

CHARACTERISTICS:

- o PHYSICAL CHARACTERISTICS: Undetermined
- o POTENTIAL FOR TECHNOLOGY DEMONSTRATION: Near-Term

CRITICAL ISSUES:

- o Crawling systems might be necessary
- o Operational sequence for deployment and retrieval

STATUS:

- o Configuration study performed by Smithsonian Astrophysical Observatory

DISCUSSION: This constellation configuration could prove very valuable in low altitude measurements requiring simultaneous data collection at the various probe positions. Good time correlation of the measurements is one benefit of this system.

CONTACTS:

- o Enrico Lorenzini

REFERENCES: 10 (pp. 150-204)

RECORDING PAGE BLANK NOT FILMED

**SPACE STATION TETHERED PLATFORM WITH CONTROLLED GRAVITY LABORATORY
CO.07.00/AUGUST 1986**

APPLICATION: Multi-purpose system providing controlled-gravity variations in a movable laboratory platform as well as service to and from an end platform.

DESCRIPTION: A one-dimensional, three mass constellation that consists of the Space Station and a science/technology platform at opposite ends of a tether in a gravity-gradient-stabilized configuration. A platform on an elevator or crawler mechanism moves vertically between the two tether ends for servicing. Alternatively, the platform can be used as a controlled-gravity laboratory by controlling the time profile g-level.

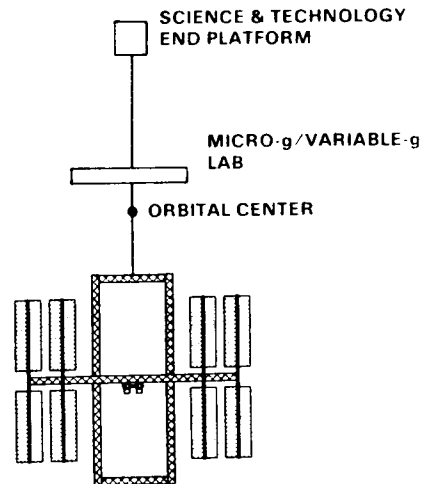

CHARACTERISTICS:

- o PHYSICAL CHARACTERISTICS: 10 km x 2 mm diameter Kevlar tether
- o GRAVITY LEVEL: Controlled, time varying profile up to 10^{-2} g
- o POTENTIAL FOR TECHNOLOGY DEMONSTRATION: Mid-Term

CRITICAL ISSUES:

- o High accuracy accelerometers needed for micro-g applications
- o Smoothly operating reeling or crawling systems needed
- o Dynamic noise induced on movable platform by tether vibrations and/or Space Station vibrations

STATUS:

Analysis performed by Smithsonian Astrophysical Observatory

DISCUSSION: This application is listed as a high priority item in the controlled-gravity/constellation areas. This concept, which has a high feasibility rating, is strongly requested by the micro-g community. A demonstration mission is envisioned on the Space Shuttle by using a modified TSS system with a simplified elevator. Refer to Application SS.04.00 for more detail.

CONTACTS:

- o Enrico Lorenzini

REFERENCES: 10 (pp. 150-204); Application SS.04.00

**SPACE STATION CENTER OF MASS MANAGEMENT WITH A TETHERED PLATFORM
CO.08.00/AUGUST 1986**

APPLICATION: This system allows a tethered platform to be attached to the Space Station while maintaining the center of mass on the Space Station at a desired position.

DESCRIPTION: A tethered ballast is deployed on the side of the Space Station opposite to the side where a tethered scientific platform or payload is deployed. This enables the center of mass, which is approximately coincident with the orbital center, to remain on the Space Station.

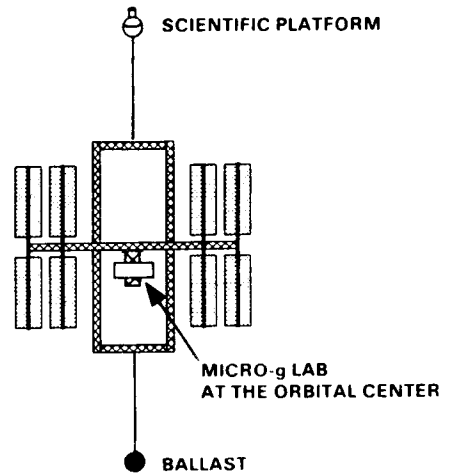

CHARACTERISTICS:

- o TETHER LENGTH: Tether ballast length sized appropriately to match opposing tether attached to scientific platform
- o POTENTIAL FOR TECHNOLOGY DEMONSTRATION: Mid-Term

CRITICAL ISSUES:

- o Accurate accelerometers are needed to sense and control gravity level

STATUS:

- o Configuration study performed by Smithsonian Astrophysical Observatory

DISCUSSION: This configuration is especially necessary if a micro-gravity laboratory is operating on board the Space Station while a scientific platform or other payload is tethered to one side of the Space Station. The tethered ballast provides a way to maintain the "zero-g" point on the Space Station at the desired position. Appropriate control of the deployed length of the tethered ballast would be required if the scientific payload is moved along the tether.

CONTACTS:

- o Enrico Lorenzini

REFERENCES: 10 (pp. 150-204)

PRECEDING PAGE BLANK NOT FILMED

PAGE 3-84 INTENTIONALLY BLANK

**ONE-DIMENSIONAL, DRAG-STABILIZED CONSTELLATION
CO.09.00/AUGUST 1986**

APPLICATION: Not yet determined.

DESCRIPTION: A two mass tethered system is maintained in a horizontal orientation by differential atmospheric drag. In the diagram, the rightmost mass has a larger area to mass ratio than the leftmost mass, causing differential drag.

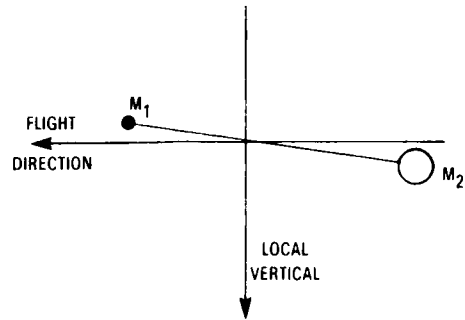

CHARACTERISTICS:

- o MAXIMUM TETHER LENGTH FOR STABLE CONFIGURATION: Approximately 10^4 m @ 150 km altitude
10 m @ 500 km altitude
- o POTENTIAL FOR TECHNOLOGY DEMONSTRATION: Near-Term

CRITICAL ISSUES:

- o Stability is dependent on tether length and altitude
- o Longer tether lengths will require lower operating altitude, imposing a higher orbital decay rate

STATUS:

- o This configuration is currently considered to be infeasible due to stability constraints on tether length
- o Preliminary configuration stability analysis performed by Smithsonian Astrophysical Observatory

DISCUSSION: This constellation configuration is not as inherently stable as a vertical configuration. This is due to the fact that at higher altitudes, such as that of the Space Station, gravity gradient dominates the differential air drag. This would imply using a very short (~10 m) tether at Space Station altitude. At lower altitudes (150 km), longer tether lengths are possible due to stronger differential air drag, but the orbital lifetime is very limited (decay rate could be as high as 4×10^3 km/day).

CONTACTS:

- o Enrico Lorenzini

REFERENCES: 10 (pp. 150-204)

PRECEDING PAGE BLANK NOT FILMED

TWO-DIMENSIONAL "FISH BONE" CONSTELLATION
CO.10.00/AUGUST 1986

APPLICATION: Not yet determined.

DESCRIPTION: A six mass tethered system is configured such that m_1 , m_2 and m_3 are maintained in a vertical gravity-gradient configuration, the same being true for m_4 , m_5 and m_6 . Masses m_4 , m_5 and m_6 have larger area to mass ratios than m_1 , m_2 , and m_3 . Differential air drag maintains separation of the two sets of masses.

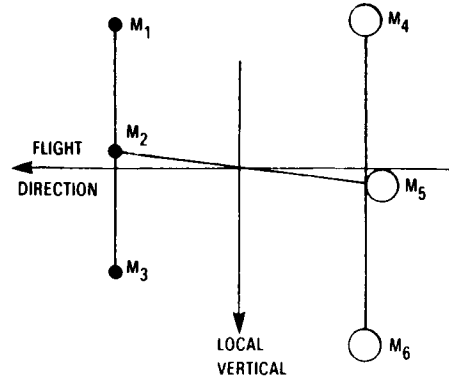

CHARACTERISTICS:

- o TETHER LENGTH
 REQUIRED FOR
 STABLE
 CONFIGURATION: ~ 10⁴ m @ 150 km altitude
 ~ 10 m @ 500 km altitude
- o POTENTIAL FOR
 TECHNOLOGY
 DEMONSTRATION: Far-Term

CRITICAL ISSUES:

- o Stability is dependent on tether length and altitude
- o Longer horizontal tether lengths will require lower operating altitude, imposing a higher orbital decay rate
- o Stability margin for this configuration is more marginal than the one-dimensional drag stabilized configuration (Application CO.09.00)
- o This concept is currently believed to be infeasible

STATUS:

- o Preliminary configuration stability analysis performed by Smithsonian Astrophysical Observatory
- o This configuration not deemed very practical at this time due to stability constraints on tether length

DISCUSSION: This configuration is less stable than the one-dimensional drag-stabilized configuration, Application CO.09.00. The same remarks for CO.09.00 are generally applicable here.

CONTACTS:

- o Enrico Lorenzini

REFERENCES: 10 (pp. 150-204)

PRECEDING PAGE BLANK NOT FILMED

**TWO-DIMENSIONAL DRAG-STABILIZED CONSTELLATION (RECTANGULAR)
CO.11.00/AUGUST 1986**

APPLICATION: Separation of functions in a physically connected configuration.

DESCRIPTION: A four mass tethered system is connected in a rectangular arrangement. Masses 3 and 4 have larger area/mass ratios than 1 and 2. Differential air drag on the masses provides positive tension in the horizontal tethers, while the gravity-gradient configuration causes the vertical sections of tether to be under tension.

CHARACTERISTICS:

- o TETHER LENGTHS: Dependent on orbital altitude. Optimal horizontal/vertical dimension ratio = 1/2
- o BALLOON DIAMETER: 100 m
- o POTENTIAL FOR TECHNOLOGY DEMONSTRATION: Far-Term

CRITICAL ISSUES:

- o Multi-reel system control
- o Better dynamics analysis required

STATUS:

- o Preliminary configuration analysis performed by Smithsonian Astrophysical Observatory

DISCUSSION: No specific applications for this configuration have been proposed. This configuration may prove to be too complex for practical applications.

CONTACTS:

- o Enrico Lorenzini

REFERENCES: 10 (pp. 150-204)

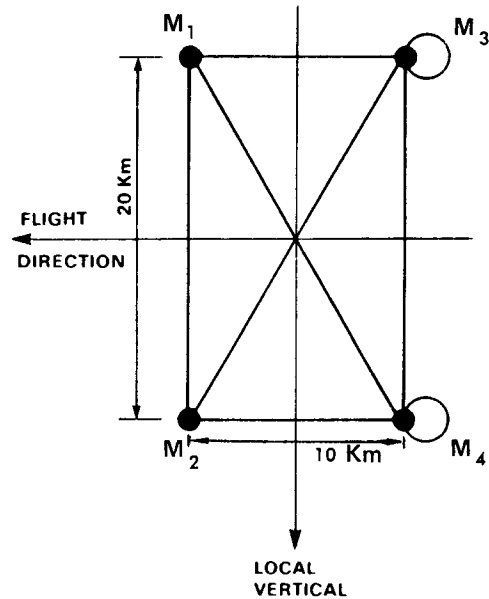

PRECEDING PAGE BLANK NOT FILMED

**TWO-DIMENSIONAL DRAG STABILIZED CONSTELLATION (TRIANGULAR)
CO.12.00/AUGUST 1986**

APPLICATION: No applications have been determined.

DESCRIPTION: Three tethered masses form this system. Masses m_1 and m_2 are stabilized in a gravity-gradient configuration. Mass m_3 , which has a higher area to mass ratio than masses m_1 and m_2 , is drag-stabilized in the horizontal direction.

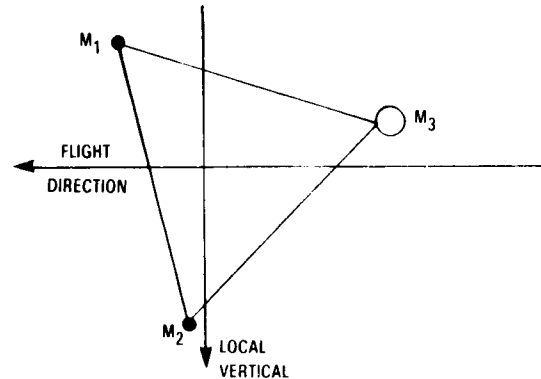

CHARACTERISTICS:

- o PHYSICAL CHARACTERISTICS: Balloon diameter ~ 100 m
- o POTENTIAL FOR TECHNOLOGY DEMONSTRATION: Far-Term

CRITICAL ISSUES:

- o Multi-reel tether system

STATUS:

- o Preliminary configuration study performed by Smithsonian Astrophysical Observatory

DISCUSSION: This configuration exploits drag stabilization to stretch the constellation horizontally in order to provide shape stability.

CONTACTS:

- o Enrico Lorenzini

REFERENCES: 10 (pp. 150-204)

PRECEDING PAGE BLANK NOT FILMED

**TWO-DIMENSIONAL ELECTRODYNAMICALLY STABILIZED CONSTELLATION
CO.13.00/AUGUST 1986**

APPLICATION: Separation of functions in a physically connected configuration.

DESCRIPTION: A four mass tethered system is connected in a rectangular arrangement. Current is generated from an internal source and flows in the outer tether loop. This current interacts with the geomagnetic field, producing electrodynamic forces which push the tether "sides" outward, maintaining the rectangular shape. Gravity gradient maintains the overall attitude stability of the constellation.

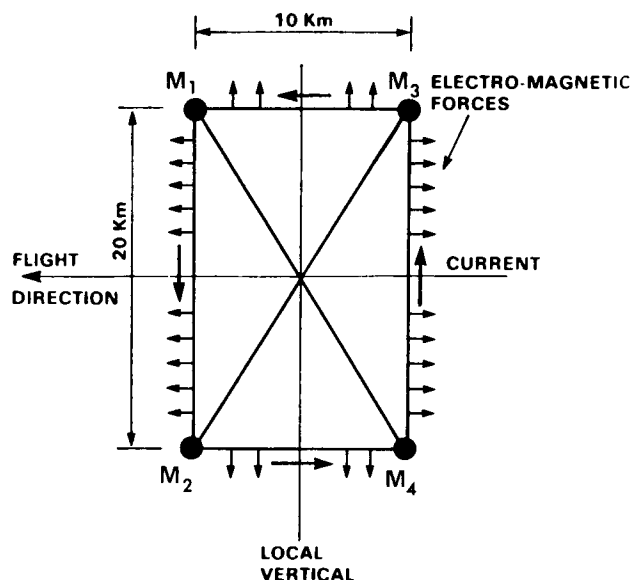

CHARACTERISTICS:

- o TETHER LENGTHS: Optimal horizontal/vertical dimension ratio = 1/2
- o POWER REQUIRED: 7 kW for a 10 x 20 km constellation
- o POTENTIAL FOR TECHNOLOGY DEMONSTRATION: Far-Term

CRITICAL ISSUES

- o Multi-reel system control
- o Better dynamics analysis required

STATUS:

- o Preliminary configuration analysis performed by Smithsonian Astrophysical Observatory

DISCUSSION: No specific applications have been determined for this configuration.

CONTACTS:

- o Enrico Lorenzini

REFERENCES: 10 (pp. 150-204)

PRECEDING PAGE BLANK NOT FILMED

**TWO-DIMENSIONAL PSEUDO-ELLIPTICAL ELECTROMAGNETICALLY
STABILIZED CONSTELLATION
CO.14.00/AUGUST 1986**

APPLICATION: Provides an external frame for stabilizing light structures.

DESCRIPTION: A two mass tethered system is stabilized in a gravity-gradient configuration. An external loop is formed by two electromagnetic tethers through which current flows. This current interacts with the geomagnetic field to produce forces which push the external tethers outwards, forming a pseudo-elliptical shape.

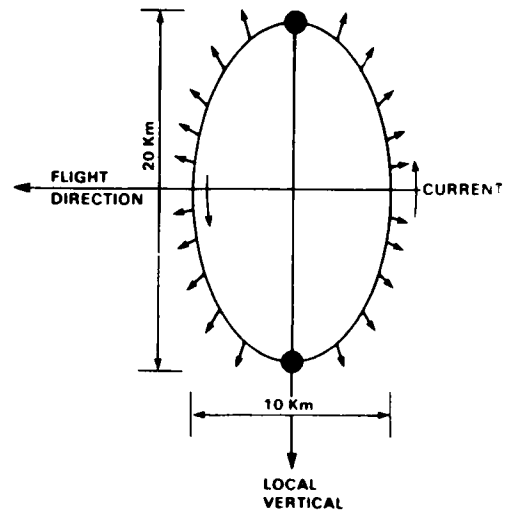

CHARACTERISTICS:

- o DIMENSIONS: As shown in the diagram, approx. 10 x 20 km
- o POWER REQUIRED: 3.5 kW
- o POTENTIAL FOR TECHNOLOGY DEMONSTRATION: Far-Term

CRITICAL ISSUES:

- o Multi-reel system control
- o Stability of system

STATUS:

Preliminary configuration study completed by Smithsonian Astrophysical Observatory

DISCUSSION: This configuration could be used as an external frame for a solar sail or reflector.

CONTACTS:

- o Enrico Lorenzini

REFERENCES: 10 (pp. 150-204)

PRECEDING PAGE BLANK NOT FILLED

**TORQUING OF A SPINNING STATION FOR SPIN AXIS
PRECESSION RATE CONTROL
CO.15.00/AUGUST 1986**

APPLICATION: Provides spin axis precession rate control for a spinning space station.

DESCRIPTION: A gimballed exterior frame connected to the spin axis of a space station has two tethered masses 180° apart from each other, on the perimeter of the spinning station. These tethered masses are deployed in opposite vertical directions from each other, in a gravity-gradient-stabilized configuration. Forces caused by the gravity gradient on the tethers are utilized to provide an external torque, which controls the orientation of the spin axis of the station.

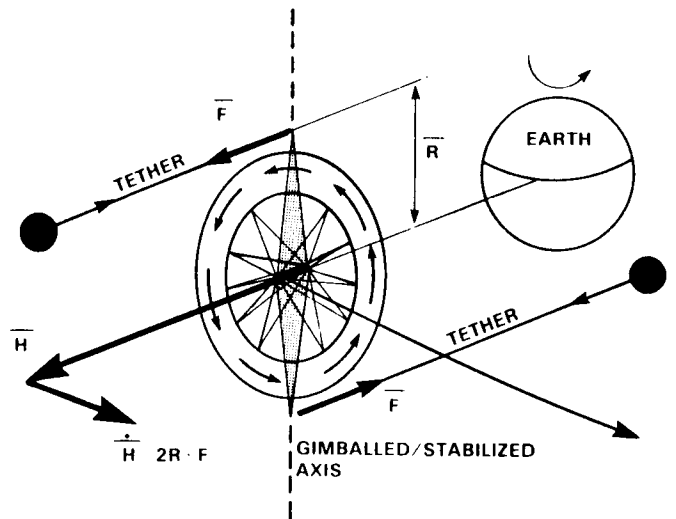

CHARACTERISTICS:

o PHYSICAL

CHARACTERISTICS: Tether length dependent on magnitude of angular momentum vector of space station

o POTENTIAL FOR TECHNOLOGY

DEMONSTRATION: Far-Term

CRITICAL ISSUES:

- o Structural construction of gimballed frame
- o Tether reel control design

STATUS:

Preliminary configuration analysis performed by Smithsonian Astrophysical Observatory

DISCUSSION: Proper utilization of the gravity gradient can be applied to control the space station spin axis attitude (e.g., to keep the spin axis aligned with the local vertical), as well as the spin axis precession rate. Some means of rotating the exterior gimballed frame must be available, such as a variable torque motor.

CONTACTS:

- o Enrico Lorenzini

REFERENCES: 10 (pp. 150-204)

PRECEDING PAGE BLANK NOT FILMED

**SHUTTLE TETHERED AEROTHERMODYNAMIC RESEARCH FACILITY
TT.01.00/AUGUST 1986**

APPLICATION: Provides a unique tool to measure aerothermodynamic properties of the atmosphere around 100 km altitude.

DESCRIPTION: A tethered subsatellite, equipped with various scientific instruments, is towed by the Shuttle vertically down towards the Earth.

CHARACTERISTICS:

- o LENGTH: 110 km (max)
- o MASS: 500 kg
- o POWER REQUIRED: TBD
- o POTENTIAL FOR TECHNOLOGY DEMONSTRATION: Near-Term

CRITICAL ISSUES:

- o High temperature tethers required below 125 km altitude
- o Measurement R&D needed in flow field profiling, density and gas analysis
- o System monitoring and control instrumentation

STATUS:

- o STARFAC feasibility/definition results completed
- o SCOWT study ongoing in support of STARFAC and TSS-2
- o TSS-2 mission in planning which will incorporate same objectives

DISCUSSION: STARFAC will enable aerothermodynamic research to be performed in a region of the Earth's atmosphere which is presently unattainable for extended periods of time. This region is 90 to 125 km above the Earth's surface, and measurements may be made up to 200 km. Presently, atmospheric measurements in this region of the atmosphere can only be made with sounding rockets, and then over small areas of area and time. Tether material selection and/or development in this region may require materials under high loads operating in excess of 100 K.

CONTACTS:

- o Paul Siemers
- o George Wood
- o Giovanni Carlomagno
- o Luigi de Luca

REFERENCES: 10 (pp. 251-286)

SHUTTLE TETHERED AEROTHERMODYNAMIC RESEARCH FACILITY

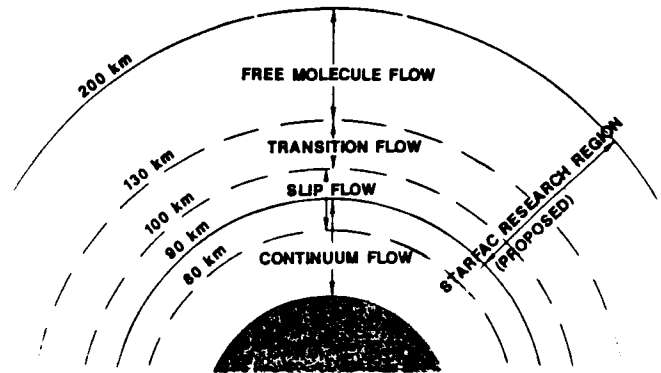

PRECEDING PAGE BLANK NOT FILMED

PAGE 3-100 INTENTIONALLY BLANK

**SHUTTLE CONTINUOUS OPEN WIND TUNNEL
TT.02.00/AUGUST 1986**

APPLICATION: A tethered fixture attached to the Space Shuttle provides a "wind tunnel" testbed by towing aerodynamic bodies through the atmosphere.

DESCRIPTION: A variable length tether, nominally 100 km in length, would tow various aerodynamic models. Various parameters such as heat transfer coefficients and drag coefficients could be accurately measured.

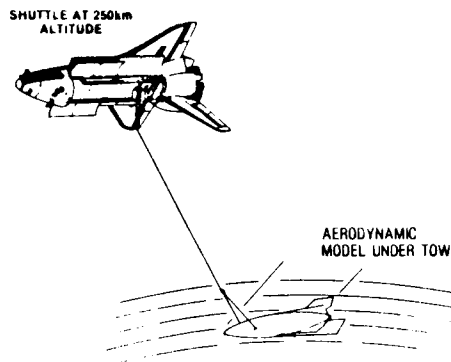

CHARACTERISTICS:

- o LENGTH: Nominally 100 km
- o MASS: Undetermined
- o POWER REQUIRED: For data collection only
- o POTENTIAL FOR TECHNOLOGY DEMONSTRATION: Near-Term

CRITICAL ISSUES:

- o Dynamic noise needs to be accurately determined

STATUS:

- o Shuttle Continuous Open Wind Tunnel program ongoing
- o STARFAC
- o AOTV, ERV program-related

DISCUSSION: Unique measurements could be made possible due to the combined low Reynolds number and large Mach number regime available. More realistic measurements regarding air flow and turbulence are possible. An additional advantage of using the Shuttle "wind tunnel" is the longer testing time periods available. (TSS, for example, is currently scheduled for a 36-hour mission.)

CONTACTS:

- o Franco Mariani
- o Paul Siemers
- o Giovanni Carlomagno
- o George Wood
- o L. De Luca

REFERENCES: 10 (pp. 225-250)

PRECEDING PAGE BLANK NOT FILMED

PAGE 3-142 INTENTIONALLY BLANK

**TETHERED ORBITAL REFUELING FACILITY
SS.01.00/AUGUST 1986**

APPLICATION: Utilization of artificial gravity to assist in the transfer of liquid propellants to and from a tethered storage and refueling platform.

DESCRIPTION: A platform (depot) with liquid propellant storage tanks and remote manipulators, tethered a short distance above or below the Space Station. The gravity gradient between the Space Station and the depot produces a tension in the tether, resulting in an equal and opposite artificial-gravity force throughout the depot. The artificial gravity allows fluid settling in the tanks (liquid settles over an outlet and gas over a vent), facilitating propellant handling. The depot can be refilled by the Shuttle, providing a long-term remote refueling capability.

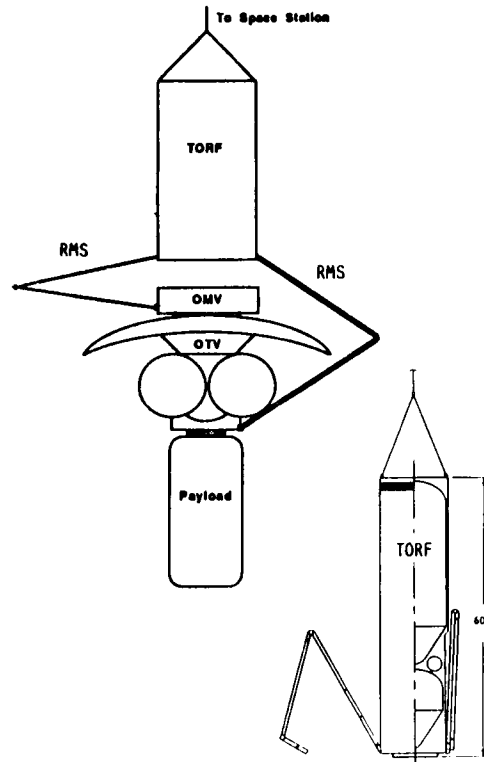

CHARACTERISTICS:

- | | | | |
|------------------|------------------------|---|----------|
| o PROPELLANTS: | Cryogenic and Storable | o POTENTIAL FOR TECHNOLOGY DEMONSTRATION: | Far-Term |
| o TETHER LENGTH: | 1 km (Cryogens) | | |
| o FUEL CAPACITY: | 100,000 lbs (Cryogens) | | |

CRITICAL ISSUES:

- o Design of the vapor return line to assure that it will not be blocked by trapped liquids during transfer
- o Design of tank baffling to prevent the inflow jet from covering the gas vent with liquid, while also controlling liquid slosh
- o Prevention of propellant contamination of sensitive Space Station surfaces
- o Evaluation of the overall impacts to the Space Station
- o Evaluation of the tether system's cost effectiveness
- o Determination of human access and control requirements

STATUS:

- o The TORF is the first design proposed for a tethered OTV refueling facility - it is now considered too small for currently projected requirements and has been superseded by the Tethered OTV Hangar/Depot (Application SS.02.00); however, the TORF design may prove to be useful in the future for other types of refueling

- o The final report for the current JSC Tethered Orbital Refueling Study (including a cost/benefits comparison of tether and zero-g refueling systems) is expected in June 1986
- o The main emphasis is on cryogenic propellants
- o Detailed design of the propellant depot has not been done
- o The Spinning Shuttle Experiment is the planned demonstration for this concept

DISCUSSION: In this stable vertical system, the level of artificial gravity at the Tethered Orbital Refueling Facility (TORF) is proportional to the tether length between the center of mass of the entire Space Station/TORF system and the TORF. To determine the minimum gravity level (and tether length) required to overcome surface tension and allow fluid settling, a nondimensional number, the Bond number (Bo), can be calculated for each liquid propellant (see Figure A.11 of the Appendix). It is a fluid settling parameter, equal to the product of the fluid density, acceleration, and square of the tank diameter, divided by 4 times the fluid surface tension coefficient. (Although a fluid will settle if $Bo \geq 10$, a value of $Bo = 50$ is used to be conservative.) Using this value, the minimum required tether length has been calculated for each of the following propellants: 32.3 m for oxygen; 71.3 m for hydrogen; 342.0 m for nitrogen tetroxide; 719.0 m for monomethylhydrazine; and 1235.0 m for hydrazine. (Assuming that cryogenic propellants use a tank diameter of 4.2 m to fit in the Shuttle cargo bay, and storable propellants use a tank diameter of 1.7 m to fit side-by-side in the Shuttle bay.) Fluid slosh, from single and multiple disturbances, would be controlled by using tethers of at least 1 km in length, and by using tanks with a conical bottom and ring-type internal baffle.

Fluid settling would allow the use of a vapor return line from the receiver tank to the supply tank. This would permit receiver tank venting without dumping the gas overboard (where it would pose a contamination hazard), eliminate the need to resupply pressurant for the liquid transfer, and provide an equalizing supply tank pressure. Due to the availability of extra gas and limited pressure at a pump, a compressor in the vapor return line has been recommended to transfer cryogenic propellants. Due to the opposite conditions, a pump in the liquid transfer line has been recommended to transfer storable propellants. The gravity feed method could be used as a backup for either; however, it would be considerably slower. Calculations have also shown that a tether long enough for settling would overcome the acceleration due to the initial fluid transfer impulse.

The TORF would separate hazardous liquid storage and transfer from the Space Station; thus reducing the hazards related to propellant contamination, tank explosion, and spacecraft docking. Remote manipulators would provide remote maneuvering of the spacecraft during refueling, and the tether could be released if a catastrophic problem were imminent. (The fluid settling technique could also be applied to liquids other than propellants, if desired.) A possible disadvantage of the TORF would be the vertical shift in the center of gravity to a point off of

the Space Station, produced unless another tethered system balanced the TORF. Currently, an intermittent deployment is preferred because it would minimize the impact to microgravity experiments, and require no sustained counterbalancing.

The latest cryogenic propellant depot design would hold 100,000 lbs of fuel (equal to two Centaur loads), and could be launched in a single Shuttle flight. Auxiliary propulsion would be needed to overcome the drag produced by atmospheric drag, and spacecraft berthing. For continuous drag make-up, using only H₂ boiloff in cold gas thrusters, a specific impulse of 200 s would be adequate for TORF auxiliary propulsion (570 s for both the TORF and Space Station).

CONTACTS:

o Kenneth Kroll

REFERENCES: 9 (pp. 223-238); 10 (pp. 89-123); 13 (pp. 64-72, 78-80)

TETHERED OTV HANGAR/DEPOT
SS.02.00/AUGUST 1986

APPLICATION: Provide an OTV facility for the Space Station, combining a hangar with a propellant depot, which utilizes artificial gravity to assist in liquid propellant transfers.

DESCRIPTION: A combined OTV hangar/depot facility with liquid propellant storage tanks and remote manipulators, tethered a short distance above or below the Space Station. The gravity gradient between the Space Station and this facility produces a tension in the tether, resulting in an equal and opposite artificial-gravity force throughout the facility. The artificial gravity allows fluid settling in the tanks, facilitating propellant handling. The tanks can be refilled by the Shuttle, providing a long-term remote OTV refueling capability.

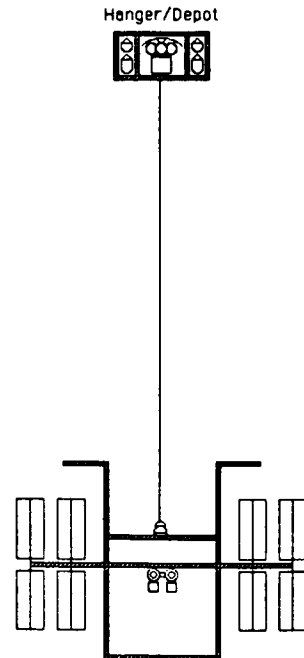

CHARACTERISTICS:

- | | | | |
|------------------|--------------------------|---|----------|
| o PROPELLANTS: | Cryogenic and Storable | o POTENTIAL FOR TECHNOLOGY DEMONSTRATION: | Far-Term |
| o TETHER LENGTH: | 1 km (Cryogenics) | | |
| o FUEL CAPACITY: | 200,000 lbs (Cryogenics) | | |

CRITICAL ISSUES:

- o Design of the vapor return line to assure that it will not be blocked by trapped liquids during transfer
- o Design of tank baffling to prevent the inflow jet from covering the gas vent with liquid, while also controlling liquid slosh
- o Prevention of propellant contamination of sensitive Space Station surfaces
- o Evaluation of the overall impacts to the Space Station
- o Evaluation of the tether system's cost effectiveness
- o Determination of human access and control requirements

STATUS:

- o This is the latest design for a tethered OTV hangar/refueling facility on the Space Station
- o The main emphasis is currently on cryogenic propellants
- o The final report for the current JSC Tethered Orbital Refueling Study (including a cost/benefits comparison of tether and zero-g refueling systems) is expected in June 1986

- o Detailed design of the hangar/propellant depot and OTV remains to be done
- o The Spinning Shuttle Experiment is the planned demonstration for this concept

DISCUSSION: Current planning has determined a preferred OTV design, requiring twice the depot propellant quantities provided by the "Tethered Orbital Refueling Facility" (Application SS.01.00). (Detailed descriptions of liquid propellant settling and transfer are presented in that application, and in Figure A.11 of the Appendix.) It has also been determined that basing an OTV on the Space Station would require the addition of a large hangar, significantly shifting the Space Station center of gravity laterally. These problems could be overcome by combining a hangar with two tethered propellant depots, of the type described in Application SS.01.00. Such a hangar/depot facility would eliminate the need to ferry the OTV and its attached payload from the Space Station to a tethered depot for refueling, simplify OTV refueling, and would allow the attachment of another tether to the bottom of the facility. It could also service other spacecraft as desired. A possible disadvantage would be the vertical shift in the center of gravity to a point off of the Space Station, produced unless another tethered system balanced this facility. Currently, an intermittent deployment is preferred because it would minimize the impact to microgravity experiments, and require no sustained counterbalancing. The OTV could be launched from the deployed depot, minimizing its effects on the Space Station.

CONTACTS:

- o Kenneth Kroll

REFERENCES: 9 (pp. 223-238); 13 (pp. 64-72, 78-80); 53; Application SS.01.00

**MICROGRAVITY LABORATORY
SS.03.00/AUGUST 1986**

APPLICATION: Provide a readily accessible laboratory in Earth orbit with the minimum gravity level possible.

DESCRIPTION: A laboratory facility on board the Space Station at its vertical center of gravity. Two opposing tethers with end masses are deployed vertically from the Space Station (one above and one below). Their lengths are varied to control the Space Station center of gravity, placing it on the microgravity modules to minimize their gravity gradient acceleration (artificial-gravity level).

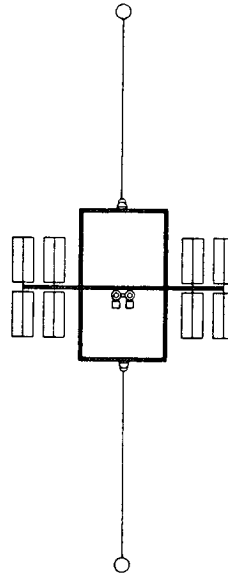

CHARACTERISTICS:

- | | |
|--|--|
| <ul style="list-style-type: none"> o PHYSICAL CHARACTERISTICS: Undetermined o g-LEVEL: 10^{-4} and less | <ul style="list-style-type: none"> o POTENTIAL FOR TECHNOLOGY DEMONSTRATION: Mid-Term |
|--|--|

CRITICAL ISSUES:

- o Evaluation of the overall impacts to the Space Station
- o Determination of just how good the lab's microgravity would be
- o Identification of the processes and technologies to be studied in microgravity, and the laboratory facilities and capabilities they will require
- o Development of the necessary gravity-measuring instrumentation
- o Evaluation of the tether system's cost effectiveness

STATUS:

- o A JSC tethered gravity laboratory study (addressing the issues of active center-of-gravity control, identification of low-gravity processes to be studied, and evaluation of the laboratory g-level quality) will begin this year (procurement beginning in March, and the study in September)
- o An MSFC study for definition of the Microgravity Materials Processing Facility (MMPF) for the Space Station is in progress
- o The Small Expendable Deployer System (SEDS) mission (scheduled for a 1989 launch) may provide measurements of the acceleration field change and associated noise throughout the Shuttle, during tether and payload deployment
- o TSS-1 will demonstrate and analyze the acceleration field and associated noise, during all phases of tether operations

DISCUSSION: To allow the performance of experiments under microgravity conditions (10^{-4} g and less) for extended periods of time, a microgravity laboratory facility could be incorporated into the Space Station. The laboratory modules would be located on the Space Station proper, at its center of gravity. Two opposing TSS-type tethers with end masses would be deployed vertically from the Space Station (one above and one below), to assure that the station center of gravity is maintained within the lab modules. Its exact location would be controlled by varying the upper and lower tether lengths, allowing prolonged and careful control of the residual microgravity magnitude and direction inside the lab. A nearly constant microgravity could be maintained. These tethers would lower the gravity-gradient disturbances transmitted to the experiments being performed, while enhancing station attitude control. Although people would be a major source of disturbances, human access to microgravity experiments is preferred (at least initially) over remote access. This configuration would easily accommodate this preference.

One candidate microgravity lab, currently under study for the Space Station, is the Materials Technology Lab (MTL). It is projected to be a common module, equipped as a lab, to perform a variety of experiments related to materials technology. Biological experiments may also be performed in microgravity in another module.

Although this is the preferred microgravity lab configuration, two alternatives are also possible. One would be to have the lab connected by a crawler to a single tether from the Space Station. The crawler would position the lab on the station-tether system center of gravity. The other configuration would be to fix the lab to a single tether from the station. The lab would be positioned at the system center of gravity by varying the tether length. Both alternatives have the advantage of isolating the lab from disturbances, but they have the disadvantages of reducing human access, and of probably precluding the use of the microgravity modules planned for the initial Space Station.

Comparisons of the reduced-gravity environments produced by tethered platforms and alternative facilities are presented in Figures A.8, A.9, and A.10 of the Appendix.

CONTACTS:

- o Kenneth Kroll

REFERENCES: 9 (pp. 223-238); 10 (pp. 53-77, 87, 137-147); 13 (pp. 64-66, 70-75, 78-80); 53

VARIABLE/LOW GRAVITY LABORATORY
SS.04.00/AUGUST 1986

APPLICATION: Provide a readily accessible laboratory in Earth orbit with a variable, low gravity level.

DESCRIPTION: A laboratory facility, attached by a crawler to a tether deployed vertically from the Space Station. The gravity gradient between the station-tether system center of gravity and the laboratory produces an artificial-gravity force throughout the lab. The lab gravity level, with a constant vertical direction, is varied by changing the lab and crawler distance from the system's center of gravity. The lab can attain microgravity levels if it can move to the center of gravity.

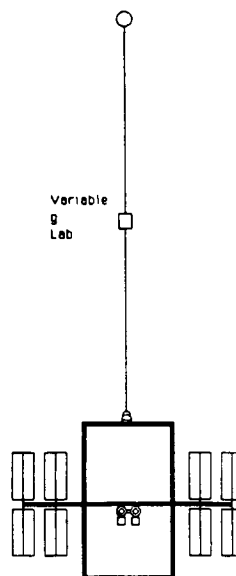

CHARACTERISTICS:

- | | |
|---|--|
| <ul style="list-style-type: none"> o PHYSICAL CHARACTERISTICS: Undetermined o g-LEVEL: Up to 10^{-1} | <ul style="list-style-type: none"> o POTENTIAL FOR TECHNOLOGY DEMONSTRATION: Far-Term |
|---|--|

CRITICAL ISSUES:

- o Evaluation of the overall impacts to the Space Station
- o Determination of just how good the lab's low gravity would be
- o Identification of the processes and technologies to be studied in low gravity, and the laboratory facilities and capabilities they will require
- o Development of the necessary gravity-measuring instrumentation
- o Evaluation of the tether system's cost effectiveness
- o Determination of how gravity-level medical experiments should be performed in a Space Station system
- o Design of a tether crawler and lab module
- o Development of systems for the remote control of lab experiments

STATUS:

- o A JSC tethered gravity laboratory study (addressing the issues of active center-of-gravity control, identification of low-gravity processes to be studied, and evaluation of the laboratory g-level quality) will begin this year (procurement beginning in March, and the study in September)
- o An MSFC study for definition of the Microgravity Materials Processing Facility (MMPF) for the Space Station is in progress
- o The Small Expendable Deployer System (SEDS) mission (scheduled for a 1989 launch) may provide measurements of the acceleration field change and associated noise throughout the Shuttle, during tether and payload deployment

- o The Spinning Shuttle Mission should provide initial investigations of controlled-gravity and threshold phenomena in the 10^{-1} g to 10^{-4} g range
- o TSS-1 will demonstrate and analyze the acceleration field and associated noise, during all phases of tether operations

DISCUSSION: To allow the performance of experiments under conditions of constant or variable low gravity (up to 10^{-1} g) for extended periods of time, a variable/low gravity lab could be attached to a crawler on a tether, deployed vertically from the Space Station. The artificial gravity at any point along the tether is produced by the gravity gradient between that point and the station-tether system center of gravity, and is proportional to the distance between them. The lab could vary its gravity level, with a constant direction, by varying its distance from the system center of gravity. A constant gravity level could be maintained by adjusting the lab position to compensate for orbital variations in the system gravity level. The lab could also attain microgravity levels if it could move to the center of gravity. This lab could study processes with both gravity and time as variables. It has been calculated that the lab could attain g-levels of 10^{-6} , 10^{-4} , 10^{-2} , and 10^{-1} at distances above the center of gravity of about 2 m, 200 m, 20 km, and 200 km, respectively (see Figure A.6 of the Appendix).

In addition to easy gravity control, the use of a tether system for a low gravity lab would have other advantages. It would reduce disturbances transmitted to the lab (to about 10^{-8} g), minimize the gravity gradient acceleration inside the lab, and enhance overall system attitude control. It would have the disadvantage of reducing human access to lab experiments, requiring the increased use of remote controls. Also, it could only provide a gravity level of up to 10^{-1} g.

This lab could be used to examine the effects of low gravity on both physical and biological processes. Some biological processes of interest would be plant and animal growth, and human performance and medical processes (such as those related to the cardiovascular, skeletal, and vestibular systems). Such physical processes as crystal growth, fluid science, and chemical reactions could be studied. Conditions on low-gravity bodies (such as asteroids) could be simulated to examine natural processes (such as meteor impacts). Of particular interest would be the determination of the gravity threshold for various processes.

Comparisons of the reduced-gravity environments produced by tethered platforms and alternative facilities are presented in Figures A.8, A.9, and A.10 of the Appendix.

CONTACTS:

- o Kenneth Kroll
- o Paul Penzo

REFERENCES: 9 (pp. 223-238); 10 (pp. 53-77, 87, 125-147); 13 (pp. 64-66, 70-75, 78-80); 53

TETHERED SPACE ELEVATOR SS.05.00/AUGUST 1986

APPLICATION: The Space Elevator may be used as a Space Station facility in two ways: a microgravity facility to tap different levels of residual gravity, and a transportation facility to easily access tethered platforms.

DESCRIPTION: The Space Elevator is an element able to move along the tether in a controlled way by means of a suitable drive mechanism. The primary objectives of the microgravity elevator mission are the achievement of a new controllable microgravity environment and the full utilization of the Space Station support while avoiding the microgravity disturbances on board the Space Station. A short and slack cable could be used as both a power and data link.

A ballast mass represents the terminal end of the tether system. It could be any mass (e.g., a Shuttle ET) or a tethered platform. The objective of the transportation elevator application is to access large tethered platforms for maintenance, supply of consumables, or module and experiment exchanges.

CHARACTERISTICS:

- | | | | |
|-------------------|--|-----------------|----------|
| o LENGTH: | 10 km | o POTENTIAL FOR | |
| o ELEVATOR MASS: | 5,000 kg | TECHNOLOGY | |
| o BALLAST MASS: | Up to 50,000 kg | DEMONSTRATION: | Mid-Term |
| o g-LEVEL: | 10^{-7} to 10^{-3} | | |
| o POWER REQUIRED: | Up to 10 kW by tether power line link | | |
| o LINK DATA RATE: | Up to 20 Mb/s by tether optical fiber link | | |

CRITICAL ISSUES:

- o Space Station impacts
- o Dynamic noise induced on the tether
- o Design of a tether drive mechanism
- o Gravity-measuring instrumentation
- o Power link technology
- o Optical fibers link technology
- o Tether impact protection technology

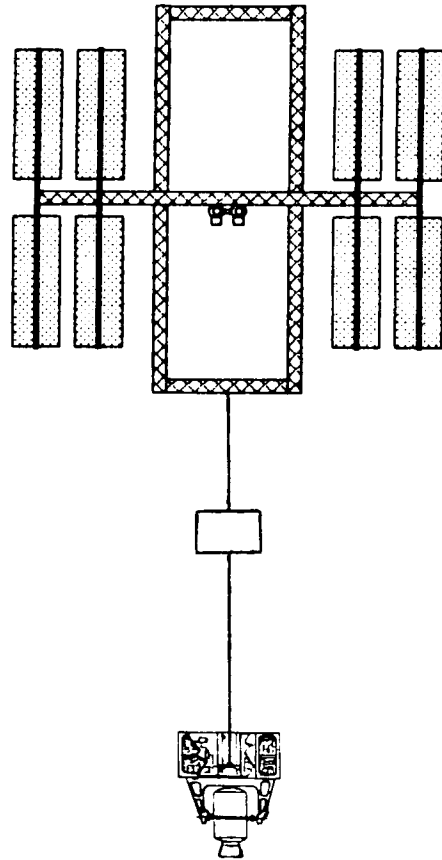

STATUS:

- o PSN/AERITALIA Elevator Definition Study in initial design assessment phase
- o Mid-term report issued (March 1986)
- o Final Report for the current study phase is expected in October 1986

DISCUSSION: The most promising feature offered by the Space Elevator is the unique capability to control with time the gravity acceleration level. In fact, since radial acceleration changes with position along the tether, the Elevator would be able to attain a continuous range and a desired profile vs. time of residual gravity level by the control of the Elevator motion. Moreover, the Elevator is able to fully utilize the Space Station support (power, communications, logistics) and to avoid the Space Station contaminated environment, from a microgravity point of view, by tether mediation.

Another way to exploit the Space Elevator capabilities is its utilization as a transportation facility. The idea of using large tethered platforms connected to the Space Station by power line and communication link (via tether technology) makes unrealistic frequent operations of deployment and retrieval. On the other hand, the platform may require easy access for maintenance, supply of consumables, module and experiment exchange. The Space Elevator, as a transportation facility able to move along the tether to and from the platform, may be the key to tethered platform evolution.

CONTACTS:

- o Franco Bevilacqua

REFERENCES: 10 (pp. 413-456); 17; 21; 35; 36; Applications SS.03.00, SS.04.00

ORIGINAL PAGE IS
OF POOR QUALITY

SHUTTLE DEORBIT FROM SPACE STATION
SS.06.00/AUGUST 1986

ORIGINAL PAGE IS
OF POOR QUALITY

APPLICATION: Allows the Shuttle orbiter to be deboosted to Earth while the Space Station is boosted to a higher orbit.

DESCRIPTION: Upon completion of a Shuttle re-supply operation to the Space Station, the Shuttle is deployed on a tether towards the Earth. The Space Station, accordingly, is raised into a higher orbit, causing excess momentum to be transferred from the Shuttle orbit to the Space Station orbit. After deployment, the Shuttle is released, causing the Shuttle to deorbit.

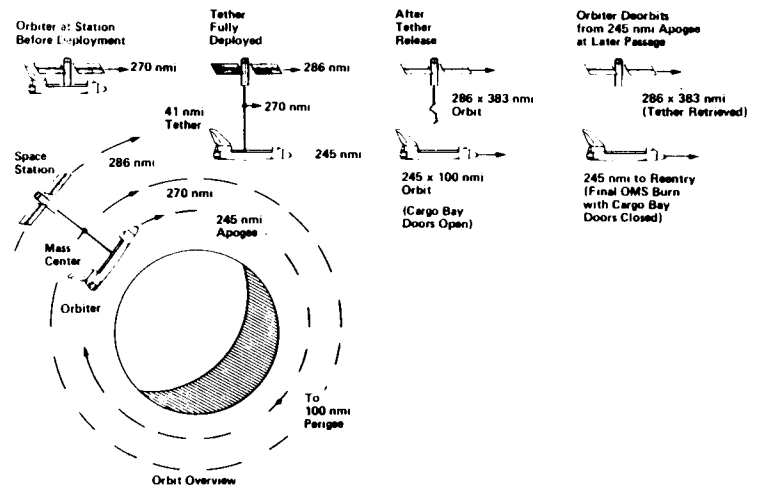

CHARACTERISTICS:

- o INITIAL SPACE STATION/SHUTTLE ORBIT: 500 km
- o TETHER LENGTH: 65 km
- o FINAL SPACE STATION ORBIT: 518 x 629 km
- o FINAL SHUTTLE ORBIT: 185 x 453 km
- o ESTIMATED MASSES: Space Station = 250,000 kg
Shuttle = 100,000 kg
- o POTENTIAL FOR TECHNOLOGY DEMONSTRATION: Mid-Term

CRITICAL ISSUES:

- o Excess angular momentum scavenged by Space Station must be used in order to beneficially use this application
- o Dynamic noise induced by tether deployment and separation
- o Alignment of tether to Space Station to eliminate torques

STATUS:

- o Martin Marietta, Selected Tether Applications Study, Phase III

DISCUSSION: This application could potentially be one of the most cost-effective uses of a tether. The main disadvantage is that the excess momentum transferred to the Space Station must be efficiently used, otherwise the Station will be in an orbit too high for subsequent Shuttle re-supply missions. Several ideas on use of this excess momentum have been looked at, such as alternating OTV boosts by the Space Station with Shuttle re-supply missions (see Application SS.07, Tethered OTV Launch). Another method is using an electrodynamic tether (see Application EL.01) to generate power at the expense of orbital energy to deboost the Space Station (see Appendix A.39 for diagram on annual propellant savings).

CONTACTS:

- o James K. Harrison
- o Georg von Tiesenhausen
- o Bill Woodis

REFERENCES: 10 (pp. 185-220, 239-268, 401-412); 13; 16

TETHERED OTV LAUNCH
SS.07.00/AUGUST 1986

APPLICATION: Allows an OTV to be boosted to a higher orbit at the expense of Space Station angular momentum.

DESCRIPTION: An OTV would be deployed from the Space Station on a tether away from the Earth, in preparation for launch. Upon separation from the tether, orbital angular momentum is transferred from the Space Station to the OTV, causing the Space Station altitude to be lowered while that of the OTV is raised.

CHARACTERISTICS:

- o INITIAL SPACE STATION/OTV ORBIT: 500 km
- o TETHER LENGTH: 150 km
- o FINAL SPACE STATION ORBIT: 377 x 483 km
- o FINAL OTV ORBIT: 633 x 1482 km
- o ESTIMATED MASSES: 250,000 kg (Space Station)
35,000 kg (OTV)
- o POTENTIAL FOR TECHNOLOGY DEMONSTRATION: Mid-Term

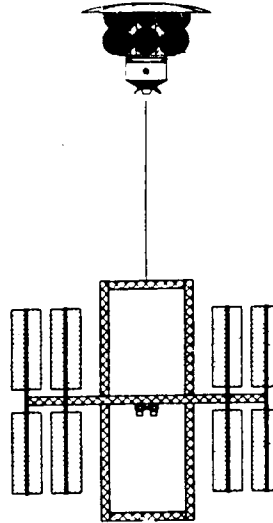

CRITICAL ISSUES:

- o Angular momentum taken away from the Space Station must be re-supplied in order to beneficially use this application
- o Dynamic noise induced by tether deployment and separation
- o Alignment of tether to Space Station to eliminate torques

STATUS:

- o Martin Marietta, Selected Tether Applications Study Phase III

DISCUSSION: Martin Marietta has studied the application of tethered deployment of the OTV as well as Shuttle from the Space Station. Either of these applications alone would cause an unacceptable change in altitude of the Space Station. When combined together, properly sequencing OTV launches and Shuttle deorbits, the orbital angular momentum of the Space Station may be preserved while providing a large net propellant savings for the Shuttle, OTV and Space Station (see Appendix A.39 for diagram on annual propellant savings).

CONTACTS:

- o James K. Harrison
- o Georg von Tiesenhausen

REFERENCES: 10 (pp. 185-220, 239-268, 401-412); 13; 16; Application SS.06

**HELIOCENTRIC ALFVEN ENGINE FOR INTERPLANETARY TRANSPORTATION
PA.01.00/AUGUST 1986**

APPLICATION: Generation of propulsion for interplanetary travel by using the electromagnetic interaction of a conducting tether and the interplanetary magnetic field.

DESCRIPTION: An insulated conducting tether, connected to a spacecraft and terminated at both ends by plasma contactors, provides interplanetary propulsion in two ways. The current induced in the tether by the solar wind magnetic field is used to power ion thrusters. The interaction between the tether current and the magnetic field can also be used to produce thrust or drag.

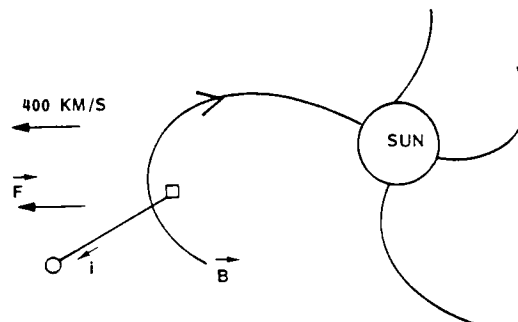

CHARACTERISTICS:

- | | | | |
|------------------|-----------------------------|-----------------------------|--------------|
| o TETHER LENGTH: | 1000 km | o COOLING: | Helium (2°K) |
| o CURRENT: | 1000 A | o POTENTIAL FOR TECHNOLOGY: | |
| o POWER: | 2 MW | o DEMONSTRATION: | Far-Term |
| o MATERIALS: | Superconducting Niobium-Tin | | |

CRITICAL ISSUES:

- o How does this system compare with others, such as nuclear or solar sail
- o Feasibility and controllability have not been established

STATUS:

- o TSS-1, demonstrating electromagnetic applications, is scheduled for a 1988-89 launch
- o More detailed study and evaluation of this application are required

DISCUSSION: The solar wind is a magnetized plasma that spirals outward from the sun with a radial velocity of about 400 km/sec. The magnetic field of the solar wind is 5×10^{-5} Gauss, producing an electric field of 2 V/km, as seen by an interplanetary spacecraft. If a conducting tether, connected to the spacecraft and terminated at both ends by plasma contactors, were aligned with the electric field, the emf induced in it could yield an electric current. This current could be used to power ion thrusters for propulsion. The current could be maximized by using superconducting materials for the tether. (This system was proposed by Hannes Alfvén in 1972.) It has been calculated that a 1000 km superconducting wire of niobium-tin could generate 1000 A (2 MW). To achieve superconduction temperatures, this wire could be housed in an aluminum tube with flowing supercooled (2° K) helium. The tube would be insulated and capped at each end with a refrigeration system.

In addition to the ion thrusters, the interaction of the tether current and solar wind magnetic field would produce thrust or drag. As current flowed in the tether, the magnetic field would exert an $\vec{I} \times \vec{B}$ force on the tether. If the spacecraft were moving away from the sun (with the solar wind), a propulsive force would be exerted on the tether as its electrical power was dissipated. A drag would be exerted on the tether if current from an on-board power supply were fed into it against the induced emf. When moving toward the sun (against the solar wind), the opposite conditions would apply.

This system could be used to spiral away from or toward the sun, or to move out of the ecliptic. Theoretically, such a spacecraft could attain the solar wind velocity of 400 km/sec. Use of the electromagnetic interaction between a conducting tether system and the solar wind may allow much shorter transfer times and larger payloads for planetary missions.

CONTACTS:

- o Paul Penzo
- o Nobie Stone
- o Richard Taylor

REFERENCES: 5 (pp. 4-11 through 4-22); 6 (pp. 5-11 through 5-29); 9 (pp. 127-151); 52

ELECTROMAGNETIC DECELERATION FOR PLANETARY CAPTURE
PA.02.00/AUGUST 1986

APPLICATION: Generation of a decelerating force on a spacecraft to allow planetary capture.

DESCRIPTION: A spacecraft constructed as two halves connected by an insulated conducting tether. Plasma contactors are used at both tether ends. Upon entering the magnetosphere of a planet with a strong magnetic field, the halves separate and deploy the tether, which conducts a large current between them. This produces a decelerating force on the spacecraft, slowing it for planetary capture. Upon capture, the halves rejoin for orbital operations.

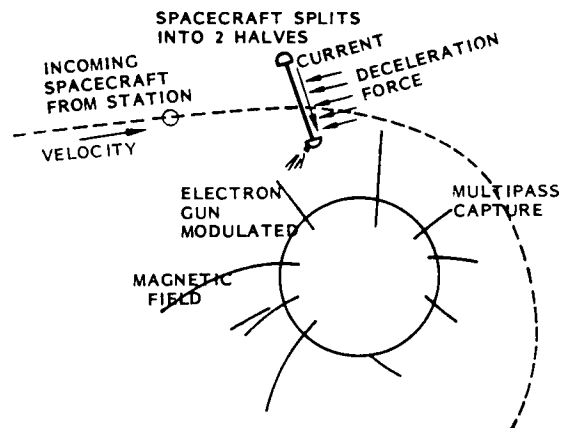

CHARACTERISTICS:

- o PHYSICAL CHARACTERISTICS: Undetermined
- o POTENTIAL FOR TECHNOLOGY DEMONSTRATION: Far-Term

CRITICAL ISSUES:

- o Further study is required to determine if sufficient braking thrust can be generated to allow capture during one encounter

STATUS:

- o TSS-1, demonstrating electromagnetic applications, is scheduled for a 1988-89 launch
- o No detailed evaluation of this application has been performed

DISCUSSION: Such a system has the advantage of a lower weight than the rockets and fuel required for braking. However, if the tether cannot produce all of the required deceleration, assistance would be required from another propulsion source. This system would also require a lower insertion accuracy than an aerobraking process. If the system uses a modulative electron gun, super-power radio transmission would be available during capture. The energy from braking could be dissipated as heat in the plasma or tether, as well as being radiated as RF waves. The major disadvantage is that such a system would only be applicable to the outer planets with magnetic fields. This technology may provide a valuable tool for the exploration of these planets.

CONTACTS:

- o Nobie Stone
- o Richard Taylor

REFERENCES: 5 (pp. 4-11 through 4-22); 6 (pp. 5-11 through 5-29)

**JUPITER INNER MAGNETOSPHERIC MANEUVERING VEHICLE
PA.03.00/AUGUST 1986**

APPLICATION: Generation of electromagnetic thrust or drag for maneuvering within the inner Jovian magnetosphere.

DESCRIPTION: An insulated conducting tether connected to a spacecraft and possibly terminated with a subsatellite. Plasma contactors are used at both tether ends. When used selectively with an on-board power supply (probably nuclear) or a load, it interacts with the Jovian magnetic field to produce thrust, drag and electrical power, as required to change orbital altitude or inclination.

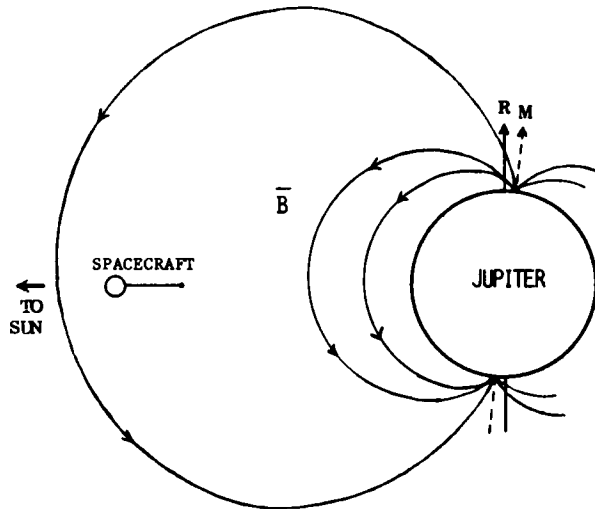

CHARACTERISTICS:

- o PHYSICAL CHARACTERISTICS: Undetermined
- o POTENTIAL FOR TECHNOLOGY DEMONSTRATION: Far-Term

CRITICAL ISSUES:

- o Successful operation of hollow cathodes or related active collectors as plasma contactors
- o Assurance of long-term insulator life
- o Susceptibility to micrometeoroid/debris damage
- o Successful operation of a power supply (probably nuclear) with sufficient output power density
- o Characterization of the performance of an electromagnetic tether in the Jovian magnetosphere

STATUS:

- o TSS-1, demonstrating electromagnetic applications, is scheduled for a 1988-89 launch
- o No detailed system design study for this application has been performed

DISCUSSION: Since Jupiter's magnetic field is about twenty times that of Earth, an electromagnetic tether should work well there. Because of Jupiter's rapid rotation (period = 10 hours), at distances greater than 2.2 Jovian radii from its center, the Jovian magnetic field rotates faster than would a satellite in a circular Jovian orbit. At these distances, the magnetic field would induce an emf across a conducting tether, and the dissipation of power from the tether would produce a thrust (not a drag) on the spacecraft/tether system. At lesser distances, the satellite would rotate faster than the magnetic field, and dissipation of tether power would produce drag (not thrust).

Examples of induced tether voltages are: -10 kV/km (for drag) in LJO; and +108, 50, 21, and 7 V/km (for thrust) at Io, Europa, Ganymede, and Callisto, respectively.

Inside the Jovian magnetosphere, at distances > 2.2 Jovian radii, the spacecraft could decrease altitude (decelerate) by feeding power from an on-board power supply into the tether against the induced emf. Below 2.2 radii, power from the tether could be dissipated. To return to higher altitudes, the process could be reversed.

Since the gravitational attraction of Jupiter is so strong, the energy required to descend to (or climb from) a very low Jupiter orbit is prohibitive for any conventional propulsion system. To descend to the surface of Jupiter from a distance of, say, 100 Jovian radii, an energy density of a little over 200 kW-hr/kg would be required for propulsion. Using this as a conservative estimate of the required performance of a tether system, it should be well within the capability of a nuclear power supply.

Recommendations were made at the Tether Workshop in Venice (October 1985) for a Jupiter inner magnetospheric survey platform to operate in the range from one to six Jovian radii. The electromagnetic tether in this application would be used primarily for orbital maneuvering. It could also assist a Galileo-type satellite tour (all equatorial), sampling of the Jovian atmosphere, and rendezvous with a Galilean satellite.

CONTACTS:

- o Paul Penzo
- o James McCoy

REFERENCES: 9 (pp. 127-151, 161-184, 369-377)

**TETHERED LUNAR SATELLITE FOR REMOTE SENSING
PA.04.00/AUGUST 1986**

APPLICATION: Provide instrument access to low, unstable, lunar orbital altitudes.

DESCRIPTION: An instrument package at low altitude, suspended by a tether from a satellite in a higher, stable, polar orbit around the Moon.

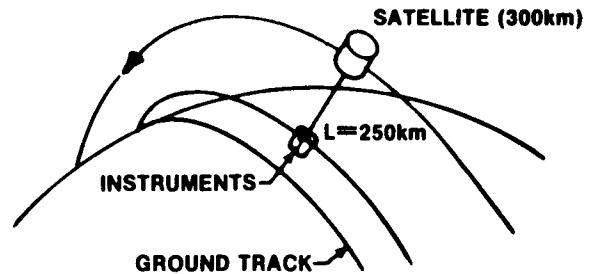

CHARACTERISTICS:

- | | | |
|------------------------|--------|---|
| o LENGTH: | 250 km | |
| o INSTRUMENT ALTITUDE: | 50 km | o POTENTIAL FOR TECHNOLOGY DEMONSTRATION: |
| o SATELLITE ALTITUDE: | 300 km | Far-Term |

CRITICAL ISSUES:

- o Assurance of acceptable strength and flexibility for the tether material
- o Susceptibility to micrometeoroid/debris damage

STATUS:

- o No detailed study on this application has been performed

DISCUSSION: Due to Sun and Earth perturbations, close lunar satellites would be unstable and short-lived (perhaps a few months). However, as proposed by Guiseppe Colombo, access to low lunar orbits could be achieved by tethering an instrument package to a satellite in a stable lunar orbit. The package could be lowered as close to the Moon as desired. One proposed configuration would tether an instrument package 50 km above the lunar surface from a satellite in a stable 300 km orbit. By using a polar orbit, complete coverage of the lunar surface could be obtained. Occasional adjustments to the tether length may be required to keep the package at a safe altitude. Sensitive measurements of such things as the Moon's magnetic field and gravitational anomalies could be made.

CONTACTS:

- o Paul Penzo

REFERENCES: 9 (pp. 127-151)

**LUNAR EQUATOR SURFACE SLING
PA.05.00/AUGUST 1986**

APPLICATION: Injection of material from the lunar surface into lunar orbit by using a sling.

DESCRIPTION: A sling on the lunar surface, carrying two payloads (one at each tip), would impart the momentum stored in its rotation (and derived from an external source such as solar energy) to the payloads for orbital insertion.

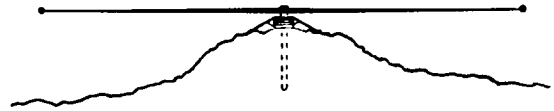

CHARACTERISTICS:

- | | | | |
|---------------------|---------------|-----------------|----------|
| o PAYLOAD: | 10 kg | o POTENTIAL FOR | |
| o LENGTH: | 1000 m | TECHNOLOGY | |
| o ROTATIONAL SPEED: | 16 rpm | DEMONSTRATION: | Far-Term |
| o LAUNCH RATE: | 1,000 tons/yr | | |

CRITICAL ISSUES:

- o Collision and debris generation may be major problems

STATUS:

- o No detailed evaluation of this application has been performed

DISCUSSION: This system would send material (probably moonrocks) from the lunar surface into lunar orbit without using propellants. The sling would use energy from an external source (solar energy for example) to build up rotational momentum. It would impart this momentum to each of two payloads (one at each tip), propelling them into lunar orbit. A 1000 m tether, rotating at 16 rpm and carrying a 10 kg payload at each tip, could launch a payload every 5 minutes. This amounts to 1,000 tons per year. The orbit would be short-lived (about 1 month).

An Earth-Moon tether transport system (see PA.06.00) could transport this material to Earth. Once a certain amount of material was in orbit, it could be collected by a Lunar Orbiting Tether Station (LOTS). Half of this material would be loaded into an Aerobraking Ferry Vehicle (AFV), deployed on a tether, spun-up, and released into transearth injection. The other half would be ejected back to the Moon to recover the momentum lost by the LOTS. This would allow propellant-free transportation of lunar material to the Earth.

CONTACTS:

- o Joe Carroll

REFERENCES: 9 (pp. 127-151); Application PA.06.00

PRECEDING PAGE BLANK NOT FILMED

**EARTH-MOON TETHER TRANSPORT SYSTEM
PA.06.00/AUGUST 1986**

APPLICATION: Transportation of material from lunar to Earth orbit.

DESCRIPTION: Material (probably moonrocks) in lunar orbit is collected by the LOTS (Lunar Orbiting Tether Station), half is transferred to an AFV (Aerobraking Ferry Vehicle) which transports it to LEO, where it is transferred to the TAMPS (Tether And Materials Processing Station). The AFV then returns to the Moon for more lunar material.

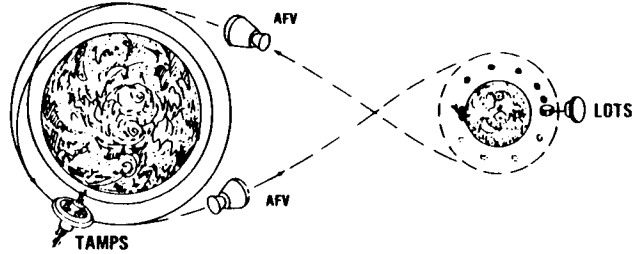

CHARACTERISTICS:

o PHYSICAL

CHARACTERISTICS: Undetermined

o POTENTIAL FOR TECHNOLOGY

DEMONSTRATION: Far-Term

CRITICAL ISSUES:

o Undetermined

STATUS:

o No detailed study on this application has been performed

DISCUSSION: Material (probably moonrocks) in lunar orbit could be transported to Earth orbit without the use of propellants with this tether transport system. [The material in lunar orbit could have been placed there by the Lunar Equator Surface Sling (see PA.05.00).] It could be collected in orbit by a Lunar Orbiting Tether Station (LOTS). The LOTS would proceed as follows: (1) catch the rocks, spin-up, catch an Aerobraking Ferry Vehicle (AFV); (2) load the AFV with half of the rocks; (3) spin-up, throw the AFV into transearth injection; (4) despin, load the other rocks on a tether; and (5) spin-up and deboost the rocks for momentum recovery.

The AFV would proceed to Earth, where it would aerobrake into LEO for capture by the Tether And Materials Processing Station (TAMPS). The TAMPS would proceed as follows: (1) catch, retrieve, and unload the aerobraked AFV; (2) process moonrocks into LO_2 , etc.; (3) refuel and reboost the AFV toward the Moon; (4) recover momentum with an electromagnetic tether; and (5) also capture, refuel, and reboost AFV's going to GEO and deep space when required. The AFV returning to the Moon would be rocket boosted into translunar injection and final lunar orbit for recapture by the LOTS.

CONTACTS:

o Joe Carroll

REFERENCES: 9 (pp. 127-151); Application PA.05.00

**MARS AERONOMY OBSERVER
PA.07.00/AUGUST 1986**

APPLICATION: Provide instrument access to low orbital altitudes for periodic in-situ analysis of the upper Martian atmosphere.

DESCRIPTION: An instrument package attached by a deployable 200 km tether to an orbiting Mars Observer spacecraft.

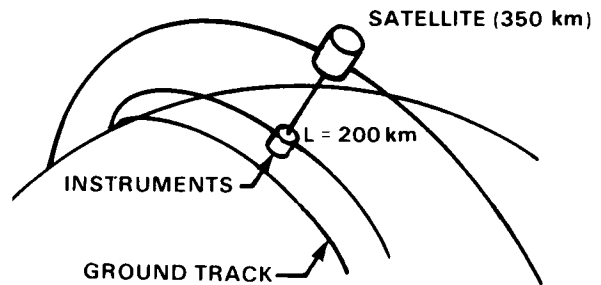

CHARACTERISTICS:

- | | | |
|------------------------|----------------|---|
| o LENGTH: | Up to 200 km | |
| o SATELLITE ALTITUDE: | 350 km | o POTENTIAL FOR TECHNOLOGY DEMONSTRATION: |
| o INSTRUMENT ALTITUDE: | Down to 150 km | Mid-Term |

CRITICAL ISSUES:

- o Undetermined

STATUS:

- o No detailed study or evaluation of this application has been performed

DISCUSSION: The Mars Aeronomy Observer (MAO) is included in NASA's Solar System Exploration Committee (SSEC) Core Program, and is planned to be launched in 1994 or 1996. This application of tether technology would serve to enhance the presently planned observer. The purpose of the mission itself is to analyze the composition and chemistry of the Martian atmosphere for one Martian year. The tether would allow instruments to be lowered periodically for in-situ measurements at lower altitudes. A 200 km tether could be used with the observer as it orbits Mars at an altitude of 350 km. The instrument package would be deployed for a few hours at a time, perhaps every two months, or so. Additional propulsion capability would be required for the observer for altitude maintenance. Although addition of the tether system would increase the mission cost, it should greatly enhance its scientific value.

CONTACTS:

- o Paul Penzo

REFERENCES: 9 (pp. 127-151)

PRECEDING PAGE BLANK NOT FILMED

ASTEROID GRAVITY ASSIST FOR MARS MISSIONS
PA.08.00/AUGUST 1986

APPLICATION: Production of an artificial gravity assist to aid Earth-Mars transfers by tethering the spacecraft to a near-Earth asteroid as it flies by.

DESCRIPTION: A tether system is used to change spacecraft direction as it travels between Earth and Mars, by attaching it to a near-Earth asteroid during fly-by, long enough for the spacecraft to swing around to the desired direction. Releasing the tether then allows it to proceed to its planetary rendezvous.

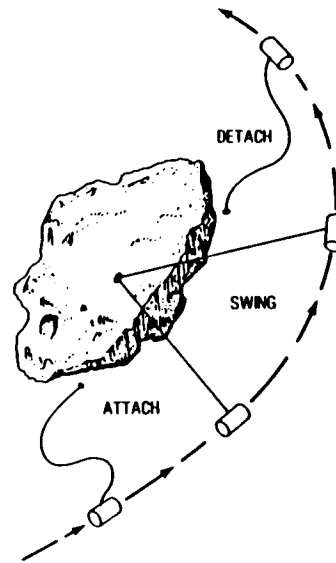

CHARACTERISTICS:

- | | | | |
|-------------|--------------|-----------------|----------|
| o LENGTH: | 1-2 km | o POTENTIAL FOR | |
| o STRENGTH: | 2-3 x Kevlar | TECHNOLOGY | |
| | | DEMONSTRATION: | Far-Term |

CRITICAL ISSUES:

- o Development of tether deployment, and asteroid attachment and release methods
- o Use of a tether material with a strength of 2-3 times that of Kevlar

STATUS:

- o No detailed study of this application has been performed

DISCUSSION: With the gravity assist technique, the gravity of a large body is used to accelerate a spacecraft, changing its direction of travel. This is very useful for interplanetary transfer because of the large fuel savings it permits.

This process can be simulated for Earth-Mars transfers by attaching an on-board tether to a near-Earth asteroid during a spacecraft fly-by, holding its length constant as the spacecraft swings around the asteroid, and then releasing it when the spacecraft is aligned with the desired flight path. Using this technique, the total transfer energy would not be required at launch--only the part required to reach the asteroid. The tethered fly-by would provide the necessary remainder. Only one or two kilometers of tether would be needed, but the necessary velocities would require a tether material two or three times stronger than Kevlar. Methods for deploying the tether and attaching it to the asteroid would have to be developed. Many asteroids, with diameters of about 1 km, are possible candidates. This means that transfer phasing

should not be a problem. The advantages of this technique for an Earth-Mars transfer are a possible 50% fuel savings, and a lower approach velocity at Mars.

CONTACTS:

o Paul Penzo

REFERENCES: 9 (pp. 127-151)

**ARTIFICIAL GRAVITY FOR EARTH-MARS TRANSFER VEHICLE
PA.09.00/AUGUST 1986**

APPLICATION: Generation of artificial gravity on board an Earth-Mars transfer vehicle.

DESCRIPTION: A tethered platform composed of two end structures, connected by a deployable/retractable 10 km tether. One end structure includes the solar arrays, related subsystems, and tether reel mechanism. The other includes two manned modules and a propellant motor. Artificial gravity is created in the manned modules by extending the tether and firing the motor, rotating the entire system about its center of mass (the solar panels are de-spun). Tether length is used to control the gravity level.

TETHER PLATFORM CONCEPT

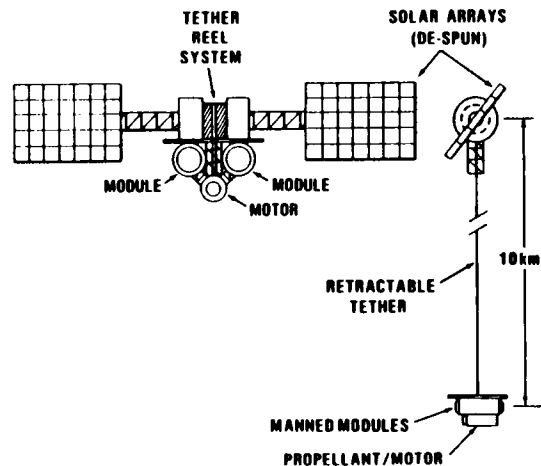

CHARACTERISTICS:

- | | | | |
|------------------|----------------|-----------------|----------|
| o LENGTH: | Up to 10 km | o POTENTIAL FOR | |
| o g-LEVEL: | Up to 1.25 | TECHNOLOGY | |
| o ROTATION RATE: | Up to 0.75 rpm | DEMONSTRATION: | Far-Term |

CRITICAL ISSUES:

- o Susceptibility to micrometeoroid/debris damage

STATUS:

- o No detailed system design study for this application has been performed

DISCUSSION: It may be determined that artificial gravity will be a physiological requirement on extended manned missions, such as to Mars. Artificial gravity (in the form of centrifugal acceleration) would be created by rotating the spacecraft. The magnitude of the resulting centrifugal acceleration is equal to the square of the angular velocity times the radius of rotation.

Two spacecraft configurations are likely possibilities--a rigid station-type and a tethered platform-type. The tether system has several advantages over the rigid one. It would provide a larger radius of rotation, reducing the rotational rate required to produce a desired g-level. This, in turn, would reduce unwanted side effects, such as the Coriolis force. The variable tether length would also allow a large variety of artificial gravity environments. To spin the system, the tether would be extended to its full 10 km length, and the motor fired. (The minimum necessary Delta-V has been calculated to be 125 m/s.) The tether length would then be adjusted to provide the desired g-level. Assuming the end

masses are equal and rotating about a common center, 0.08 g would result from a length of 10 km at a spin rate of 0.12 rpm, 0.16 g (lunar gravity) from a length of 8 km at 0.20 rpm, 0.38 g (Mars gravity) from a length of 6 km at 0.33 rpm, 1 g from a length of 4.30 km at 0.65 rpm, and 1.25 g from a length of 4 km at 0.75 rpm. The solar arrays would be de-spun and sun-oriented. However, a disadvantage is the high Delta-V required to start and stop this rotation.

Additional information on the acceptable values of artificial-gravity parameters is provided in Figure A.7 of the Appendix.

CONTACTS:

o Paul Penzo

REFERENCES: 9 (pp. 127-151); Application CG.01.00

**MARS SURFACE/ESCAPE TETHER TRANSPORTATION SYSTEM
PA.10.00/AUGUST 1986**

APPLICATION: Transportation of payloads between a 400 km low Mars orbit and an escape trajectory from Mars.

DESCRIPTION: A payload, tethered 375 km upward from a spacecraft in a 400 km Mars orbit, is released to rise successively to downward and upward tethers at Phobos, to downward and upward tethers at Deimos, and finally to an escape trajectory from Mars. This system also works in reverse.

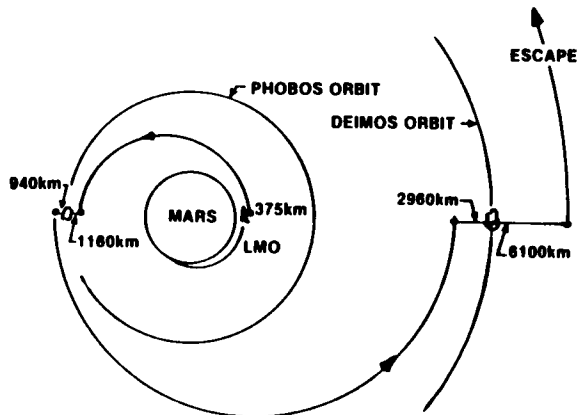

CHARACTERISTICS:

- | | | | |
|---------------------|--------------|----------------------------|----------|
| o LENGTH AT PHOBOS: | 1160 km Down | o POTENTIAL FOR TECHNOLOGY | |
| o LENGTH AT DEIMOS: | 940 km Up | DEMONSTRATION: | Far-Term |
| | 2960 km Down | | |
| | 6100 km Up | | |

CRITICAL ISSUES:

- o Development of methods for system construction and maintenance
- o Susceptibility to micrometeoroid/debris damage

STATUS:

- o No detailed system design study for this application has been performed

DISCUSSION: When released, a payload tethered 375 km above a spacecraft in a 400 km low Mars orbit (LMO) would rise to an altitude 1160 km below Phobos, and have the proper velocity to rendezvous with the downward tether from Phobos. It would then climb the tether, transfer to the other side of Phobos, and climb the 940 km tether. Upon release, it would rise to a rendezvous with the downward tether from Deimos. After transfer to, and release from, the tip of the upper tether on Deimos, it would escape from Mars. Moved in this way, a payload could be transferred from LMO to an escape trajectory, using propellant for only corrections and rendezvous. This system could also be used in reverse.

Kevlar strength is adequate for these tethers. One with a diameter of 3-4 mm is strong enough to handle 20,000 kg payloads. The ratio of tether mass to payload mass would range from 0.3 to 5. The main advantage of the system is that it would use the momentum of Mars satellites rather than propellant for payload transfer. It could also handle heavy traffic.

CONTACTS:

- o Paul Penzo

REFERENCES: 9 (pp. 127-151)

**COMET/ASTEROID SAMPLE RETURN
PA.11.00/AUGUST 1986**

APPLICATION: Collection and return to Earth of comet or asteroid samples.

DESCRIPTION: Tethered penetrators are launched from a spacecraft during its rendezvous with a comet or asteroid. They penetrate the body's surface, collecting samples of surface material. They are then reeled aboard the spacecraft for return to Earth. Using several penetrators, samples could be collected from different spots on one body, or from more than one body.

CHARACTERISTICS:

- | | | |
|----------------------|---------------------------|--|
| o TETHER LENGTH: | 50-100 m | |
| o TETHER SYSTEM: | Single Reel | |
| o PENETRATOR SYSTEM: | Multiple-Chambered Turret | |
| o PENETRATORS: | Core Drilling and Surface | |
| o DEPLOYMENT: | Spring and Solid Rocket | o POTENTIAL FOR TECHNOLOGY DEMONSTRATION: Far-Term |

CRITICAL ISSUES:

- o Long-range, remote-controlled maneuvering and rendezvous
- o Design and development of the penetrators, tether-reel subsystem, and penetrator turret subsystem

STATUS:

- o Although preliminary definition of the mission and hardware has been performed, detailed study and design remain to be done

DISCUSSION: The conventional approach to collecting samples from comets and asteroids would be for a spacecraft to rendezvous with them and release a lander. The lander would attach itself to the body in some way, drill for a core sample, and return to the spacecraft. The sample would then be returned to Earth. A typical scenario would require the following capabilities: (1) close range verification of a suitable landing and drilling site; (2) automated and highly accurate soft landing; (3) lander attachment to the body (since small bodies would have very low gravity); (4) a drill unit with sufficient power to core a sample; (5) lander separation from the body; (6) automated rendezvous with the orbiter; (7) sample transfer; (8) launch stage ejection; and (9) Earth return.

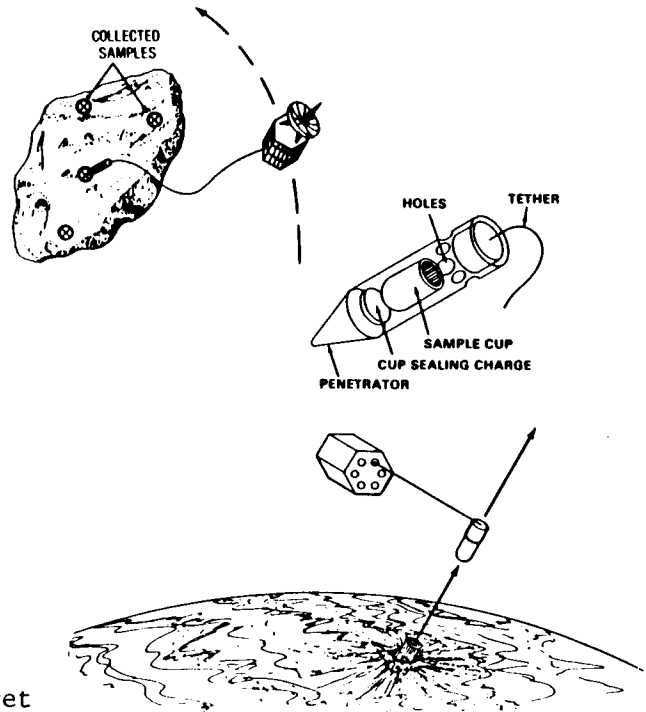

A tether approach would consist of the following sequence of events: (1) the spacecraft rendezvous with the comet or asteroid; (2) a tethered penetrator is shot at the target from a 50-100 m altitude; (3) on impact, sample material enters holes in the penetrator shell and fills the sample cut inside; (4) an explosive seals the cup and ejects it from the penetrator shell; (5) the cup velocity creates a tension in the tether as it rotates it; (6) spacecraft thrusters control the cup retrieval as it is reeled aboard; (7) other tethered penetrators retrieve samples from other areas or bodies; and (8) the spacecraft returns the samples to Earth.

In addition to the penetrator design described above, another type, in which the penetrator contains a core drill, could also be used. For this version, flanges would be extended upon impact, to secure the penetrator shell to the surface while the core sample is being drilled. The surface hardness would determine which type to use. Both types could be launched from the spacecraft by a spring and then propelled by attached solid rockets to the impact point. (This should impart sufficient momentum to permit a good surface penetration.) To allow a single tether-reel subsystem to handle many penetrators, a rotatable turret with multiple, chambered penetrators could be used.

This tether system has the advantage of being simpler than a lander system (not requiring many of the capabilities listed for a lander system), and of allowing the collection of samples from more than one spot or body. The cost of such a tether mission has been estimated to be about \$750 M, as opposed to about \$1-2 B for a lander mission. However, the two methods are complementary, in that the lander provides a single very deep sample and the penetrator provides smaller samples from different areas or bodies.

CONTACTS:

o Paul Penzo

REFERENCES: 9 (pp. 127-151); 51

**MAIN BELT ASTEROID TOUR AND SAMPLE RETURN
PA.12.00/AUGUST 1986**

APPLICATION: A spacecraft mission into the main belt for multiple asteroid fly-bys and sample collections.

DESCRIPTION: A spacecraft combines two tether techniques to provide multiple asteroid fly-bys and sample collections. A tether system is used to change the spacecraft's trajectory by attaching it to an asteroid during fly-by, long enough for the spacecraft to swing around to the desired trajectory. Releasing the asteroid, the spacecraft then proceeds to the next asteroid. Penetrators are used with the tether system to collect surface samples during asteroid attachments. After asteroid releases, the samples are pulled aboard the spacecraft for eventual return to Earth.

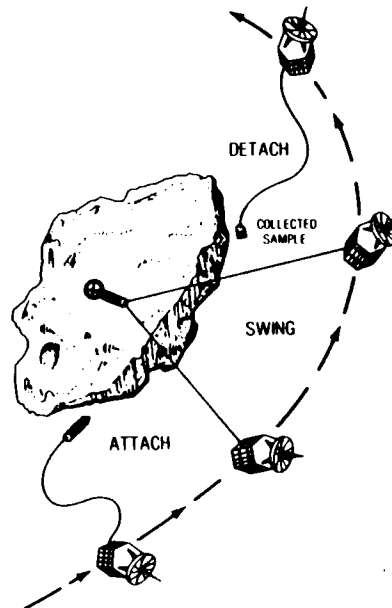

CHARACTERISTICS:

- o PHYSICAL CHARACTERISTICS: Undetermined
- o POTENTIAL FOR TECHNOLOGY DEMONSTRATION: Far-Term

CRITICAL ISSUES:

- o Undetermined

STATUS:

- o No detailed study of this application has been performed.

DISCUSSION: This mission would use a combination of two tether techniques (discussed in more detail in Applications PA.08.00 and PA.11.00). One technique would use tethers to produce artificial gravity assists for spacecraft trajectory changes. This would assist the spacecraft in making fly-bys of numerous asteroids in the main belt. The other technique would use tethered penetrators to collect surface samples from these asteroids. There are millions of small asteroids, which would provide many targets of opportunity. Optical sensors and laser ranging would allow accurate spacecraft maneuvering for the fly-bys. Many asteroid fly-bys could be made, and samples collected, during a long mission (say, 10 years), before returning the samples to Earth for study.

CONTACTS:

- o Paul Penzo

REFERENCES: 9 (pp. 127-151); Applications PA.08.00 and PA.11.00

TETHERED SUBSATELLITE STUDY OF SATURN'S RINGS
PA.13.00/AUGUST 1986

APPLICATION: Performance of a complete, close-range radial and azimuthal instrument scan of the Saturnian ring system.

DESCRIPTION: An instrumented subsatellite, tethered 500-1000 km from a main spacecraft, and 10-20 km above the Saturnian-ring plane. The main spacecraft utilizes constant-thrust propulsion to hover above the rings, as it spirals radially inward to the upper atmosphere of Saturn. Tethering the subsatellite provides it with an azimuthal orbital rate relative to the rings, permitting a complete azimuthal and radial scan of the ring system.

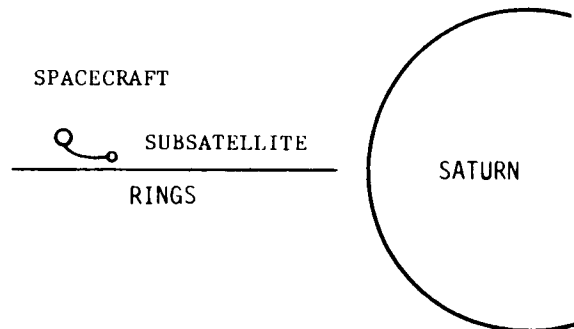

CHARACTERISTICS:

- | | | | |
|-------------------------|----------|---|------------------|
| o SUBSATELLITE MASS: | 500 kg | o 360° AZIMUTHAL SCAN TIMES: | 62 days (F-ring) |
| o FULL TETHER LENGTH: | 1000 km | | 42 days (spokes) |
| o ALTITUDE ABOVE RINGS: | 10-20 km | o POTENTIAL FOR TECHNOLOGY DEMONSTRATION: | Far-Term |
| o HOVERING PHASE: | 300 days | | |

CRITICAL ISSUES:

- o Determination of the minimum safe hovering altitude (upper bound on the diameter of embedded moonlets, likelihood of collisions if the hovering altitude is less than the radius of such moonlets, adequacy of the 10-20 km altitude to avoid collisions)
- o Determination of the imaging system's field of view, resolution, and need for image motion compensation
- o Determination of the effects on system dynamics/geometry of the tangential continuous-thrust component needed for inward spiraling

STATUS:

- o A preliminary study of mission and system-design parameters has been performed

DISCUSSION: A spacecraft could use continuous-thrust Nuclear Electric Propulsion (NEP) to hover above the rings, studying them at close range, as it spiraled inward toward Saturn. The NEP spacecraft alone, spiraling radially inward, would have the same orbital period as the ring particles directly below it. It would scan the rings only radially. However, with a tethered spacecraft system, the center of mass, not the individual components, of the system would co-orbit with the ring particles. A subsatellite at the end of a sufficiently long tether

would have an orbital angular rate significantly different from that of the ring particles directly below it, allowing both radial and azimuthal scanning. Orders of magnitude greater thrust would be required if only continuous thrust were used to achieve azimuthal scanning.

The deployed tether would follow a radial line through the center of Saturn, with the main spacecraft continuous-thrust propulsion producing a small component of the tether extension and tension perpendicular to the ring plane. Although this component of the tension would be small compared to the gravity gradient component (parallel to the ring plane), it would be sufficient to hold the subsatellite above the rings.

The subsatellite's orbital angular rate relative to the ring particles below it (the scan rate) would be proportional to the tether length. For a fixed length, the scan rate would increase very rapidly as the distance from Saturn decreased. Unfortunately, the tether tension would also increase. To accomplish a complete ring scan as fast as possible, the maximum tether length would be used. However, the maximum allowable tether tension (T^*) must not be exceeded. To optimize the scan rate, while not exceeding T^* , the following operational steps could be used: (1) the tether would be fully extended initially, as the spacecraft begins to spiral in toward Saturn; (2) it would remain fully extended until T^* was reached; and (3) a controlled tether retraction would begin to keep the tension at T^* for the rest of the mission. The maximum ring scan rate would occur at the radial distance from Saturn (R^*) at which T^* was reached with the tether fully extended. It would be possible to maximize the scan rate (minimize the 360° scan time) at a particular radial distance, corresponding to a particular ring feature of interest, by designing the system to reach R^* at that distance. In general, scan rates would be about $1^\circ/\text{sec}$ for a 10 km hovering altitude.

Calculations have shown that the component of tether extension perpendicular to the rings would have a nearly constant value of one-third of the subsatellite's altitude above the rings (Z) - independent of the tether length and distance from Saturn. For tether lengths of less than $Z/3$, extensions would be perpendicular to the ring plane. When the length exceeded $Z/3$, any increase in length would be parallel to the ring plane.

Calculations have shown that for a subsatellite mass of 500 kg, full tether length of 1000 km, and R^* of 120,000 km, the following would be expected: (1) a tether mass of 185 kg (with a safety factor of 3); (2) a tether volume of $93,000 \text{ cm}^3$; and (3) 360° azimuthal scan times of 62 days at the F-ring and 42 days in the vicinity of the spokes. These values seem quite reasonable. This system could complete 360° azimuthal scans in the regions of the F-ring and outer B-ring (site of the spokes) in about 100 of the total of about 300 days spent in the mission's hovering phase. If desired, a second subsatellite could be simultaneously deployed above the main spacecraft.

CONTACTS:

- o Larry Bright
- o Paul Penzo

REFERENCES: 50

ANCHORED LUNAR SATELLITE FOR TRANSPORTATION
PA.14.00/AUGUST 1986

APPLICATION: Transportation of material from the lunar surface to points throughout cislunar space, and from the two collinear lunar libration points to the lunar surface without rockets.

DESCRIPTION: A tapered tether, anchored to the lunar surface and extending through each of the two collinear lunar libration points. Each is balanced in tension about a libration point, and terminated by a counterweight. The tethers' lifting capacity is equal to their tensile force at the lunar surface. Payloads, carried from the lunar surface by motorized crawlers, are released from the libration points to drift to points throughout cislunar space. The system is operated in reverse to transport payloads from space to the surface.

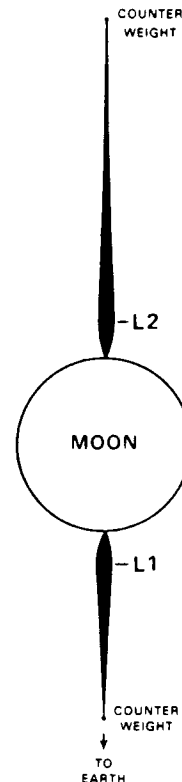

CHARACTERISTICS:

- | | |
|--|--------------------------|
| o SELF-BALANCED | o BASE LIFTING |
| TETHER LENGTH: 291,901 km (L1) | CAPACITY: 74,400 kg (L1, |
| 525,724 km (L2) | L2) |
| o BASE AREA: 10^{-4} m^2 (L1,L2) | o POTENTIAL FOR |
| o TETHER MASS: 5.31×10^8 kg (L1) | TECHNOLOGY |
| 9.00×10^8 kg (L2) | DEMONSTRATION: Far-Term |
| o MATERIAL: Graphite/Epoxy | |

CRITICAL ISSUES:

- o Susceptibility to micrometeoroid/debris damage
- o Development of construction hardware and techniques
- o Identification of convenient sources of materials for the tethers

STATUS:

- o A preliminary study of mission and system-design parameters has been performed

DISCUSSION: In the Earth-Moon system, there are five points in space which are equilibrium positions for a third body. A spacecraft or station could maintain its position at one of these libration points with a minimum of stationkeeping propellant. The two collinear libration points (L1, L2) closest to the Moon would provide excellent points around which to balance anchored satellites. Since the Moon has a captured rotation (one side always faces Earth), they could be built.

An anchored satellite would be basically a tether in tension, balanced about a lunar libration point and connected to the lunar surface. They could be made of existing engineering materials such as graphite/epoxy, boron/epoxy, Kevlar 49, or boron/aluminum (with graphite/epoxy being the most desirable). Their cross-sectional areas would be optimized by sizing them for a constant stress at all points along the tether. This would result in an exponential taper, with a maximum area at the libration point and minima at the ends. The taper ratio (the maximum area divided by the area at the lunar surface) for a graphite/epoxy tether would be less than 30 - the lowest of the candidate materials. However, the availability of carbon on the moon is uncertain, and an outside source might be required (such as carbonaceous chondrites). Aluminum and boron are much more common, but the taper ratio for boron/epoxy would be nearly 100, and more for boron/aluminum.

Tether construction would begin by launching a thin strand of material to L1 or L2 by rocket. It would be extended from a manned construction module to the lunar surface. The balancing portion of the tether could be extended upward to the balancing length and a counterweight attached to provide tension (equal to the product of the stress limit and the cross-sectional area at the lunar surface). The upper tether end could also be terminated far short of the balancing length by attaching a counterweight large enough to provide this tension. (This would increase the total mass, but reduce the required mass of high-strength material.) Once the strand was attached to the surface and put into tension, it could be traversed by a crawler, attaching additional strands to build it up to its final size. The net lifting capacity at the tether base would be equal to the net upward force on the base - the tether tension.

L1 is 58,021 km above the center of the Moon's near side, and L2 is 64,517 km above the center of the far side. Both points lie on a straight line drawn through the centers of the Earth and Moon. It has been calculated that for an anchored satellite to reach the lunar surface and be balanced by its own mass about L1, it would have to be 291,901 km long. An anchored satellite balanced about L2 would have to be 525,724 km long. It has been calculated that graphite/epoxy tethers with base areas of 10^{-4} m^2 would have a base lifting capacity of 74,400 kg, and masses of $5.31 \times 10^8 \text{ kg}$ (L1) and $9.00 \times 10^8 \text{ kg}$ (L2). Assuming that material could be carried to L1 at an average velocity of 375 m/s, $2.77 \times 10^8 \text{ kg}$ could be carried to L1 in one year.

Since L1 and L2 are unstable libration points, the tether would not stay in a stable orbit if it were severed near the base, even after jettisoning its counterweight. An emergency stabilization system would be required. It could be a powered module near the balance point lengthening or shortening the tether. Extra strands of material could be lowered along the tether to the lunar surface to repair the break.

Anchored satellites would use the Moon's rotational energy to launch orbital or escape payloads. A payload would be supplied with this energy by lifting it to the libration point (probably with electric crawlers). It could be released from there, or allowed to slide to higher points without additional energy before release. It has been

calculated that the L2 tether would require only 0.749 kW-hr/kg to transport payloads to L2. Upon release, a payload could drift to most points in cislunar space (roughly the disk-shaped space enclosing the five libration points of the Earth-Moon system). Since small changes in the velocity given to the payload at release would drastically change the area accessible to it, a large part of cislunar space (including Earth and lunar orbits) could be reached from L1 and L2, with very small velocities. Unfortunately, the two stable non-collinear libration points could not be reached without rockets. Therefore, it has been proposed to locate space colonies in an Earth orbit with a period of one-half month, where they would be easily accessible from L1 and L2. Various lunar equatorial orbits could be reached by releasing the payload below the libration point. Materials from the lunar surface could be put into lunar orbit, sent throughout cislunar space, or put into Earth orbit with these tethers. They could also be used in reverse to supply the lunar surface without using landing rockets.

CONTACTS:

- o Jerome Pearson
- o Paul Penzo

REFERENCES: 7

ANCHORED LUNAR SATELLITE FOR COMMUNICATION
PA.15.00/AUGUST 1986

APPLICATION: Provide nearly continuous satellite communications with the lunar farside without using stationkeeping propellants.

DESCRIPTION: A communications satellite in a halo orbit, attached to a tapered tether anchored to the lunar surface in the center of the farside. The tether, rotating about the farside lunar libration point (L2), acts as a passive position control system, with the system moving as a spherical pendulum. The cable is sized to maintain the satellite in balance with its tensile force. The halo orbit is large enough to keep the satellite in nearly continuous contact with Earth.

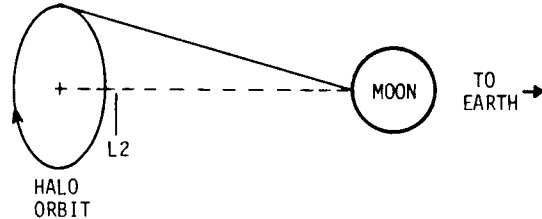

CHARACTERISTICS:

- o TETHER LENGTH: 68,056 km (Min.) o POTENTIAL FOR TECHNOLOGY DEMONSTRATION: Far-Term

CRITICAL ISSUES:

- o Susceptibility to micrometeoroid/debris damage
- o Development of construction hardware and techniques
- o Identification of convenient sources of materials for the tethers
- o Determination of the particular halo orbit to be used

STATUS:

- o A preliminary study of some mission and system-design parameters has been performed

DISCUSSION: The anchored L2 lunar satellite described in Application PA.14.00 could also be used as a communications link between the lunar farside and the Earth. The tether would act as a completely passive position control system for an attached communications satellite. The tether would attach the satellite to the surface in the center of the farside. It would be sized to maintain the satellite in balance with its tensile force. The satellite would rotate in a lunar halo orbit large enough to keep it in essentially continuous contact with the Earth, or perhaps also with another anchored satellite at the L1 libration point.

For the satellite to maintain a tether tension and remain stable, the minimum tether length would be the distance from the surface to L2 when the Moon is at apogee (68,056 km). Calculations have shown that the satellite motion would be a complex Lissajous pattern. A typical tra-

jectory would have brief blackout periods of only about 11 hours in 65 days. If the satellite were put in a halo orbit at a near-minimum altitude of 70,000 km, the tether could be very small because of the near-zero force on it. Here the satellite mass could be thirty times that of the tether. For a satellite mass of a few thousand kilograms, a very thin wire would suffice, with a total mass of a few hundred kilograms.

CONTACTS:

- o Jerome Pearson
- o Paul Penzo

REFERENCES: 7; Application PA.14.00

SECTION 4

APPENDIX

Appendix

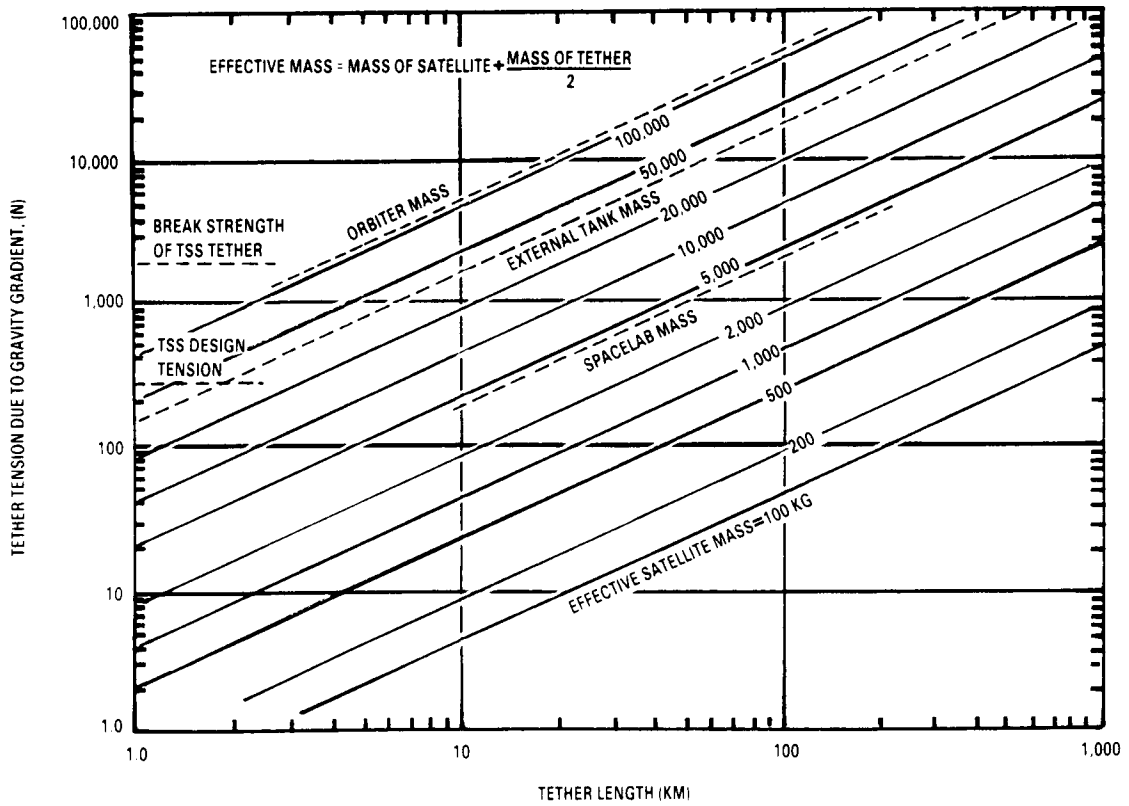

Figure A.1. Tether Tension Due to Gravity Gradient Versus Tether Length From Center of Gravity and Effective Satellite Mass in LEO [Ref. 5, pp. 3-7] Cited from p. 2-8.

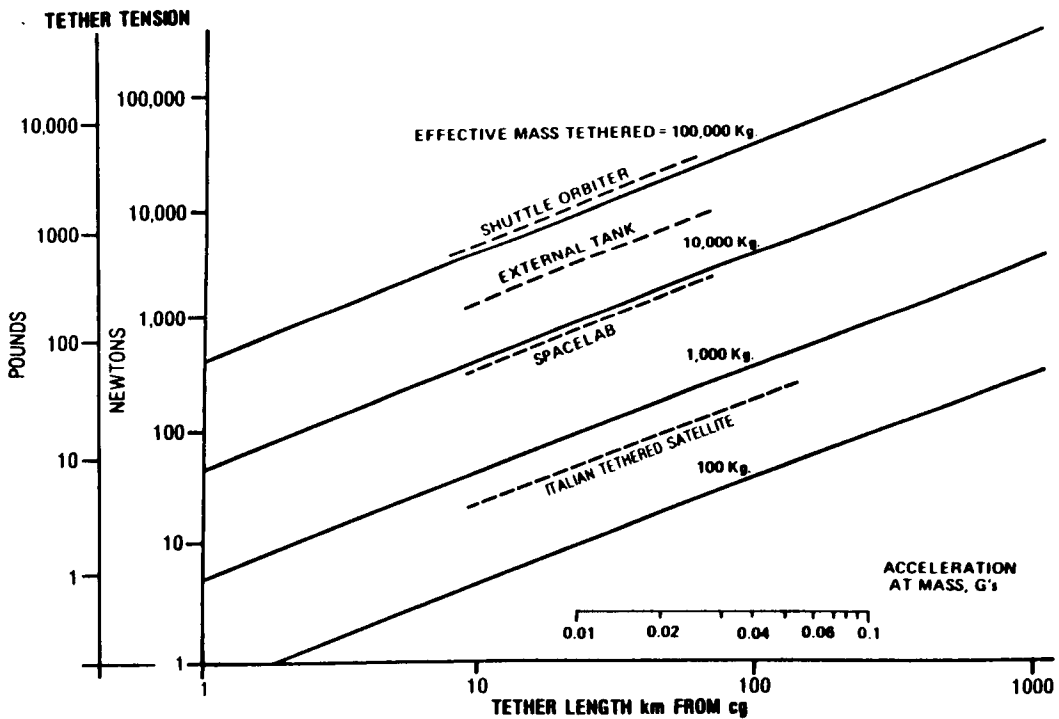

Figure A.2. "Artificial Gravity" at Tethered Masses in LEO [Ref. 5, pp. 1-20] Cited from p. 2-8.

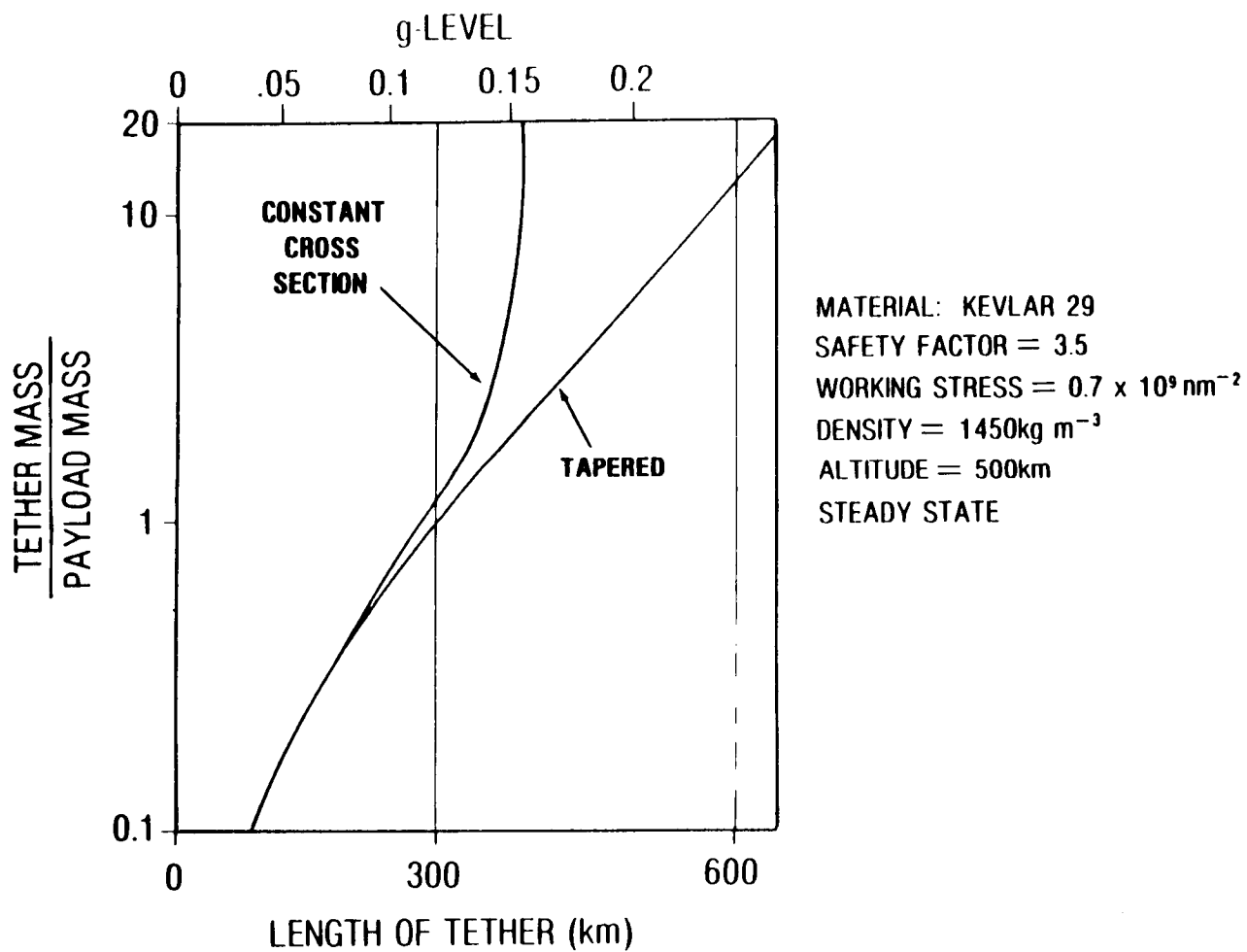
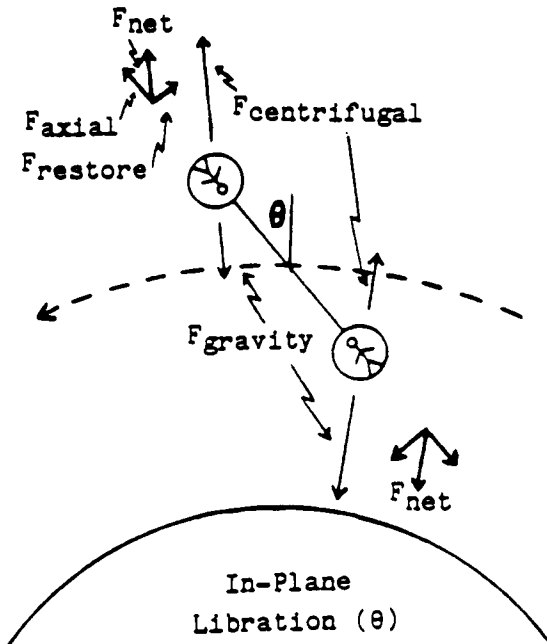

Figure A.3. Tether Mass And g-Level Versus Tether Length for Kevlar 29 Tethers [Ref. 10, p. 129] Cited from p. 2-8.



$$\ddot{\theta} \approx -3n^2 \sin\theta \cos\theta = -1.5n^2 \sin(2\theta)$$

$$\dot{\theta} \approx \pm \sqrt{3} n \sqrt{\sin^2 \theta_{\max} - \sin^2 \theta}$$

($\dot{\theta} \approx \pm \sqrt{3} n \sin \theta_{\max}$ when $\theta=0$)

$$n_{\theta} \approx n \sqrt{3 \cos \theta_{\max}}$$

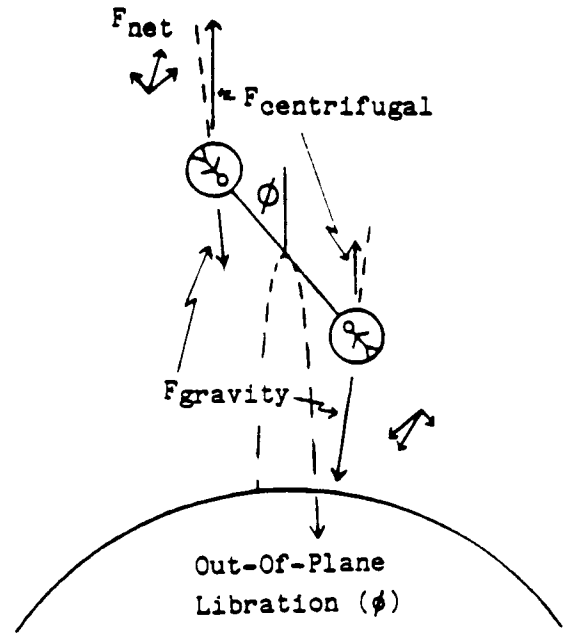

$$\ddot{\phi} \approx -4n^2 \sin\phi \cos\phi = -2n^2 \sin(2\phi)$$

$$\dot{\phi} \approx \pm 2n \sqrt{\sin^2 \phi_{\max} - \sin^2 \phi}$$

($\dot{\phi} \approx \pm 2n \sin \phi_{\max}$ when $\phi=0$)

$$n_{\phi} \approx 2n \sqrt{\cos \phi_{\max}}$$

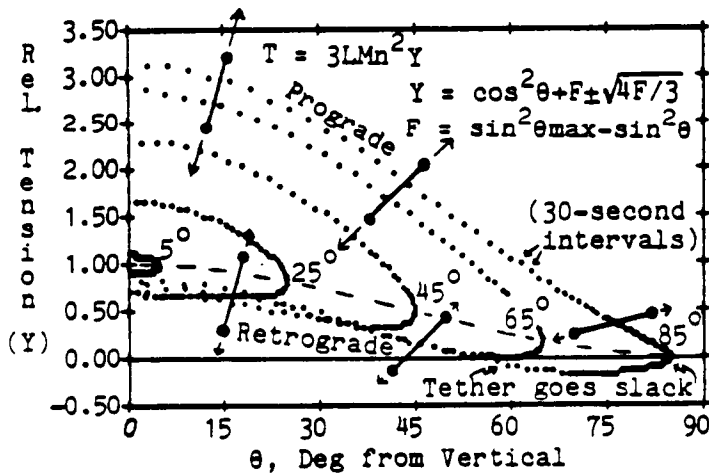

Tension Variations in Librating Dumbbells (compared to tension in hanging dumbbells)

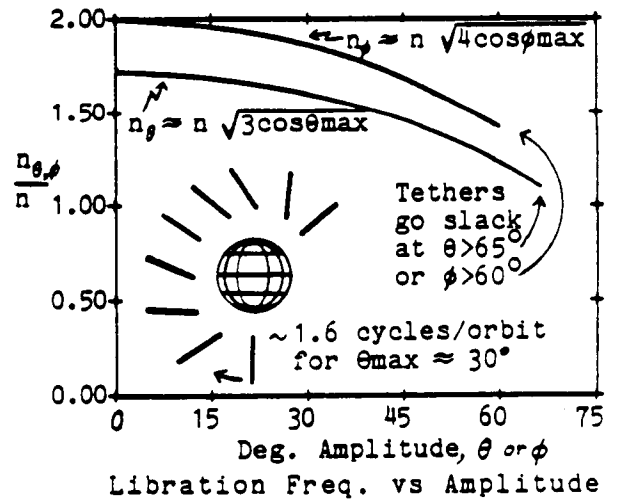
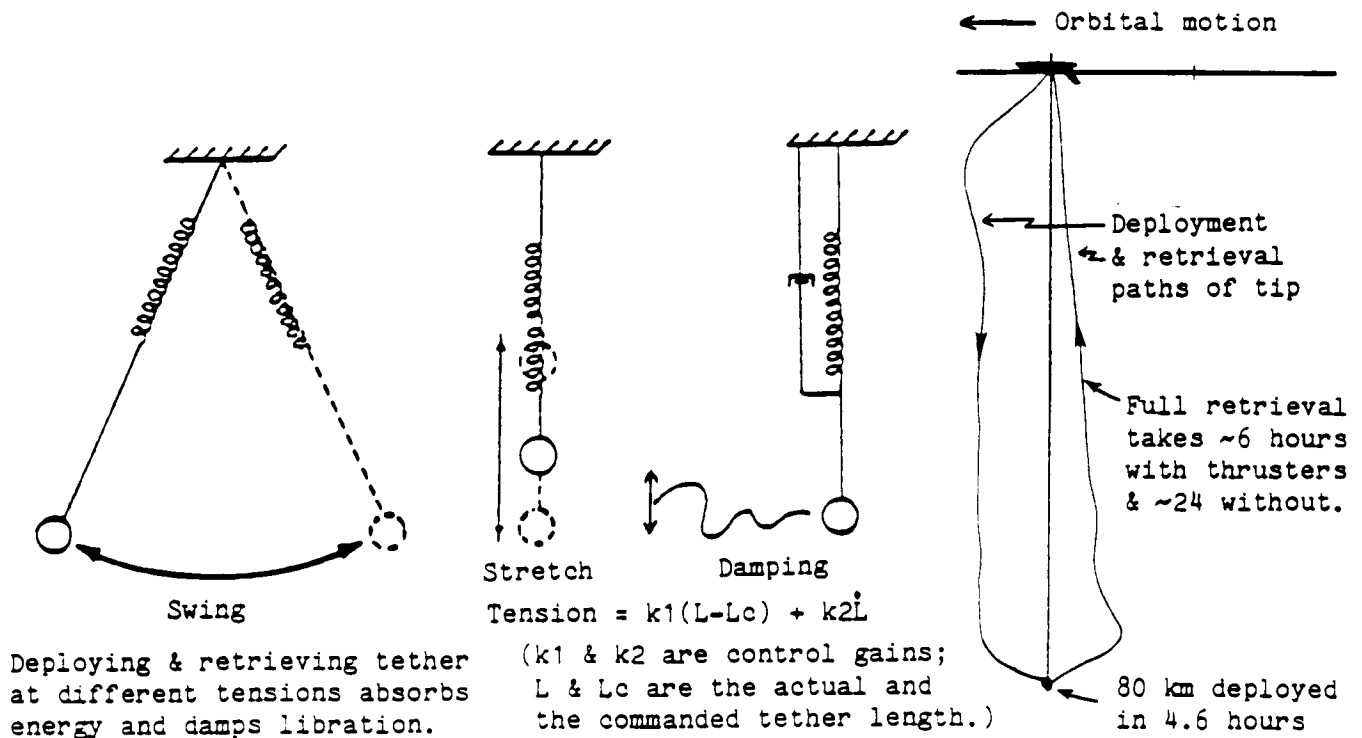

Figure A.4. Dumbbell Libration In Circular Orbit [Ref. 1, p. 15] Cited from p. 2-9.

EFFECTIVENESS OF VARIOUS CONTROL CONCEPTS

APPLICATION CONTROL OUTPUT	Libration		Tether Oscillations		Endmass Attitude Osc.	
	In-plane	Out-of-plane	Longitudinal	Transverse	Pitch & Roll	Yaw
Tension	Strong	Weak	Strong	Strong	Strong	None
	(Note: tension control is weak when tether is short)					
El. Thrust	Only if $M1 \neq M2$		None	Only odd harmonics	None	None
Thruster	Strong, but costly if prolonged			None	Strong, but costly if prolonged	
Movable mass	Good w/short tether		Possible but awkward		None	None
Stiff tether, Movable boom	Strong if tether is very short; weak otherwise					
Aerodynamic	High drag—use only if low altitude needed for other reasons.					



TENSION CONTROL FOR LIBRATION DAMPING... AND DEPLOYMENT/RETRIEVAL

Figure A.5. Tether Control Strategies
[Ref. 1, p. 17] Cited from p. 2-10.

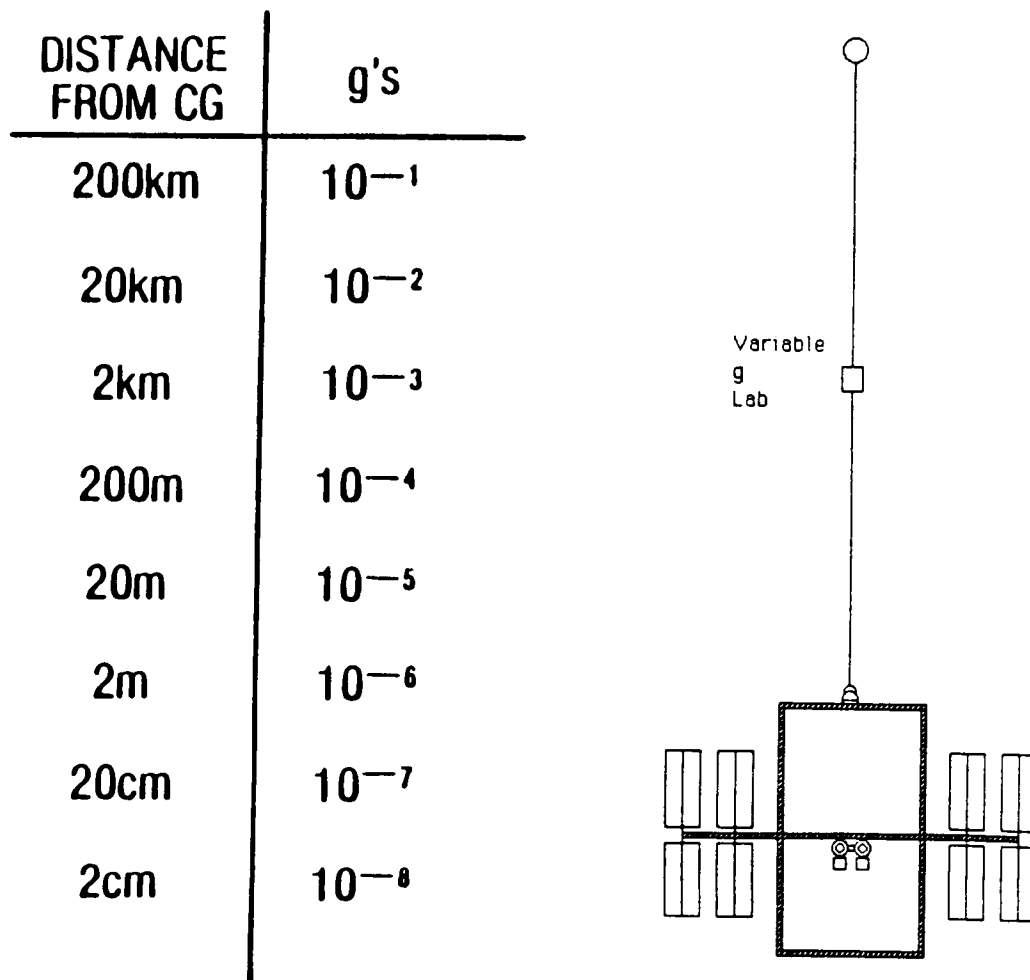

Figure A.6. Artificial-Gravity Level Versus Tether Distance From the Center of Gravity (Space Station Altitude) [Ref. 10 (p. 130); 53] Cited from p. 2-12.

ARTIFICIAL GRAVITY— PARAMETERS

- UNAIDED TRACTION REQUIRES 0.1 G
- ANGULAR VELOCITY SHOULD BE LESS THAN 3.0 RPM TO AVOID MOTION SICKNESS
- MAXIMAL CENTRIPETAL ACCELERATION NEED NOT EXCEED EARTH GRAVITY
- CORIOLIS ACCELERATION SHOULD NOT EXCEED 0.25 CENTRIPETAL ACCELERATION FOR A LINEAR VELOCITY OF 3 FEET/SECOND IN A RADIAL DIRECTION
- "G" GRADIENT SHOULD NOT EXCEED 0.01 G/FOOT IN RADIAL DIRECTION
- TETHER MASS MIGHT BE LIMITED TO 10,000 TO 20,000 POUNDS

ARTIFICIAL GRAVITY PARAMETERS

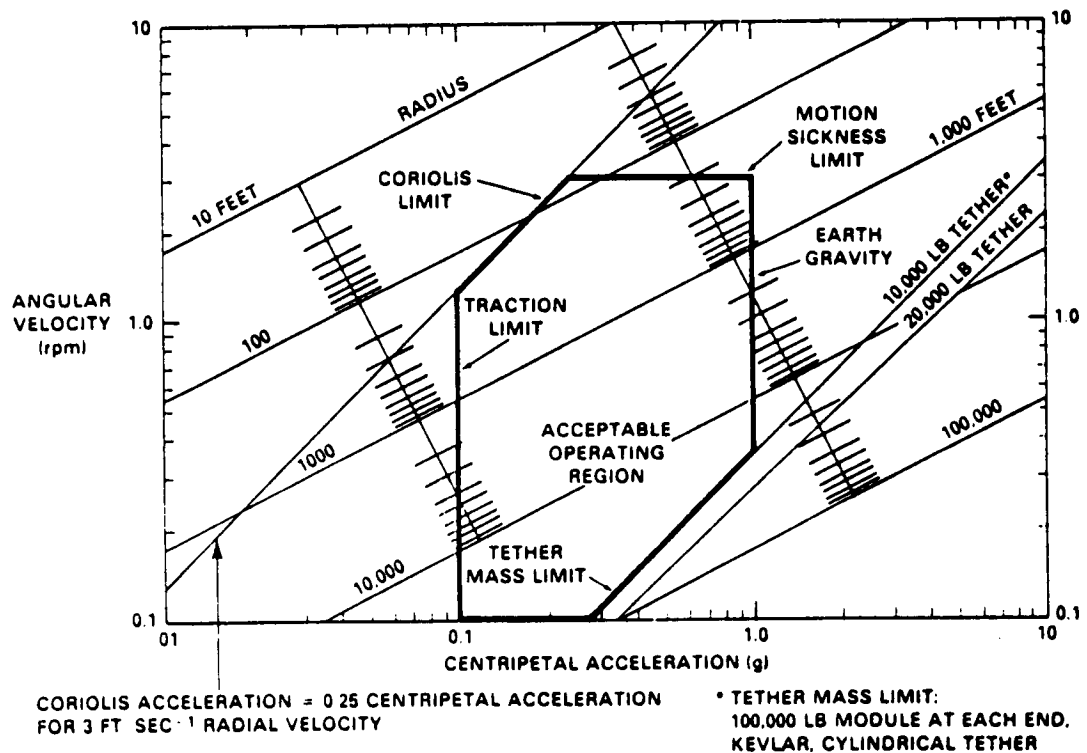

Figure A.7. Acceptable Values of Artificial-Gravity Parameters
[Ref. 5 , pp. 3-101] Cited from p. 2-13, Applications
PA.09, CG.01, CG.02.

ORIGINAL PAGE IS
OF POOR QUALITY

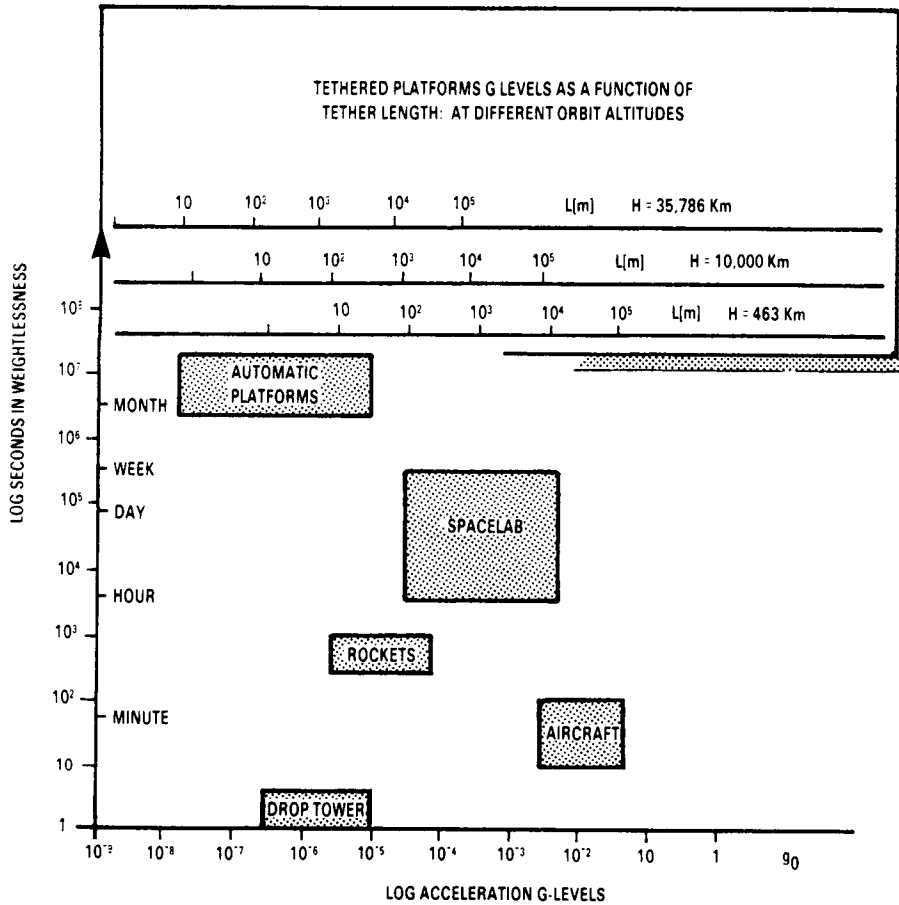

Figure A.8. Nominal Gravitational Levels as a Function of Durations Achievable with the Main Available Microgravity Platforms Compared with Tethered Platforms [Ref. 10, p. 70] Cited from p. 2-14, Applications SS.03, SS.04.

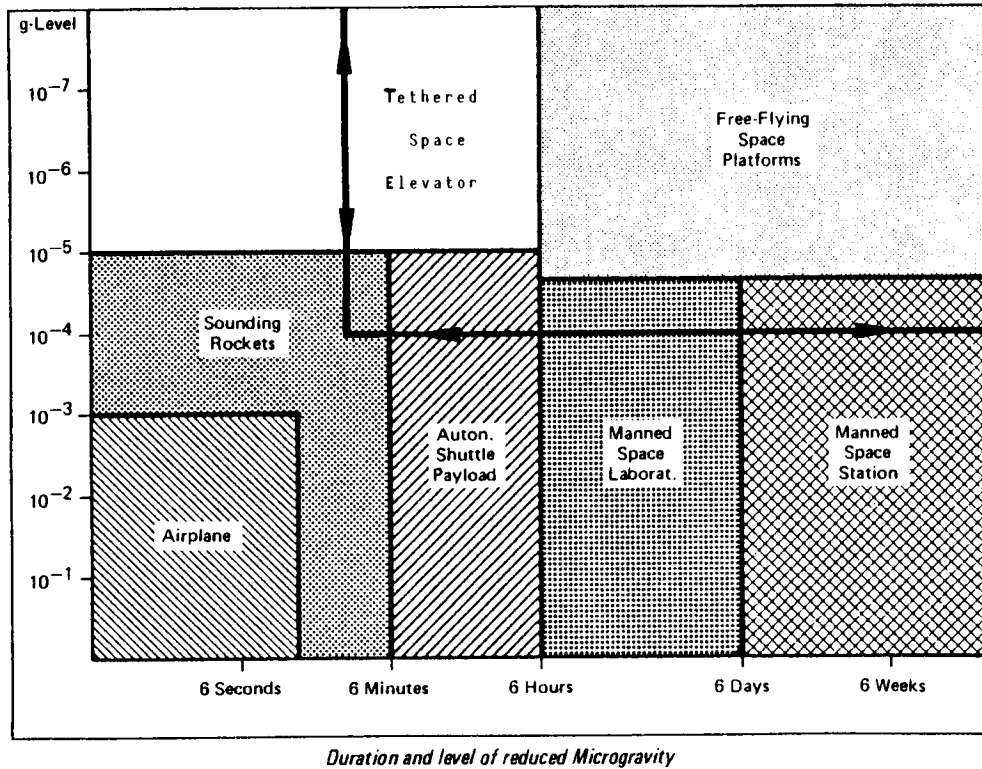

Figure A.9. Comparison of Various Microgravity Environments [Ref. 10, p. 418] Cited from p. 2-14, Applications SS.03, SS.04.

Microgravity Facility / Micro-G Environment	Free - Flying Space Platforms	Tethered Space Elevator
G-value	Single Point	Variable
Direction	Unknown	Known
Controllability Vs Time	NO	YES both in intensity and direction
G-Noise Control	NO	YES
G-Quality	Medium	High

Figure A.10. Comparison of Microgravity Environments for Free-Flying Platforms and Tethered Elevators [Ref. 10, p. 419] Cited from p. 2-14, Applications SS.03, SS.04.

Fluid Settling

- **SETTLING REQUIREMENT**
 - **GRAVITY DOMINATE SURFACE TENSION**
- **FLUID SETTLING PARAMETER IS BOND NUMBER (B_o)**

$$B_o = \frac{\rho * A * D^2}{4 * \sigma}$$

ρ = FLUID DENSITY
 σ = SURFACE TENSION COEFFICIENT
 D = TANK DIAMETER

- **FLUID SETTLES IF $B_o > 10$**
 - **$B_o = 50$ CHOSEN TO BE CONSERVATIVE**

PROPELLANT SETTLING ON A STATIC TETHER ($B_o = 50$)

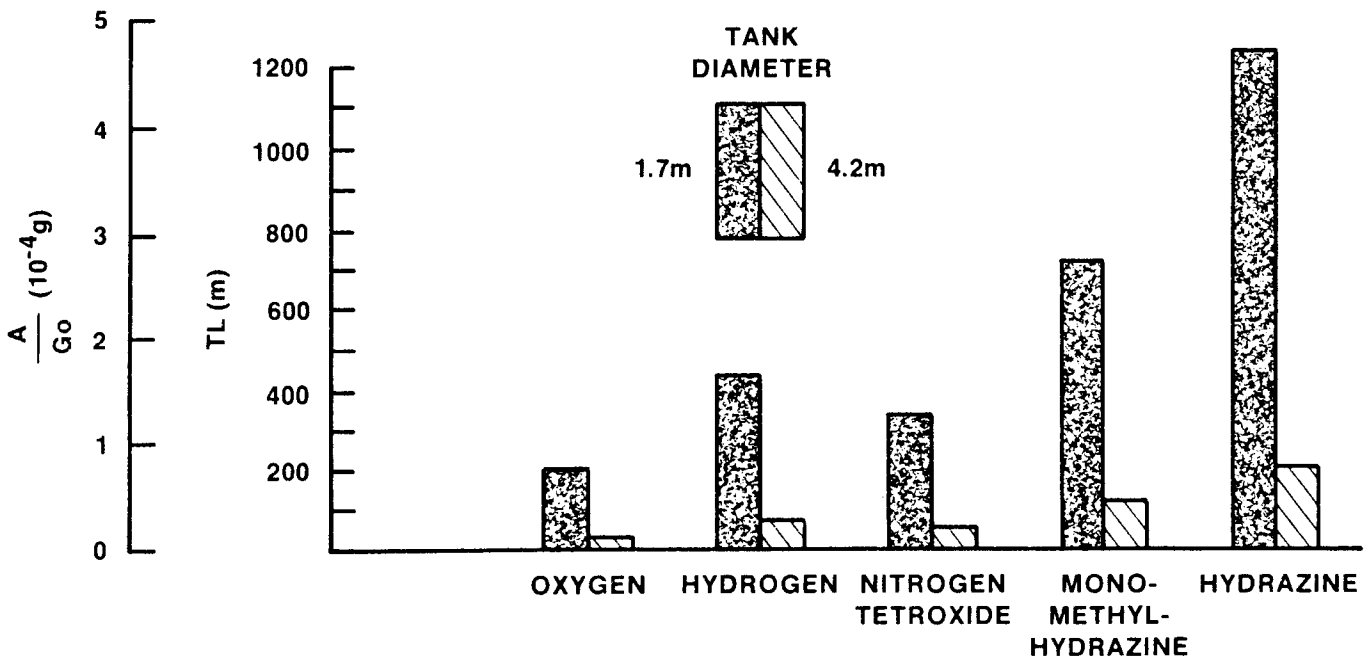

Figure A.11. Fluid Settling Properties of Various Liquid Propellants Under Conditions of Artificial Gravity - Required Tether Length Versus Propellant [Ref. 9, p. 230] Cited from p. 2-14, Applications SS.01, SS.02.

• STABILITY CONDITION WHEN NEGLECTING THE TETHER DRAG CONTRIBUTION IS GIVEN BY:

$$\frac{1}{6} \rho \frac{a^2}{l} C_D \left(\frac{A_2}{m_2} - \frac{A_1}{m_1} \right) > 1$$

• THE SYSTEM DECAY BY:

$$\frac{da}{dt} = 2 C_D \frac{A_2 + A_1}{m_1 + m_2} \rho \sqrt{\mu a}$$

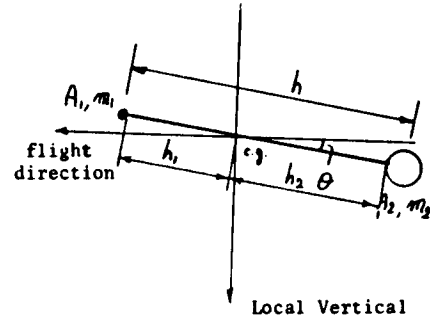

• STABILITY AND SYSTEM LIFETIME, WITHOUT REBOOSTING, ARE CONTRASTING REQUIREMENTS

• MAXIMUM HORIZONTAL TETHER LENGTH ACHIEVABLE STRONGLY LIMITED BY TECHNOLOGICALLY ATTAINABLE A/M RATIO OF THE BALLOON (MAXIMUM A/M = 10 : 20 M²/KG)

Figure A.12. Dynamics and Stability of a Horizontal Tether With A Downstream Balloon [Ref. 9 (p. 300) and 10 (p. 169)] Cited from p. 2-17.

DRAG STABILIZATION LIMITS FOR SINGLE-AXIS HORIZONTAL CONSTELLATIONS

$$\text{AREA/MASS} = A/M_2 = 10 \text{ M}^2/\text{KG}$$

z (km)	Minimum Atmo. Density Exospheric Temp. = 600K		Maximum Atmo. Density Exospheric Temp. = 1100K	
	h _{max} (m)*	da/dt (km/day)**	h _{max} (m)	da/dt (km/day)
150.	2.31x10 ⁵	2.84x10 ³	3.23x10 ⁵	3.97x10 ³
200.	1.89x10 ⁴	2.29x10 ²	4.79x10 ⁴	5.82x10 ²
300.	5.47x10 ²	7.05	4.51x10 ³	5.36x10 ¹
400.	3.57x10 ¹	0.42	7.58x10 ²	8.80
500.	3.64	0.04	1.61x10 ²	1.83

*h_{max} = maximum horizontal length for stable configuration

**da/dt = orbital decay rate

Figure A.13. Drag Stabilization Limits for Single-Axis Horizontal Constellations [Ref. 10, p. 170] Cited from p. 2-17.

ORIGINAL "FISH-BONE" CONFIGURATION STABILITY ANALYSIS

*STABILITY CONDITION, WHEN NEGLECTING THE HORIZONTAL TETHER DRAG CONTRIBUTION, IS:

$$\frac{1}{6} \rho \frac{a^2}{h} C_D \left(\frac{3A_2 + dt_2 \ell_2}{M_2} - \frac{3A_1 + dt_1 \ell_1}{M_1} \right) > 1$$

-TETHER A/M RATIO INCREASES BY DECREASING ITS THICKNESS BUT IT IS NEVERTHELESS SMALL WHEN COMPARED TO THE BALLOONS.

-THE NECESSITY OF A MASSIVE DEPLOYER SYSTEM AT MASS M_{22} STRONGLY REDUCES THE MAXIMUM A/M RATIO OF THE DOWNSTREAM VERTICAL TETHER SUBSYSTEM.

*CONCLUSIONS

-THE "FISH-BONE" CONSTELLATION, WITHOUT ANY MODIFICATIONS, HAS A STABILITY (MAXIMUM ALLOWABLE HORIZONTAL TETHER LENGTH) LOWER THAN THE SINGLE AXIS HORIZONTAL CONSTELLATION.

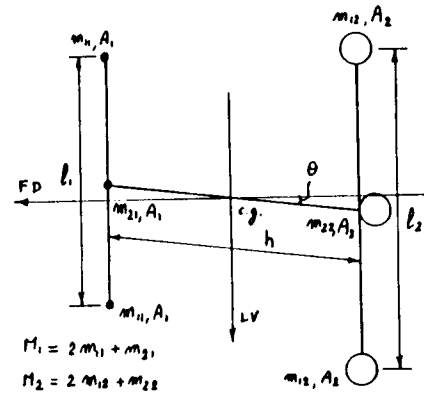

Figure A.14. Original "Fish-Bone" Configuration Stability Analysis [Ref. 10, p. 171] Cited from p. 2-18.

*ASSUMPTIONS

$$\ell_2 = \ell_1 = 20 \text{ km}$$

$$A_2/m_{12} = 10 \text{ m}^2/\text{kg} ; A_1/m_{11} = 4 \times 10^{-3} \text{ m}^2/\text{kg}$$

$$dt_2 = 1 \text{ mm (kevlar)} ; dt_1 = 2 \text{ mm (kevlar)}$$

$$m_{11} = m_{12} = 200 \text{ kg}$$

$$m_{21} = 1000 \text{ kg} ; m_{22} = 800 \text{ kg (deployer)} + 200 \text{ kg (balloon)} = 1000 \text{ kg}$$

z (km)	Minimum Atmo. Density Exospheric Temp. = 600K		Maximum Atmo. Density Exospheric Temp. = 1100K	
	h_{\max} (m)*	$\frac{da}{dt}$ (km/day)**	h_{\max} (m)	$\frac{da}{dt}$ (km/day)
150.	9.54×10^4	5.99×10^4	1.33×10^5	8.38×10^4
200.	7.81×10^3	4.83×10^3	1.98×10^4	1.23×10^4
300.	2.26×10^2	1.49×10^2	1.86×10^3	1.13×10^3
400.	1.47×10^1	8.87	3.13×10^2	1.86×10^2
500.	1.50	0.84	6.65×10^1	3.86×10^1

* h_{\max} = maximum horizontal length for a stable configuration

** $\frac{da}{dt}$ = orbital decay rate

Figure A.15. Stability Limits for a "Fish-Bone" Constellations Vs. Orbital Altitude [Ref. 10, p. 172] Cited from p. 2-18.

*ASSUMPTIONS

Orbit Altitude = 500 km; $m_{tot} = 4 \times 5000 \text{ kg} = 20 \text{ metric tons}$; $h/l = 0.5$; Near Equatorial Orbit.

*T = Tension in the horizontal tethers

**Orbit decay rate computed for average atmo. density.

*DSC WITH HORIZONTAL TETHER DIA. = .2 mm.

*T(N)	$T/3\rho\Omega^2$	Min. Atmo. Density Exosp. Temp. = 600K dia. balloon (m)	Aver. Atmo. Density Exosp. Temp. = 800K dia. balloon (m)	Max. Atmo. Density Exosp. Temp. = 1100K dia. balloon (m)	** Orbital Decay (km/day)	h(km)	l(km)
0.02	1.21×10^8	137.92	51.78	20.72	0.62	9.	18.
0.04	2.42×10^8	195.05	73.22	29.31	1.25	14.	28.
0.06	3.63×10^8	238.88	89.68	35.90	1.87	23.5	47.

*ESC (OPTION 1) ALL ALUMINUM TETHERS WITH THE SAME DIA.

*T(N)	V = Electro Motive Force (KV)	$\frac{B_1 V}{36\rho\Omega^2}$	h(km)	l(km)	Diameter Conductive Tether (mm)	Current (Amp)	Power (kw)	Solar Panel Area (m ²)	** Orbit Decay (km/day)
0.06	13.80	10×10^8	10	20	0.21	0.2	2.76	20.	1.61×10^{-2}
0.1					0.27	0.33	4.55	32.5	1.83×10^{-2}
0.2					0.38	0.67	9.23	66.0	2.39×10^{-2}
0.3					0.47	1.01	13.80	98.6	2.93×10^{-2}
0.4					0.57	1.41	19.99	149.9	3.55×10^{-2}
0.6					0.67	2.03	27.98	199.9	4.55×10^{-2}

Figure A.16. Design Parameters for DSC and ESC
[Ref. 10, p. 175] Cited from p. 2-19, 2-20.

*STABILITY ANALYSIS

- ASSUMPTIONS

ORBITAL ALTITUDE = 500 km

3-MASS 1000 kg EACH

BALLOON BALLISTIC COEFFICIENT = $10 \text{ m}^2/\text{kg}$

BALLOON DIA. = 100 m

*CONCLUSIONS

A SMALL PITCH ROTATION OF THE
CONSTELLATION MAKES ONE OF THE
INCLINED TETHERS GO SLACK.

Constellation Rotation (deg) that causes one of the inclined
tether to go slack, as a function of geometrical parameters

	0.3	0.5	0.7	1.0	h/l
h(km)					
5.	4°.42	2°.03	1°.39	0°.95	θ''
10.	2°.22	1°.01	0°.69	0°.47	θ''
15.	1°.48	0°.67	0°.46	0°.31	θ''

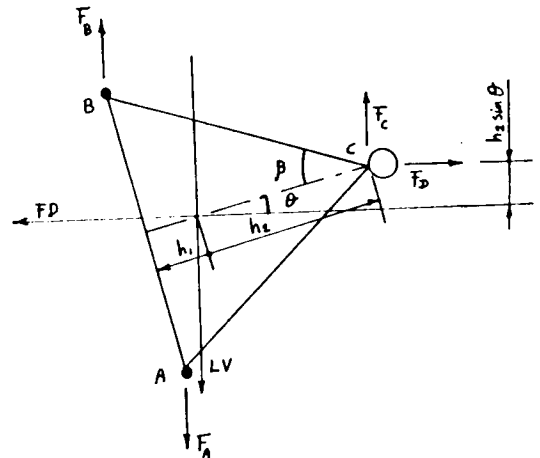

Figure A.17. Triangular Constellations Stabilized by an Air Drag
[Ref. 10, p. 178] Cited from p. 2-19.

*ESC (OPTION 2) HORIZONTAL WIRES ALUMINUM, VERTICAL WIRES COPPER

- COMPARATIVE TABLE

T(N)	I(Amp)	V(KV)	Power(KW)	Comments
0.3	1.01	13.8	13.8	All wire aluminum
		10.6	10.6	Horizontal Al + .38 mm dia. copper vertical
		7.6	7.6	Horizontal Al + .54 mm dia. copper vertical

*ESC (OPTION 3) HORIZONTAL WIRES KEVLAR VERTICAL WIRES COPPER

- FRONT VERTICAL WIRE AS ALFVEN ENGINE
- REAR VERTICAL WIRE AS POWER GENERATOR
- POWER TRANSFER (TRANSFER VOLTAGE 5kV, EFFICIENCY 90%)
- BIFILAR LINE TO DELIVER POWER MADE OF SAME COPPER WIRE

I(A)	T(N)	V _{delivered} (KV)	V(KV)	P(KW)	Comments
0.2	0.06	2.96	2.44	.49	•
0.33	0.1	2.54	3.06	1.02	•
0.67	0.2	1.71	4.89	3.26	•
1.0	0.3	1.07	6.53	6.53	•
0.2	0.06	3.32	1.58	.316	••
0.33	0.1	3.08	1.93	.643	••
0.67	0.2	2.54	3.06	2.04	••
1.0	0.3	2.17	3.93	3.93	••

*Vertical tether copper R = 30000 dia. = .38 mm

**Vertical tether copper R = 15000 dia. = .54 mm

Figure A.18. ESC Design Parameters [Ref. 10, p. 176]
Cited from p. 2-20.

*ASSUMPTIONS

- ALUMINUM WIRE DIA. = .67 mm
- THIS KIND OF STRUCTURE CAN BE USED AS EXTERNAL FRAME TO STABILIZE A LIGHT TWO-DIMENSIONAL STRUCTURE (e.g. A REFLECTOR)

	Current (Amp)	Voltage (kV)	T ₁ (N)	T ₂ (N)	Perimeter
Case 1					
h = 2a = 20 km					
l = 2b = 40 km	1.130	12.4	1.35	.56	96.88
Case 2					
h = 2a = 10 km					
l = 2b = 20 km	.565	3.10	.339	.141	48.44

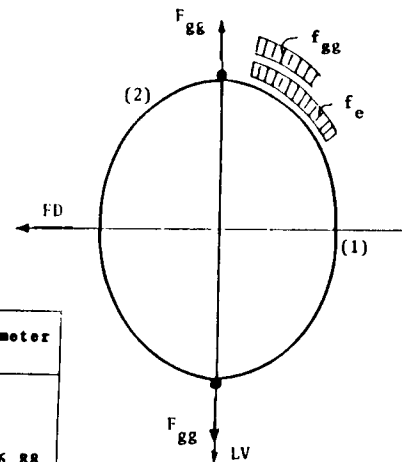

Figure A.19. Pseudo-Elliptical Constellation Electromagnetically Stabilized (PEC) [Ref. 10, p. 177] Cited from p. 2-20.

ORIGINAL PAGE IS
OF POOR QUALITY

Momentum Transfer

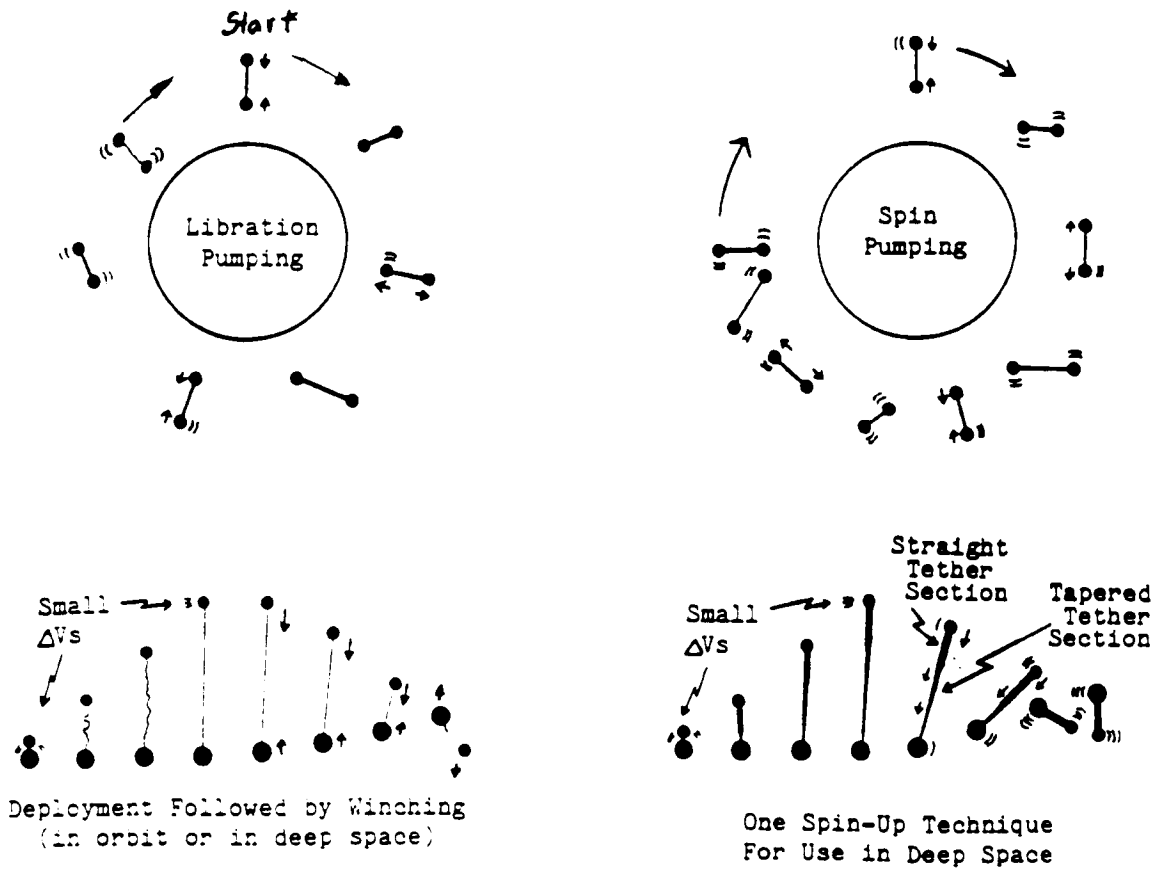
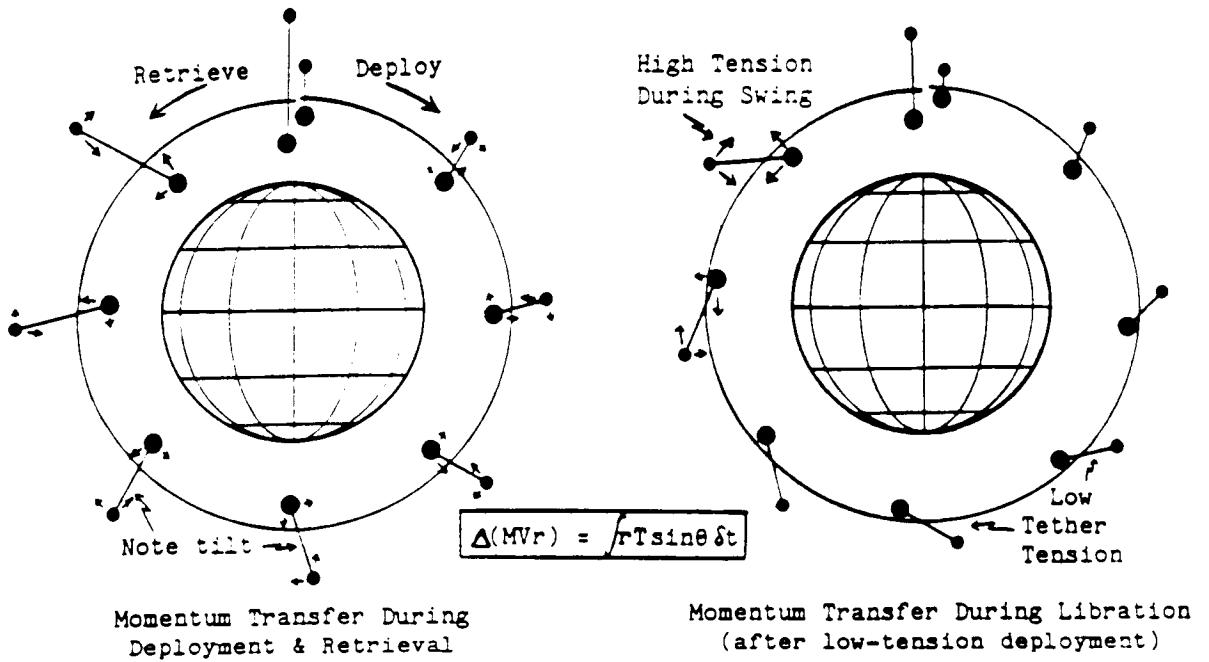
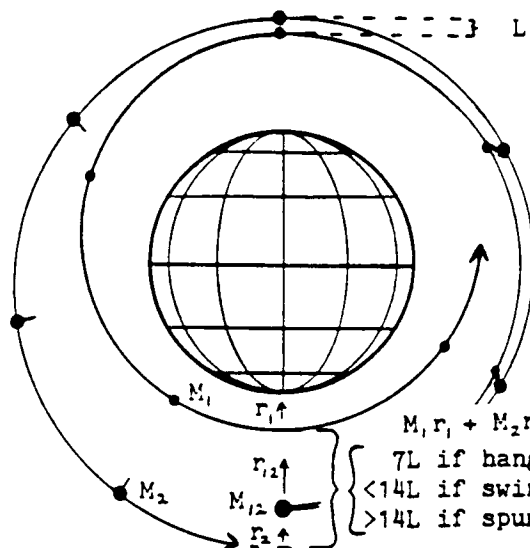
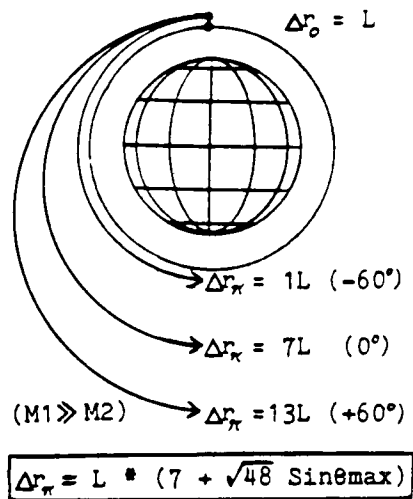

Figure A.20. Momentum Transfer [Ref. 1, p. 19]
Cited from pp. 2-25, 2-27, 2-28.

ORIGINAL PAGE IS
OF POOR QUALITY



Effects of Tether Deployment and Release



Effect of Libration on Boost
(release at middle of swing)

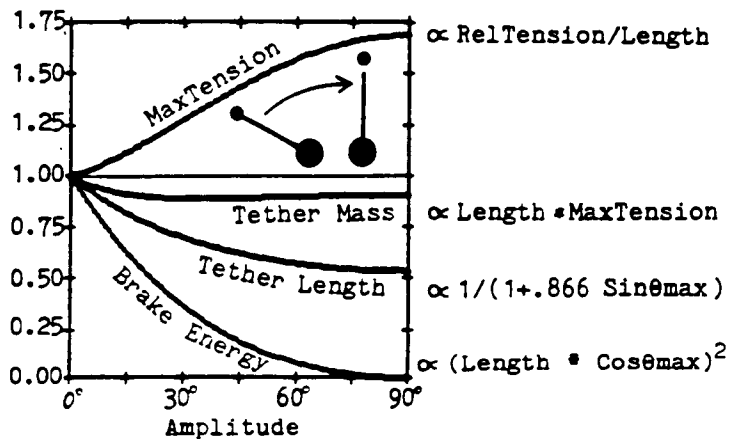

Effects of Libration
(for equal- Δa boosts)

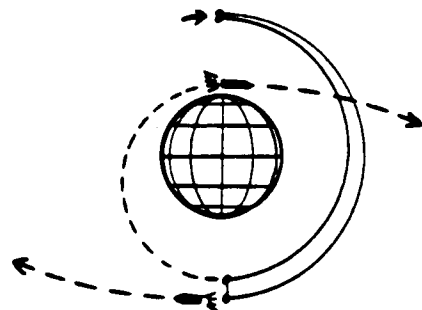

If done right, a tether boost/deboost operation can reduce ΔV -to-escape for both end masses!

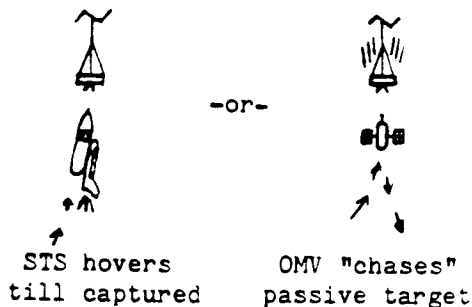
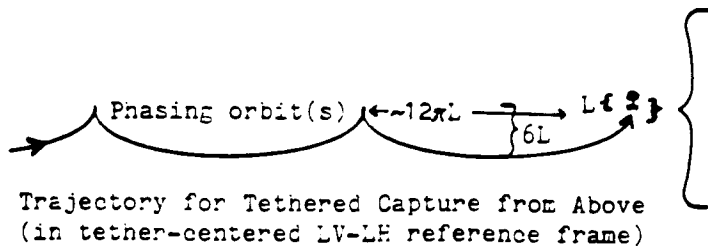

Figure A.21. Orbit Transfer by Tethered Release of Capture
[Ref. 1, p. 21] Cited from p. 2-27.

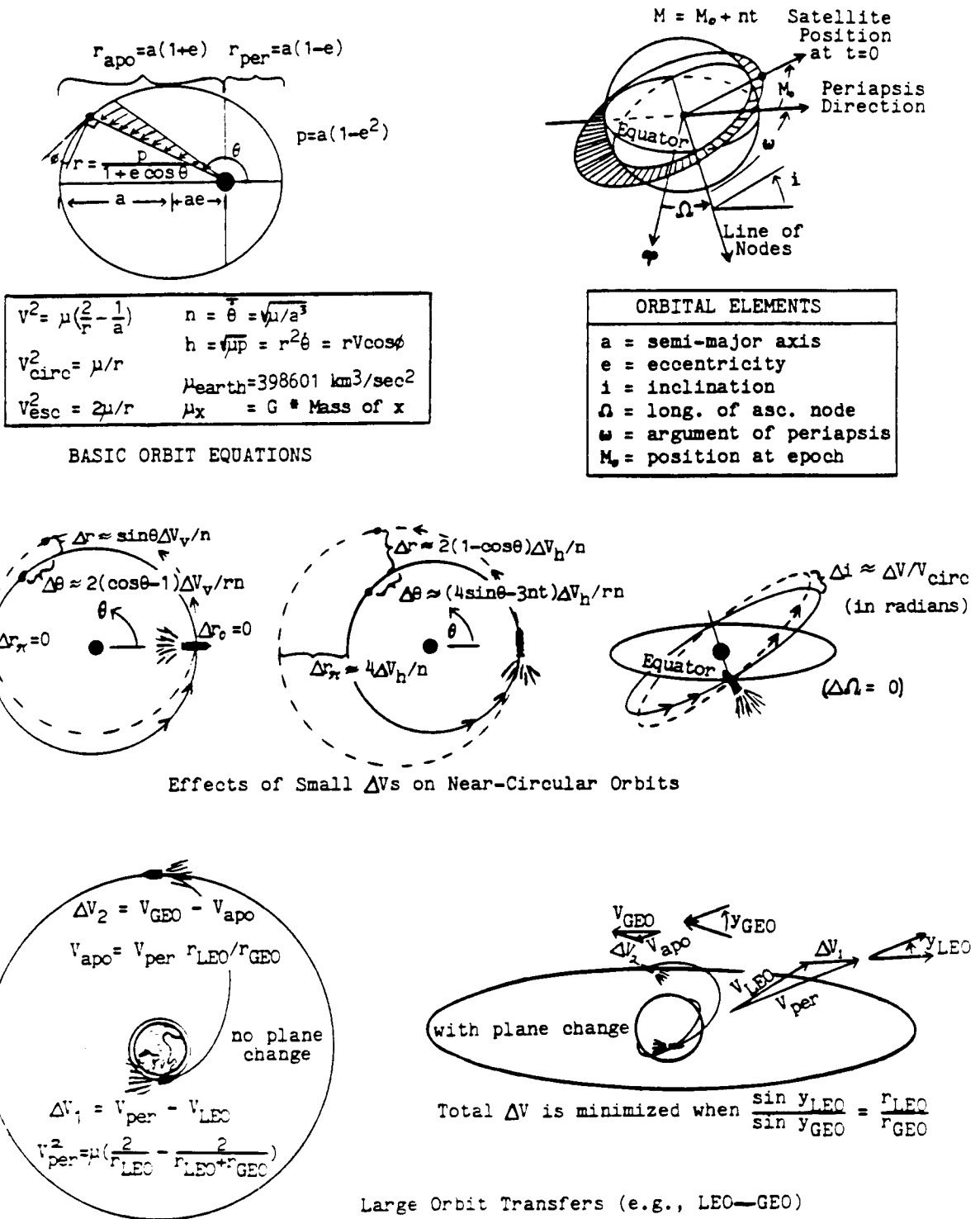

Figure A.22. Orbit and Orbit Transfer Equations [Ref. 1, p. 3] Cited from p. 2-27.

ORIGINAL PAGE IS
OF POOR QUALITY

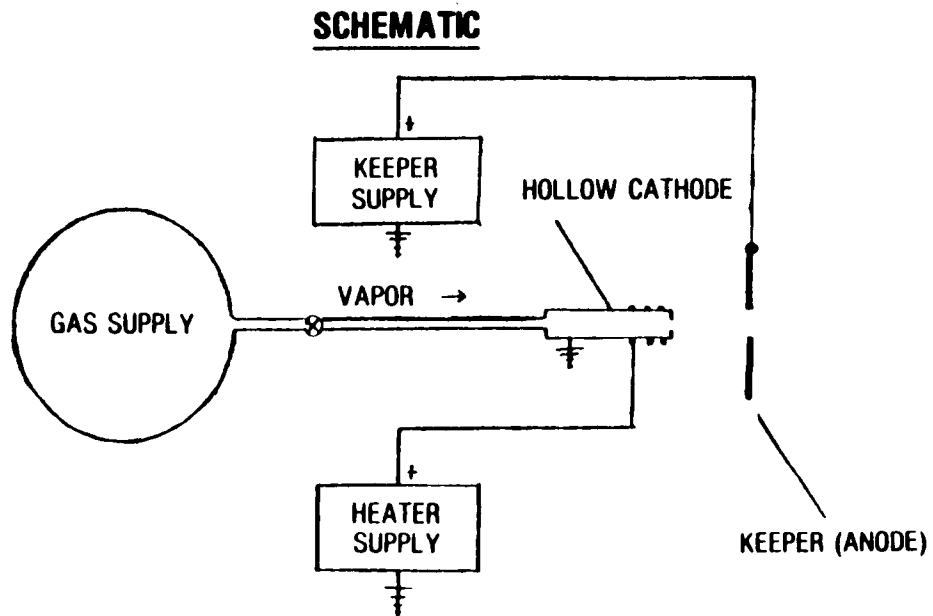
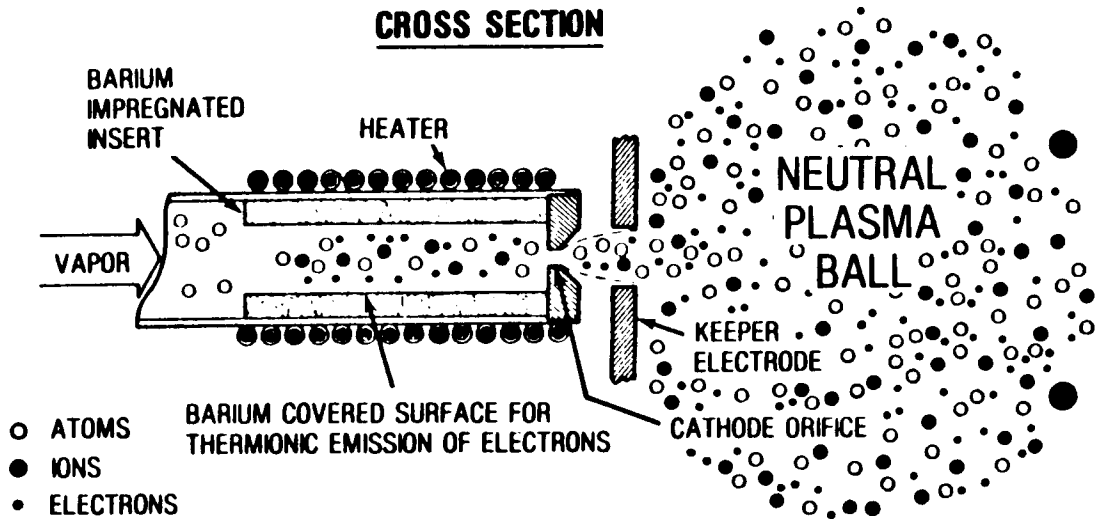

Figure A.23. Diagrams of a Hollow Cathode Plasma Contacter [reference 37] Cited from p. 2-34.

Plasma Motor/Generator Hollow Cathode Assembly

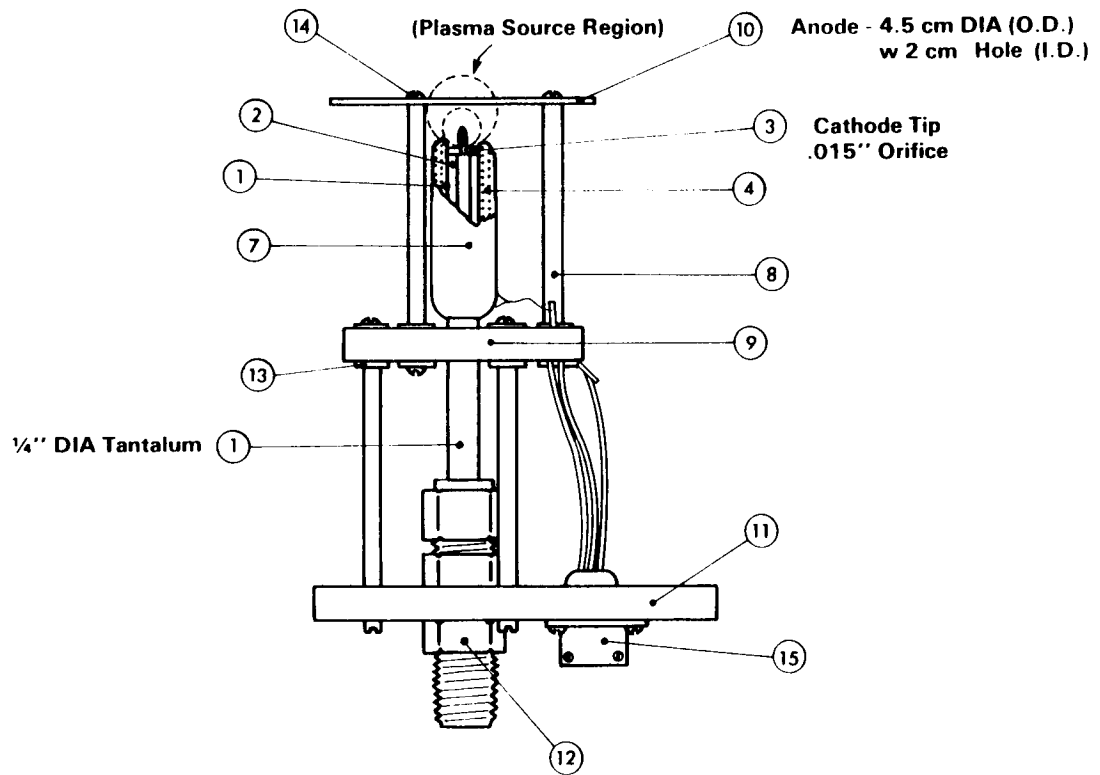

Figure A.24. Diagram of the Plasma Motor-Generator (PMG) Hollow Cathode Assembly [Ref. - Dr. James McCoy (NASA/JSC)] Cited from p. 2-34.

ORIGINAL PAGE IS
OF POOR QUALITY

Hollow Cathode Operation as Plasma Contactor

Plasma "Cloud" Expansion

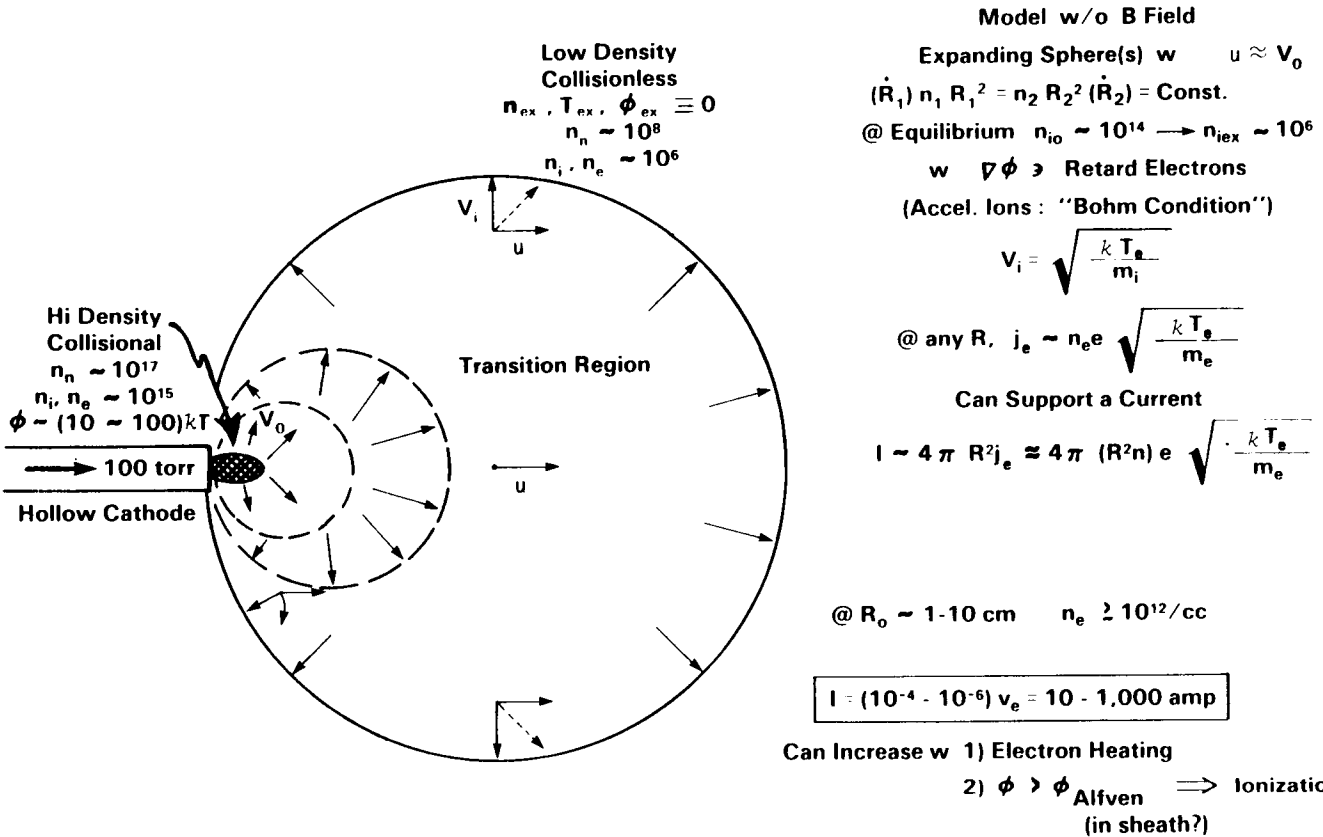

Figure A.25. Plasma Cloud Expansion for PMG Hollow Cathode Plasma Contactor [Ref. - Dr. James McCoy (NASA/JSC); and 9, p. 572] Cited from p. 2-34.

Hollow Cathode Operation as Plasma Contactor

Electron Current Flow to/from Ionosphere

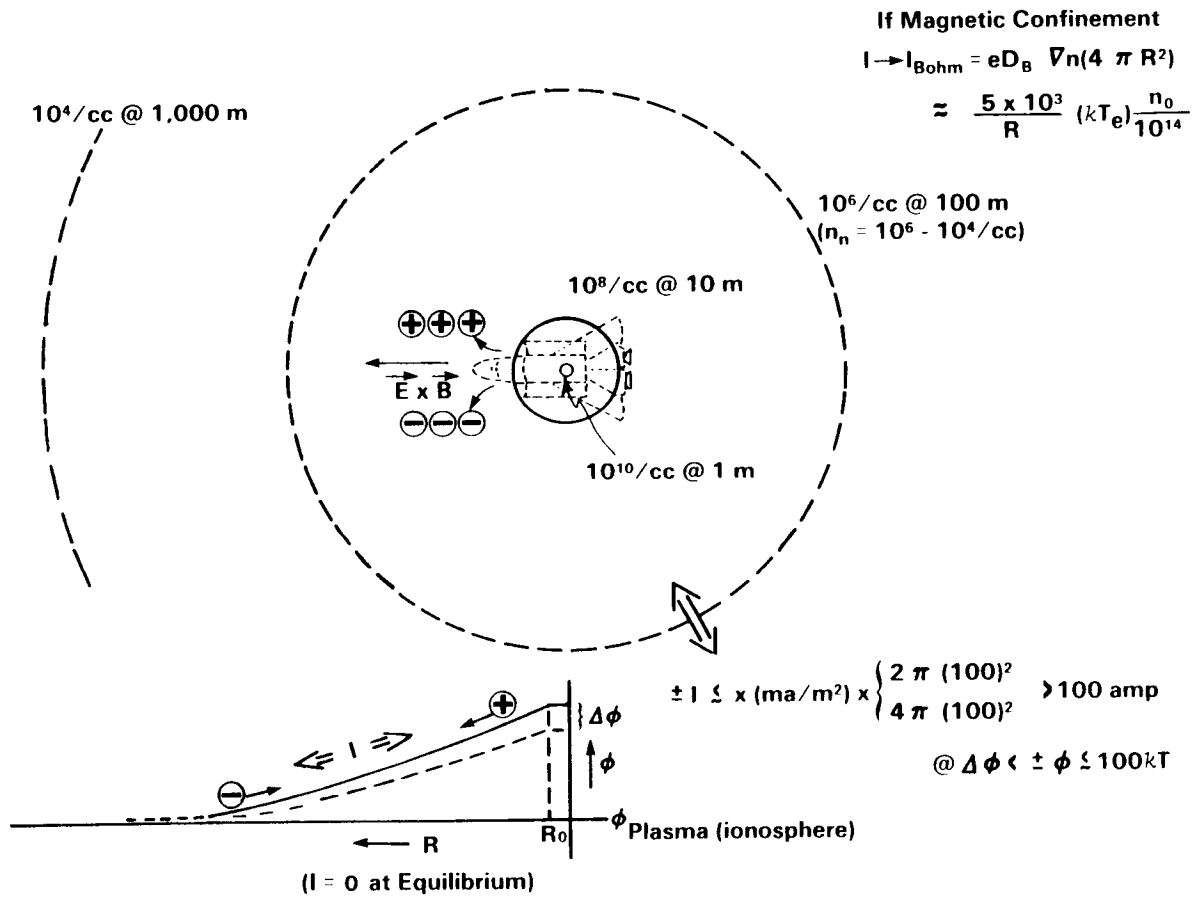
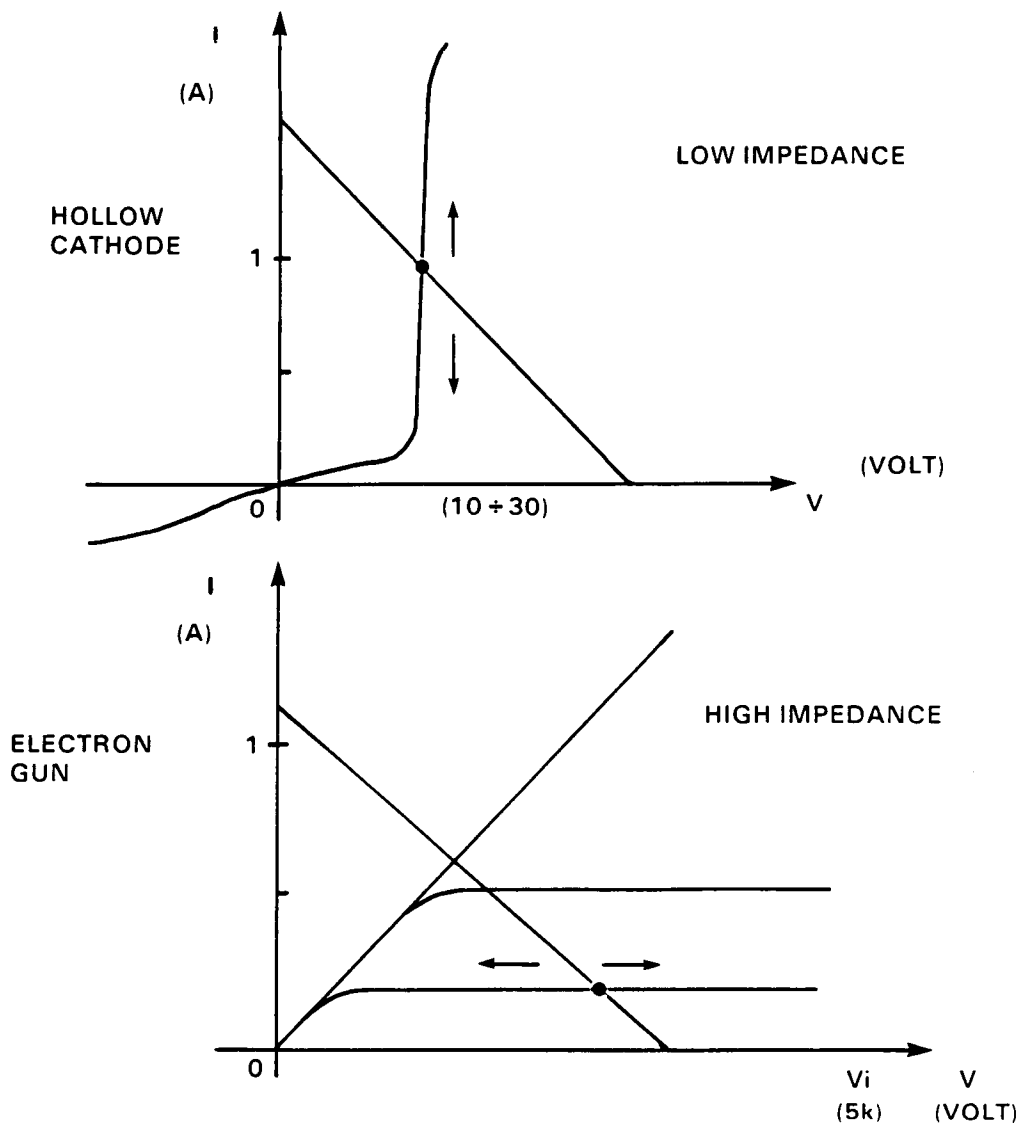

Figure A.26. Electron Current Flow To/From the Ionosphere for PMG Hollow Cathode Plasma Contactor [Ref. - Dr. James McCoy (NASA/JSC); and 9, p. 573] Cited from p. 2-34.



Top, I-V typical characteristics of a Hollow Cathode

Bottom, Electron Gun characteristics. This information shows that electron guns may be operated in a constant current mode independently of voltage whereas the hollow cathode may be operated in a constant voltage mode essentially independent of current. Thus, use of a hollow cathode, or more generally, a plasma generator, provides a ground "strap" tying the spacecraft to the local plasma potential.

Figure A.27. Comparison of the IV Characteristics of a Hollow Cathode and Electron Gun [Ref. 9, p. 388] Cited from p. 2-34.

	<u>Electron Gun</u>	<u>Hollow Cathode</u>
- Current Range:	$I_e \sim 1A$	* $I_{e,i} > 10A, 1A$
- Power Consumption	$\sim 1 kW$	$\sim 10W$
- Life Time:	Similar	Similar
- Automatic Switching	No	Yes
- Main Applications	Basic Science Exp. and Power Dissipation	Low Impedance Coupling Power Generation Thrusting

*Nominal Values

Figure A.28. Table of the Main Comparative Characteristics of an Electron Gun and a Hollow Cathode [Ref. 9, p. 391] Cited from p. 2-34.

PMG - 20 KW REFERENCE SYSTEM

TETHER LENGTH	10 KM	WORKING TENSION	21 N
NOMINAL VOLTAGE	2 KV	WORKING ANGLE	7 DEG
RATED POWER	20 KW	RATED THRUST	2.5 N
PEAK POWER	125 KW	PEAK THRUST	>40. N
CONDUCTOR	#2 AWG ALUMINUM WIRE DIAMETER 6.5 MM @ 20°C RESISTANCE 8.4 OHMS @ 20°C 7.7 OHMS @ 0°C 7.1 OHMS @ -20°C		908 KG
INSULATION	0.5 MM TEFLON (100 VOLTS/MIL)		99 KG
FAR END MASS	10 AMP HOLLOW CATHODE ASS'Y (INCLUDING ELECTRONICS & CONTROL)		10 KG
TETHER CONTROLLER	ELECTRONICS & MISC. HDWR. (POWER DISSIPATION LOSSES @1% = 200W)		83 KG
ARGON SUPPLY & CONTINGENCY RESERVE			<u>100 KG</u>
TOTAL			<u>1,200 KG</u>
TETHER DYNAMICS CONTROL	PASSIVE, 1XB PHASING		
TETHER CURRENT/POWER CONTROL	DC IMPEDANCE MATCHING		
TETHER OUTSIDE DIAMETER	7.5 MM		
TETHER BALLISTIC DRAG AREA	75 SQ. METERS		
DRAG FORCE @ 10 ⁻¹¹ 3 ³ KG/M	.045 N		.36 KW
(300 KM 1976 USSA-400 KM SOLAR MAX)			
I ² R LOSSES @ 20 KW			.77 KW
HOLLOW CATHODE POWER			.50 KW
IONOSPHERIC LOSS @ 10 AMP			<u>.05 KW</u>
TOTAL PRIMARY LOSSES			1.68 KW
EFFICIENCY	ELECTRIC (18.68 KW NET @ 10 AMP/20 KW)	93.4%	
	OVERALL (20.36 MECH. TO 18.68 ELEC. KW)	91.7%	
INCLUDING CONTROLLER/POWER PROCESSER LOSSES @ 1%			<u>.20 KW</u>
TOTAL (NET POWER OUT 18.48 KW)			1.88 KW
FINAL EFFICIENCY	ELECTRIC = 92.4%	OVERALL = 90.8%	

Figure A.29. Calculated Performance of an Example
Electromagnetic Tether System
[Ref. 9, p. 168] Cited from pp. 2-37, 2-40,
Applications EL.01, EL.02.

<u>PMG - 200 KW REFERENCE SYSTEM</u>			
TETHER LENGTH	20 KM (10 UP+10 DN)	WORKING TENSION	42 N
NOMINAL VOLTAGE	4 KV	WORKING ANGLE	17 DEG
RATED POWER	200 KW	RATED THRUST	25 N
PEAK POWER	500 KW	PEAK THRUST	>100 N
CONDUCTOR	#00 AWG ALUMINUM WIRE DIAMETER 9.3 MM @ 20°C RESISTANCE 8.4 OHMS @ 20°C 7.7 OHMS @ 0°C 7.1 OHMS @ -20°C		3640 KG
INSULATION	0.5 MM TEFLON (100 VOLTS/MIL)		278 KG
FAR END MASS	50 AMP HOLLOW CATHODE ASS'Y (INCLUDING ELECTRONICS & CONTROL)		25 KG
TETHER CONTROLLER	ELECTRONICS & MISC. HWWR. (POWER DISSIPATION LOSSES @1% = 2 KW)		94 KG
ARGON SUPPLY & CONTINGENCY RESERVE			<u>163 KG</u>
TOTAL			4,200 KG
TETHER DYNAMICS CONTROL	PASSIVE, 1XB PHASING		
TETHER CURRENT/POWER CONTROL	DC IMPEDANCE MATCHING		
TETHER OUTSIDE DIAMETER	10.3 MM		
TETHER BALLISTIC DRAG AREA	206 SQ METERS		
DRAG FORCE @ 10 ⁻¹¹ KG/M ³	.12 N		.96 KW
(300 KM 1976 USSA-400 KM SOLAR MAX)			
I R LOSSES @ 200 KW			19.25 KW
HOLLOW CATHODE POWER			2.50 KW
IONOSPHERIC LOSS @ 50 AMP			<u>1.25 KW</u>
TOTAL PRIMARY LOSSES			23.96 KW
EFFICIENCY	ELECTRIC (177 KW NET @ 50 AMP/200 KW)	88.5%	
	OVERALL (201 MECH. TO 177 ELEC. KW)	88.1%	
INCLUDING CONTROLLER/POWER PROCESSOR LOSSES @ 1%			<u>2.00 KW</u>
TOTAL (NET POWER OUT 175.0 KW)			25.96 KW
FINAL EFFICIENCY	ELECTRIC = 87.5%	OVERALL = 87.1%	

Figure A.30. Calculated Performance of an Example Electromagnetic Tether System [reference 40, p. 151] Cited from pp. 2-37, 2-40, Applications EL.01, EL.02.

**ORIGINAL PAGE IS
OF POOR QUALITY**

PMG - MEGAWATT REFERENCE SYSTEM

TETHER LENGTH	20 KM (10 UP+10 DN)	WORKING TENSION	190 N
NOMINAL VOLTAGE	4 KV	WORKING ANGLE	10 DEG
RATED POWER	500 KW	RATED THRUST	65 N
PEAK POWER	>2 MW	PEAK THRUST	>400 N
CONDUCTOR	2 CM ALUMINUM WIRE		17,860 KG
	DIAMETER 20.0 MM @ 20°C		
	RESISTANCE 1.68 OHMS @ 20°C		
	1.54 OHMS @ 0°C		
	1.42 OHMS @ -20°C		
INSULATION	0.5 MM TEFLON (100 VOLTS/MIL)		580 KG
FAR END MASS	125 AMP HOLLOW CATHODE ASS'Y (INCLUDING ELECTRONICS & CONTROL)		50 KG
TETHER CONTROLLER	ELECTRONICS & MISC. HWWR. (POWER DISSIPATION LOSSES @1% = 5 KW)		120 KG
ARGON SUPPLY & CONTINGENCY RESERVE			<u>290 KG</u>
TOTAL			<u>19,000 KG</u>
TETHER DYNAMICS CONTROL	PASSIVE, IXB PHASING		
TETHER CURRENT/POWER CONTROL	DC IMPEDANCE MATCHING		
TETHER OUTSIDE DIAMETER	21.0 MM		
TETHER BALLISTIC DRAG AREA	420 SQ METERS		
	-11		
	3		
DRAG FORCE @ 10 KG/M	.25 N		2.0 KW
(300 KM 1976 USSA-400 KM SOLAR MAX)			
2			
I R LOSSES @ 500 KW			<u>24.1 KW</u>
HOLLOW CATHODE POWER			5.0 KW
IONOSPHERIC LOSS @ 125 AMP			<u>7.8 KW</u>
TOTAL PRIMARY LOSSES			36.9 KW
EFFICIENCY	ELECTRIC (463.1 KW NET @ 500 KW)		92.6%
	OVERALL (502 MECH. TO 463 ELEC. KW)		92.3%
INCLUDING CONTROLLER/POWER PROCESSOR LOSSES @ 1%			<u>5.0 KW</u>
TOTAL (NET POWER OUT 458.1 KW)			41.9 KW
FINAL EFFICIENCY	ELECTRIC = 91.6%	OVERALL = 91.3%	

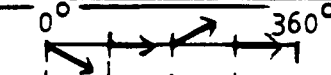

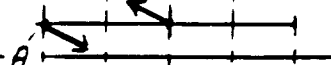
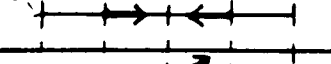
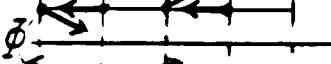

Figure A.31. Calculated Performance of an Example Electromagnetic Tether System [reference 40, p. 152] Cited from pp. 2-37, 2-40, Applications EL.01, EL.02.

RECOMMENDED APPLICATIONS

- I. THRUST - USE WITH SOLAR ARRAYS IN LOW EARTH ORBIT TO OFFSET DRAG
- 100 KG SYSTEM PRODUCING .1 NEWTON THRUST
- 8 KW/N ELECTRIC POWER CONSUMPTION = .8KW
- ELIMINATES DELTA-V FUEL REQUIRED: >1,000 KG/YR
- KEEP 100 KW SOLAR ARRAY @ SPACE STATION ORBIT
- INCREASE TO 200 KG SYSTEM @ 1-2 N THRUST
KEEP SPACE STATION + 100KW ARRAY IN <300 KM ORBIT ALTITUDE
NO ORBIT MAINT. FUEL REQUIRED; CONSUMABLES = < 60 KG/YR (ARGON)
USES 10-15 KW FROM 100 KW AVAILABLE
- II. THRUST - USE FOR ORBITAL MANUEVERING PROPULSION
- 2,000 KG SYSTEM (PLUS 80 KW POWER SUPPLY: SOLAR, NUCLEAR, WHAT-EVER)
- 10 NEWTON THRUST - CONTINUOUS AS LONG AS POWER AVAILABLE
- ALTITUDE CHANGE
- 7 KM/DAY - 200,000 KG (SPACE STATION)
- 30 KM/DAY - 50,000 KG (PLATFORM)
- 150 KM/DAY - 10,000 KG (FREE-FLYER)
- TOTAL IMPULSE: 864,000 N-SEC/DAY (194,000 LB-SEC/DAY)
- 17 M/SEC/DAY - 50,000 KG (PLATFORM)
- 86 M/SEC/DAY - 10,000 KG (FREE-FLYER, OMV, OR "TUG")
- ORBIT PLANE CHANGE: 30 DEGREE IN 6 MONTHS MAY BE POSSIBLE
- "FLY" ENTIRE SPACE STATION DOWN TO 200-250 KM ALTITUDE & MAINTAIN
- GROWTH VERSION: 200 N @ 1.6 MW, 20,000 KG + POWER SUPPLY
- III. POWER STORAGE - 100KW SOLAR ARRAY SYSTEM
+ 2,000 KG REVERSIBLE MOTOR/GENERATOR TETHER SYSTEM
- 60 KW THRUST DURING DAY (POWER STOREAGE AS ORBIT ENERGY)
- 100 KW POWER GENERATION DURING DARK
- TOTAL SYSTEM WEIGHT 40% OF CONVENTIONAL ARRAY WITH BATTERIES
- 10% REDUCTION IN SOLAR ARRAY SIZE
- 60% REDUCTION IN POWER PROCESSING HEAT REJECTION REQUIRED

Figure A.32. Recommended Applications and Calculated Performance of Example Electromagnetic Tether Systems [Ref. 9, p. 175] Cited from pp. 2-37, 2-40, Applications EL.01, EL.02, EL.03, EL.04

ORIGINAL PAGE IS
OF POOR QUALITY

Element	Strategy	Thrust Vector	Effect
Semimajor axis	DC		$\Delta a \approx \cos(i) \frac{kl}{m} \int I dt$
Phase	Sawtooth		$\Delta M \approx \cos(i) \frac{1.5 kl \eta}{ma} \int I t dt$
Eccentricity	$\cos(\theta)$		$\Delta e \approx \cos(i) \frac{kl}{ma} \int I \cos(\theta) dt$
Line of apsides	$\sin(\theta)$		$\Delta \omega \approx \cos(i) \frac{kl}{mae} \int I \sin(\theta) dt$
Inclination	$-\cos(2\phi)$		$\Delta i \approx \frac{-kl}{2ma} \int I \sin(i) \cos^2(\phi) dt$
Ascending node	$-\sin(2\phi)$		$\Delta \Omega \approx \frac{-kl}{2ma} \int I \sin(\phi) \cos(\phi) dt$

θ = POSITION OF VEHICLE WITH
REFERENCE TO ITS PERIGEE

ϕ = POSITION WITH REFERENCE
TO ASCENDING NODE

k = ~4 TONNES PER AMPERE
DAY * $(r_e/r)^{1.5}$

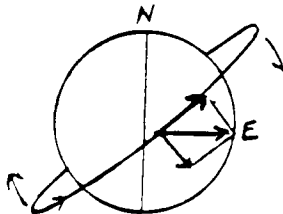

l = TETHER LENGTH

m = TOTAL VEHICLE MASS

η = ORBITAL ANGULAR RATE

Figure A.33. How to Change Orbits Using an Electromagnetic Tether
[Ref. 1, p. 31] Cited from p. 2-41.

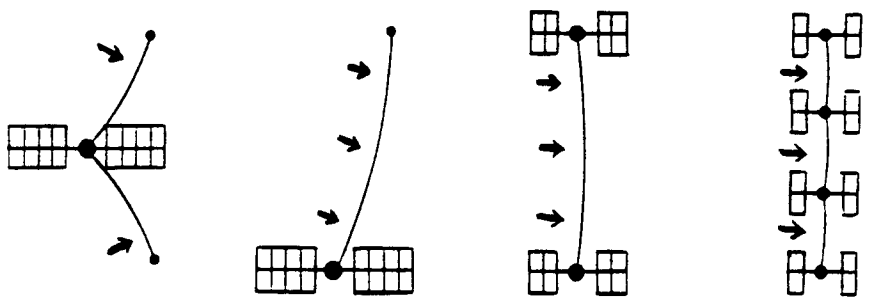
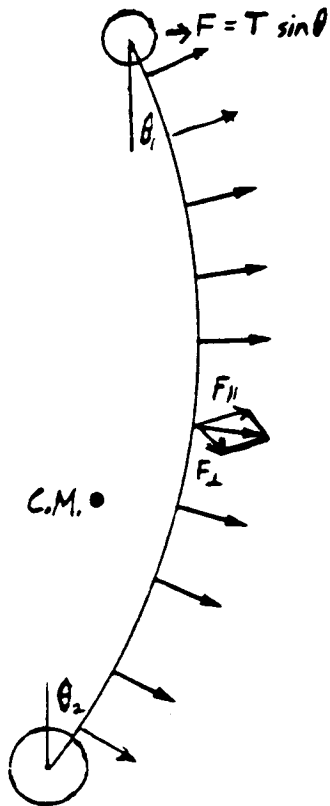

INCREASING STABILITY \longrightarrow
(for fixed total length & mass & I)

FOR CONTROL OF:	MODULATE I AT:
Out-of-plane libration*	1 n or 3 n
In-plane libration*	1.73 n
Tether oscillations	>5 n

* I or mass distribution must be lopsided

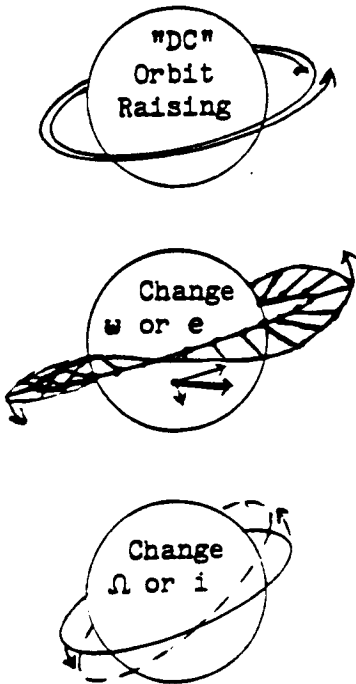

Tether Current:

$I = 1.0$

$I = \sin \phi$

$I = \cos \phi$

$I = \text{Sign of } (.5 + \sin \phi)$

$I = \text{Sign of } (.5 + \cos \phi)$

$I = \sin 2\phi$

$I = \cos 2\phi$

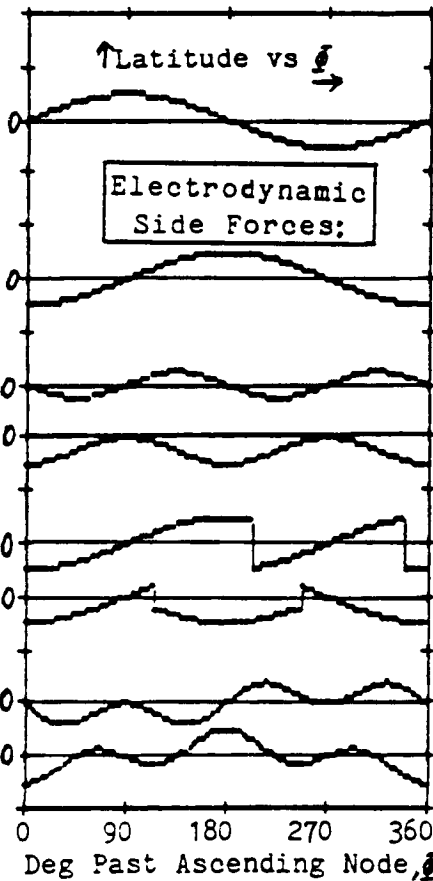

Fourier Analysis of Out-Of-Plane Forces

	1n	2n	3n
Electrodynamic Side Forces:	.50	0	0
$I = \sin \phi$	0	.50*	0
$I = \cos \phi$	0	.50	0
$I = \text{Sign of } (.5 + \sin \phi)$.50	.65	.39
$I = \text{Sign of } (.5 + \cos \phi)$.03	.51	.07
$I = \sin 2\phi$.50	0	.50
$I = \cos 2\phi$.50	0	.50

* drives phi libration

Figure A.34. Electromagnetic Libration Control Issues
[Ref. 1, p. 33] Cited from p. 2-41.

Generic Issues in Various Tether Applications

MAJOR CONSTRAINTS IN MOMENTUM-TRANSFER APPLICATIONS

CONSTRAINT: APPLICATION:	ORBIT BASICS	TETHER DYNAMICS	TETHER PROPERTIES	TETHER OPERATIONS
All types	Apside location	Forces on end masses	μ meteoroid sensitivity	Tether recoil at release
Librating		Tether can go slack		Facility attitude & "g"s variable
Spinning		High loads on payload		Retrieval can be difficult
Winching		High loads on payload		Extremely high power needed
Rendezvous	Orbit planes must match			Short launch & capture windows
Multi-stage	Dif. nodal regression			Waiting time between stages
High Δv	Gravity losses	Control of dynamics	Tether mass & lifetime	Retrieval energy; Facility Δ alt.

MAJOR CONSTRAINTS WITH PERMANENTLY-DEPLOYED TETHERS

CONSTRAINTS: APPLICATION:	ORBIT BASICS	TETHER DYNAMICS	TETHER PROPERTIES	TETHER OPERATIONS
All types	Aero. drag	Libration	Degradation, μ meteoroids & debris impact.	Recoil & orbit changes after tether break
Electrodynamic	Misc changes in orbit	Plasma disturbances	High-voltage insulation	
Aerodynamic	Tether drag & heating			
Beanstalk (Earth)			Tether mass; debris impact	Consequences of failure
Gravity Use: Hanging Spinning		Libr-sensitive		<.1 gee only. Docking awkward

Figure A.35. Generic Issues in Various Tether Applications
[Ref. 1, p. 99] Cited from p. 3-5.

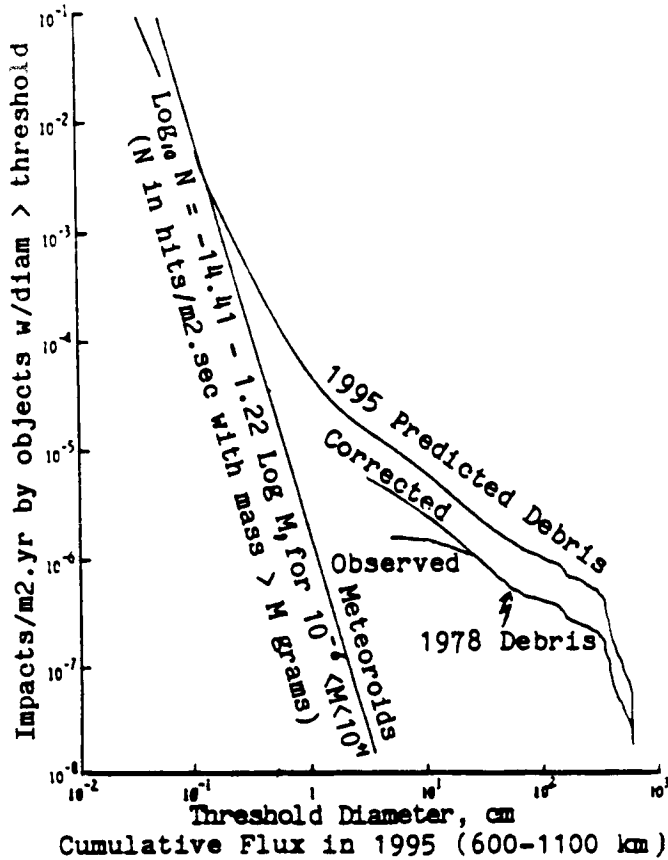

Figure A.36. Micrometeoroids and Debris Damage
 [Ref. 1, p. 11] Cited from p. 3-5.

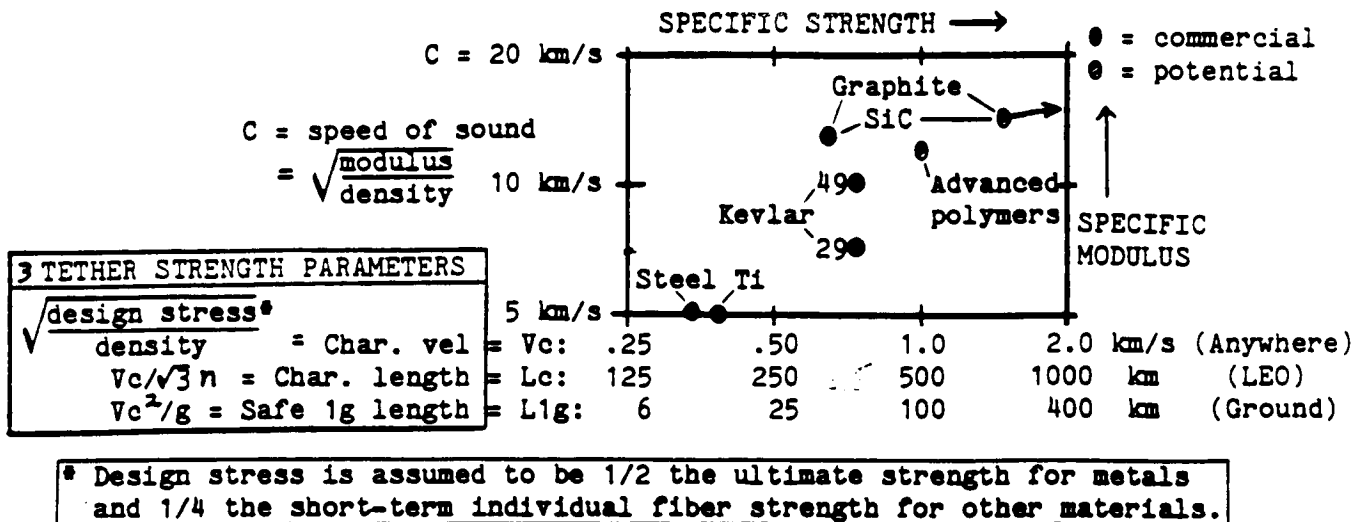
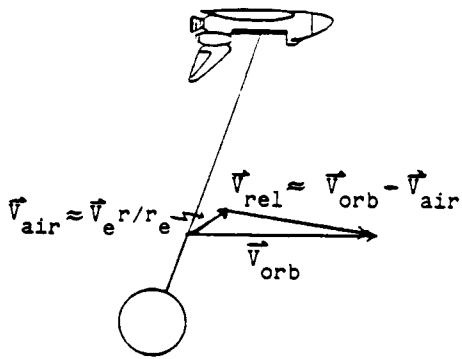

Figure A.37. Specific Strength & Modulus of Several Tether Materials
 [Ref. 1, p. 25] Cited from p. 3-5.

ORIGINAL PAGE IS
OF POOR QUALITY

Aerodynamic Drag



$$F_{drag} = .5 \int \rho C_D V_{rel}^2 \text{ Width } \delta r$$

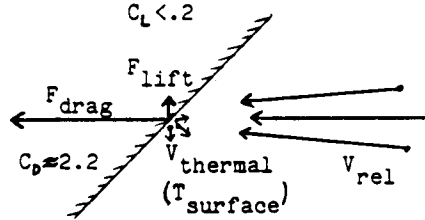
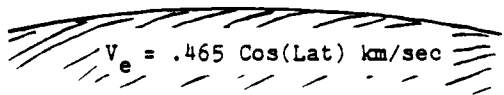

Lift & Drag in Free-Molecular Flow
($\bar{\lambda} \gg D_{tether}$; $\bar{\lambda} = \frac{10^{-7} \text{ kg/m}^2}{\rho}$)

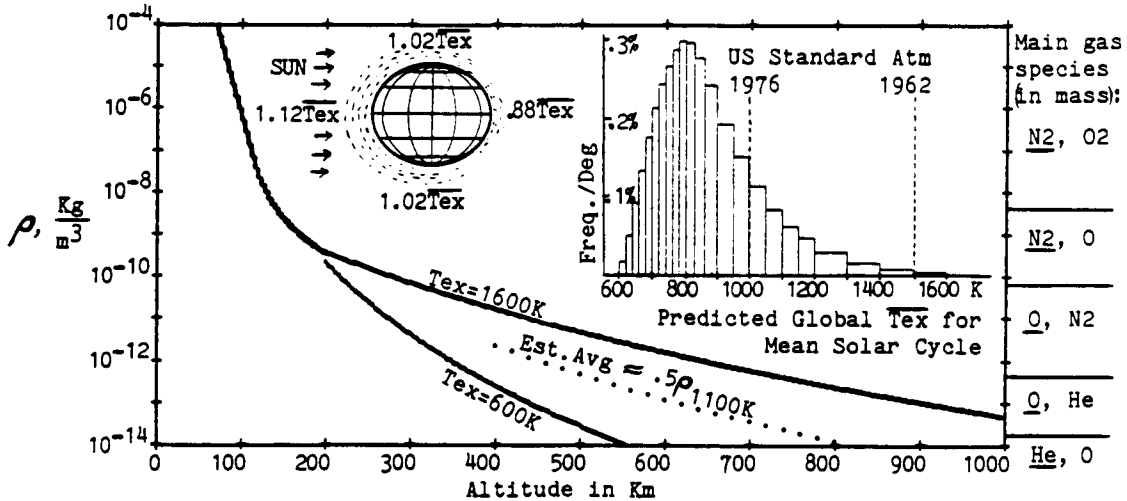

Air Density as Function of Altitude & Exosphere Temperature

70 < Alt < 118:	$\rho \approx 11 \exp(-\text{Alt}/6)$	$-\rho/\dot{\rho} = H = 6 \text{ (km)}$
118 < Alt < 200:	$\rho \approx (\text{Alt}-95)^{-3}/2600$	$H = (\text{Alt}-95)/3$
200 < Alt < 1E+14 &:	$\rho \approx \frac{1.47E-16 \text{ Tex}(3000-\text{Tex})}{(1+2.9(\text{Alt}-200)/\text{Tex})^{10}}$	$H = .1(\text{Alt}-200) + \text{Tex}/29$

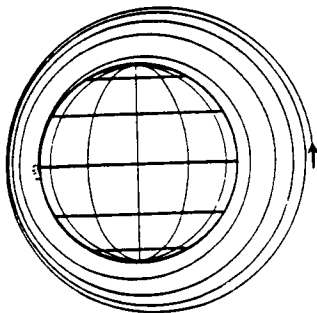

$$\text{Circular Orbit Life} \approx \frac{.15 \text{ m}^2 \text{ yr}}{\text{kg}} \frac{M}{C_D A} \frac{(1 + 2.9(r-6578)/\text{Tex})^{11}}{3000 - \text{Tex}}$$

(-14 < Log ρ < -10)

$$\text{Equal-Life Circ. Alt.} \approx \text{Perigee} + \frac{\text{Apo} - \text{Per}}{2 + .154(\text{Apo}-\text{Per})/H_{\text{Per}}}$$

Figure A.38. Aerodynamic Drag [Ref. 1, p. 97] Cited from p. 3-5.

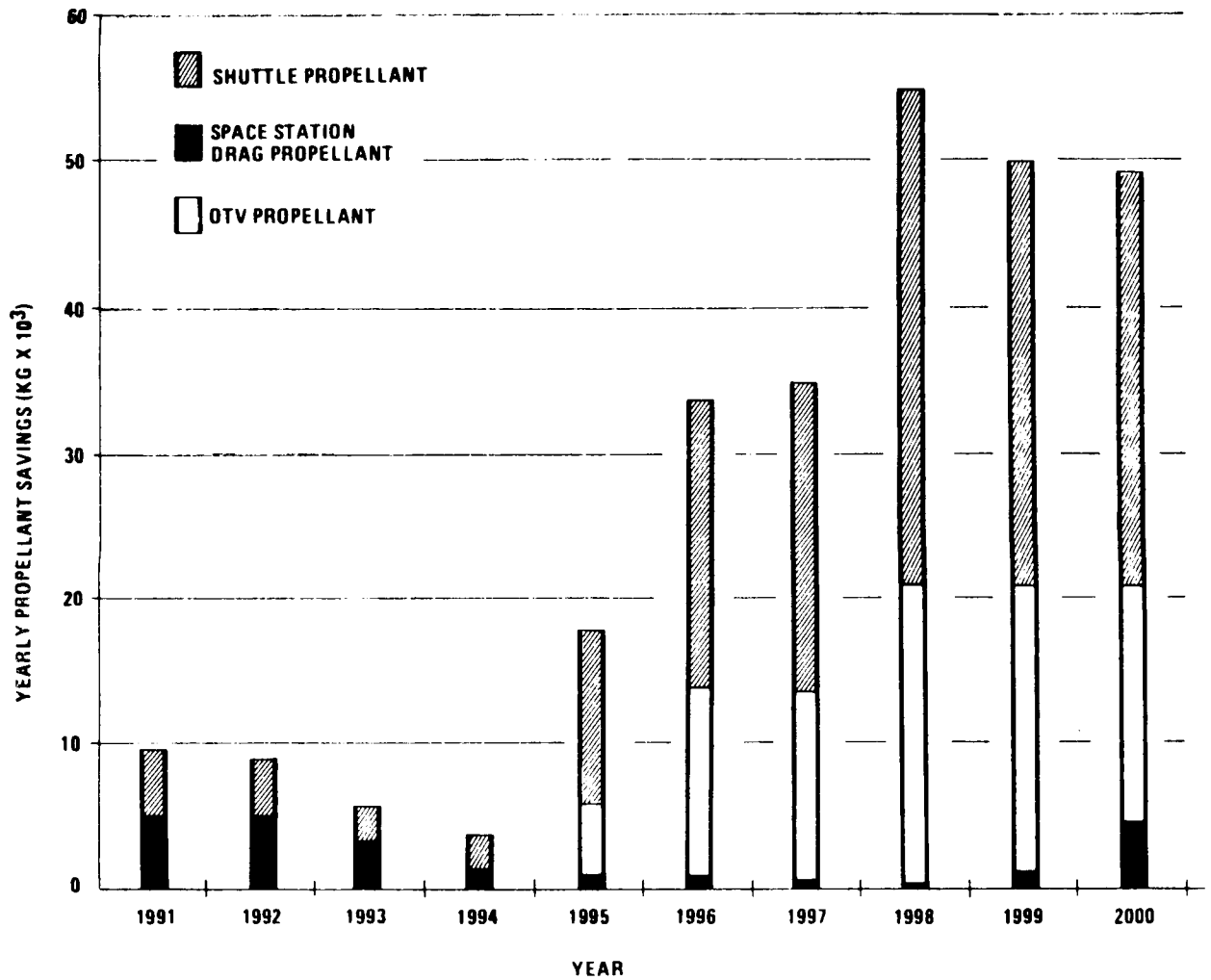

Figure A.39. Tether Benefits in Terms of Annual Propellant Savings
 [Ref. 13, p. 43] Cited from Applications SS.06, SS.07.

SCIENCE APPLICATIONS

- o Aeronomy
 - Neutral Density Characterization
 - Ionospheric Physics
 - Chemistry
 - Fluid Dynamics

- o Basic Scientific Research
 - Magnetic Monopole Detection
 - Michelson-Morley Experiment
 - High Accuracy Measurement of Gravitational Constant
 - Detection of Gravitational Waves
 - Astronomy
 - Planetary Science

- o Electrodynamics
 - Electromagnetic Waves
 - Plasma Physics

- o Geodynamics
 - Geomagnetic Fields
 - Gravity Fields
 - Crustal Investigation

- o Remote Sensing
 - Cartography (Stereoscopic)
 - Vegetative Classification
 - Hydrology

Figure A.40. Science Applications Major Categories
[Ref. 9, 10] Cited from Application SA.02.

SECTION 5
REFERENCES AND SELECTED BIBLIOGRAPHY

**References and
Selected
Bibliography**

5.1. REFERENCES

PRECEDING PAGE BLANK NOT FILMED

5.1 REFERENCES

The following reference numbers match those used throughout the Tethers in Space Handbook.

1. J.A. Carroll "Guidebook for Analysis of Tether Applications," Contract RH4-394049, Martin Marietta Corporation, March 1985. Available from Mail Code PS01, MSFC, NASA.
2. J. Sisson, "Development Status of First Tethered Satellite System," NASA/Marshall Space Flight Center, Alabama, January 1986.
3. M. Nolan, R. Hudson, J. Sisson, D. Crouch, M. Vignoli, "Shuttle Tethered Satellite Program," June 1984.
4. E. Vallerani, F. Bevilacqua, F. Giani, "Tethered Satellite System Present Program and Future Applications," AAS 85-124.
5. Applications of Tethers in Space, Vol. 1, Workshop Proceedings, Williamsburg, Virginia, June 15-17, 1983, NASA CP-2364, March 1985.
6. Applications of Tethers in Space, Vol. 2, Workshop Proceedings, Williamsburg, Virginia, June 15-17, 1983, NASA CP-2365, March 1985.
7. J. Pearson, "Anchored Lunar Satellites for Cislunar Transportation and Communication," Journal of Astronautical Sciences, Vol. 27, No. 1., pp. 39-62, Jan-Mar 1979.
8. "Study of Orbiting Constellations in Space," Contract RH4-394019, Martin Marietta, Smithsonian Astrophysical Observatory, December 1984.
9. Applications of Tethers in Space, Workshop Proceedings, Volume 1, Venice, Italy, NASA CP2422, March 1986.
10. Applications of Tethers in Space, Workshop Proceedings, Volume 2, Venice, Italy, NASA CP2422, March 1986.
11. Applications of Tethers in Space, Workshop Proceedings, Executive Summary, Venice, Italy, NASA CP2422, March 1986.
12. D.T. Greenwood, Principles of Dynamics, Prentice Hall, Inc., Englewood Cliffs, New Jersey, 1965.
13. G. von Tiesenhausen, ed., "The Roles of Tethers on Space Station," NASA TM-86519, Marshall Space Flight Center, October 1985.
14. M.D. Grossi, "Spaceborne Long Vertical Wire as a Self-Powered ULF/ELF Radiator," IEEE Journal of Oceanic Engineering, Vol. OE-9, No. 3, pp. 211-213, July 1984.

15. P.A. Penzo "ELF/ULF Radio Wave Generation Using Tethers," JPL Tethers in Space Studies Report, 1986.
16. G. von Tiesenhausen, ed., Tether Applications Concept Sheets, June 28, 1984.
17. F. Bevilacqua, P. Merlina, and A. Anselmi, "The Science and Applications Tethered Platform (SATP) Project," Aeritalia Space Systems Group, Torino, Italy, Tether Applications in Space Workshop, Venice, Italy, October 15-17, 1985.
18. J. Laue and F. Manarini, "The Tethered Retrievable Platform Concept and Utilization," IAF-82-13, 33rd IAF Congress, Paris, France, September-October 1982.
19. S. Vetrella and A. Moccia, "A Tethered Satellite System as a New Remote Sensing Platform," University of Naples, Italy, Undated.
20. "Tether Released Recovery," Final Report, NASA Contract NAS8-35096.
21. "SATP Definition Study," Mid-Term Report, Aeritalia, TA-RP-AI-002, March 21, 1986.
22. M.D. Grossi, "Theoretical Investigation of the Generation and Injection of Electromagnetic Waves in Space Plasma by Means of a Long Orbiting Tether," Final Report, Contract NAS8-33520, February 1981.
23. "Selected Tether Applications in Space, Phase III," NASA Contract NAS8-36616.
24. "Selected Tether Applications in Space, Phase III," NASA Contract NAS8-36617.
25. G. Colombo, D.A. Arnold, M. Dobrowolny, M.D. Grossi, "Investigation of Electrodynamical Stabilization and Control of Long Orbiting Tethers," Contract NAS-33691, Interim Report, Smithsonian Astrophysical Observatory, March 1981.
26. M. Martinez-Sanchez and S.A. Gavit, "Four Classes of Transportation Applications Using Space Tethers," Space Systems Laboratory, Massachusetts Institute of Technology in Contract with Martin Marietta, March 1984.
27. M. Martinez-Sanchez, "The Use of Large Tethers for Payload Orbital Transfer," Massachusetts Institute of Technology, 1983.
28. G. Colombo, "The Use of Tethers for Payload Orbital Transfer," NASA Contract NAS8-33691, Vol. II, March 1982.
29. D. Stuart, "Tethered Rendezvous and Docking," Draper Labs, NASA Contract NAS8-36602.

30. V. Chobotov, "Gravity-Gradient Excitation of a Rotating Cable-Counterweight Space Station in Orbit," Journal of Applied Mechanics, Vol. 30, pp. 547-554.
31. A.C. Clarke, "The Space Elevator: 'Thought Experiment', or Key to the Universe?," Adv. Earth Oriented Appl. Space Techn., Vol. 1, pp. 39-48, 1981.
32. NASA Tech Brief, 1985.
33. H.L. Mayer, "Swarms: Optimum Aggregations of Spacecraft," Aerospace Corporation, ATR-80(7734)-1, February 29, 1980.
34. "Tethered Orbital Refueling Study," Contract No. NAS9-17059, Martin Marietta.
35. L.G. Napolitano and F. Bevilacqua, "Tethered Constellations, Their Utilization as Microgravity Platforms and Relevant Features," IAF-84-439.
36. S. Bergamaschi, P. Merlina, "The Tethered Platform: A Tool for Space Science and Application," AIAA-86-0400, AIAA 24th Aerospace Sciences Meeting, Reno, Nevada, January 6-9, 1986.
37. P.A. Penzo, "Tether for Mars Space Operation," JPL, 1984 Conference Paper, University of Colorado, Boulder, Colorado, July 10-14, 1984.
38. P.A. Penzo and H.L. Mayer, "Tethers and Asteroids for Artificial Gravity Assist in the Solar System," JPL, AIAA Paper 84-2056, August 1984.
39. P.A. Penzo, JPL Tethers in Space Studies Report, 1986.
40. Proceedings of Tether Applications in Space Program Review, McLean, VA, General Research Corporation, July 1985.
41. V.B. Braginski and K.S. Thorne, "Skyhook Gravitational Wave Detector," Moscow State University, Moscow, USSR, and Caltech, 1985.
42. B. Bertotti, R. Catenacci, M. Dobrowolny, "Resonant Detection of Gravitational Waves by Means of Long Tethers in Space," Technical Note (Progress Report), Smithsonian Astrophysical Observatory, Cambridge, Massachusetts, March 1977.
43. R.V. Stachnik, D.Y. Gezari, "SAMSI: An Orbiting Spatial Interferometer for Micro-Arcsecond Astronomical Observations," Proc. Colloquium "Kilometric Optical Arrays in Space," Cargese (Corsica), October 23-25, 1984 (ESA SP-226, April 1985).

44. G.J. Corso, "A Proposal to Use an Upper Atmosphere Satellite Tethered to the Space Shuttle for the Collection of Micro-Meteoritic Material," Journal of the British Interplanetary Society, Vol. 36, pp. 403-408, 1983.
45. James E. McCoy, "PMG Reference System Designs for Power & Propulsion," abstract.
46. Unknown, "Utilization of the External Tanks of the STS," draft of results from workshop held at the University of California, San Diego, August 23-27, 1982.
47. "Preliminary Feasibility Study of the External Tank (ET) Deorbit by a Tether System," Marten Marietta Memo 83-SES-665, May 24, 1983.
48. M.C. Contella, "Tethered Deorbit of the External Tank," Johnson Space Center, April 24, 1984.
49. J.A. Carroll, "Tethers and External Tanks: Enhancing the Capabilities of the Space Transportation System," Research and Consulting Services, La Jolla, California, December 20, 1982.
50. L. Bright, "Saturn Ring-Rendezvous Mission Utilizing a Tethered Sub-Satellite," JPL, Memorandum 312/84.8-938, May 7, 1984.
51. "Tether Assisted Penetrators for Comet/Asteroid Sample Return," by Paul A. Penzo (JPL); paper submitted for 1986 AIAA/AAS Astrodynamics Conference.
52. H. Alfven, "Spacecraft Propulsion: New Methods," Science, Vol. 176, pp. 167-168, April 14, 1972.
53. K. Kroll, Presentation Package for the NASA Tether Working Group Meeting at Marshall Space Flight Center, February 1986.

5.2. SELECTED BIBIOLOGRAPHY

5.2.1 General

1. I. Bekey, "Advanced Tether Applications," Briefing to the Administrator, August 10, 1984.
2. I. Bekey, "Tethers Open New Space Options," AIAA Astronautics and Aeronautics, April 1983.
3. I. Bekey, "Applications of Space Tethers," IAF Paper 84-436.
4. V.V. Beletskii and M. Guivertz, "The Motion of an Oscillating Rod Subjected to a Gravitational Field," Kosmitcheskie Issledovania 5, No. 6, 1967.
5. V.V. Beletskii, "The Motion of Celestial Bodies," Nauka, Moscow, 1971.
6. J.A. Carroll "Guidebook for Analysis of Tether Applications," Contract RH4-394049, Martin Marietta Corporation, March 1985. Available from Mail Code PS01, MSFC, NASA, March 1985.
7. J.A. Carroll "Some Tether-Related Research Topics," prepared under JPL Contract No. LC 778278 for NASA Tether Applications in Space Task Force, November 1984.
8. J.A. Carroll, "Tether Applications in Space, An Overview of Possible Roles for Tethers in Space Transportation and Large Space Structures," California Space Institute, 1983.
9. J.B. Eades and H. Wolf, "Tethered Body Problems and Relative Motion Orbit Determination," NAS-5-21453, Analytical Mechanics Association, Inc., August 1982.
10. T.R. Kane, Journal of Astronautical Sciences, 32, 351, 1984.
11. D.J. Kessler and B.G. Cour-Palais, Journal Geophysical Research 83, 2637, 1978.
12. D.D. Lang and R.K. Nolting, "Operations with Tethered Space Vehicles," Gemini Summary Conference, NASA SP-138, 1967.
13. J. Laue, "U.S./Italian Discussion on Tether Related Activities at NASA Headquarters," NASA/MSFC, November 18, 1982.
14. L.G. Lemke, Proposal to NASA, 1984.
15. L. Niven and S. Barnes, The Decent of Anansi, Pinnacle Books, 1982 (Novel).
16. W. Nobles, "Selected Tether Applications in Space," NASA Contract NAS8-35499, July 31, 1984.

PRECEDING PAGE BLANK NOT FILMED

17. W. Nobles, "Selected Tether Applications in Space," Martin Marietta, Final Report, NASA Contract NAS8-35499, February 1985.
18. C. Sheffield, The Web Between the Worlds, Ace Science Fiction, 1978 (Novel).
19. T.E. Sterne, "An Introduction to Celestial Mechanics," Interscience Tracts on Physics and Astronomy, Ch. 5.2, 1960.
20. K.E. Tsiolkovsky, "Grezi o zemi i nebe (Speculations Between Earth and Sky)," Moscow, Izd-vo AN SSR, first published in 1895, p. 35, 1959.
21. G. von Tiesenhausen, "Tethers in Space--Birth and Growth of a New Avenue to Space Utilization," NASA TM-82571, February 1984.
22. G. von Tiesenhausen, ed., Tether Applications Concept Sheets, June 28, 1984.
23. Applications of Tethers in Space, Workshop Proceedings, Executive Summary, Williamsburg, Virginia, June 15-17, 1983, NASA CP-2366, March 1985.
24. Applications of Tethers in Space, Vol. 1, Workshop Proceedings, Williamsburg, Virginia, NASA CP-2364, June 15-17, 1983.
25. Applications of Tethers in Space, Vol. 2, Workshop Proceedings, Williamsburg, Virginia, NASA CP-2365, June 15-17, 1983.
26. Proceedings of Tether Applications in Space Program Review, McLean, VA, General Research Corporation, July 17-18, 1985.
27. "Proposed 1984-1987 Program Plan for Tether Applications in Space," prepared by NASA Tether Applications in Space Task Group, September 1983.
28. "Advanced Military Spaceflight Capability Technology Identification Study," Final Report, F33615-81-C-3033, April 1983.
29. "Aerospace Highlights 1984," Aerospace America, pp. 27, 35, December 1984.
30. "Selected Tether Applications in Space: An Analysis of Five Selected Concepts," Final Report/Presentation, Martin Marietta, NAS8-35499, July 31, 1984.
31. The Way Things Work, An Illustrated Encyclopedia of Technology, Simon and Schuster, 1967.
32. "Technical Support Package: Methods for Estimating Payload/Vehicle Design Loads," NASA Tech Briefs, Vol. 7, No. 4, JPL, Summer 1983.

33. Applications of Tethers in Space, Workshop Proceedings, Volume 1, Venice, Italy, NASA CP2422, March 1986.
34. Applications of Tethers in Space, Workshop Proceedings, Volume 2, Venice, Italy, NASA CP2422, March 1986.
35. Applications of Tethers in Space, Workshop Proceedings, Executive Summary, Venice, Italy, NASA CP2422, March 1986.
36. "Selected Tether Applications in Space, Phase III," NASA Contract NAS8-36616.
37. "Selected Tether Applications in Space, Phase III," NASA Contract NAS8-36617.
38. Military Space Systems Technology Model, Final Report, SD-TR-83-01, Air Force Space Technology Center, February 1983.
39. Military Space Systems Technology Plan, Volume IIIA: Technology Trends and Forecasts, Air Force Space Technology Center, October 1984.
40. Movies for Gemini Missions XI and XII, available from Public Affairs Office, AP2, NASA, HSC, Houston, Texas .

5.2.2 Tethered Satellite System

1. P.M. Bainum and V.K. Kumar, "Optimal Control of the Shuttle-Tethered System," ACTA ASTRONAUTICA, Vol. 7, pp. 1333-1348, presented as IAF #79-190 at the 30th IAF Congress, Munich, Germany, September 1979.
2. W. Baker, J.A. Dunkin, Z.J. Galaboff, K.D. Johnson, R.R. Kissel, M.H. Rheinfurth and M.P.L. Siebel, "Tethered Subsatellite Study," NASA TM X-73314, Marshall Space Flight Center, March 1976.
3. A.K. Banerjee and T.R. Kane, "Tethered Satellite Retrieval with Thruster Augmented Control," AIAA/AAS Astrodynamics Conference, San Diego, CA, AIAA 82-1-21, 1982.
4. P.M. Banks, P.R. Williamson and K.L. Oyama, "Shuttle Orbiter Tethered Subsatellite for Exploring and Tapping Space Plasmas," Astronautics and Aeronautics, February 1981.
5. S. Bergamaschi, "A Theoretical and Experimental Investigation on TSS Dynamics," Proposal in response to NASA-CNR/PSN AO.n.OSSA 1-84, July 1984.
6. F. Buckens, "On the Motion Stability of Tethered Satellites Configuration," Proceedings of the 12th International Symposium on Space Technology and Science, H. Nagasu, ed., AGNE Publishing, Inc., pp. 351-358, Tokyo, 1977.
7. G. Colombo, "Study of Tethered Satellite Active Attitude Control," NASA Contract NAS8-33691, Interim Report, Smithsonian Astrophysical Observatory, October 1982.
8. G. Colombo, D. Arnold, E. Gaposchkin, M. Grossi, P. Kalaghan and L. Kirschner, "Tethered Satellite System for Gravity Gradiometry at Low Orbital Height," presented at the Earth Dynamics Summer Workshop, Boulder, Colorado, July 1977.
9. G. Colombo, E. Gaposchkin, M. Grossi, G. Weiffenbach, "Gravity-Gradient Measurements Down to 100 km Height by Means of Long Tethered Satellites," presented at 27th IAF Congress, Anaheim, California, October 1977.
10. G. Colombo, E. M. Gaposchkin, M. D. Grossi and G. C. Weiffenbach, "Shuttle-Borne Skyhook: A New Tool for Low-Orbital-Altitude Research," Smithsonian Astrophysical Observatory, Reports in Geoastronomy, No. 1, 1974.
11. G. Colombo, E.M. Gaposchkin, M.D. Grossi and G.C. Weiffenbach, "The Skyhook: A Shuttle-Borne Tool for Low Orbital Altitude Research," MECCANICA, March 1975.

12. G. Colombo, E.M. Gaposchkin, M.D. Grossi, and G.C. Weiffenbach, "Shuttle-Borne Long-Tethered Satellites, A Tool for Low Cost Space Science and Applications," presented at AAS/AIAA Conference, Nassau, Bahamas, July 1975.
13. G. Colombo, E.M. Gaposchkin, M.D. Grossi, and G.C. Weiffenbach, "Long Tethered Satellites for the Shuttle Orbiter," presented at the International Conference on Technology of Scientific Space Experiments, Paris, France, May 1975.
14. G. Colombo, E.M. Gaposchkin, M.D. Grossi, D. Lautman, and O. Orringer, "Dumbbell Gravity-Gradient Sensor: A New Application of Long Tethers," Smithsonian Astrophysical Observatory Reports in Geoastronomy, No. 2, 1976.
15. G. Colombo, et al., "Satellite Connected by Means of a Long Tether to a Powered Spacecraft," US Patent 4,097,010, June 27, 1978.
16. G. Colombo, S. Bergamaschi, and F. Bevilacqua, "The Italian Participation to the Tethered Satellite System," IAF #81-33, 32nd IAF Congress, September 1981.
17. D.S. Crouch, "Shuttle Tethered Satellite System Program Overview," Applications of Tethers in Space Workshop, Williamsburg, Virginia, June 15, 1983.
18. C.M. Diarra, "The Effects of Tether Mass on the Stability and the Controllability of the Shuttle-Tethered Subsatellite System," IAF #82-06, 33rd IAF Congress, Paris, France, September 1982.
19. G. Gullahorn, "Investigation and Measurement of Dynamic Noise in Tethered Satellite Systems," Proposal in response to NASA-CNR/PSN AO.n.OSSA 1-84, July 1984.
20. G.E. Gullahorn, F. Fuligni, and M.D. Grossi, "Gravity Gradiometry from the Tethered Satellite System," IEEE Transportation Geoscience Remote Sensing, Volume GE 23, pp. 531-540, 1985.
21. J. Isaacs, H. Bradner, G. Backus, and A. Vine, "Satellite Elongation into a True 'Skyhook'; a letter to Science," Vol. 151, pp. 682-683, February 11, 1966.
22. P.M. Kalaghan, et al., "Study of the Dynamics of a Tethered Satellite System (Skyhook)," Final Report, Contract NAS8-32199, Smithsonian Astrophysical Observatory, Cambridge, Massachusetts, March 1978.
23. T.R. Kane, "A New Method for the Retrieval of the Shuttle-Based Tethered Satellite," Journal of the Astronautical Sciences, Vol. 32, No. 3, July-Sept. 1984.

24. L.R. Kirschner, "The Skyhook Program: A Software Package for a Tethered Satellite System, Including Electrodynamic Interactions," NASA Technical Report, Contract NAS8-33691, May 1980.
25. J. Laue, "Tethered Satellite System-Project Overview," Briefing given NASA/MSFC/PF17, January 19, 1983.
26. G. Manarini and F. Mariani, "The Tethered Satellite System Technical Aspects and Prospective Science Missions," Riena, Atti 22 Convegno Intele Sullo Spazio, Rome, Italy, 1982.
27. F. Mariani, "Science by Tethered Satellite," Dipartimento di Fisica, Universita di Roma "La Sapienza", Piazzale Aldo Moro, 2-00185, Roma, Italy .
28. D.J. McComas, H.E. Spence, R.R. Karl, H.G. Horak, and T.D. Wilkerson, "Bistatic LIDAR Experiment Proposed for the Shuttle/Tethered Satellite System Missions," Review of Scientific Instruments, Vol. 56, No. 5, pp. 670-673, May 1985.
29. A.K. Misra and V.J. Modi, "Deployment and Retrieval of Shuttle Supported Tethered Satellites," University of British Columbia, Vancouver, BC, Canada, 1980.
30. A.K. Misra and V.J. Modi, "A General Dynamical Model for the Space Shuttle Based Tethered Subsatellite System," Advances in the Astronautical Sciences, 40, pp. 537-557, 1979.
31. A.K. Misra and V.J. Modi, "Deployment and Retrieval of a Subsatellite Connected by a Tether to the Space Shuttle," Paper AIAA-80-1693 presented at the AIAA/AAS Astrodynamics Conf., Danvers, Massachusetts.
32. V.J. Modi and A.K. Misra, "Deployment Dynamics and Control of Tethered Satellite Systems," AIAA/AAS #78-1398, AIAA/AAS Astrodynamics Conference, Palo Alto, CA, August 1978.
33. V.J. Modi, G. Chang-fu, A.K. Misra, and D.J. Xu, "On the Control of the Space Shuttle Based Tether System," ACTA ASTRONAUTICA, Vol. 9, No. 6-7, 1982.
34. V.J. Modi, G. Chang-fu, and A.K. Misra, "Effects of Damping on the Control Dynamics of the Space Shuttle Based Tether System," AAS/AIAA Astrodynamics Conference, Lake Tahoe, AAS-81-143 .
35. H. Moravec, "A Non-Synchronous Orbital Skyhook," Journal of the Astronautical Sciences, Vol. 25, No. 4, pp. 307-322, 1977.
36. M. Nolan, R. Hudson, J. Sisson, D. Crouch, M. Vignoli, "Shuttle Tethered Satellite Program," June 1984.

37. C.C. Rupp and J.H. Laue, "Shuttle/Tethered Satellite System," Journal of the Astronautical Sciences, Volume 26, No. 1, pp. 1-17, January 1978.
38. C.C. Rupp and L.L. Gresham, "A Preliminary Study of the Attitude Control for The Shuttle Tether Satellite System," IEEE Journal, 1979.
39. C.C. Rupp, "A Tether Tension Control Law for Tether Satellites Deployed Along Local Vertical," NASA TM X-64963, Marshall Space Flight Center, September 1, 1975.
40. J. Sisson, "Development Status of First Tethered Satellite System," NASA/Marshall Space Flight Center, Alabama, January 1986.
41. W.C. Snoddy, "Scientific and Technical Applications of a Tethered Satellite System," AIAA Aerospace Sciences Meeting, New Orleans, Louisiana, January 15-17, 1979.
42. T.M. Spencer, "Atmospheric Perturbation and Control of a Shuttle/Tether Satellite," Automatic Control in Space, Proceedings of the 8th Symposium, Oxford, England, pp. 101-108, July 2-6, 1978.
43. Unknown, "Shuttle/Tethered Satellite System Definition Study," Final Study Report, NAS8-32854, Martin Marietta Aerospace, April 1979.
44. Unknown, "Shuttle/Tethered Satellite System Conceptual Design Study," NASA TM X-73365, Marshall Space Flight Center, December 1976.
45. Unknown, "The Tethered Satellite System," Final Report from the Facility Requirements Definition Team, sponsored by MSFC under NASA Contract NAS8-33383 to the Center for Atmospheric and Space Sciences, Utah State University, May 1980.
46. E. Vallerani, F. Bevilacqua, F. Giani, "Tethered Satellite System Present Program and Future Applications," AAS 85-124 .
47. S. Vetrella and A. Moccia, "A Tethered Satellite System as a New Remote Sensing Platform," University of Naples, Italy, Undated.
48. S.T. Wu, ed., "University of Alabama at Huntsville/NASA Workshop on The Uses of a Tethered Satellite System," Summary Papers, Huntsville, Alabama, May 1978.
49. D.M. Xu, A.K. Misra, and V.J. Modi, "Three Dimensional Control of the Shuttle Supported Tether Satellite Systems During Deployment and Retrieval," Proceedings of the 3rd VPISU/AIAA Symposium on Dynamics and Control of Large Flexible Spacecraft, Blacksburg, Virginia, 1981.

50. "Shuttle Tethered Satellite System Design Study," NASA TM X-73365, MSFC, 1976.
51. "Shuttle/Tethered Satellite System Definition Study--Final Study Report," NAS8-32853, Ball Aerospace Systems Division, February 1979.
52. "Tethered Satellite System, Advanced Concepts, STS," August 1981.
53. "Tethered Satellite System-Orbital Dynamics Model 1B," Contract No. NAS8-36000, Martin Marietta, February 1985.
54. "The Tethered Satellite System," Final Report from the Facility Requirements Definition Team; sponsored by MSFC under NASA Contract NAS8-33383 to Center for Atmospheric and Space Sciences, Utah State University, May 1980.

5.2.3 Science Applications

1. S. Bergamaschi, P. Merlina, "The Tethered Platform: A Tool for Space Science and Application," AIAA-86-0400, AIAA 24th Aerospace Sciences Meeting, Reno, Nevada, January 6-9, 1986.
2. B. Bertotti, R. Catenacci, M. Dobrowolny, "Resonant Detection of Gravitational Waves by Means of Long Tethers in Space," Technical Note (Progress Report), Smithsonian Astrophysical Observatory, Cambridge, Massachusetts, March 1977.
3. F. Bevilacqua, P. Merlina, and A. Anselmi, "The Science and Applications Tethered Platform (SATP) Project," Aeritalia Space Systems Group, Torino, Italy, Tether Applications in Space Workshop, Venice, Italy, October 15-17, 1985.
4. G.J. Corso, "A Proposal to Use an Upper Atmosphere Satellite Tethered to the Space Shuttle for the Collection of Micro-Meteoritic Material," Journal of the British Interplanetary Society, Vol. 36, pp. 403-408, 1983.
5. R.B. Leighton, "A 10-Meter Telescope for Millimeter and Submillimeter Astronomy," Final Report for NSF Grant AST 73-04908, Caltech, May 1978.
6. F. Mariani, "Science by Tethered Satellite," Dipartimento di Fisica, Universita di Roma "La Sapienza", Piazzale Aldo Moro, 2-00185, Roma, Italy .
7. P.A. Penzo, "Tether Assisted Penetrators for Comet/Asteroid Sample Return," JPL, Preliminary Abstract, submitted for 1986 AIAA/AAS Astrodynamics Conference, January 24, 1986.
8. R.V. Stachnik, D.Y. Gezari, "SAMSI: An Orbiting Spatial Interferometer for Micro-Arcsecond Astronomical Observations," Proc. Colloquium "Kilometric Optical Arrays in Space," Cargese (Corsica), October 23-25, 1984 (ESA SP-226, April 1985).
9. W.J. Webster, Jr., "Application of Tethered Satellites to Some Problems of Terrestrial Physics," Goddard Space Flight Center, 1985.
10. "Large Deployable Reflector Science and Technology Workshop - Volume III: Systems and Technology Assessment," NASA CP-2275, June 1982.
11. "Foil Mirrors Proposed for Space," Military Space, p. 2, November 12, 1984.
12. "SATP Users Requirements Report," Final Report, Aeritalia, TA-RP-AI-001, March 21, 1986.

13. "SATP Definition Study," Mid-Term Report, Aeritalia, TA-RP-AI-002, March 21, 1986.
14. "Scaled SATP - Demonstrative Experiments Definition Study," Final Report, Aeritalia, TA-RP-AI-003, 2 Volumes, March 21, 1986.

5.2.4 Electrodynamics

1. H. Alfven, "Spacecraft Propulsion: New Methods," Science, Vol. 176, pp. 167-168, April 14, 1972.
2. J. Anderson, D. Arnold, G. Colombo, M. Grossi, and L. Kirshner, "Orbiting Tether's Electrodynamical Interactions," final report on NAS5-25077, Smithsonian Astrophysical Observatory, April 1979.
3. D.A. Arnold and M. Dobrowolny, "Transmission Line Model of the Interactions of a Long Metal Wire with the Ionosphere," submitted to Radio Science, 1979.
4. D.A. Arnold and M.D. Grossi, "Natural Damping in the Electrodynamic Tether," Smithsonian Astrophysical Observatory, Cambridge, Massachusetts, January 24, 1983.
5. D.A. Arnold, "General Equations of Motion," Appendix A of "Investigation of Electrodynamical Stabilization and Control of Long Orbiting Tethers," Interim Report, Smithsonian Astrophysical Observatory, March 1981.
6. P.M. Banks, P.R. Williamson and K.L. Oyama, "Shuttle Orbiter Tethered Subsatellite for Exploring and Tapping Space Plasmas," Astronautics and Aeronautics, February 1981.
7. B. Bertotti, R. Catenacci, M. Dobrowolny "Resonant Detection of Gravitational Waves by Means of Long Tethers in Space," Technical Note (Progress Report), Smithsonian Astrophysical Observatory, Cambridge, Massachusetts, March 1977.
8. V.B. Braginski and K.S. Thorne, "Skyhook Gravitational Wave Detector," Moscow State University, Moscow, USSR, and Caltech, 1985.
9. C. Chu and R. Gross, "Alfven Waves and Induction Drag on Long Cylindrical Satellites," AIAA Journal, Vol. 4, p. 2209, 1966.
10. G. Colombo, D.A. Arnold, M. Dobrowolny, M.D. Grossi, "Investigation of Electrodynamical Stabilization and Control of Long Orbiting Tethers," Contract NAS-33691, Interim Report, Smithsonian Astrophysical Observatory, March 1981.
11. M. Dobrowolny, "Wave and Particle Phenomena Induced by an Electrodynamic Tether," Smithsonian Astrophysical Observatory Special Report #388, November 1979.
12. M. Dobrowolny, G. Colombo, M.D. Grossi, "Electrodynamics of Long Conducting Tethers in the Near-Earth Environment," Smithsonian Astrophysical Observatory, Reports in Geoastronomy, No. 3, October 1976.

13. S.D. Drell, H.M. Foley and M.A. Ruderman, "Drag and Propulsion of Large Satellites in the Ionosphere: An Alfvén Propulsion Engine in Space," Journal of Geophysics Res., Vol. 70, No. 13, pp. 3131-3145, July 1965.
14. P.M. Finnegan, "A Preliminary Look at Using a Tethered Wire to Produce Power on a Space Station," NASA LeRC, May 10, 1983.
15. T.B. Garber, "A Preliminary Investigation of the Motion of a Long, Flexible Wire in Orbit," Rand Report RM-2705-ARPA, March 23, 1961.
16. M.D. Grossi, "Spaceborne Long Vertical Wire as a Self-Powered ULF/ELF Radiator," IEEE Journal of Oceanic Engineering, Vol. OE-9, No. 3, pp. 211-213, July 1984.
17. M.D. Grossi, "Theoretical Investigation of the Generation and Injection of Electromagnetic Waves in Space Plasma by Means of a Long Orbiting Tether," Final Report, Contract NAS8-33520, February 1981.
18. M.D. Grossi, "On the Feasibility of Electric Power Generation and Electromagnetic Wave Injection by Electrodynamic Tethers," Tech. Note TP 83-003, Smithsonian Astrophysical Observatory, January 1983.
19. M.D. Grossi, "A ULF Dipole Antenna on a Spaceborne Platform of the PPEPL Class," Report on NASA Contract NAS8-28203, Smithsonian Astrophysical Observatory, May 1973.
20. M.D. Grossi, "Engineering Study of the Electrodynamic Tether as A Spaceborne Generator of Electric Power," NASA Contract NAS8-35497, Smithsonian Astrophysical Observatory, Cambridge, Massachusetts, April 1984.
21. R. Guidici, "Electrodynamic Tether for Power on Propulsion Design Considerations," NASA MSFC-PD, March 20, 1984.
22. R.W.P. King, "The Thin Wire Antenna Embedded in a Magneto-ionic Plasma," Harvard University, 1980.
23. J.E. McCoy, "Electrodynamic Tether Applications - Massive Tether Dynamics Study," General Status Review, NASA JSC-SN 3, May 3, 1984.
24. J.E. McCoy, "Plasma Motor/Generator - Proof of Function Experiment," NASA JSC-SN3, July 1, 1984.
25. J.E. McCoy, "Plasma Motor/Generator - Electrodynamic Tether Applications in Space," NASA JSC-SN 3, June 13, 1984.
26. R.D. Moore, "The Geomagnetic Thruster--A High Performance 'Alfvén Wave' Propulsion System Utilizing Plasma Contacts," AIAA Paper No. 66-257 .

27. J. Pearson, "The Orbital Tower, A Spacecraft Launcher Using the Earth's Rotational Energy," ACTA ASTRONAUTICA, Vol. 2, pp. 785-799, Pergamon, 1975.
28. P.A. Penzo "ELF/ULF Radio Wave Generation Using Tethers," JPL Tethers in Space Studies Report, 1986.
29. Wei-Yuan Tang, "Comparison of Three Kinds of Possible Power Generators as Space Shuttle Power Extension Package," Smithsonian Astrophysical Observatory, Cambridge, Massachusetts, December 31, 1981.
30. W.B. Thompson, "Electrodynamics of a Conducting Tether," Final Report to Martin Marietta Aerospace Corporation, Research Contract RH3-393855, California Space Institute and Department of Physics, University of California, San Diego, December 1983.
31. P.R. Williamson and P.M. Banks, "The Tethered Balloon Current Generator: A Space Shuttle Tethered Subsatellite for Plasma Studies and Power Generation," Final Report, NOAA Contract No. 03-5-022-60, January 1976.
32. P.R. Williamson, et al., "Measurements of Vehicle Potential Using a Mother-Daughter Tethered Rocket," Utah State University, NASA Grant NSG-6027, 1982.
33. P.R. Williamson, P.M. Banks, and K. Oyama, "The Electrodynamic Tether," Utah State University, Logan, Utah, NASA Contract NAS5-23837, May 1978.
34. ULF/ELF Antenna, NASA Contract NAG-551.
35. Unknown, "Report of the Plasma Physics and Environmental Perturbation Laboratory Working Groups," Program Development Contract NASA TM X-64856, March 1974.

5.2.5 Transportation

1. H. Alfven, "Spacecraft Propulsion: New Methods," Science, Vol. 176, pp. 167-168, April 14, 1972.
2. D.A. Arnold, "Orbital Pumping," NASA Contract NAS8-35036, Smithsonian Astrophysical Observatory, August 24, 1984.
3. D.J. Bentz, "Tethered Momentum Launching Systems," NASA LeRC.
4. J.A. Carroll and A.H. Cutler, "Potential Role of Tethers in Space Transportation," AIAA-84-1448, presented at AIAA/SAE/ASME 20th Joint Propulsion Conference, Cincinnati, Ohio, June 1984.
5. J.A. Carroll, "Tethers and External Tanks: Enhancing the Capabilities of the Space Transportation System," Research and Consulting Services, La Jolla, California, December 20, 1982.
6. J.A. Carroll, "Disposable-Tether Payload Deploying System for the STS," Final Report on NASA SBIR Contract NAS8-35843, Energy Science Labs, Inc., June 1984.
7. J.A. Carroll, "Tether Mediated Rendezvous," report to Martin Marietta on Task 3 of Contract No. RH3-393855, California Space Institute, March 1984.
8. J.A. Carroll, "Tether Applications in Space, An Overview of Possible Roles for Tethers in Space Transportation and Large Space Structures," California Space Institute, 1983.
9. J.A. Carroll, "Tether Applications in Space Transportation," IAF Paper 84-438, 35th IAF Congress, Lausanne, Switzerland. Published in ACTA ASTRONAUTICA, 1984.
10. G. Colombo, "Orbital Transfer and Release of Tethered Payloads," report on NASA Contract NAS8-33691, Smithsonian Astrophysical Observatory, March 1983.
11. G. Colombo, "A Straightforward Use of the Shuttle ET," presented at the Workshop on the Utilization of the External Tanks of the STS, California Space Institute, 1982.
12. G. Colombo, "The Use of Tethers for Payload Orbital Transfer," NASA Contract NAS8-33691, Vol. II, March 1982.
13. G. Colombo, "Study of Certain Launching Techniques Using Long Orbiting Tethers," NASA-CR-164060, Smithsonian Astrophysical Observatory, March 1981.
14. G. Colombo, H.L. Mayer, et al., "Use of Tethers for Payload Orbital Transfer," Smithsonian Astrophysical Observatory, NAS8-33691, March 1982.

15. M.C. Contella, "Tethered Deorbit of the External Tank," Johnson Space Center, April 24, 1984.
16. M.W. Hunter, "Near-Earth Transportation Options and High Payoff Choices," AIAA International Annual Meeting, Baltimore, Maryland, May 1982.
17. M.W. Hunter, "Advanced Space Transportation Options," Lockheed, August 1982.
18. I.O. MacConochie, et al., "Capture - Ejector Satellite," NASA-TM 85686, Langley Research Center, October 1983.
19. M. Martinez-Sanchez and S.A. Gavit, "Four Classes of Transportation Applications Using Space Tethers - Preliminary Concept Assessments," progress report to Martin Marietta, Massachusetts Institute of Technology Space Systems Laboratory, March 1984.
20. M. Martinez-Sanchez, "The Use of Large Tethers for Payload Orbital Transfer," Massachusetts Institute of Technology, 1983.
21. P. Merlina, "Double-Tethered Satellite System," Aeritalia-Settore Spazio, November 23, 1982.
22. J. Pearson, "Using the Orbital Tower to Launch Earth-Escape Payloads Daily," AIAA Paper 76-123, 27th IAF Congress, 1976.
23. J. Pearson, "Anchored Lunar Satellites for Cislunar Transportation and Communication," Journal of Astronautical Sciences, Vol. 27, No. 1., pp. 39-62, Jan-Mar 1979.
24. J. Pearson, "Asteroid Retrieval by Rotary Rocket," AIAA Paper 80-0116, presented at the AIAA 18th Aerospace Sciences Meeting, Pasadena, CA, January 1980.
25. G. Ryan, "Tether Applications for the Inertial Upper Stage, IUS Futures," The Boeing Company, January 1985.
26. D.G. Stuart and M. Martinez-Sanchez, "Shuttle Tether Use for Payload Deployment to Circular Orbits," Massachusetts Institute of Technology, August 10, 1984.
27. D.G. Stuart, "Tethered Rendezvous and Docking," Draper Labs, NASA Contract NAS8-36602 .
28. J. Tschirgi, "Tether Deployed SSUS-A," NASA Contract NAS8-32842, McDonnell Douglas, April 1984.
29. "A Study of Transportation Applications of Space Tethers," Final Report, Massachusetts Institute of Technology Space Systems Laboratory, Contract No. RH4-394007 from Martin Marietta, February 1985.

30. "Preliminary Feasibility Study of External Tank (ET) Deorbit by a Tether System," Martin Marietta Memo 83-SES-665, May 24, 1983.
31. "The Process of Space Station Development Using External Tanks," California Space Institute of the University of California, Scripps Institution of Oceanography, La Jolla, Report to Director of the Space Station Review Project, Office of Technology Assessment, March 11, 1983.
32. Unknown, "Utilization of the External Tanks of the STS," draft of results from workshop held at the University of California, San Diego, August 23-27, 1982.

5.2.6 Controlled Gravity

1. J. Anderson, G. Colombo, L. Friedman, and E. Lau, "An Arrow to the Sun," presented at International Symposium on Experimental Gravitation, Pavia, Italy, September 1976.
2. V. Chobotov, "Gravity-Gradient Excitation of a Rotating Cable-Counterweight Space Station in Orbit," Journal of Applied Mechanics, Vol. 30, pp. 547-554.
3. D. Fester, K. Hamlyn, et al., "Tethered Orbital Refueling Study," NASA Contract NAS9-17059, January 1985.
4. K. Hamlyn, et al., "Tethered Orbital Refueling Study," NASA Contract NAS9-17059, Martin Marietta, October 1985, In Progress.
5. L.G. Napolitano and F. Bevilacqua, "Tethered Constellations, Their Utilization as Microgravity Platforms and Relevant Features," IAF-84-439.
6. P.A. Penzo, "Tether Induced Gravity for Space Station - Preliminary Assessment," JPL, March 12, 1982.
7. "Tethered Orbital Refueling Study," Contract No. NAS9-17059, Martin Marietta, In Progress.

5.2.7 Constellations

1. G. Colombo, "A New Tethered Dual Platform Space Station Concept," NASA Contract G82678-3286, Smithsonian Astrophysical Observatory, October 1983.
2. G. Colombo, "A Preliminary Study of the Orbiting Platform-Tether System Space Operation Center," Massachusetts Institute of Technology Dept. of Aeronautics and Astronautics, 1980.
3. E. Lorenzini, "Analytical Investigation of Dynamics of Tethered Constellations in Earth Orbit," NASA Contract NAS8-35497, Final Report, Smithsonian Astrophysical Observatory, December 1985.
4. H.L. Mayer, "Swarms: Optimum Aggregations of Spacecraft," Aerospace Corporation ATR-80(7734)-1, February 29, 1980.
5. L.G. Napolitano and F. Bevilacqua, "Tethered Constellations, Their Utilization as Microgravity Platforms and Relevant Features," IAF-84-439.
6. P.D. Nicaise and C.C. Rupp, "Dynamics of Orbiter Separation From a Tethered Platform/Station/Orbiter Constellation," Advanced Systems Office, Marshall Space Flight Center, 1985.
7. "Study of Orbiting Constellations in Space," Contract RH4-394019, Martin Marietta, Smithsonian Astrophysical Observatory, December 1984.

5.2.8 Technology and Test

5.2.8.1 General

1. J. Anderson, G. Colombo, L. Friedman, and E. Lau, "An Arrow to the Sun," presented at International Symposium on Experimental Gravitation, Pavia, Italy, September 1976.
2. Y. Artsutanov, "V Kosmos na Electrovoze," Komsomolskaya Pravda, July 31, 1960.
3. P. Birch, "Orbital Ring Systems and Jacob's Ladders-1", Journal of the British Interplanetary Society, Vol. 35, No. 11, pp. 474-497, November 1982.
4. P. Birch, "Orbital Ring Systems and Jacob's Ladders-2", Journal of the British Interplanetary Society, Vol. 36, No. 3, pp. 115-128, December 1982.
5. A.C. Clarke, "The Space Elevator: 'Thought Experiment' or Key to the Universe?," Address to the 30th IAF Congress, Munich, September 20, 1979.
6. A.C. Clarke, "The Space Elevator: 'Thought Experiment,' or Key to the Universe?," Adv. Earth Oriented Appl. Space Techn., Vol. 1, pp. 39-48, 1981.
7. A.C. Clarke, The Fountains of Paradise, Ballantine Books. Includes a postscript discussing the history of the "space elevator" concept, 1978 (novel).
8. Iwata, "Space Escalator, a Quasi-Permanent Engine in Space," presented at the 30th IAF Congress, Munich, September 1979.
9. J. Laue and F. Manarini, "The Tethered Retrievable Platform Concept and Utilization," IAF-82-13, 33rd IAF Congress, Paris, France September-October 1982.
10. C. Lundquist and G. Colombo, "Advanced Technologies in Space and Opportunities for Gravity Experiments," presented at the International School of Relativistic Astrophysics, Trapani, Italy, Fall 1977.
11. W.K. Muench, "Automatic Fabrication of Large Space Structures--The Next Step," Journal of Spacecraft and Rockets, pp. 286-288, May-June 1980.
12. B.S. Perrine, "A Method for Soft Tethered Station Keeping," NASA TMX-53643, MSFC, July 31, 1967.
13. Polyakov, "A Space 'Necklace' about the Earth (Kosmicheskoye ozherel'ye zemli)," Technika Molodezhi, No. 4, pp. 41-43, (NASA TM-75174), 1977.

14. R.E. Simberg, "The Geosynchronous Tidal Web: A Method for Constructing an Ultra-Large Space Structure," Space Manufacturing 4, Proceedings of the 5th Princeton/AIAA Conference, published by AIAA, May 18-21, 1981.
15. D. Stuart, "Tethered Rendezvous and Docking," Draper Labs, NASA Contract NAS8-36602 .
16. H.H. Walters and J.W. Stokes, "Construction In Space--Toward a Fresh Definition of the Man/Machine Relation," Astronautics and Aeronautics, p. 43, May 1979.
17. P.R. Williamson, et al., "Measurements of Vehicle Potential Using a Mother-Daughter Tethered Rocket," Utah State University, NASA Grant NSG-6027, 1982.
18. "Tether Applications in Space: Project Plan for Technology and Test of Tether Applications," NASA HQ, Code MT, Revision A, June 1984.

5.2.8.2 Dynamics and Control

1. E. Allias and S. Bergamaschi, "Dynamics of Tethered Satellites -- Two Alternative Concepts for Retrieval," MECCANICA, pp. 103-111, June 1979.
2. W.W. Anderson, "On Lateral Cable Oscillations of Cable-Connected Space Station," NASA TN 5107, NASA LaRC.
3. D. Arnold, "General Equations of Motion," Appendix A of "Investigation of Electrodynamical Stabilization and Control of Long Orbiting Tethers," Interim Report, Smithsonian Astrophysical Observatory, March 1981.
4. P.M. Bainum, R.E. Harkness, and W. Stuver, "Attitude Stability and Damping of a Tethered Orbiting Interferometer Satellite System," Journal of Astronautical Sciences, Vol. XIX, No. 5, pp. 364-389, March-April 1972.
5. V.V. Beletskii and E.M. Levin, "Mechanics of an Orbital Cable System," translated from Kosmicheskie Issledovaniya, Vol. 18, #5, pp. 678-688, September-October 1980.
6. V.V. Beletskii, "Resonance Phenomena at Rotations of Artificial and Natural Celestial Bodies," COSPAR-IAU-IUTAM Satellite Dynamics Symposium, Sao Paulo, Brazil, Springer-Verlag, 1974.
7. S. Bergamaschi, "Tether Motion after Failure," Journal of Astronautical Sciences, Vol. 30, No. 1, pp. 49-59, January-March 1982.

8. S. Bergamaschi, "A Review of Tether Induced Dynamical Features," Tether Applications in Space Workshop, Venice, Italy, October 15-17, 1985.
9. V. Chobotov, "Gravity-Gradient Excitation of a Rotating Cable-Counterweight Space Station in Orbit," Journal of Applied Mechanics, Vol. 30, pp. 547-554,.
10. G. Colombo, "Tether Dynamics Software Review, High Resolution Tether Dynamics, Advanced Tether Applications (Damping through Reel Motor Control; Payload Acquisition by Space Station)," NASA Contract NAS8-35036, Smithsonian Astrophysical Observatory, January 1984.
11. G. Colombo, "The Stabilization of an Artificial Satellite at the Inferior Conjunction Point of the Earth-Moon System," Smithsonian Astrophysical Observatory Special Report #8, 1961.
12. R. Farquhar, "The Control and Use of Libration Point Satellites," NASA TR R-346, Washington, DC, 1970.
13. J.R. Glaese and H.L. Pastrick, "Modal Synthesis Simulation of the Shuttle Orbiter Tethered Satellite System," AIAA/AAS Astrodynamics Conference, San Diego, AIAA-82-1424, 1982.
14. D.T. Greenwood, Principles of Dynamics, Prentice Hall, Inc., Englewood Cliffs, New Jersey, 1965.
15. G.E. Gullahorn, "Analytical Investigation and Simulation of Partially Tensioned Tethered Systems," Contract RH5-394202, Smithsonian Astrophysical Observatory, October 1985.
16. P. Hagedorn and S. Otterbein, "Some Remarks on the Control of Variable Length Tethered Satellites with Attitude-Orbit Coupling," Institut Fur Mechanik, T.J. Darmstadt, Darmstadt, Federal Republic of Germany.
17. M. Kammeyer and C. Soderland, "Spinning Dumbbells in Orbit," NASA/JSC, July 1985.
18. P. Kohler, W. Maag, R. Wehrli, R. Weber and H. Brauchi, "Dynamics of a System of Two Satellites Connected by a Deployable and Extensible Tether of Finite Mass," ESTEC Contract #2992/76/NL/AK(SC), Vol. 2, 1978.
19. P. Kohler, W. Maag, R. Wehrli, R. Weber and H. Brauchi, "Dynamics of a System of Two Satellites Connected by a Deployable and Extensible Tether of Finite Mass," ESTEC Contract #2992/76/NL/AK(SC), Vol. 1, 1978.
20. P. Kulla, "Dynamics of Tethered Satellites," Proceedings of the Symposium on Dynamics and Control of Non-Rigid Spacecraft, Frascati, Italy, 1976.

21. P. Kulla, "Stabilization of Tethered Satellites," ESTEC Report TMM/78-07/PK/AVS, 1977.
22. D.D. Lang, Tethered Object Simulation (TOSS) Reference Manual, NASA Contract NAS9-16715, September 1983.
23. K.W. Lips and V.J. Modi, "General Dynamics of a Large Class of Flexible Satellite Systems," ACTA ASTRONAUTICA, Vol. 7, pp. 1349-1360, 1980.
24. A.K. Misra and J.J. Modi, "Dynamics and Control of Tether Connected Two-Body Systems - A Brief Review," 33rd IAF Congress, Paris, France, September-October 1982.
25. C.D. Pengelley, "Preliminary Survey of Dynamic Stability of a Cable-Connected Spinning Space Station," Journal of Spacecraft, October 1966.
26. R. Pringle, "Exploration of Nonlinear Resonance in Damping an Elastic Dumbbell Satellite," AIAA Journal, No. 7, pp. 1217-1222, 1968.
27. H.P. Raabe, "Self-Stabilizing Satellite," US Patent 3,206,142, September 14, 1965.
28. M.H. Rheinfurth, et al., "Modal Analysis of a Non-Uniform String with End Mass and Variable Tension," NASA-TP-2198, August 1983.
29. V.A. Sarychev, "On the Dynamics of Tether-Connected Two-Body Systems," IAF-82-316, 33rd IAF Congress, Paris, France, September 27 - October 2, 1982.
30. J.L. Synge, "On the Behaviour, According to Newtonian Theory, of a Plumb Line or Pendulum Attached to an Artificial Satellite," Proceedings of the Royal Irish Academy, Vol. 60, Sec A, 1-6, 1959.
31. R.B. Singh, "Three Dimensional Motion of a System of Two Cable-Connected Satellites in Orbit," ACTA ASTRONAUTICA, Vol. 18, pp. 301-308, 1973.
32. W. Stuiver and P.M. Bainum, "A Study of Planar Deployment Control and Libration Dumping of a Tethered Orbiting Interferometer Satellite," Journal of Astronautical Sciences, Vol. 20, No. 6, pp. 321-346, May-June 1973.
33. W. Stuiver, "Lagrange Configurations in Space System Dynamics," Journal of the Astronautical Sciences, Vol. 25, pp. 91-106, 1977.
34. P.A. Swan, "Dynamics and Control of Tethers in Elliptical Orbits," IAF-84-361, presented at the 35th IAF Congress, Lausanne, Switzerland, October 1984.

35. C.J. Swet and J.M. Whisnant, "Deployment of a Tethered Orbiting Interferometer," Journal of Astronautical Sciences, Vol. 17, No. 1, pp. 44-59, Jul-Aug 1969.
36. C.J. Swet, "Method for Deploying and Stabilizing Orbiting Structures," US Patent 3,532,298, October 6, 1970.
37. E. Volterra and E.C. Zachmanoglou, Dynamics of Vibrations, Merrill Books, Ch. 4.3, 1965.
38. Symposium on Passive Gravity Gradient Stabilization, NASA SP-107, May 1965.
39. "Study of an Orbiting Dumbbell System Having Positive Orbital Energy," Contract NAS8-35497, Smithsonian Astrophysical Observatory, February 1985.
40. "Evaluation of Tether Dynamics and Control System Interaction," Final Report, NASA Contract NAS8-34667, June 30, 1983.

5.2.8.3 Materials Technology

1. C. Giari, et al., "Mechanisms of Degradation of Graphite Composites in a Simulated Space Environment," AIAA 21st Aerospace Sciences Meeting, AIAA-83-0590, January 1983.
2. G. Graff, "Superstrong Plastics Challenge Materials," High Technology, pp. 62-63, February 1985.
3. J.C. Halpin and J.L. Kardos, "Strength of Discontinuous Reinforced Composites: 1. Fiber Reinforced Composites," Polymer Engineering and Science, Vol. 19, No. 6, May 1978.
4. J.S. Hansen and R.C. Tennyion, "Simulated Space Environmental Effects on Fixed-Reinforced Polymeric Composites," AIAA 21st Aerospace Sciences Meeting, AIAA-83-0589, January 1983.
5. R.A. Holler, "Metallized Kevlar for Undersea Electromechanical Cables," Naval Air Development Center, Warminster, Pennsylvania, September 1984.
6. J.L. Kardos, "Structural/Property Relations and Inteface Effects in Short Fiber Reinforced Plastic," SESA-SPE Design and Testing of Composites Seminar, August 20, 1980.
7. R.E. Mauri and F.W. Crossonan, "Space Radiation Effects on Structural Composites," AIAA 21st Aerospace Sciences Meeting, AIAA-83-0591, January 1983.
8. D. Riggr and B. Sarkar, "Theoretical and Experimental Elastic Properties of Isotropic and Transversely Isotropic Silicon Carbide/Aluminum Composites," Third Silicon Carbide/Aluminum Technology Meeting, January 1981.

9. J.H. Ross, "Superstrength-Fiber Applications," Astronautics and Aeronautics, December 1977.
10. "New Resin Matrix for Composites Developed," Aerospace Engineering, pp. 6-13, November/December 1984.
11. "The Effect of Ultraviolet Light on Products Based on Fibers of Kevlar 29 and Kevlar 49 Aramid," information only on terrestrial applications, 1977.
12. "Kevlar 49 Aramid for Pultrusion," 1975.
13. "Characteristics and Uses of Kevlar 29 Aramid," 1976.
14. "Characteristics and Uses of Kevlar 49 Aramid High Modulus Organic Fiber," 1978.

5.2.9 Space Station

1. W.W. Anderson, "On Lateral Cable Oscillations of Cable-Connected Space Station," NASA TN 5107, NASA LaRC.
2. J.R. Arnold, J.A. Carroll, G. von Tiesenhausen, "An Investigation of Roles for Tethers on an Evolving Space Station," Final Report on NASA Grant NAG8-470 with the California Space Institute, University of California at San Diego, September 1985.
3. J.A. Carroll, "A Scenario for Tether Uses in a Space Station," AIAA/NASA Space Systems Technology Conference Paper 84-1110-CP, Costa Mesa, California Space Institute, June 5, 1984.
4. G. Colombo and J. Slowey, "On a New Concept for a Space Station Architecture," Appendix EII of Report on the Utilization of the External Tanks of the STS, California Space Institute, April 1983.
5. G. Colombo, "A Preliminary Study of the Orbiting Platform-Tether System Space Operation Center," Department of Aeronautics and Astronautics, Massachusetts Institute of Technology, 1980.
6. R. English "Characteristics of a Tethered Space Station," NASA LeRC, October 21, 1983.
7. D. Fester, K. Hamlyn, et al., "Tethered Orbital Refueling Study," NASA Contract NAS9-17059, Martin Marietta, January 1985.
8. P.M. Finnegan, "A Preliminary Look at Using a Tethered Wire to Produce Power on a Space Station," NASA LeRC, May 10, 1983.
9. K. Hamlyn, et al., "Tethered Orbital Refueling Study," NASA Contract NAS9-17059, Martin Marietta, October 1985, In Progress.
10. W. Nobles, "Space Station Requirements for Tether Applications," NASA Contract NAS8-35499, July 31, 1984.
11. P.A. Penzo, "Space Station Adaptability to Tether Applications," Proceedings 22nd Space Congress, Cocoa Beach, FL, April 23-26, 1985.
12. G. von Tiesenhausen, ed. "The Roles of Tethers on Space Station," NASA TM-86519, Marshall Space Flight Center, October 1985.
13. "Tether System Applications To/With Space Station," Unmarked Document, Approximately 1982.
14. "The Process of Space Station Development Using External Tanks," California Space Institute of the University of California, Scripps Institution of Oceanography, La Jolla, Report to Director of the Space Station Review Project, Office of Technology Assessment, March 11, 1983.

5.2.10 Planetary

1. H. Alfvén, "Spacecraft Propulsion: New Methods," Science, Vol. 176, pp. 167-168, April 14, 1972.
2. L. Bright, "Saturn Ring-Rendezvous Mission Utilizing a Tethered Sub-Satellite," JPL, Memorandum 312/84.8-938, May 7, 1984.
3. R. Farquhar, "The Utilization of Halo Orbits in Advanced Lunar Operations," NASA TN D-6365, Washington, DC, 1970.
4. J. Pearson, "Anchored Lunar Satellites for Cislunar Transportation and Communication," The Journal of Astronautical Sciences, Vol. 27, No. 1, pp. 39-62, January-March 1979.
5. J. Pearson, "Lunar Anchored Satellite Test," AIAA/AAS Astrodynamics Conference, Palo Alto, California, August 1978.
6. P.A. Penzo, "Tethers for Mars Space Operations," presented at "The Case for Mars II" Conference, University of Colorado, Boulder, Colorado, July 10-14, 1984.
7. P.A. Penzo and H.L. Mayer, "Tethers and Asteroids for Artificial Gravity Assist in the Solar System," AIAA Paper 84-2056, AIAA/AAS Astrodynamics Conference, Seattle, Washington, August 20-22, 1984.
8. "Planetary Technology: New Initiative Proposal," JPL, June 1984.

SECTION 6

CONTACTS

John Anderson
Office of Aeronautics and Space Technology
Code RS
NASA Headquarters
600 Independence Avenue, SW
Washington, DC 20546
(202) 453-2756

Alberto Anselmi
Aeritalia GSS
C.so Marche, 41
10146 Torino
Italy
(011) 3332356

D. A. Arnold
Smithsonian Astrophysical Observatory
60 Garden Street
Cambridge, MA 02138
(617) 495-7269

Peter M. Bainum
Howard University
Department of Mechanical Engineering
Washington, DC 20059
(202) 636-6612

William Baracat
General Research Corporation
7655 Old Springhouse Road
McLean, VA 22102
(703) 893-5900

Ivan Bekey
Code MT
NASA Headquarters
600 Independence Avenue, SW
Washington, DC 20546
(202) 453-1148

O. Bendiksen
Princeton University
Department of Mechanical and
Aerospace Engineering
Princeton, NJ 08544
(609) 452-5144

Douglas Bentley
Cortland Cable Co.
Port Watson Street
PO Box 330
Cortland, NY 13045-0330
(607) 753-8276

PRECEDING PAGE BLANK NOT FILMED

Silvio Bergamaschi
Institute of Applied Mechanics
Via Venezia 1
35131 Padova
Italy
(049) 8071968

Gianfranco Bevilacqua
Aeritalia
Corso Marche 41
10146 Torino
Italy
(011) 725089

Carl Bodley
Martin Marietta Corporation
Denver Aerospace
Mail Stop 8071
PO Box 179
Denver, CO 80201
(303) 977-3168

W. Bogo
Aeritalia GSS
Via Servais 125
Torino, Italy
(011) 3332356

Carlo Bonifazi
PSN-CNR
IFSI/CNR
Via Regina Margherita, 202
00198 Roma
Italy
(06) 40201

Alexander Boschitsch
Princeton University
Department of Mechanical & Aerospace Engineering
Princeton, NJ 08544
(609) 452-5909

Edward J. Brazill
NASA Headquarters
Code MT
600 Independence Avenue, SW
Washington, DC 20546
(202) 453-1155

John V. Breakwell
Stanford University
Department of Aeronautics/Astronautics
Stanford, CA 94305
(415) 723-3311

Larry Bright
Jet Propulsion Laboratory
Mail Stop 264-211
4800 Oak Grove Drive
Pasadena, CA 91109
(818) 393-7716

Don Brown
Johnson Space Center
National Aeronautics and Space Administration
Mail Stop EH3
Houston, TX 77058
(713) 483-3066

Carlo Buongiorno
PSN
Lungotevere Tamon De Revel, 76
00100 Roma
Italy
(06) 399718

George Butler
McDonnell Douglas Corporation
Director, Advanced Programs
Mail Stop 14-3
5301 Bolsa Avenue
Huntington Beach, CA 92647
(714) 896-3600

Cyrus L. Butner
General Research Corporation
7655 Old Springhouse Road
McLean, VA 22102
(703) 893-5900

Maurizio Candidi
IFSI/CNR
CP 27
00044 Frascati, Italy
(06) 9423801

Giovanni Carlomagno
Istituto Di Gasdinamica
P.le V. Tecchio, 80
80125 Napoli
Italy
(081) 635355 - 616276

Joseph Carroll
Energy Science Laboratories
11404 Sorrento Valley Road
#112
San Diego, CA 92121
(619) 452-7039

Salvatore Ciardo
Aeritalia
C.so Marche, 41
10146 Torino
Italy
(011) 3332356

Michael Cornell
Coopers and Lybrand
1800 M Street, NW
Washington, DC 20036
(202) 822-4045

George J. Corso
Indiana University Northwest
Physics and Astronomy
Gary, IN
(219) 980-6500

V. Davis
S. Cubed
PO Box 1620
La Jolla, CA 92038
(619) 453-0060

Luigi de Luca
Istituto Di Gasdinamica
P.le V. Tecchio, 80
80125 Napoli
Italy
(081) 616526 - 616276

Richard Deppisch
Johnson Space Center
National Aeronautics and Space Administration
Houston, TX 77058
(713) 525-4457

Marino Dobrowolny
Istituto Fisica Spazio Interplanetario
CNR CP27
00044 Frascati, Italy
(06) 9421017

Pamela Edwards
AIAA
1633 Broadway
New York, NY 10019
(212) 408-9778

Ruying Fan
Howard University
Department of Mechanical Engineering
Washington, DC 20059
(202) 636-7124

Dale A. Fester
Martin Marietta Corporation
Mail Stop MO441
PO Box 179
Denver, CO 80201
(303) 977-8699

Howard Flanders
Martin Marietta Denver Aerospace
Mail Stop S8071
PO Box 179
Denver, CO 80201
(303) 977-3974

Dwight Florence
General Electric Company
Reentry Systems Operations
PO Box 7722
Philadelphia, PA 19101
(215) 823-3129

Charles Gartrell
General Research Corporation
7655 Old Springhouse Road
McLean, VA 22102
(703) 893-5900

James Gearhart
Stanford University
Department of Aeronautics/Astronautics
Stanford, CA 94305
(415) 723-3317

Mireille Gerard
AIAA
1633 Broadway
New York, NY 10019
(212) 408-9770

Daniel Y. Gezari
NASA/Goddard Space Flight Center
Code 697
Greenbelt, MD 20771
(301) 286-3432

Vittorio Giavotto
Dipartimento Di Ingegneria
Aerospaziale
Politecnico Di Milano
Via Golgi 40
20133 Milano, Italy
(02) 2364308

John R. Glaese
Control Dynamics Co.
Office Park South, Suite 304
600 Boulevard South
Huntsville, AL 35802
(205) 882-2650

Ron Glickman
Ball Aerospace Systems
PO Box 1062
Boulder, CO 80306
(303) 939-4275

Filippo Graziani
Universita degli Studi di Roma
Dipartimento Aerospaziale
Roma
Italy
(06) 8120529

Michael Greene
University of Alabama
Electrical and Computer Engineering Department
Engineering Building
Huntsville, AL 35899
(205) 895-6463

Mario Grossi
Smithsonian Astrophysical Observatory
60 Garden Street
Cambridge, MA 02138
(617) 495-7433

Luciano Guerriero
Piano Spaziale Nazionale
Viale Regina Margherita 202
00100 Roma
Italy
(06) 8445107

Gordon Gullahorn
Smithsonian Astrophysical Observatory
Mail Stop 59
60 Garden Street
Cambridge, MA 02138
(617) 495-7419

Leonard Harris
National Aeronautics and Space Administration
Office of Aeronautics and Space Technology
Mail Code RS
Washington, DC 20546
(202) 453-2733

James K. Harrison
National Aeronautics and Space Administration
Marshall Space Flight Center
Code PS04
Marshall Space Flight Center, AL 35812
(205) 544-0629

D. Hastings
Massachusetts Institute of Technology
Department of Aeronautics and Astronautics
77 Massachusetts Avenue
Cambridge, MA 02139
(617) 253-0906

Xiaohua He
Aeronautics/Astronautics Department
Stanford University
Stanford, CA 94035
(415) 723-1431

Ira Katz
S Cubed
PO Box 1620
La Jolla, CA 92038
(619) 453-0060

Erlinda Kiefel
Martin Marietta
PO Box 179
Denver, CO 80201
(303) 977-8675

Joseph Kolecki
National Aeronautics and Space Administration
Lewis Research Center
Mail Stop 302-1
21000 Brookpark Road
Cleveland, OH 44135
(216) 433-2296

Kenneth Kroll
National Aeronautics and Space Administration
Johnson Space Center
Mail Code EP4
Houston, TX 77058
(713) 483-5495

David D. Lang
David D. Lang Associates
2222 70th Avenue, SE
Mercer Island, WA 98040
(206) 236-2579

Larry Lemke
NASA--Ames Research Center
Moffett Field, CA 94035
Mail Code 244-10
(415) 694-6531

Vincenzo Letico
Italian National Space Plan
950 L'Enfant Plaza
Room 3163
Washington, DC 20024
(202) 863-1298

George Levin
NASA Headquarters
Code MTF
Washington, DC 20546
(202) 453-1152

Lester Lippy
Martin Marietta Denver Aerospace
Mail Stop S8080
PO Box 179
Denver, CO 80201
(303) 977-3678

Enrico Lorenzini
Smithsonian Astrophysical Observatory
60 Garden Street
Cambridge, MA 02138
(617) 495-7211

Andrea Lorenzoni
Piano Spaziale Nazionale
Viale Regina Margherita 202
00195 Roma
Italy
(06) 4767249

Gianfranco Manarini
Piano Spaziale Nazionale
PSN/CNR
Viale Regina Margherita 202
00198 Roma
Italy
(06) 4767249

M. Mandell
S Cubed
PO Box 1620
La Jolla, CA 92038
(619) 453-0060

Franco Mariani
Dipartimento Fisica II Universita
V.D. Raimondo
00173 Roma, Italy
(06) 79792319

Lee S. Marshall
Martin Marietta Denver Aerospace
Mail Stop S-8071
PO Box 179
Denver, CO 80201
(303) 977-3225

Manual Martinez-Sanchez
Massachusetts Institute of Technology
Department of Aeronautics & Astronautics
77 Massachusetts Avenue
Cambridge, MA 02139
(617) 253-5613

M. Matteoni
Aeritalia
Corso Marche 41
10146 Torino
Italy
(011) 725089

Harris Mayer
30923 Cartier Drive
Rancho Palos Verdes, CA 90274
(213) 648-5426

James E. McCoy
Johnson Space Center
National Aeronautics and Space Administration
Mail Code SN3
Houston, TX 77058
(713) 483-5171

Dan McMann
Ball Aerospace Systems Division
Mail Code BE-9A
Boulder, CO 80306-1062
(303) 939-4376

Thomas Megna
Martin Marietta Denver Aerospace
Mail Stop S8071
PO Box 179
Denver, CO 80201
(303) 977-6870

Pietro Merlina
Aeritalia GSS
Via Servais 125
Torino
Italy
(011) 3332356

Arun K. Misra
McGill University
Department of Mechanical Engineering
817 Sherbrooke Street, W.
Montreal, Quebec, Canada H3A 2K6
(514) 392-5480

Antonio Moccia
Istituto Di Gasdinamica
Universita di Napoli
Ple Tecchio 80
80125 Italy
(081) 616276

V. J. Modi
Department of Mechanical Engineering
The University of British Columbia
2075 Westbrook Mall
Vancouver, British Columbia
Canada V6T 1W5
(604) 228-2914

Rodolfo Monti
Istituto Aerodinamica U. Nobile
Universita' di Napoli
Via Petrarca, 74
80100 Napoli
Italy
(81) 616526

Dave Moruzzi
Italian Advanced Industries (USA), Inc.
1235 Jefferson Davis Highway
Suite 500
Arlington, VA 22202
(703) 243-1700

David K. Mowery
Marshall Space Flight Center
National Aeronautics and Space Administration
Mail Code ED13
Marshall Space Flight Center, AL 35812
(205) 544-1444

Luigi Napolitano
Istituto Aerodinamica U. Nobile
Via F. Russo, 29
80123 Napoli
Italy
(081) 7690525

William O. Nobles
Martin Marietta Corporation
Denver Aerospace
Mail Stop S8071
PO Box 179
Denver, CO 80201
(303) 977-4302

Ralph Orban
Material Concepts, Inc.
666 North Hague Avenue
Columbus, OH 43204
(614) 272-5785

Thomas O. Paine
Thomas Paine Associates
10880 Wilshire Blvd.
Los Angeles, CA 90024
(213) 470-2904

Michael Patterson
NASA--Lewis Research Center
21000 Brook Park Road
Cleveland, OH 44135
(216) 433-2405

Jerome Pearson
AFWAL
Wright-Patterson Aeronautical Labs
Code AFWAL-FIBG
Wright-Patterson AFB, OH 45423
(513) 255-5236

Paul Penzo
Jet Propulsion Laboratory
Mail Code 156-217
4800 Oak Grove Drive
Pasadena, CA 91109
(818) 354-2797 (FTS 792)

David Powell
Aeronautics/Astronautics Department
Stanford University
Stanford, CA 94035
(415) 723-3425

Christopher R. Purvis
Jet Propulsion Laboratory
Mail Code 156-246
4800 Oak Grove Drive
Pasadena, CA 91109
(818) 354-8647

Carolyn Purvis
Spacecraft Environment Section
Code 5532
NASA--Lewis Research Center
21000 Brook Park Road
Cleveland, OH 44135
(216) 433-2307

L. Randolph
Martin Marietta
PO Box 179
Denver, CO 10802

Terrence G. Reese
General Research Corporation
7655 Old Springhouse Road
McLean, VA 22102
(703) 893-5900

Chris Rupp
National Aeronautics and Space Administration
Marshall Space Flight Center
Code PS04
Marshall Space Flight Center, AL 35812
(205) 544-0627

Cal Rybak
Ball Aerospace
PO Box 1062
Boulder, CO 80306
(303) 939-5462

Claire Savaglio
University of Michigan
Aerospace Engineering
3217 Harvard
Royal Oak, MI 48072
(313) 288-5668

Peter Scala
Cortland Cable Co.
Port Watson Street
PO Box 330
Cortland, NY 13045-0330
(607) 753-8276

Fred Schaff
Westinghouse Electric Corporation
Mail Stop 450
PO Box 746
Baltimore, MD 21203
(301) 765-4736

Silvano Sgubini
Universita degli Studi di Roma
Dipartimento Aerospaziale
Roma, Italy
(06) 8120529

Paul Siemers
National Aeronautics and Space Administration
Langley Research Center
Mail Stop 366
Hampton, VA 23665
(804) 865-3031

A. Sinopoli
Institute of Applied Mechanics
Via Venezia 1
35131 Padova
Italy
(049) 8071968

James Sisson
National Aeronautics and Space Administration
Marshall Space Flight Center
Mail Code FA31
Marshall Space Flight Center, AL 35812
(205) 453-5310

Richard Smith
Rocket Research Co.
11441 Willows Road
PO Box 97009
Redmond, WA 98073-9709
(206) 885-5000

R. V. Stachnik
Center for Astrophysics
Mail Stop 16
60 Garden Street
Cambridge, MA 02138
(617) 495-7347

Nobie Stone
National Aeronautics and Space Administration
Marshall Space Flight Center
Mail Code ES53
Marshall Space Flight Center, AL 35812
(205) 453-0029

Dale Stuart
Charles Stark Draper Laboratories
555 Technology Drive
Cambridge, MA 02139

Thomas Stuart
National Aeronautics and Space Administration
Office of Space Flight
Mail Code MST
Washington, DC 20546
(202) 453-1562

Giorgio Tacconi
Dipartimento Dibe Universita' Genova
Via dell'Opera Pia, 11 A
16145 Genova
Italy
(10) 311811

Richard Taylor
Smithsonian Center for Astrophysics
60 Garden Street
Cambridge, MA 02139
(617) 495-7425

Kip Thorne
Caltech
130-33
Pasadena, CA 91125
(818) 356-4598

Ernesto Vallerani
Aeritalia
C.so Marche 41
10146 Torino
Italy
(011) 712923

J. VanPelt
Martin Marietta Denver Aerospace
PO Box 179
Denver, CO 80201
(303) 977-4888

Sergio Vetrella
Facolta Di Ingegneria Ist. Gasdinamica
P.le Tecchini 80
80125 Napoli
Italy
(081) 616276

M. Vignoli
Aeritalia
Corso Marche 41
10146 Torino
Italy
(011) 725089

A. H. von Flotow
Stanford University
STARLab/SEL
Department of Electrical Engineering
Stanford, CA 94305
(415) 723-3532

Georg von Tiesenhausen
National Aeronautics and Space Administration
Marshall Space Flight Center
Mail Code PS01
Marshall Space Flight Center, AL 35812
(205) 544-0617

James D. Walker
Martin Marietta Corporation
PO Box 179, Mail Code L8010
Denver, CO 80201
(303) 977-2472

William J. Webster
Goddard Space Flight Center
National Aeronautics and Space Administration
Mail Code 622
Greenbelt, MD 20771
(301) 344-5554

P. R. Williamson
Stanford University
STARLab/SEL
Dept. of Electrical Engineering
Durand Building #202
Stanford, CA 94305
(415) 497-9774

Henry Wolf
Analytical Mechanics Associates
17 Research Drive
Hampton, VA 23666
(804) 865-0944

George Wood
National Aeronautics and Space Administration
Langley Research Center
Mail Code 234
Hampton, VA 23665
(804) 865-2466

W. Woodis
Martin Marietta Denver Aerospace
Mail Stop S8073
PO Box 179
Denver, CO 80201
(303) 977-4803