

REVISIONS			
SYMBOL	DESCRIPTION	DATE	APPROVAL
—	RELEASED	3/16/92	<i>[Signature]</i>

SHEET REVISION STATUS

SH	1	2	3	4	5	6	7	8	9	10	11	12	13	14	15	16	17	18	19	20
REV	--	--	--	--	--	--	--	--	--	--	--	--	--	--	--	--	--	--	--	--
SH	21	22	23	24	25	26	27	28	29	30	31	32	33	34	35	36	37	38	39	40
REV	--	--																		

ORIGINATOR T.J. Perry/Paramax	<i>T.J. Perry</i>	DATE 3/6/92	FSC: 5935
APPROVED S.E. Archer-Davies/Paramax	<i>[Signature]</i>	3/6/92	Connectors, Electrical, Rectangular, Polarized Shell, EMI Shielding (Size 2) For Space Flight Use, Detail Specification For
CODE 311 APPROVAL S.A. Naus/GSFC	<i>[Signature]</i>	3/9/92	
CODE 311 SUPERVISORY APVL G.P. Kramer, Jr./GSFC	<i>[Signature]</i>	3/16/92	
ADDITIONAL APPROVAL			S-311-P-718/5

NATIONAL AERONAUTICS AND SPACE ADMINISTRATION
 GODDARD SPACE FLIGHT CENTER
 GREENBELT, MARYLAND 20771

CAGE CODE: 25306 PAGE 1 OF 22

1. SCOPE

1.1 Specification for connectors. This specification covers the detail provisions for rectangular, polarized shell, electrical connectors, capable of continuous operation in a space environment within a temperature range from -65°C to +125°C. Connectors use rear-insertion and rear-release crimp-type contacts, supplied separately. Detail specification GSFC S-311-P-718/2 covers the contacts for the electrical connectors. The connectors shall be designed to be used with the appropriate EMI backshells furnished under GSFC S-311-P-718/4.

1.2 GSFC general specification. Unless otherwise noted, all connector provisions and requirements of GSFC general specification S-311-P-718 apply to this specification.

1.3 Connector - type designations. Connectors shall be of the following type designations, and shall be ordered by their type designations only.

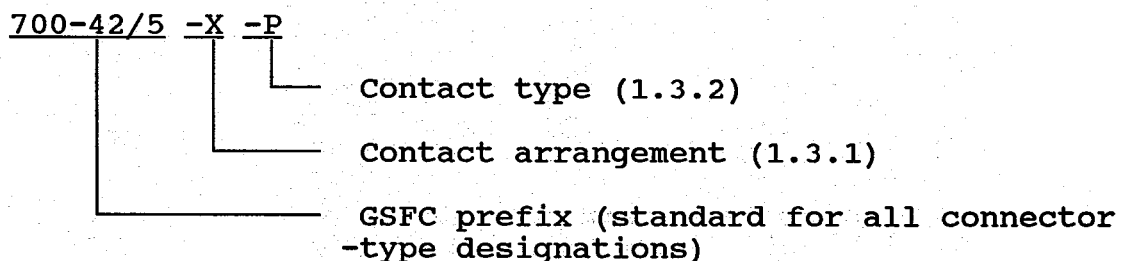

1.3.1 Contact arrangement. Select the contact arrangement from Figure 1.

1.3.2 Contact Type. Select the contact type: P for pin; S for socket (Note: Plug-type connectors are available with socket-type contacts only while receptacles are equipped with pin-type contacts (See Figure 2)).

2.0 APPLICABLE DOCUMENTS (1.2)

The following documents, of the issue in effect on date of invitation for bids or request for proposal, form a part of this specification to the extent specified herein.

2.1 Specifications.

2.1.1 Federal.

QQ-A-200/8	Aluminum Alloy Bar, Rod, Shapes and Tube, Extruded, 6061 and 6062
QQ-A-250/11	Aluminum Alloy 6061, Plate and Sheet

QQ-C-533 Copper, Beryllium Alloy Strip (Copper Alloy Numbers 170 and 172)

ZZ-R-765 Rubber, Silicone, Low and High-Temperature and Tear Resistant

2.1.2 Military.

MIL-C-26074 Coatings, Electroless Nickel, Requirements for

MIL-C-17 Cables, Radio Frequency; Coaxial, Dual Coaxial, Twin Conductor, and Twin Lead

MIL-W-16878 Wire, Electrical, Insulated, High Temperature

MIL-C-22520 Crimping Tools, Contact, Electric, Hand, General Specification for

MIL-T-22910 Tool, Crimping, Hand, for Crimp Style Electric Terminal and Shield Ferrule

MIL-I-43553 Ink, Marking, Epoxy Base

MIL-G-45204 Gold Plating, Electrodeposited

MIL-C-81511 Connectors, Electrical, Circular, High Density, Quick Disconnect, Environment Resisting, and Accessories, General Specification for

MIL-C-14550 Copper Plating (Electrodeposited)

2.1.3 NASA/GSFC.

GSFC S-311-P-718 Connectors, Electrical, Rectangular (Power and Coaxial Contacts) (Including EMI Shielding) for Space Flight Use, General Specification for

GSFC S-311-P-718/2 Contacts, Power and Coaxial, Removable, (Sizes 1, 2 and 3) for Electrical Connectors

GSFC S-311-P-718/4 Backshell Kits, Connector, Rectangular, EMI Shielding, Strain Relief (Sizes 1, 2, 3) for Space Flight Use, Detail Specification for

2.2 Standards.

MS3187	Plug, End Seal, for MIL-C-26482, MIL-C-5015, MIL-C-81703 and MIL-C-83723 Electrical Connectors
MS3197	Gage Pin, for Socket Engagement Test
MS27488	Plug, End Seal, Electrical Connector
DOD-STD-100	Engineering Drawing Practices

2.3 Order of precedence. The order of precedence delineated in the general specification shall apply.

3. REQUIREMENTS (1.2)

3.1 Materials, design, and construction. Connectors shall be of the materials, design, construction, and physical dimensions as specified herein (Figures 1 and 2). They shall be constructed to accommodate removable crimp-type power and coaxial contacts conforming to specification GSFC S-311-P-718/2. (Reference: Finishes not specified, which are known to sublime in a hard vacuum, such as cadmium, shall not be used.) Connectors shall be designed to be mated when the distance between the plug and receptacle is achieved as indicated in Figure 2A and Figure 2B.

3.1.1 Material weight loss (vacuum). Connector materials used shall be such that in no case will outgassing limits of 3.2.3 be exceeded when tested in accordance with GSFC S-311-P-718.

3.1.2 Insert material. Inserts shall be made of Epiall 1908 or Epiall 1914. The inserts shall meet the material weight loss requirement of 3.1.1.

3.1.3 Contact designation. Contact locations (numerals) shall appear on the front and rear faces of inserts to identify the contacts (Figure 1). The socket identification shall correspond to the mating-pin contact identification.

3.1.4 Shell design. The shell shall be designed to positively retain the insert and be so constructed that the insert cannot be removed without the use of tools. Shells shall be scoop-proof and shall be chamfered at the mating surfaces. The connector shall be so designed that a single shell configuration pair will accommodate either contact arrangement (Figure 1). Flange location shall be as indicated in Figure 2.

3.1.4.1 Shell polarization Polarization shall be accomplished by a shaped-shell design. Polarization shall be accomplished before engagement of the contacts.

3.1.4.2 Shell material and finish. The shells shall be made of aluminum alloy in accordance with QQ-A-200/8, 6061-T6511, or QQ-A-250/11, 6061-T651. The connector's shell surface shall be nickel plated per MIL-C-26074, Class 4, Grade B. A blue painted alignment stripe and alignment line shall be located per Figures 2A and 2B. The paint shall be per MIL-I-43553, Type I. The paint shall meet the weight loss requirements of 3.1.1.

3.1.4.3 Shell spring fingers. Spring fingers shall be designed to make electrical contact with the mating shell without interfering with proper engagement. The fingers shall be positively retained about the shell periphery per Figure 2A. Spring finger shall be made from beryllium copper alloy in accordance with QQ-C-533. Finger plating shall be gold plated per MIL-G-45204, Type II, Class II, Grade C, over Type I, Class I, Grade A over copper flash per MIL-C-14550 .00001 - .00010" thick.

3.1.5 Connector mating/demating tooling. The supplier shall design and/or recommend the required tooling necessary for connector mating/demating.

3.1.6 Contact retention clips. Contact retention clips shall be heat treated to a hardness of 65,000 psi. The clip material shall be beryllium copper.

3.1.7 Interfacial seal. All pin contact inserts shall have a resilient interface seal bonded to the front face, with individual pin barriers. The pin barrier projections shall seal in their respective lead-in chamfers of the hard face socket insert. The resilient interfacial seal shall provide individual contact seals in the mated condition to ensure circuit isolation between each contact and contact to shell. The interfacial seal shall meet the material weight loss requirement of 3.1.1.

3.1.8 Wire sealing member (rear grommet). A wire sealing member shall be provided on the rear of both the plug and receptacle and it shall not be removable from the connector. It shall be designed to provide sealing to meet the environmental requirements of this specification when using wire of outer diameters within the range shown below. When wires of smaller diameter are specified, (e.g., for qualification) the use of shrink-fit tubing is permitted, as required. The grommet shall meet the material weight loss requirement of 3.1.1. The grommet shall be of a triple-gland design.

**Finished Wire Outside Dimensions
(in.)**

<u>Contact Cavity</u>	<u>Wire Size</u>	<u>Min.</u>		<u>Max.</u>
16	16-18-20(1)	0.064	-	0.095
RG-122/U	RG-122/U(2)	0.155	-	0.165
20	20-22-24(1)	0.050	-	0.072
22	22-24-26(1)	0.045	-	0.064
Triax	9530D5117(3)	0.142	-	0.158
Data Bus	51-05091(4)	0.155	-	0.163
Coax (RG 142B/U)	RG-142B/U(2)	0.190	-	0.200

- (1) MIL-W-16878, type EE
 (2) MIL-C-17
 (3) Raychem FSCM 06090
 (4) Champlain Cable, Inc. FSCM 05973

3.1.9 Sealing plugs. The same sealing plugs shall be capable of being used in both connector plugs and receptacles. The sealing plug identification shall be as follows:

MS27488-8	For triax, coax (RG-142B/U), data bus grommet cavity
MS3187-16	For size 16 grommet cavity
MS3187A-20	For size 20 grommet cavity
MIL-C-81511/15-22	For size 22 grommet cavity
MS27488-4	For RG-122/U grommet cavity

3.1.10 Angular connect and disconnect capability. The connector pairs, when suitably mounted with one connector half on a floating, spring supported plate, must be capable of engagement or separation without binding, degradation or jamming and without exceeding acceptable force limits when the two connector mounting surfaces are engaged or separated at angles of up to +10° combined with a +0.12 in. misalignment.

3.1.11 Connector weight. The maximum weight of each connector half including a full complement of contacts, minus the backshells, shall be in accordance with Figures 1A and 1B.

3.1.12 Coaxial contact installation. Coaxial (RG-122/U) plug contacts shall only be installed in plug connector halves. Coaxial (RG-122/U) receptacle (jack) contacts shall only be installed in receptacle connector halves. Coaxial (RG-142B/U), data bus and triaxial plug contacts shall only be installed in receptacle connector halves. Coaxial (RG-142B/U) data bus and triaxial (jack) contacts shall only be installed in plug connector halves.

3.2 Performance (1.2).

3.2.1 Dielectric withstanding voltage. The applicable dielectric withstanding voltage shall be in accordance with Table I.

Table I. Dielectric withstanding voltage.

	ac V (rms) 60 Hz	
	Sea Level	70,000 ft.
Size 16, 20 or 22 contact-to-contact and contact-to-shell	1000	350
Coaxial, triaxial and data bus outer contact-to-shell; coaxial outer contact-to-nearest Size 16, 20 or 22 contact	1000	350
Coaxial outer contact-to-coaxial center contact	1000	350
Triaxial and data bus center contact to either outer contact and between outer contacts	1000	350

.2.2 Contact retention (in insert). The applicable axial load shall be in accordance with Table II.

Table II. Contact retention.

Contact Type	Force in lb (min.)
Size 16	25
Coaxial (RG-122/U)	25
Size 20	15
Size 22	10
Coax (RG-142B/U), Triax, Data Bus	25

3.2.3 Vacuum effects (material outgassing). The material outgassing limits of the insert, interfacial seal and grommet individually shall not exceed 1.0 percent in total weight loss and 0.1 percent in volatile-condensable material.

3.2.4 Contact resistance. The contact resistance shall not exceed the limits of Table III.

Table III Voltage drop.

Contact Wire Size	Wire Size	Test Current (Amperes)	Voltage Drop (mV max)	Voltage Drop (mV max) After Durability
Size 16-1/16		13	49	59
Size 20-1/20		7.5	55	66
Size 22-1/22		5.0	73	88

3.2.5 Insert retention (in shell). The applicable load shall be 60 lb per square in. (psi).

3.2.6 Connector mating and demating forces. The connectors shall not exceed the forces listed in Table IV.

Table IV. Connector mating and demating forces.

Contact Arrangement	Force in lb (max)	
	Mating	Demating
No. 1	100	100
No. 2	100	100

3.2.7 Contact engagement and separation. Contacts shall conform to the forces in Table V. Test pins shall be in accordance with MS3197, except as noted.

Table V. Contact engaging and separating forces.

	Engag- ing	Separat- ing	Test Pin	
	Max.	Min.	Min.	Max.
Size 16	20.0	2.0	MS3197-16X1	MS3197-16Y1
Size 20 Size 22	18.0 12.0	0.75 0.75	MS3197-20X1 MS3197-22X1	MS3197-20Y1 MS3197-22Y1
Coax. (RG-122/U) (Center contact)	14.0	0.5	.0345+.0001 -.0000	.0365+.0000 -.0001
Coax. (RG-122/U) (Outer contact)	60.0	2.0	.217 +.0001 -.0000	.219 +.0000 -.0001
Coax. (RG-142B/U) (Center contact)	14.0	0.4	.0235+.0001 -.0000	.0245+.0000 -.0001
Coax. (RG-142B/U) (Outer contact)	60.0	2.0	.2170+.0001 -.0000	.2190+.0000 -.0001
Coax. (RG-122/U) (Center contact)	14.0	0.5	.0345+.0001 -.0000	.0365+.0000 -.0001
Triax (Center contact)	14.0	0.4	.0235+.0001 -.0000	.0245+.0000 -.0001
Triax (Middle contact)	30.0	2.0	.112 +.0001 -.0000	.114 +.0000 -.0001
Triax (Outer contact)	60.0	2.0	.2170+.0001 -.0000	.2190+.0000 -.0001
Data Bus (Center contact)	14.0	0.4	.0235+.0001 -.0000	.0245+.0000 -.0001
Data Bus (Middle contact)	14.0	0.5	.112 +.0001 -.0000	.114 +.0000 -.0001
Data Bus (Outer contact)	60.0	2.0	.2170+.0001 -.0000	.2190+.0000 -.0001

3.2.8 Moisture resistance. Connectors shall meet the dielectric withstanding voltage, when tested as specified in 4.1.2, and the applicable insulation resistance as follows:

- a. After step 6(c), the insulation resistance shall be 1 megohm, min.
- b. After 24 hours, (g), the insulation resistance shall be 1,000 megohms.

4. QUALITY ASSURANCE PROVISIONS (1.2)

4.1 Quantity of samples for qualification. The quantity of connector samples for each connector type designation desired for qualification shall be two, minimum, together with their counterpart connectors and equipped with appropriate EMI shielding backshells per GSFC S-311-P-718/4. The connectors shall have their full complement of contacts. The connector type designation shall be specified.

4.1.1 Connector wiring. The power contacts shall be wired using wire per specification MIL-W-16878, (Type E) or (Type EE) as follows: Note: The percentages listed are only approximate; however, all contact cavities shall be filled.

Contact Arrangement			
No. 1		No. 2	
Size 16-1	AWG 16-25%	Size 16-1	AG 16-25%
	20-25%		20-25%
16-2	22-25%	16-2	22-25%
	26-25%		26-25%
20-1	AWG 20-50%	20-1	AWG 20-50%
	24-50%		24-50%
22-1	AWG 22-50%		
	24-50%		
Coaxial (RG-122/U) (1)	-100%	Coax RG-142B/U(1)	50%
		Triaxial-953D5117(2)	50%
		Data Bus-51-05091(3)	0%

(1) MIL-C-17

(2) Raychem FSCM 06090

(3) Champlain Cable Inc. FSCM 05973

4.1.2 Moisture resistance. Mated connectors shall be subjected to the moisture-resistance test as specified in the general specification (1.2), except when modified as in 3.2.8.

- a. After completion of the sixth step of the final cycle and after removal of surface moisture from the insulator, the insulation resistance shall be measured while observing the limit of 3.2.8(a).
- b. The sea-level dielectric-withstanding-voltage test shall be sustained with 600 V ac (rms) 60 Hz applied.
- c. After the 24-hour conditioning period, the insulation resistance shall again be measured while observing the limit of 3.2.8(b).

4.2 Final inspection. Connectors final inspection shall consist of these examinations, inspections, and tests:

- a. Each connector shall be 100 percent inspected per the workmanship provisions of the general specification, per GSFC S-700/42.
- b. Each connector shall be checked for:
 1. Critical Dimensions (per applicable figure)
 2. Weight (3.1.11)
 3. Mating and Demating Test (3.2.6)
 4. Contact Retention Test - all contacts (3.2.2)
 5. Electricals
 - a. DWV (3.2.1)
 - b. IR (3.6.1-General Specification)

5. PREPARATION FOR DELIVERY (1.2)

6. NOTES (1.2)

Custodian:

Code 311.2
Goddard Space Flight Center
Greenbelt, MD 20771

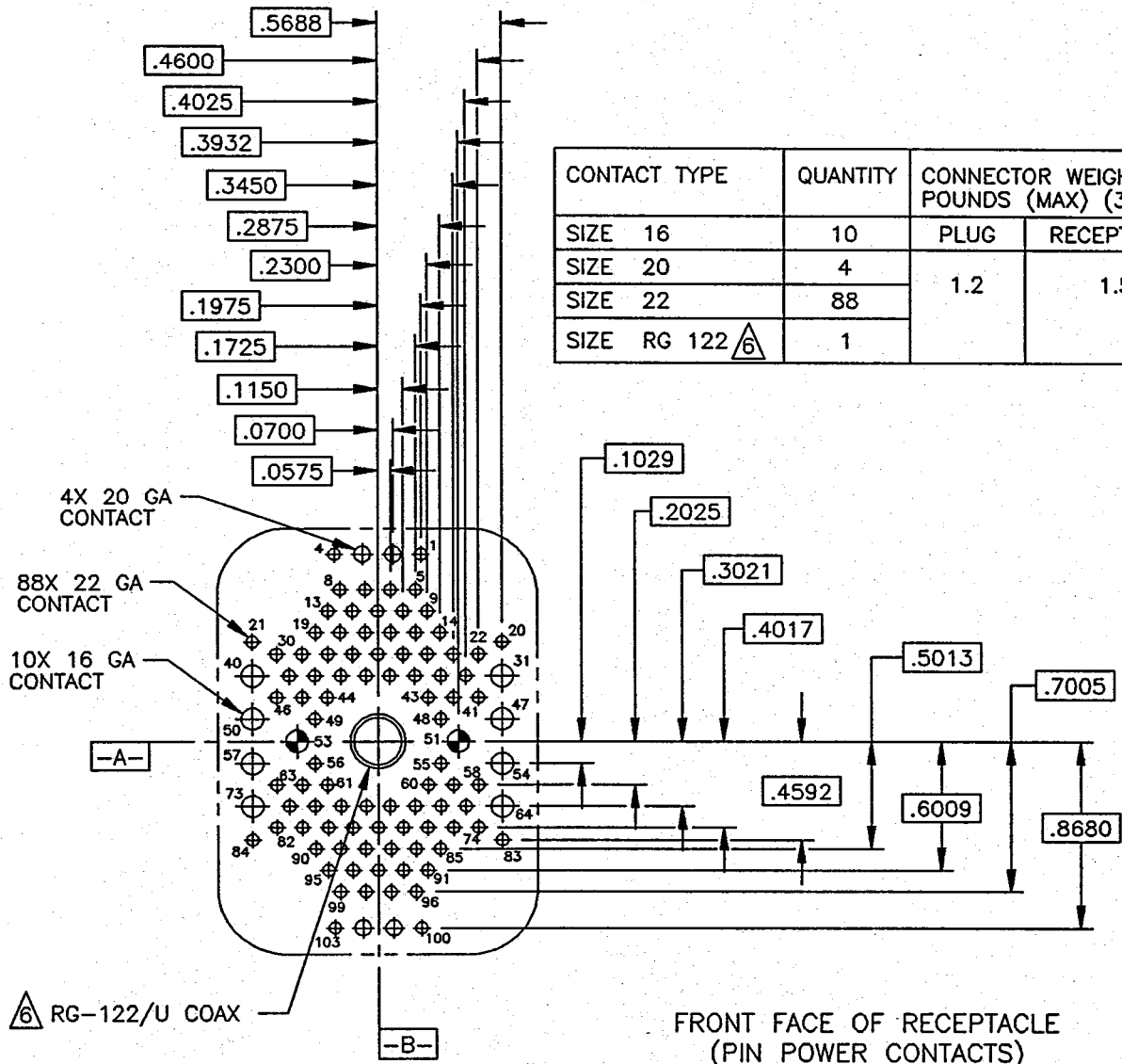

NOTES: UNLESS OTHERWISE SPECIFIED.

1. INTERPRET PER DOD-STD-100.
 2. DIMENSIONS AND IMPLIED 90° ANGLES ARE BASIC.
 3. THE CENTER LINES OF CAVITIES INDICATED \oplus ARE LOCATED ON DATUM PLANE -A-.
 4. THE CAVITIES INDICATED \ominus ARE LOCATED SYMMETRICALLY ABOUT DATUM PLANE -B-.
 5. DIMENSIONS ARE SYMMETRICAL ABOUT -A- AND -B-.
- \triangle 6 FOR REFERENCE ONLY. NOT SPACE COMPATIBLE. CANDIDATE REPLACEMENT CABLE TBD.

FIGURE 1A - CONTACT ARRANGEMENT-1

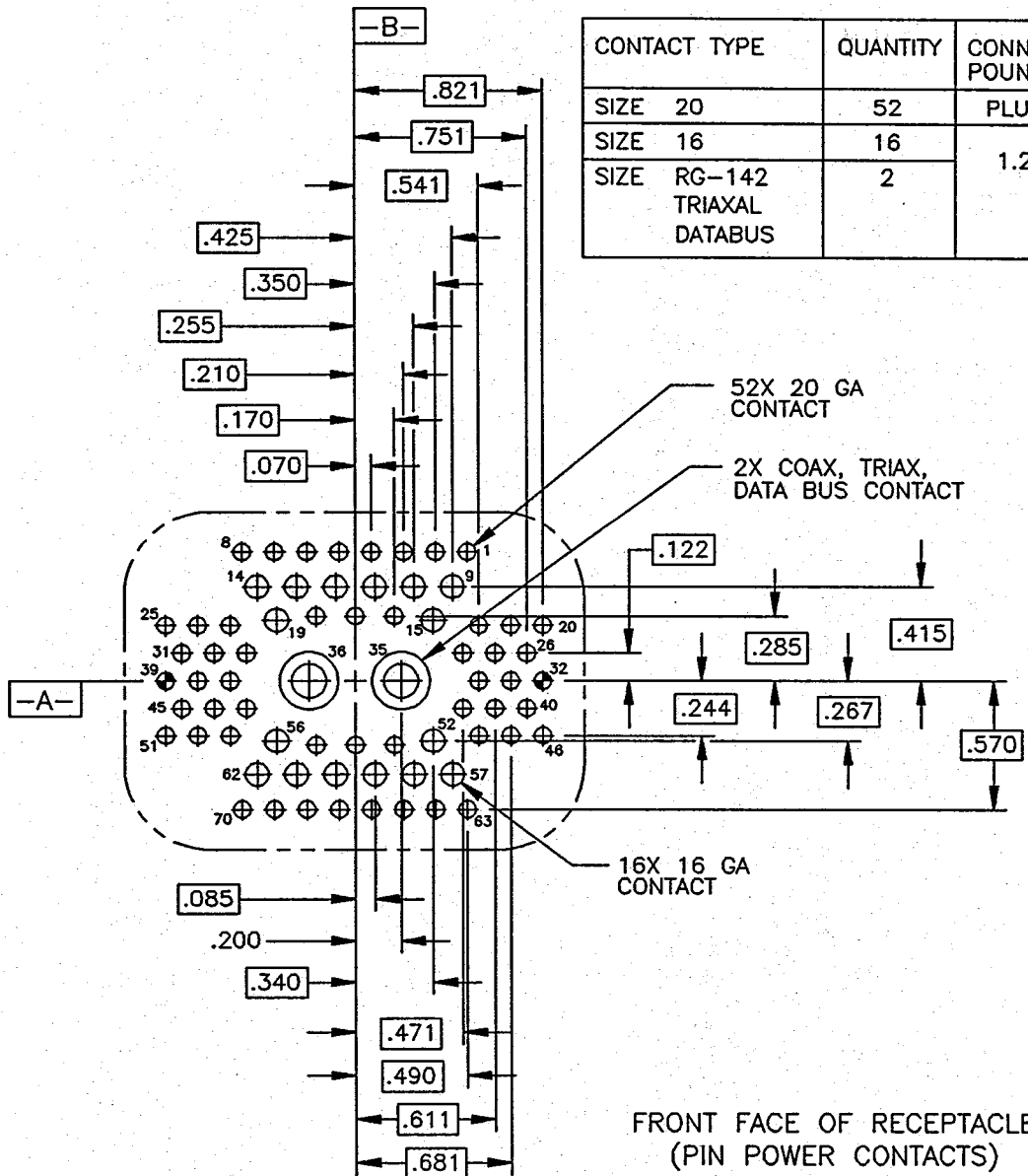

FRONT FACE OF RECEPTACLE
(PIN POWER CONTACTS)

NOTES: UNLESS OTHERWISE SPECIFIED.

1. INTERPRET PER DOD-STD-100.
2. DIMENSIONS AND IMPLIED 90° ANGLES ARE BASIC.
3. THE CENTER LINES OF CAVITIES INDICATED \oplus ARE LOCATED ON DATUM PLANE -A-.
4. THE CAVITIES INDICATED \oplus ARE LOCATED SYMMETRICALLY ABOUT DATUM PLANE -B-.
5. DIMENSIONS ARE SYMMETRICAL ABOUT -A- AND -B-.

FIGURE 1B - CONTACT ARRANGEMENT-2

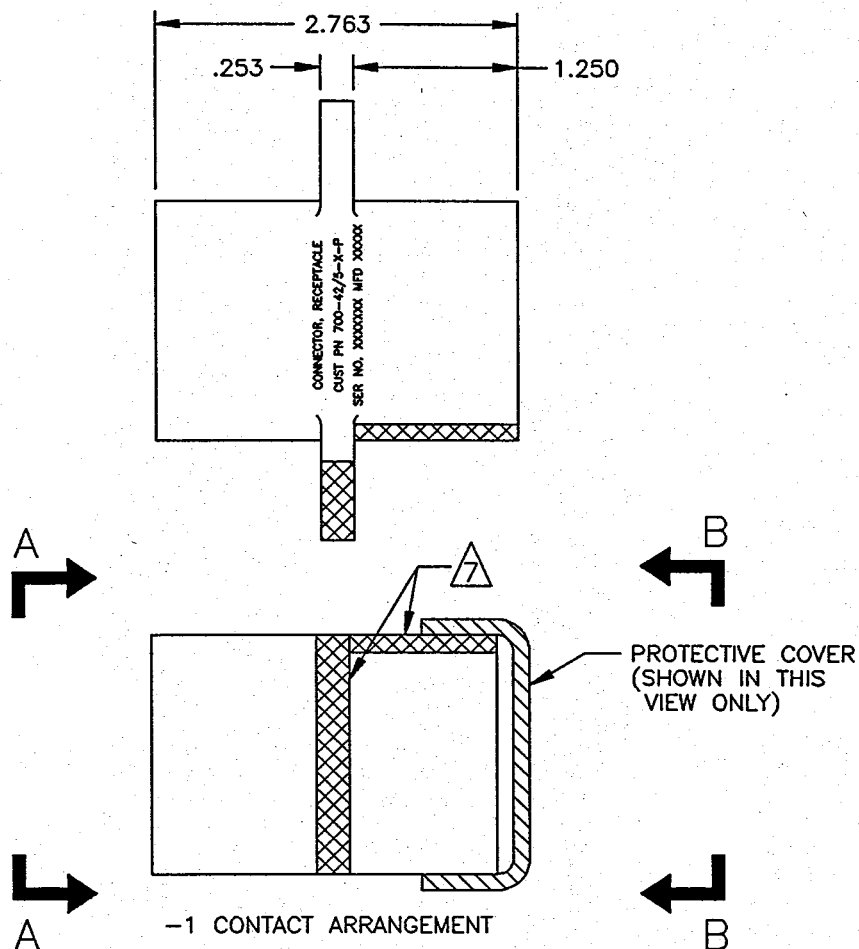

NOTES: UNLESS OTHERWISE SPECIFIED.

1. INTERPRET PER DOD-STD-100.

② G&H TECHNOLOGY, CAGE CODE 99447.

③ ASTRO TOOL CO., CAGE CODE 58164 (FORMERLY BUCHANAN CRIMP TOOL PRODUCTS).

④ DATABUS (TWINAX) CABLE, PN51-05091, MAY BE PURCHASED FROM CHAMPLAIN CABLE INC., CAGE CODE 05975.

⑤ TRIAX CABLE, PN9530D5117 MAY BE PURCHASED FROM RAYCHEM CORP., CAGE CODE 06090.

⑥ DANIELS MANUFACTURING CO., CAGE CODE 11851.

⑦ BLUE COLOR BANDS ARE FOR VISUAL ALIGNMENT PRIOR TO MATING.

8. THIS CONNECTOR IS DESIGNED TO FUNCTION IN CONJUNCTION WITH EMI BACKSHELL KIT PER GSFC S-311-P-718/4.

FIGURE 2A - CONNECTOR CONFIGURATION, RECEPTACLE, ELECTRICAL, RECTANGULAR CONTACT ARRANGEMENT-1
USE FOR CONTACT NUMBER IDENTIFICATION
(PAGE 1 OF 4)

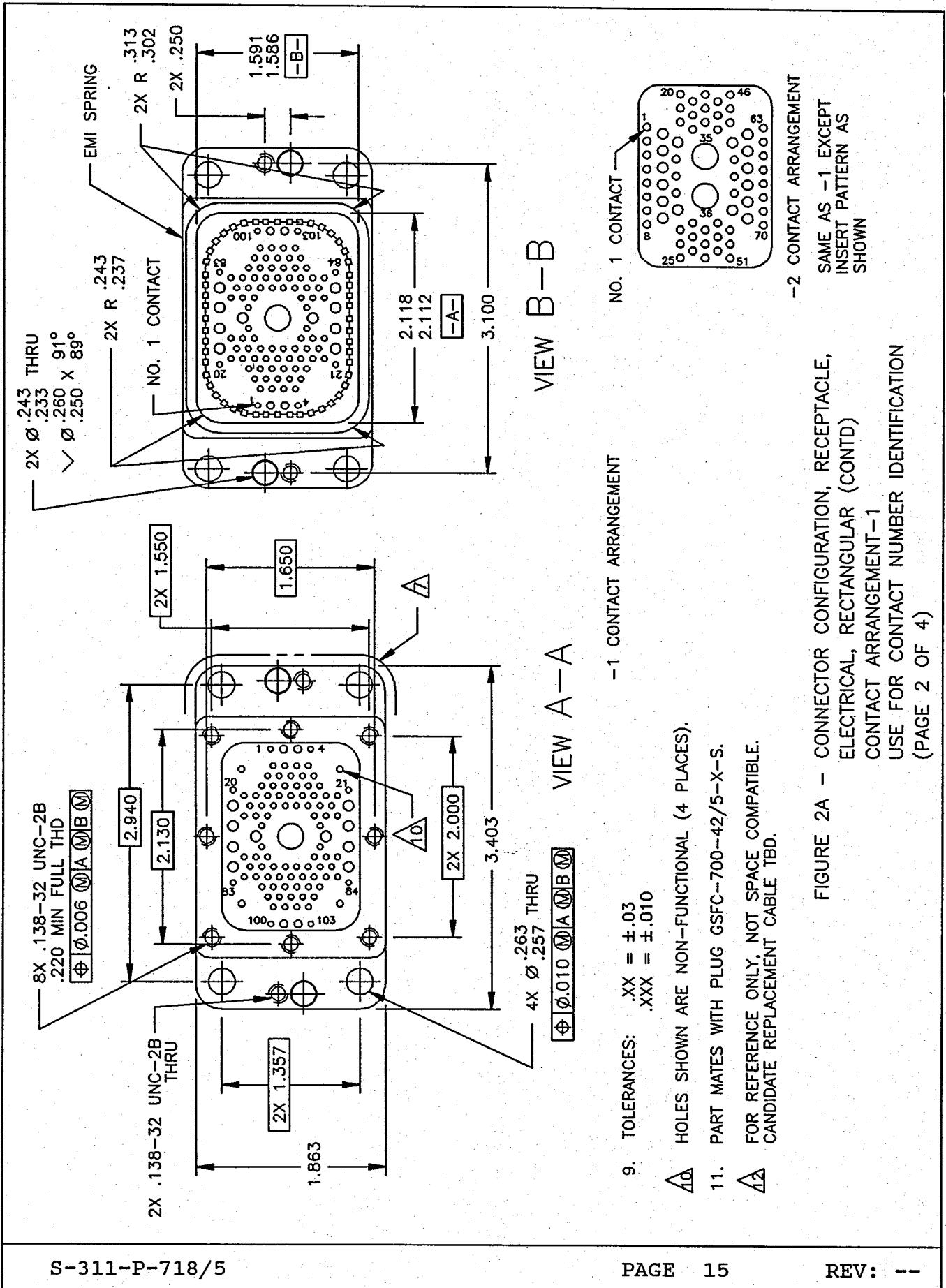

-1 CONTACT ARRANGEMENT

NO. 1 CONTACT

- 9. TOLERANCES: .XX = ±.03
.XXX = ±.010

△ Holes shown are non-functional (4 places).

11. Part mates with plug GSFC-700-42/5-X-S.

△ For reference only, not space compatible. Candidate replacement cable TBD.

-2 CONTACT ARRANGEMENT

FIGURE 2A - CONNECTOR CONFIGURATION, RECEPTACLE, ELECTRICAL, RECTANGULAR (CONTD)
CONTACT ARRANGEMENT-1
USE FOR CONTACT NUMBER IDENTIFICATION
(PAGE 2 OF 4)

SAME AS -1 EXCEPT INSERT PATTERN AS SHOWN

MATED VIEW

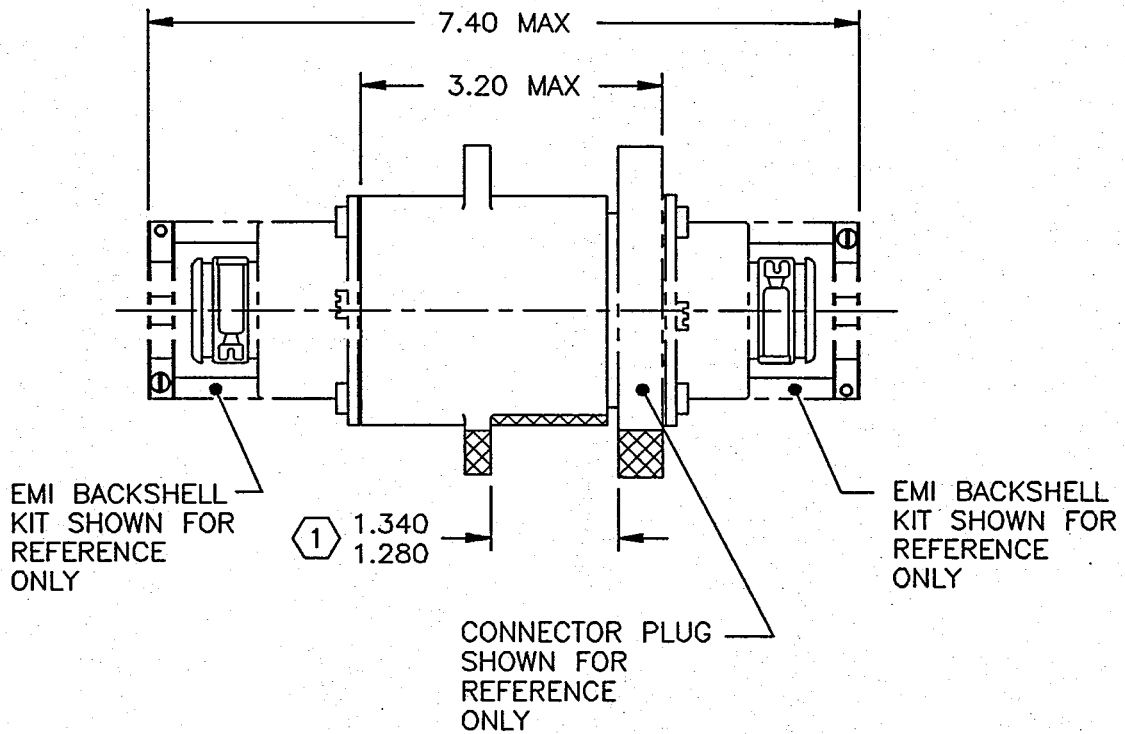

1 CONNECTOR IS MATED WHEN DISTANCE NOTED BETWEEN FLANGES IS ACHIEVED

FIGURE 2A - CONNECTOR CONFIGURATION, RECEPTACLE, ELECTRICAL, RECTANGULAR (CONTD)
(PAGE 3 OF 4)

CONTACT SIZE	WIRE OR CABLE SIZE	CONTACT SOCKET PART NO.	COLOR CODE	SEALING PLUG PART NO.	CRIMP TOOL NO.	POSITIONER, LOCATOR OR DIE NO.	REMOVAL TOOL NO.	INSERTION TOOL NO.	PUSH TOOL NO.	CONNECTOR SEPARATING TOOL NO.	CONNECTOR MATING TOOL NO.
22	22-24-26	GPP25	BLUE/WHITE (2 BANDS)	MIL-C-81511/15-22	612118	615507	998-377-001	998-377-006	998-299-C0T0		
20	20-22-24	GPP24	GREEN/WHITE (2 BANDS)	MS3187A20	M22520/1-01	M22520/1-02	998-377-002	998-377-005	998-300-C0T0		
16	16-18-20	GPP22	BLUE/YELLOW (2 BANDS)		M22520/1-01	M22520/1-02					
	22-24-26	GPP23	BLUE/RED (2 BANDS)	MS3187-16	M22520/7-01	M22520/7-04	998-377-003	998-377-004	882-91-001		
RG 142 B/U COAX	M17/060	GCP28	GREEN (1 BAND)								882-60-001 (2 REQ'D)
TRIAX		GTP26	YELLOW (1 BAND)	MS27488-8	M22520/2-01 AND M22520/5-01	K709 AND K631	998-388-001	NOT REQUIRED	NOT REQUIRED		
DATABUS (TWINAX)		GDP27	BLACK (1 BAND)								
RG 122/U COAX	M17/54	GCS29	NONE	MS27488-4	M22520/5-01	M22520/5-05	998-142-001	NOT REQUIRED	NOT REQUIRED		

CONTACT SIZE	CONTACT PATTERN IDENTIFICATION NUMBER	
	CONTACT SIZE	
22	GSFC 700-42/5-2-P	
20	NONE	
16	1 THRU 8, 16 THRU 18, 20 THRU 34, 37 THRU 51, 53 THRU 55, 63 THRU 70	
RG 142 B/U COAX	9 THRU 15, 19, 52, 56 THRU 62	
TRIAX		
DATABUS (TWINAX)	35 AND 36	
RG 122/U COAX	NONE	

FIGURE 2A - CONNECTOR CONFIGURATION, RECEPTACLE, ELECTRICAL, RECTANGULAR (CONTD) (PAGE 4 OF 4)

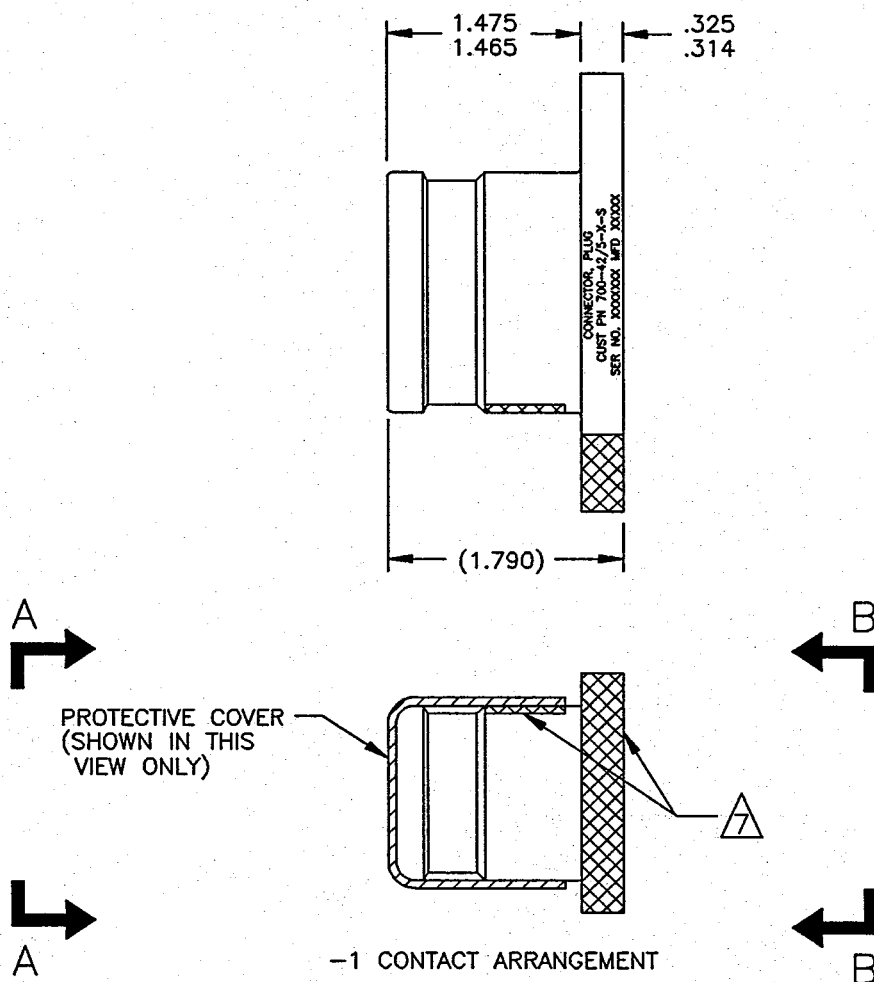

NOTES: UNLESS OTHERWISE SPECIFIED.

1. INTERPRET PER DOD-STD-100.
- ② G&H TECHNOLOGY, CAGE CODE 99447.
- ③ ASTRO TOOL CO., CAGE CODE 58164 (FORMERLY BUCHANAN CRIMP TOOL PRODUCTS).
- ④ DATABUS (TWINAX) CABLE, PN51-05091, MAY BE PURCHASED FROM CHAMPLAIN CABLE INC., CAGE CODE 05975.
- ⑤ TRIAX CABLE, PN953005117 MAY BE PURCHASED FROM RAYCHEM CORP., CAGE CODE 06090.
- ⑥ DANIELS MANUFACTURING CO., CAGE CODE 11851.
- ⑦ BLUE COLOR BANDS ARE FOR VISUAL ALIGNMENT PRIOR TO MATING.
8. THIS CONNECTOR IS DESIGNED TO FUNCTION IN CONJUNCTION WITH EMI BACKSHELL KIT PER GSFC S-311-P-718/4.

FIGURE 2B - CONNECTOR CONFIGURATION, PLUG, ELECTRICAL, RECTANGULAR
(PAGE 1 OF 5)

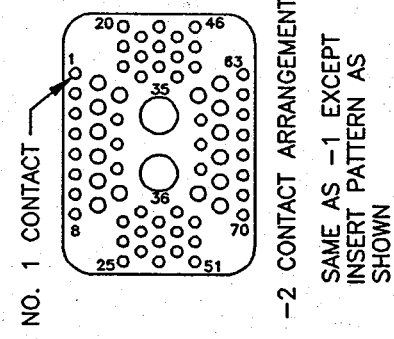
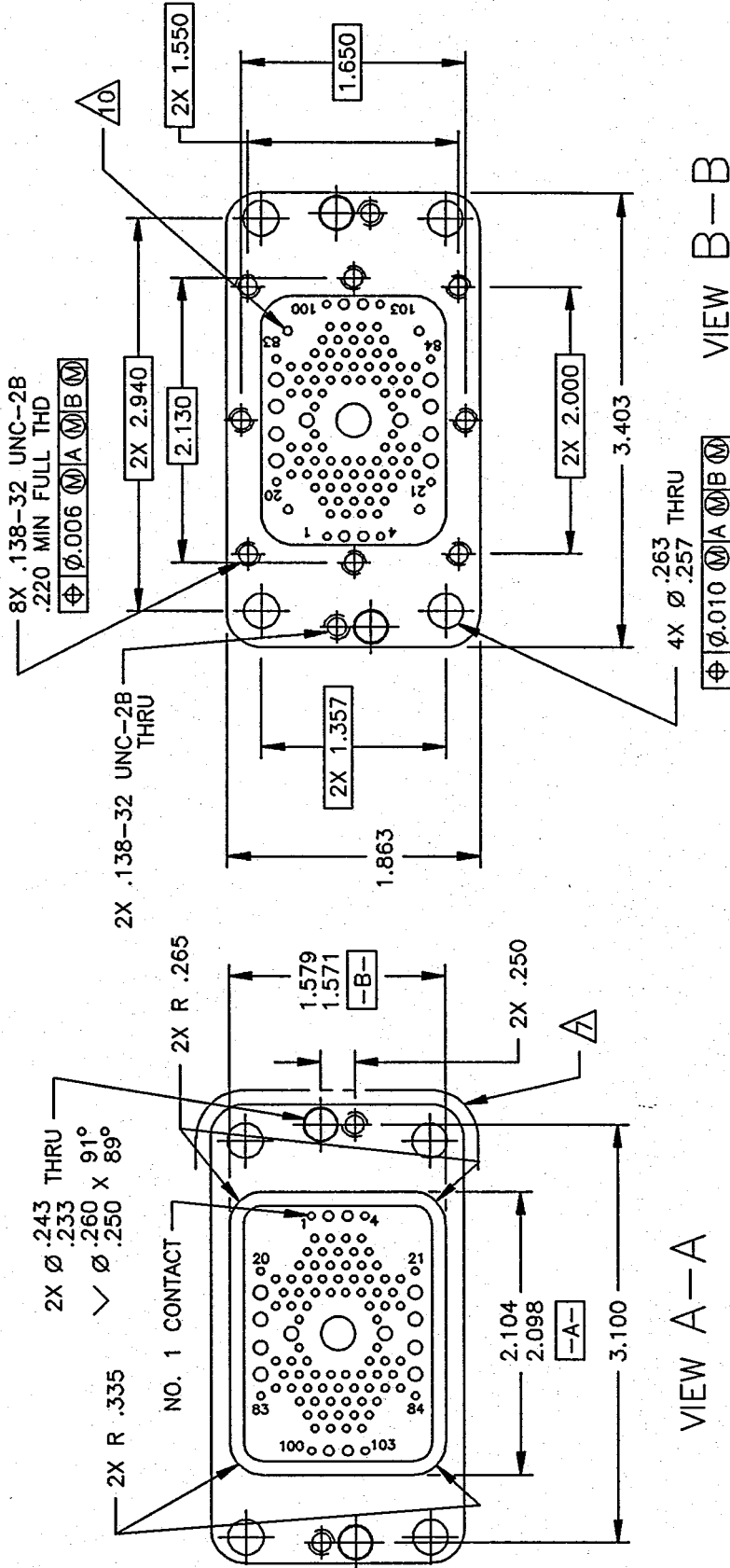

-1 CONTACT ARRANGEMENT

9. TOLERANCES: .XX = ±.03
.XXX = ±.010

△ HOLES SHOWN ARE NON-FUNCTIONAL (4 PLACES).

11. PART MATES WITH RECEPTACLE GSFC-700-42/5-X-P.

12. FOR DRY LUBRICANT LOCATIONS, SEE FIGURE 2B (PAGE 3 OF 5).

△ FOR REFERENCE ONLY, NOT SPACE COMPATIBLE.
CANDIDATE REPLACEMENT CABLE TBD.

FIGURE 2B - CONNECTOR CONFIGURATION, PLUG, ELECTRICAL, RECTANGULAR (CONTD)
(PAGE 2 OF 5)

DRY LUBRICANT DEFINITION

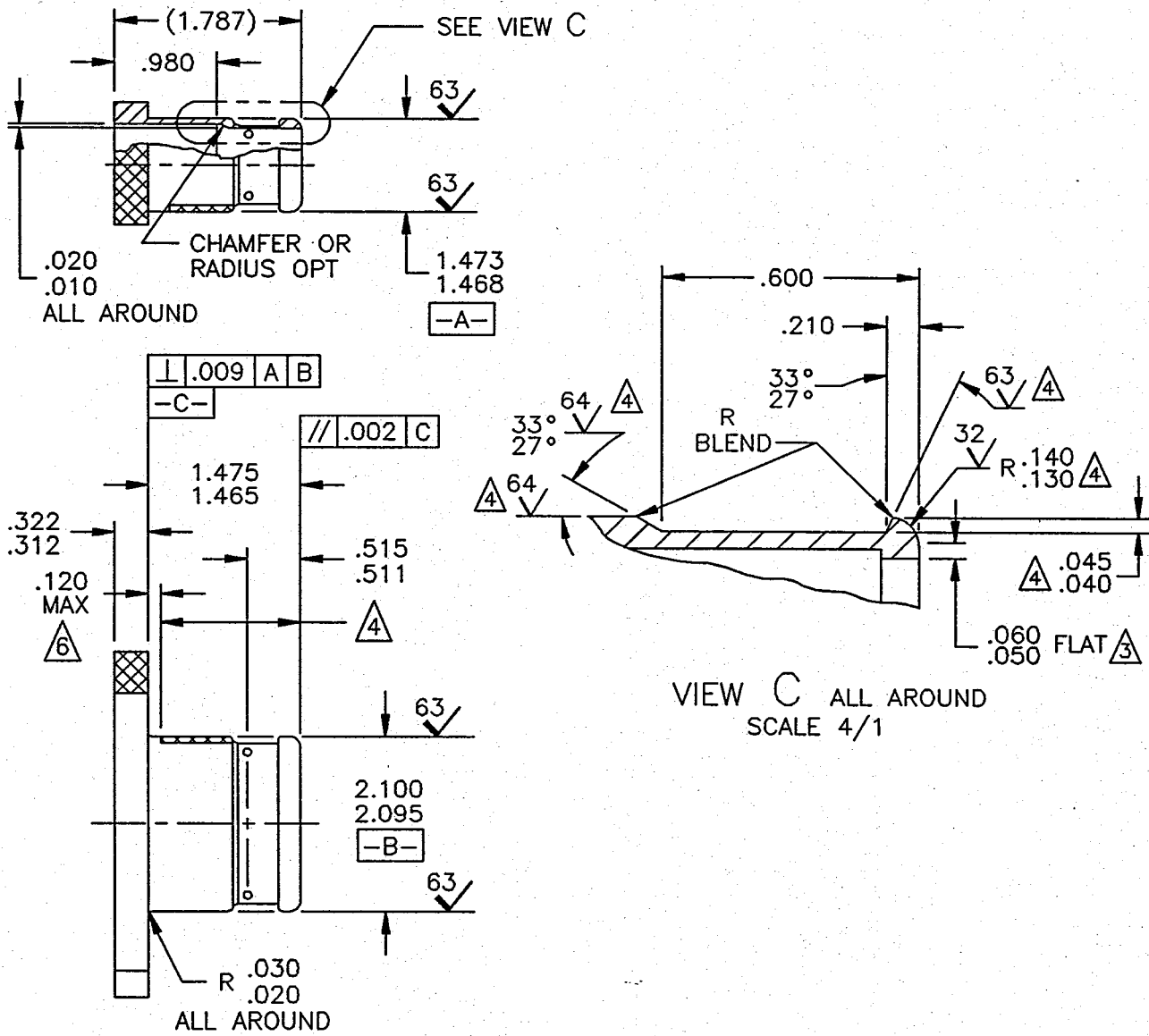

NOTES: UNLESS OTHERWISE SPECIFIED

1. INTERPRET PER DOD-STD-100.

② ELECTROLESS NICKEL PLATE PER MIL-C-26074, CLASS 4 EXCEPT THICKNESS TO BE .00176 - .0018 BUILDUP PER SURFACE.

③ NO SOLID FILM LUBRICANT PERMITTED ON SURFACES NOTED.

④ APPLY SOLID FILM LUBRICANT .0002-.0004 BUILDUP PER SURFACE PER G&H SPEC 999-143 TYPE I, CL 1, TO EXTERIOR SURFACE ALONG DIMENSION NOTED EXCEPT CURE 16 HOURS MINIMUM AT 250F - 260F.

FIGURE 2B - CONNECTOR CONFIGURATION, PLUG, ELECTRICAL, RECTANGULAR (CONTD)
(PAGE 3 OF 5)

MATED VIEW

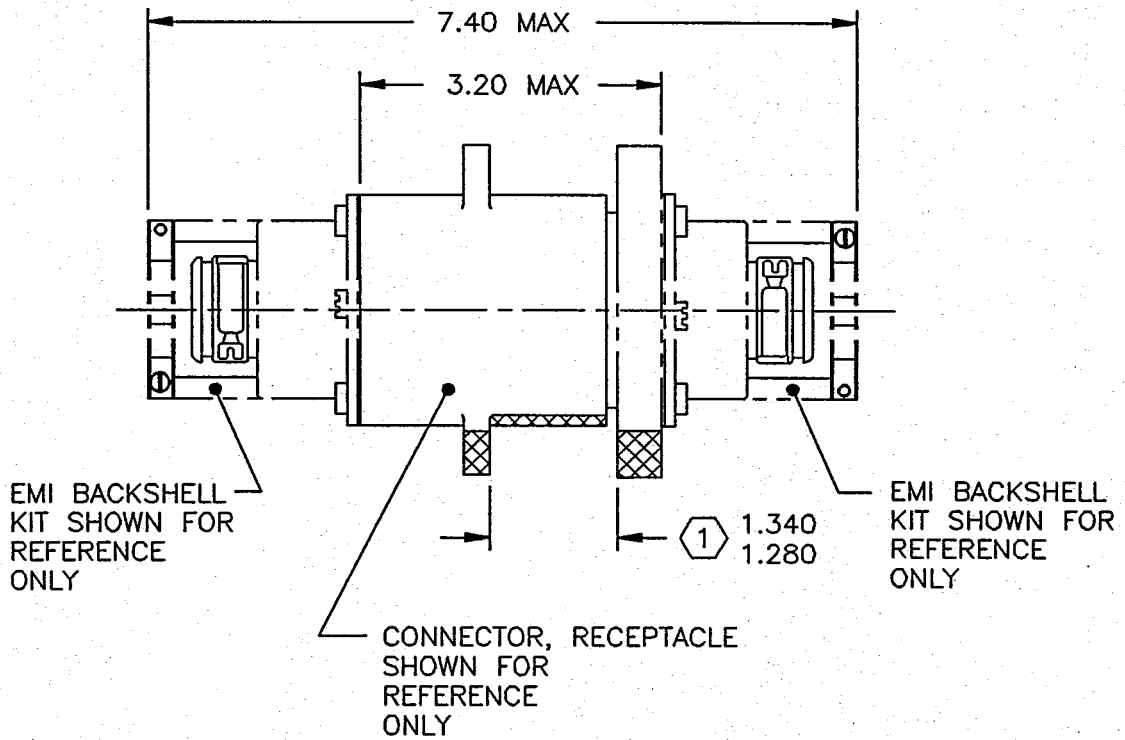

① CONNECTOR IS MATED WHEN DISTANCE NOTED BETWEEN FLANGES IS ACHIEVED

FIGURE 2B - CONNECTOR CONFIGURATION, PLUG, ELECTRICAL, RECTANGULAR (CONTD)
(PAGE 4 OF 5)

CONTACT SIZE	WIRE OR CABLE SIZE	CONTACT SOCKET PART NO.	COLOR CODE	SEALING PLUG PART NO.	CRIMP TOOL NO.	POSITIONER, LOCATOR OR DIE NO.	REMOVAL TOOL NO.	INSERTION TOOL NO.	PUSH TOOL NO.	CONNECTOR SEPARATING TOOL NO.	CONNECTOR MATING TOOL NO.
22	22-24-26	GPS25	BLUE/WHITE (2 BANDS)	MIL-C-81511/15-22	612118	615507	998-377-001	998-377-006	998-299-COTO		
20	20-22-24	GPS24	GREEN/WHITE (2 BANDS)	MS3187A20	M22520/1-01	M22520/1-02	998-377-002	998-377-005	998-300-COTO		
16	16-18-20	GPS22	BLUE/YELLOW (2 BANDS)	MS3187-16	M22520/1-01	M22520/1-02	998-377-002	998-377-003	882-91-001		882-60-001 (2 REQ'D)
	22-24-26	GPS23	BLUE/RED (2 BANDS)		M22520/7-01	M22520/7-04	998-377-002				
RG 142 B/U COAX	M17/060	(GCS28)	GREEN (1 BAND)		M22520/2-01 AND M22520/5-01	K709 AND K631			NOT REQUIRED		
TRIAX		GTS26	YELLOW (1 BAND)	MS27488-8			998-388-001	NOT REQUIRED	NOT REQUIRED		
DATABUS (TWINAX)		GDS27	BLACK (1 BAND)								
RG 122/U COAX	M17/54	GCP29	NONE	MS27488-4	M22520/5-01	M22520/5-05	998-142-001	NOT REQUIRED	NOT REQUIRED		
CONTACT PATTERN IDENTIFICATION NUMBER											
CONTACT SIZE											
GSFC 700-42/5-1-S	GSFC 700-42/5-2-S										
1, 4 THRU 30, 32 THRU 39, 41 THRU 46, 48, 49, 55, 56, 58 THRU 63, 65 THRU 72, 74 THRU 100, 103	NONE										
2, 3, 101, 102	1 THRU 8, 16 THRU 18, 20 THRU 34, 37 THRU 51, 53 THRU 55, 63 THRU 70										
31, 40, 47, 50, 51, 53, 54, 57, 64, 73	9 THRU 15, 19, 52, 56 THRU 62										
NONE	RG 142 B/U COAX										
	TRIAX										
	DATABUS (TWINAX)										
52	RG 122/U COAX										

FIGURE 2B - CONNECTOR CONFIGURATION, PLUG, ELECTRICAL, RECTANGULAR (CONTD)
(PAGE 5 OF 5)