

**MS9805**

FED SUP CLASS  
5306

MARK PART NUMBER AND  
MANUFACTURERS IDENTIFICATION  
PER AS 478 CLASS A

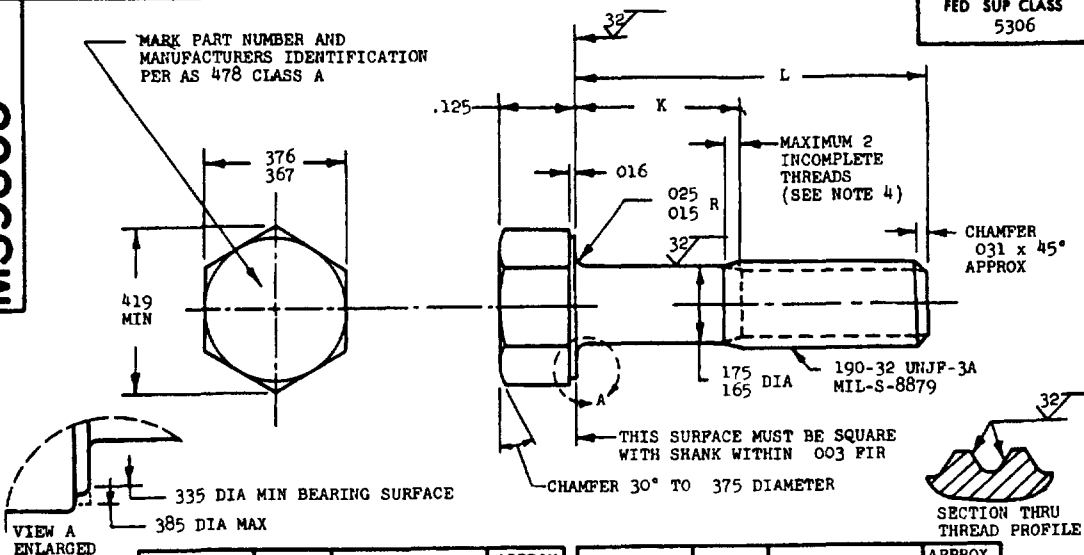

PART NUMBER	L	K	APPROX WEIGHT LB/100	PART NUMBER	L	K	APPROX WEIGHT LB/100
MS9805-03	312	072- 092	62	MS9805-31	2 125	1 435-1 495	1 78
MS9805-04	375	072- 092	66	MS9805-32	2 250	1 560-1 620	1 86
MS9805-05	438	072- 092	70	MS9805-33	2 375	1 685-1 745	1 94
MS9805-06	500	072- 092	74	MS9805-34	2 500	1 810-1 870	2 02
MS9805-07	562	072- 092	78	MS9805-35	2 625	1 935-1 995	2 10
MS9805-08	625	072- 092	82	MS9805-36	2 750	2 060-2 120	2 18
MS9805-09	688	072- 092	86	MS9805-37	2 875	2 185-2 245	2 26
MS9805-10	750	072- 120	90	MS9805-38	3 000	2 310-2 370	2 34
MS9805-11	812	122- 182	94	MS9805-39	3 125	2 435-2 495	2 42
MS9805-12	875	185- 245	98	MS9805-40	3 250	2 560-2 620	2 50
MS9805-13	938	248- 308	1 02	MS9805-41	3 375	2 685-2 745	2 58
MS9805-14	1 000	310- 370	1 07	MS9805-42	3 500	2 810-2 870	2 66
MS9805-15	1 062	372- 432	1 11	MS9805-43	3 625	2 935-2 995	2 74
MS9805-16	1 125	435- 495	1 15	MS9805-44	3 750	3 060-3 120	2 82
MS9805-17	1 188	498- 558	1 19	MS9805-45	3 875	3 185-3 245	2 90
MS9805-18	1 250	560- 620	1 23				
MS9805-19	1 312	622- 682	1 27				
MS9805-20	1 375	685- 745	1 30				
MS9805-21	1 438	748- 808	1 34				
MS9805-22	1 500	810- 870	1 38				
MS9805-23	1 562	872- 932	1 42				
MS9805-24	1 625	935- 995	1 46				
MS9805-25	1 688	998-1 058	1 50				
MS9805-26	1 750	1 060-1 120	1 54				
MS9805-27	1 812	1 122-1 182	1 58				
MS9805-28	1 875	1 185-1 245	1 62				
MS9805-29	1 938	1 248-1 308	1 66				
MS9805-30	2 000	1 310-1 370	1 70				

- SHANK SHALL BE STRAIGHT WITHIN .003 TOTAL PER INCH OF BOLT LENGTH
- THE CONCENTRICITY OF THREAD PD IN RELATION TO THE SHANK SHALL BE WITHIN .006 FIR
- THE CONCENTRICITY OF THE SHANK IN RELATION TO THE WASHER FACE DIAMETER AND HEXAGON SHALL BE WITHIN .011 FIR
- INCOMPLETE THREADS NOT TO ENTER FILLET
- MATERIAL CORROSION RESISTANT STEEL AMS 5643
- HARDNESS ROCKWELL C32-38
- MANUFACTURING SPECIFICATION AMS 7474
- FLUORESCENT PENETRANT INSPECTION PER AMS 2645
- SURFACE TEXTURE USAS B46 1-1962 UNLESS OTHERWISE SPECIFIED, SURFACES TO BE 125 MICROINCHES EXCEPT UPSET HEAD
- BREAK SHARP EDGES .003- .015 UNLESS OTHERWISE SPECIFIED
- DIMENSIONS IN INCHES UNLESS OTHERWISE SPECIFIED, TOLERANCES LINEAR DIMENSIONS ± .010, ANGULAR DIMENSIONS ±5°
- DO NOT USE UNASSIGNED PART NUMBERS

AS & AMS ARE SOCIETY OF AUTOMOTIVE ENGINEERS, INC PUBLICATIONS  
THIS STANDARD WAS DEVELOPED COOPERATIVELY WITH THE MILITARY SERVICES BY THE SAE AEROSPACE PART STANDARDS DIV.

P.A. USAF-II	INTERNATIONAL INTEREST	TITLE	MILITARY STANDARD
Other Cust ARMY-AV NAVY-AS	ASCG AIR STD 17/2	BOLT, MACHINE - HEXAGON HEAD, PD SHANK, AMS 5643, 190-32 UNJF-3A	<b>MS9805</b>
PROCUREMENT SPECIFICATION NONE	SUPERSEDES:		SHEET 1 OF 1

This military standard is approved by the Department of Defense and is mandatory on all activities. Substitutions for all new engineering and design applications and for repetitive use shall be made from this document.

APPROVED 11 MAR 70 REVISED