

FED SUP CLASS
5305

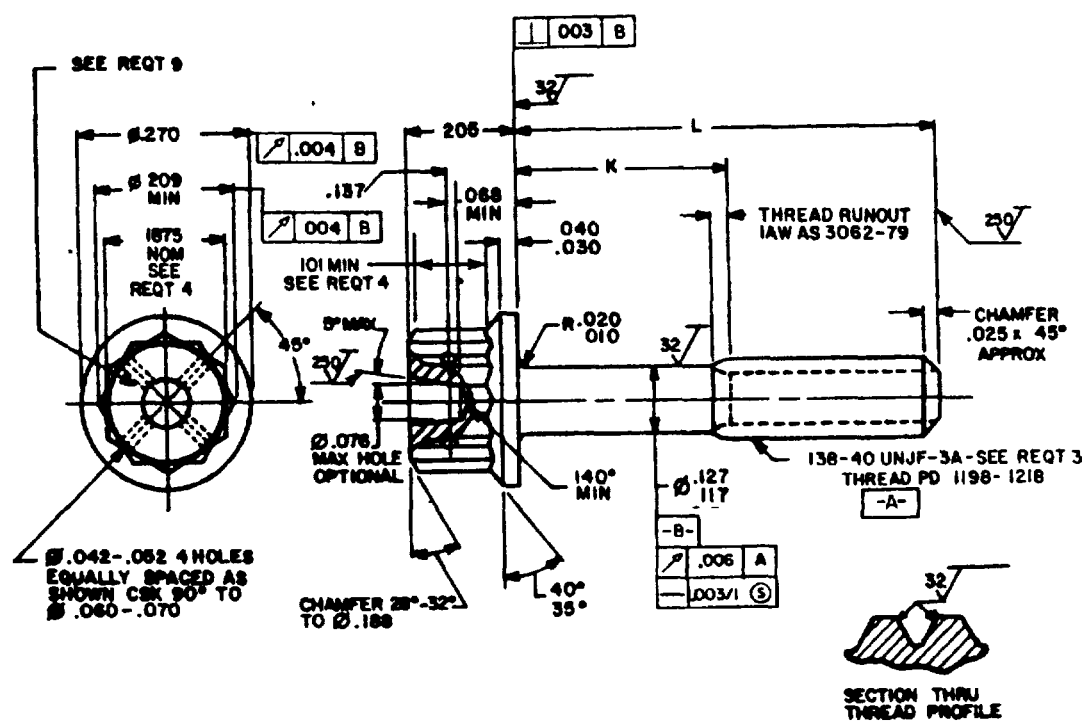

TABLE I. DASH NUMBERS AND DIMENSIONS.

DASH NUMBER	L	K	APPROX WEIGHT LB/100	DASH NUMBER	L	K	APPROX WEIGHT LB/100
-02	.250	.058-.078	.29	-14	1.000	.414-.474	.55
-03	.312	.058-.078	.31	-15	1.062	.476-.536	.57
-04	.375	.058-.078	.33	-16	1.125	.539-.599	.59
-05	.438	.058-.078	.35	-17	1.188	.602-.662	.61
-06	.500	.058-.078	.37	-18	1.250	.664-.724	.63
-07	.562	.058-.078	.39	-19	1.312	.726-.786	.65
-08	.625	.058-.099	.42	-20	1.375	.789-.849	.66
-09	.688	.102-.162	.44	-21	1.438	.852-.912	.70
-10	.750	.164-.224	.46	-22	1.500	.914-.974	.72
-11	.812	.226-.286	.48				
-12	.875	.289-.349	.50				
-13	.938	.352-.412	.52				

(A) ENTIRE STANDARD REVISED

USER ACTIVITIES

 REVIEWER ACTIVITIES
 AIR FORCE - 82
 DLA-1S

DISTRIBUTION STATEMENT A Approved for public release; distribution is unlimited
 This military standard is approved for use by all Departments and Agencies of the Department of Defense.
 Selection for all new engineering and design applications and for repetitive use shall be made from this document when applicable.

U.S. NAVY AS Other Code ARMY-AV AIR FORCE-99	INTERNATIONAL INTEREST	TITLE SCREW, MACHINE-DOUBLE HEXAGON, EXTENDED WASHER HEAD, DRILLED, SILVER PLATED, CORROSION AND HEAT RESISTANT STEEL, .138-40 UNJF-3A	MILITARY STANDARD	
			MS9712	
PROCUREMENT SPECIFICATION AMS 7471	SUPERSEDES	PAGE 1 OF 2		

AMSC N/A

DD FORM 672-1 (COORDINATED)

PREVIOUS EDITIONS OF THIS FORM ARE OBSOLETE

5305-1596
E25-187-3

APPROVED 3 MAR 69
 REVISED 24 FEB 86

FED SUP CLASS
5305

REQUIREMENTS:

1. **MATERIAL:** CORROSION AND HEAT RESISTANT STEEL IN ACCORDANCE WITH AMS 5708.
2. **FILLET:** SILVER PLATE IN ACCORDANCE WITH AMS 2410, .0002-.0006 THICK AT THREAD PD. DIMENSIONS SPECIFIED ARE AFTER PLATING.
3. **THREADS:** THREADS IN ACCORDANCE WITH MIL-S-8879. INCOMPLETE THREADS NOT TO ENTER FILLET.
4. **WRENCHING CONFIGURATION:** WRENCHING CONFIGURATION IN ACCORDANCE WITH AS 870.
5. **DIMENSIONING AND TOLERANCING:** DIMENSIONING AND TOLERANCING SHALL BE IN ACCORDANCE WITH ANSI Y14.5M.
6. **SURFACE TEXTURE:** SURFACE TEXTURE, UNLESS OTHERWISE SPECIFIED, SHALL BE 125 MICRONS EXCEPT UPSET END IN ACCORDANCE WITH ANSI B46.1.
7. **FLUORESCENT PENETRANT INSPECTION:** FLUORESCENT PENETRANT INSPECTION SHALL BE IN ACCORDANCE WITH AMS 2645-83, BEFORE PLATING.
8. **HEAD TO SHANK FILLET:** HEAD TO SHANK FILLET SHALL BE COLD ROLLED AFTER HEAT TREATMENT TO REMOVE ALL VISUAL EVIDENCE OF GRINDING OR TOOL MARKS EXCEPT DASH NUMBER SIZES -10 AND SMALLER.
9. **MARKING:** MARK PART NUMBER AND MANUFACTURER'S IDENTIFICATION IN ACCORDANCE WITH AS 478-79, CLASS A.
10. **TOLERANCES:** UNLESS OTHERWISE SPECIFIED, TOLERANCES SHALL BE FOR LINEAR DIMENSIONS $\pm .010$, ANGULAR DIMENSIONS $\pm 5^\circ$.
11. **EDGES:** BREAK SHARP EDGES .003-.015 UNLESS OTHERWISE SPECIFIED.
12. **PART NUMBER:** THE PART NUMBER SHALL CONSIST OF THE BASIC MS NUMBER FOLLOWED BY A DASH NUMBER FROM TABLE I.

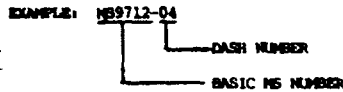

MS9712-04 INDICATES: SCREW, MACHINE - DOUBLE HEXAGON EXTENDED WASHER HEAD, DRILLED, SILVER PLATED .138-40 UNJF-3A, LENGTH .250

NOTES:

1. ALL DIMENSIONS ARE IN INCHES.
2. DO NOT USE UNASSIGNED PART NUMBERS.
3. IN THE EVENT OF A CONFLICT BETWEEN THE TEXT OF THIS STANDARD AND THE REFERENCES CITED HEREIN, THE TEXT OF THIS STANDARD SHALL TAKE PRECEDENCE.
4. REFERENCED GOVERNMENT (OR NONGOVERNMENT) DOCUMENTS OF THE ISSUE LISTED IN THAT ISSUE OF THE DEPARTMENT OF DEFENSE INDEX OF SPECIFICATIONS AND STANDARDS (DODISS) SPECIFIED IN THE SOLICITATION FORM A PART OF THIS STANDARD TO THE EXTENT SPECIFIED HEREIN.
5. THIS STANDARD WAS DEVELOPED COOPERATIVELY WITH THE SAE AEROSPACE PROPULSION DIVISION.
6. AS AND AMS ARE SAE PUBLICATIONS.

USER ACTIVITIES:

REVISOR ACTIVITIES:
AIR FORCE-82
DLA-18

This military standard is approved for use by all Departments and Agencies of the Department of Defense in accordance with instructions and change applications and for applications and shall be made from this document when appropriate.

APPROVED 3 MAR 69 REVISION (A) FOR CHANGES SEE PAGE 1 AND 2

U.S. NAVY-AS Other Code ARMY-4V AIR FORCE-99	INTERNATIONAL INTEREST	TITLE SCREW, MACHINE-DOUBLE HEXAGON, EXTENDED WASHER HEAD, DRILLED, SILVER PLATED, CORROSION AND HEAT RESISTANT STEEL, 138-40 UNJF-3A	MILITARY STANDARD
			MS9712
PROCUREMENT SPECIFICATION AMS 7471	SUPERSEDED	PAGE 2 OF 2	