

USER ACTIVITIES:

REVIEWER ACTIVITIES:
AIR FORCE-82
DLA-IS

DISTRIBUTION STATEMENT A. Approved for public release; distribution is unlimited.
This military standard is approved for use by all Departments and Agencies of the Department of Defense.
Selection for all engineering and design applications and for repetitive use shall be made from this document when applicable.

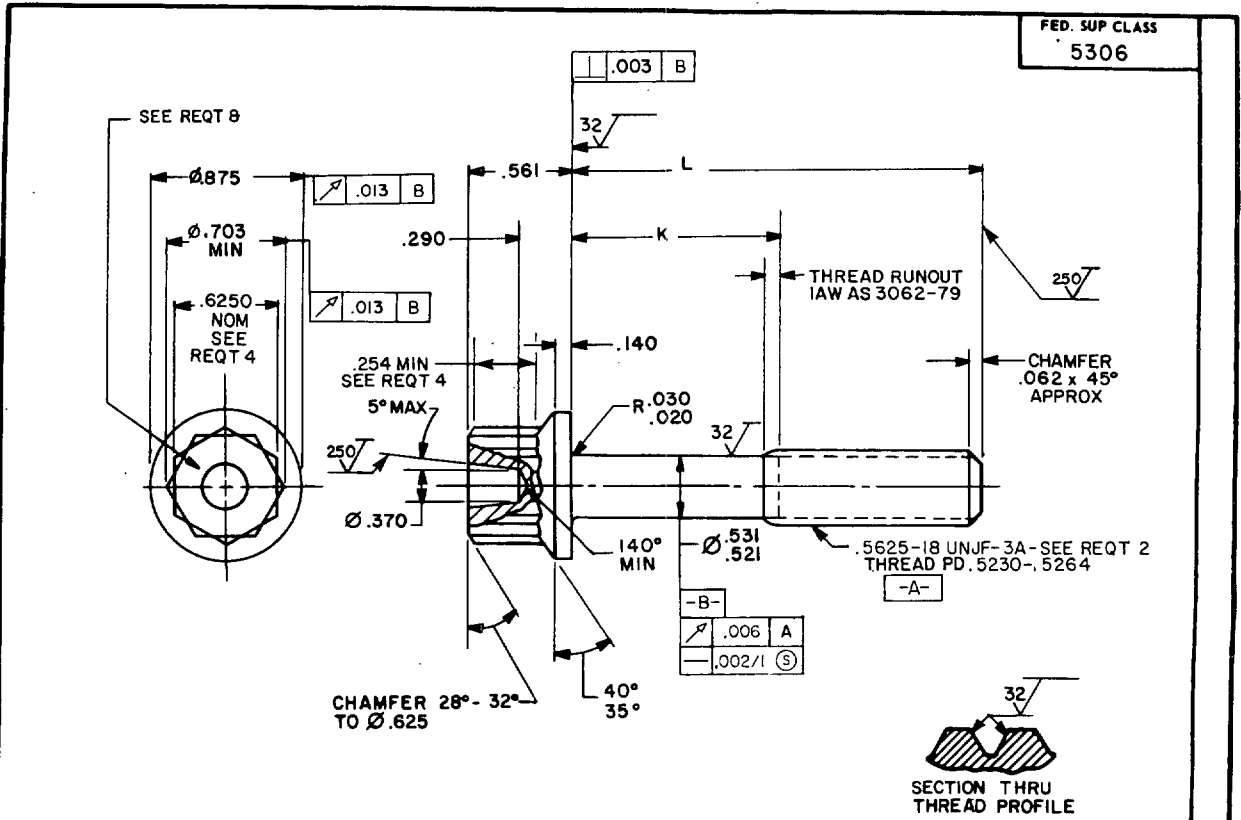

TABLE I. DASH NUMBERS AND DIMENSIONS

DASH NUMBER	L	K	APPROX WEIGHT LB/100
-04	.875	.113-.133	11.27
-05	.938	.113-.133	11.68
-06	1.000	.113-.133	12.08
-07	1.062	.113-.133	12.48
-08	1.125	.113-.133	12.88
-09	1.188	.113-.133	13.29
-10	1.250	.113-.133	13.69
-11	1.312	.113-.133	14.09
-12	1.375	.113-.133	14.49
-13	1.438	.113-.133	14.90
-14	1.500	.113-.133	15.30
-15	1.562	.128-.188	15.69
-16	1.625	.190-.250	16.10
-17	1.688	.252-.312	16.50
-18	1.750	.315-.375	16.90
-19	1.812	.378-.438	17.30
-20	1.875	.440-.500	17.71
-21	2.000	.565-.625	18.51

DASH NUMBER	L	K	APPROX WEIGHT LB/100
-22	2.125	.690-.750	19.32
-23	2.250	.815-.875	20.12
-24	2.375	.940-1.000	20.92
-25	2.500	1.065-1.125	21.73
-26	2.625	1.190-1.250	22.53
-27	2.750	1.315-1.375	23.34
-28	2.875	1.440-1.500	24.14
-29	3.000	1.565-1.625	24.94
-30	3.125	1.690-1.750	25.75
-31	3.250	1.815-1.875	26.55
-32	3.375	1.940-2.000	27.36
-33	3.500	2.065-2.125	28.16
-34	3.625	2.190-2.250	28.96
-35	3.750	2.315-2.375	29.77
-36	3.875	2.440-2.500	30.57
-37	4.000	2.565-2.625	31.38
-38	4.125	2.690-2.750	32.18
-39	4.250	2.815-2.875	32.98

DASH NUMBER	L	K	APPROX WEIGHT LB/100
-40	4.375	2.940-3.000	33.79
-41	4.500	3.065-3.125	34.59
-42	4.625	3.190-3.250	35.40
-43	4.750	3.315-3.375	36.20
-44	4.875	3.440-3.500	37.00
-45	5.000	3.565-3.625	37.81
-46	5.125	3.690-3.750	38.61
-47	5.250	3.815-3.875	39.42
-48	5.375	3.940-4.000	40.22
-49	5.500	4.065-4.125	41.03
-50	5.625	4.190-4.250	41.83
-51	5.750	4.315-4.375	42.63
-52	5.875	4.440-4.500	43.44
-53	6.000	4.565-4.625	44.24

(A) ENTIRE STANDARD REVISED

P. A. NAVY-AS Other Cust ARMY-AV AIR FORCE-99	INTERNATIONAL INTEREST	TITLE BOLT, MACHINE-DOUBLE HEXAGON, EXTENDED WASHER HEAD, CORROSION AND HEAT RESISTANT STEEL, .5625-18 UNJF-3A	MILITARY STANDARD MS9702
PROCUREMENT SPECIFICATION AMS 747I	SUPERSEDES:		PAGE 1 OF 2

REQUIREMENTS:

1. MATERIAL: CORROSION AND HEAT RESISTANT STEEL IN ACCORDANCE WITH AMS 5708.
2. THREADS: THREADS IN ACCORDANCE WITH MIL-S-8879. INCOMPLETE THREADS NOT TO ENTER FILLET.
3. DIMENSIONING AND TOLERANCING: DIMENSIONING AND TOLERANCING SHALL BE IN ACCORDANCE WITH ANSI Y14.5M.
4. WRENCHING CONFIGURATION: WRENCHING CONFIGURATION IN ACCORDANCE WITH AS 870.
5. SURFACE TEXTURE: SURFACE TEXTURE, UNLESS OTHERWISE SPECIFIED, SHALL BE 125 MICROINCHES EXCEPT UPSET HEAD IN ACCORDANCE WITH ANSI B46.1.
6. FLOUORESCENT PENETRANT INSPECTION: FLOUORESCENT PENETRANT INSPECTION SHALL BE IN ACCORDANCE WITH AMS 2645-83.
7. HEAD TO SHANK FILLET: HEAD TO SHANK FILLET SHALL BE COLD ROLLED AFTER HEAT TREATMENT TO REMOVE ALL VISUAL EVIDENCE OF GRINDING OR TOOL MARKS EXCEPT DASH NUMBER SIZES -16 AND SMALLER.
8. MARKING: MARK PART NUMBER AND MANUFACTURER'S IDENTIFICATION IN ACCORDANCE WITH AS 478-79, CLASS A.
9. TOLERANCE: UNLESS OTHERWISE SPECIFIED, TOLERANCES SHALL BE FOR LINEAR DIMENSIONS $\pm .010$, ANGULAR DIMENSIONS $\pm 5^\circ$.
10. EDGES: BREAK SHARP EDGES .003-.015 UNLESS OTHERWISE SPECIFIED.
11. PART NUMBER: THE PART NUMBER SHALL CONSIST OF THE BASIC MS NUMBER FOLLOWED BY A DASH NUMBER FROM TABLE I.

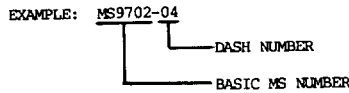

MS9702-04 INDICATES: BOLT, MACHINE - DOUBLE HEXAGON EXTENDED WASHER HEAD, .5625-18 UNJF-3A, LENGTH .875

NOTES:

1. ALL DIMENSIONS ARE IN INCHES.
2. DO NOT USE UNASSIGNED PART NUMBERS.
3. IN THE EVENT OF A CONFLICT BETWEEN THE TEXT OF THIS STANDARD AND THE REFERENCES CITED HEREIN, THE TEXT OF THIS STANDARD SHALL TAKE PRECEDENCE.
4. REFERENCED GOVERNMENT (OR NONGOVERNMENT) DOCUMENTS OF THE ISSUE LISTED IN THAT ISSUE OF THE DEPARTMENT OF DEFENSE INDEX OF SPECIFICATIONS AND STANDARDS (DODISS) SPECIFIED IN THE SOLICITATION FORM A PART OF THIS STANDARD TO THE EXTENT SPECIFIED HEREIN.
5. THIS STANDARD WAS DEVELOPED COOPERATIVELY WITH THE SAE AEROSPACE PROPULSION DIVISION.
6. AS AND AMS ARE SAE PUBLICATIONS.

USER ACTIVITIES:

REVIEWER ACTIVITIES:
AIR FORCE - 82
DLA-1S

This military standard is approved for use by all Departments and Agencies of the Department of Defense. Selection for all new engineering and design applications and for repetitive use shall be made from this document when applicable.

APPROVED 3 MAR 69 REVISED (A) FOR CHANGES SEE PAGE 1 AND 2

P. A. NAVY-AS Other Cust ARMY-AV AIR FORCE-99 PROCUREMENT SPECIFICATION AMS 7471	INTERNATIONAL INTEREST	TITLE BOLT, MACHINE-DOUBLE HEXAGON, EXTENDED WASHER HEAD, CORROSION AND HEAT RESISTANT STEEL, 5625-18 UNJF-3A	MILITARY STANDARD
			MS9702
SUPERSEDES:		PAGE 2 OF 2	