

THE REQUIREMENTS FOR ACQUIRING THE PRODUCT(S) DESCRIBED HEREIN SHALL CONSIST OF THIS SPECIFICATION SHEET AND THE ISSUE OF THE FOLLOWING SPECIFICATION LISTED IN THAT ISSUE OF THE DOCUMENT SPECIFIED IN THE SOLICITATION NONE

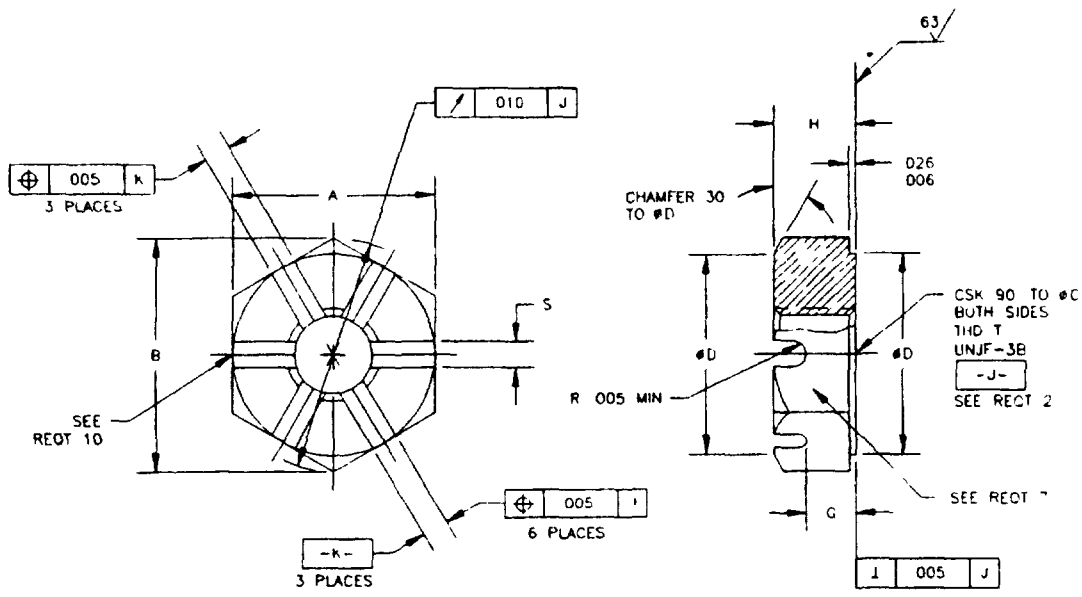

TABLE 1 DASH NUMBERS AND DIMENSIONS

DASH NUMBER	THREAD T	A	B MIN	#C	#D	G	H	S	APPROX MASS LB/100
-08	164-36	336-345	383	164-184	334-354	068-088	146-166	073-088	0.35
-09	190-32	367-376	419	190-210	365-385	084-104	178-198	073-088	0.37
-10	250-28	430-439	491	250-270	428-448	084-104	178-198	073-088	0.51
-11	3125-24	492-502	561	312-332	490-510	084-104	178-198	073-088	0.64
-12	375-24	553-564	631	375-395	552-572	099-119	209-229	115-135	0.79
-13	4375-20	679-690	775	438-458	678-698	099-119	209-229	115-135	1.59
-14	500-20	741-752	846	500-520	740-760	131-151	240-260	115-135	1.95
-15	5625-18	865-877	987	562-582	865-885	178-198	302-322	146-166	3.45
-16	625-18	928-940	1059	625-645	928-948	178-198	302-322	146-166	3.85
-17	750-16	1052-1064	1200	750-770	1052-1072	240-260	365-385	146-166	5.71
-18	875-14	1239-1252	1414	875-895	1240-1260	302-322	428-448	146-166	9.57
-19	1000-12	1427-1440	1628	1000-1020	1428-1448	365-365	490-510	146-166	14.84

© DENOTES CHANGE(S)

INCH-POUND

PREPARING ACTIVITY DLA-15 CUSTODIAN'S ARMY- AV NAVY AL AIR FORCE- 11 REVIEW AT ER 82 B5 USER PROJECT NUMBER 5310-2011 DISTRIBUTION STATEMENT	MILITARY SPECIFICATION SHEET TITLE NUT SLOTTED HEXAGON-SHEAR A-286	SPECIFICATION SHEET NUMBER MS9363 26 OCT 94 REV C SUPERSEDING MS9363 B 30 SEP 86 AMSC- N/A FSC 5310
A Approved for public release distribution is unlimited		Page 1 of 2

THIS SPECIFICATION IS APPROVED FOR USE BY ALL DEPARTMENTS AND AGENCIES OF THE DEPARTMENT OF DEFENSE

THE REQUIREMENTS FOR ACQUIRING THE PRODUCT(S) DESCRIBED HEREIN SHALL CONSIST OF THIS SPECIFICATION SHEET AND THE ISSUE OF THE FOLLOWING SPECIFICATION LISTED IN THE ISSUE OF THE DOCUMENT SPECIFIED IN THE SOLICITATION NONE

THIS SPECIFICATION IS APPROVED FOR USE BY ALL DEPARTMENTS AND AGENCIES OF THE DEPARTMENT OF DEFENSE

Form Approved  
OMB No. 0704-0188

REQUIREMENTS

- (E) 1. MATERIAL CORROSION AND HEAT RESISTANT STEEL IN ACCORDANCE WITH AMS 5715 OR AMS 5737
- 2. THREAD THREADS IN ACCORDANCE WITH MIL-S-8879
- 3. CLEANING FINISHED PARTS SHALL BE DEGREASED AND IMPRESSED FOR NOT LESS THAN 20 MINUTES IN A SOLUTION OF 1 VOLUME OF NITRIC ACID (SP GR 1.42) AND 9 VOLUMES OF WATER AT ROOM TEMPERATURE
- (C) 4. SURFACE TEXTURE SURFACE TEXTURE UNLESS OTHERWISE SPECIFIED SHALL BE 125 MICROINCHES EXCEPT FOR HEX FACES IN ACCORDANCE WITH ANSI/ASME B46.1
- (C) 5. FLUORESCENT PENETRANT INSPECTION FLUORESCENT PENETRANT INSPECTION SHALL BE IN ACCORDANCE WITH AMS 2641 AND AS3071
- 6. DIMENSIONING AND TOLERANCING DIMENSIONING AND TOLERANCING SHALL BE IN ACCORDANCE WITH ANSI Y14.5M
- 7. MARKING MARK PART NUMBER AND MANUFACTURER'S IDENTIFICATION IN ACCORDANCE WITH AS47E-79 CLASS C. MULTIPLE MARKING OF BAF STOCK IS PERMISSIBLE PROVIDED POSITIVE IDENTIFICATION IS SHOWN. PARTS SHALL BE MARKED BEFORE THREADING. DASH NUMBERS MAY APPEAR ON ADJACENT FLATS
- 8. EDGES BREAK SHARP EDGES 003-015 UNLESS OTHERWISE SPECIFIED
- 9. TOLERANCES UNLESS OTHERWISE SPECIFIED TOLERANCES FOR ANGULAR DIMENSIONS  $\pm 5$  LINEAR DIMENSIONS  $\pm 0.10$
- 10. OPPOSITE SLOTS OPPOSITE SLOTS SHALL COINCIDE WITHIN .005 AND SLOT AXIS SHALL BE WITHIN .005 OF THREAD PD AXIS
- 11. PART NUMBER THE PART NUMBER SHALL CONSIST OF THE BASIC MS NUMBER FOLLOWED BY A DASH NUMBER FROM TABLE 1

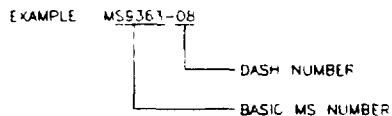

MS9363-08 INDICATES - NUT SLOTTED HEXAGON SHEAR A-286 164-36 UNJF-3P

NOTES

- 1. ALL DIMENSIONS ARE IN INCHES
- 2. DO NOT USE UNASSIGNED PART NUMBERS
- (C) 3. IN THE EVENT OF A CONFLICT BETWEEN THE TEXT OF THIS DOCUMENT AND THE REFERENCES CITED HEREIN, THE TEXT OF THIS DOCUMENT SHALL TAKE PRECEDENCE
- (C) 4. UNLESS OTHERWISE SPECIFIED ISSUES OF REFERENCED DOCUMENTS ARE THOSE IN EFFECT AT THE TIME OF SOLICITATION
- 5. THIS STANDARD WAS DEVELOPED COOPERATIVELY WITH THE SAE AEROSPACE PROPULSION DIVISION
- 6. AS AND AMS ARE SAE PUBLICATIONS
- 7. CERTAIN PROVISIONS (LIMITS OF SIZE ACROSS-FLATS DIMENSIONS) OF THIS STANDARD ARE THE SUBJECT OF INTERNATIONAL STANDARDIZATION AGREEMENT ASCC AID STD 17/2. WHEN REVISION OR CANCELLATION OF THIS STANDARD IS PROPOSED THE DEPARTMENTAL CUSTODIAN WILL INFORM THE RESPECTIVE DEPARTMENTAL STANDARDIZATION OFFICE SO THAT APPROPRIATE ACTION MAY BE TAKEN RESPECTING THE INTERNATIONAL AGREEMENT CONCERNED

(C) DENOTES CHANGE(S)

INCH-POUND

PREPARING ACTIVITY DLA IS CUSTODIANS ARMY - AV NAVY - AS AIR FORCE - 11 REVIEW AT ER 82 B5 USER PROJECT NUMBER 5310 1011	MILITARY SPECIFICATION SHEET TITLE NUT SLOTTED HEXAGON-SHEAR A-286	SPECIFICATION SHEET NUMBER MS9363 26 OCT 94 REV C
		SUPERSEDING MS9363 B 30 SEP 86 AMSC - N/A FSC 5310
DISTRIBUTION STATEMENT A. Approved for public release; distribution is unlimited.		Page 2 of 2