

THE REQUIREMENTS FOR ACQUIRING THE PRODUCT(S) DESCRIBED HEREIN SHALL CONSIST OF THIS SPECIFICATION SHEET AND THE ISSUE OF THE FOLLOWING SPECIFICATION LISTED IN THAT ISSUE OF THE DODISS SPECIFIED IN THE SOLICITATION NONE

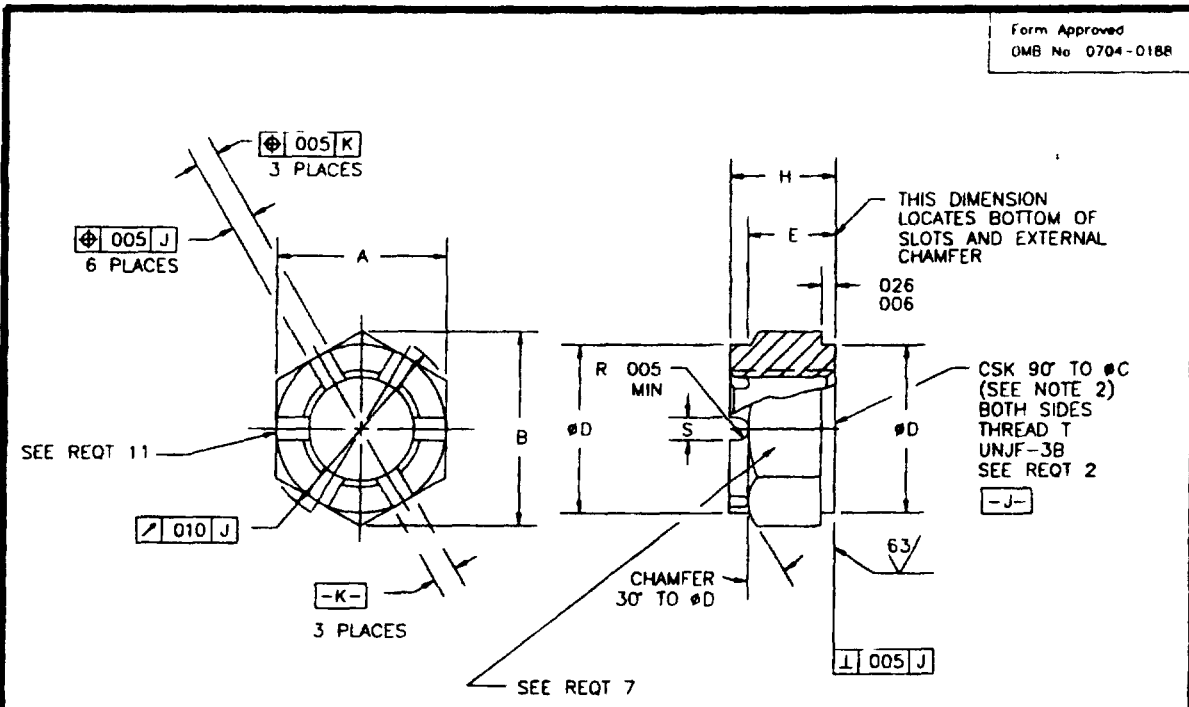

TABLE I DASH NUMBERS AND DIMENSIONS

DASH NO	THREAD T	A	B MIN	#C	#D	E	H	S	APPROX. MASS LB/100
-08	164-36	336 - 345	383	164 - 184	334 - 354	115 - 135	209 - 229	073 - 088	52
-09	190-32	367 - 376	419	190 - 210	365 - 385	146 - 166	240 - 260	073 - 088	56
-10	250-28	430 - 439	491	250 - 270	428 - 448	178 - 198	272 - 292	073 - 088	84
-11	3125-24	492 - 502	561	312 - 332	490 - 510	224 - 244	318 - 338	073 - 088	1 25
-12	375-24	553 - 564	631	375 - 395	552 - 572	271 - 291	396 - 416	115 - 135	1 73
-13	4375-20	679 - 690	775	438 - 458	678 - 698	318 - 339	444 - 464	115 - 135	3 12
-14	500-20	741 - 752	846	500 - 520	740 - 760	365 - 385	552 - 572	115 - 135	4 32
-15	5625-18	865 - 877	987	562 - 582	865 - 885	412 - 432	600 - 620	146 - 166	7 36
-16	625-18	928 - 940	1 059	625 - 645	928 - 948	458 - 478	708 - 728	146 - 166	8 50
-17	750-16	052 - 1 064	1 200	750 - 770	1 052 - 1 072	552 - 572	802 - 822	146 - 166	11 80
-18	875-14	1 239 - 1 252	1 414	875 - 895	1 240 - 1 260	646 - 666	896 - 916	146 - 166	18 99
-19	1 000-12	1 427 - 1 440	1 628	1 000 - 1 020	1 428 - 1 448	740 - 760	990 - 1 010	146 - 166	28 57

THIS SPECIFICATION IS APPROVED FOR USE BY ALL DEPARTMENTS AND AGENCIES OF THE DEPARTMENT OF DEFENSE.

(C) DENOTES CHANGE(S)

INCH-POUND

PREPARING ACTIVITY DLA-IS CUSTODIANS ARMY- AV NAVY- AS AIR FORCE- 11 DLA- REVIEW AR, ER, MI, 82, 85 USER PROJECT NUMBER 5310-2005 DISTRIBUTION STATEMENT	MILITARY SPECIFICATION SHEET TITLE NUT, CASTELLATED, HEXAGON-A-286	SPECIFICATION SHEET NUMBER MS9358 30 SEP 1994 REV C SUPERSEDING MS9358 B 30 SEP 86 (SEE NOTE 3) AMSC- N/A FSC 5310
A. Approved for public release, distribution is unlimited		Page 1 of 2

THE REQUIREMENTS FOR ACQUIRING THE PRODUCT(S) DESCRIBED HEREIN SHALL CONSIST OF THIS SPECIFICATION SHEET AND THE ISSUE OF THE FOLLOWING SPECIFICATION LISTED IN THAT ISSUE OF THE DODISS SPECIFIED IN THE SOLICITATION NONE

THIS SPECIFICATION IS APPROVED FOR USE BY ALL DEPARTMENTS AND AGENCIES OF THE DEPARTMENT OF DEFENSE

Form Approved  
OMB No 0704-0188

REQUIREMENTS

- (C) 1. MATERIAL CORROSION AND HEAT RESISTANT STEEL IN ACCORDANCE WITH AMS 5732 OR AMS 5737
- 2. THREADS THREADS IN ACCORDANCE WITH MIL-S-8879
- 3. CLEANING FINISHED PARTS SHALL BE DECREASED AND IMPRESSED FOR NOT LESS THAN 20 MINUTES IN A SOLUTION OF 1 VOLUME OF NITRIC ACID (SP GR 1.42) AND 9 VOLUMES OF WATER AT ROOM TEMPERATURE
- (C) 4. SURFACE TEXTURE SURFACE TEXTURE UNLESS OTHERWISE SPECIFIED SHALL BE 125 MICRONS EXCEPT FOR HEX FACES IN ACCORDANCE WITH ANSI/ASME B46.1
- 5. FLUORESCENT PENETRANT INSPECTION FLUORESCENT PENETRANT INSPECTION SHALL BE IN ACCORDANCE WITH AMS 2645 AND AS 3071
- 6. DIMENSIONING AND TOLERANCING DIMENSIONING AND TOLERANCING SHALL BE IN ACCORDANCE WITH ANSI Y14.5M
- 7. MARKING MARK PART NUMBER AND MANUFACTURER'S IDENTIFICATION IN ACCORDANCE WITH AS 478, CLASS C MULTIPLE MARKING OF BAR STOCK IS PERMISSIBLE PROVIDED POSITIVE IDENTIFICATION IS SHOWN PARTS SHALL BE MARKED BEFORE THREADING DASH NUMBERS MAY APPEAR ON ADJACENT FLATS
- 8. FOR SIZES 3/16-24 AND SMALLER COUNTERDRILL "C" FROM SLOTTED SIDE TO DEPTH OF SLOT
- 9. EDGES BREAK SHARP EDGES 003-015 UNLESS OTHERWISE SPECIFIED
- 10. TOLERANCES UNLESS OTHERWISE SPECIFIED TOLERANCES FOR ANGULAR DIMENSIONS ± 5 LINEAR DIMENSIONS ± 0.10
- 11. OPPOSITE SLOTS OPPOSITE SLOTS SHALL COINCIDE WITHIN 005 AND SLOT AXIS SHALL BE WITHIN 005 OF THREADED PD AXIS
- 12. PART NUMBER THE PART NUMBER SHALL CONSIST OF THE BASIC MS NUMBER FOLLOWED BY A DASH NUMBER FROM TABLE I

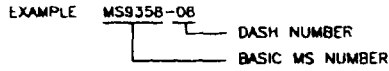

MS9358-08 INDICATES - NUT CASTELLATED HEXAGON A-286 164-36 UNJF-3B

NOTES

- 1. ALL DIMENSIONS ARE IN INCHES
- 2. DO NOT USE UNASSIGNED PART NUMBERS
- (C) 3. IN THE EVENT OF A CONFLICT BETWEEN THE TEXT OF THIS STANDARD AND THE REFERENCES CITED HEREIN THE TEXT OF THIS STANDARD SHALL TAKE PRECEDENCE.
- (C) 4. UNLESS OTHERWISE SPECIFIED, ISSUES OF REFERENCED DOCUMENTS ARE THOSE IN EFFECT AT THE TIME OF SOLICITATION
- (C) 5. THIS DOCUMENT WAS DEVELOPED COOPERATIVELY WITH THE SAE AEROSPACE PROPULSION DIVISION
- 6. AS AND AMS ARE SAE PUBLICATIONS
- (C) 7. CERTAIN PROVISIONS (LIMITS OF SIZE ACROSS-FLATS DIMENSIONS) OF THIS DOCUMENT ARE THE SUBJECT OF INTERNATIONAL STANDARDIZATION AGREEMENT ASCC AND STD 17/2 WHEN REVISION OR CANCELLATION OF THIS STANDARD IS PROPOSED THE DEPARTMENTAL CUSTODIAN WILL INFORM THEIR RESPECTIVE DEPARTMENTAL STANDARDIZATION OFFICE SO THAT APPROPRIATE ACTION MAY BE TAKEN RESPECTING THE INTERNATIONAL AGREEMENT CONCERNED
- (C) 8. MS9356 SUPERSEDES AN 121578 THRU AN 121600

PREPARING ACTIVITY DLA-15 CUSTODIANS ARMY- AV NAVY- AS AIR FORCE- 11 DLA- REVIEW AR, ER, MI, 82, 85 USER PROJECT NUMBER 5310-2005	MILITARY SPECIFICATION SHEET TITLE NUT, CASTELLATED, HEXAGON-A-286	SPECIFICATION SHEET NUMBER <b>MS9358</b> 30 SEP 1994 REV C
		SUPERSEDING MS9358 B 30 SEP 86 (SEE NOTE 8) AMSC- N/A FSC 5310
DISTRIBUTION STATEMENT A. Approved for public release, distribution is unlimited		Page 2 of 2