

17884

FED SUP CLASS
5310

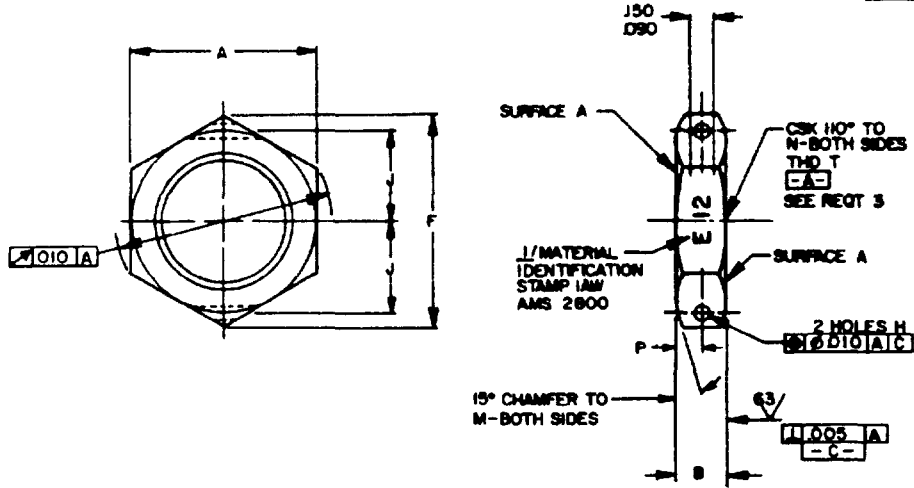

TABLE I DASH NUMBERS AND DIMENSIONS.

DASH NUMBER	NOM TUBE OD	THREAD T	A	B	F MIN	ØH ± .005	J BASIC	ØH	ØN	P BASIC	APPROX WEIGHT LB/100
-02	.125	3125-24 UNJF-3B	.553-.564	.219	.631	.047	.240	.562	.322	.110	.43
-03	.188	375-24 UNJF-3B	.616-.627	.219	.703	.047	.270	.625	.385	.110	.49
-04	.250	.4375-20 UNJF-3B	.679-.690	.250	.775	.047	.305	.688	.448	.125	.66
-05	.312	500-20 UNJF-3B	.741-.752	.250	.846	.055	.340	.750	.510	.125	.75
-06	.375	5625-18 UNJF-3B	.803-.814	.266	.916	.055	.370	.812	.572	.133	.88
-07	.438	.625-18 UNJF-3B	.865-.877	.266	.987	.055	.405	.875	.635	.133	.99
-08	.500	750-16 UNJF-3B	.990-1.002	.312	1.130	.062	.470	1.000	.760	.157	1.39
-09	.562	8125-16 UNJ-3P	1.052-1.064	.312	1.200	.062	.500	1.062	.822	.157	1.47
-10	.625	.875-14 UNJF-3P	1.114-1.127	.359	1.271	.062	.540	1.125	.885	.180	1.89
-11	.688	1.000-12 UNJF-3B	1.301-1.314	.406	1.484	.070	.625	1.312	1.010	.204	3.06
-12	.750	1.0625-12 UNJ-3B	1.364-1.377	.406	1.556	.070	.660	1.375	1.072	.204	3.26
-14	.875	1.1875-12 UNJ-3B	1.489-1.502	.406	1.699	.070	.725	1.500	1.198	.204	3.64
-16	1.000	1.3125-12 UNJ-3P	1.614-1.627	.406	1.842	.070	.790	1.625	1.322	.204	4.07
-18	1.125	1.500-12 UNJF-3B	1.800-1.814	.406	2.054	.070	.890	1.812	1.510	.204	4.70
-20	1.250	1.625-12 UNJ-3B	1.926-1.940	.406	2.198	.070	.960	1.938	1.635	.204	5.15
-24	1.500	1.875-12 UNJ-3P	2.176-2.190	.406	2.483	.070	1.095	2.188	1.885	.204	6.06
-2P	1.750	2.250-12 UNJ-3P	2.549-2.564	.406	2.908	.070	1.295	2.562	2.260	.204	7.47
-32	2.000	2.500-12 UNJ-3E	2.799-2.814	.406	3.194	.070	1.425	2.812	2.510	.204	8.47

USER ACTIVITIES
ARMY-AT, ER, ME

REVIEWER ACTIVITIES
AIR FORCE - B2
DLA-IS

DISTRIBUTION STATEMENT A. Approved for public release; distribution is unlimited.
This military standard is approved for use by all Departments and Agencies of the Department of Defense.
Selection for all new engineering and design applications and for repetitive use shall be made from this document when applicable.

© ENTIRE STANDARD REVISED

PA NAVY-AS Other Cust ARMY-AV	INTERNATIONAL INTEREST	TITLE NUT, PLAIN, HEX, BOSS CONNECTION, ALUMINUM	MILITARY STANDARD MS9200
PROCUREMENT SPECIFICATION NONE	SUPERSEDES	PAGE 1	OF 2

APPROVED 15 OCT 58 REVISED 30 SEP 86

AMSC N/A

DD FORM 672-1 (COORDINATED)

PREVIOUS EDITIONS ARE OBSOLETE

5310-1561

USER ACTIVITIES
ARMY - AT, ER, ME

REVIEWER ACTIVITIES
AIR FORCE - 6Z
DLA - 1S

This military standard is approved for use by all Departments and Agencies of the Department of Defense. Selection for all new engineering and design applications and for replacement use shall be made from this document.

FED SUP CLASS
5310

REQUIREMENTS:

1. MATERIAL ALUMINUM IN ACCORDANCE WITH AMS 4121-78
2. FINISH ANODIC TREATMENT IN ACCORDANCE WITH AMS 2470-84
3. THREADS THREADS SHALL BE IN ACCORDANCE WITH MIL-S-8879
4. SURFACE TEXTURE SURFACE TEXTURE SHALL BE IN ACCORDANCE WITH AS291-64
5. MARKING IN MULTIPLE MARKING OF BAR STOCK, DUPLICATION OF WHOLE OR PART OF SYMBOL OR OFFSET OF SYMBOL SUCH THAT UPPER PORTION APPEARS BELOW LOWER PORTION ON FINISHED PART IS PERMISSIBLE PROVIDED POSITIVE IDENTIFICATION IS SHOWN PARTS SHALL BE MARKED BEFORE THREADING
6. EDGES BREAK SHARP EDGES .003-.015, UNLESS OTHERWISE SPECIFIED
7. TOLERANCES UNLESS OTHERWISE SPECIFIED, TOLERANCES FOR LINEAR DIMENSIONS $\pm .010$, FOR ANGULAR DIMENSIONS $\pm 5^\circ$
8. PART NUMBER THE PART NUMBER SHALL CONSIST OF THE BASIC MS NUMBER FOLLOWED BY A DASH NUMBER FROM TABLE I

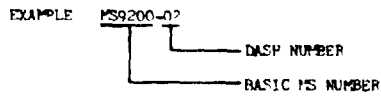

MS9200-02 INDICATES - NUT, PLAIN, HEXAGON BOSS CONNECTION, 7125-24 UNJF-3P

NOTES

1. ALL DIMENSIONS ARE IN INCHES
2. DO NOT USE UNASSIGNED PART NUMBERS
3. IN THE EVENT OF A CONFLICT BETWEEN THE TEXT OF THIS STANDARD AND THE REFERENCES CITED HEREIN, THE TEXT OF THIS STANDARD SHALL TAKE PRECEDENCE
4. REFERENCED GOVERNMENT (OR NONGOVERNMENT) DOCUMENTS OF THE ISSUE LISTED IN THAT ISSUE OF THE DEPARTMENT OF DEFENSE INDEX OF SPECIFICATIONS AND STANDARDS (DODISS) SPECIFIED IN THE SOLICITATION FORM A PART OF THIS STANDARD TO THE EXTENT SPECIFIED HEREIN
5. THIS STANDARD WAS DEVELOPED COOPERATIVELY WITH THE ENGINE AND PROPELLER UTILITY PARTS COMMITTEE OF THE SAF
6. AS AND AMS ARE SAE PUBLICATIONS

APPROVED 15 OCT 58 REVISED (C) FOR CHANGES SEE PAGES 1 AND 2

P A Other Code NAVY-AS ARMY-AV	INTERNATIONAL INTEREST	TITLE NUT, PLAIN, HEX, BOSS CONNECTION, ALUMINUM	MILITARY STANDARD
			MS9200
PROCUREMENT SPECIFICATION NONE		SUPERSEDED	PAGE 2 OF 2