

FED SUP CLASS
5975

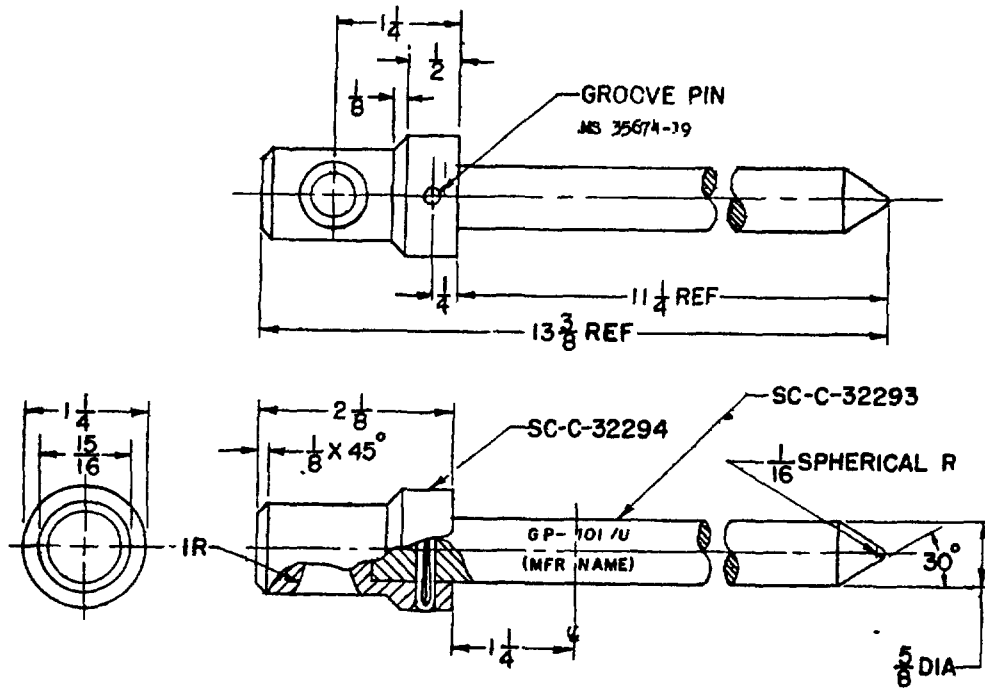

DASH NO.	REQD	DESCRIPTION	MATERIAL	SIGNAL CORPS DRAWING NO.	FIN
-1	1	STAKE	ALUM ALLOY	SC-C-32293	
	1	CAP	STEEL	SC-C-32294	
	1	GROOVE PIN	STEEL	MS 35674-19	

NOTES:

1. AFTER ASSEMBLY FINISH SEMI-GLOSS GROUND ENAMEL PER SPECIFICATION MIL-T-704 PARA 3.3.4.1
2. MARKING IN ACCORDANCE WITH MIL-STD-130; AFTER FINISH IS APPLIED FILL CHARACTERS WITH A PERMANENT WHITE
3. REFERENCED DOCUMENT SHALL BE OF THE ISSUE IN EFFECT ON DATE OF INVITATION FOR BIDS.
4. THIS STANDARD TAKES PRECEDENCE OVER DOCUMENT REFERENCED HEREIN.
5. THIS DOCUMENT HAS BEEN PROMULGATED BY THE DEPARTMENT OF DEFENSE AS THE MILITARY STANDARD TO LIMIT THE SELECTION OF THE ITEM, PRODUCT, OR DESIGN COVERED HEREIN IN ENGINEERING, DESIGN, AND PROCUREMENT. THIS STANDARD SHALL BECOME EFFECTIVE NOT LATER THAN 30 DAYS AFTER THE LATEST DATE OF APPROVAL SHOWN.

APPROVED 2 Feb 60 REVISED

ALL DIMENSIONS IN INCHES.

TOLERANCES ON FRACTIONS ± 1/64, ANGLE 0°30' UNLESS OTHERWISE SPECIFIED

CUSTOMERS
S1gC
MC
USAF

OTHER INT.
I-EO
I-
N-

MILITARY STANDARD
STAKE, GUY, ANTENNA
(STAKE GP-101/U)

MS 75015

PROCUREMENT SPECIFICATION
MIL-S-55094

IMPRESSES:

SHEET 1 OF 1

When Government drawings, specifications, or other data are used for any purpose other than in connection with a definitely related Government procurement operation, the United States Government thereby incurs no responsibility, nor any obligation whatsoever, and the fact that the Government may have furnished certain data shall not be construed as an implied or otherwise contract or as an authorization of the Government to be reproduced or transmitted in any form or by any means electronic or mechanical, including photocopying, recording, or by any information storage and retrieval system, without permission in writing from the Government.