

USER ACTIVITIES: ARMY-ME; NAVY-MC, YD

This military standard is approved for use by all Departments and Agencies of the Department of Defense. Selection for all new engineering and design applications and for repetitive use shall be made from this document.

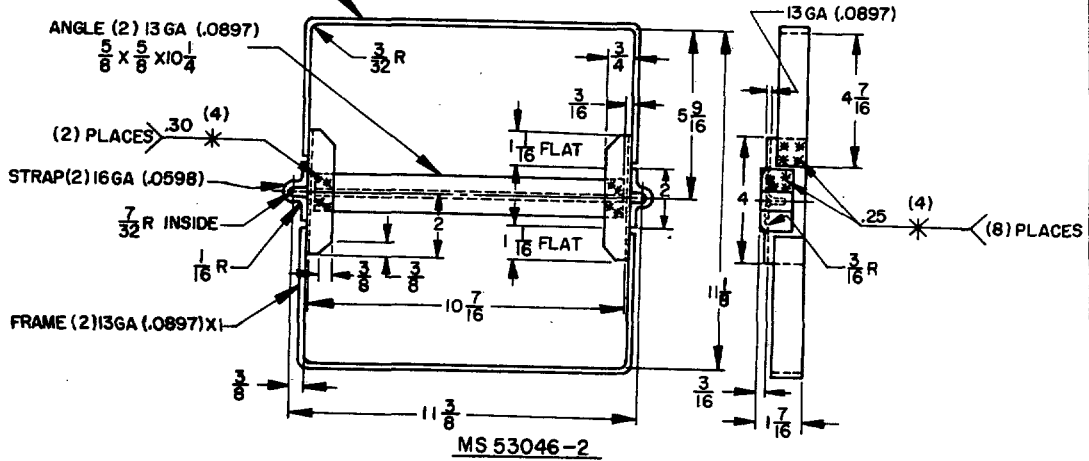
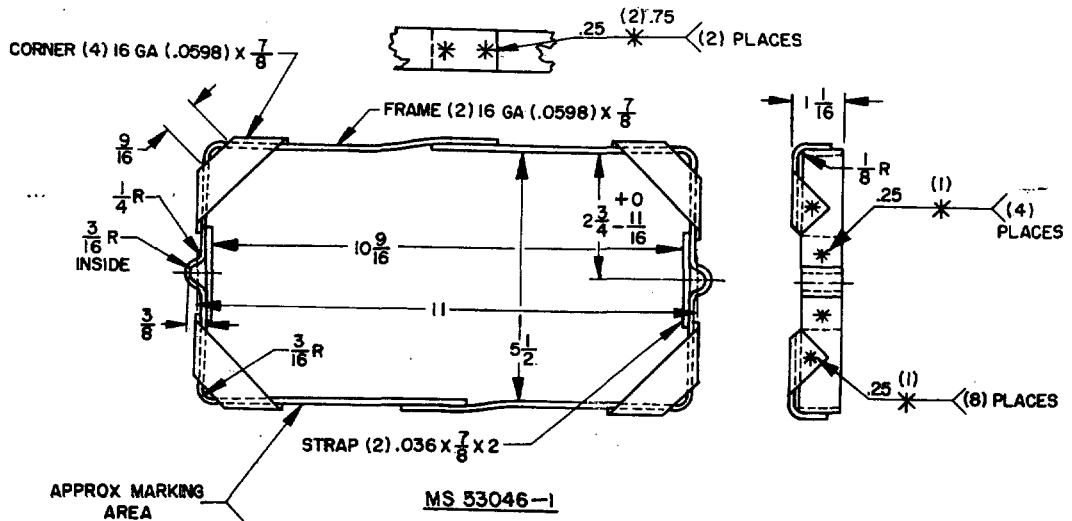

MS PART NO	FORMER ARMY PART NO	BATTERY TYPE NORMALLY USED
MS 53046-1	8754765	2 HN (SINGLE)
MS 53046-2	7415701	2 HN (DOUBLE)
MS 53046-3	8345000 11639629	6 TN (DOUBLE)

© FOR CHANGES SEE SHEET 2

P.A. ARMY-AT Other Cust AF-84	TITLE <b>RETAINER, BATTERY—AUTOMOTIVE TACTICAL VEHICLES</b>	<b>MILITARY STANDARD</b> <b>MS 53046</b>
PROCUREMENT SPECIFICATION NONE	SUPERSEDES:	SHEET 1 OF 2

FED. SUP CLASS  
2590

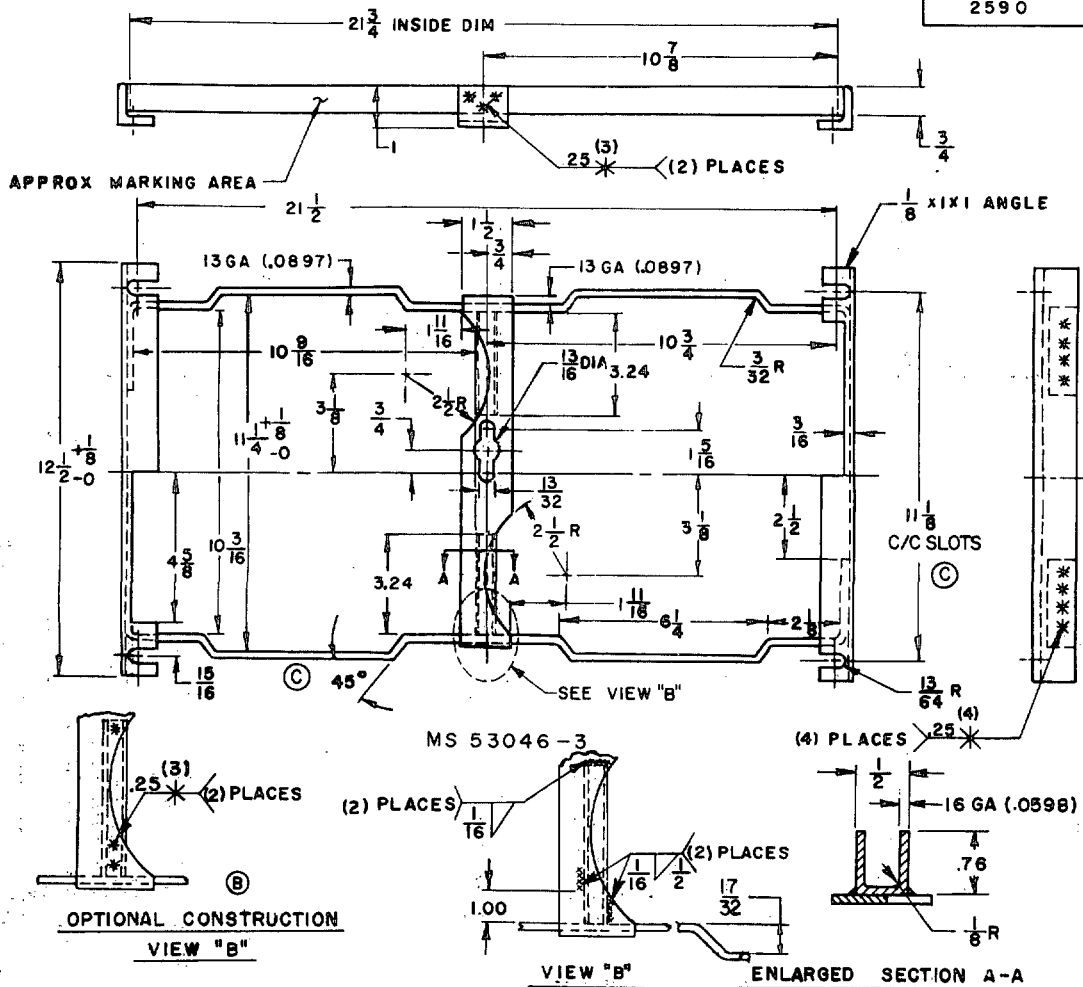

NOTES:

1. MATERIAL: STEEL, CARBON, HRCQ, P&O SHEET OR STRIP, CRCQ SHEET OR CR STRIP, 1009 TO 1020, TEMPER 2 TO 5, PER QQ-S-698.
2. WELD PER CLASS 2 OF MIL-STD-1261. SPOTWELD AS SHOWN PER MIL-W-12332.
3. FINISH: CLEAN PER TT-C-490. APPLY PLASTISOL COATING .025 THICK PER TYPE II, CLASS 1 OF MIL-P-20689. OPTIONAL: RUBBER DIP COAT WITH POLYCHLOROPRENE .025 THICK, GRADE SC 515 F1 PER MIL-R-3065 AND MIL-STD-417.
4. DIMENSIONS ARE IN INCHES. UNLESS OTHERWISE SPECIFIED, TOLERANCES ARE  $\pm 1/32$ .
5. FOR DESIGN FEATURE PURPOSES, THIS STANDARD TAKES PRECEDENCE OVER PROCUREMENT DOCUMENTS REFERENCED HEREIN.
6. THIS STANDARD IS NOT INTENDED TO LIMIT CONSTRUCTION TO FEATURES OTHER THAN AS SHOWN HEREON BY DIMENSIONS, NOTATIONS, OR REFERENCED DOCUMENTS.
7. REFERENCED DOCUMENTS SHALL BE OF THE ISSUE IN EFFECT ON DATE OF INVITATIONS FOR BID.
8. MARKING SHALL CONSIST OF THE MS PART NUMBER AND MANUFACTURER'S IDENTIFICATION IN ACCORDANCE WITH MIL-STD-130.

APPROVED 30 OCTOBER 1962 REVISED (C) FOR CHANGES SEE SHEET 2

P.A. ARMY-AT Other Cust AF-84	TITLE RETAINER, BATTERY— AUTOMOTIVE TACTICAL VEHICLES	MILITARY STANDARD <b>MS 53046</b>
PROCUREMENT SPECIFICATION NONE	SUPERSEDES:	SHEET 2 OF 2