

The requirements for acquiring the product(s) described herein shall consist of this specification sheet and the issue of the following specification listed in that issue of the DoDISS specified in the solicitation: MIL-L-14465

This specification is approved for use by all Departments and Agencies of the Department of Defense.

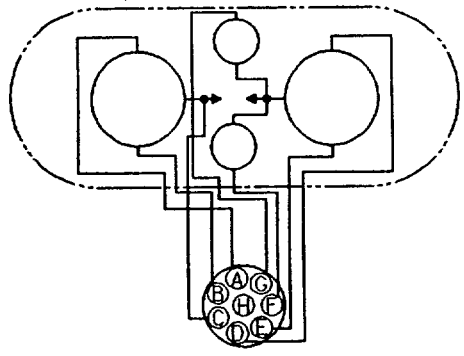
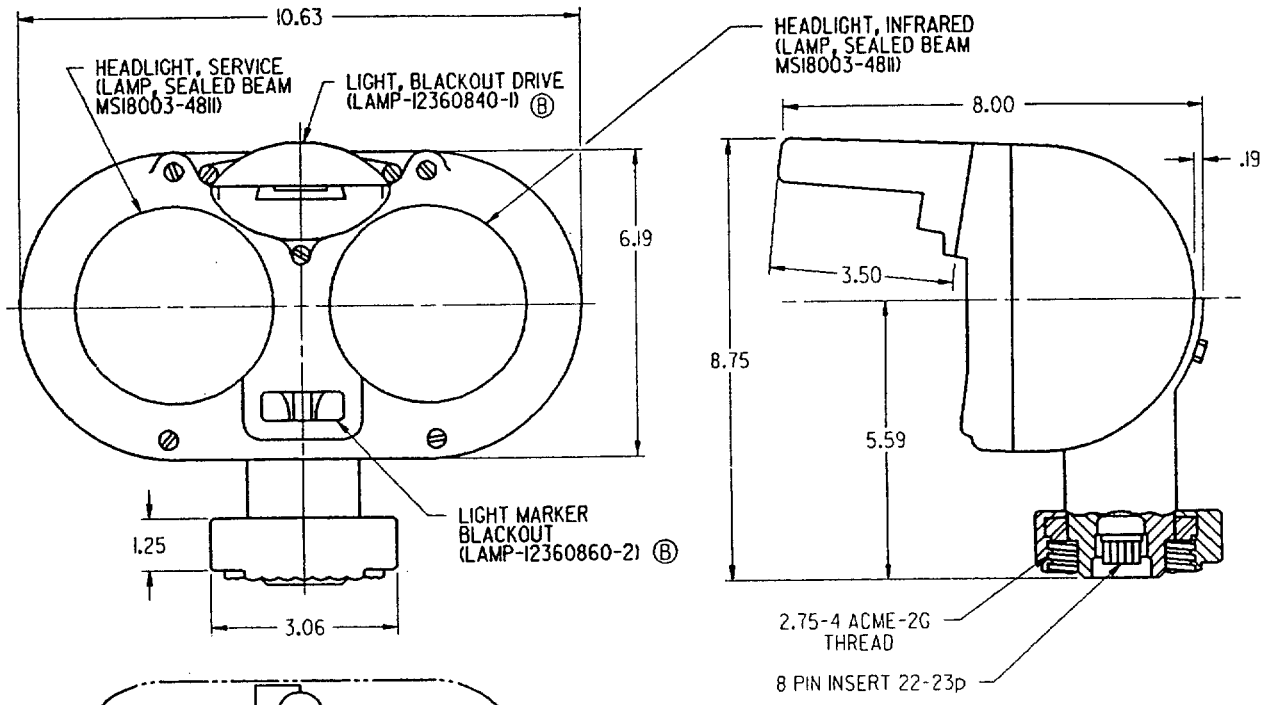

SCHEMATIC DIAGRAM

PIN	CIRCUIT DESCRIPTION	CIRCUIT NUMBER
A	HEADLIGHT, SERVICE (LOW BEAM)	18
B	HEADLIGHT, SERVICE (HIGH BEAM)	17
C	GROUND	91
D	HEADLIGHT, INFRARED LOW BEAM	515
E	HEADLIGHT, INFRARED HIGH BEAM	514
F	LIGHT, MARKER, BLACKOUT	20
G	LIGHT, DRIVING, BLACKOUT	19
H	DUMMY	-

NOTES:

1. TYPE I (QUICK DETACHABLE) OF PROCUREMENT SPECIFICATION.
2. THREADS SHALL BE IN ACCORDANCE WITH SCREW THREAD STANDARDS FOR FEDERAL SERVICES HANDBOOK H28
3. DIMENSIONS ARE IN INCHES, UNLESS OTHERWISE SPECIFIED, TOLERANCES ARE $\pm 1/16$.
4. FOR DESIGN FEATURE PURPOSES, THIS STANDARD TAKES PRECEDENCE OVER PROCUREMENT DOCUMENTS REFERENCED HEREIN.
5. REFERENCED DOCUMENTS SHALL BE OF THE ISSUE IN EFFECT ON DATE OF INVITATIONS FOR BID.
6. MARKINGS SHALL CONSIST OF THE MS PART NUMBER AND MANUFACTURER'S IDENTIFICATION IN ACCORDANCE WITH MIL-STD-130.
7. DETAILS OF THIS ASSEMBLY SHALL BE IN ACCORDANCE WITH REFERENCED ENGINEERING PARTS LIST WHICH MAY BE OBTAINED FROM THE U.S. ARMY TANK-AUTOMOTIVE COMMAND, WARREN, MICHIGAN 48090.

(B) DENOTES CHANGES

MS PART NO.	ENGINEERING PARTS LIST
MS53022-1	7972325

PREPARING ACTIVITY: ARMY-AT CUSTODIANS: ARMY- AT NAVY- MC AIR FORCE- DLA- REVIEW: USER: PROJECT NUMBER: 6220-1045	MILITARY SPECIFICATION SHEET TITLE: LIGHT, COMPOSITE, VEHICULAR-BLACKOUT DRIVING, BLACKOUT MARKER, SERVICE, INFRARED -24 VOLT	SPECIFICATION SHEET NUMBER: MS53022B 12 JUNE 1992
		SUPERSEDING: MS53022A 22 AUGUST 1968
		AMSC-NA FSC-6220