

FED. SUP CLASS  
5307

REVIEW ACTIVITY: DSA-IS: ARMY-MI  
USER ACTIVITIES: ARMY- ME, WC

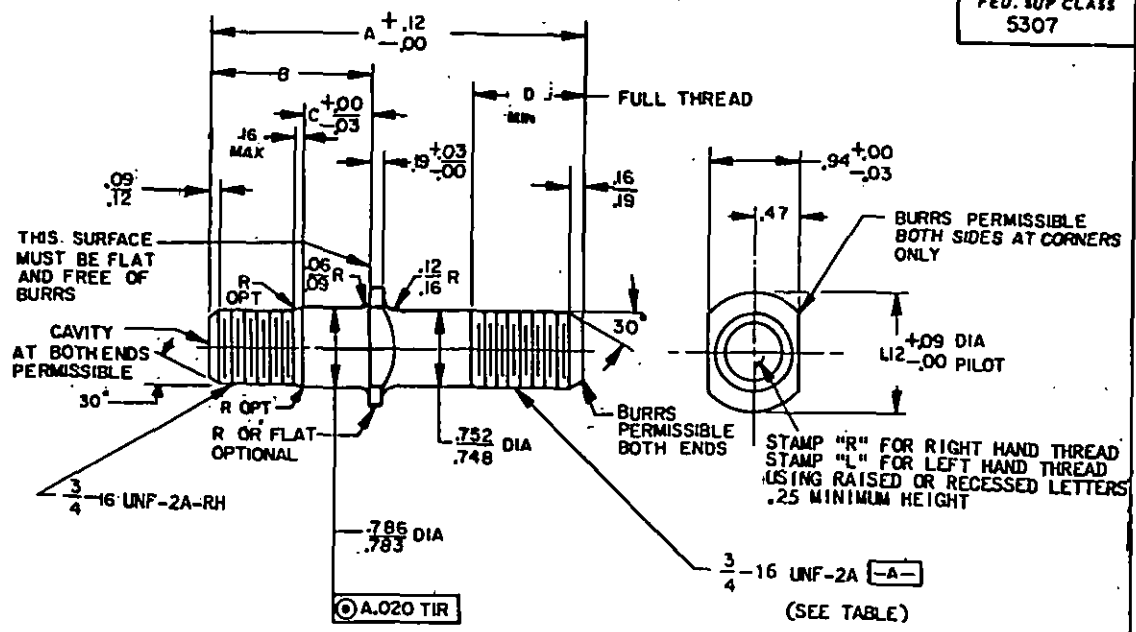

MS PART NO.	FORMER PART NO.	A	B	C	D	THREAD
MS 51950-1	537858	3.59	2.06	.88	1.14	LH
MS 51950-2	537857	3.59	2.06	.88	1.14	RH
MS 51950-3	8332188	3.81	1.63	.72	1.20	LH
MS 51950-4	8332189	3.81	1.63	.72	1.20	RH
MS 51950-5	537868	4.03	2.50	1.50	1.14	LH
MS 51950-6	537867	4.03	2.50	1.50	1.14	RH

(C)

REQUIREMENTS:

1. THE MATERIAL SHALL BE STEEL ALLOY 4135, 4137, 4140, 5135, 5140, 8637, 8640, 8740 PER ASTM A322 OR 4135, 4137, 4140, 8637, 8640, 8740 PER ASTM A547 OR 4135, 4137, 4140, 5135, 5140, 8637, 8640, 8740 PER MIL-S-46172 FORGING GRADE D.
2. HEAT TREATMENT: QUENCH HARDEN AND TEMPER CORE HARDNESS RHC 28-34. SURFACE CARBON RESTORATION IN NON-NITRIDING ATMOSPHERE PERMISSIBLE, IF NECESSARY.
3. MECHANICAL AND PERFORMANCE REQUIREMENTS: MINIMUM PROOF LOAD 85,000 PSI. MINIMUM AXIAL TENSILE STRENGTH 120,000 PSI. BEND TEST STUD SHALL WITHSTAND A TEN DEGREE BEND WITHOUT BREAKING WHEN HELD IN A VISE WITH THREE THREADS EXPOSED.
4. ALL THREADS SHALL BE ROLLED; THREADS TO BE IN ACCORDANCE WITH FEDERAL SERVICES HANDBOOK H28.
5. PROTECTIVE FINISH: ZINC PLATE PER QQ-Z-325, TYPE II CLASS 2 OR CADMIUM PLATE PER QQ-P-416, TYPE II CLASS 2. HYDROGEN EMBRITTLEMENT RELIEF REQUIRED WITHIN FOUR HOURS AFTER PLATING.
6. MARKING SHALL CONSIST OF THE MS PART NUMBER AND MANUFACTURER'S IDENTIFICATION IN ACCORDANCE WITH MIL-STD-130.

NOTES:

1. DIMENSIONS ARE IN INCHES. UNLESS OTHERWISE SPECIFIED, TOLERANCES ARE ± .01 ON DECIMALS, ± 1° ON ANGULAR DIMENSIONS.
2. THIS STANDARD IS NOT INTENDED TO LIMIT CONSTRUCTION FEATURES OTHER THAN AS SHOWN HEREON BY DIMENSIONS, NOTATIONS, AND REFERENCED DOCUMENTS.
3. REFERENCED DOCUMENTS SHALL BE OF THE ISSUE IN EFFECT ON DATE OF INVITATIONS FOR BIDS, OR REQUEST FOR PROPOSAL, EXCEPT THAT REFERENCED ADOPTED INDUSTRY DOCUMENTS SHALL GIVE THE DATE OF THE ISSUE ADOPTED.

military standard is approved for use by all Departments and Agencies in the Department of Defense. Selection for all new engineering and design applications and for repetitive use shall be made from this document.

P.A. ARMY-AT Other Cost AF-99	TITLE <b>STUD, SHOULDERED: WHEEL MOUNTING</b>	<b>MILITARY STANDARD MS 51950</b>
PROCUREMENT SPECIFICATION NONE	SUPERSEDES: 537857, 537858, 537867, 537868, 8332188, 8332189	SHEET 1 OF 1

DD FORM 1 SEP 62 672-1

PREVIOUS EDITIONS OF THIS FORM ARE OBSOLETE.

APPROVED 8 AUGUST 1963 REVISED (A) 11 MAY 1971 (B) 28 JUNE 1976 (C) 28 JAN 1977