

INCH-POUND

MS51832D  
 14 August 2012  
 SUPERSEDING  
 MS51832C  
 9 March 1992

## DETAIL SPECIFICATION SHEET

INSERT, SCREW – THREAD, LOCKED IN, KEY-LOCKED,  
 EXTRA HEAVY DUTY

This specification is approved for use by all Departments and Agencies of the Department of Defense.

The requirements for acquiring the product described herein shall consist of this specification sheet and procurement specification MIL-I-45914.

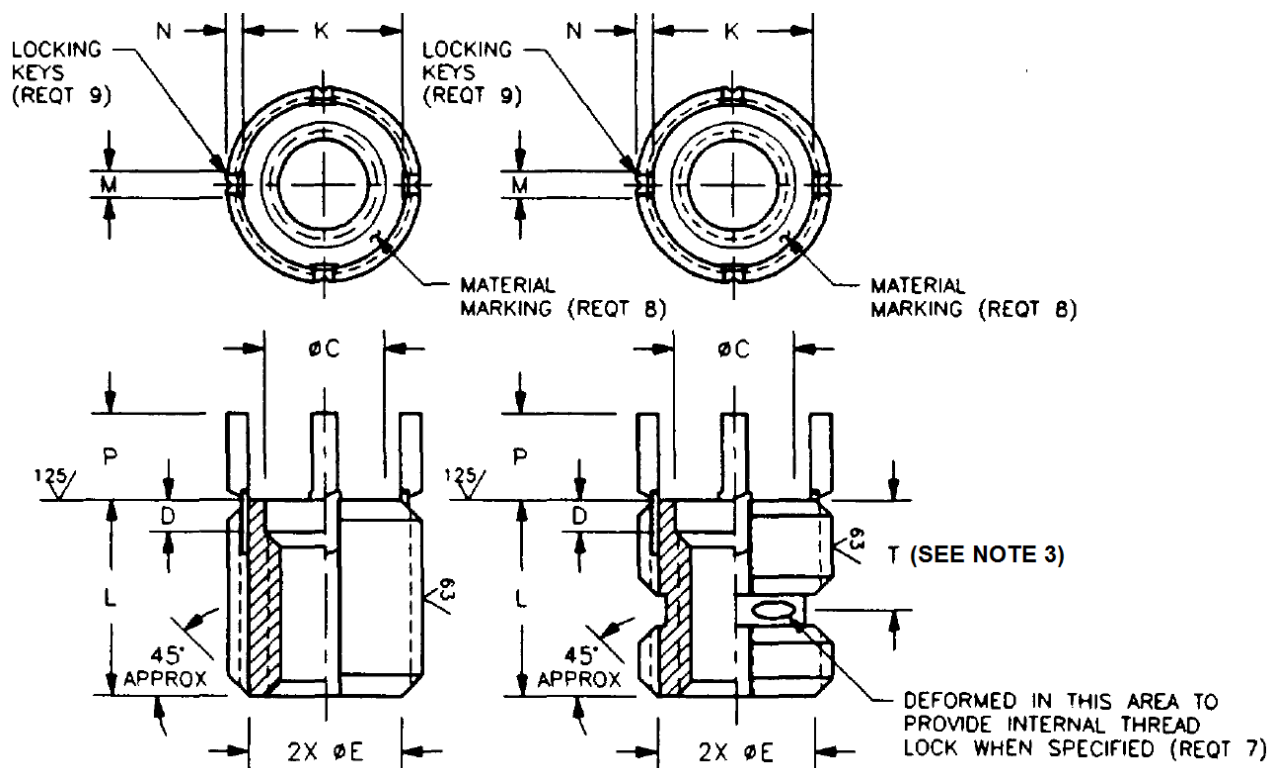

FIGURE 1. INSERT, COARSE INTERNAL THREADS.

## MS51832D

TABLE I. COARSE INTERNAL THREADS.

DASH NO.	INTERNAL THREAD SAE AS8879 UNJC-3B	EXTERNAL THREAD FED-STD-H28/2 EXCEPT MODIFIED MINOR DIA.		ØC ±.005	D ±.010	ØE REF	K REF	L ±.015	KEY DIMENSIONS			T ±.030
		SIZE	MINOR DIA.						M REF	N REF	P REF	
101	.190-24	.4375-14UNC-2A	.383 .375	.196	.070	.375	.344	.312	.068	.040	.130	.220
102	.250-20	.500-13UNC-2A	.440 .432	.257	.070	.430	.407	.375	.068	.040	.190	.220
103	.3125-18	.5625-12UNC-2A	.503 .495	.316	.070	.495	.469	.437	.068	.040	.190	.220
104	.375-16	.625-11UNC-2A	.565 .551	.380	.070	.550	.532	.500	.068	.040	.190	.250
105	.4375-14	.6875-11NS-2A	.625 .615	.445	.100	.615	.595	.625	.068	.040	.190	.280
106	.500-13	.8125-16UN-2A	.752 .744	.507	.100	.745	.720	.688	.068	.040	.190	.280
107	.5625-12	.875-14UNF-2A	.815 .807	.580	.100	.805	.782	.812	.068	.040	.190	.320
108	.625-11	1.000-12UNF-2A	.924 .916	.640	.100	.915	.850	.875	.103	.070	.250	.330
109	.750-10	1.250-12UNF-2A	1.175 1.165	.763	.100	1.165	1.100	1.125	.103	.070	.250	---
109L	.750-10	1.250-12UNF-2A	1.175 1.165	.763	.100	1.165	1.100	1.250	.103	.070	.250	.490
110	.875-9	1.375-12UNF-2A	1.300 1.290	.888	.100	1.290	1.225	1.250	.103	.070	.250	---
110L	.875-9	1.375-12 UNF-2A	1.300 1.290	.888	.100	1.290	1.225	1.375	.103	.070	.250	.490
111	1.000-8	1.500-12UNF-2A	1.424 1.415	1.015	.100	1.415	1.350	1.375	.103	.070	.250	---
111L	1.000-8	1.500-12UNF-2A	1.424 1.416	1.015	.100	1.415	1.350	1.500	.103	.070	.250	.550

## MS51832D

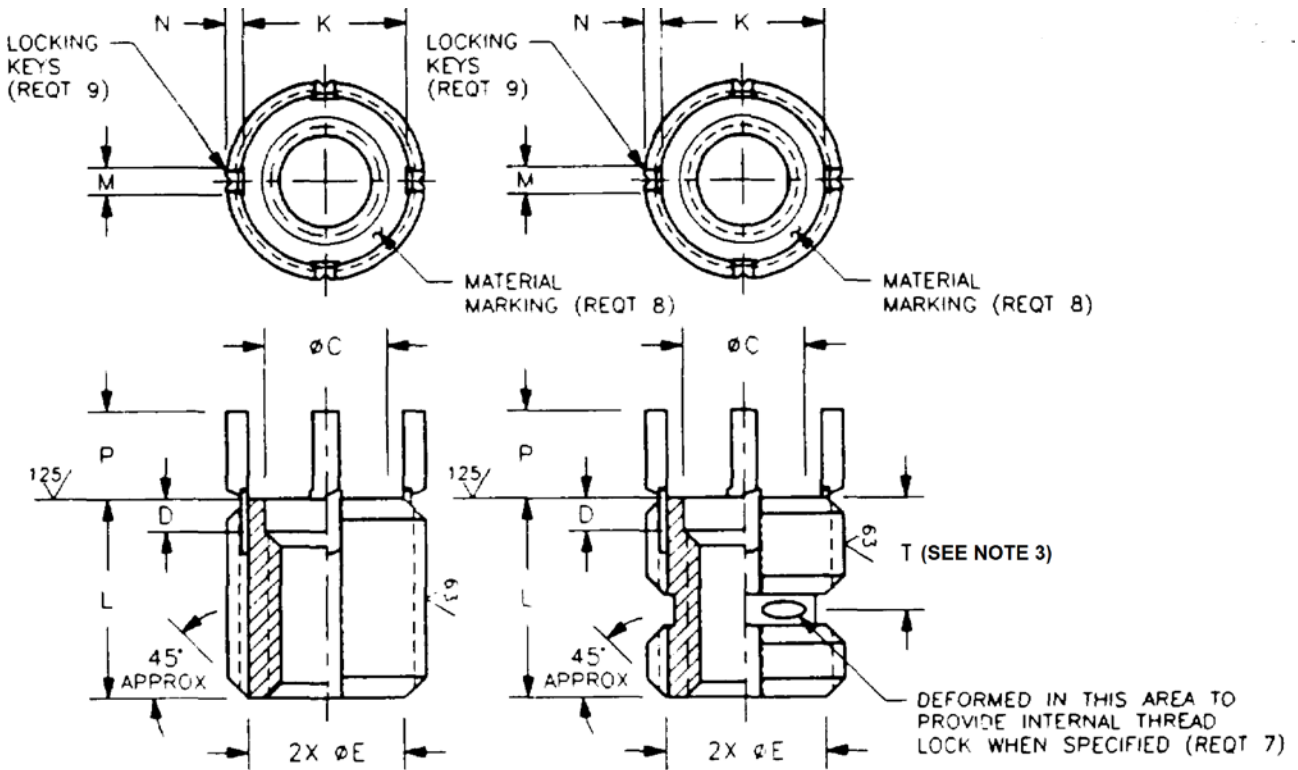

FIGURE 2. INSERT, FINE INTERNAL THREADS.

TABLE II. FINE INTERNAL THREADS.

DASH NO.	INTERNAL THREAD SAE AS8879 UNJF-3B	EXTERNAL THREAD FED-STD-H28/2 EXCEPT MODIFIED MINOR DIA.		ØC ±.005	D ±.010	ØE REF	K REF	L ±.015	KEY DIMENSIONS			T ±.030
		SIZE	MINOR DIA						M REF	N REF	P REF	
201	.190-32	.4375-14UNC-2A	.383 .375	.196	.070	.375	.344	.312	.068	.040	.130	.220
202	.250-28	.500-13UNC-2A	.440 .432	.257	.070	.430	.407	.375	.068	.040	.190	.220
203	.3125-24	.5625-12UNC-2A	.503 .495	.316	.070	.495	.469	.437	.068	.040	.190	.220
204	.375-24	.625-11UNC-2A	.565 .551	.380	.070	.550	.532	.500	.068	.040	.190	.250
205	.4375-20	.6875-11NS-2A	.625 .615	.445	.100	.615	.595	.625	.068	.040	.190	.280
206	.500-20	.8125-16UN-2A	.752 .744	.507	.100	.745	.720	.688	.068	.040	.190	.280
207	.5625-18	.875-14UNF-2A	.815 .807	.580	.100	.805	.782	.812	.068	.040	.190	.320
208	.625-18	1.000-12UNF-2A	.924 .916	.640	.100	.915	.850	.875	.103	.070	.250	.330
209	.750-16	1.250-12UNF-2A	1.175 1.165	.763	.100	1.165	1.100	1.125	.103	.070	.250	---
209L	.750-16	1.250-12UNF-2A	1.175 1.165	.763	.100	1.165	1.100	1.250	.103	.070	.250	.490
210	.875-14	1.375-12UNF-2A	1.300 1.290	.888	.100	1.290	1.225	1.250	.103	.070	.250	---
210L	.875-14	1.375-12UNF-2A	1.300 1.290	.888	.100	1.290	1.225	1.375	.103	.070	.250	.490
211	1.000-12	1.500-12UNF-2A	1.424 1.416	1.015	.100	1.415	1.350	1.375	.103	.070	.250	---
211L	1.000-12	1.500-12UNF-2A	1.424 1.416	1.015	.100	1.415	1.350	1.500	.103	.070	.250	.550

## MS51832D

## Requirements:

1. Material. Steel, corrosion-resistant, Type 303 (UNS S30300) in accordance with chemical composition of SAE AMS 5640 (Type 1) or ASTM A582/A582M, or Type 303SE (UNS S30323) in accordance with chemical composition of SAE AMS 5640 (Type 2), SAE AMS 5738 or ASTM A582/A582M.  
  
Steel, corrosion-resistant. Type A286 (UNS S66286) in accordance with SAE AMS 5731, SAE AMS 5734 or SAE AMS 5737.  
  
Steel, alloy, grade 4140 (UNS G41400) in accordance with SAE AMS 6349 or SAE AMS 6382 or grade 8740 (UNS G87400) in accordance with SAE AMS 6322.  
  
Locking keys: steel, corrosion-resistant. Type 302 chemical composition of ASTM A580/A580M only.
2. Cadmium plating and surface treatment. Corrosion-resistant steel shall be passivated in accordance with SAE AMS2700. Alloy steel shall be cadmium plated in accordance with SAE AMS-QQ-P-416, Type II, Class 3. The locking keys may or may not be cadmium plated.
3. Lubrication. Inserts with self-locking internal threads shall be dry film lubricated in accordance with MIL-PRF-46010, Type I. The locking keys may or may not be lubricated.
4. Surface texture: Machined surfaces shall be in accordance with ASME B46.1.
5. Heat treatment: Alloy steel inserts shall be heat treated to 160,000 psi Ft<sub>u</sub> minimum in accordance with SAE AMS-H- 6875. Corrosion-resistant steel inserts, type A286 (SAE AMS 5734). Shall be heat treated to 140,000 psi Ft<sub>u</sub> minimum.
6. Hardness. Alloy steel inserts shall have a hardness range of 36-40 HRC.
7. Part number. The part number shall consist of the basic MS sheet number plus the dash number taken from table I or table II, as applicable:

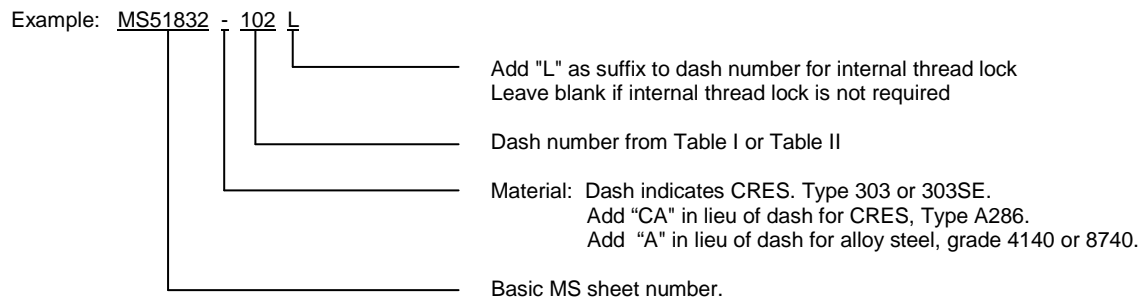

Example: MS51832CA102L indicates - Insert, Screw-Thread, Locked In, Key-Locked, Lightweight, CRES A286, .250-20UNJC-3B internal thread with internal thread lock feature.

8. Material marking: CRES 303 or 303SE has no identifying mark.  
CRES A286 shall be identified on top of insert by one (1) line or dash mark.  
Alloy steel 4140 or 8740 shall be identified on top of insert by two (2) parallel lines or dash marks.  
Material marking of miniature type optional.
9. Inserts with internal thread size .190 and smaller shall be supplied with two (2) locking keys spaced 180° apart.  
Inserts with internal thread size .250 and greater shall be supplied with four (4) locking keys spaced 90° apart.
10. Inserts shall be free of all hanging burrs and slivers which might become dislodged under usage.
11. Source identification mark: Source identification mark shall be in accordance with MIL-I-45914.
12. All dimensions are after cadmium plating or surface treatment and prior to the addition of the lubrication.
13. Fillets are R .015 maximum.

## MS51832D

### Notes:

1. All dimensions are in inches.
2. Installation of inserts shall be in accordance with MS51835.
3. Distance to center of internal thread lock.
4. In the event of a conflict between the text of this standard and the references cited herein, the text of this standard shall take precedence.
5. CHANGES FROM PREVIOUS ISSUE. Marginal notations are not used in this revision to identify changes with respect to the previous issue due to the extent of the changes.

### MILITARY INTEREST

#### Custodians:

Army - AR  
Navy - AS  
Air Force - 99

#### Preparing activity:

DLA - IS

(Project 5325-2012-013)

#### Review activities:

Army – AT, AV, CR, MI  
Navy – EC, MC, SH  
Air Force - 71

NOTE: The activities listed above were interested in this document as of the date of this document. Since organizations and responsibilities can change, you should verify the currency of the information above using the ASSIST Online database at <https://assist.dla.mil>.