

INCH-POUND

MS51831G  
w/AMENDMENT 1  
20 November 2012  
SUPERSEDING  
MS51831G  
14 August 2012

## DETAIL SPECIFICATION SHEET

INSERT, SCREW – THREAD, LOCKED IN, KEY LOCKED,  
HEAVY DUTY

This specification is approved for use by all Departments and Agencies of the Department of Defense.

The requirements for acquiring the product described herein shall consist of this specification sheet and procurement specification MIL-I-45914.

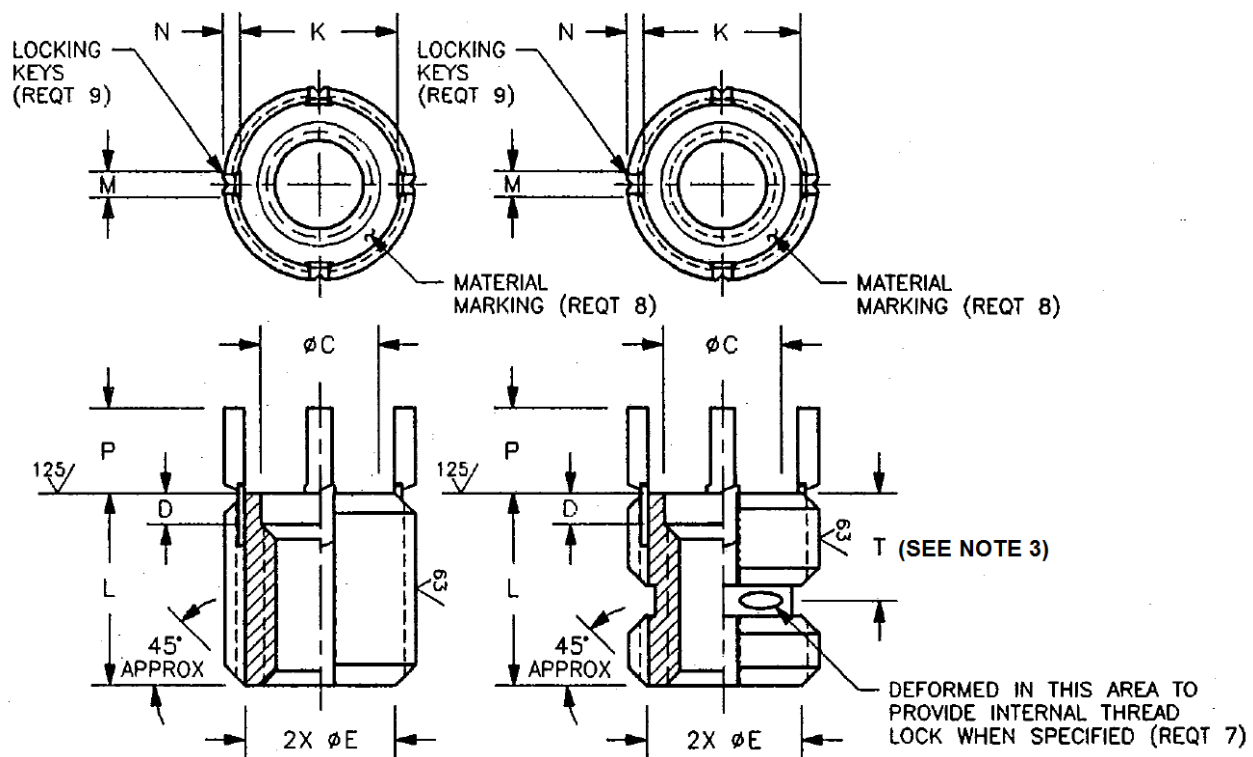

FIGURE 1. INSERT, COARSE INTERNAL THREADS.

MS51831G  
w/AMENDMENT 1

TABLE I. COARSE INTERNAL THREADS.

DASH NO.	INTERNAL THREAD SAE AS8879 UNJC-3B	EXTERNAL THREAD FED-STD-H28/2 EXCEPT MODIFIED MINOR DIA.		ØC ±.005	D ±.010	ØE REF	K REF	L ±.015	KEY DIMENSIONS			T ±.030
		SIZE	MINOR DIA						M REF	N REF	P REF	
101	.190-24	.375-16UNC-2A	.320 .312	.196	.070	.310	.284	.312	.068	.040	.130	.220
102	.250-20	.4375-14UNC-2A	.383 .375	.257	.070	.375	.344	.375	.068	.040	.190	.220
103	.3125-18	.500-13UNC-2A	.440 .432	.316	.070	.430	.407	.437	.068	.040	.190	.220
104	.375-16	.5625-12UNC-2A	.503 .495	.380	.070	.495	.469	.500	.068	.040	.190	.250
105	.4375-14	.625-11UNC-2A	.565 .551	.445	.100	.550	.532	.625	.068	.040	.190	.280
106	.500-13	.6875-11NS-2A	.625 .615	.507	.100	.615	.595	.688	.068	.040	.190	.280
107	.5625-12	.8125-16UN-2A	.752 .744	.580	.100	.745	.720	.812	.068	.040	.190	.320
108	.625-11	.875-14UNF-2A	.815 .807	.640	.100	.805	.782	.875	.068	.040	.190	.330
109	.750-10	1.125-12UNF-2A	1.050 1.040	.763	.100	1.040	.975	1.125	.103	.070	.250	---
109L	.750-10	1.125-12UNF-2A	1.050 1.040	.763	.100	1.040	.975	1.250	.103	.070	.250	.490
110	.875-9	1.250-12UNF-2A	1.175 1.165	.888	.100	1.165	1.100	1.250	.103	.070	.250	---
110L	.875-9	1.250-12UNF-2A	1.175 1.165	.888	.100	1.165	1.100	1.375	.103	.070	.250	.490
111	1.000-8	1.375-12UNF-2A	1.300 1.290	1.015	.100	1.290	1.225	1.375	.103	.070	.250	---
111L	1.000-8	1.375-12UNF-2A	1.300 1.290	1.015	.100	1.290	1.225	1.500	.103	.070	.250	.550

MS51831G  
w/AMENDMENT 1

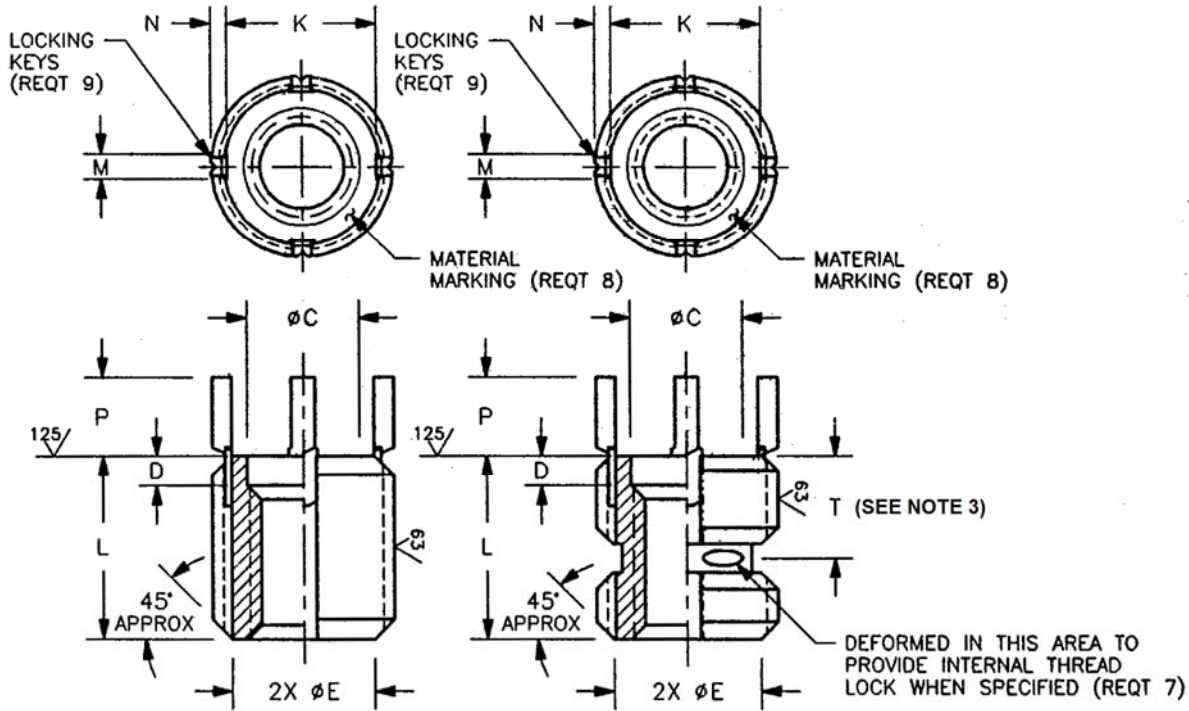

FIGURE 2. INSERT, FINE INTERNAL THREADS.

TABLE II. FINE INTERNAL THREADS.

DASH NO.	INTERNAL THREAD SAE AS8879 UNJF-3B	EXTERNAL THREAD FED-STD-H28/2 EXCEPT MODIFIED MINOR DIA.		ØC ±.005	D ±.010	ØE REF	K REF	L ±.015	KEY DIMENSIONS			T ±.030
		SIZE	MINOR DIA						M REF	N REF	P REF	
201	.190-32	.375-16UNC-2A	.320 .312	.196	.070	.310	.284	.312	.068	.040	.130	.220
202	.250-28	.4375-14UNC-2A	.383 .375	.257	.070	.375	.344	.375	.068	.040	.190	.220
203	.3125-24	.500-13UNC-2A	.440 .432	.316	.070	.430	.407	.437	.068	.040	.190	.220
204	.375-24	.5625-12UNC-2A	.503 .495	.380	.070	.495	.469	.500	.068	.040	.190	.250
205	.4375-20	.625-11UNC-2A	.565 .551	.445	.100	.550	.532	.625	.068	.040	.190	.280
206	.500-20	.6875-11NS-2A	.625 .615	.507	.100	.615	.595	.688	.068	.040	.190	.280
207	.5625-18	.8125-16UN-2A	.752 .744	.580	.100	.745	.720	.812	.068	.040	.190	.320
208	.625-18	.875-14UNF-2A	.815 .807	.640	.100	.805	.782	.875	.068	.040	.190	.330
209	.750-16	1.125-12UNF-2A	1.050 1.040	.763	.100	1.040	.975	1.125	.103	.070	.250	---
209L	.750-16	1.125-12UNF-2A	1.050 1.040	.763	.100	1.040	.975	1.250	.103	.070	.250	.490
210	.875-14	1.250-12UNF-2A	1.175 1.165	.888	.100	1.165	1.100	1.250	.103	.070	.250	---
210L	.875-14	1.250-12UNF-2A	1.175 1.165	.888	.100	1.165	1.100	1.375	.103	.070	.250	.490
211	1.000-12	1.375-12UNF-2A	1.300 1.290	1.015	.100	1.290	1.225	1.375	.103	.070	.250	---
211L	1.000-12	1.375-12UNF-2A	1.300 1.290	1.015	.100	1.290	1.225	1.500	.103	.070	.250	.550

**MS51831G**  
**w/AMENDMENT 1**

Requirements:

1. Material. Steel, corrosion-resistant, Type 303 (UNS 530300) in accordance with chemical composition of SAE AMS5640 (Type 1) or ASTM A582/A582M, or Type 303SE (UNS S30323) in accordance with chemical composition of SAE AMS5640 (Type 2), SAE AMS5738 or ASTM A582/A582M.  
  
Steel, corrosion-resistant. Type A286 (UNS S66286) in accordance with SAE AMS5731, SAE AMS5734 or SAE AMS5737.  
  
Steel, alloy, grade 4140 (UNS G41400) in accordance with SAE AMS6349 or SAE AMS6382 or grade 8740 (UNS G87400) in accordance with SAE AMS6322.  
  
Locking keys: steel, corrosion-resistant. Type 302 chemical composition of ASTM A580/A580M only.
2. Cadmium plating and surface treatment. Corrosion-resistant steel shall be passivated in accordance with SAE AMS2700. Alloy steel shall be cadmium plated in accordance with SAE AMS-QQ-P-416, Type II, Class 3. The locking keys may or may not be cadmium plated.
3. Lubrication. Inserts with self-locking internal threads for aerospace applications shall be dry film lubricated in accordance with SAE AS5272 Type I (See Note 5). Inserts with self-locking internal threads for non-aerospace applications shall be dry film lubricated in accordance with MIL-PRF-46010 (See Note 6). The locking keys may or may not be lubricated.
4. Surface texture: Machined surfaces shall be in accordance with ASME B46.1.
5. Heat treatment: Alloy steel inserts shall be heat treated to 160,000 psi Ft<sub>u</sub> minimum in accordance with SAE AMS-H- 6875. Corrosion-resistant steel inserts, type A286 (SAE AMS 5734) shall be heat treated to 140,000 psi Ft<sub>u</sub> minimum.
6. Hardness. Alloy steel inserts shall have a hardness range of 36-40 HRC.
7. Part number. The part number shall consist of the basic MS sheet number plus the dash number taken from Table I or Table II, as applicable:

Example: MS51831 - 106 L

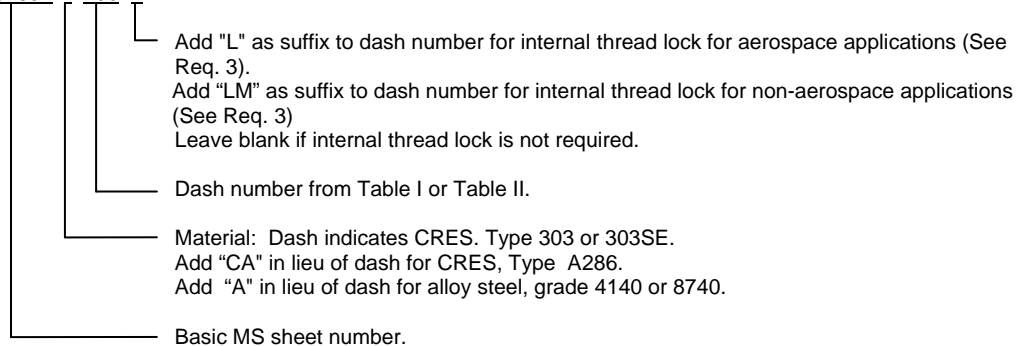

Example: MS51831CA102L indicates - Insert, Screw-Thread, Locked In, Key-Locked, Heavy Duty, CRES A286, .250-20UNJC-3B internal thread with internal thread lock feature.

8. Material marking: CRES 303 or 303SE has no identifying mark.  
CRES A286 shall be identified on top of insert by one (1) line or dash mark.  
Alloy steel 4140 or 8740 shall be identified on top of insert by two (2) parallel lines or dash marks.
9. Inserts with internal thread size .250 and smaller shall be supplied with two (2) locking keys spaced 180° apart.  
Inserts with internal thread size .3125 and greater shall be supplied with four (4) locking keys spaced 90° apart.
10. Inserts shall be free of all hanging burrs and slivers which might become dislodged under usage.
11. Source identification mark: Source identification mark shall be in accordance with MIL-I-45914.
12. All dimensions are after cadmium plating or surface treatment and prior to the addition of the lubrication.
13. Fillets are R .015 maximum.

MS51831G  
w/AMENDMENT 1

Notes:

1. All dimensions are in inches.
2. Installation of inserts shall be in accordance with MS51835.
3. Distance to center of internal thread lock.
4. In the event of a conflict between the text of this standard and the references cited herein, the text of this standard shall take precedence.
5. SAE AS5272 Type I lubricant is technically equivalent to MIL-L-46010 Type I lubricant used in previous revisions.
6. MIL-PRF-46010 lubricant is lead (Pb) free and is not technically equivalent to MIL-L-46010 Type I lubricant used in previous revisions. Use of MIL-PRF-46010 in aerospace applications must first be validated.
7. Amendment notations. The margins of this specification are marked with vertical lines to indicate modifications generated by this amendment. This was done as a convenience only and the Government assumes no liability whatsoever for any inaccuracies in these notations. Bidders and contractors are cautioned to evaluate the requirements of this document based on the entire content irrespective of the marginal notations.

MILITARY INTEREST

Custodians:

Army - AR  
Navy - AS  
Air Force - 99

Preparing activity:

DLA - IS  
(Project 5325-2012-021)

Review activities:

Army – AT, AV, GL  
Navy – MC, SH  
Air Force - 71

NOTE: The activities listed above were interested in this document as of the date of this document. Since organizations and responsibilities can change, you should verify the currency of the information above using the ASSIST Online database at <https://assist.dla.mil>.