

INCH-POUND

MS51505B  
14 December 2015  
SUPERSEDING  
MS51505A  
17 January 1979

DETAIL SPECIFICATION SHEET

ELBOW, TUBE, 90 DEGREE  
37 DEGREE FLARED

This specification is approved for use by all Departments and Agencies of the Department of Defense.

Inactive for new design after 17 August 1999. For new design, use SAE-J514.

The requirements for acquiring the product described herein shall consist of this specification sheet and MIL-DTL-18866.

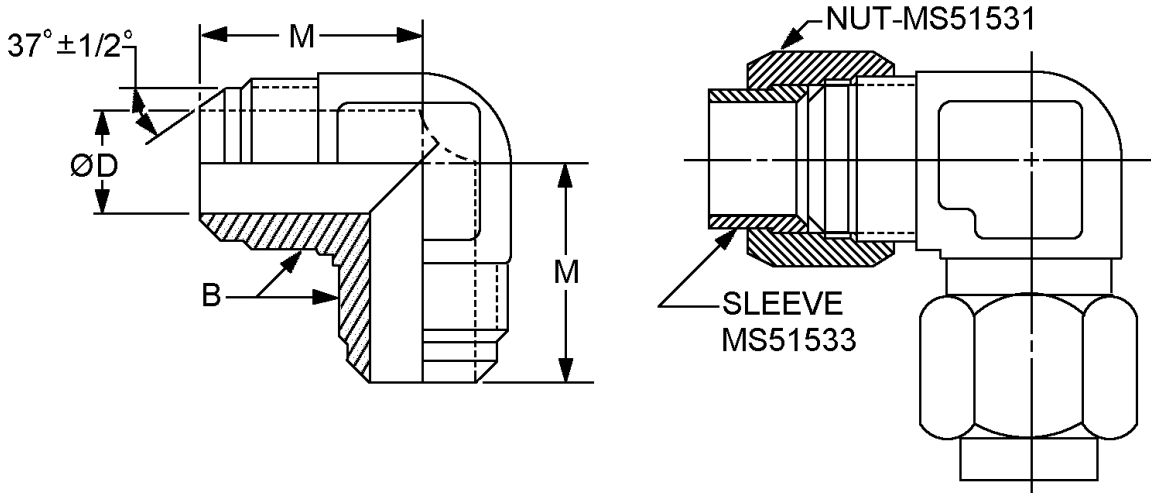

FIGURE 1. Elbow tube 90°.



## MS51505B

Suffix designator		Tube OD nom.	B Straight thread	D diameter		M inches (mm) ±.030 (.76)
Assembly (see note 4)	Body			Basic inches (mm)	Tolerance inches (mm)	
A2	B2	.1250 (3.175)	.3125-24 UNF-2A	.062 (1.57)	±.003 (0.08)	.770 (19.56)
A3	B3	.1875 (4.763)	.3750-24 UNF-2A	.125 (3.18)		.830 (21.08)
A4	B4	.2500 (6.350)	.4375-20 UNF-2A	.172 (4.37)		.890 (22.61)
A5	B5	.3125 (7.936)	.5000-20 UNF-2A	.234 (5.94)		.950 (24.13)
A6	B6	.3750 (9.525)	.5625-18 UNF-2A	.297 (7.54)	±.004 (0.10)	1.060 (26.92)
A8	B8	.5000 (12.700)	.7500-16 UNF-2A	.391 (9.93)		1.250 (31.75)
A10	B10	.6250 (15.875)	.8750-14 UNF-2A	.484 (12.29)		1.450 (36.83)
A12	B12	.7500 (19.050)	1.0625-12 UN-2A	.609 (15.47)	±.005 (0.13)	1.660 (42.16)
A14	B14	.8750 (22.225)	1.1875-12 UN-2A	.718 (18.24)		1.730 (43.94)
A16	B16	1.0000 (25.400)	1.3125-12 UN-2A	.844 (21.44)	+0.007 -.005 (+0.18 -.13)	1.810 (45.97)
A20	B20	1.2500 (31.750)	1.6250-12 UN-2A	1.078 (27.38)	+0.008 -.005 (+0.20 -.13)	2.060 (52.32)
A24	B24	1.5000 (38.100)	1.8750-12 UN-2A	1.312 (33.32)		2.330 (59.18)
A32	B32	2.0000 (50.800)	2.500-12 UN-2A	1.781 (45.24)	+0.010 -.005 (+0.25 -.013)	3.060 (77.72)

## NOTES:

1. Dimensions are in inches.
2. Metric equivalents are given for information only.
3. Break all sharp edges and remove all burrs and slivers.
4. Assemblies are only furnished to this specification (body, nut, and sleeve). Bodies are not to be stocked stored or issued.
5. Dimensions and tolerances not shown shall be in accordance with SAE-J514 for 37° flared fittings.
6. The drawing is for identification purposes only and is not intended to restrict designs and shapes not dimensioned.

FIGURE 1. Elbow tube 90° - Continued.

## REQUIREMENTS:

Fittings shall be as specified on accordance with figure 1 and in tables I and II.

Components of the assemblies shall be of the same material and finish.

Materials shall be in accordance with MIL-DTL-18866 and table I.

## MS51505B

TABLE I. Materials.

Material	Form	Specification	Alloy
Carbon steel	Bar	SAE-J403	1110, 1120, 1140, 1213, 1215, or 12L14
	Forgings		
Chrome-molybdenum steel	Bars	SAE-AMS6370	Alloy 4130
	Forgings	SAE-AMS6382	
		SAE-AMS6370	
Corrosion resistant steel	Bars and forgings	ASTM A276/A276M	304, 316, or 321
		ASTM A564/A564M	XM-12 (15-5 PH) UNS S15500 or 603 (17-4 PH) UNS S17400
		SAE-AMS5639	SAE 30304; UNS S30400
		SAE-AMS5645	SAE 30321; UNS S32100
		SAE-AMS5647	304L; UNS S30403
		SAE-AMS5643	17-4PH
		SAE-AMS5743	AM-355
	Bar	ASTM A582/A582M	UNS S30300
Nickel-copper alloy	Bar	ASTM B164 QQ-N-281	UNS N04400
High-chromium nickel alloy	Bar	ASTM B166	UNS N06690
	Forgings	ASTM B564	
Titanium <u>1/</u>	Bars	SAE-AMS4928	6Al-4V annealed
	Forgings		

1/ Titanium shall not be used in oxygen systems.

Finish. Finishes shall be as specified in table II. All platings shall be capable of meeting a minimum of 96 hours salt spray test in accordance with ASTM B117. The fittings shall show no evidence of corrosion after 96 hours of salt spray. Fluid passages, other openings and internal threads shall not be subject to the plating thickness requirement and may have bare areas provided they are protected with a light film of oil.

## MS51505B

TABLE II. Material and finish identification codes.

PIN code material/plating finish	Material	Plating finish
Blank	Steel	Cadmium plating in accordance with SAE-AMS-C-81562, type II, class 3 or SAE-AMS-QQ-P-416, type II, class 2. <u>1/</u>
CN		Cadmium plating in accordance with SAE-AMS-C-81562, type II, class 3 or SAE-AMS-QQ-P-416, type II, class 2 with NAVAIR trivalent chromium pretreatment (TCP) in accordance with MIL-DTL-81706, type II, class 1A. <u>1/</u>
E		NAVAIR TCP in accordance with MIL-DTL-81706, type II, class 1A.
F	Steel	Zinc plate (finish J, P, or R) with NAVAIR TCP in accordance with MIL-DTL-81706, type II, class 1A.
H	Steel	Zinc/Aluminum in accordance with ASTM F1136/F1136M, grade 3, NC.
J	Steel	Zinc-nickel in accordance with SAE-AMS2417, type 2, grade B.
M	Nickel-copper alloy UNS N04400	No additional finish.
N	High-chromium nickel alloy UNS N06690	No additional finish.
P	Steel	Zinc phosphate finish in accordance MIL-DTL-16232 type Z, class1.
R	Steel	Zinc plating in accordance with ASTM B633; type VI, Fe/Zn 5. <u>2/</u>
S	Corrosion resistant steel	No additional finish. Passivation in accordance with SAE-AMS2700, method 1, type 6 or 7.
T	Titanium	Anodize in accordance with SAE-AMS2488 type 2. <u>3/</u>
TF	Titanium	Fluoride phosphate in accordance with SAE-AMS2486. <u>3/</u>
Z	Steel	Zinc plating in accordance with ASTM B633; type II or III, Fe/Zn 5, or ASTM B695, type II, class 5. <u>4/</u>
ZN	Steel	Zinc plating in accordance with ASTM B633; type II or III, Fe/Zn 5, or ASTM B695, type II, class 5 with NAVAIR TCP in accordance with MIL-DTL-81706, type II, class 1A. <u>4/</u>

1/ Embrittlement test need not be run. Cadmium shall not be used in oxygen or potable water systems.

2/ Hexavalent chromium free.

3/ A pretreatment, a modification of the fluoride treatment, or a post treatment shall be applied so the final color of the fittings shall be similar to FED-STD-595 colors 36076 through 36293.

4/ Not for use in aircraft.

## MS51505B

Trivalent wrenchability.

When the finish has been damaged due to poor wrenchability, the surface of the connector shall be touched up using the brush plating process below. The term "trivalent wrenchability" is used to evaluate the ability of the finish to withstand abrasion from an excessive amount of wrenching.

- a. Brush plating of hard chromium by electrodeposition shall be in accordance with SAE-AMS-2451/5.
- b. Brush plating of medium-hardness, low stress nickel by electrodeposition shall be in accordance with SAE-AMS-2451/9.
- c. Brush plating of NAVAIR TCP shall be in accordance with MIL-DTL-81706, type II, class 1A, material form 1 through 6, application method B. Example of a PIN: M817062A6B.

Maximum operating pressure. Maximum operating pressure shall be in accordance with SAE-J514.

PIN: The PIN consists of the letters "MS", the specification number, a letter and number for elbow size, and a letter for material finish designator.

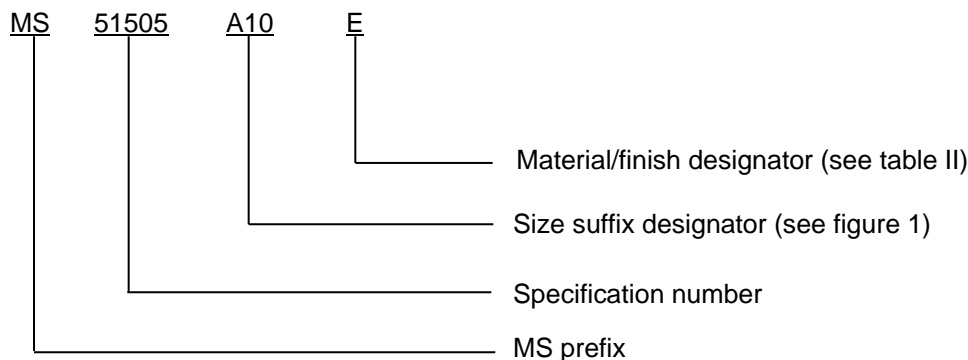

PIN example: MS51505A10E indicates an elbow 90°, .6250 inch (15.875 mm), steel with NAVAIR TCP.

Cadmium is not recommended. To the users of this document, it is recommended that the use of carbon steel material with cadmium plating be used only when other materials and finishes specified in this document cannot meet performance requirements.

Order of precedence. Unless otherwise noted herein or in the contract, in the event of a conflict between the text of this document and the references cited herein, the text of this document takes precedence. Nothing in this document, however, supersedes applicable laws and regulations unless a specific exemption has been obtained.

Referenced documents shall be of the issue in effect on date of invitations for bid.

Table III provides a detailed cross-reference of inactive MS51505 PIN's and for new design SAE-J514 PIN's. MS51505 parts have straight threads in accordance with ASME B1.1 the SAE parts have straight threads in accordance with SAE-J425. Users are cautioned to evaluate replacement parts for their particular application.

**CAUTION:** The superseding information is valid as of the date of this specification and may be superseded by subsequent revisions of the superseding document.

## MS51505B

TABLE III. MS51505 to SAE-J514 cross reference.

Inactive for new design MS51505- PIN		Tube OD	For new design SAE-J514 PIN	
Assembly	Body		Assembly	Body
MS51505A2	MS51505B2	1/8	Not available	Not available
MS51505A2CN	MS51505B2CN	1/8	Not available	Not available
MS51505A2E	MS51505B2E	1/8	Not available	Not available
MS51505A2F	MS51505B2F	1/8	Not available	Not available
MS51505A2H	MS51505B2H	1/8	Not available	Not available
MS51505A2J	MS51505B2J	1/8	Not available	Not available
MS51505A2M	MS51505B2M	1/8	J514-2-2-070201MA	J514-2-2-070201MB
MS51505A2N	MS51505B2N	1/8	J514-2-2-070201NA	J514-2-2-070201NB
MS51505A2P	MS51505B2P	1/8	J514-2-2-070201PA	J514-2-2-070201PB
MS51505A2R	MS51505B2R	1/8	Not available	Not available
MS51505A2S	MS51505B2S	1/8	J514-2-2-070201SA	J514-2-2-070201SB
MS51505A2T	MS51505B2T	1/8	J514-2-2-070201TA	J514-2-2-070201TB
MS51505A2TF	MS51505B2TF	1/8	Not available	Not available
MS51505A2Z	MS51505B2Z	1/8	J514-2-2-070201ZA	J514-2-2-070201ZB
MS51505A2ZN	MS51505B2ZN	1/8	Not available	Not available
MS51505A3	MS51505B3	3/16	Not available	Not available
MS51505A3CN	MS51505B3CN	3/16	Not available	Not available
MS51505A3E	MS51505B3E	3/16	Not available	Not available
MS51505A3F	MS51505B3F	3/16	Not available	Not available
MS51505A3H	MS51505B3H	3/16	Not available	Not available
MS51505A3J	MS51505B3J	3/16	Not available	Not available
MS51505A3M	MS51505B3M	3/16	J514-3-3-070201MA	J514-3-3-070201MB
MS51505A3N	MS51505B3N	3/16	J514-3-3-070201NA	J514-3-3-070201NB
MS51505A3P	MS51505B3P	3/16	J514-3-3-070201PA	J514-3-3-070201PB
MS51505A3R	MS51505B3R	3/16	Not available	Not available
MS51505A3S	MS51505B3S	3/16	J514-3-3-070201SA	J514-3-3-070201SB
MS51505A3T	MS51505B3T	3/16	J514-3-3-070201TA	J514-3-3-070201TB
MS51505A3TF	MS51505B3TF	3/16	Not available	Not available
MS51505A3Z	MS51505B3Z	3/16	J514-3-3-070201ZA	J514-3-3-070201ZB
MS51505A3ZN	MS51505B3ZN	3/16	Not available	Not available
MS51505A4	MS51505B4	1/4	Not available	Not available
MS51505A4CN	MS51505B4CN	1/4	Not available	Not available
MS51505A4E	MS51505B4E	1/4	Not available	Not available
MS51505A4F	MS51505B4F	1/4	Not available	Not available
MS51505A4H	MS51505B4H	1/4	Not available	Not available
MS51505A4J	MS51505B4J	1/4	Not available	Not available
MS51505A4M	MS51505B4M	1/4	J514-4-4-070201MA	J514-4-4-070201MB
MS51505A4N	MS51505B4N	1/4	J514-4-4-070201NA	J514-4-4-070201NB
MS51505A4P	MS51505B4P	1/4	J514-4-4-070201PA	J514-4-4-070201PB
MS51505A4R	MS51505B4R	1/4	Not available	Not available
MS51505A4S	MS51505B4S	1/4	J514-4-4-070201SA	J514-4-4-070201SB
MS51505A4T	MS51505B4T	1/4	J514-4-4-070201TA	J514-4-4-070201TB
MS51505A4TF	MS51505B4TF	1/4	Not available	Not available
MS51505A4Z	MS51505B4Z	1/4	J514-4-4-070201SA	J514-4-4-070201ZB
MS51505A4ZN	MS51505B4ZN	1/4	Not available	Not available

## MS51505B

TABLE III. MS51505 to SAE-J514 cross reference - Continued.

Inactive for new design MS51505- PIN		Tube OD	For new design SAE-J514 PIN	
Assembly	Body		Assembly	Body
MS51505A5	MS51505B5	5/16	Not available	Not available
MS51505A5CN	MS51505B5CN	5/16	Not available	Not available
MS51505A5E	MS51505B5E	5/16	Not available	Not available
MS51505A5F	MS51505B5F	5/16	Not available	Not available
MS51505A5H	MS51505B5H	5/16	Not available	Not available
MS51505A5J	MS51505B5J	5/16	Not available	Not available
MS51505A5M	MS51505B5M	5/16	J514-5-5-070201MA	J514-5-5-070201MB
MS51505A5N	MS51505B5N	5/16	J514-5-5-070201NA	J514-5-5-070201NB
MS51505A5P	MS51505B5P	5/16	J514-5-5-070201PA	J514-5-5-070201PB
MS51505A5R	MS51505B5R	5/16	Not available	Not available
MS51505A5S	MS51505B5S	5/16	J514-5-5-070201SA	J514-5-5-070201SB
MS51505A5T	MS51505B5T	5/16	J514-5-5-070201TA	J514-5-5-070201TB
MS51505A5TF	MS51505B5TF	5/16	Not available	Not available
MS51505A5Z	MS51505B5Z	5/16	J514-5-5-070201ZA	J514-5-5-070201ZB
MS51505A5ZN	MS51505B5ZN	5/16	Not available	Not available
MS51505A6	MS51505B6	3/8	Not available	Not available
MS51505A6CN	MS51505B6CN	3/8	Not available	Not available
MS51505A6E	MS51505B6E	3/8	Not available	Not available
MS51505A6F	MS51505B6F	3/8	Not available	Not available
MS51505A6H	MS51505B6H	3/8	Not available	Not available
MS51505A6J	MS51505B6J	3/8	Not available	Not available
MS51505A6M	MS51505B6M	3/8	J514-6-6-070201MA	J514-6-6-070201MB
MS51505A6N	MS51505B6N	3/8	J514-6-6-070201NA	J514-6-6-070201NB
MS51505A6P	MS51505B6P	3/8	J514-6-6-070201PA	J514-6-6-070201PB
MS51505A6R	MS51505B6R	3/8	Not available	Not available
MS51505A6S	MS51505B6S	3/8	J514-6-6-070201SA	J514-6-6-070201SB
MS51505A6T	MS51505B6T	3/8	J514-6-6-070201TA	J514-6-6-070201TB
MS51505A6TF	MS51505B6TF	3/8	Not available	Not available
MS51505A6Z	MS51505B6Z	3/8	J514-6-6-070201ZA	J514-6-6-070201ZB
MS51505A6ZN	MS51505B6ZN	3/8	Not available	Not available
MS51505A8	MS51505B8	1/2	Not available	Not available
MS51505A8CN	MS51505B8CN	1/2	Not available	Not available
MS51505A8E	MS51505B8E	1/2	Not available	Not available
MS51505A8G	MS51505B8G	1/2	Not available	Not available
MS51505A8H	MS51505B8H	1/2	Not available	Not available
MS51505A8J	MS51505B8J	1/2	Not available	Not available
MS51505A8M	MS51505B8M	1/2	J514-8-8-070201MA	J514-8-8-070201MB
MS51505A8N	MS51505B8N	1/2	J514-8-8-070201NA	J514-8-8-070201NB
MS51505A8P	MS51505B8P	1/2	J514-8-8-070201PA	J514-8-8-070201PB
MS51505A8R	MS51505B8R	1/2	Not available	Not available
MS51505A8S	MS51505B8S	1/2	J514-8-8-070201SA	J514-8-8-070201SB
MS51505A8T	MS51505B8T	1/2	J514-8-8-070201TA	J514-8-8-070201TB
MS51505A8TF	MS51505B8TF	1/2	Not available	Not available
MS51505A8Z	MS51505B8Z	1/2	J514-8-8-070201ZA	J514-8-8-070201ZB
MS51505A8ZN	MS51505B8ZN	1/2	Not available	Not available

## MS51505B

TABLE III. MS51505 to SAE-J514 cross reference - Continued.

Inactive for new design MS51505- PIN		Tube OD	For new design SAE-J514 PIN	
Assembly	Body		Assembly	Body
MS51505A10	MS51505B10	5/8	Not available	Not available
MS51505A10CN	MS51505B10CN	5/8	Not available	Not available
MS51505A10E	MS51505B10E	5/8	Not available	Not available
MS51505A10F	MS51505B10F	5/8	Not available	Not available
MS51505A10H	MS51505B10H	5/8	Not available	Not available
MS51505A10J	MS51505B10J	5/8	Not available	Not available
MS51505A10M	MS51505B10M	5/8	J514-10-10-070201MA	J514-10-10-070201MB
MS51505A10N	MS51505B10N	5/8	J514-10-10-070201NA	J514-10-10-070201NB
MS51505A10P	MS51505B10P	5/8	J514-10-10-070201PA	J514-10-10-070201PB
MS51505A10R	MS51505B10R	5/8	Not available	Not available
MS51505A10S	MS51505B10S	5/8	J514-10-10-070201SA	J514-10-10-070201SB
MS51505A10T	MS51505B10T	5/8	J514-10-10-070201TA	J514-10-10-070201TB
MS51505A10TF	MS51505B10TF	5/8	Not available	Not available
MS51505A10Z	MS51505B10Z	5/8	J514-10-10-070201ZA	J514-10-10-070201ZB
MS51505A10ZN	MS51505B10ZN	5/8	Not available	Not available
MS51505A12	MS51505B12	3/4	Not available	Not available
MS51505A12CN	MS51505B12XN	3/4	Not available	Not available
MS51505A12E	MS51505B12E	3/4	Not available	Not available
MS51505A12F	MS51505B12F	3/4	Not available	Not available
MS51505A12H	MS51505B12H	3/4	Not available	Not available
MS51505A12J	MS51505B12J	3/4	Not available	Not available
MS51505A12M	MS51505B12M	3/4	J514-12-12-070201MA	J514-12-12-070201MB
MS51505A12N	MS51505B12N	3/4	J514-12-12-070201NA	J514-12-12-070201NB
MS51505A12P	MS51505B12P	3/4	J514-12-12-070201PA	J514-12-12-070201PB
MS51505A12R	MS51505B12R	3/4	Not available	Not available
MS51505A12S	MS51505B12S	3/4	J514-12-12-070201SA	J514-12-12-070201SB
MS51505A12T	MS51505B12T	3/4	J514-12-12-070201TA	J514-12-12-070201TB
MS51505A12TF	MS51505B12TF	3/4	Not available	Not available
MS51505A12Z	MS51505B12Z	3/4	J514-12-12-070201ZA	J514-12-12-070201ZB
MS51505A12ZN	MS51505B12ZN	3/4	Not available	Not available
MS51505A14	MS51505B14	7/8	Not available	Not available
MS51505A14CN	MS51505B14CN	7/8	Not available	Not available
MS51505A14E	MS51505B14E	7/8	Not available	Not available
MS51505A14F	MS51505B14F	7/8	Not available	Not available
MS51505A14H	MS51505B14H	7/8	Not available	Not available
MS51505A14J	MS51505B14J	7/8	Not available	Not available
MS51505A14M	MS51505B14M	7/8	J514-14-14-070201MA	J514-14-14-070201MB
MS51505A14N	MS51505B14N	7/8	J514-14-14-070201NA	J514-14-14-070201NB
MS51505A14P	MS51505B14P	7/8	J514-14-14-070201PA	J514-14-14-070201PB
MS51505A14R	MS51505B14R	7/8	Not available	Not available
MS51505A14S	MS51505B14S	7/8	J514-14-14-070201SA	J514-14-14-070201SB
MS51505A14T	MS51505B14T	7/8	J514-14-14-070201TA	J514-14-14-070201TB
MS51505A14TF	MS51505B14TF	7/8	Not available	Not available
MS51505A14Z	MS51505B14Z	7/8	J514-14-14-070201ZA	J514-14-14-070201ZB
MS51505A14ZN	MS51505B14ZN	7/8	Not available	Not available



## MS51505B

TABLE III. MS51505 to SAE-J514 cross reference - Continued.

Inactive for new design MS51505- PIN		Tube OD	For new design SAE-J514 PIN	
Assembly	Body		Assembly	Body
MS51505A16	MS51505B16	1	Not available	Not available
MS51505A16CN	MS51505B16CN	1	Not available	Not available
MS51505A16E	MS51505B16E	1	Not available	Not available
MS51505A16F	MS51505B16F	1	Not available	Not available
MS51505A16H	MS51505B16H	1	Not available	Not available
MS51505A16J	MS51505B16J	1	Not available	Not available
MS51505A16M	MS51505B16M	1	J514-16-16-070201MA	J514-16-16-070201MB
MS51505A16N	MS51505B16N	1	J514-16-16-070201NA	J514-16-16-070201NB
MS51505A16P	MS51505B16P	1	J514-16-16-070201PA	J514-16-16-070201PB
MS51505A16R	MS51505B16R	1	Not available	Not available
MS51505A16S	MS51505B16S	1	J514-16-16-070201SA	J514-16-16-070201SB
MS51505A16T	MS51505B16T	1	J514-16-16-070201TA	J514-16-16-070201TB
MS51505A16TF	MS51505B16TF	1	Not available	Not available
MS51505A16Z	MS51505B16Z	1	J514-16-16-070201ZA	J514-16-16-070201ZB
MS51505A16ZN	MS51505B16ZN	1	Not available	Not available
MS51505A20	MS51505B20	1 1/4	Not available	Not available
MS51505A20CN	MS51505B20CN	1 1/4	Not available	Not available
MS51505A20E	MS51505B20E	1 1/4	Not available	Not available
MS51505A20F	MS51505B20F	1 1/4	Not available	Not available
MS51505A20H	MS51505B20H	1 1/4	Not available	Not available
MS51505A20J	MS51505B20J	1 1/4	Not available	Not available
MS51505A20M	MS51505B20M	1 1/4	J514-20-20-070201MA	J514-20-20-070201MB
MS51505A20N	MS51505B20N	1 1/4	J514-20-20-070201NA	J514-20-20-070201NB
MS51505A20P	MS51505B20P	1 1/4	J514-20-20-070201PA	J514-20-20-070201PB
MS51505A20R	MS51505B20R	1 1/4	Not available	Not available
MS51505A20S	MS51505B20S	1 1/4	J514-20-20-070201SA	J514-20-20-070201SB
MS51505A20T	MS51505B20T	1 1/4	J514-20-20-070201TA	J514-20-20-070201TB
MS51505A20TF	MS51505B20TF	1 1/4	Not available	Not available
MS51505A20Z	MS51505B20Z	1 1/4	J514-20-20-070201ZA	J514-20-20-070201ZB
MS51505A20ZN	MS51505B20ZN	1 1/4	Not available	Not available
MS51505A24	MS51505B24	1 1/2	Not available	Not available
MS51505A24CN	MS51505B24CN	1 1/2	Not available	Not available
MS51505A24E	MS51505B24E	1 1/2	Not available	Not available
MS51505A24F	MS51505B24F	1 1/2	Not available	Not available
MS51505A24G	MS51505B24G	1 1/2	Not available	Not available
MS51505A24H	MS51505B24H	1 1/2	Not available	Not available
MS51505A24M	MS51505B24M	1 1/2	J514-24-24-070201MA	J514-24-24-070201MB
MS51505A24N	MS51505B24N	1 1/2	J514-24-24-070201NA	J514-24-24-070201NB
MS51505A24P	MS51505B24P	1 1/2	J514-24-24-070201PA	J514-24-24-070201PB
MS51505A24R	MS51505B24R	1 1/2	Not available	Not available
MS51505A24S	MS51505B24S	1 1/2	J514-24-24-070201SA	J514-24-24-070201SB
MS51505A24T	MS51505B24T	1 1/2	J514-24-24-070201TA	J514-24-24-070201TB
MS51505A24TF	MS51505B24TF	1 1/2	Not available	Not available
MS51505A24Z	MS51505B24Z	1 1/2	J514-24-24-070201ZA	J514-24-24-070201ZB
MS51505A24ZN	MS51505B24ZN	1 1/2	Not available	Not available

## MS51505B

TABLE III. MS51505 to SAE-J514 cross reference - Continued.

Inactive for new design MS51505- PIN		Tube OD	For new design SAE-J514 PIN	
Assembly	Body		Assembly	Body
MS51505A32	MS51505B32	2	Not available	Not available
MS51505A32CN	MS51505B32CN	2	Not available	Not available
MS51505A32E	MS51505B32E	2	Not available	Not available
MS51505A32F	MS51505B32F	2	Not available	Not available
MS51505A32H	MS51505B32H	2	Not available	Not available
MS51505A32J	MS51505B32J	2	Not available	Not available
MS51505A32M	MS51505B32M	2	J514-32-32-070201MA	J514-32-32-070201MB
MS51505A32N	MS51505B32N	2	J514-32-32-070201NA	J514-32-32-070201NB
MS51505A32P	MS51505B32P	2	J514-32-32-070201PA	J514-32-32-070201PB
MS51505A32R	MS51505B32R	2	Not available	Not available
MS51505A32S	MS51505B32S	2	J514-32-32-070201SA	J514-32-32-070201SB
MS51505A32T	MS51505B32T	2	J514-32-32-070201TA	J514-32-32-070201TB
MS51505A32TF	MS51505B32TF	2	Not available	Not available
MS51505A32Z	MS51505B32Z	2	J514-32-32-070201ZA	J514-32-32-070201ZB
MS51505A32ZN	MS51505B32ZN	2	Not available	Not available

Changes from previous issue. Marginal notations are not used in this revision to identify changes with respect to the previous issue, due to the extent of the changes.

Referenced documents. In addition to MIL-DTL-18866, this document references the following:

FED-STD-595/36076	FED-STD-595/36293	ASTM B564	SAE-AMS5639
FED-STD-595/36081	MIL-DTL-16232	ASTM B633	SAE-AMS5643
FED-STD-595/36099	MIL-DTL-81706	ASTM B695	SAE-AMS5645
FED-STD-595/36118	MS51531	ASTM F1136/F1136M	SAE-AMS5647
FED-STD-595/36134	MS51533	SAE-AMS-C-81562	SAE-AMS5743
FED-STD-595/36152	QQ-N-281	SAE-AMS-QQ-P-416	SAE-AMS6370
FED-STD-595/36170	ASME B1.1	SAE-AMS2417	SAE-AMS6382
FED-STD-595/36173	ASTM A276/A276M	SAE-AMS2451/5	SAE-J403
FED-STD-595/36176	ASTM A564/A564M	SAE-AMS2451/9	SAE-J425
FED-STD-595/36231	ASTM A582/A582M	SAE-AMS2486	SAE-J514
FED-STD-595/36251	ASTM B117	SAE-AMS2488	
FED-STD-595/36270	ASTM B164	SAE-AMS2700	
FED-STD-595/36280	ASTM B166	SAE-AMS4928	

MS51505B

CONCLUDING MATERIAL

Custodians:

Army - AR  
Navy - OS  
Air Force - 99  
DLA - CC

Preparing activity:  
DLA - CC

(Project 4730-2016-001)

Review activities:

Army - AT  
Navy - MC  
Air Force - 71

NOTE: The activities listed above were interested in this document as of the date of this document. Since organizations and responsibilities can change, you should verify the currency of the information above using the ASSIST Online database at <https://assist.dla.mil>.