

FED. SUP CLASS  
2590

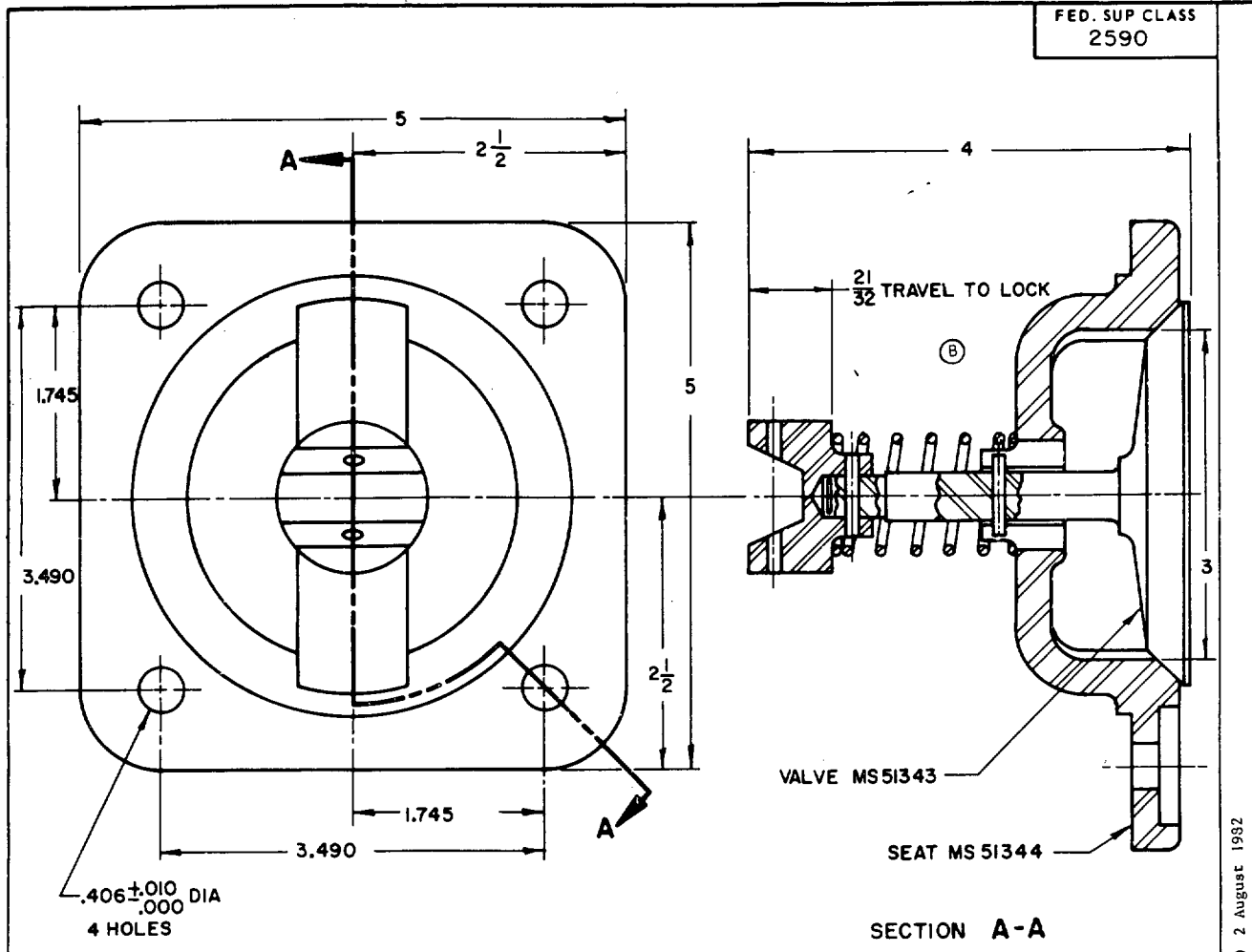

(A)

NOTES:

1. FOR MS51345-1, STEEL, USE SEAT MS51344-1 AND VALVE MS51343-1.
2. FOR MS51345-2, ALUMINUM, USE SEAT MS51344-2 AND VALVE MS51343-2.
3. DIMENSIONS SHOWN ARE FOR ENGINEERING REFERENCE ONLY.
4. REFERENCED DOCUMENTS SHALL BE OF THE ISSUE IN EFFECT ON DATE OF INVITATION FOR BID.
5. MARKING SHALL CONSIST OF THE MS PART NUMBER AND MANUFACTURER'S IDENTIFICATION IN ACCORDANCE WITH MIL-STD-130.

This standard has been approved by the U. S. Army Tank-Automotive Command, Department of the Army, and is mandatory for use by that activity. All other military activities are required to employ this standard where suitable.

MS PART NO.	MATERIAL
MS 51345-1	STEEL
MS 51345-2	ALUMINUM

P.A. ARMY-AT Other Cust	TITLE <b>VALVE ASSEMBLY, POPPET, HULL DRAIN-VEHICULAR, 3 INCH</b>	<b>MILITARY STANDARD</b>
PROCUREMENT SPECIFICATION NONE	SUPERSEDES:	<b>MS 51345 (AT)</b>
		SHEET 1 OF 1

APPROVED 9 JANUARY 1961, REVISED (A) 18 OCTOBER 1966 Revised (B) 2 August 1992