

The requirements for acquiring the product, service, or construction shall consist of this specification sheet and the issue of the following specification listed in that issue of the DoD ISS spec in the solicitation: MIL-C-45300

This specification is approved for use by all departments and Agencies of the Department of Defense.

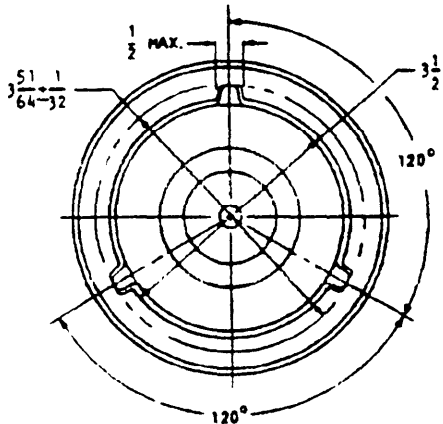
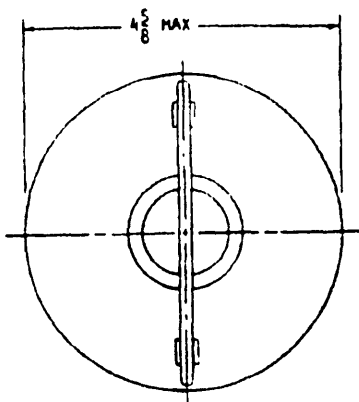

NOTES:

1. THIS CAP IS OF PROCUREMENT SPECIFICATION MIL-C-45300.
2. THIS CAP IS TO BE USED WITH NECKS SHOWN ON MS35644.
3. MATERIAL: RETAINER: STEEL 1065, 1075, AND 1085 OF QQ-S-700. AFTER FORMING, RETAINER SHALL BE ANNEALED AND TEMPERED TO ROCKWELL 40-55 C. THE CHAIN SHALL CONFORM TO RR-C-271, TYPE II, CLASS 6.
4. PROTECTIVE COATING: INTERIOR PARTS SHALL BE ZINC PLATED PER ASTM B633 TYPE II, CLASS 2. THE COVER AND OTHER EXTERIOR PARTS SHALL BE PHOSPHATE COATED PER DOD-P-16232, TYPE Z, CLASS I.
5. UNLESS OTHERWISE SPECIFIED, DIMENSIONS ARE IN INCHES. TOLERANCES ARE $\pm 1/64$ FOR FRACTIONS, $\pm .010$ FOR DECIMALS, AND $\pm 1^\circ$ FOR ANGLES.
6. IN THE EVENT OF A CONFLICT BETWEEN THE TEXT OF THIS STANDARD AND THE REFERENCES CITED HEREIN, THE TEXT OF THIS STANDARD SHALL TAKE PRECEDENCE.
7. REFERENCED DOCUMENTS SHALL BE OF THE ISSUE IN EFFECT ON DATE OF INVITATION FOR BIDS.
8. THIS STANDARD IS NOT INTENDED TO LIMIT CONSTRUCTION TO FEATURES OTHER THAN SHOWN HEREON BY DIMENSIONS, NOTATIONS AND REFERENCED DOCUMENTS.
9. MARKING SHALL CONSIST OF THE MS PART NUMBER AND MANUFACTURER'S IDENTIFICATION IN ACCORDANCE WITH MIL-STD-130.

(E)

(E) DENOTES CHANGE

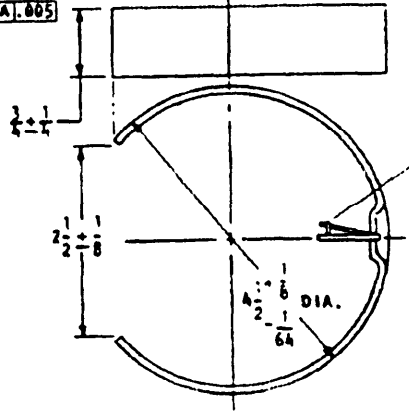
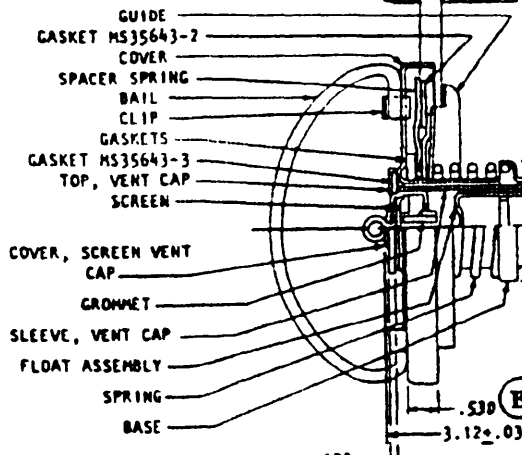

MS PART NO.	FORMER PART NO.
MS51300-1	7984056

PREPARING ACTIVITY: AT CUSTODIANS: ARMY AT NAVY AIR FORCE- 99 DLA- REVIEW: ME, 82, CC USFP: MI, MC PROJECT NUMBER: 2910-0185	MILITARY SPECIFICATION SHEET TITLE: CAP, FUEL TANK: COMBAT VEHICLE, SPILL-PROOF	SPECIFICATION SHEET NUMBER: MS51300E(AT) 13 JUNE 1990 SUPERSEDING: MS51300D 30 SEPTEMBER 1987 AMSC-N/A FSC-2910
---	--	--