

FED. SUP CLASS
2910

USER ACTIVITIES. DLA-CS

REVIEWER ACTIVITIES AF-99

This military standard is approved for use by the US Army Tank-Automotive Command, Department of the Army, and is available for use by all Departments and Agencies of the Department of Defense.

DISTRIBUTION STATEMENT A. Approved for public release; distribution is unlimited. AMSC W/A

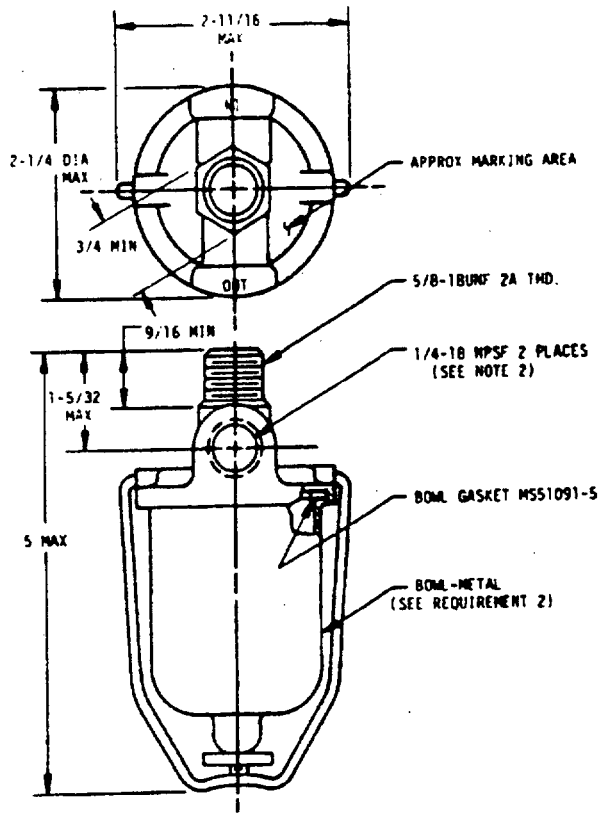

REQUIREMENTS:

1. TYPE 1, CLASS 2, FUEL FILTER ASSEMBLY WITH ELEMENT, 2) G.P.H., COARSE FILTRATION, OF PROCUREMENT SPECIFICATION.
2. OPTIONAL BOWL MATERIALS:
 - (B) A. BRASS, ANNEALED, QQ-B-613, COPPER ALLOY NO. 240, 260, OR 268.
 - B. STEEL, QQ-S-636, CONDITION 3 TO 5.
3. STEEL BOWL AND COVER TO BE TREATED WITH CORROSION INHIBITOR PER TYPE 1, CLASS 2 OF MIL-T-12879.
4. THREADS SHALL BE IN ACCORDANCE WITH FED-STD-M28.
5. MARKING SHALL CONSIST OF THE MS PART NUMBER AND MANUFACTURER'S IDENTIFICATION IN ACCORDANCE WITH MIL-STD-130.

NOTES:

1. DIMENSIONS ARE IN INCHES AND ARE FOR ENGINEERING REFERENCE ONLY.
2. FOR 1/8-27 NPSF APPLICATION, USE APPLICABLE REDUCER BUSHING.
3. FOR INFORMATION OTHER THAN SHOWN HEREON, SEE PROCUREMENT SPECIFICATION.
4. THIS STANDARD IS NOT INTENDED TO LIMIT CONSTRUCTION TO FEATURES OTHER THAN SHOWN HEREON BY DIMENSIONS, NOTATIONS, AND REFERENCED DOCUMENTS.
- (B) 5. IN THE EVENT OF A CONFLICT BETWEEN THE TEXT OF THIS STANDARD AND THE REFERENCES CITED HEREIN, THE TEXT OF THIS STANDARD SHALL TAKE PRECEDENCE. (SEE PARA. 5.1.16 OF MIL-STD-962)

(B) DENOTES CHANGE

MS PART NO.	FORMER PART NO.
MSS1087-1	NONE

P. A. Other Cont	ARMY-AT AF-15	INTERNATIONAL INTEREST	TITLE FILTER, FLUID, PRESSURE - AUTOMOTIVE FUEL (21 GPH)	MILITARY STANDARD MS51087
PROCUREMENT SPECIFICATION MIL-F-45356	SUPERSIDES			SHEET 1 OF 1

DD FORM 672-1 COORDINATED

PREPARED BY THE FORM AND TITLE CENTER

2910-0186

APPROVED 8 JULY 1958 REVISED (A) 23 AUGUST 1962 (B) 16 FEB 1988