

THE REQUIREMENTS FOR ACQUIRING THE PRODUCT(S) DESCRIBED HEREIN SHALL CONSIST OF THIS SPECIFICATION SHEET AND THE ISSUE OF THE FOLLOWING SPECIFICATION LISTED IN THAT ISSUE OF THE SOURCE SPECIFIED IN THE SOLICITATION F-F-351

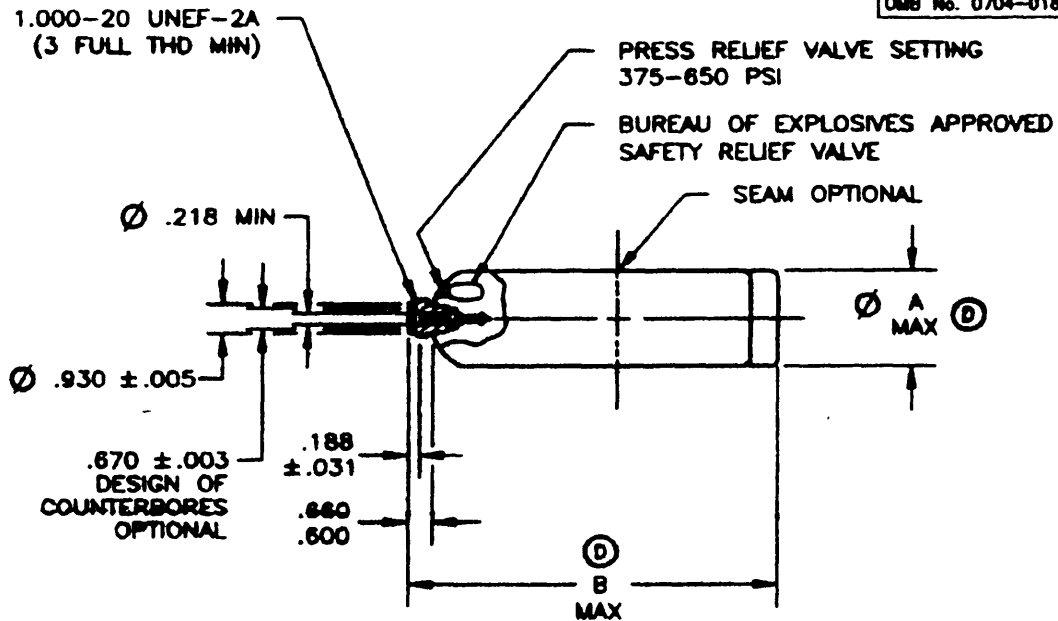

Ⓣ

DASH NO.	DIMENSIONS		CAPACITY PRIM FUEL OZ AVDP
	A	B	
-1	3.000	11.000	18
-2	4.000	7.680	21

NOTES:

1. ALL DIMENSIONS IN INCHES.
- Ⓣ 2. THREADS SHALL BE IN ACCORDANCE WITH ANSI Y14.8.
- Ⓣ 3. CYLINDER CONFORMS TO TYPE III OF PROCUREMENT SPECIFICATION.
4. CYLINDER SHALL CONFORM WITH DOT REQUIREMENTS CFR 49, PARTS 178 TO 199, SPEC. 39 OR SPEC. 4B.
5. UNLESS OTHERWISE INDICATED, COPIES OF FEDERAL AND MILITARY SPECIFICATIONS, STANDARDS, AND HANDBOOKS ARE AVAILABLE FROM THE STANDARDIZATION DOCUMENTS ORDER DESK, BUILDING 4D, 700 ROBBINS AVENUE, PHILADELPHIA, PA 19111-5094.
6. FOR DESIGN FEATURE PURPOSE, THIS STANDARD TAKES PRECEDENCE OVER PROCUREMENT DOCUMENTS REFERENCED HEREIN.
7. IN THE EVENT OF A CONFLICT BETWEEN THE TEXT OF THIS DOCUMENT AND THE REFERENCES CITED HEREIN, THE TEXT OF THIS DOCUMENT TAKES PRECEDENCE. NOTHING IN THIS DOCUMENT, HOWEVER, SUPERSEDES APPLICABLE LAWS AND REGULATIONS UNLESS A SPECIFIC EXEMPTION HAS BEEN OBTAINED.

Ⓣ ENTIRE STANDARD REDRAWN WITH CHANGES

THIS SPECIFICATION IS APPROVED FOR USE BY ALL DEPARTMENTS AND AGENCIES OF THE DEPARTMENT OF DEFENSE.

PREPARING ACTIVITY: ARMY-HE CUSTOMER: NAVY-NC	TITLE: MILITARY SPECIFICATION SHEET	SPECIFICATION SHEET NUMBER MS 392540 4 MAR 84
REWER: ARMY-HE USER: PROJECT NUMBER: 2910-0007	CYLINDER, ENGINE STARTING (ENGINE COLD-STARTING AID)	SUBSTITUTION MS 392540 11 JAN 1991
DISTRIBUTION STATEMENT A. APPROVED FOR PUBLIC RELEASE; DISTRIBUTION IS UNLIMITED.		AMSC- N/A FSC 2910
		PAGE 1 OF 1