

FED. SUP CLASS  
**4730**

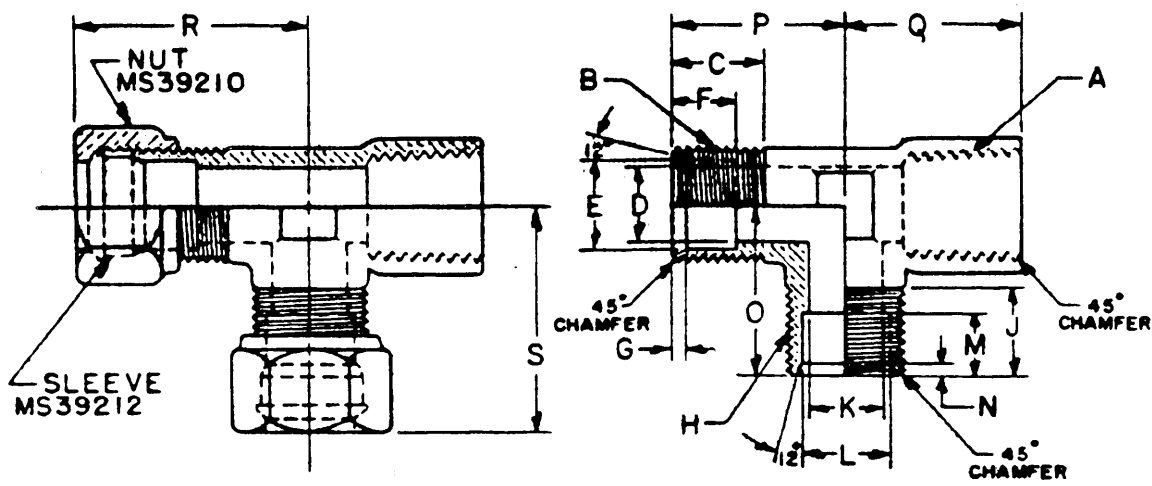

DETAIL OF BODY

| DASH NO. | TUBE O.D. |      | A PIPE THREADS NETP | B              | C THREAD LENGTH | D     | E            | F     | G     | H              | J     | K     | L            | M     | N     |
|----------|-----------|------|---------------------|----------------|-----------------|-------|--------------|-------|-------|----------------|-------|-------|--------------|-------|-------|
| 1        | 1/8       | 1/8  | 1/8                 | 5/16-24UNF-2A  | 9/32            | 3/32  | .135<br>.139 | 13/64 | 1/8   | 5/16-24UNF-2A  | 9/32  | 3/32  | .135<br>.139 | 13/64 | 1/8   |
| 2        | 3/16      | 3/16 | 1/8                 | 3/8-24UNF-2A   | 9/32            | 1/8   | .196<br>.200 | 1/4   | 5/32  | 3/8-24UNF-2A   | 9/32  | 1/8   | .196<br>.200 | 1/4   | 5/32  |
| 3        | 1/4       | 1/4  | 1/8                 | 1/2-20UNF-2A   | 13/32           | 13/64 | .261<br>.265 | 19/64 | 13/64 | 1/2-20UNF-2A   | 13/32 | 13/64 | .261<br>.265 | 19/64 | 13/64 |
| 4        | 5/16      | 5/16 | 1/8                 | 9/16-18UNF-2A  | 13/32           | 13/64 | .324<br>.328 | 19/64 | 13/64 | 9/16-18UNF-2A  | 13/32 | 13/64 | .324<br>.328 | 19/64 | 13/64 |
| 5        | 3/8       | 3/8  | 1/4                 | 5/8-18UNF-2A   | 7/16            | 9/32  | .386<br>.390 | 19/64 | 13/64 | 5/8-18UNF-2A   | 7/16  | 9/32  | .386<br>.390 | 19/64 | 13/64 |
| 6        | 1/2       | 1/2  | 3/8                 | 3/4-16UNF-2A   | 7/16            | 27/64 | .514<br>.518 | 5/16  | 13/64 | 3/4-16UNF-2A   | 7/16  | 27/64 | .514<br>.518 | 5/16  | 13/64 |
| 7        | 5/8       | 5/8  | 1/2                 | 15/16-16UN-2A  | 15/32           | 1/2   | .641<br>.645 | 11/32 | 15/64 | 15/16-16UN-2A  | 15/32 | 1/2   | .641<br>.645 | 11/32 | 15/64 |
| 8        | 3/4       | 3/4  | 3/4                 | 1 1/16-16UN-2A | 15/32           | 21/32 | .766<br>.770 | 11/32 | 13/64 | 1 1/16-16UN-2A | 15/32 | 21/32 | .766<br>.770 | 11/32 | 13/64 |

| DASH NO. | O      | P      | Q      | R       | S       |
|----------|--------|--------|--------|---------|---------|
| 1        | 23/32  | 23/32  | 5/8    | 1 1/32  | 1 1/32  |
| 2        | 23/32  | 23/32  | 5/8    | 1 1/16  | 1 1/16  |
| 3        | 25/32  | 25/32  | 11/16  | 1 3/16  | 1 3/16  |
| 4        | 13/16  | 13/16  | 11/16  | 1 3/16  | 1 3/16  |
| 5        | 1      | 1      | 7/8    | 1 7/16  | 1 7/16  |
| 6        | 1 3/16 | 1 3/16 | 15/16  | 1 23/32 | 1 23/32 |
| 7        | 1 5/16 | 1 5/16 | 1 3/16 | 1 27/32 | 1 27/32 |
| 8        | 1 1/2  | 1 1/2  | 1 3/8  | 2 3/32  | 2 3/32  |

**Ⓢ** **INACTIVE** FOR NEW DESIGN. USE FOR MAINTENANCE PURPOSES ONLY. FOR NEW DESIGN USE MS51822.

This military standard is approved for use by the US Army Tank-Automotive Command, Department of the Army, and is available for use by all Departments and Agencies of the Department of Defense.

|                                   |  |   |
|-----------------------------------|--|---|
| P.A. ARMY-AT<br>Other Cost        | TITLE<br>THIS, PIPE TO TUBE - SAFETY SLEEVE COMPRESSION<br>TYPE, FEMALE PIPE END | MILITARY STANDARD<br><b>MS39209(AT)</b> |
| PROCUREMENT SPECIFICATION<br>NONE | SUPersedes:  | SHEET 1 OF 2                            |

APPROVED 24 APRIL 1962 REVISED 10 OCT 74 3 FEB 75 13 MAY 77 26 FEB 82

FED. SUP. CLASS  
**4730**

| DASH NO. | TUBE O.D. | A PIPE THREADS NPTF | B     | C THREAD LENGTH | D     | E       | F              | G     | H     | J              | K     | L       | M              | N     |       |
|----------|-----------|---------------------|-------|-----------------|-------|---------|----------------|-------|-------|----------------|-------|---------|----------------|-------|-------|
| 9        | 7/8       | 7/8                 | 3/4   | 3/16-16UN-2A    | 15/32 | 23/32   | .891<br>.895   | 11/32 | 13/64 | 1 3/16-16UN-2A | 15/32 | 23/32   | .891<br>.895   | 11/32 | 13/64 |
| 10       | 1         | 1                   | 1     | 5/16-16UN-2A    | 15/32 | 7/8     | 1.016<br>1.020 | 13/32 | 13/64 | 5/16-16UN-2A   | 15/32 | 7/8     | 1.016<br>1.020 | 13/32 | 13/64 |
| 11       | 1 1/4     | 1 1/4               | 1 1/4 | 5/8-16UN-2A     | 35/64 | 1 3/32  | 1.270<br>1.274 | 13/32 | 13/64 | 5/8-16UN-2A    | 35/64 | 1 3/32  | 1.270<br>1.274 | 13/32 | 13/64 |
| 12       | 1 1/2     | 1 1/2               | 1 1/2 | 7/8-16UN-2A     | 9/16  | 1 11/32 | 1.580<br>1.584 | 15/32 | 13/64 | 7/8-16UN-2A    | 9/16  | 1 11/32 | 1.580<br>1.584 | 15/32 | 13/64 |

| DASH NO. | O      | P      | Q     | R      | S      |
|----------|--------|--------|-------|--------|--------|
| 9        | 1 1/2  | 1 1/2  | 1 3/8 | 2 3/32 | 2 3/32 |
| 10       | 1 5/8  | 1 5/8  | 1 5/8 | 2 3/16 | 2 3/16 |
| 11       | 1 5/16 | 1 5/16 | 2     | 2 9/16 | 2 9/16 |
| 12       | 2 3/8  | 2 3/8  | 2 1/8 | 3 1/16 | 3 1/16 |

MATERIAL: STEEL, IN ACCORDANCE WITH FEDERAL STANDARD NO. 66, AISI-C-1112, C-1113, C-1117, C-1118 OR C-1137.

FINISH: CADMIUM PLATED, SPECIFICATION QQ-P-416, TYPE II, CLASS 3.

TOLERANCE: UNLESS OTHERWISE SPECIFIED, DECIMALS  $\pm .005$ , FRACTIONS  $\pm 1/64$ , DEGREES  $\pm 2^\circ$ .

THREADS: THE THREADS SHALL BE IN ACCORDANCE WITH MIL-STD-NR02/2/8.

PART NUMBER: THE PART NUMBER CONSISTS OF MS NUMBER PLUS THE DASH NUMBER, EXAMPLE: MS 39209-1.

THE PART NUMBER COVERS THE COMPLETE ITEM (WITH NUTS AND SLEEVES).

NOTES: 1. REFERENCED DOCUMENTS SHALL BE OF THE ISSUE IN EFFECT ON DATE OF INVITATIONS FOR BID.

2. THIS ILLUSTRATION IS FOR IDENTIFICATION AND IS NOT INTENDED TO RESTRICT DESIGNS OR SHAPES NOT DIMENSIONED.

**INACTIVE**—SEE SHEET L

APPROVED 24 APRIL 1962 REVISED

|                           |   |                    |
|---------------------------|---|--------------------|
| P.A.<br>Other Cost        | TITLE   | MILITARY STANDARD  |
|                           | TEES, PIPE TO TUBE - SAFETY SLEEVE COMPRESSION<br>TYPE, FEMALE PIPE END | <b>MS39209(AT)</b> |
| PROCUREMENT SPECIFICATION | SUPPLEMENT  | SHEET 2 OF 2       |

---

NOTICE  
OF VALIDATION

---

MS39209E(AT)  
NOTICE 1  
18 September 1987

MILITARY SPECIFICATION

TEES, PIPE TO TUBE-SAFETY SLEEVE  
COMPRESSION TYPE, FEMALE PIPE END

MS39209E(AT), dated 26 February 1982, has been reviewed and determined to be valid for maintenance purposes only.

Custodian:  
Army - AT

Preparing activity:  
Army - AT

AMSC N/A

FSC 4730

DISTRIBUTION STATEMENT A. Approved for public release; distribution is unlimited.

