

MS39202F
 1 February 2002
 SUPERSEDING
 MS39202E
 26 February 1982

DETAIL SPECIFICATION SHEET

ELBOWS, PIPE TO TUBE – SAFETY SLEEVE COMPRESSION
 TYPE, 90 DEGREE, MALE PIPE END

This specification is approved for use by all Departments and
 Agencies of the Department of Defense.

The requirements for acquiring the product described herein shall consist of this specification sheet.

NOTICE OF INACTIVATION FOR
 NEW DESIGN AS OF 29 DEC 1967.

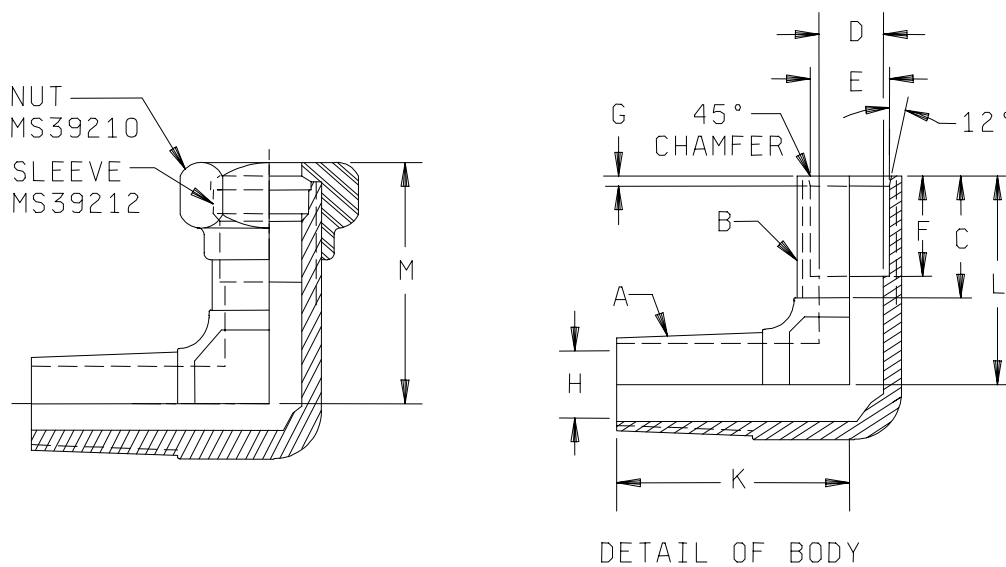

FIGURE 1. Elbows, pipe to tube – safety sleeve compression type, 90 degree, male pipe end.

MS39202F

TABLE 1. Elbows, pipe to tube-safety sleeve compression type, 90 degree, male pipe end.

Dash No.	Tube O.D.	A Pipe Thread NPTF	B	C Thread Length	D	E	F	G	H	K	L	M
1	1/8	1/8	5/16 24UNF-2A	9/32	3/32	.135 .139	13/64	1/8	3/16	3/4	21/32	31/32
2	3/16	1/8	3/8 24UNF-2A	9/32	1/8	.196 .200	1/4	5/32	3/16	3/4	21/32	1
3	1/4	1/8	1/2 20UNF-2A	13/32	13/64	.261 .265	19/64	13/64	3/16	25/32	3/4	1-5/32
4	5/16	1/8	9/16 18UNF-2A	13/32	13/64	.324 .328	19/64	13/64	3/16	25/32	13/16	1-3/16
5	1/4	1/4	1/2 20UNF-2A	13/32	13/64	.261 .265	19/64	13/64	9/32	1-1/16	7/8	1-9/32
6	3/8	1/4	5/8 18UNF-2A	7/16	9/32	.386 .390	19/64	13/64	9/32	1-1/16	15/16	1-3/8
7	3/8	3/8	5/8 18UNF-2A	7/16	9/32	.386 .390	19/64	13/64	27/64	1-3/16	1-1/8	1-9/16
8	1/2	3/8	3/4 16UNF-2A	7/16	27/64	.514 .518	5/16	13/64	27/64	1-3/16	1-1/8	1-21/32
9	5/8	3/8	15/16 16UN-2A	15/32	1/2	.641 .645	11/32	15/64	27/64	1-3/16	1-5/16	1-27/32
10	3/8	1/2	5/8 18UNF-2A	7/16	9/32	.386 .390	19/64	13/64	7/16	1-7/16	1-1/8	1-9/16
11	1/2	1/2	3/4 16UNF-2A	7/16	27/64	.541 .518	5/16	13/64	7/16	1-1/4	1-3/16	1-23/32
12	5/8	1/2	15/16 16UN-2A	15/32	1/2	.641 .645	11/32	15/64	1/2	1-7/16	1-5/16	1-27/32
13	3/4	1/2	1-1/16 16UN-2A	15/32	21/32	.766 .770	11/32	13/64	1/2	1-9/16	1-1/2	2-3/32
14	3/4	3/4	1-1/16 16UN-2A	15/32	21/32	.766 .770	11/32	13/64	23/32	1-9/16	1-1/2	2-3/32
15	7/8	3/4	1-3/16 16UN-2A	15/32	23/32	.891 .895	11/32	13/64	21/32	1-3/4	1-3/4	2-11/32
16	1	3/4	1-5/16 16UN-2A	15/32	7/8	1.016 1.020	13/32	13/64	23/32	1-3/4	1-3/4	2-11/32
17	7/8	1	1-3/16 16UN-2A	15/32	23/32	.891 .895	11/32	13/64	7/8	1-15/16	1-3/4	2-11/32
18	1	1	1-5/16 16UN-2A	15/32	7/8	1.016 1.020	13/32	13/64	7/8	1-15/16	1-3/4	2-11/32
19	1-1/4	1	1-5/8 16UN-2A	35/64	1-3/32	1.270 1.274	13/32	13/64	7/8	1-5/16	2-1/4	2-7/8
20	1-1/4	1-1/4	1-5/8 16UN-2A	17/32	1-3/32	1.270 1.274	13/32	13/64	1-1/8	2-5/16	2-1/4	2-7/8
21	1-1/2	1-1/2	1-7/8 16UN-2A	9/16	1-11/32	1.520 1.524	15/32	13/64	1-11/32	2-9/16	2-3/8	3-1/16

MS39202F

NOTES:

1. Dimensions are in inches.
2. Referenced documents shall be of the issue in effect in date of invitations for bid.
3. This illustration is for identification and is not intended to restrict designs or shapes not dimensioned.

REQUIREMENTS:

Dimensions and configuration: See figure 1.

Material: Carbon steel in accordance with SAE-AMS-STD-66, AISI-C-1112, C-1113, C-1117, C-1118 or C-1137.

Finish: Cadmium plated, specification QQ-P-416, type II, class 3. To the users of this document, it is recommended that the use of steel and cadmium plating be used only when other materials and finishes specified in the document cannot meet performance requirements.

Tolerances: Unless otherwise specified, decimals ± 0.005 , fractions $\pm 1/64$, degrees $\pm 2^\circ$.

Threads: The threads shall be in accordance with FED-STD-H28A.

Part or Identifying Number (PIN) example: (PIN covers the complete item with nuts and sleeves.)

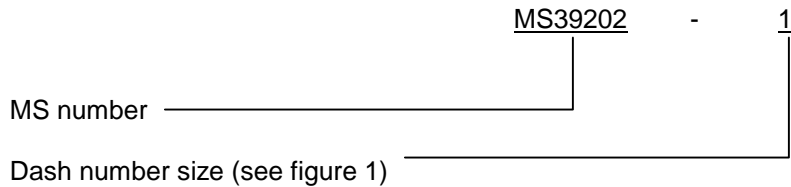

CONCLUDING MATERIAL

Custodians:
Army - AT
DLA - CC

Preparing activity:
DLA - CC

(Project 4730-2192)