

FED. SUP CLASS
5975

Reviewer/user information is current as of the date of this document. For future coordination of changes to this document, draft circulation should be based on the information in the current DD0153 (FSC listing).
 AF 88/82/ AF 88/82/ AF 88/82/

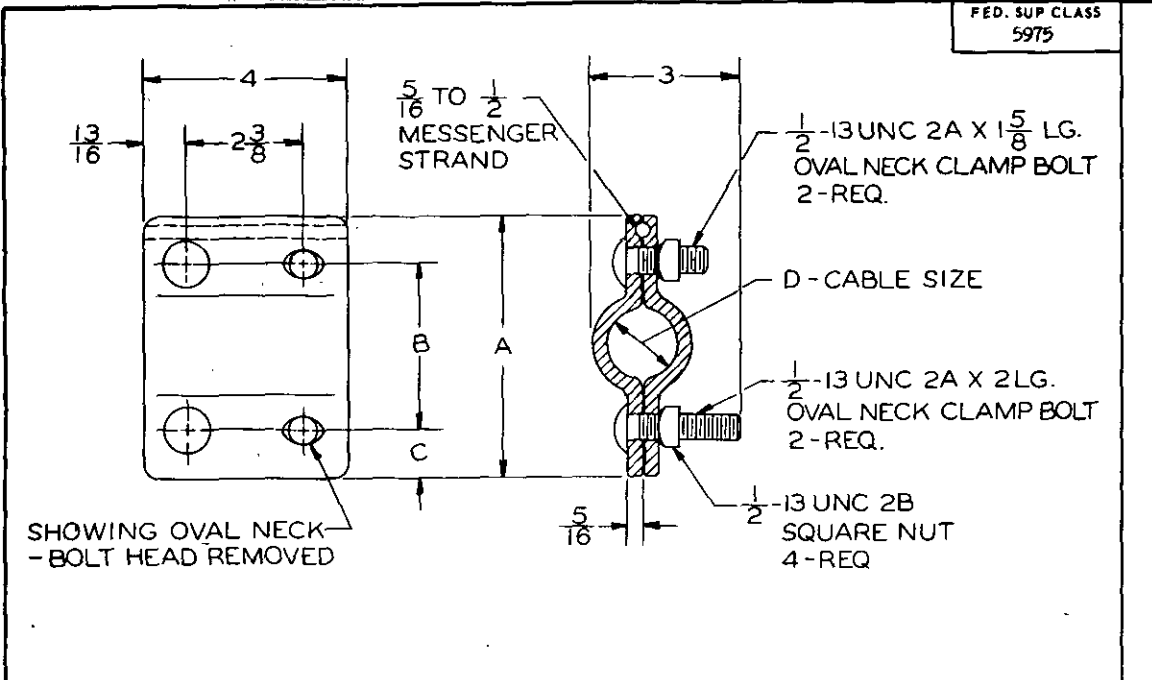

DASH NO.	A	B	C	D
-1	5 1/4	3 1/4	1	1 3/8
-2	6 1/4	4	1 1/8	2 1/16

NOTES:

1. REFERENCED DOCUMENTS SHALL BE OF THE ISSUE IN EFFECT ON DATE OF INVITATIONS FOR BID.
2. THIS STANDARD TAKES PRECEDENCE OVER DOCUMENTS REFERENCED HEREIN.
3. STEEL SHALL BE IN ACCORDANCE WITH FEDERAL SPECIFICATIONS QQ-S-698 AND QQ-W-405.
4. FINISH SHALL BE HOT DIP GALVANIZED IN ACCORDANCE WITH MILITARY SPECIFICATION MIL-Z-17871.
5. THREADS OF NUTS SHALL NOT BE GALVANIZED.
6. SCREW THREADS SHALL BE UNC-2 PER NATIONAL BUREAU OF STANDARDS PUBLICATION H-28.

Ⓐ CANCELLED AFTER 31 DEC 1967. NO SUPERSEDING STANDARD.

This military standard has been approved by the Department of Defense and is mandatory for use by all Departments and Agencies of the Department of Defense. Selection for all new engineering and design applications and for repetitive use shall be made from this document.

APPROVED 18 JULY 58 REVISED (A) 31 December 1967

P.A. EL Other Cust YD 82	TITLE HANGER, WIRESTRAND GRADE CLAMP (POLE LINE)	MILITARY STANDARD MS 39036
PROCUREMENT SPECIFICATION MIL-H-55053	SUPERSEDES:	SHEET 1 OF 1