

2-8

This document has been promulgated by the Department of Defense as the Military Standard to limit the selection of the item, product, or design covered herein in engineering, design, and procurement. This standard shall become effective not later than 90 days after the latest date of approval shown.

FED SUP CLASS
5975

NOTICE: When Government drawings, specifications, or other data are used for any purpose other than in connection with a definitely related Government procurement operation, the United States Government thereby incurs no responsibility, nor any obligation whatsoever; and the fact that the Government may have furnished, furnished, or in any way supplied the said drawings, specifications, or other data is not to be regarded by implication or otherwise as in any manner licensing the holder or any other person or corporation, or conveying any rights or permission to manufacture, use, or sell any patented invention that may in any way be related thereto.

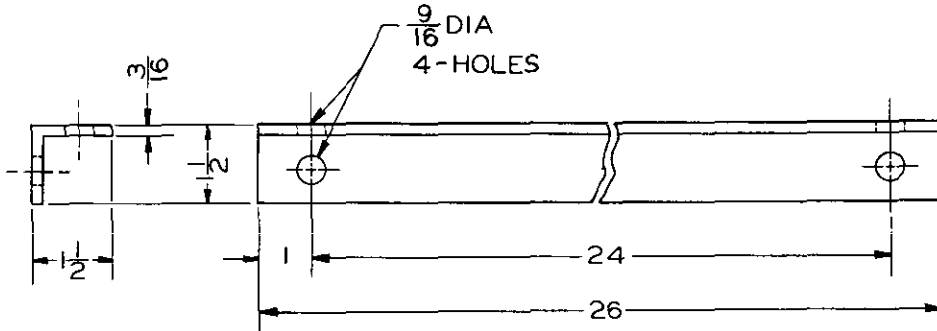

NOTES:

1. REFERENCED DOCUMENTS SHALL BE OF THE ISSUE IN EFFECT ON DATE OF INVITATIONS FOR BID.
2. THIS STANDARD TAKES PRECEDENCE OVER DOCUMENTS REFERENCED HEREIN.
3. STEEL - SHALL BE IN ACCORDANCE WITH FEDERAL SPECIFICATION QQ-S-741, TYPE I, GRADE B, CLASS 1.
4. FINISH - SHALL BE NOT DIP GALVANIZED IN ACCORDANCE WITH MILITARY SPECIFICATION MIL-Z-17871.

Ⓐ CANCELLED AFTER 22 MAY 1967. NO SUPERSEDING STANDARD.

DASH NO.	FIIN
-1	

ALL DIMENSIONS IN INCHES

CUSTODIANS SigC MC USAP	OTHER INT. A- CR	MILITARY STANDARD BRACE, CROSSARM, VERTICAL	MS39034
	N- YS AF-		
PROCUREMENT SPECIFICATION	SUPERSEDES:	SHEET 1 OF 1	

APPROVED 16 JULY 58 REVISED Ⓐ 22 MAY 1967