

FED. SUP CLASS
4820

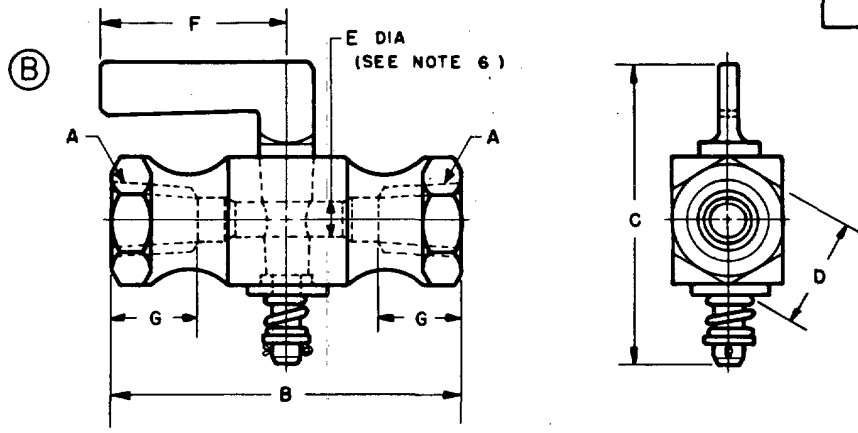

REVIEWER: AT, GI, ME, MU
USER: CS, EL, MI, YD

DASH NUMBER	A PIPE THREAD NPTF	B MAX	C MAX	D ACROSS FLATS ±0.02	E MIN	F MAX	G MAX
1	1/8-27	1.75	1.94	0.56 or 0.75	0.16	1.38	0.38
2	1/4-18	2.12	2.06	0.75 or 0.88	0.19	1.38	0.56
3	3/8-18	2.44	2.44	0.88 or 0.94	0.19	1.69	0.56
4	1/2-14	3.00	2.56	1.25 or 1.16	0.25	2.12	0.75

NOTES:

- 1. **MATERIAL:** Brass, QQ-B-626, Alloy Number 268 or 360 or QQ-C-390, Alloy Number B5. Spring shall be Phosphor-Bronze conforming to QQ-W-321, Alloy Number 510.
- 2. **PROTECTIVE COATING:** None.
- 3. **THREADS:** Threads shall be in accordance with Screw-Thread Standards for Federal Services, Handbook H28.
- 4. **DIMENSIONS:** Unless otherwise specified all dimensions are in inches.
- 5. The illustration is for identification purpose only and is not intended to restrict designs or shapes not dimensioned.
- 6. Oval port having same cross sectional area is acceptable.
- 7. **PART NUMBER:** The MS part number consists of the MS number, plus the dash number. Example: MS35930-1.
- 8. For design feature purposes, this standard takes precedence over procurement documents referenced herein.
- 9. Reference documents shall be of the issue in effect on date of invitations for bid.
- 10. This item is for use in liquid or gas systems where the pressure does not exceed 50 p.s.i. and the liquid or gas is compatible with brass.

This military standard is mandatory for use by all Departments and Agencies of the Department of Defense. Selection for all new engineering and design applications and for repetitive use shall be made from this document.

APPROVED 17 FEB 59 REVISED (A) 14 SEPT 67 (B) 28 SEPT 73

P.A. WC Other Cust SH 82	TITLE (B) COCK, PLUG: SPRING KEY, THREADED TYPE, 50 P.S.I.	MILITARY STANDARD MS35930
PROCUREMENT SPECIFICATION MIL-C-1203	SUPERSEDES:	SHEET 1 OF 1

DD FORM 672-1 (Coordinated)

PREVIOUS EDITIONS OF THIS FORM ARE OBSOLETE.