

FED. SUP. CLASS  
2930

REVIEW ACTIVITIES:  
USER ACTIVITIES: ARMY-GL; NAVY - SH

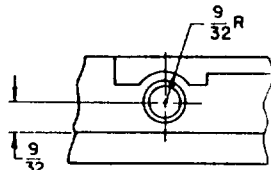

ENLARGED VIEW OF OVERFLOW HOLE.  
DESIGN OPTIONAL

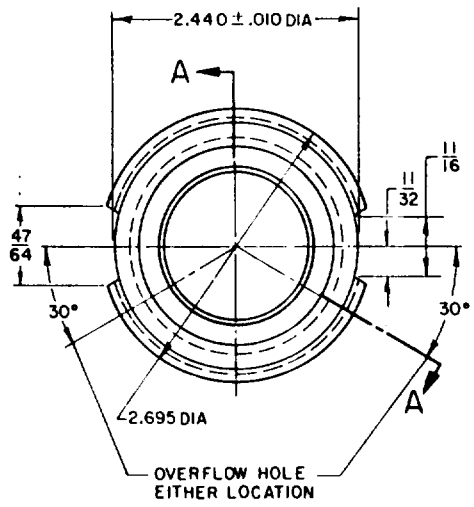

OVERFLOW HOLE  
EITHER LOCATION

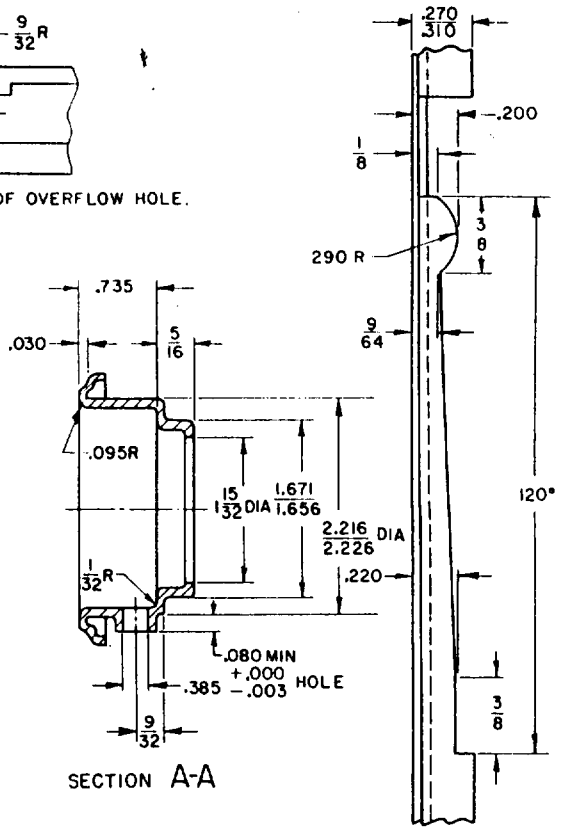

SECTION A-A

CAM DEVELOPMENT

NOTES:

- (C) 1. MATERIAL: BRASS ALLOY 240, 260 OR 264; TEMPER-ANNEAL PER QQ-B-613 OR QQ-B-626 (.010 THICK).
- 2. THE FILLER NECK SHALL BE FREE OF BURRS AND FUNCTIONAL DEFECTS.
- 3. DIMENSIONS ARE IN INCHES, UNLESS OTHERWISE SPECIFIED, TOLERANCES ARE  $\pm 1/4$  ON FRACTIONS,  $\pm .005$  ON DECIMALS,  $\pm 1^\circ$  ON ANGLES.
- 4. FOR DESIGN FEATURE PURPOSES, THIS STANDARD TAKES PRECEDENCE OVER PROCUREMENT DOCUMENTS REFERENCED HEREIN.
- 5. THIS STANDARD IS NOT INTENDED TO LIMIT CONSTRUCTION TO FEATURES OTHER THAN AS SHOWN HEREON BY DIMENSIONS, NOTATIONS, OR REFERENCED DOCUMENTS.
- 6. REFERENCED DOCUMENTS SHALL BE OF THE ISSUE IN EFFECT OF INVITATIONS FOR BID.
- 7. MARKING SHALL CONSIST OF THE MS PART NUMBER AND MANUFACTURER'S IDENTIFICATION IN ACCORDANCE WITH MIL-STD-130.

This military standard is approved for use by all Departments and Agencies of the Department of Defense. Selection for all new engineering and design applications and for repetitive use shall be made from this document.

APPROVED 12 SEPTEMBER 1957 REVISED (A) 8 MARCH 1962 (B) 21 MARCH 1968 (C) 15 JANUARY 1974

P.A. ARMY-AT		TITLE		MS PART NO.		FORMER PART NO.	
Other Cust AF-82		FILLER NECK: RADIATOR (7PSI)		MS 35841-1		5343093	
PROCUREMENT SPECIFICATION NONE		SUPERSEDES		<b>MILITARY STANDARD</b>			
				<b>MS 35841</b>			
				SHEET 1 OF 1			

SPECIFICATION ANALYSIS SHEET		Form Approved Budget Bureau No. 22-R255
<p><b>INSTRUCTIONS:</b> This sheet is to be filled out by personnel, either Government or contractor, involved in the use of the specification in procurement of products for ultimate use by the Department of Defense. This sheet is provided for obtaining information on the use of this specification which will insure that suitable products can be procured with a minimum amount of delay and at the least cost. Comments and the return of this form will be appreciated. Fold on lines on reverse side, staple in corner, and send to preparing activity. Comments and suggestions submitted on this form do not constitute or imply authorization to waive any portion of the referenced document(s) or serve to amend contractual requirements.</p>		
SPECIFICATION		
MS35841		
ORGANIZATION		
CITY AND STATE		CONTRACT NUMBER
MATERIAL PROCURED UNDER A		
<input type="checkbox"/> DIRECT GOVERNMENT CONTRACT <input type="checkbox"/> SUBCONTRACT		
<p>1. HAS ANY PART OF THE SPECIFICATION CREATED PROBLEMS OR REQUIRED INTERPRETATION IN PROCUREMENT USE?</p> <p>A. GIVE PARAGRAPH NUMBER AND WORDING.</p>		
<p>B. RECOMMENDATIONS FOR CORRECTING THE DEFICIENCIES</p>		
<p>2. COMMENTS ON ANY SPECIFICATION REQUIREMENT CONSIDERED TOO RIGID</p>		
<p>3. IS THE SPECIFICATION RESTRICTIVE?</p> <p><input type="checkbox"/> YES      <input type="checkbox"/> NO (If "yes", in what way?)</p>		
<p>4. REMARKS (Attach any pertinent data which may be of use in improving this specification. If there are additional papers, attach to form and place both in an envelope addressed to preparing activity)</p>		
SUBMITTED BY (Printed or typed name and activity - Optional)		DATE

DD FORM 1426  
1 JAN 66

REPLACES EDITION OF 1 OCT 64 WHICH MAY BE USED.

FOLD

---

POSTAGE AND FEES PAID  
DEFENSE SUPPLY AGENCY

DEFENSE SUPPLY AGENCY  
OFFICIAL BUSINESS

Commander  
US Army Tank-Automotive Command  
ATTN: AMSTA-RSEM  
Warren, Michigan 48090

---

FOLD