

FED. SUP CLASS
4730

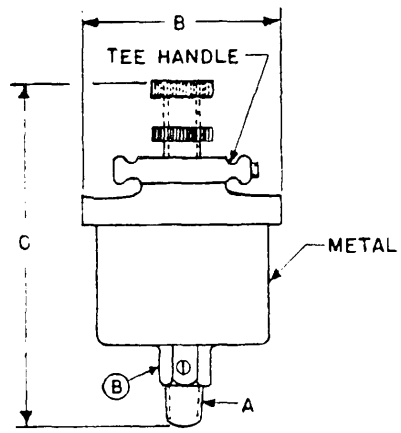

FIGURE - 1

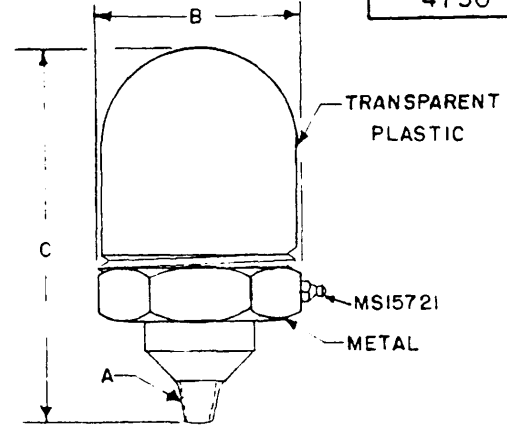

FIGURE - 2

REVISOR: AT-ME-CS
SER: AS-EL-6L-MC-YD

FIGURE 1				
DASH NUMBER	GREASE CAPACITY OUNCE	(B) A THREAD NPT	(B) B OUTSIDE DIAMETER MAX	(D) C OVERALL LENGTH MAX
1	1/3	1/8-27	1 11/32	3 1/4
2	1	3/4-16	1 13/16	4 1/4
* 3	1 1/2	1/4-18	2	4 7/8
* 4	3	3/8-18	2 3/4	6 1/8
* 5	4	1/2-14	3 3/16	7 1/4

FIGURE 2				
DASH NUMBER	GREASE CAPACITY OUNCE	(B) A THREAD NPT	(B) B OUTSIDE DIAMETER MAX	(D) C OVERALL LENGTH MAX
* 6	2	1/4-18	1 3/4	3 1/4
7	4	3/8-16	2 1/4	5
* 8	10	3/8-18	3 1/2	6 1/2

* Inactivate for new design after 18 MAR 71

NOTES:

- (B) 1. **MATERIAL:** For metal parts:
 Steel - Federal Standard No. 60, Table 1, Steel Number 1010 thru 1095.
 Zinc Alloy - QQ-Z-363.
 Brass - QQ-B-613, Composition 260 or 265; or QQ-B-626, Composition 360; or QQ-C-100.
 Alloy Number - B5.
 Aluminum - QQ-A-250/4.
 Springs - QQ-W-425, Type 11.
 Other parts:
 Plastic - L-P-349, Type 1, Class H2 or NH.
 Leather - AH-L-164, Tannage 111, or Class 1, Treatment A of Tannage 11.
 Rubber - MIL-R-3065, Grade SC 515, A1, B1, E3, F2.
- (B) 2. **PROTECTIVE COATING:** Steel and zinc alloy parts are cadmium plated in accordance with QQ-P-416, Type 11, Class 3.
- 3. **THREADS:** Thread dimensions shall be in accordance with Screw Thread Standards for Federal Services, Handbook H26.
- 4. **DIMENSIONS:** All dimensions are in inches.
- 5. **PART NUMBER:** The MS part number consists of the MS number, plus the dash number.
 Example: MS35759-1
- 6. For design feature purposes, this standard takes precedence over procurement documents referenced herein.
- 7. Reference documents shall be of the issue in effect on date of invitations for bid.
- 8. The illustration is for identification only and is not intended to restrict design or shapes not dimensioned.
- 9. Figure 1 represents Type II, Class 1, Style 1, and Figure 2 represents Type II, Class 1, Style 2 or Class 2 of procurement specification.

This military standard is mandatory for use by all Departments and Agencies of the Department of Defense. Selection for all new engineering and design applications and for repetitive use shall be made from this document.

P.A. WC	TITLE	MILITARY STANDARD
Other Cust SH 62	CUPS, GREASE, AUTOMATIC FEED	MS35759
PROCUREMENT SPECIFICATION MIL-C-1233	SUPERSEDES:	SHEET 1 OF 1

APPROVED 22 AUG 1956 REVISED 25 MAY 1961 18 MAR 71

