

FED. SUP CLASS
5330

REVIEW ACTIVITY:
USER ACTIVITIES: ARMY-ME, NAVY-YD, MC

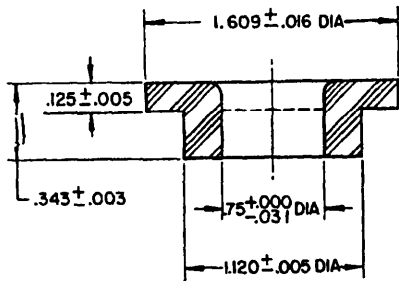

SECTION A-A

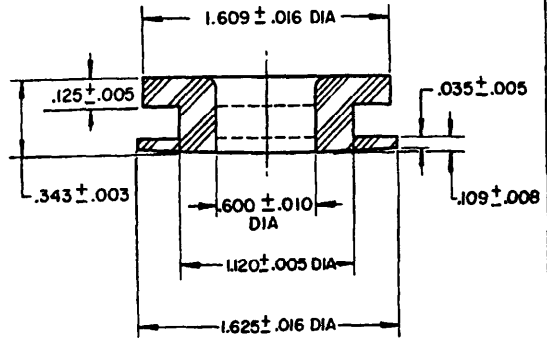

SECTION A-A

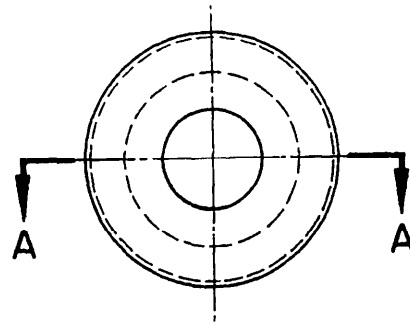
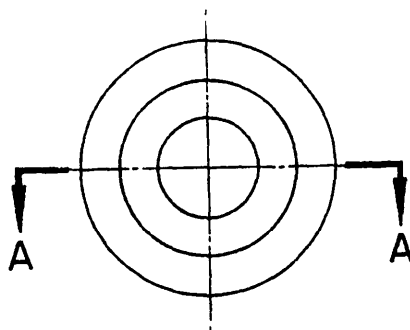

OPTIONAL DESIGNS

NOTES:

1. OPTIONAL DESIGNS SHOWN ARE INTERCHANGEABLE FUNCTIONALLY AND PHYSICALLY.
2. MATERIAL: RUBBER, GRADE SC 715, B₁ C₁ F₂, SPECIFICATION MIL-R-3065.
3. THIS PACKING IS A COMPONENT OF COUPLING, AIR BRAKE LINES: MS 35746.
4. DIMENSIONS ARE IN INCHES.
5. FOR DESIGN FEATURE PURPOSES, THIS STANDARD TAKES PRECEDENCE OVER PROCUREMENT DOCUMENTS REFERENCED HEREIN.
6. REFERENCED DOCUMENTS SHALL BE OF THE ISSUE IN EFFECT ON DATE OF INVITATION FOR BIDS.

ALL PROVISIONS OF THIS STANDARD ARE THE SUBJECT OF INTERNATIONAL STANDARDIZATION AGREEMENT NATO STANAG 2604 AND QSTAG-310 WHEN REVISION OR CANCELLATION OF THIS STANDARD IS PROPOSED WHICH WILL EFFECT OR VIOLATE THE INTERNATIONAL AGREEMENT CONCERNED, THE PREPARING ACTIVITY WILL TAKE APPROPRIATE RECONCILIATION ACTION THROUGH INTERNATIONAL STANDARDIZATION CHANNELS, INCLUDING DEPARTMENTAL STANDARDIZATION OFFICES, IF REQUIRED.

MS PART NO	FORMER PART NO
MS 35748-1	538824

P.A. ARMY - AT Other Cust Navy - AF - 84	International Interest	TITLE PACKING, PREFORMED: AIR COUPLING	MILITARY STANDARD MS 35748
PROCUREMENT SPECIFICATION NONE	SUPERSEDES: CFGX1	SHEET	OF

This military standard is mandatory for use by all Departments and Agencies of the Department of Defense. Selection for all new engineering and design applications and for repetitive use shall be made from this document.

APPROVED 3 MAY 1956 REVISED (A) 16 MARCH 1962 (B) 29 APRIL 1964 (C) 24 APRIL 1967 (D) 27 DECEMBER 1972 (E) 28 JANUARY 1974

SPECIFICATION ANALYSIS SHEET		Form Approved Budget Bureau No. 22-R255
<p>INSTRUCTIONS: This sheet is to be filled out by personnel, either Government or contractor, involved in the use of the specification in procurement of products for ultimate use by the Department of Defense. This sheet is provided for obtaining information on the use of this specification which will insure that suitable products can be procured with a minimum amount of delay and at the least cost. Comments and the return of this form will be appreciated. Fold on lines on reverse side, staple in corner, and send to preparing activity. Comments and suggestions submitted on this form do not constitute or imply authorization to waive any portion of the referenced document(s) or serve to amend contractual requirements.</p>		
<p>SPECIFICATION MS35748, Revision "E"</p>		
<p>ORGANIZATION</p>		
<p>CITY AND STATE</p>		<p>CONTRACT NUMBER</p>
<p>MATERIAL PROCURED UNDER A <input type="checkbox"/> DIRECT GOVERNMENT CONTRACT <input type="checkbox"/> SUBCONTRACT</p>		
<p>1. HAS ANY PART OF THE SPECIFICATION CREATED PROBLEMS OR REQUIRED INTERPRETATION IN PROCUREMENT USE? A. GIVE PARAGRAPH NUMBER AND WORDING.</p>		
<p>B. RECOMMENDATIONS FOR CORRECTING THE DEFICIENCIES</p>		
<p>2. COMMENTS ON ANY SPECIFICATION REQUIREMENT CONSIDERED TOO RIGID</p>		
<p>3. IS THE SPECIFICATION RESTRICTIVE? <input type="checkbox"/> YES <input type="checkbox"/> NO (If "yes", in what way?)</p>		
<p>4. REMARKS (Attach any pertinent data which may be of use in improving this specification. If there are additional papers, attach to form and place both in an envelope addressed to preparing activity)</p>		
<p>SUBMITTED BY (Printed or typed name and activity - Optional)</p>		<p>DATE</p>

DD FORM 1426
1 JAN 66

REPLACES EDITION OF 1 OCT 64 WHICH MAY BE USED.

FOLD

POSTAGE AND FEES PAID
DEFENSE SUPPLY AGENCY

DEFENSE SUPPLY AGENCY
OFFICIAL BUSINESS

Commander
US Army Tank-Automotive Command
ATTN: AMSTA-RSEM
Warren, Michigan 48090

FOLD

