

FED SUP CLASS  
4730

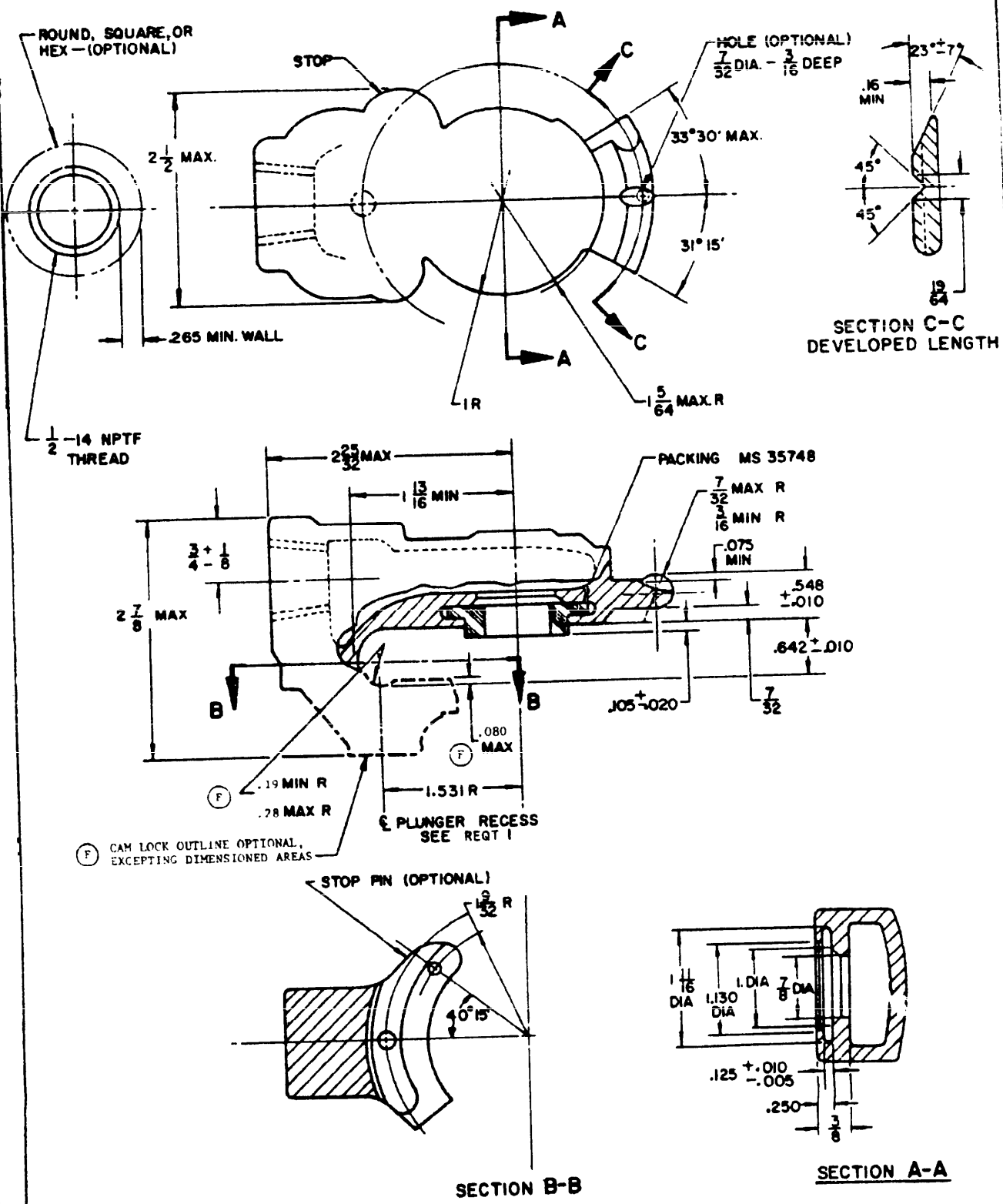

REVIEW ACTIVITY: DLA-CS  
ARMY-NE; NAVY-MC  
USER ACTIVITIES:

This military standard is approved for use by all Departments and Agencies of the Department of Defense. Section for all new engineering and design applications and for repetitive use shall be made from this document when applicable.

(F) CAM LOCK OUTLINE OPTIONAL, EXCEPTING DIMENSIONED AREAS

(F) DENOTES CHANGES

APPROVED 3 MAY 56 REVISED (A) 16 MAR 62 (B) 11 FEB 64 (C) 25 OCT 65 (D) 24 APRIL 1967 (E) 24 JUNE 1974

P.A. ARMY-AT Other Cust AF-99	International Interest	TITLE <b>COUPLING, AUTOMOTIVE: AIR BRAKE LINES</b>	<b>MILITARY STANDARD MS 35746</b>
PROCUREMENT SPECIFICATION MIL - C - 62005	SUPERSEDES		SHEET 1 OF 2

FED. SUP CLASS  
4730

Ⓡ REQUIREMENTS:

1. A POSITIVE STOP AND LOCKING DEVICE SHALL BE PROVIDED FOR POSITIONING THE MATED COUPLING. THE TYPE OF STOP IS OPTIONAL.
2. THREADS SHALL BE IN ACCORDANCE WITH SCREW-THREAD STANDARDS FOR FEDERAL SERVICES, HANDBOOK H28/2/R.
3. REFERENCED DOCUMENTS SHALL BE OF THE ISSUE IN EFFECT ON DATE OF INVITATION FOR BIDS.
4. MARKING SHALL CONSIST OF THE MS PART NUMBER AND MANUFACTURER'S IDENTIFICATION IN ACCORDANCE WITH MIL-STD-130.

Ⓡ NOTES:

1. UNLESS OTHERWISE SPECIFIED, DIMENSIONS ARE IN INCHES, TOLERANCES ARE  $\pm 1/64$  ON FRACTIONS,  $\pm .005$  ON DECIMALS, AND  $\pm 1/2^\circ$  ON ANGLES.
2. THIS STANDARD IS NOT INTENDED TO LIMIT CONSTRUCTION TO FEATURES OTHER THAN AS SHOWN HEREON, BY DIMENSIONS, NOTATIONS, OR REFERENCED DOCUMENTS.
3. FOR DESIGN FEATURE PURPOSES, THIS STANDARD TAKES PRECEDENCE OVER PROCUREMENT DOCUMENTS REFERENCED HEREIN.
4. THE USE OF RECYCLED MATERIALS WHICH MEET THE REQUIREMENTS OF THE APPLICABLE MATERIAL SPECIFICATIONS WITHOUT JEOPARDIZING THE INTENDED USE OF THE ITEM SHALL BE ENCOURAGED.

ALL PROVISIONS OF THIS STANDARD ARE THE SUBJECT OF INTERNATIONAL STANDARDIZATION AGREEMENT NATO STANAG 2604 AND QSTAG 310, WHEN REVISION OR CANCELLATION OF THIS STANDARD IS PROPOSED WHICH WILL EFFECT OR VIOLATE THE INTERNATIONAL AGREEMENT CONCERNED, THE PREPARING ACTIVITY WILL TAKE APPROPRIATE RECONCILIATION ACTION THROUGH INTERNATIONAL STANDARDIZATION CHANNELS, INCLUDING DEPARTMENTAL STANDARDIZATION OFFICES, IF REQUIRED.

REVISÉ Ⓡ FOR CHANGES SEE SHEETS 1 AND 2  
APPROVED

P.A. Other Cost	International Interest	TITLE <b>COUPLING, AUTOMOTIVE: AIR BRAKE LINES</b>	<b>MILITARY STANDARD</b>	
			<b>MS 35746</b>	
PROCUREMENT SPECIFICATION		SUPersedes:	SHEET 2 OF 2	