

FED. SUP CLASS
5120

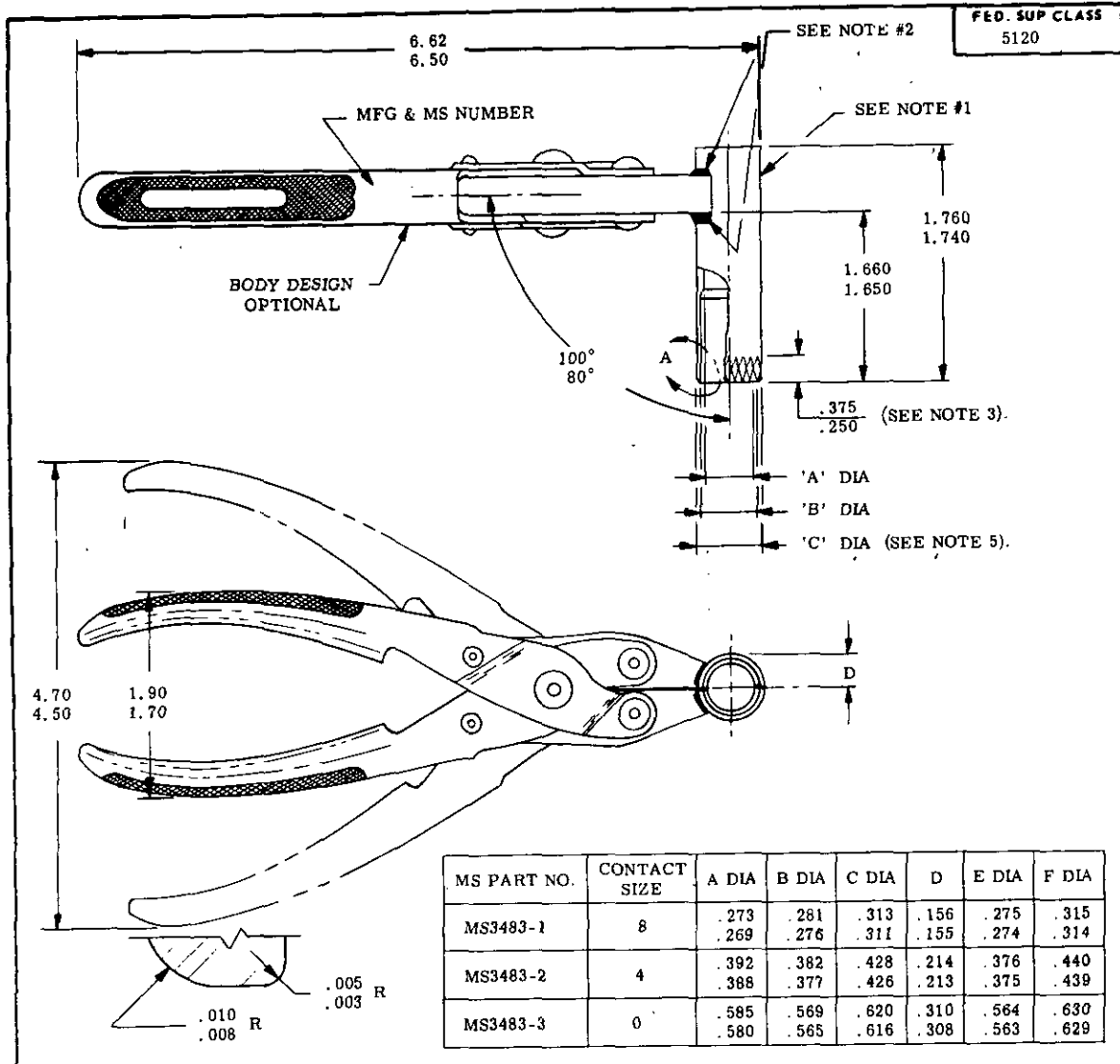

MS PART NO.	CONTACT SIZE	A DIA	B DIA	C DIA	D	E DIA	F DIA
MS3483-1	8	.273 .269	.281 .276	.313 .311	.156 .155	.275 .274	.315 .314
MS3483-2	4	.392 .388	.382 .377	.428 .426	.214 .213	.376 .375	.440 .439
MS3483-3	0	.585 .580	.569 .565	.620 .616	.310 .308	.564 .563	.630 .629

DETAIL 'A'

(A) CANCELED AFTER 20 JUNE 1979
USE MIL-I-81969/15

NOTES:

1. MATERIAL 304 STAINLESS FULL HARD.
2. BEAD OF WELD (OR BRAZE) NOT TO EXCEED .100 IN WIDTH ON BOTTOM JOINT.
3. BOTH EXTRACTOR TIPS (INSIDE AND OUTSIDE DIA) TO BE COATED TO DIMENSION SHOWN WITH STRATIFIED POLYTETRAFLUOROETHYLENE .00075/.00055 THICK OR EQUIVALENT.
4. INTENDED USE: REMOVAL OF CONTACTS FROM MIL-C-005015 (NAVY) REAR RELEASE CONNECTORS.
5. WITH TIPS CLOSED AROUND 'E' DIA PIN, TIPS SHALL ENTER A RING GAGE OF 'F' DIA.
6. DIMENSIONS ARE IN INCHES.

This military standard is approved by Department of the Navy and shall be used by that activity. All other military activities are required to employ this standard where suitable.

P.A. NAVY - AS Other Cust	TITLE REMOVAL TOOLS, CONNECTOR, CONTACT ELECTRICAL SIZE 8, 4 AND 0	MILITARY STANDARD MS3483(NAVY)
PROCUREMENT SPECIFICATION	SUPERSEDES:	SHEET 1 OF 1

APPROVED 5 APT 74 REVISED (A) 20 JUNE 1979

REVIEW ACTIVITIES
NAVY - EC