

PROJ. NO. 012216612
 FED. SUP. CLASS
 5120

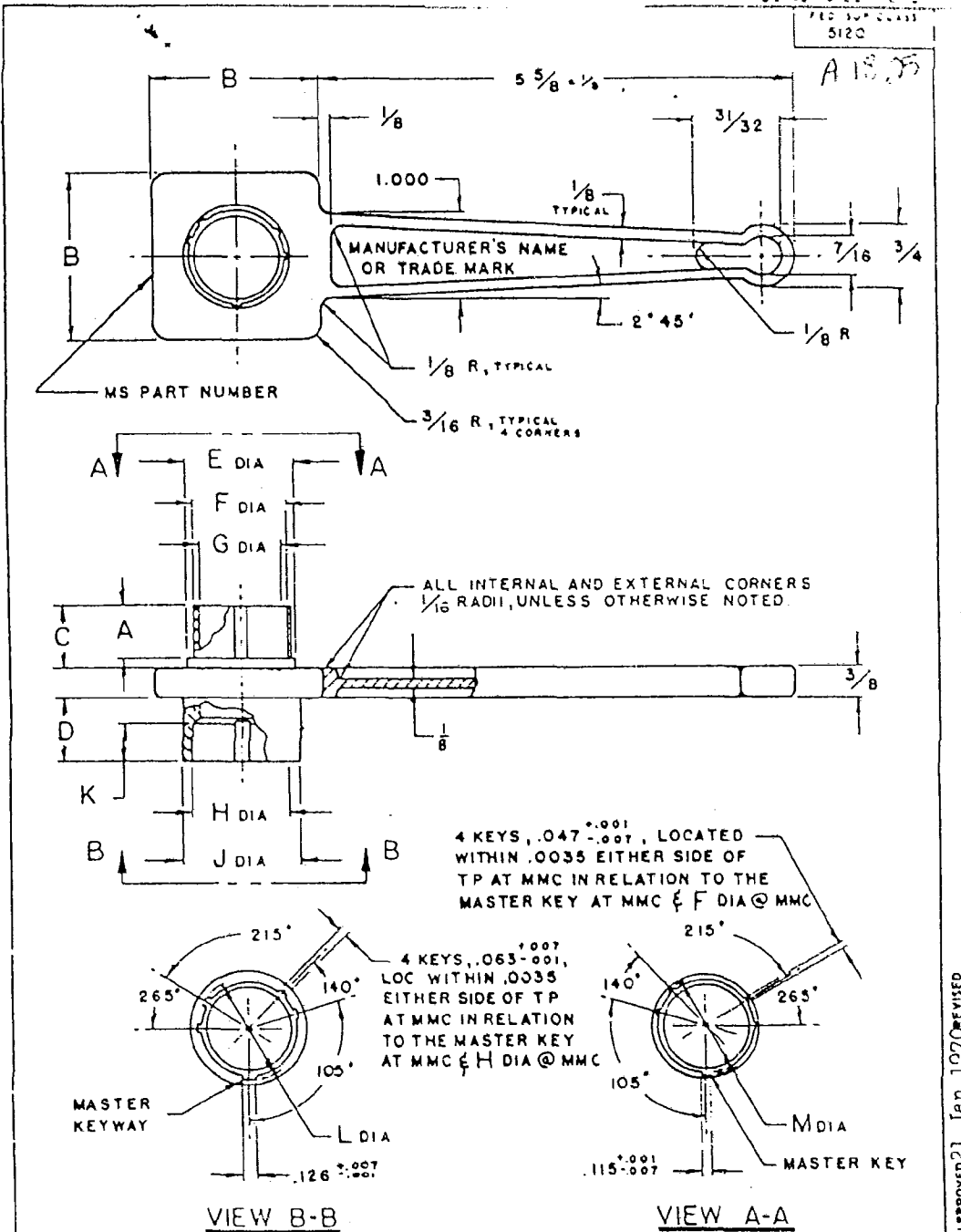

APPROVED 21 JAN 1970 REVISED

P.A. NAVY-AS Other Cost	TITLE TOOL, CONNECTOR ASSEMBLY; FOR MIL-C-26482 CONNECTORS	MILITARY STANDARD MS3481(NAVY)
PROCUREMENT SPECIFICATION NONE	SUPERSEDES	SHEET 1 OF 2

This military standard is approved by the Department of the Navy and is mandatory for use by the Department. All other military activities are required to comply with applicable provisions.

Dimensions are given in inches unless otherwise specified. All other factory tolerances are standard.

DASH NUMBER	CONNECTOR SHELL SIZE	A ±.030	B ±.060	C APPROX	D APPROX	E DIA APPROX	F DIA ±.005	G DIA MIN	H DIA ±.005	J DIA ±.005	K MIN	L DIA ±.005	M DIA ±.010
-08	B					.473	.357	.292	.362	.473		.412	.402
-10	10		1.250			.590	.485	.409	.490	.590		.540	.530
-12	12	3.80		.410	.455	.750	.597	.523	.607	.750	.281	.689	.679
-14	14					.875	.722	.648	.732	.875		.814	.804
-16	16					1.000	.847	.772	.857	1.000		.939	.929
-18	18					1.125	.947	.862	.962	1.125		1.039	1.029
20	20		2.000			1.250	1.072	.987	1.087	1.250		1.164	1.154
-22	22	4.25		.495	.540	1.375	1.197	1.111	1.212	1.375	.343	1.289	1.279
-24	24					1.500	1.322	1.237	1.337	1.500		1.414	1.404

REQUIREMENTS:

- TOOLS ARE FOR USE WITH CONNECTORS CONFORMING TO MIL-C-26482.
- PART NUMBER SHALL INCLUDE: MS PART NUMBER AND DASH NUMBER AS SHOWN IN THE EXAMPLE BELOW.
 MS NUMBER MS 3481-24 DASH NUMBER

NOTES:

- MATERIAL: a. SHELL; HIGH GRADE ALUMINUM ALLOY.
 b. HANDLE; DIE CAST ALUMINUM ALLOY PER QQ-A-591.
- FINISH: NICKEL PLATE PER QQ-N-290
- REMOVE ALL BURRS AND SHARP EDGES.
- ALL DIMENSIONS ARE INCHES, UNLESS OTHERWISE SPECIFIED. TOLERANCES: FRACTIONS ± 1/16, ANGLES: TP DECIMALS ± .016

FOR DESIGN FEATURE PURPOSES, THIS STANDARD TAKES PRECEDENCE OVER PROCUREMENT DOCUMENTS REFERENCED HEREIN.
 REFERENCED DOCUMENTS SHALL BE OF THE ISSUE IN EFFECT ON DATE OF INVITATIONS FOR BID.

Approved: [Signature] Jan 1978

NAVY - AS
 Other Code

TITLE
 TOOL, CONNECTOR ASSEMBLY, FOR
 MIL-C-26482 CONNECTORS

MILITARY STANDARD
 MS3481(NAVY)

PROCUREMENT SPECIFICATION SUPERSEDES
 NONE

SHEET 2