

INCH-POUND

MS3471E
 1 March 2007
 SUPERSEDING
 MS3471D
 12 July 1985

DETAIL SPECIFICATION SHEET

CONNECTORS, RECEPTACLE, ELECTRICAL, SERIES II, CRIMP TYPE,
 CABLE CONNECTING, BAYONET COUPLING, CLASSES A, L and W

Reactivated after 1 March 2007 and may be used
 for new and existing designs and acquisitions.

This specification is approved for use by all Departments and
 Agencies of the Department of Defense.

The requirements for acquiring the product described herein
 shall consist of this specification sheet and MIL-DTL-26482.

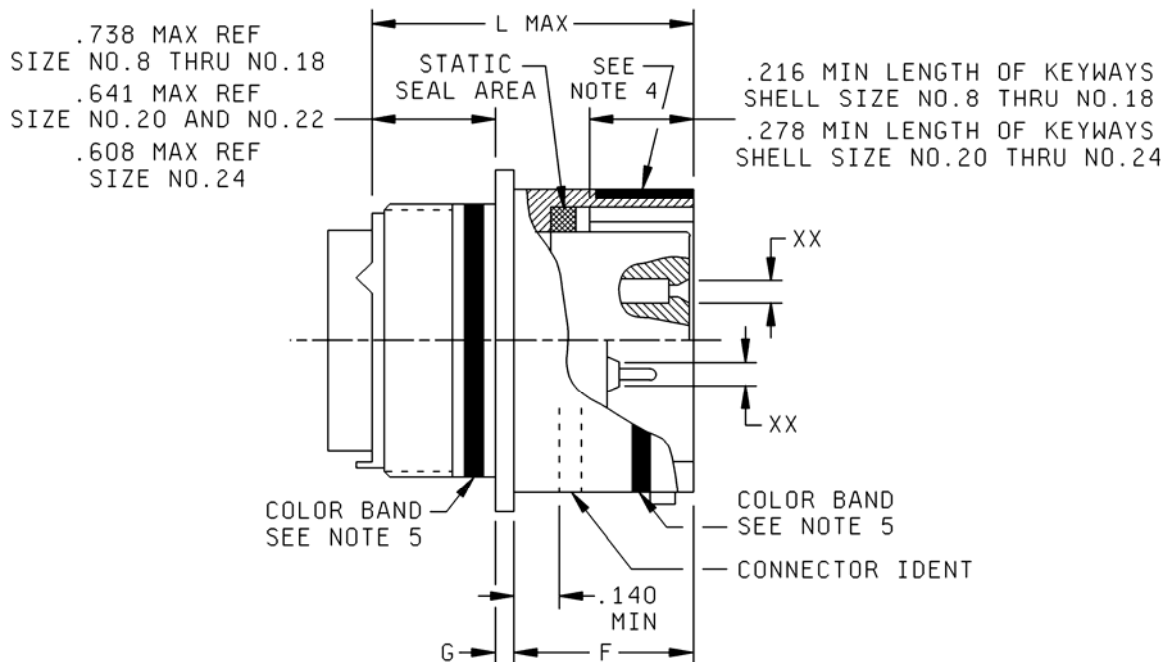

NOTE: For "XX", see note 6 and table I for contact cavities requiring reduced dimensions.

FIGURE 1. Receptacle, classes A, L and W, dimensions and configurations.

MS3471E

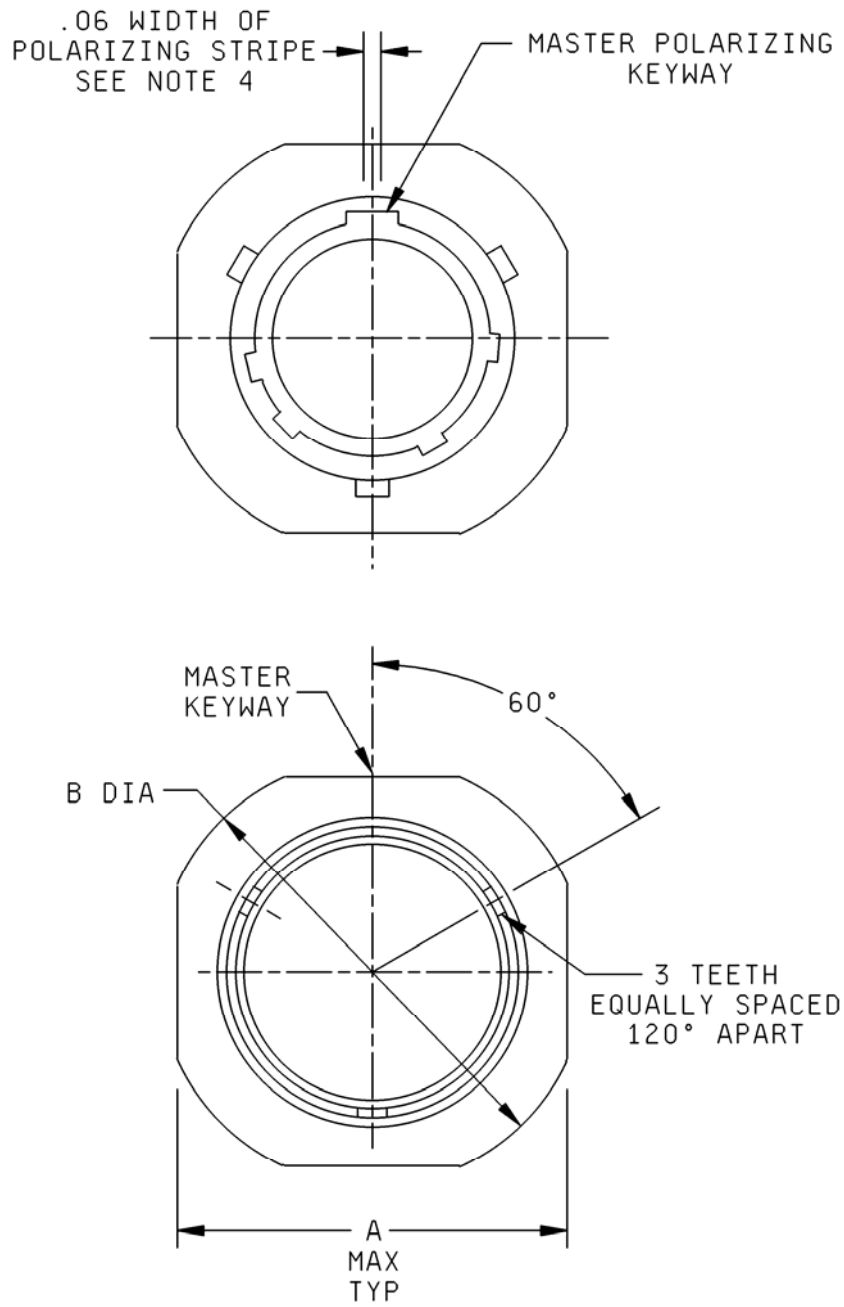
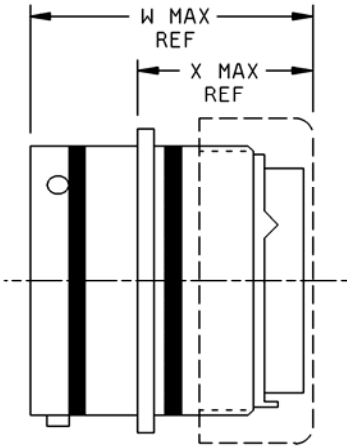
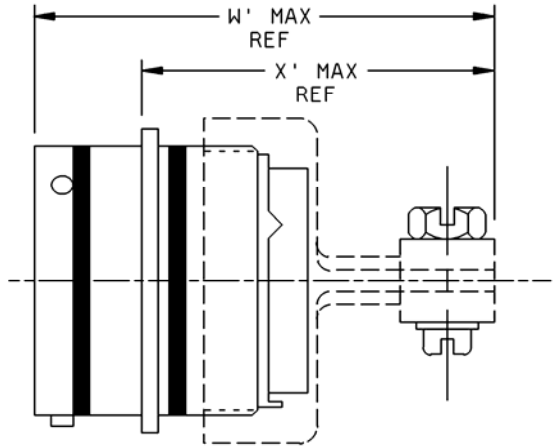

FIGURE 1. Receptacle, classes A, L and W, dimensions and configurations - Continued.

MS3471E



ASSEMBLED TO STRAIGHT BACKSHELL
LESS STRAIN RELIEF
SEE NOTE 7



ASSEMBLED TO STRAIGHT BACKSHELL
WITH STRAIN RELIEF
SEE NOTE 7

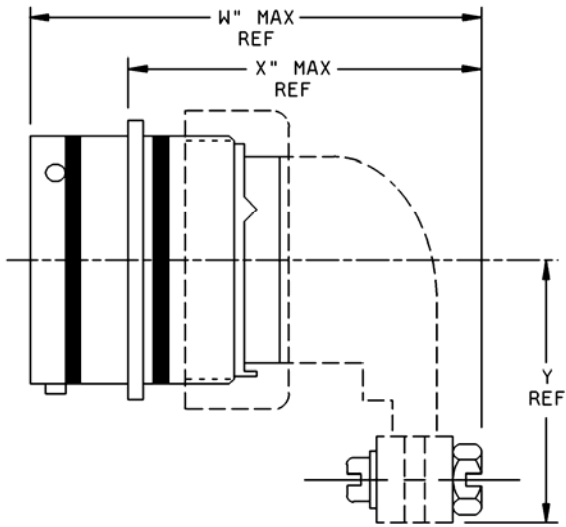

ASSEMBLED TO 90° BACKSHELL
WITH STRAIN RELIEF
SEE NOTE 7

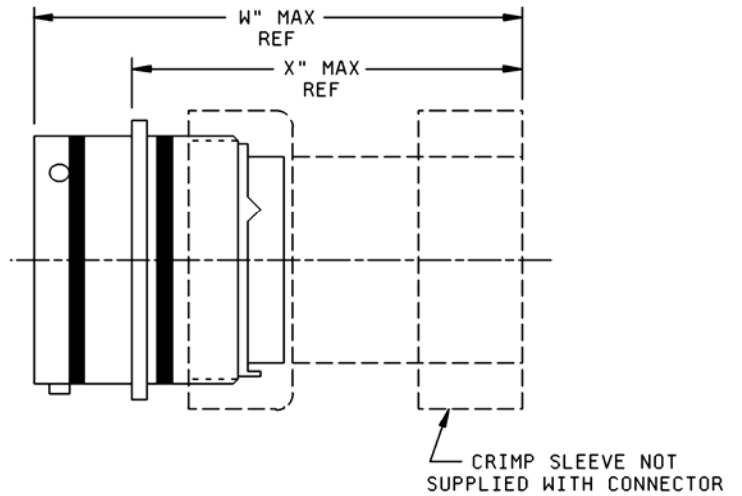

ASSEMBLED TO RFI BACKSHELL
SEE NOTE 7

FIGURE 1. Receptacle, classes A, L and W, dimensions and configurations - Continued.

MS3471E

Shell size	A	B	F	G	L	W	W'	W''
8	.828 (21.03)	.958 (24.33) .918 (23.32)	.462 (11.73) .431 (10.95)	.078 (1.98) .046 (1.17)	1.215 (30.86)	1.492 (37.90)	1.842 (46.79)	2.115 (53.72)
10	.954 (24.23)	1.082 (27.48) 1.042 (26.47)						
12	1.047 (26.59)	1.176 (29.87) 1.136 (28.85)						
14	1.141 (28.98)	1.270 (32.26) 1.230 (31.24)					2.077 (52.76)	2.250 (57.15)
16	1.234 (31.34)	1.364 (34.65) 1.324 (33.63)						
18	1.328 (33.73)	1.458 (37.03) 1.418 (36.02)						
20	1.453 (36.91)	1.582 (40.18) 1.542 (39.17)	.587 (14.91) .556 (14.12)	.110 (2.79) .078 (1.98)	1.275 (32.39)	1.552 (39.42)	2.137 (54.28)	2.767 (70.28)
22	1.578 (40.08)	1.708 (43.38) 1.668 (42.37)						2.890 (73.41)
24	1.703 (43.26)	1.832 (46.53) 1.792 (45.52)						.620 (15.75) .589 (14.96)

FIGURE 1. Receptacle, classes A, L and W, dimensions and configurations - Continued.

MS3471E

Shell size	W'''	X	X'	X''	X'''	Y	Pin max weight lbs (grams)	Socket max weight lbs (grams)	
8	2.339 (59.41)	1.061 (26.95)	1.411 (35.84)	1.684 (42.77)	1.920 (48.77)	.880 (22.35)	.0159 (7.22)	.0167 (7.58)	
10									.0227 (10.30)
12							1.819 (46.20)	.950 (24.13)	.0311 (14.12)
14				1.646 (41.81)		1.909 (48.49)	1.010 (25.65)	.0392 (17.80)	.0483 (21.93)
16						2.044 (51.92)	1.070 (27.18)	.0503 (22.84)	.0609 (27.65)
18						2.143 (54.43)	1.130 (28.70)	.0542 (24.60)	.0699 (31.73)
20	2.399 (60.93)	.996 (25.30)	1.581 (40.16)	2.211 (56.16)	1.855 (47.12)	1.190 (30.23)	.0698 (31.69)	.0898 (40.77)	
22						2.334 (59.28)	1.260 (32.00)	.0797 (36.18)	.1090 (49.48)
24			.963 (24.46)	1.548 (39.32)	2.423 (61.54)	1.822 (46.28)	1.320 (33.53)	.1048 (47.58)	.1241 (56.34)

Inches	mm
.060	1.524
.125	3.175
.140	3.556
.216	5.487
.278	7.061
.608	15.443
.641	16.281
.719	18.263
.738	18.745
.830	21.082
.906	23.012

FIGURE 1. Receptacle, classes A, L and W, dimensions and configurations - Continued.

MS3471E

NOTES:

1. Dimensions are in inches. Metric equivalents are given for information only.
2. Unless otherwise specified, tolerances are $\pm .005$ (0.13 mm) for 3 place decimals, and $\pm .01$ (0.3 mm) for 2 place decimals, angular tolerances are $X^\circ, \pm 1^\circ$.
3. True position (TP) tolerances specified are in accordance with ASME Y14.5M.
4. Polarizing stripes, color optional.
5. Color bands: $0.070 \pm .031$ (1.78 ± 0.79 mm) wide, color blue. Band location must be such that it is visible when mounting.
6. Insert arrangements requiring reduced diameters for raised seal barrier on outer row of contact cavities as indicated.
7. Connector assembly must be used with a backshell. Backshells must be procured separately. See SAE-AS85049 for applicable backshells.

FIGURE 1. Receptacle, classes A, L and W, dimensions and configurations - Continued.TABLE I. Contact cavities requiring reduced diameters (XX) for pins and sockets in outer row of contact cavities. 1/

Shell size	Insert arrangement	Contact cavities
8	-33 & -98	A, B, C.
12	-10	C, G.
14	-12	A, B, C, D, E, F, G, H.
14	-18	A, C, E, G, J, L.
14	-19	B, D, F, H, K, M.
16	-26	A, B, C, D, E, F, G, H, J, K, L, M, N, P, R.
18	-32	A, B, C, D, E, F, G, H, J, K, L, M, N, P, R, S, T.
22	-41	A, B, C, D, E, F, G, H, J, K, L, M, N, P, R, S, T, U, V, W, X, Y.

1/ The reduced diameter "XX" refers to the diameters of the raised seal barriers (pin barrier rings) or lead-in chamfers (socket entry holes) to ensure proper sealing of pin and socket after mating. See MIL-DTL-26482, connector intermateability control dimensions (series 1 and series 2) figure for reduced diameter "XX" for contact size 20 only.

REQUIREMENTS:

Dimensions and configuration: See figure 1 and table I.

Connector mating: This connector mates with MS3475 and MS3476.

For insert arrangement: See MIL-STD-1669.

Connector identification marking shall be in accordance with MIL-DTL-26482. Example: MS3471L----, minimum height does not apply to shell sizes 8, 10 and 12.

Class E is cancelled and superseded by class L.

Intermateability and rear accessory interchangeability dimensions shall be in accordance with MIL-DTL-26482.

This MS sheet supersedes MS3471(Navy), MIL-C-83723/7B and MIL-C-83723/8B.

MS3471E

Part or Identifying Number (PIN) example:

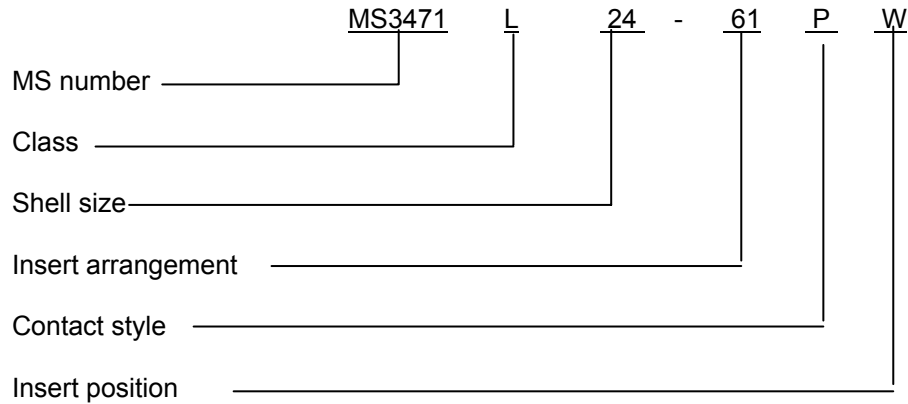

Changes from previous issue. Marginal notations are not used in this revision to identify changes with respect to the previous issue due to the extent of the changes.

Referenced documents. In addition to MIL-DTL-26482, this document references the following:

MS3475
 MS3476
 MIL-STD-1669
 ASME Y14.5M
 SAE-AS85049

CONCLUDING MATERIAL

Custodians:
 Army - CR
 Navy - AS
 Air Force - 11
 DLA - CC

Preparing activity:
 DLA - CC
 (Project 5935-4656-013)

Review activities:
 Army - AR, AV
 Navy - EC, SH
 Air Force - 99

NOTE: The activities listed above were interested in this document as of the date of this document. Since organizations and responsibilities can change, you should verify the currency of the information above using the ASSIST Online database at <http://assist.daps.dla.mil>.