

FED SUP CLASS
6615

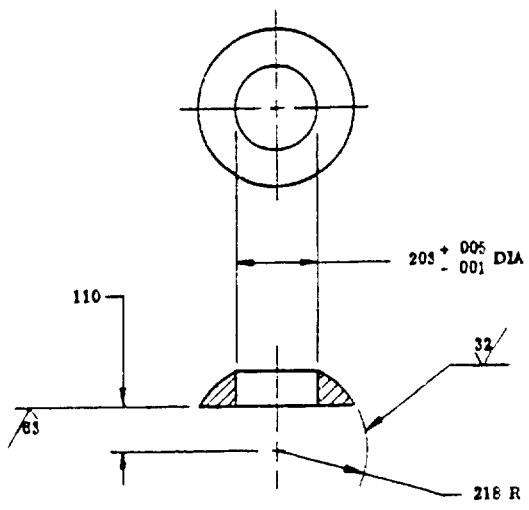

NOTES

- 1 MATERIAL CORROSION RESISTANT STEEL, CL 410, COND A IN ACCORDANCE WITH QQ-S-763
- 2 SURFACE ROUGHNESS SURFACE CONDITION FINISH DESIGNATIONS IN ACCORDANCE WITH USAS1 B46 1 - 1962
- 3 HEAT TREAT HARDEN TO ROCKWELL C28 TO C38 (125,000 TO 150,000 PBT., IN ACCORDANCE WITH MIL-B-6875
- 4 REMOVE ALL BURRS AND BREAK ALL SHARP EDGES
- 5 DIMENSIONS IN INCHES UNLESS OTHERWISE SPECIFIED, TOLERANCES DECIMALS ± .001, DIMENSIONING AND TOLERANCING IN ACCORDANCE WITH USAS1 Y14 5 - 1966

FOR DESIGN FEATURE PURPOSES THIS STANDARD TAKES PRECEDENCE OVER PROCUREMENT DOCUMENTS REFERENCED HEREIN
REFERENCED DOCUMENTS SHALL BE OF THE ISSUE IN EFFECT ON DATE OF INVITATIONS FOR BID

Project No. 6615-N006

P A NAVY - AS Other Cust	TITLE WASHER, SPECIAL	MILITARY STANDARD
		MS3351(AS)
PROCUREMENT SPECIFICATION MIL-N-81604	SUPERSEDES	SHEET 1 OF 1

APPROVED 10 Jan 69 REVISED

This standard has been approved by the NAVAL AIR SYSTEMS COMMAND
 Department of the NAVY and is mandatory for use by
 that activity. All other military activities are required
 to employ this standard where suitable.