

INCH-POUND

MS3216D
 25 October 2011
 SUPERSEDING
 MS3216C
 23 February 2004

DETAIL SPECIFICATION SHEET

RING, RETAINING, EXTERNAL, PRONG-LOCK
 (REDUCED SECTION TYPE)

This specification sheet is approved for use by all Departments and Agencies of the Department of Defense.

The requirements for acquiring the product described herein shall consist of this specification sheet and procurement specification MIL-R-21248.

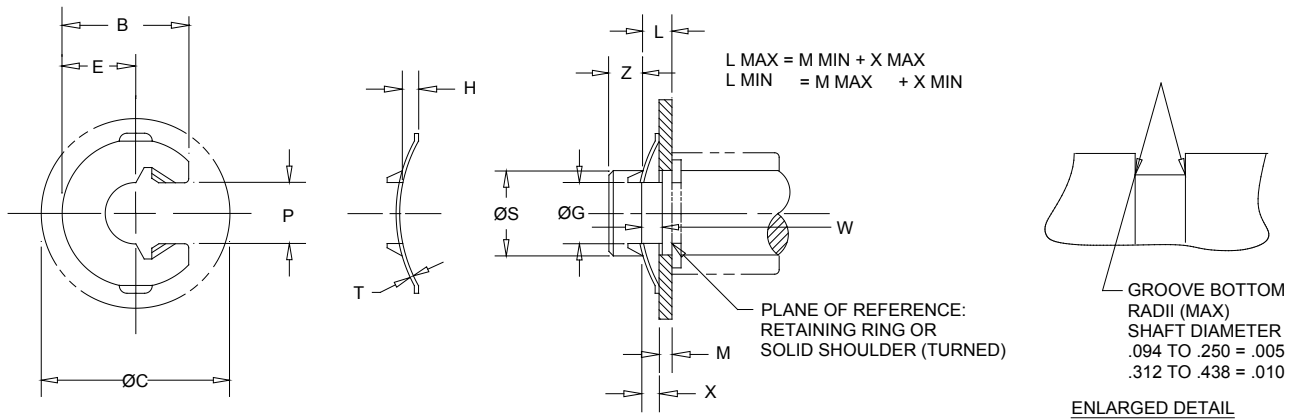

Table I. Dimensions.

ØShaft (Ref)		ØP Free Gap		B Overall Height		E	H Bow Height	T ^{1/} Thickness		ØG		W Width	ØC Clearance
Inch	mm	Basic	Tol	Basic	Tol	(Ref)	±.010	Basic	Tol	Basic	Tol	+ .005 - .000	Inch
.094	2.4	.063		.307		.166	.050	.010		.061	± .001 .003 FIM ^{2/}	.035	.370
.125	3.2	.086	± .004	.307		.166	.050	.010	± .001	.082	± .0015 .003 FIM ^{2/}	.035	.370
.156	4.0	.108		.330	± .010	.184	.055	.010		.104	± .002 .004 FIM ^{2/}	.040	.410
.188	4.8	.130		.390		.213	.060	.015		.124		.045	.480
.250	6.3	.172		.500		.280	.070	.015		.165		.055	.620
.312	7.9	.234	± .005	.620		.360	.095	.015	± .002	.228	± .003 .005 FIM ^{2/}	.080	.790
.375	9.5	.280		.740	.427	.130	.020			.270		.095	.940
.438	11.1	.340	± .010	.820	± .020	.475	.130	.020		.327		.105	1.050

^{1/} T = Thickness "T" applies to unplated rings. For corrosion resistant steel and plated rings, +.002 should be added to the maximum tolerance, i.e., ±.002 should be +.004/- .002.

^{2/} FIM = (Full Indicator Movement) is the maximum allowable deviation of concentricity between the groove and the shaft.

MS3216D

Table I. Dimensions. (continued)

Ø Shaft (Ref)		X Distance from outer groove wall to face of retained part		Resilient take-up of tolerances of L and M	Approx Average Resistance (lb) within X max and X min				Approx force to flatten	
					Rings of				Rings of	
					Carbon steel and CRES	Beryl- lium copper	Carbon steel and CRES	Beryl- lium copper	Carbon steel and CRES	Beryl- lium copper
Inch	mm	Min	Max	X max X min	As installed		After plating		lb	lb
.094	2.4	.030	.038	.008	9	6.5	3.5	2.5	30	20
.125	3.2	.030	.040	.010	8	5	3	2.5	30	20
.156	4.0	.035	.045	.010	8	5	4	2.5	30	20
.188	4.8	.039	.049	.010	20	13	5.5	4.5	60	40
.250	6.3	.045	.060	.015	15	10.5	7	5	60	40
.312	7.9	.070	.085	.015	6	5	4	3.5	60	40
.375	9.5	.080	.105	.025	19	14	7	5.5	80	50
.438	11.1	.095	.120	.025	12	9	6	5	60	40

REQUIREMENTS:

- Classification: Retaining rings furnished under this standard shall be Type II, Class 4 of the procurement specification, MIL-R-21248.
- Material:
 - Carbon spring steel, grade 1060 thru 1095 (UNS G10600 thru G10950) in accordance with ASTM A684/A684M as applicable or A568/A568M.
 - Corrosion resistant steel in accordance with AMS 5520 (UNS S15700).
 - Beryllium copper alloy number 170 (UNS C17000) or alloy number 172 (UNS C17200) in accordance with ASTM B194.
- Hardness:

TABLE II. Hardness

Ø Shaft (Ref)	Carbon Steel	Corrosion Resistant Steel	Beryllium Copper
.094 to .250 incl	83.5-86HR15N	82.5-86HR15N	77-82HR15N
.094 to .312 incl			
.094 to .438 incl	65-69.5HR3ON	63-69.5HR3ON	
.312 to .438 incl			
.375 and .438			

- Protective finish or surface treatment:
 - Carbon steel - shall be as specified (see table III):
 - Cadmium plate in accordance with SAE-AMS-QQ-P-416, Type II, Class 3 or ASTM B696, Type II, Class 5 or zinc-nickel plate in accordance with AMS 2417, Type 2.
 - Zinc coat in accordance with ASTM B633, type II, class Fe/Zn5, or ASTM B695, Type II, Class 5.
 - Phosphate coat in accordance with MIL-DTL-16232, Type Z, Class 2.
 - Corrosion resistant steel - shall be cleaned, descaled and passivated in accordance with SAE-AMS2700.

MS3216D

5. Part number: The basic MS part number is followed by a dash number taken from table III.

Example: MS3216-1025 is the part number for a carbon steel cadmium plate, external, prong-lock, retaining ring for use on a .250 diameter shaft

TABLE III. Dash numbers for MS3216

ØS Shaft (Ref)	<u>1/</u> Carbon Steel Cadmium Plate or Zinc-Nickel	<u>1/</u> Carbon Steel Zinc-Coat	<u>1/</u> Carbon Steel Phosphate Coat	Steel Corrosion Resistant	<u>1/</u> Beryllium Copper
	Dash No.	Dash No.	Dash No.	Dash No.	Dash No.
.094	-1009	-2009	-3009	-4009	-5009
.125	-1012	-2012	-3012	-4012	-5012
.156	-1015	-2015	-3015	-4015	-5015
.188	-1018	-2018	-3018	-4018	-5018
.250	-1025	-2025	-3025	-4025	-5025
.312	-1031	-2031	-3031	-4031	-5031
.375	-1037	-2037	-3037	-4037	-5037
.438	-1043	-2043	-3043	-4043	-5043

1/ Substitute corrosion resistant steel when used in food processing machinery, or in fuel or lubrication systems, or when used at temperatures over 450 °F (233 °C).

6. Unless otherwise specified, all dimensions are in inches.

7. In the event of a conflict between the text of this document and the references cited herein, the text of this document shall take precedence.

8. Unless otherwise specified, issues of referenced documents are those in effect at the time of solicitation.

MS3216D

9. Recommended design limitations and usage.

(a) Intended use - To provide large shoulders for positioning and maintaining machine parts. They are applied radially and are locked positively in their groove by means of two prongs extending from the inner circumference to the open end. They withstand high thrust loads and relative rotation between the retained parts. Their bowed construction provides resilient end-play take-up in axial direction. They may be assembled and disassembled with a screwdriver or with the prong-lock applicator. Sizes .125 to .312 are available rod-stacked for high speed application. The use of the following formulas are based on the fact that the ring material will not fail in compression. Limitation on use - the following formulas are not to be used for brittle materials such as cast iron, etc.

Warning - Rings shall not be over expanded during installation since this will lead to ring failure.

(b) Allowable thrust load capacity of the rings. Abutting components to have sharp corners =

$$P = \frac{\pi STX}{1.75 F} \quad \text{Where:}$$

P = Allowable thrust load (pounds).
 S = Shaft diameter (inches).
 T = Ring thickness (inches).
 X = Ultimate shear strength of the ring material (psi). ^{1/}
 F = Factor of safety.

A safety factor, F = 3, is recommended, since the ring after flattening under load is subjected not only to pure shear stresses but also to bending stresses.

(c) Allowable load capacity of groove wall =

$$P = \frac{\pi SdY}{2F} \quad \text{Where:}$$

P = Allowable compression load (pounds)
 S = Shaft diameter (inches)
 d = Groove depth (inches)
 Y = Yield strength in compression of the groove material (psi)
 F = Factor of safety

To insure a safe working load a safety factor, F = 3, is recommended, since the working stress in the groove section is raised considerably by the notch effect of the deep groove.

(d) Minimum distance between outer groove wall and end of shaft =

$$Z = 2d \quad \text{Where:}$$

Z = Minimum distance between outer groove wall and end of shaft (inches)
 d = Groove depth (inches)

(e) Differential rotation =

Differential rotation of ring and adjacent part creates no element of risk, because the ring is locked in its groove by two locking prongs.

^{1/} X = 130,000 psi ultimate shear strength for rings of carbon steel or corrosion resistant steel.
 X = 110,000 psi ultimate shear strength for rings of beryllium copper.

MS3216D

10. Changes from previous issue. The margins of this specification are marked with vertical lines to indicate where changes from the previous issue were made. This was done as a convenience only and the Government assumes no liability whatsoever for any inaccuracies in these notations. Bidders and contractors are cautioned to evaluate the requirements of this document based on the entire content irrespective of the marginal notations and relationship to the last previous issue.

MILITARY INTEREST

Custodians:

Army - AR

Navy - OS

Air Force – 99

Preparing activity:

DLA - IS

(Project 5325-2011-003)

Review Activities:

Army – AT, CR4, MI

Navy – MC

NOTE: The activities listed above were interested in this document as of the date of this document. Since organizations and responsibilities can change, you should verify the currency of the information above using the ASSIST Online database at <https://assist.daps.dla.mil>