

USER ACTIVITIES:  
ARMY-AT, ME  
NAVY-MC

REVIEWER ACTIVITIES:  
ARMY-MI  
AIR FORCE - 82  
DLA-IS

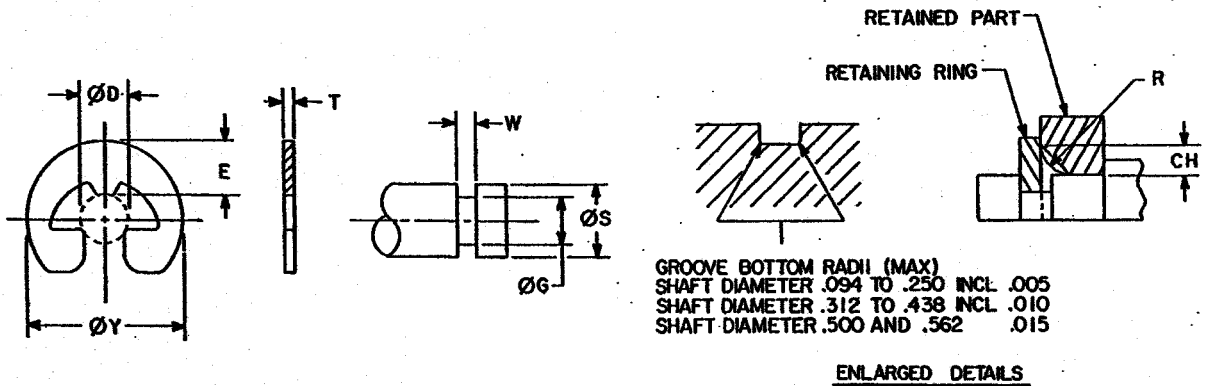

TABLE I. DIMENSIONS

ØS SHAFT (REF)		ØD FREE		E LARGE SECTION HEIGHT	T <sup>1/</sup> THICKNESS		ØG		W WIDTH		R <sup>2/</sup> / CH <sup>2/</sup> OF RETAINED PART (REF)		ØY FREE OUTSIDE	
RECOMMENDED GROOVE (REF)														
INCH	MM	BASIC	TOL	(REF)	BASIC	TOL	BASIC	TOL	BASIC	TOL	MAX	MAX	(REF)	
.094	2.4	.072	+.001	.067	.015		.074	+.002	.020	+.002	.045	.033	.206	
.125	3.2	.093	-.003	.089	.015		.095	-.000	.020	-.000	.045	.033	.270	
.156	4.0	.113	+.002 -.003	.111	.025		.116	.0015 FIN <sup>2/</sup>	.030		.065	.050	.335	
.188	4.8	.143	±.003	.116	.025	+.002	.147		.030		.065	.050	.375	
.219	5.6	.182		.132	.025		.188	+.002	.030	.065	.050	.446		
.250	6.3	.204		.156	.025		.210	.002 FIN <sup>2/</sup>	.030		.065	.050	.516	
.312	7.9	.242		.173	.025		.250	+.003	.030	+.003	.070	.055	.588	
.375	9.5	.292	±.004	.184	.035		.303	-.003	.040	-.000	.070	.055	.660	
.438	11.1	.332		.207	.035	.343	FIN <sup>2/</sup>	.040	.070	.055	.746			
.500	12.7	.385		.212	.042		.396	+.003	.047		.080	.060	.810	
.562	14.3	.430		.220	.042		.437	.004 FIN <sup>2/</sup>	.047		.080	.060	.870	

- 1/ T = THICKNESS "T" APPLIES TO UNPLATED RINGS. FOR CORROSION RESISTANT STEEL AND PLATED RINGS, +.002 SHOULD BE ADDED TO THE MAXIMUM TOLERANCE, I.E., +.002 SHOULD BE +.004/-.002.
- 2/ FIN = (FULL INDICATOR MOVEMENT) IS THE MAXIMUM ALLOWABLE DEVIATION OF CONCENTRICITY BETWEEN THE GROOVE AND THE SHAFT.
- 3/ R AND CH = RADII OR CHAMFERS ALLOWABLE ON PARTS TO BE RETAINED BY THE RINGS. THRUST LOADS OF RINGS, RETAINING PARTS WITH CORNER RADII OR CHAMFERS (SEE NOTE "(g)" ON PAGE 4).

(B) DENOTES CHANGE

DISTRIBUTION STATEMENT A. Approved for public release; distribution is unlimited.  
This military standard is approved for use by all Departments and Agencies of the Department of Defense.  
Selection for all new engineering and design applications and for repetitive use shall be made from this document when applicable.

P.A. NAVY-OS Other Cust ARMY-AR AIR FORCE-99	INTERNATIONAL INTEREST	TITLE RING, RETAINING, EXTERNAL, "E", REINFORCED (REDUCED SECTION TYPE)	MILITARY STANDARD MS3215
PROCUREMENT SPECIFICATION MIL-R-21248	SUPERSEDES:	PAGE 1	OF 4

APPROVED 20 NOV 68  
REVISED  
A 28 APR 89 B 26 APR 90

FED. SUP CLASS  
5365**REQUIREMENTS:**

1. **CLASSIFICATION:** RETAINING RINGS FURNISHED UNDER THIS STANDARD SHALL BE TYPE I, CLASS 9 OF THE PROCUREMENT SPECIFICATION.
2. **MATERIAL:**
  - (a) CARBON SPRING STEEL, GRADE 1060 THRU 1095 (UNS G10600 THRU G10950) IN ACCORDANCE WITH ASTM A568 OR ASTM A682.
  - (b) CORROSION RESISTANT STEEL IN ACCORDANCE WITH AMS 5520 (UNS S15700).
  - (c) BERYLLIUM COPPER ALLOY NUMBER 170 (UNS C17000) OR ALLOY NUMBER 172 (UNS C17200) IN ACCORDANCE WITH ASTM B194.
3. **HARDNESS:**

TABLE II. HARDNESS

Ø SHAFT (REF)	CARBON STEEL	CORROSION RESISTANT STEEL	BERYLLIUM COPPER
.094 AND .125	84.5-87HR15N	82.5-86HR15N	77-82HR15N
.156 TO .312 INCL	66.5-71HR30N	63-69.5HR30N	54-62HR30N
.375 TO .562 INCL	47-52HRC	44-51HRC	34-43HRC

4. **PROTECTIVE FINISH OR SURFACE TREATMENT:**

- (a) CARBON STEEL - SHALL BE AS SPECIFIED (SEE TABLE III):
    - (1) CADMIUM PLATE IN ACCORDANCE WITH QQ-P-416, TYPE II, CLASS 3 OR ASTM B696, TYPE II, CLASS 5.
    - (2) ZINC COAT IN ACCORDANCE WITH ASTM B633, TYPE II, CLASS Fe/Zn5, OR ASTM B695, TYPE II.
    - (3) PHOSPHATE COAT IN ACCORDANCE WITH DOD-P-16232, TYPE Z, CLASS 2.
  - (b) CORROSION RESISTANT STEEL - SHALL BE CLEANED, DESCALED AND PASSIVATED IN ACCORDANCE WITH QQ-P-35.
5. **PART NUMBER:** THE BASIC MS PART NUMBER IS FOLLOWED BY A DASH NUMBER TAKEN FROM TABLE III.
- EXAMPLE: MS3215-1025 IS THE PART NUMBER FOR A CARBON STEEL CADMIUM PLATE, EXTERNAL, "E" REINFORCED, RETAINING RING FOR USE ON A .250 DIAMETER SHAFT

**NOTES:**

1. UNLESS OTHERWISE SPECIFIED, ALL DIMENSIONS ARE IN INCHES.
2. IN THE EVENT OF A CONFLICT BETWEEN THE TEXT OF THIS STANDARD AND THE REFERENCES CITED HEREIN, THE TEXT OF THIS STANDARD SHALL TAKE PRECEDENCE.
3. REFERENCED GOVERNMENT (OR NON-GOVERNMENT) DOCUMENTS OF THE ISSUE LISTED IN THAT ISSUE OF THE DEPARTMENT OF DEFENSE INDEX OF SPECIFICATIONS AND STANDARDS (DODISS) SPECIFIED IN THE SOLICITATION FORM A PART OF THIS STANDARD TO THE EXTENT SPECIFIED HEREIN.

TABLE III. DASH NUMBERS FOR MS3215

ØS SHAFT (REF)	CARBON STEEL <sup>1/</sup> CADMIUM PLATE	CARBON STEEL <sup>1/</sup> ZINC COAT	CARBON STEEL <sup>1/</sup> PHOSPHATE COAT	STEEL CORROSION RESISTANT	BERYLLIUM <sup>1/</sup> COPPER
	DASH NO.	DASH NO.	DASH NO.	DASH NO.	DASH NO.
.094	-1009	-2009	-3009	-4009	-5009
.125	-1012	-2012	-3012	-4012	-5012
.156	-1015	-2015	-3015	-4015	-5015
.188	-1018	-2018	-3018	-4018	-5018
.219	-1021	-2021	-3021	-4021	-5021
.250	-1025	-2025	-3025	-4025	-5025
.312	-1031	-2031	-3031	-4031	-5031
.375	-1037	-2037	-3037	-4037	-5037
.438	-1043	-2043	-3043	-4043	-5043
.500	-1050	-2050	-3050	-4050	-5050
.562	-1056	-2056	-3056	-4056	-5056

<sup>1/</sup> SUBSTITUTE CORROSION RESISTANT STEEL WHEN USED IN FOOD PROCESSING MACHINERY, OR IN FUEL OR LUBRICATION SYSTEMS, OR WHEN USED AT TEMPERATURES OVER 450°F (233°C).

USER ACTIVITIES:  
ARMY-AT, ME  
NAVY-MCREVIEWER ACTIVITIES:  
ARMY-MI  
AIR FORCE -82  
DLA-IS

This military standard is approved for use by all Departments and Agencies of the Department of Defense. Selection for all new engineering and design applications and for repetitive use shall be made from this document when applicable.

APPROVED 20 NOV 68 REVISED (B) FOR CHANGES SEE PAGE 1

P.A. NAVY-OS Other Cust ARMY-AR AIR FORCE-99	INTERNATIONAL INTEREST	TITLE	MILITARY STANDARD
		RING, RETAINING, EXTERNAL, "E", REINFORCED (REDUCED SECTION TYPE)	MS3215
PROCUREMENT SPECIFICATION MIL-R-21248	SUPERSEDES:	PAGE	2 OF 4

RECOMMENDED DESIGN LIMITATIONS AND USAGE

(a) INTENDED USE - TO PROVIDE UNUSUALLY LARGE SHOULDERS FOR POSITIONING AND MAINTAINING MACHINE COMPONENTS ON SHAFTS. THEY ARE APPLIED RADIALLY AND WITHSTAND STRONG PUSH-OUT FORCES RESULTING FROM HEAVY VIBRATIONS AND SHOCK LOADS, HIGH ROTATIONAL SPEEDS OR RELATIVE ROTATION BETWEEN THE RETAINED PARTS. THEY ARE OF FURTHER ADVANTAGE WHERE AXIAL ASSEMBLY OF A RETAINING RING IS NOT POSSIBLE AND WHERE FAST ASSEMBLY FOR MASS PRODUCTION LINES IS ESSENTIAL. THE USE OF THE FOLLOWING FORMULAS IS BASED ON THE FACT THAT THE RING MATERIAL WILL NOT FAIL IN COMPRESSION.  
LIMITATION ON USE - THE FOLLOWING FORMULAS ARE NOT TO BE USED FOR BRITTLE MATERIALS SUCH AS CAST IRON, ETC.

WARNING - RINGS SHALL NOT BE OVER EXPANDED DURING INSTALLATION SINCE THIS WILL LEAD TO RING FAILURE. IF RING HAS PLAY BETWEEN THE GROOVE DIAMETER AND THE INSIDE RING DIAMETER THIS INDICATES THAT THE RING HAS BEEN OVER EXPANDED, (PROVIDING GROOVE HAS BEEN MACHINED TO RECOMMENDED DIMENSIONS).

FOR APPROXIMATE SAFETY RPM LIMITS SEE TABLE IV.

TABLE IV. CALCULATED RPM LIMITS. APPLY REQUIRED SAFETY FACTOR.

Ø SHAFT (INCHES)		.125	.188	.250	.375	.500
CARBON STEEL AND CORROSION RESISTANT STEEL	RPM LIMIT	70,000	50,000	38,000	28,000	20,000
BERYLLIUM COPPER	RPM LIMIT	45,000	32,000	24,000	18,000	13,000

(b) ALLOWABLE THRUST LOAD CAPACITY OF THE RINGS. ABUTTING COMPONENTS TO HAVE SHARP CORNERS =

$$P = \frac{\pi S T X}{3F}$$

WHERE:

- P = ALLOWABLE THRUST LOAD (POUNDS)
- S = SHAFT DIAMETER (INCHES)
- T = RING THICKNESS (INCHES)
- X = ULTIMATE SHEAR STRENGTH OF THE RING MATERIAL (PSI) <sup>1/</sup>
- F = FACTOR OF SAFETY

A SAFETY FACTOR, F = 3, IS RECOMMENDED, SINCE THE RING UNDER LOAD IS SUBJECTED NOT ONLY TO PURE SHEAR STRESSES BUT ALSO TO BENDING STRESSES.

(c) ALLOWABLE LOAD CAPACITY OF GROOVE WALL =

$$P = \frac{\pi G d Y}{3F}$$

WHERE:

- P = ALLOWABLE COMPRESSION LOAD (POUNDS)
- G = GROOVE DIAMETER (INCHES)
- d = GROOVE DEPTH (INCHES)
- Y = YIELD STRENGTH IN COMPRESSION OF THE GROOVE MATERIAL (PSI)
- F = FACTOR OF SAFETY

TO INSURE A SAFE WORKING LOAD A SAFETY FACTOR, F = 2, IS RECOMMENDED.

(d) MINIMUM DISTANCE BETWEEN OUTER GROOVE WALL AND END OF SHAFT =

$$z = 2d$$

WHERE:

- z = MINIMUM DISTANCE BETWEEN OUTER GROOVE WALL AND END OF SHAFT (INCHES)
- d = GROOVE DEPTH (INCHES)

<sup>1/</sup> X = 100,000 PSI ULTIMATE SHEAR STRENGTH FOR RINGS .015 THICK OF CARBON STEEL OR CORROSION RESISTANT STEEL.  
X = 120,000 PSI ULTIMATE SHEAR STRENGTH FOR RINGS .025 THICK OF CARBON STEEL OR CORROSION RESISTANT STEEL.  
X = 150,000 PSI ULTIMATE SHEAR STRENGTH FOR RINGS OVER .025 THICK OF CARBON STEEL OR CORROSION RESISTANT STEEL.  
X = 110,000 PSI ULTIMATE SHEAR STRENGTH FOR RINGS OF ALL THICKNESSES OF BERYLLIUM COPPER.

USER ACTIVITIES:  
ARMY-AT, ME  
NAVY-MC

REVIEWER ACTIVITIES:  
ARMY-MI  
AIR FORCE-82  
DLA-IS

This military standard is approved for use by all Departments and Agencies of the Department of Defense. Selection for all new engineering and design applications and for repetitive use shall be made from this document when applicable.

P.A. NAVY-OS Other Cust ARMY-AR AIR FORCE-99	INTERNATIONAL INTEREST	TITLE RING, RETAINING, EXTERNAL, "E", REINFORCED (REDUCED SECTION TYPE)	MILITARY STANDARD MS3215
PROCUREMENT SPECIFICATION MIL-R-21248	SUPERSEDES:	PAGE 3 OF 4	

APPROVED 20 NOV 68 REVISED (B) FOR CHANGES SEE PAGE 1

## (e) DIFFERENTIAL ROTATION =

THE CONDITION UNDER WHICH A RETAINING RING MAY BE USED WHEN ADJACENT PARTS ROTATE RELATIVE TO IT, FALL INTO TWO CATEGORIES:

- (1) WHERE NO THRUST IS EXERTED BY ADJACENT PART; IN THIS CASE, DIFFERENTIAL ROTATION OF RING AND ADJACENT PART CREATES NO ELEMENT OF RISK IN THE APPLICATION OF THE RINGS BECAUSE NO FRICTIONAL TORQUE IS EXERTED BY THE MACHINE PART ON THE RING.
- (2) CONSIDERATION MUST BE GIVEN TO THE MAGNITUDE OF THE THRUST INVOLVED. THE FRICTION MOMENT MAY NOT EXCEED THE BENDING MOMENT, WHICH THE RING CAN TOLERATE WITHOUT RELEASING ITS PRESSURE AGAINST THE BOTTOM OF THE GROOVE, FORMULATED AS FOLLOWS:

$$fPN \leq \frac{STE^2}{50} \quad \text{OR}$$

$$P \leq \frac{STE^2}{f50N}$$

WHERE:

P = ALLOWABLE THRUST LOAD EXERTED BY ADJACENT PART (POUNDS)  
 f = COEFFICIENT OF FRICTION  
 S = WORKING STRESS OF RING UNDER MAXIMUM EXPANSION  
 T = RING THICKNESS (INCHES)  
 E = LISTED "E" DIMENSION OF RING ON PAGE 1  
 N = NEUTRAL RING DIAMETER (INCHES) = FREE DIAMETER PLUS  
 1 1/2 E DIMENSION

IN SUCH CASES WHERE DIFFERENTIAL ROTATION OCCURS, THE CALCULATION SHOULD BE BASED ON THE MAXIMUM POSSIBLE VALUE OF THE COEFFICIENT OF FRICTION.

## (f) IMPACT CAPACITY OF RING OR GROOVE WALL =

$$I_R = \frac{PT}{2} \quad \text{-- FOR THE RING (INCH POUNDS) ABUTTING COMPONENTS TO HAVE SHARP CORNERS}$$

$$I_G = \frac{Pd}{2} \quad \text{-- FOR THE GROOVE (INCH POUNDS)}$$

WHERE:

P = ALLOWABLE THRUST LOAD OF RING OR GROOVE (POUNDS)  
 T = RING THICKNESS (INCHES)  
 I<sub>G</sub> = IMPACT CAPACITY OF GROOVE WALL (INCH POUNDS)  
 d = GROOVE DEPTH (INCHES)  
 I<sub>R</sub> = IMPACT CAPACITY OF RING (INCH POUNDS)

## (g) LOAD CAPACITY WITH THE RETAINED PART RADIUS OR CHAMFERED =

THE ALLOWABLE THRUST LOADS, WHEN COMPUTED FROM THE FORMULAS ON PAGE 3, WILL NOT BE AFFECTED WHEN THE (E) RINGS ARE USED AGAINST PARTS HAVING CORNER RADII OR CHAMFERS UP TO THE LISTED MAXIMUM DIMENSIONS.

USER ACTIVITIES:  
 ARMY-AT, ME  
 NAVY-MC

REVIEWER ACTIVITIES:  
 ARMY-MI  
 AIR FORCE - 82  
 DLA-IS

is military standard is approved for use by all Departments and Agencies of the Department of Defense. Section for all new engineering and design applications and for repetitive use shall be made from this document when applicable.

APPROVED 20 NOV 68  
 REVISED (B) FOR CHANGES SEE PAGE 1

P.A. NAVY-OS Other Cust ARMY-AR AIR FORCE-99	INTERNATIONAL INTEREST	TITLE RING, RETAINING, EXTERNAL, "E", REINFORCED (REDUCED SECTION TYPE)	MILITARY STANDARD
			MS3215
PROCUREMENT SPECIFICATION MIL-R-21248	SUPERSEDES:	PAGE 4 OF 4	